

Le tubazioni vengono fornite per l'utilizzo della macchina nelle sue massime dimensioni.
Se necessario vanno rifilate.

The flexible hoses are supplied to be used in the maximum working sizes.
If necessary they have to be adjusted.

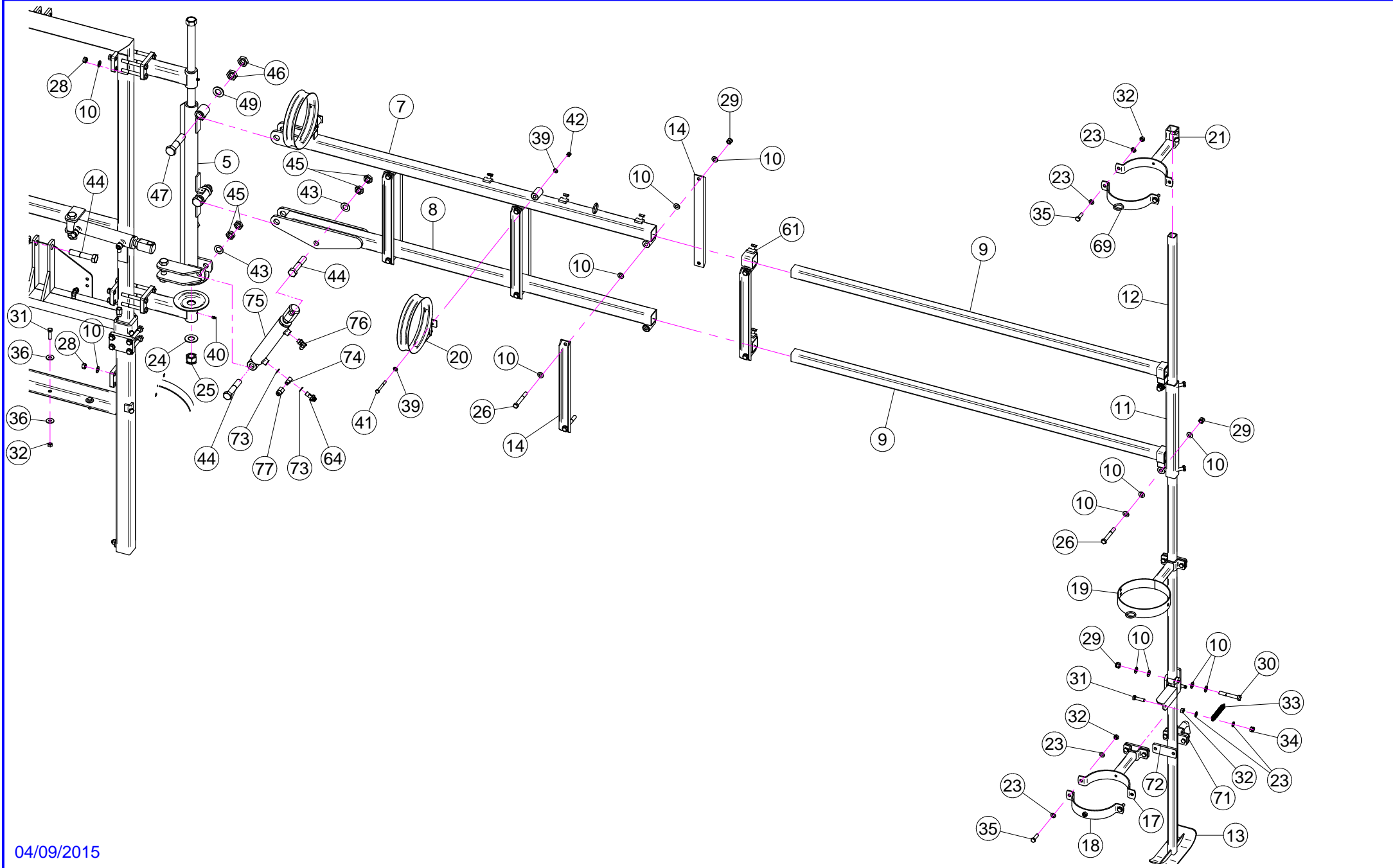

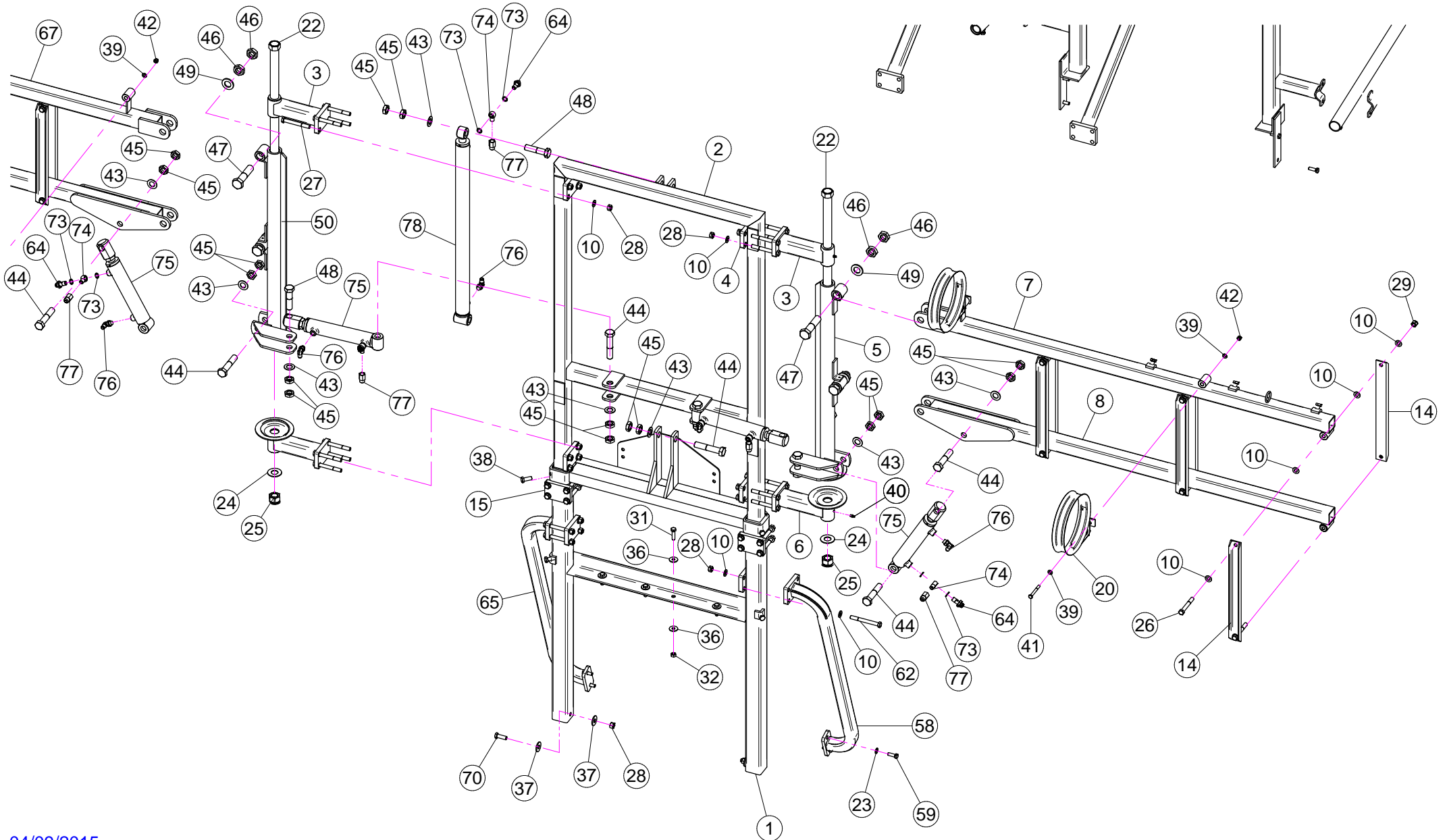

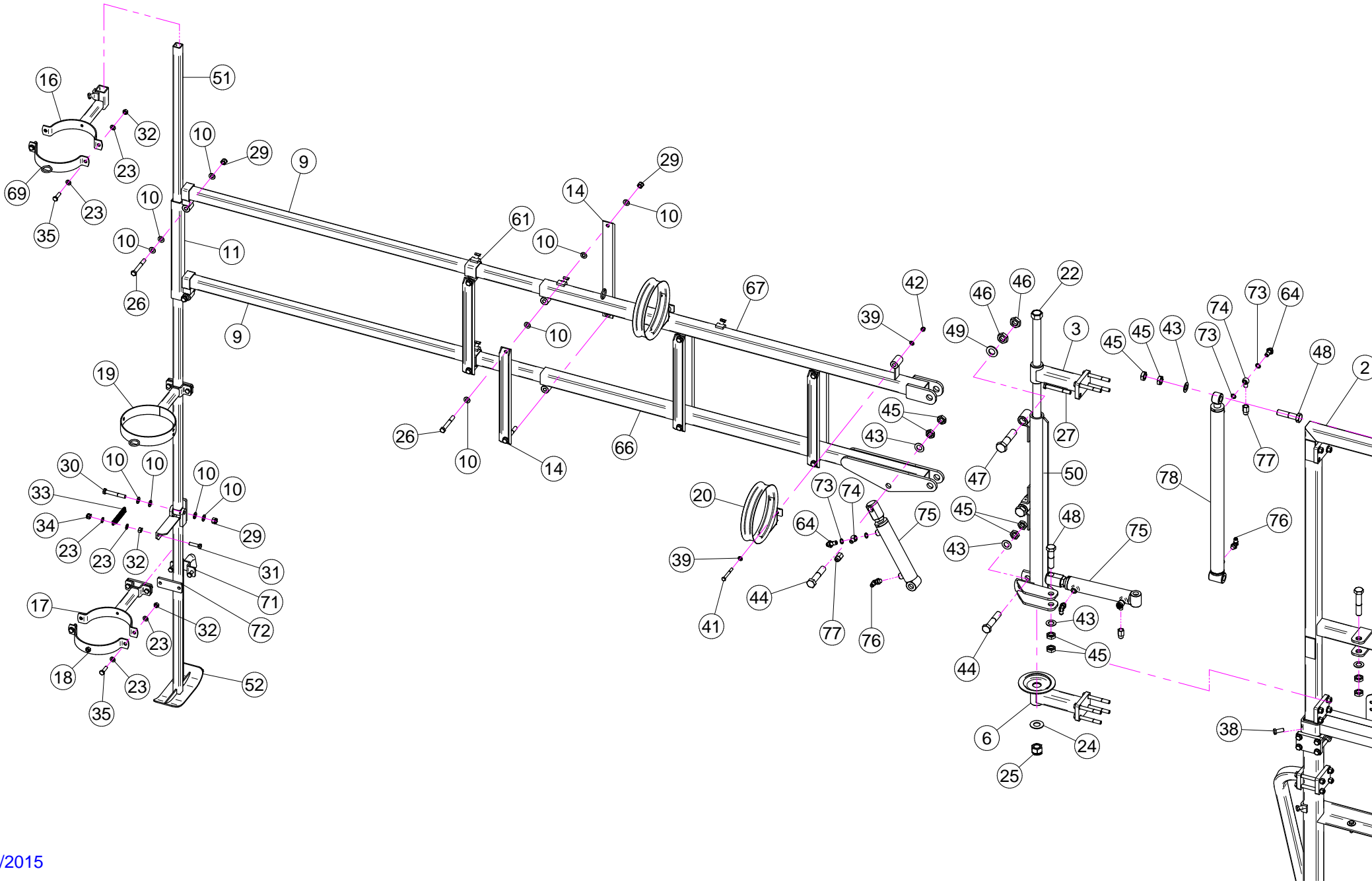

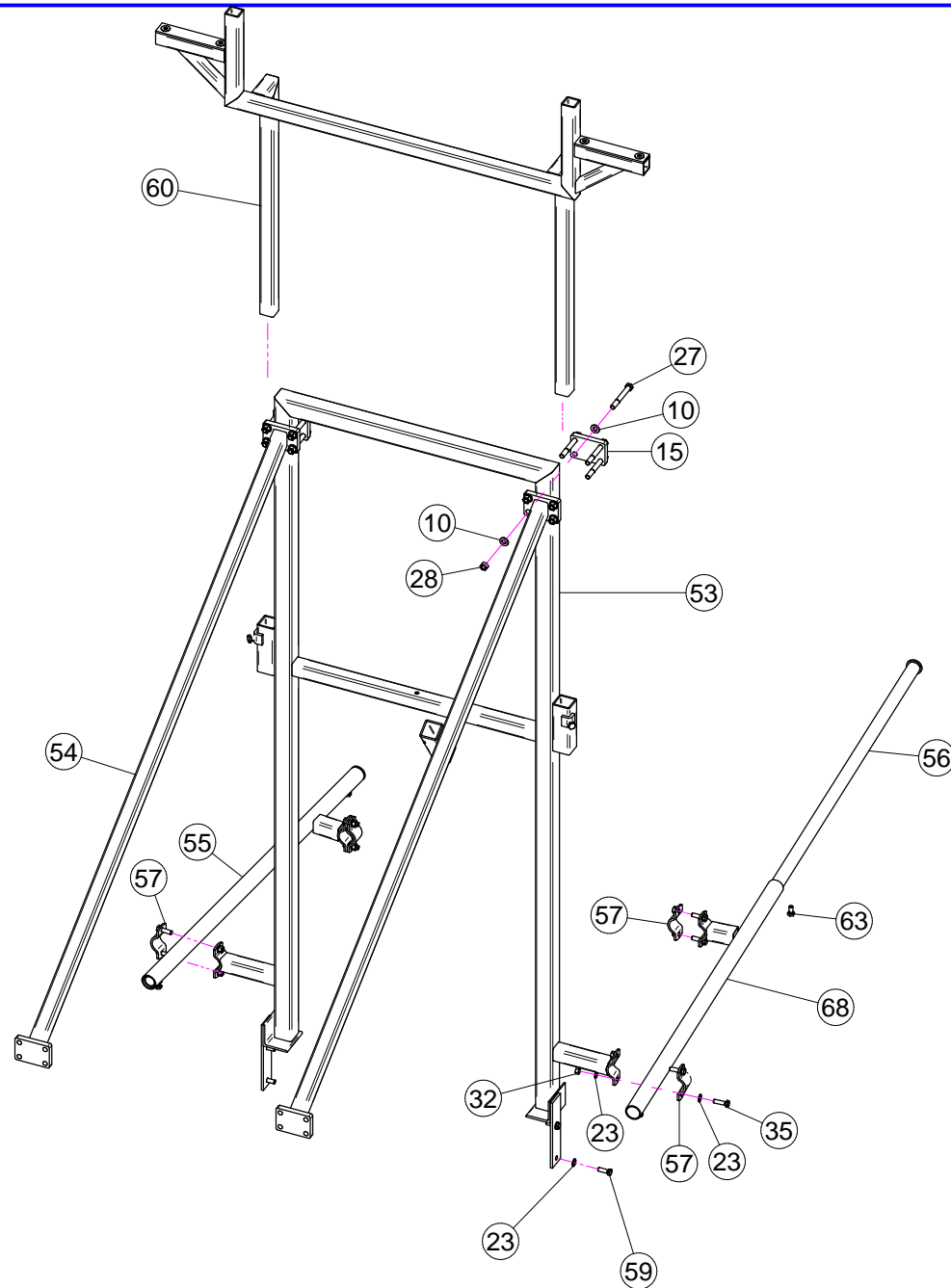

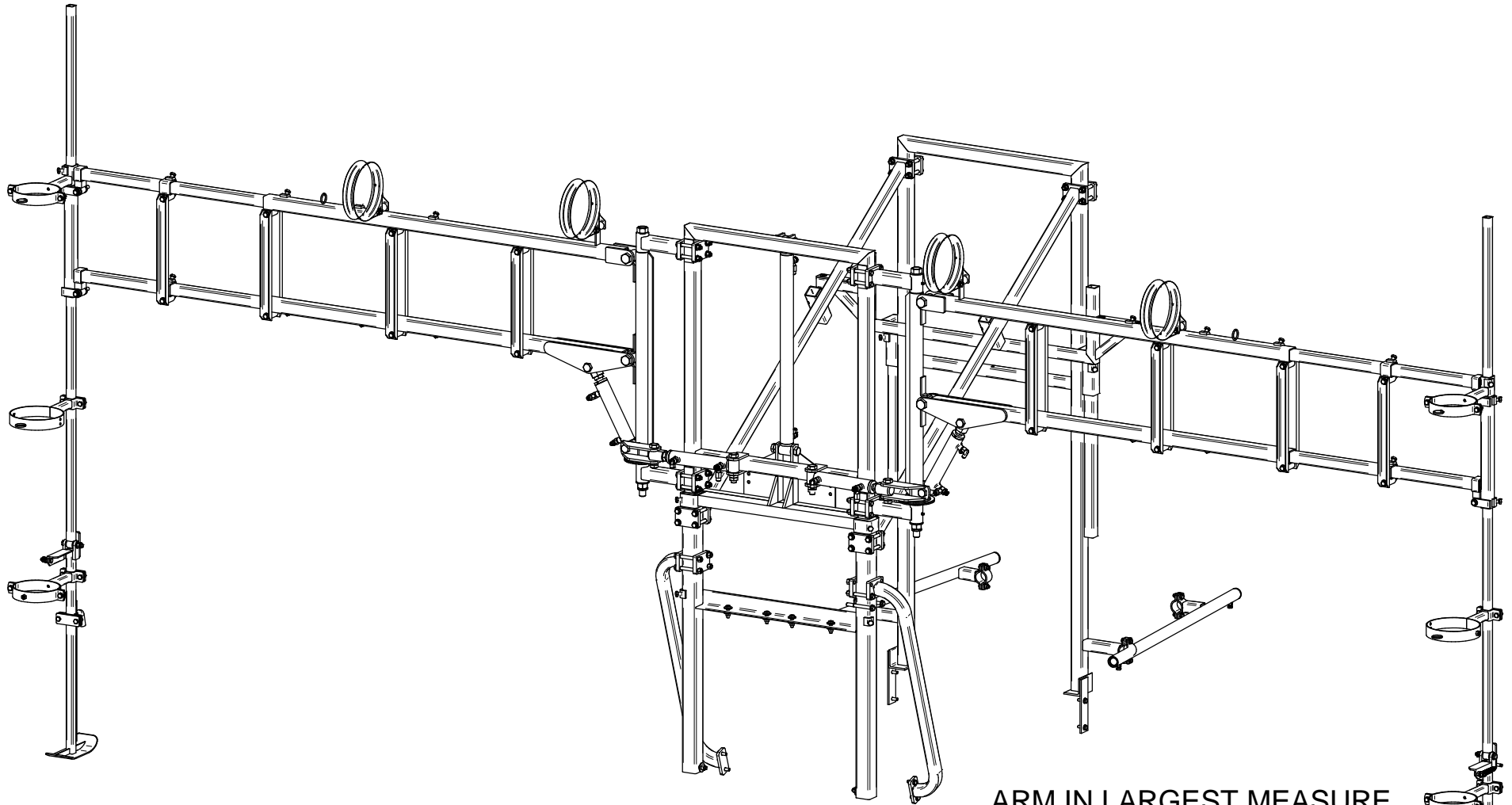

ARM IN SHORTEST MEASURE
FOR 2,30 mt. ROW WIDTH

BRACCIO TUTTO CHIUSO
PER FILARI mt. 2,30

ARM IN LARGEST MEASURE
FOR 3,10 mt. ROW WIDTH

BRACCIO MAXIMA APERTURA
PER FILARI mt. 3,10

N°	Doc. Number	Titolo	Title	Q.tà	Note	N°	Doc. Number	Titolo	Title	Q.tà	Note
1	X21.019.300	TELAIO FISSO	CENTRAL FRAME	1		40	XID.006.001	INGRASSATORE DIRITTO M6	GREASER	2	
2	X21.024.300	TELAIO SCORREVOLE	SLIDING FRAME	1		41	XTE.008.070	VITE TE UNI 5737-65 M8x70-8.8	SCREW TE UNI 5737-65 M8x70-8.8	5	
3	X20.939.000	SOSTEGNO TUBI ROTAZIONE BRACCI SENZA DISCO	KEEPING ARMS PIPES WITHOUT DISK	2		42	XDA.008.0AG	DADO AUTOBLOCCANTE M8	SELF LOCKING NUT M8	5	
4	X20.937.000	PIASTRA FISSAGGIO TUBO ROTAZIONE BRACCI PER TESTATA SCAVALLANTE	PIPE FIXING PLATE ARMS ROTATION FOR WRAP-A-ROUND	4		43	XRP.020.000	RONDELLA PIANA D.20	WASHER D.20	10	
5	X20.958.201	TUBO ROTAZIONE BRACCI DX	RIGHT ARMS ROTATION PIPE	1		44	XTE.020.100	VITE TE UNI 5737-65 M20x100-8.8	SCREW TE UNI 5737-65 M20x100-8.8	7	
6	X20.939.100	SOSTEGNO TUBI ROTAZIONE BRACCI CON DISCO	KEEPING ARMS PIPES WITH DISK	2		45	XD0.20.5589G	DADO BASSO M20	LOWER NUT M20	20	
7	X21.023.100	BRACCIO LATERALE DESTRO SUPERIORE	HIGH RIGHT ARM	1		46	XDO.24.5589G	DADO BASSO M24	LOWER NUT M24	8	
8	X21.022.200	BRACCIO LATERALE DESTRO INFERIORE	RIGHT SIDE ARM	1		47	XTE.024.100	VITE TE UNI 5737-65 M24x100-8.8	SCREW TE UNI 5737-65 M24x100-8.8	4	
9	X21.020.100	BRACCIO SCORREVOLE	SLIDING ARM	4		48	XTE.020.080	VITE TE UNI 5737-65 M20x80-8.8	SCREW TE UNI 5737-65 M20x80-8.8	3	
10	XRP.012.000	RONDELLA PIANA Ø12	WASHER Ø12	141		49	XRP.024.000	RONDELLA PIANA D.24	WASHER D.24	4	
11	X20.884.101	SUPPORTO PALO SCORREVOLE	SLIDING POLE SUPPORT	2		50	X20.959.201	TUBO ROTAZIONE BRACCI SX	LEFT ARM ROTATION PIPE	1	
12	X21.027.000	PALO DI DISCESA SNODATO SUPERIORE DX	RIGHT HIGHER GOING-DOWN PIPE	1		51	X21.027.100	PALO DI DISCESA SNODATO SUPERIORE SX	LEFT HIGHER GOING-DOWN PIPE	1	
13	X20.948.002.Z	PALO DI DISCESA SNODATO INFERIORE DX ZINCATO	RIGHT LOWER GOING-DOWN PIPE ZINCED	1		52	X20.948.102.Z	PALO DI DISCESA SNODATO INFERIORE SX ZINCATO	LEFT LOWER GOING-DOWN PIPE ZINCED	1	
14	X20.879.200	LAMIERA COLLEGAMENTO BRACCI	UNION LEG LAMIN	14		53	X50.226.201	ARCO DI ANCORAGGIO	TIE-ROD	1	
15	X20.940.000	LAMIERA FISSAGGIO TELAIETTO SOSTEGNO BRACCI	BRACKET	6		54	X50.229.000	TIRANTE	TIE ROD	2	
16	X50.209.100	BRACCIO DI DISCESA SOSTEGNO TESTATA DX	RIGHT GOING DOWN ARM	1		55	X50.231.100	TUBO DI ANCORAGGIO	ANCHOR TUBE	1	
17	X50.209.200	BRACCIO DI DISCESA SOSTEGNO TESTATA	GOING-DOWN ARM	2		56	X50.227.000	TAMPONE SCORREVOLE	SLIDING BUFFER	2	
18	X02.986.002	SEMI FASCETTA SEMPLICE D.175 CON DADO M10	HALF CLAMP WITH NUT M10	2		57	XS0.493.000	CAVALLOTTO FISSAGGIO CERCHIO PROTEZIONE	SHAPED PLATE FIXING BUMPER	4	
19	X50.211.000	STAFFA ATTACCO DISTRIBUTORE	BRACKET	2		58	X50.232.300	TIRANTE DI SOSTEGNO DESTRO	RIGHT TIE-ROD	1	
20	X50.040.025	ANELLO DI GUIDA IN ACCIAIO INOX	STAINLESS STEEL GUIDE RING	4		59	XTE.010.030T	VITE TE UNI 5739-65 M10x30-8.8	SCREW TE UNI 5739-65 M10x30-8.8	8	
21	X50.209.000	BRACCIO DI DISCESA SOSTEGNO TESTATA SX	LEFT GOING DOWN ARM	1		60	X50.230.201.Z	CAVALLETTO DI SOSTEGNO ZINCATO	KEEPING FRAME ZINCED	1	
22	X20.910.300	PERNO ROTAZIONE BRACCI	ARM PIN ROTATION	2		61	X20.969.100	COLLEGAMENTO SCORREVOLE PER BRACCI	SLIDING UNION FOR ARMS	4	
23	XRP.010.000	RONDELLA PIANA D.10 6592 ZINC.	WASHER Ø 10	44		62	XTE.012.110	VITE TE UNI 5737-65 M12x110-8.8	SCREW TE UNI 5737-65 M12x110-8.8	16	
24	XRP.024.000	RONDELLA PIANA D.24	WASHER D.24	2		63	XTE.010.020T	VITE TE UNI 5739-65 M10x20-8.8	SCREW TE UNI 5739-65 M10x20-8.8	4	
25	XDA.024.0AG	DADO AUTOBLOCCANTE M24	SELF LOCKING M24	2		64	X20.718.000	REGOLATORE PORTATA IDRAULICA 1/4"	FLOW REGULATOR 1/4"	5	
26	XTE.012.090	VITE TE UNI 5737-65 M12x90-8.8	SCREW TE UNI 5737-65 M12x90-8.8	20		65	X50.232.200	TIRANTE DI SOSTEGNO SINISTRO	LEFT TIE-ROD	1	
27	XTE.012.100	VITE TE UNI 5737-65 M12x100-8.8	SCREW TE UNI 5737-65 M12x100-8.8	24		66	X21.025.200	BRACCIO LATERALE SINISTRO INFERIORE	LOWER LEFT ARM	1	
28	XD0.12.5587G	DADO M12 PG UNI 5587	M12 NUT	42		67	X21.026.100	BRACCIO LATERALE DESTRO SUPERIORE	HIGH RIGHT ARM	1	
29	XDA.012.0AG	DADO AUTOBLOCCANTE M12	SELF LOCKING NUT M12	22		68	X50.231.200	TUBO DI ANCORAGGIO	ANCHOR TUBE	1	
30	XTE.012.080	VITE TE UNI 5737-65 M12x80-8.8	SCREW TE UNI 5737-65 M12x80-8.8	2		69	X02.986.102	SEMI FASCETTA SEMPLICE D.175 CON ANELLO	HALF CLAMP	2	
31	XTE.010.040T	VITE TE UNI 5739-65 M10x40-8.8	SCREW TE UNI 5739-65 M10x40-8.8	6		70	XTE.012.035T	VITE TE UNI 5739-65 M12x35-8.8	SCREW TE UNI 5739-65 M12x35-8.8	2	
32	XD0.10.5587G	DADO M10 6S PG 5587 ZINC.	M10 6S BIG LEAD NUT 5587	22		71	X20.943.100C	APPOGGIO BRACCI A RIPOSO COMPLETO	COMPLETE ARM BLOCK	2	
33	XS0.480.000	MOLLA PER SERRANDA	SPRING	2		72	X50.211.002	PIATTO FISSAGGIO STAFFA ANCORAGGIO	BRACKET	2	
34	XDA.010.0AG	DADO AUTOBLOCCANTE M10	SELF LOCKING NUT M10	2		73	X02.472.000	RONDELLA DI RAME Ø 19x13,5x1,5	COPPER WASHER Ø 19x13,5x1,5	10	
35	XTE.010.035T	VITE TE UNI 5739-65 M10x35-8.8	SCREW TE UNI 5739-65 M10x35-8.8	16		74	X02.471.000	OCCHIO 1/4" PER MARTINETTO	JACK EYE 1/4"	5	
36	XRP.010.030	RONDELLA PIANA F.LARGA D.10X30 ZINC.	10X30mm D. LARGE THREAD FLAT	8		75	X02.838.01C	MARTINETTO LATERALE COMPLETO	HOSE Ø80 L=1850	4	
37	XRP.012.036	RONDELLA PIANA D12 X 36	WASHER D12 X 36	4		76	X02.409.000	RACCORDO CURVO 1/4 " CON DADO	ELBOW WITH RETAINING RING SEAL	5	
38	XTE.012.030T	VITE TE UNI 5739-65 M12x30-8.8	SCREW TE UNI 5739-65 M12x30-8.8	26		77	X20.010.000	RACCORDO DIRITTO PER MARTINETT.USA	ADAPTOR JIC - FEMALE BSP	5	
39	XRP.008.000	RONDELLA PIANA D.8 6592 ZINC.	8 D. FLAT WASHER	10		78	X21.115.000	MARTINETTO COMPLETO D.50 CORSA 640 mm.	COMPLETE JACK D.50 STROKE 640 mm.	1	

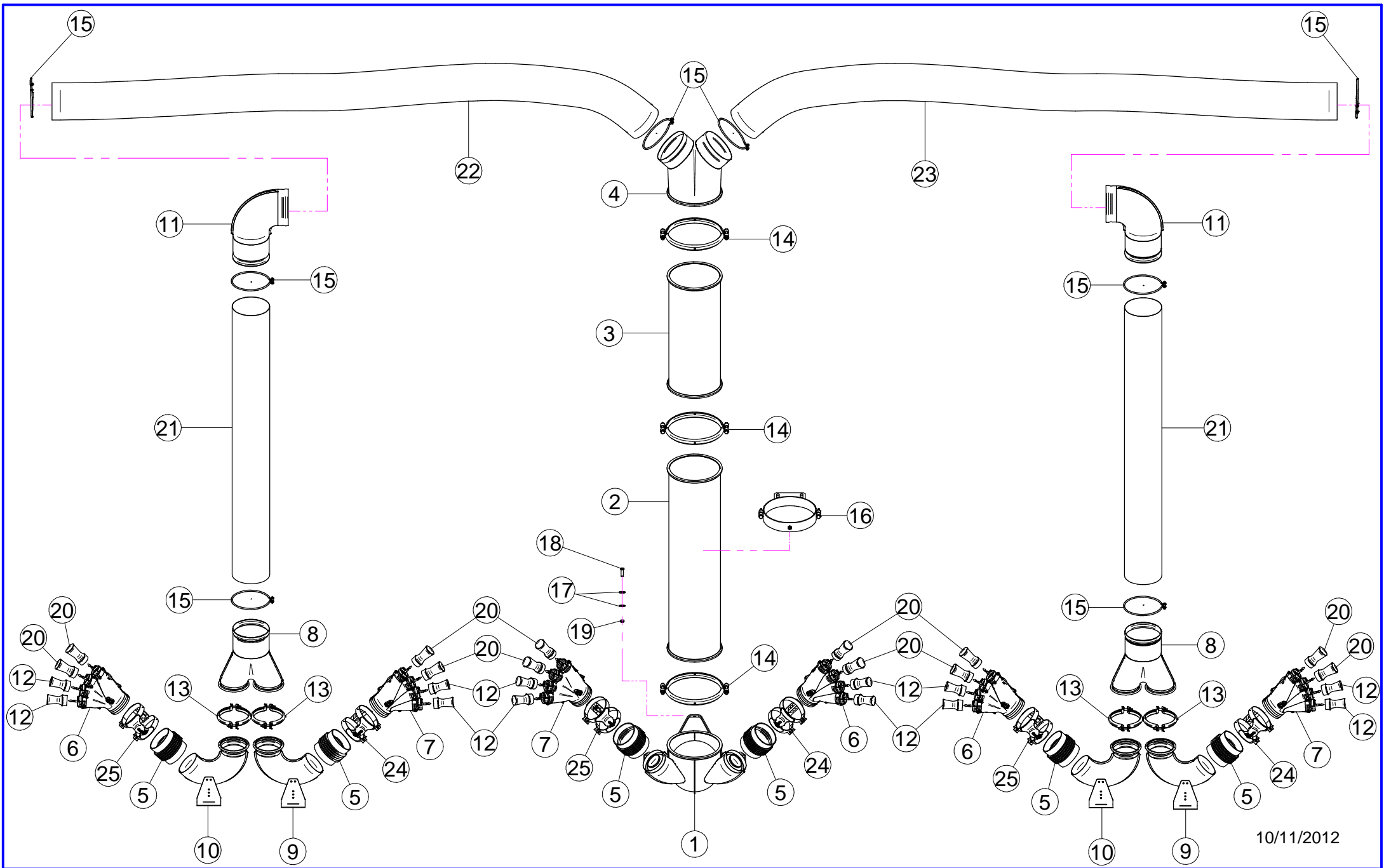

X20.014.000

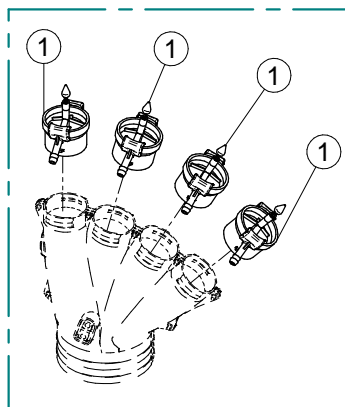

N°	Doc. Number	Titolo	Title	Qtà
1	X05.843.100	CORPO D.250 CON DUE USCITE D.120 SENZA PRESE D'ARIA	BODY D.250 WITH 2 OUTLETS D.120	1
2	X50.075.000	PROLUNGA D.250 x 1000	EXTENSION D.250 x 1000	1
3	X21.100.060	PROLUNGA D.250 x 600	EXTENSION D.250 x 600	1
4	X20.649.000	CORPO D.250 CON 2 USCITE D.175	BODY D.250 WITH 2 OUTLETS D.175	1
5	X02.021.000	MANICOTTO FLESSIBILE D.120	FLEXIBLE SLEEVE	6
6	X20.014.000DX	MANO A 4 USCITE CON TUBETTI	FOUR OUTLETS	3
7	X20.014.000SX	MANO A 4 USCITE CON TUBETTI	FOUR OUTLETS	3
8	X50.210.000	CORPO D.175 CON 2 USCITE D.120	BODY D.175 WITH 2 OUTLETS D.120	2
9	X04.845.300	CURVA A 135° D.120	ELBOW 135° D.120	2
10	X04.845.400	CURVA A 130° D.120	ELBOW 130° D.120	2
11	X20.650.100	CURVA D.175 90° CON 2 PORTAGOMMA D.180	ELBOW D.175 90° WITH 2 RUBBER HOLDER D.180	2
12	X00.006.050	DIFFUSORE 6/50	NOZZLE 6/50	12
13	X04.027.000	COLLARE PER TUBI D. 150	PIPE CLAMP D. 150	4
14	X05.813.010	COLLARE D.275	CLAMP D.275	3
15	XF0.180.000	FASCETTA UNIFILO D.180	CLAMP D.180	8
16	X20.504.000	FASCETTA D.250 FISSAGGIO TESTATE	D.250 CLAMP HEADS FIXING	1
17	XRP.010.030	RONDELLA PIANA D.10 x 30 mm	WASHER D.10 x 30 mm	2
18	XTE.010.035T	VITE TE 10 x 35	SCREW TE 10 x 35	1
19	XD0.10.5587G	DADO M10	NUT M10	1
20	X00.008.050	DIFFUSORE 8/50	NOZZLE 8/50	12
21	X02.388.150	TUBO SPIRALATO D.180 L=1500	HOSE D.180 L=1500	2
22	X02.388.310	TUBO SPIRALATO D.180 L=3100	HOSE D.180 L=3100	1
23	X02.388.310	TUBO SPIRALATO D.180 L=3100	HOSE D.180 L=3100	1
24	X21.080.000	COPPIA FASCETTE Ø 127 DESTRA	RIGHT CLAMP Ø 127	3
25	X21.081.000	COPPIA FASCETTE Ø 127 SINISTRA	LEFT CLAMP Ø 127	3

X20.014.000

N°	Doc.Number	Titolo	Title	Qtà
1	X20.016.01C	RACCORDO ATTACCO RAPIDO PORTA TUBETTO	PIPE WITH OLIVE	4

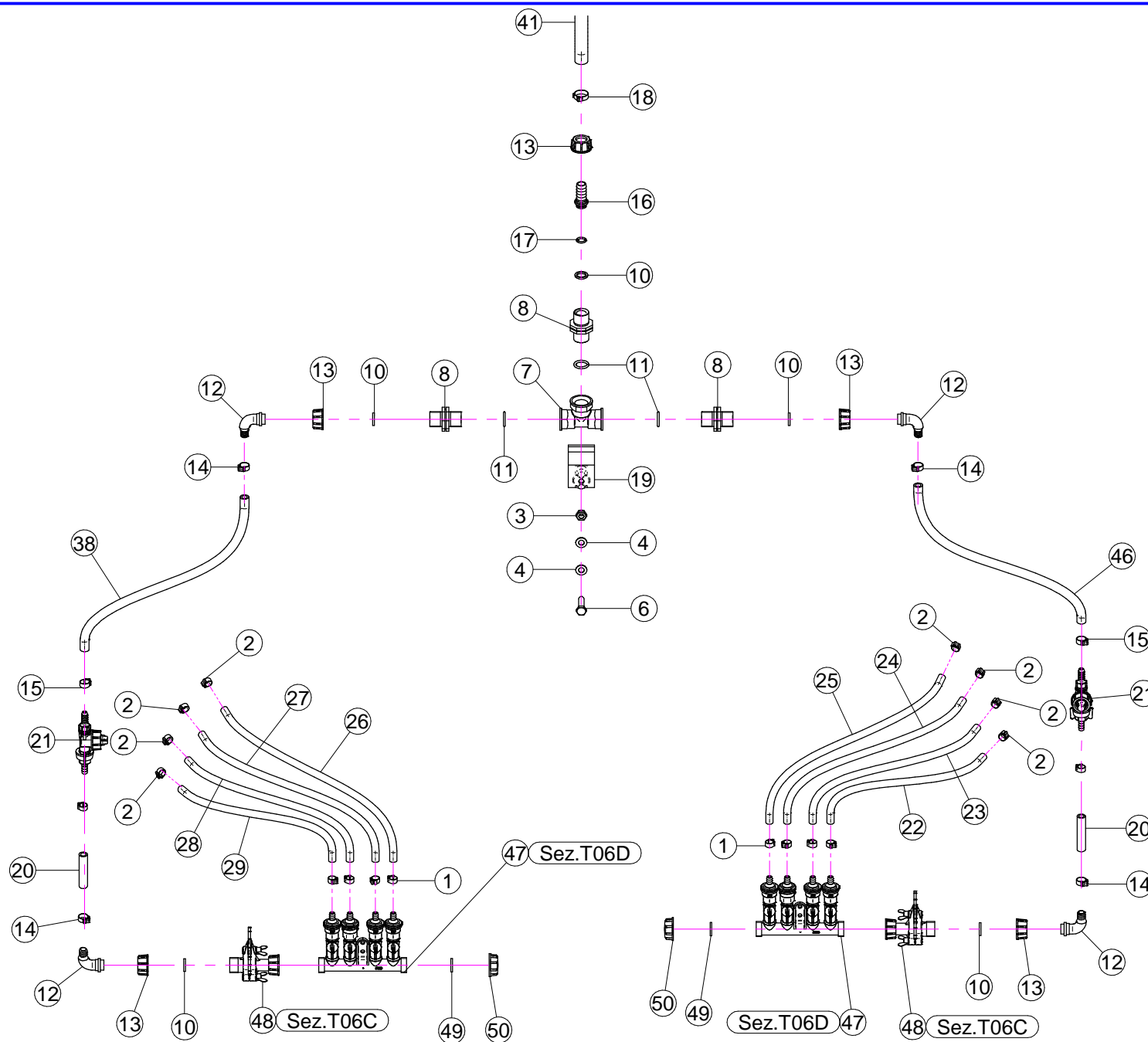

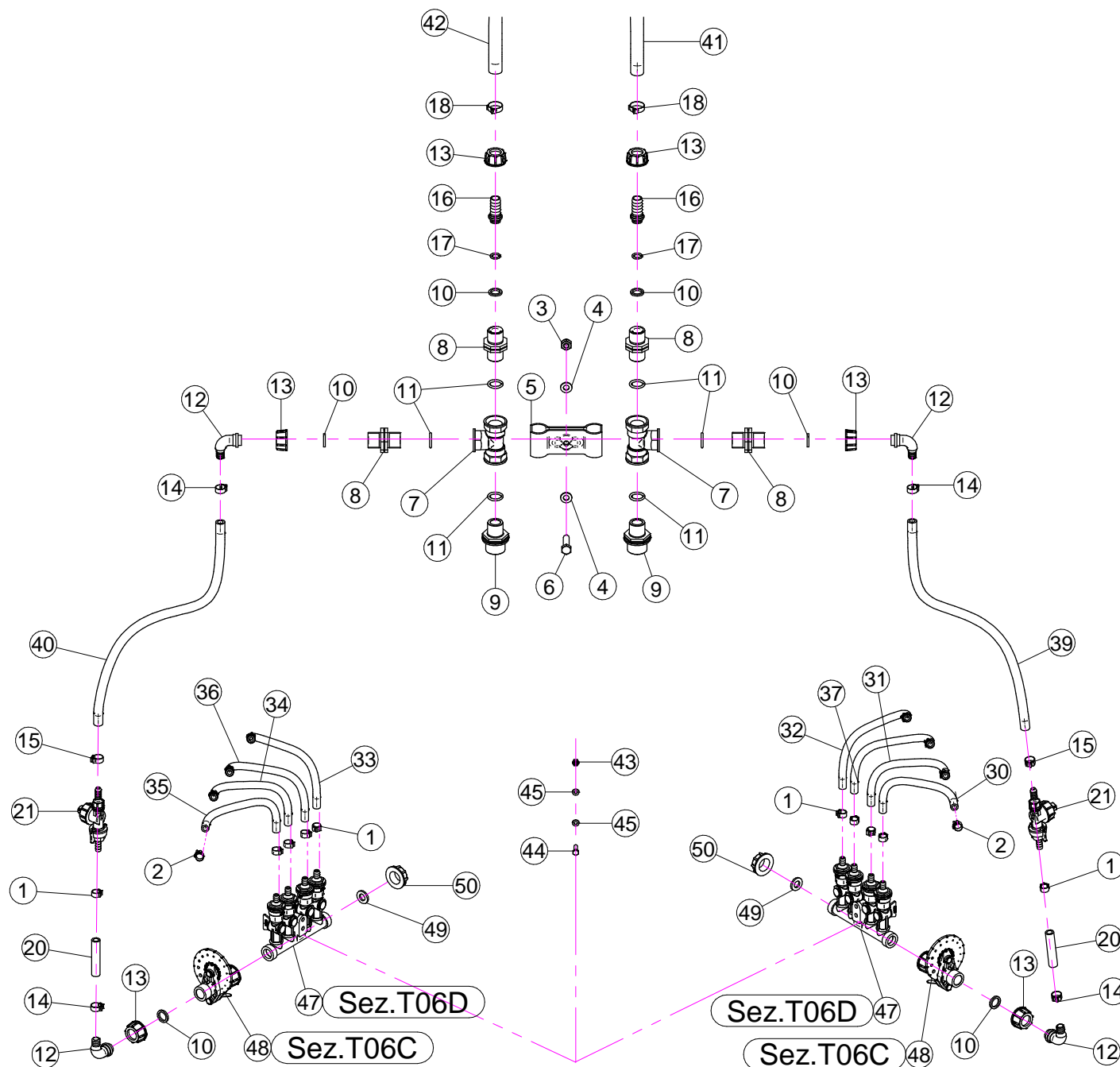

N°	Doc. Number	Titolo	Title	Q.tà	Note	N°	Doc. Number	Titolo	Title	Q.tà	Note
1	XFC.013,5.015	FASCETTA COBRA SLO30710	KOBRA CLAMP	30		26	X02.217.041	TUBO D. 8 x 13 L=410	HOSE D. 8 x 13 L=410	2	
2	XFC.012,5.014	FASCETTA COBRA SLO30705	KOBRA CLAMP	24		27	X02.217.039	TUBO D. 8 x 13 L=390	HOSE D. 8 x 13 L=390	2	
3	XDA.010.0BG	DADO AUTOBLOCCANTE M10	SELF LOCKING NUT M10	3		28	X02.217.033	TUBO D. 8 x 13 L=330	HOSE D. 8 x 13 L=330	2	
4	XRP.010.000	RONDELLA PIANA D.10	WASHER D.10	6		29	X02.217.031	TUBO D. 8 x 13 L=310	HOSE D. 8 x 13 L=310	2	
5	X02.999.000	STAFFA FISSAGGIO RACCORDO A T	T UNION FIXING BRACKET	1		30	X02.217.031	TUBO D. 8 x 13 L=310	HOSE D. 8 x 13 L=310	1	
6	XTE.010.040T	VITE TE M10 x 40	SCREW TE M10 x 40	3		31	X02.217.033	TUBO D. 8 x 13 L=330	HOSE D. 8 x 13 L=330	1	
7	X02.396.000	RACCORDO A T 3/4" - 3/4" - 3/4" F.	UNION 3/4" - 3/4" - 3/4" F.	4		32	X02.217.041	TUBO D. 8 x 13 L=410	HOSE D. 8 x 13 L=410	1	
8	X02.380.000	NIPPLO 3/4"	NIPPLE 3/4"	10		33	X02.217.041	TUBO D. 8 x 13 L=410	HOSE D. 8 x 13 L=410	1	
9	X02.293.000	RIDUZIONE 1" M - 3/4" M	1" M - 3/4" M REDUCER NIPPLE	2		34	X02.217.033	TUBO D. 8 x 13 L=330	HOSE D. 8 x 13 L=330	1	
10	X02.349.000	GUARNIZIONE PIANA D.17X23X3	17X23X3 FLAT GASKET	16		35	X02.217.031	TUBO D. 8 x 13 L=310	HOSE D. 8 x 13 L=310	1	
11	XOR.004.081	OR D.20,22 x 3,53	20,22 x 3,53 O-RING GASKET	12		36	X02.217.039	TUBO D. 8 x 13 L=390	HOSE D. 8 x 13 L=390	1	
12	X00.055.046R	RACCORDO CURVO P.G. D.14	CURVED UNION WITH R.H. D.14	12		37	X02.217.039	TUBO D. 8 x 13 L=390	HOSE D. 8 x 13 L=390	1	
13	X00.055.045	GIRELLO 3/4" GAS	3/4" FLY NUT	16		38	X02.213.090	TUBO D. 10 x 16 L=900	HOSE D. 10 x 16 L=900	2	
14	XFC.016,5.018	FASCETTA COBRA 16,5 - 18	KOBRA CLAMP 16,5 - 18	12		39	X02.213.090	TUBO D. 10 x 16 L=900	HOSE D. 10 x 16 L=900	1	
15	XFC.015,5.017	FASCETTA COBRA SLO30720	KOBRA CLAMP	6		40	X02.213.090	TUBO D. 10 x 16 L=900	HOSE D. 10 x 16 L=900	1	
16	X02.002.000	RACCORDO DIRITTO 3/4" P.G.18	STRAIGHT UNION 3/4" R.H.18	4		41	X02.211.600	TUBO D. 16 x 23 L=6000	HOSE D. 16 x 23 L=6000	1	
17	XOR.000.117	OR D. 13,1x18,34x2,62	13,1x18,34x2;62 O-RING GASKET	4		42	X02.211.600	TUBO D. 16 x 23 L=6000	HOSE D. 16 x 23 L=6000	1	
18	XFC.022,5.024	FASCETTA COBRA 22,5 - 24	KOBRA CLAMP 22,5 - 24	4		43	XD0.06.5588G	DADO M6	NUT M6	12	
19	X02.999.100	STAFFA FISSAGGIO RACCORDO A T	T UNION FIXING BRACKET	2		44	XTE.006.020T	VITE TE M6 x 20	SCREW TE M6 x 20	12	
20	X02.213.007	TUBO D.10 L=70	HOSE D.10 L=70	6		45	XRP.006.000	RONDELLA PIANA D. 6	WASHER D.6	24	
21	X00.226.05C	GETTO ANTIGOCCIA DIRITTO COMPLETO	COMPLETE ANTIDROP	6		46	X02.213.090	TUBO D.10x16 L=900	HOSE D.10x16 L=900	2	
22	X02.217.031	TUBO D. 8 x 13 L=310	HOSE D. 8 x 13 L=310	2		47	X02.008.304C	DISTRIBUTORE LIQUIDI A 4 RUBINETTI	4 TAPS LIQUID MANIFOLD	6	
23	X02.217.033	TUBO D. 8 x 13 L=330	HOSE D. 8 x 13 L=330	2		48	X02.150.000	REGOLATORE A DISCO ROTANTE COMPLETO	ROTATION DISK REGULATION	6	
24	X02.217.039	TUBO D. 8 x 13 L=390	HOSE D. 8 x 13 L=390	2		49	X02.030.010	GUARNIZIONE TAPPO DISTRIBUTORE	GASKET	6	
25	X02.217.041	TUBO D. 8 x 13 L=410	HOSE D. 8 x 13 L=410	2		50	X02.182.000	TAPPO 3/4" FEMMINA	FEMALE 3/4" CAP	6	

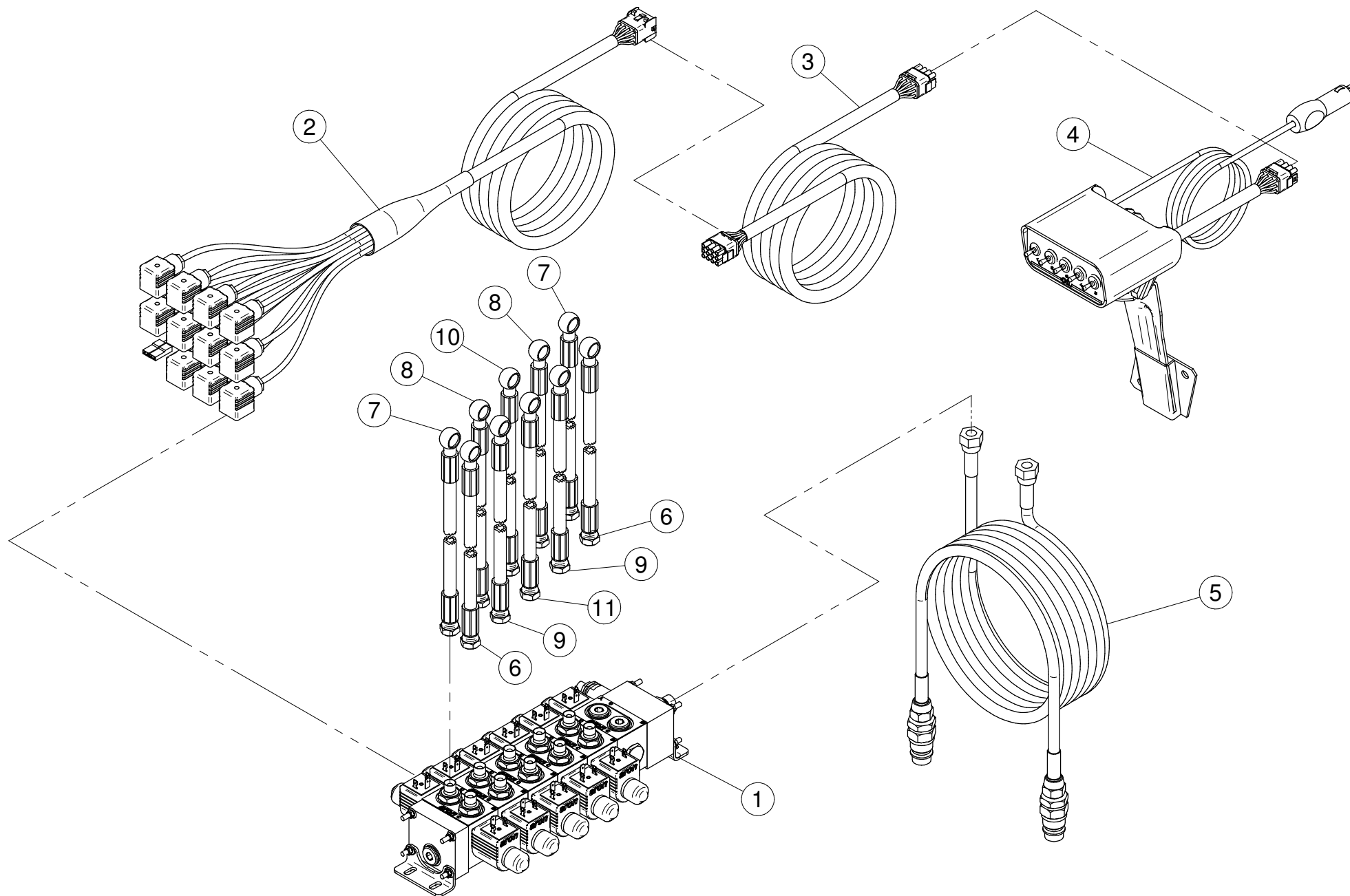

N°	Doc. Number	Titolo	Title	Q.tà	Note
1	X21.057.000	Blocco elettrovalvole componibili	Componible directional valves	1	
2	X21.054.000	Cavo	Cable	1	
3	X21.055.000	Cavo prolunga Mt.3 ML12 M/F	Extension Cable Mt. 3 ML12 M/F	1	
4	X21.030.400	Kit comando elettrico	Kit for control solenoid valve	1	
5	X20.960.600	TUBO OLIO PER MARTINETTO L=6000	OIL PIPE FOR JACK L=6000	2	
6	X20.961.160	Tubo olio per martinetto L=1600	Oil pipe for jack L=1600	2	
7	X20.961.150	Tubo olio per martinetto L=1500	Oil pipe for jack L=1500	2	
8	X20.961.130	Tubo olio per martinetto L=1300	Oil pipe for jack L=1300	2	
9	X20.961.140	Tubo olio per martinetto L=1400	Oil pipe for jack L=1400	2	
10	X20.961.050	Tubo olio per martinetto L=500	Oil pipe for jack L=500	1	
11	X20.961.100	Tubo olio per martinetto L=1000	Oil pipe for jack L=1000	1	

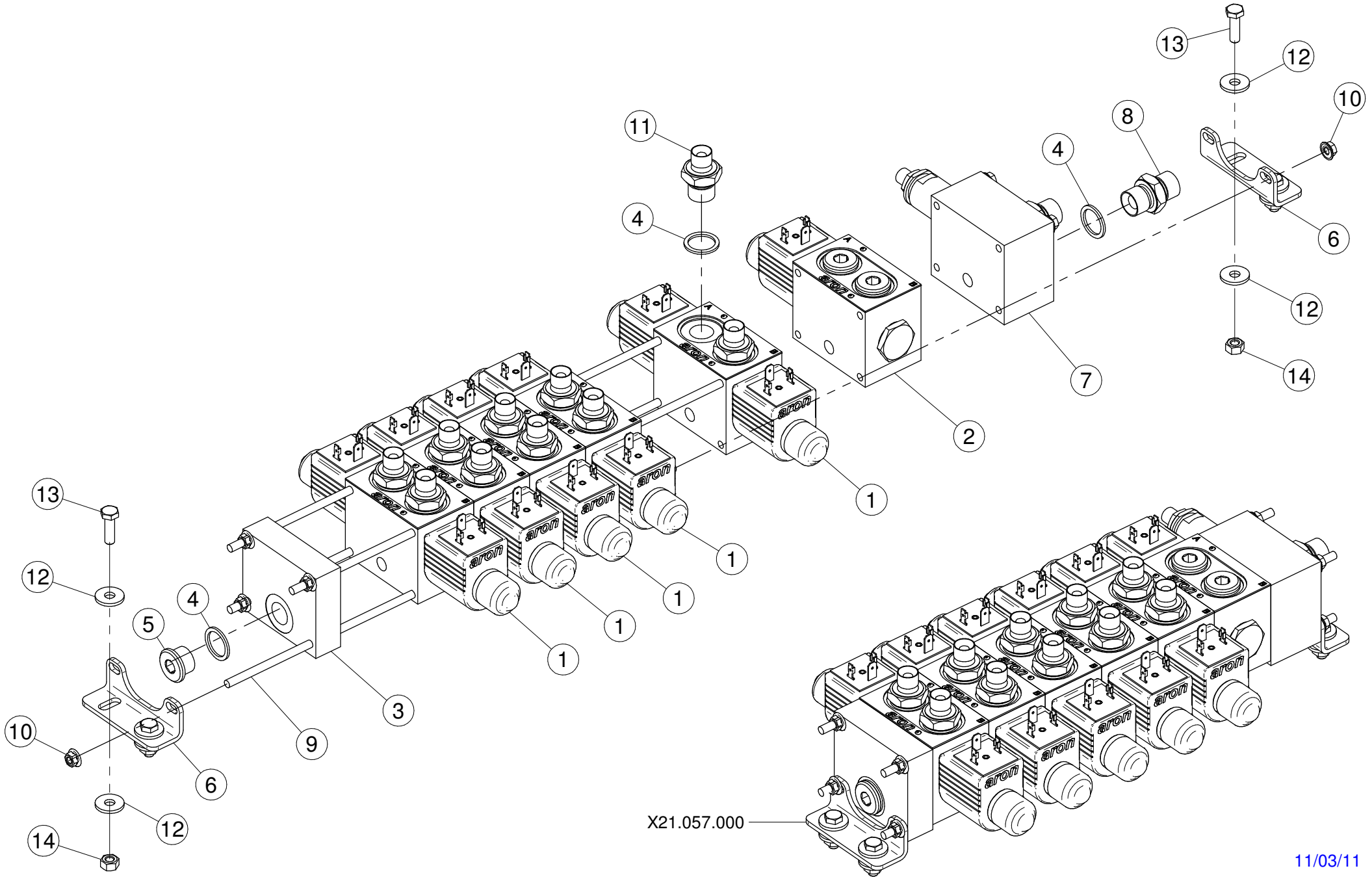

X21.057.000

N°	Doc. Number	Titolo	Title	Q.tà	Note
1	X21.057.010	Elettrovalvola componibile controllo direzione	Directional control stackable valve	5	
2	X21.057.016	Elettrovalvola generale	General valve	1	
3	X21.057.018	Fiancata di chiusura	Outlet module unit	1	
4	X21.057.008	Rondella di rame	Copper washer	13	
5	X21.057.017	Tappo di chiusura G3/8	Cap G3/8	1	
6	X21.057.019	Staffa di fissaggio	Fixing bracket	2	
7	X21.057.024	Valvola meccanica regolazione di pressione	Modular max pressure stackable valve	1	
8	X21.057.021	Raccordo G3/8 - G3/8	Union G3/8 - G3/8	2	
9	X21.057.025	Tirante M5 x 360	Screw M5 x 360	4	
10	X21.057.026	Dado flangiato M5	Hex flange nut M5	8	
11	X21.057.009	Raccordo G1/4 - G3/8	Union G1/4 - G3/8	10	
12	XRP.006.018	Rondella piana larga d.6 x 18	Large washer d. 6 x 18	8	
13	XTE.006.020T	Vite TE M6 x 20	Screw TE M6 x 20	4	
14	XDO.06.5588G	Dado M6	Nut M6	4	

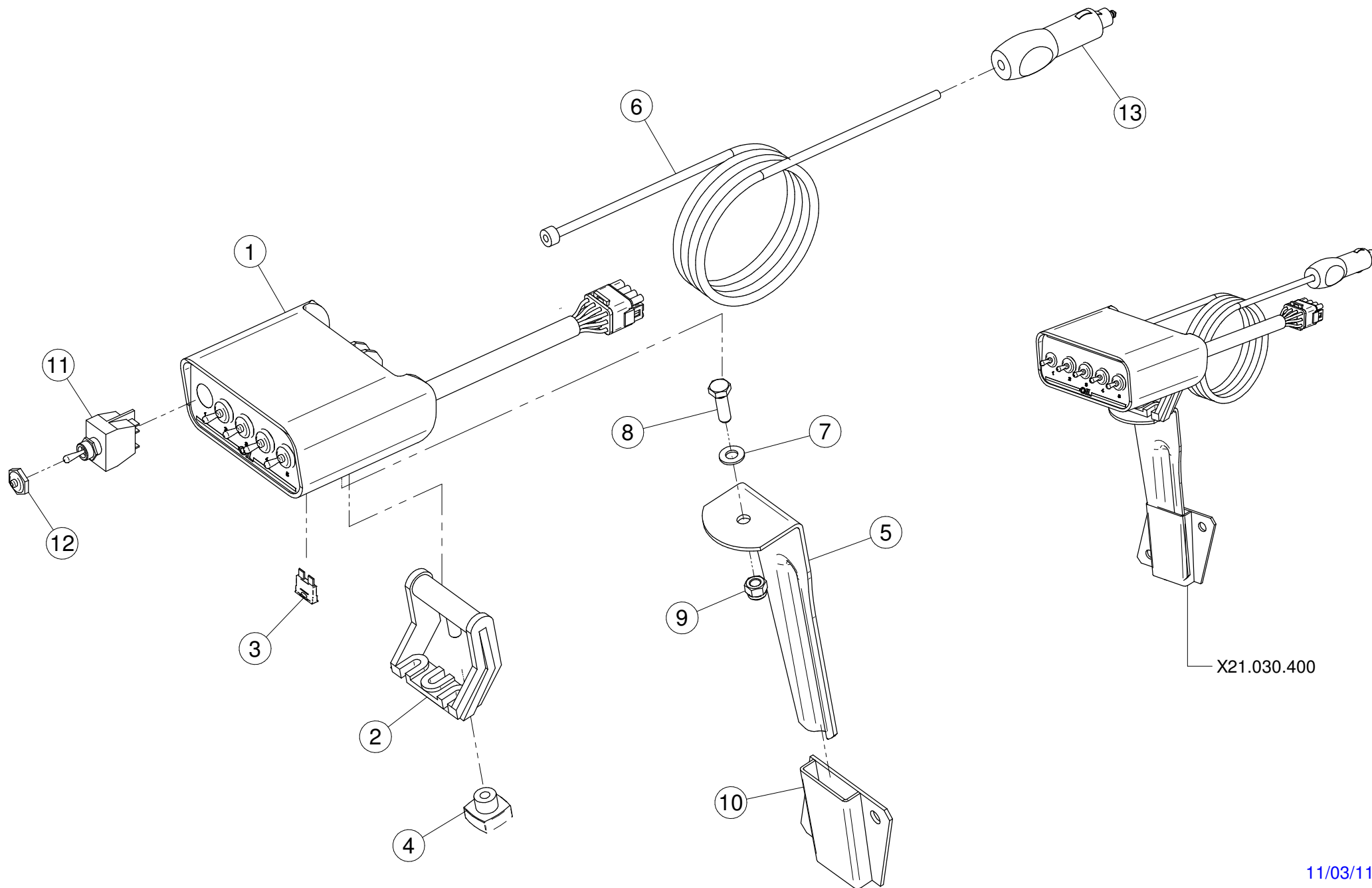

N°	Doc. Number	Titolo	Title	Q.tà	Note
1	X21.056.001	Scatola di comando (non fornito)	Switch box (not supplied)	1	
2	X21.030.002	Staffa di fissaggio mobile	Moving fixing bracket	1	
3	X21.030.004	Fusibile - 10 Ah	10 Ah Fuse	1	
4	X21.030.003	Pomello di bloccaggio	Fixing knob	1	
5	X20.111.000	Staffa porta baionetta	Bracket	1	
6	X02.401.182	Cavo di alimentazione D.1x 2 L=1820	Power cable D.1 x 2 L=1820	1	
7	XRP.008.000	Rondella piana d. 8	Washer d. 8	1	
8	XTE.008.025T	Vite TE M8 x 25	Screw TE M8 x 25	1	
9	XDA.008.0AG	Dado autobloccante M8	Self locking nut M8	1	
10	X20.107.000	Supporto a baionetta femmina	Female bayonet support	1	
11	X21.030.006	Deviatore ON - 0 - ON 10A	Switch ON - 0 - ON 10A	5	
12	X21.030.007	Cappuccio interruttore D.12	Switch cap	5	
13	X21.030.008	Connettore di alimentazione 12V	12V Power jack	1	

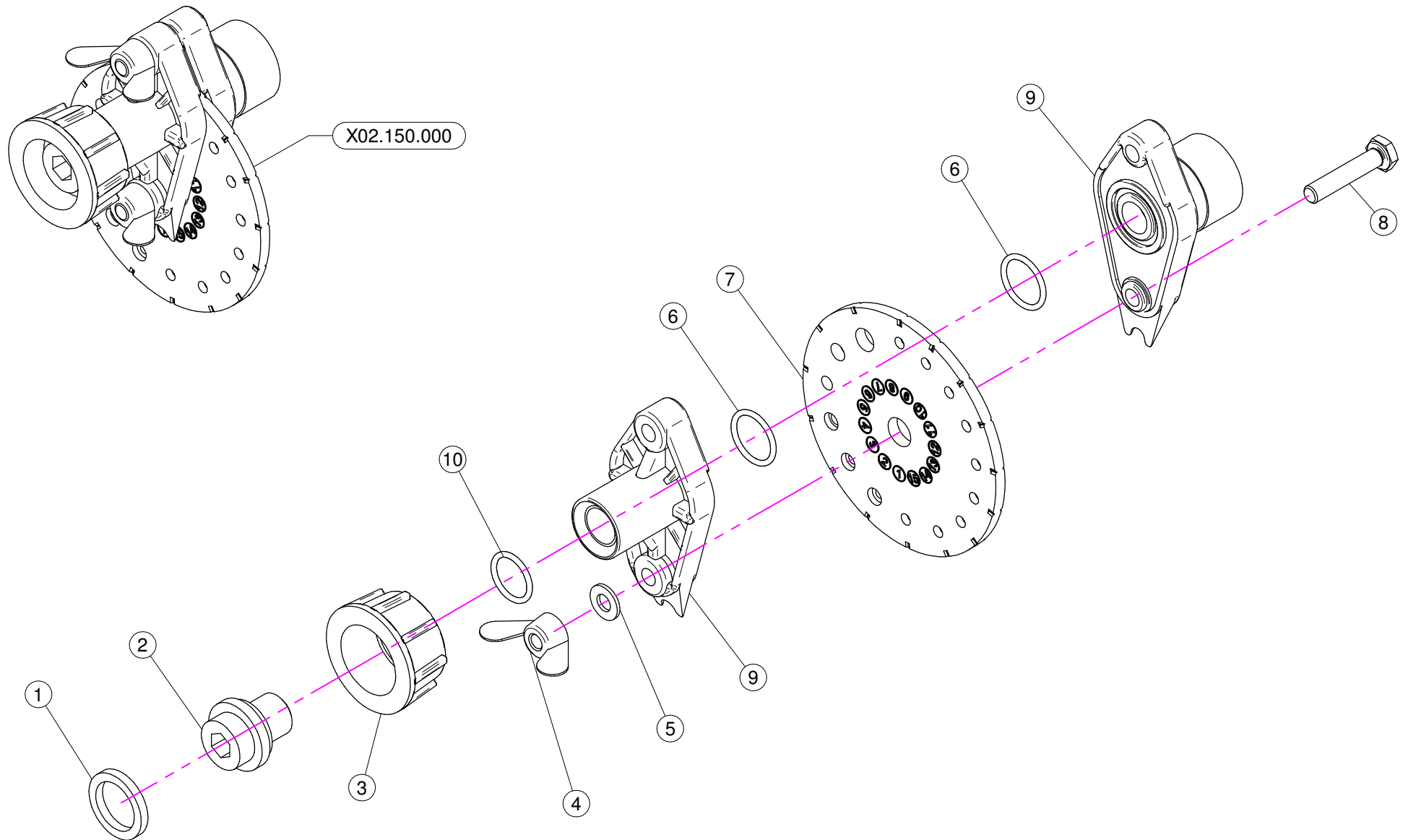

N°	Doc. Number	Titolo	Title	Q.tà	Note
1	X02.349.000	GUARNIZIONE PIANA D.17X23X3	17X23X3 FLAT GASKET	1	
2	X02.117.000	NIPPLO M14X1.5/D.17	ADAPTOR NIPPLE	1	
3	X00.055.045	GIRELLO 3/4" GAS	3/4" FLY NUT	1	
4	XDF.OTT.006	DADO AD ALETTE IN OTTONE M6	WING NUT M6	2	
5	XRP.006.000I	RONDELLA PIANA D. 6 INOX	INOX WASHER D.6	2	
6	XOR.002.062	OR D.15.6X1.78	D.15.6X1.78 OR	2	
7	X02.148.000	DISCO ROTANTE PER REGOLATORE	REGULATOR DISK	1	
8	XTE.006.030I	VITE TE M6X30 INOX	INOX M6X30 BOLT	2	
9	X02.147.500	COPPIA DI SEMICORPO REGOLATORE	REGULATOR HALF-BODY	1	
10	XOR.003.050	OR D.12.37x2.62	O-RING D.12.37x2.62	1	

X02.008.304C

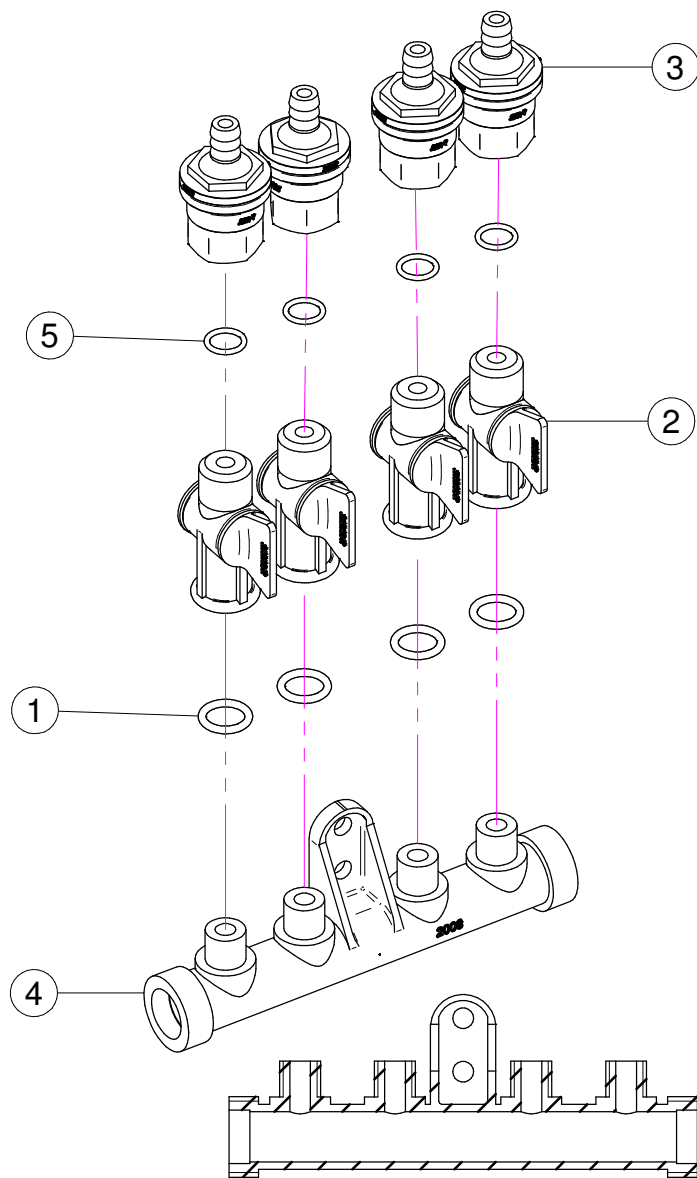

X02.008.404C

DISTRIBUTORE DIVISO
DIVIDED MANIFOLD

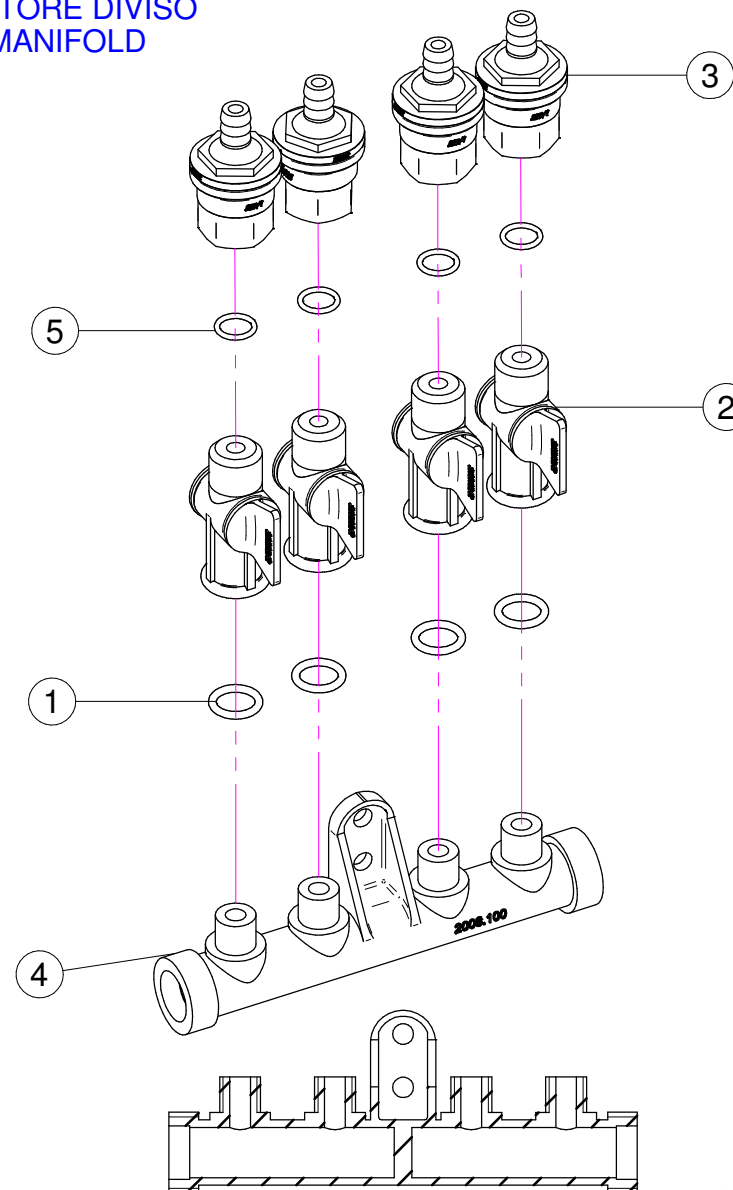

X02.008.304C

N°	Doc. Number	Titolo	Title	Q.tà	Note
1	XOR.000.117	OR D. 13,1x18,34x2,62	13,1x18,34x2;62 O-RING GASKET	4	
2	X20.202.100	RUBINETTO P.G. D.10 F.1/4" GAS TAGLIATO	TAP ASSEMBLY	4	
3	X00.227.01C	DISPOSITIVO ANTIGOCCIA	ANTDRIP VALVE	4	
4	X02.008.000	DISTRIBUTORE LIQUIDO TESTATE	SPRAYHEADS LIQUID MANIFOLD	1	
5	XOR.002.043	OR 10.82X14.38X1.78 NBR70	10.82X14.38X1.78 NBR70 O-RING GASKET	4	

X02.008.404C

N°	Doc. Number	Titolo	Title	Q.tà	Note
1	XOR.000.117	OR D. 13,1x18,34x2,62	13,1x18,34x2;62 O-RING GASKET	4	
2	X20.202.100	RUBINETTO P.G. D.10 F.1/4" GAS TAGLIATO	TAP ASSEMBLY	4	
3	X00.227.01C	DISPOSITIVO ANTIGOCCIA	ANTDRIP VALVE	4	
4	X02.008.100	DISTRIBUTORE LIQUIDO TESTATE DIVISO	DIVIDED SPRAYHEADS LIQUID MANIFOLD	1	
5	XOR.002.043	OR 10.82X14.38X1.78 NBR70	10.82X14.38X1.78 NBR70 O-RING GASKET	4	