

N°	Doc. Number	Titolo	Title	Q.tà	N°	Doc. Number	Titolo	Title	Q.tà
1	X02.408.000	RACCORDO DRITTO PER OCCHIO 1/4"	JACK EYE RIGHT UNION 1/4"	5	43	X50.231.200	TUBO DI ANCORAGGIO	ANCHOR TUBE	1
2	X02.472.000	RONDELLA DI RAME Ø 19x13,5x1,5	COPPER WASHER Ø 19x13,5x1,5	20	44	X50.232.200	TIRANTE DI SOSTEGNO SINISTRO	LEFT TIE-ROD	1
3	X02.838.201C(DX)	MARTINETTO COMPLETO CORSA L=156	COMPLETE JACK	2	45	X50.232.300	TIRANTE DI SOSTEGNO DESTRO	RIGHT TIE-ROD	1
4	X02.838.201C(SX)	MARTINETTO COMPLETO CORSA L=156	COMPLETE JACK	2	46	XD0.10.5587G	DADO M10 6S PG 5587 ZINC.	M10 6S BIG LEAD NUT 5587	22
5	X02.986.002	SEMI FASCETTA SEMPLICE D.175 CON DADO M10	HALF CLAMP WITH NUT M10	2	47	XD0.12.5587G	DADO M12 PG UNI 5587	M12 NUT	42
6	X02.986.102	SEMI FASCETTA SEMPLICE D.175 CON ANELLO	HALF CLAMP	2	48	XD0.20.5589G	DADO BASSO M20	LOWER NUT M20	20
7	X20.718.000	REGOLATORE PORTATA IDRAULICA 1/4"	FLOW REGULATOR 1/4"	6	49	XDA.008.0AG	DADO AUTOBLOCCANTE M8 ALTO PG ZINC.	HIGH BIG LEAD M8 SELFLOCKING	5
8	X20.879.200	LAMIERA COLLEGAMENTO BRACCI	UNION LEG LAMIN	14	50	XDA.010.0AG	DADO AUTOBLOCCANTE M10	SELF LOCKING NUT M10	2
9	X20.884.101	SUPPORTO PALO SCORREVOLE	SLIDING POLE SUPPORT	2	51	XDA.012.0AG	DADO AUTOBLOCCANTE M12	SELF LOCKING NUT M12	22
10	X20.910.300	PERNO ROTAZIONE BRACCI	ARM PIN ROTATION	2	52	XDA.024.0AG	DADO AUTOBLOCCANTE M24	SELF LOCKING M24	2
11	X20.937.000	PIASTRA FISSAGGIO TELAIETTO SOSTEGNO BRACCI	BRACKET	4	53	XDO.24.5589G	DADO BASSO M24	LOWER NUT M24	8
12	X20.937.001	PIASTRA FISSAGGIO SUPPORTO BRACCI	BRACKET	4	54	XID.006.001	INGRASSATORE DIRITTO M6	GREASER	2
13	X20.939.001	SUPPORTO TUBI ROTAZIONE BRACCI	KEEPING ARMS PIPES	2	55	XRP.008.000	RONDELLA PIANA D.8 6592 ZINC.	8 D. FLAT WASHER	10
14	X20.939.101	SUPPORTO TUBI ROTAZIONE BRACCI CON DISCO	KEEPING ARMS PIPES WITH DISK	2	56	XRP.010.000	RONDELLA PIANA D.10 6592 ZINC.	WASHER Ø 10	44
15	X20.940.000	LAMIERA FISSAGGIO TELAIETTO SOSTEGNO BRACCI	BRACKET	2	57	XRP.010.030	RONDELLA PIANA F.LARGA D.10X30 ZINC.	10X30mm D. LARGE THREAD FLAT	8
16	X20.943.100C	APPOGGIO BRACCI A RIPOSO COMPLETO	COMPLETE ARM BLOCK	2	58	XRP.012.000	RONDELLA PIANA Ø12	WASHER Ø12	144
17	X20.948.002.Z	PALO DI DISCESA SNODATO INFERIORE DX ZINCATO	RIGHT LOWER GOING-DOWN PIPE ZINCED	1	59	XRP.012.036	RONDELLA PIANA D12 X 36	WASHER D12 X 36	4
18	X20.948.102.Z	PALO DI DISCESA SNODATO INFERIORE SX ZINCATO	LEFT LOWER GOING-DOWN PIPE ZINCED	1	60	XRP.020.000	RONDELLA PIANA D.20	WASHER D.20	10
19	X20.958.201	TUBO ROTAZIONE BRACCI DX	RIGHT ARMS ROTATION PIPE	1	61	XRP.024.000	RONDELLA PIANA D.24	WASHER D.24	4
20	X20.959.201	TUBO ROTAZIONE BRACCI SX	LEFT ARM ROTATION PIPE	1	62	XRP.024.000	RONDELLA PIANA D.24	WASHER D.24	2
21	X20.969.100	COLLEGAMENTO SCORREVOLE PER BRACCI	SLIDING UNION FOR ARMS	4	63	XS0.480.000	MOLLA PER SERRANDA	SPRING	2
22	X21.019.300	TELAIO FISSO	CENTRAL FRAME	1	64	XS0.493.000	CAVALLOTTO FISSAGGIO CERCHIO PROTEZIONE	SHAPED PLATE FIXING BUMPER	4
23	X21.020.101	BRACCIO SCORREVOLE	SLIDING ARM	4	65	XTE.008.070	VITE TE UNI 5737-65 M8x70-8.8	SCREW TE UNI 5737-65 M8x70-8.8	5
24	X21.022.200	BRACCIO LATERALE DESTRO INFERIORE	RIGHT SIDE ARM	1	66	XTE.010.020T	VITE TE UNI 5739-65 M10x20-8.8	SCREW TE UNI 5739-65 M10x20-8.8	4
25	X21.023.100	BRACCIO LATERALE DESTRO SUPERIORE	HIGH RIGHT ARM	1	67	XTE.010.030T	VITE TE UNI 5739-65 M10x30-8.8	SCREW TE UNI 5739-65 M10x30-8.8	8
26	X21.024.301	TELAIO SCORREVOLE	SLIDING FRAME	1	68	XTE.010.035T	VITE TE UNI 5739-65 M10x35-8.8	SCREW TE UNI 5739-65 M10x35-8.8	16
27	X21.025.200	BRACCIO LATERALE SINISTRO INFERIORE	LOWER LEFT ARM	1	69	XTE.010.040T	VITE TE UNI 5739-65 M10x40-8.8	SCREW TE UNI 5739-65 M10x40-8.8	6
28	X21.026.100	BRACCIO LATERALE DESTRO SUPERIORE	HIGH RIGHT ARM	1	70	XTE.012.030T	VITE TE UNI 5739-65 M12x30-8.8	SCREW TE UNI 5739-65 M12x30-8.8	26
29	X21.027.000	PALO DI DISCESA SNODATO SUPERIORE DX	RIGHT HIGHER GOING-DOWN PIPE	1	71	XTE.012.035T	VITE TE UNI 5739-65 M12X35-8.8	SCREW TE UNI 5739-65 M12X35-8.8	2
30	X21.027.100	PALO DI DISCESA SNODATO SUPERIORE SX	LEFT HIGHER GOING-DOWN PIPE	1	72	XTE.012.080	VITE TE M12X80 5737 ZINC.	BOLT TE M12X80 5737	2
31	X21.115.000	MARTINETTO COMPLETO CORSA L=640	COMPLETE JACK	1	73	XTE.012.090	VITE TE UNI 5737-65 M12x90-8.8	SCREW TE UNI 5737-65 M12x90-8.8	20
32	X50.040.025	ANELLO DI GUIDA IN ACCIAIO INOX	STAINLESS STEEL GUIDE RING	4	74	XTE.012.100	VITE TE UNI 5737-65 M12x100-8.8	SCREW TE UNI 5737-65 M12x100-8.8	24
33	X50.209.000	BRACCIO DI DISCESA SOSTEGNO TESTATA SX	LEFT GOING DOWN ARM	1	75	XTE.012.110	VITE TE UNI 5737-65 M12x110-8.8	SCREW TE UNI 5737-65 M12x110-8.8	16
34	X50.209.100	BRACCIO DI DISCESA SOSTEGNO TESTATA DX	RIGHT GOING DOWN ARM	1	76	XTE.020.080	VITE TE UNI 5737-65 M20x80-8.8	SCREW TE UNI 5737-65 M20x80-8.8	3
35	X50.209.200	BRACCIO DI DISCESA SOSTEGNO TESTATA	GOING-DOWN ARM	2	77	XTE.020.100	VITE TE UNI 5737-65 M20x100-8.8	SCREW TE UNI 5737-65 M20x100-8.8	7
36	X50.211.000	STAFFA ATTACCO DISTRIBUTORE	BRACKET	2	78	XTE.024.100	VITE TE UNI 5737-65 M24x100-8.8	SCREW TE UNI 5737-65 M24x100-8.8	4
37	X50.211.002	PIATTO FISSAGGIO STAFFA ANCORAGGIO	BRACKET	2					
38	X50.226.201	ARCO DI ANCORAGGIO	TIE-ROD	1					
39	X50.227.000	TAMPONE SCORREVOLE	SLIDING BUFFER	2					
40	X50.229.000	TIRANTE	TIE ROD	2					
41	X50.230.201.Z	CAVALLETTO DI SOSTEGNO ZINCATO	KEEPING FRAME ZINCED	1					
42	X50.231.100	TUBO DI ANCORAGGIO	ANCHOR TUBE	1					

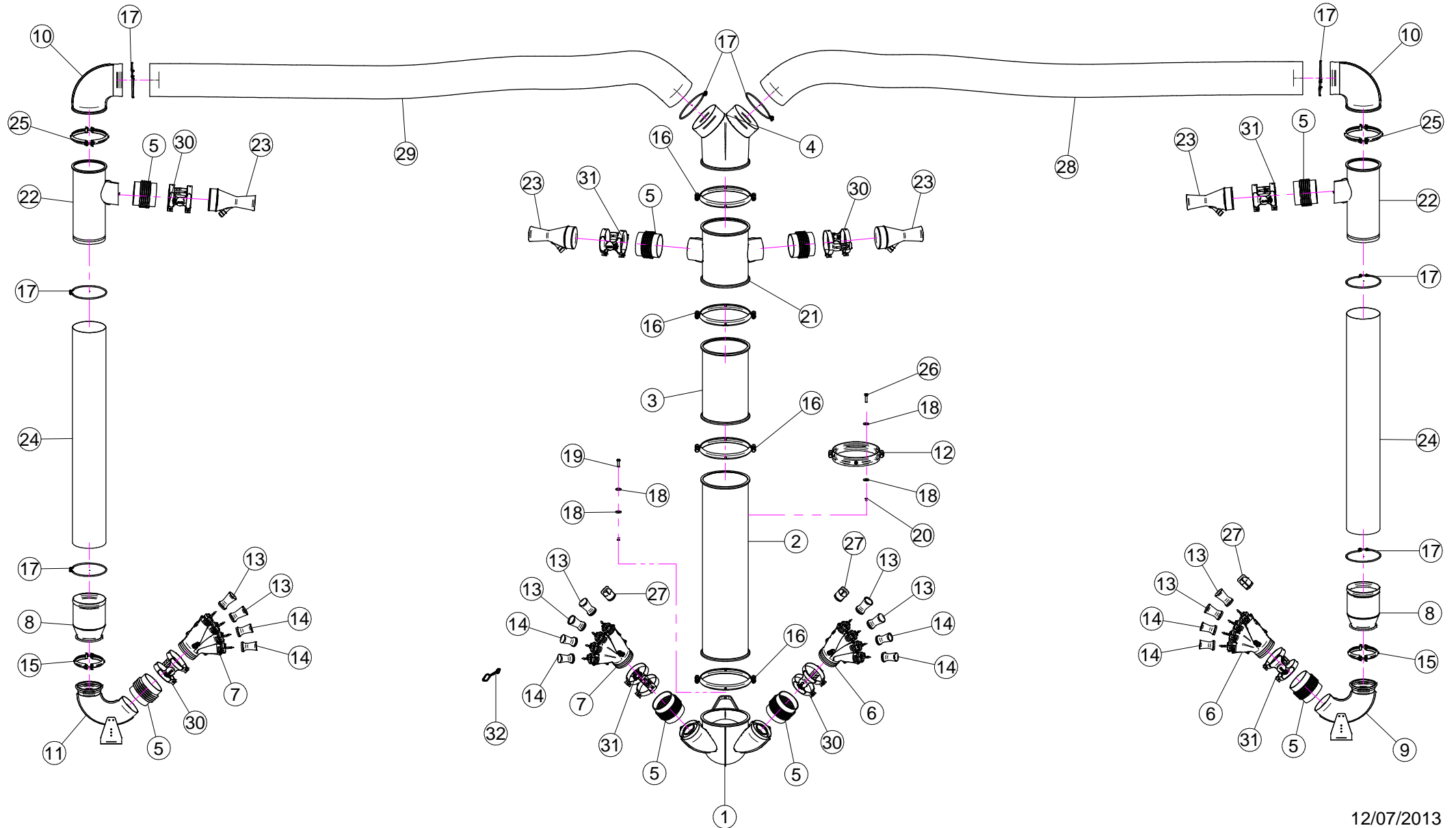

N°	Doc. Number	Titolo	Title	Q.tà	Note
1	X05.843.100	CORPO D.250 CON DUE USCITE D.120 SENZA PRESE D'ARIA	BODY D.250 WITH 2 OUTLETS D.120	1	
2	X50.075.000	PROLUNGA D.250 x 1000	EXTENSION D.250 x 1000	1	
3	X21.100.040	PROLUNGA D.250 x 400	EXTENSION D.250 x 400	1	
4	X20.649.000	CORPO D.250 CON 2 USCITE D.175	BODY D.250 WITH 2 OUTLETS D.175	1	
5	X02.021.000	MANICOTTO FLESSIBILE D.120	FLEXIBLE SLEEVE	8	
6	X20.014.000DX	MANO A 4 USCITE CON TUBETTI	FOUR OUTLETS	2	
7	X20.014.000SX	MANO A 4 USCITE CON TUBETTI	FOUR OUTLETS	2	
8	X02.749.100	RIDUZIONE DA D.175 A D.130 CON P.G.	RIDUCTION FROM D.175 TO D.130 MIT R.H.	2	
9	X04.845.400	CURVA A 130° D.120	ELBOW 130° D.120	1	
10	X20.650.200	CURVA D.175 90° CON PORTAGOMMA D.180	ELBOW D.175 90° WITH RUBBER HOLDER D.180	2	
11	X04.845.300	CURVA A 135° D.120	ELBOW 135° D.120	1	
12	X20.504.000	FASCETTA D.250 FISSAGGIO TESTATE	D.250 CLAMP HEADS FIXING	1	
13	X00.008.050	DIFFUSORE 8/50	NOZZLE 8/50	8	
14	X00.006.050	DIFFUSORE 6/50	NOZZLE 6/50	8	
15	X04.027.000	COLLARE PER TUBI D. 150	PIPE CLAMP D. 150	2	
16	X05.813.010	COLLARE D.275	CLAMP D.275	4	
17	XF0.180.000	FASCETTA UNIFILO D.180	CLAMP D.180	8	
18	XRP.010.030	RONDELLA PIANA D.10 x 30 mm	WASHER D.10 x 30 mm	6	
19	XTE.010.035T	VITE TE 10 x 35	SCREW TE 10 x 35	1	
20	XD0.10.5587G	DADO M10	NUT M10	3	
21	X20.653.000	TRONCHETTO D.250 CON DUE USCITE D.120	BODY D.250 WITH 2 OUTLETS D.120	1	
22	X20.651.100	TRONCHETTO D.175 CON UNA USCITA D.120	BODY D.175 WITH 1 OUTLET D.120	2	
23	X10.018.120	DIFFUSORE 18/120 CON TUBETTO	NOZZLE 18/120	4	
24	X02.388.125	TUBO SPIRALATO D.180 L=1250	HOSE D.180 L=1250	2	
25	X05.616.000	COLLARE PER TUBI D.175	PIPE CLAMP D.175	2	
26	XTE.010.040T	VITE TE M10 x 40	SCREW TE M10 x 40	2	
27	X02.127.000	TAPPO DI ATTACCO RAPIDO	CAP NOZZLE PLUG	3	
28	X02.388.400	TUBO SPIRALATO D.180 L=4000	HOSE SPIRALATO D.180 L=4000	1	
29	X02.388.400	TUBO SPIRALATO D.180 L=4000	HOSE SPIRALATO D.180 L=4000	1	
30	X21.080.000	COPPIA FASCETTE Ø 127 DESTRA	RIGHT CLAMP Ø 127	4	
31	X21.081.000	COPPIA FASCETTE Ø 127 SINISTRA	LEFT CLAMP Ø 127	4	
32	X20.697.000	FERMA DIFFUSORE	NOZZLE STOP	16	

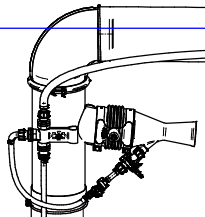

Sheet
2/4

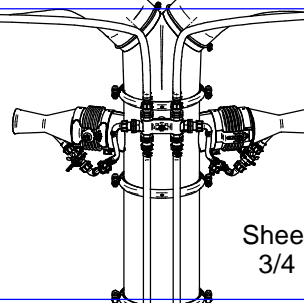

Sheet
3/4

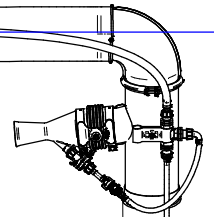

Sheet
2/4

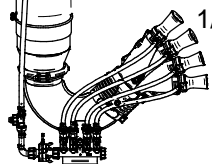

Sheet
1/4

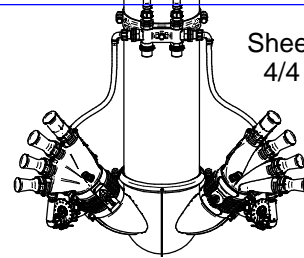

Sheet
4/4

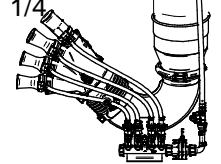

Sheet
1/4

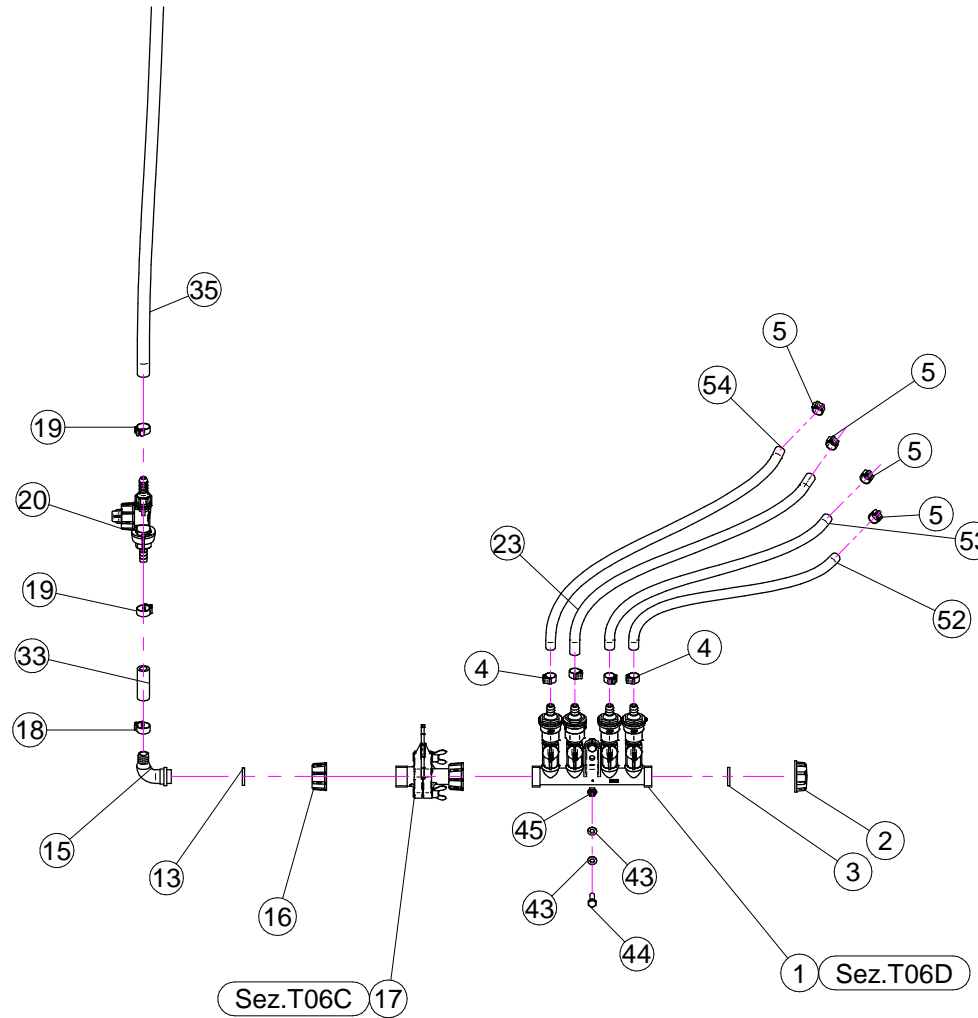

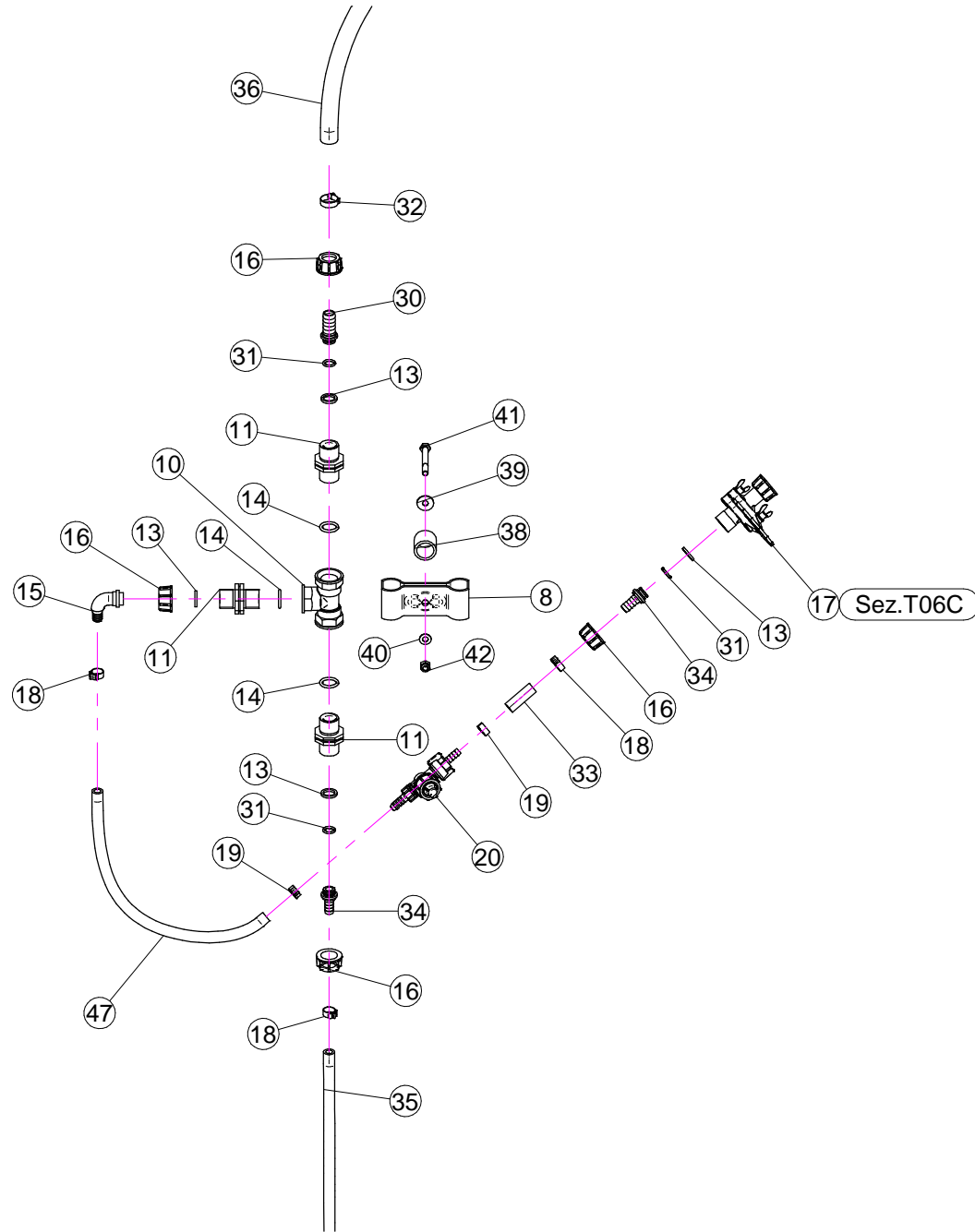

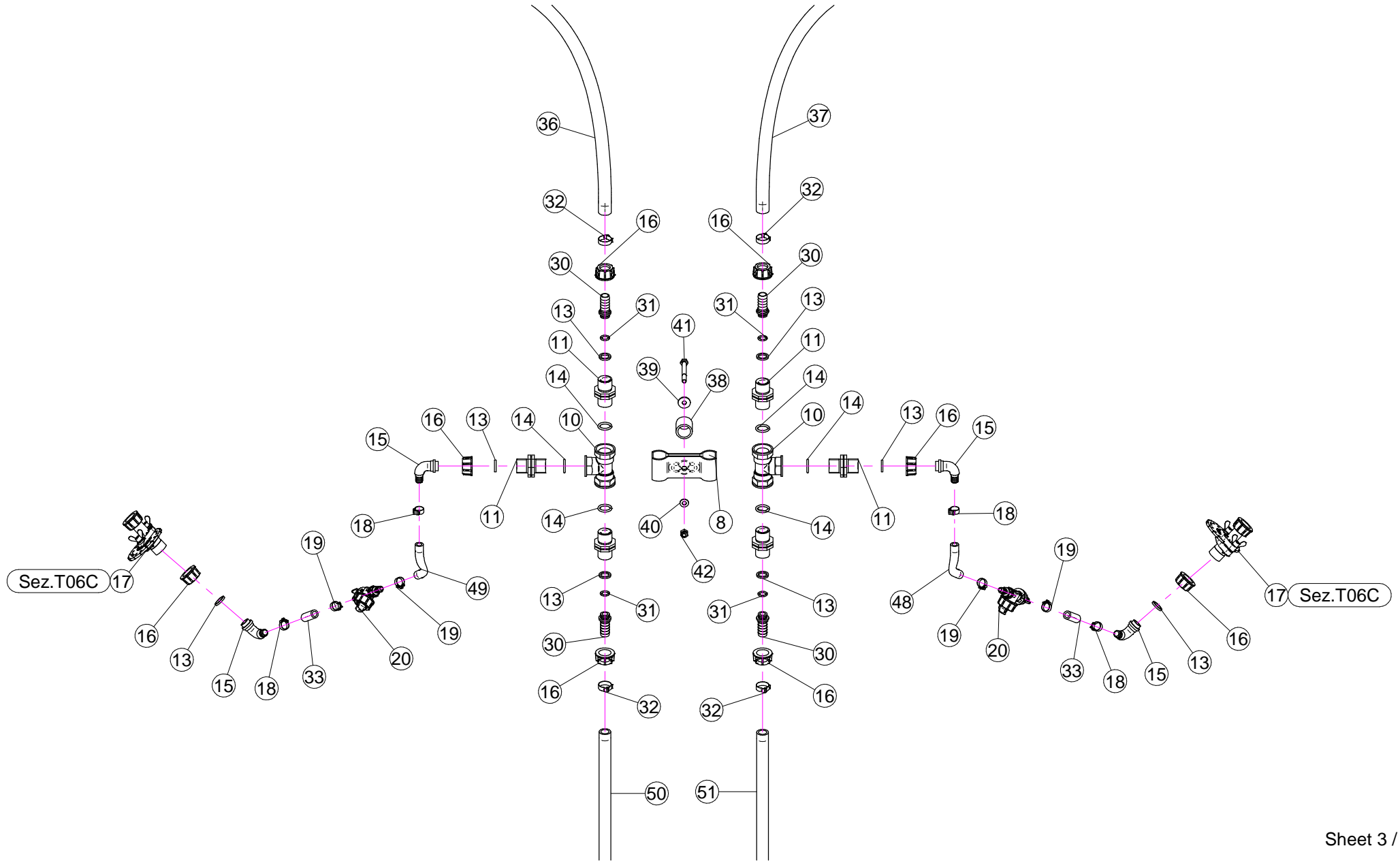

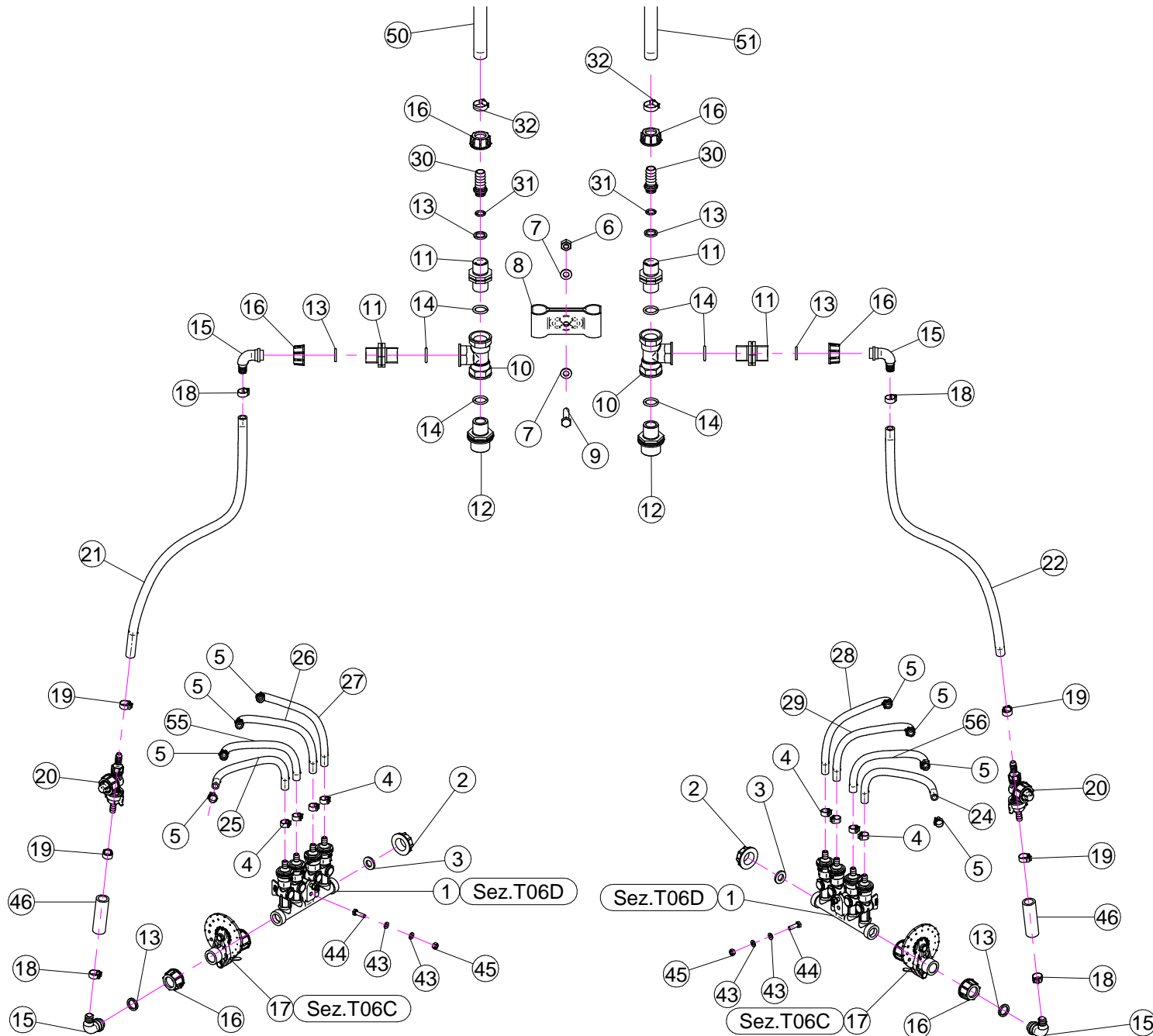

N°	Doc. Number	Titolo	Title	Q.tà	Note
1	X02.008.304C	DISTRIBUTORE LIQUIDI A 4 RUBINETTI	4 TAPS LIQUID MANIFOLD	4	
2	X02.182.000	TAPPO 3/4" FEMMINA	FEMALE 3/4" CAP	4	
3	X02.030.010	GUARNIZIONE TAPPO DISTRIBUTORE	GASKET	4	
4	XFC.013,5.015	FASCETTA COBRA SLO30710	KOBRA CLAMP	16	
5	XFC.012,5.014	FASCETTA COBRA SLO30705	KOBRA CLAMP	16	
6	XDA.010.0AG	DADO AUTOBLOCCANTE M10	SELF LOCKING NUT M10	1	
7	XRP.010.000	RONDELLA PIANA D.10	WASHER D.10	2	
8	X02.999.000	STAFFA FISSAGGIO RACCORDO A T	T UNION FIXING BRACKET	4	
9	XTE.010.040T	VITE TE M10 x 40	SCREW TE M10 x 40	1	
10	X02.396.000	RACCORDO A T 3/4" - 3/4" - 3/4" F.	UNION 3/4" - 3/4" - 3/4" F.	6	
11	X02.380.000	NIPPLO 3/4"	NIPPLE 3/4"	16	
12	X02.293.000	RIDUZIONE 1" M - 3/4" M	1" M - 3/4" M REDUCER NIPPLE	2	
13	X02.349.000	GUARNIZIONE PIANA D.17X23X3	17X23X3 FLAT GASKET	24	
14	XOR.004.081	OR D.20,22 x 3,53	20,22 x 3,53 O-RING GASKET	18	
15	X00.055.046R	RACCORDO CURVO P.G. D.14	CURVED UNION WITH R.H. D.14	12	
16	X00.055.045	GIRELLO 3/4" GAS	3/4" FLY NUT	24	
17	X02.150.000	REGOLATORE A DISCO ROTANTE COMPLETO	ROTATION DISK REGULATION	8	
18	XFC.016,5.018	FASCETTA COBRA 16,5 - 18	KOBRA CLAMP 16,5 - 18	16	
19	XFC.015,5.017	FASCETTA COBRA SLO30720	KOBRA CLAMP	16	
20	X00.226.05C	GETTO ANTIGOCCIA DIRITTO COMPLETO	COMPLETE ANTIDROP	8	
21	X02.213.060	TUBO D.10 x 16 L=600	HOSE D.10 x 16 L=600	1	
22	X02.213.060	TUBO D.10 x 16 L=600	HOSE D.10 x 16 L=600	1	
23	X02.217.039	TUBO D. 8 x 13 L=390	HOSE D. 8 x 13 L=390	2	
24	X02.217.031	TUBO D. 8 x 13 L=310	HOSE D. 8 x 13 L=310	1	
25	X02.217.031	TUBO D. 8 x 13 L=310	HOSE D. 8 x 13 L=310	1	
26	X02.217.039	TUBO D. 8 x 13 L=390	HOSE D. 8 x 13 L=390	1	
27	X02.217.041	TUBO D. 8 x 13 L=410	HOSE D. 8 x 13 L=410	1	
28	X02.217.041	TUBO D. 8 x 13 L=410	HOSE D. 8 x 13 L=410	1	

N°	Doc. Number	Titolo	Title	Q.tà	Note
29	X02.217.039	TUBO D. 8 x 13 L=390	HOSE D. 8 x 13 L=390	1	
30	X02.002.000	RACCORDO DIRITTO 3/4" P.G.18	STRAIGHT UNION 3/4" R.H.18	8	
31	XOR.000.117	OR D. 13,1x18,34x2,62	13,1x18,34x2,62 O-RING GASKET	12	
32	XFC.023,5.025	FASCETTA COBRA 23,5 - 25	KOBRA CLAMP 23,5 - 25	8	
33	X02.213.007	TUBO D.10 x 16 L=70	HOSE D.10 x 16 L=70	6	
34	X02.122.000	RACCORDO A P.G. D.13	D.13 UNION	4	
35	X02.213.170	TUBO D.10 x 16 L=1700	HOSE D.10 x 16 L=1700	2	
36	X02.211.600	TUBO D.16 x 23 L=6000	HOSE D.16 x 23 L=6000	1	
37	X02.211.600	TUBO D.16 x 23 L=6000	HOSE D.16 x 23 L=6000	1	
38	X02.219.035	TUBO D.25 x 32 L=35	HOSE D.25 x 32 L=35	3	
39	XRP.008.024	RONDELLA PIANA LARGA D.8X24	WASHER D.8X24	3	
40	XRP.008.000	RONDELLA PIANA D.8	WASHER D.8	3	
41	XTE.008.070	VITE TE M8x70	SCREW TE M8x70	3	
42	XDA.008.0AG	DADO AUTOBLOCCANTE M8	SELF LOCKING NUT M8	3	
43	XRP.006.000	RONDELLA PIANA D. 6	WASHER D.6	16	
44	XTE.006.020T	VITE TE M6 x 20	SCREW TE M6 x 20	8	
45	XD0.06.5588G	DADO M6	NUT M6	8	
46	X02.211.007	TUBO D. 16 x 23 L= 70	HOSE D. 16 x 23 L= 70	2	
47	X02.213.030	TUBO D.10x16 L=300	HOSE D.10x16 L=300	2	
48	X02.213.020	TUBO D.10x16 L=200	HOSE D.10x16 L=200	1	
49	X02.213.020	TUBO D.10x16 L=200	HOSE D.10x16 L=200	1	
50	X02.211.100	TUBO D.16x23 L=1000	HOSE D.16x23 L=1000	1	
51	X02.211.100	TUBO D.16x23 L=1000	HOSE D.16x23 L=1000	1	
52	X02.217.031	TUBO D.8x13 L=310	HOSE D.8x13 L=310	2	
53	X02.217.035	TUBO D.8x13 L=350	HOSE D.8x13 L=350	2	
54	X02.217.041	TUBO D.8x13 L=410	HOSE D.8x13 L=410	2	
55	X02.217.035	TUBO D.8x13 L=350	HOSE D.8x13 L=350	1	
56	X02.217.035	TUBO D.8x13 L=350	HOSE D.8x13 L=350	1	

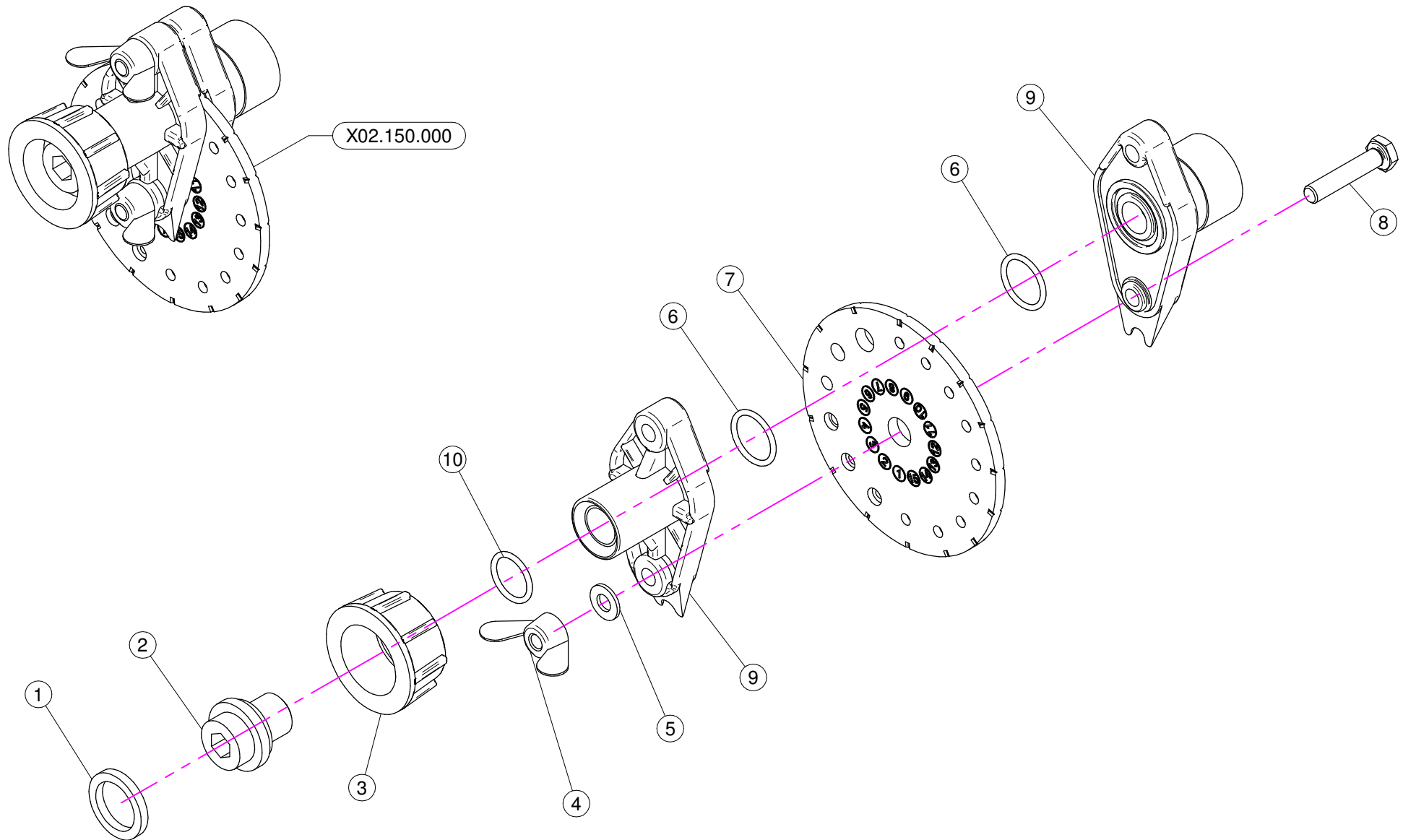

N°	Doc. Number	Titolo	Title	Q.tà	Note
1	X02.349.000	GUARNIZIONE PIANA D.17X23X3	17X23X3 FLAT GASKET	1	
2	X02.117.000	NIPPLO M14X1.5/D.17	ADAPTOR NIPPLE	1	
3	X00.055.045	GIRELLO 3/4" GAS	3/4" FLY NUT	1	
4	XDF.OTT.006	DADO AD ALETTE IN OTTONE M6	WING NUT M6	2	
5	XRP.006.000I	RONDELLA PIANA D. 6 INOX	INOX WASHER D.6	2	
6	XOR.002.062	OR D.15.6X1.78	D.15.6X1.78 OR	2	
7	X02.148.000	DISCO ROTANTE PER REGOLATORE	REGULATOR DISK	1	
8	XTE.006.030I	VITE TE M6X30 INOX	INOX M6X30 BOLT	2	
9	X02.147.500	COPPIA DI SEMICORPO REGOLATORE	REGULATOR HALF-BODY	1	
10	XOR.003.050	OR D.12.37x2.62	O-RING D.12.37x2.62	1	

X02.008.304C

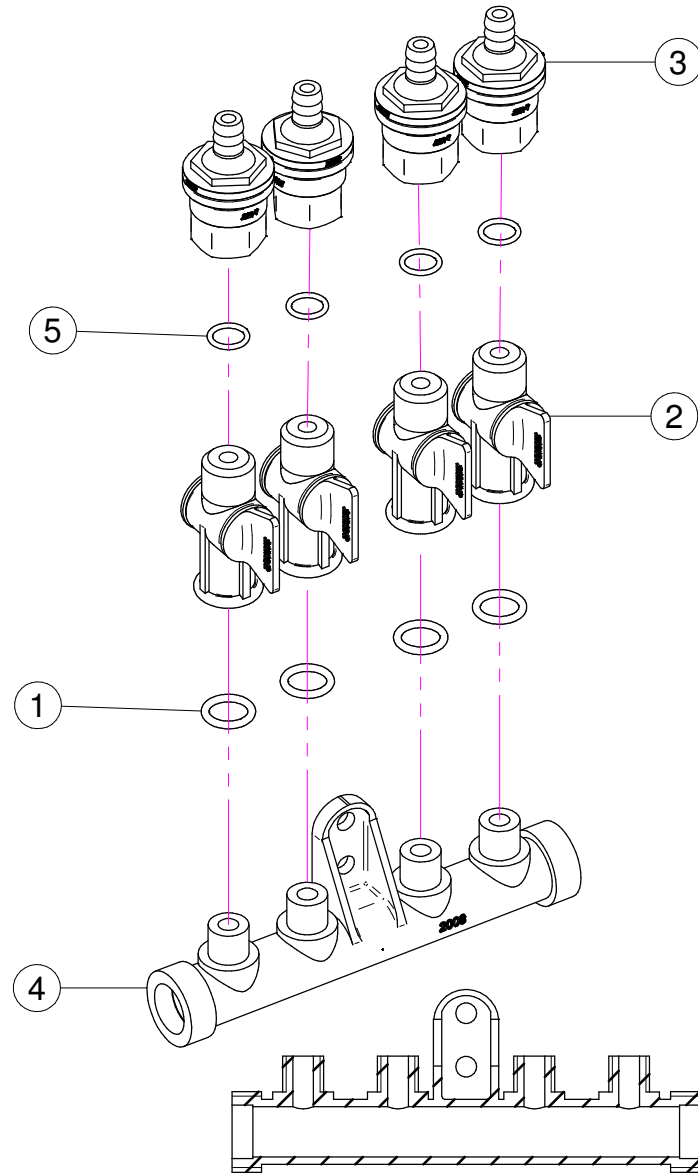

X02.008.404C

DISTRIBUTORE DIVISO
DIVIDED MANIFOLD

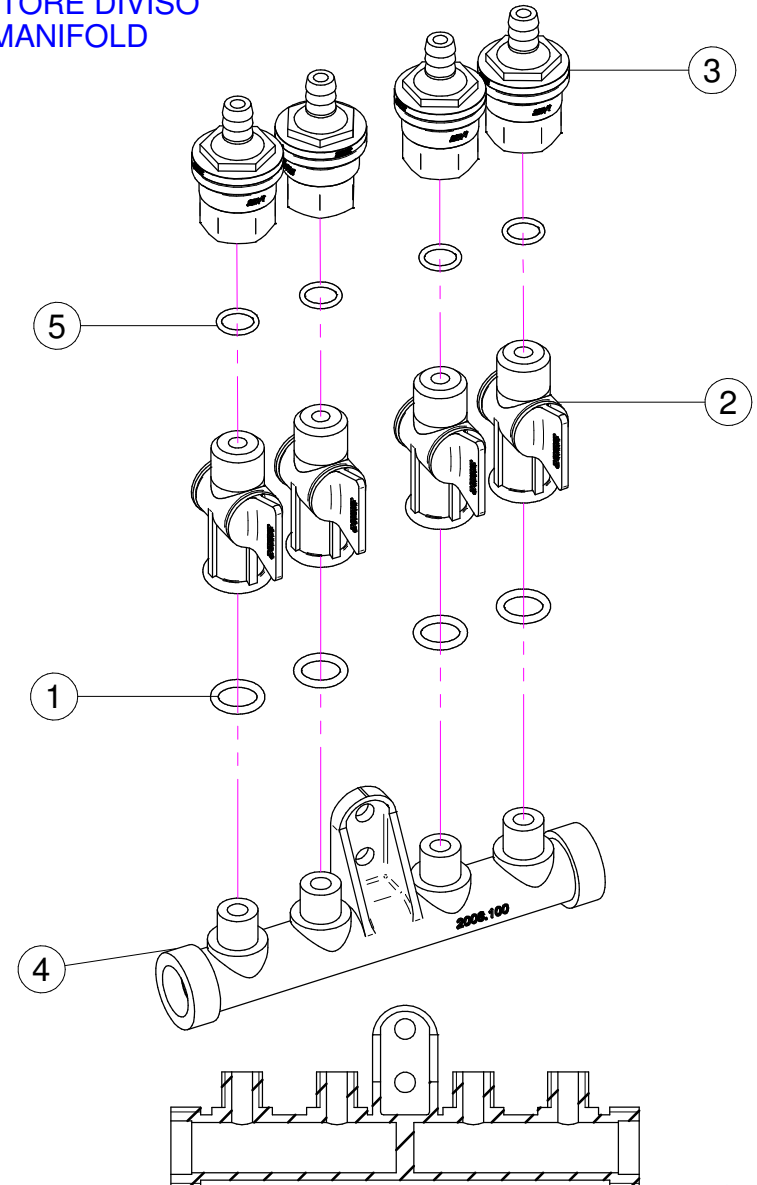

X02.008.304C

N°	Doc. Number	Titolo	Title	Q.tà	Note
1	XOR.000.117	OR D. 13,1x18,34x2,62	13,1x18,34x2;62 O-RING GASKET	4	
2	X20.202.100	RUBINETTO P.G. D.10 F.1/4" GAS TAGLIATO	TAP ASSEMBLY	4	
3	X00.227.01C	DISPOSITIVO ANTIGOCCIA	ANTDRIP VALVE	4	
4	X02.008.000	DISTRIBUTORE LIQUIDO TESTATE	SPRAYHEADS LIQUID MANIFOLD	1	
5	XOR.002.043	OR 10.82X14.38X1.78 NBR70	10.82X14.38X1.78 NBR70 O-RING GASKET	4	

X02.008.404C

N°	Doc. Number	Titolo	Title	Q.tà	Note
1	XOR.000.117	OR D. 13,1x18,34x2,62	13,1x18,34x2;62 O-RING GASKET	4	
2	X20.202.100	RUBINETTO P.G. D.10 F.1/4" GAS TAGLIATO	TAP ASSEMBLY	4	
3	X00.227.01C	DISPOSITIVO ANTIGOCCIA	ANTDRIP VALVE	4	
4	X02.008.100	DISTRIBUTORE LIQUIDO TESTATE DIVISO	DIVIDED SPRAYHEADS LIQUID MANIFOLD	1	
5	XOR.002.043	OR 10.82X14.38X1.78 NBR70	10.82X14.38X1.78 NBR70 O-RING GASKET	4	