

(⌘) A richiesta / Optional Devices

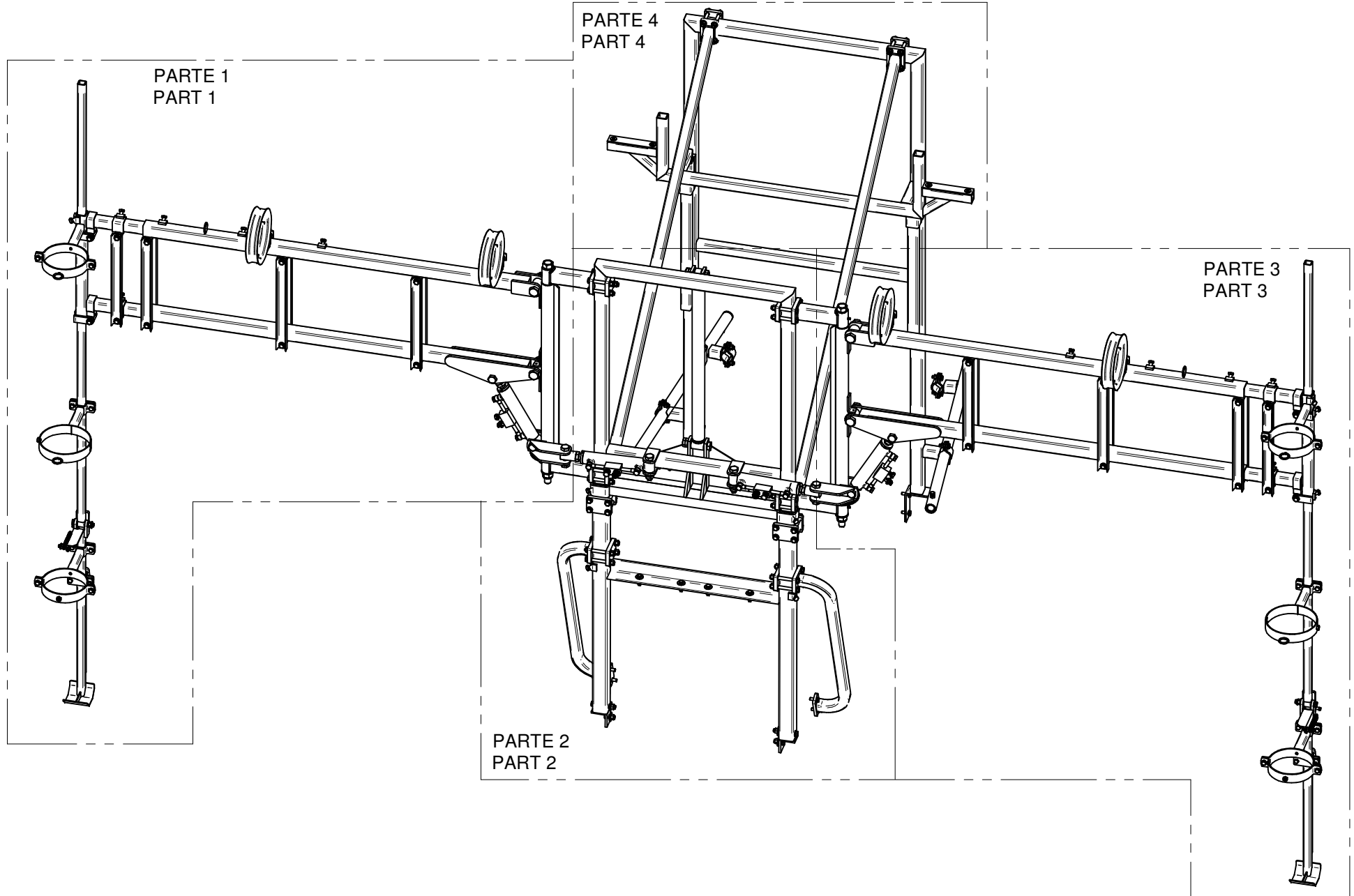

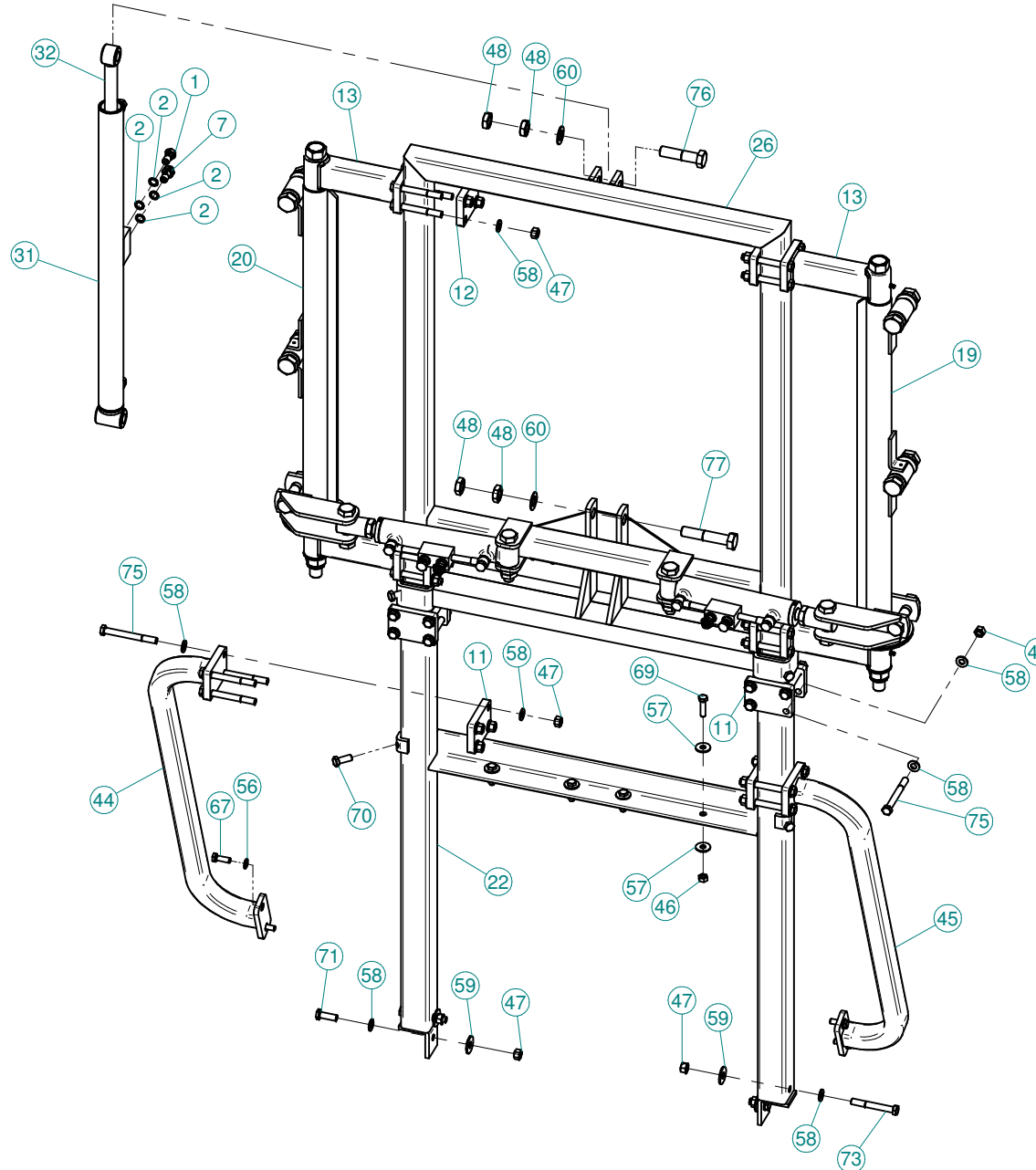

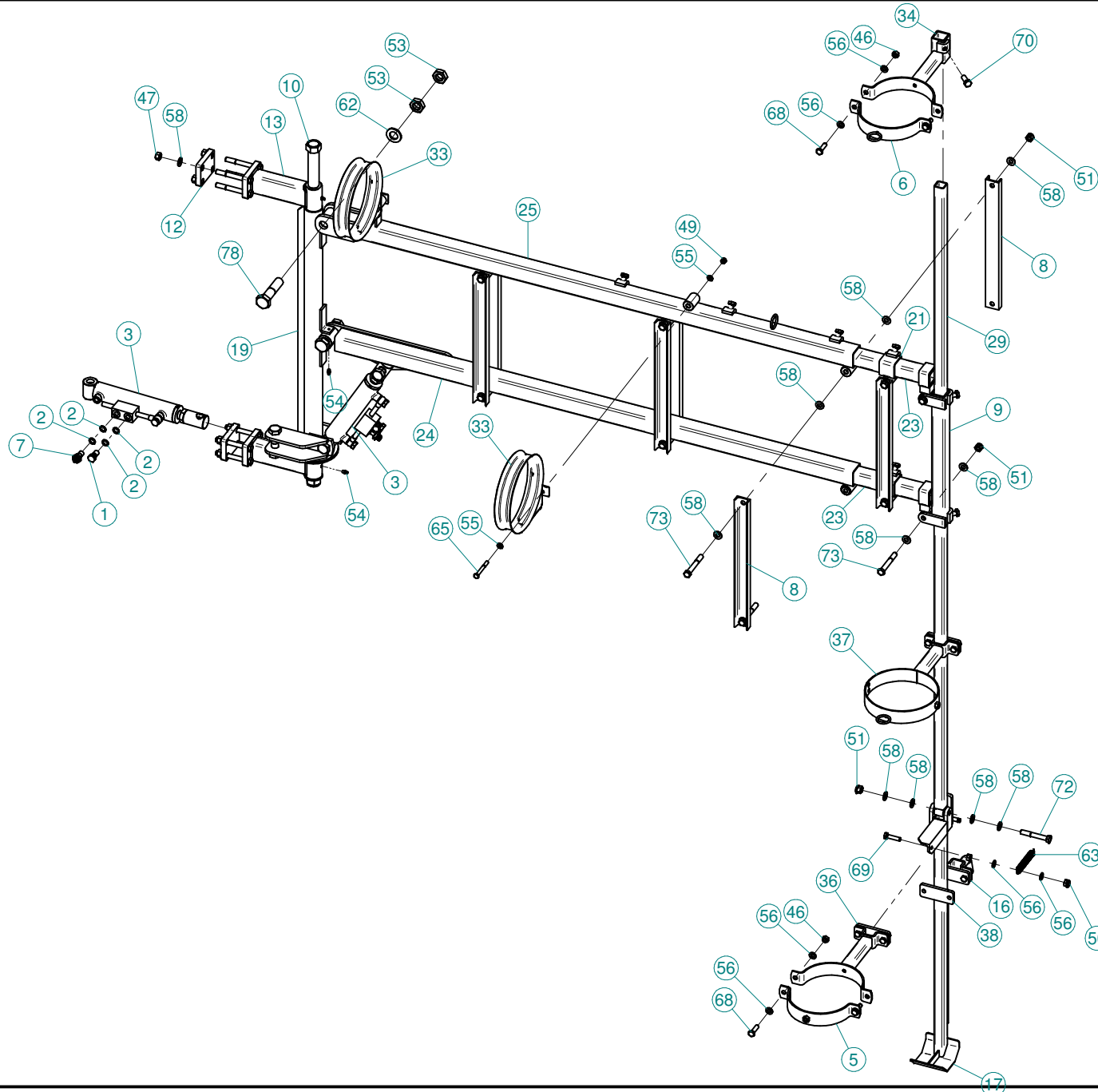

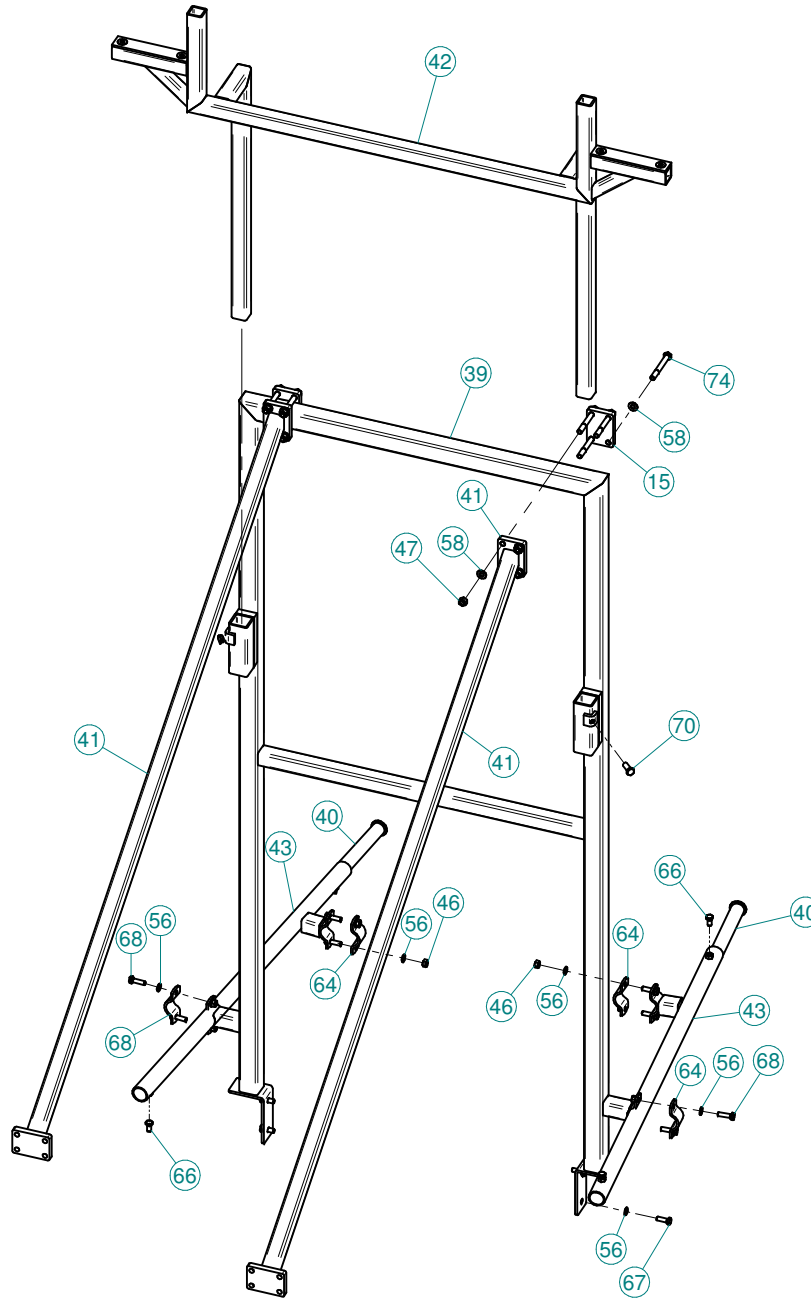

N°	Doc. Number	Titolo	Title	Q.tà	N°	Doc. Number	Titolo	Title	Q.tà
1	X02.408.000	RACCORDO DRITTO PER OCCHIO 1/4"	JACK EYE RIGHT UNION 1/4"	5	56	XRP.010.000	RONDELLA PIANA D.10 6592 ZINC.	WASHER Ø 10	44
2	X02.472.000	RONDELLA DI RAME Ø 19x13,5x1,5	COPPER WASHER Ø 19x13,5x1,5	20	57	XRP.010.030	RONDELLA PIANA F.LARGA D.10X30 ZINC.	10X30mm D. LARGE THREAD FLAT	8
3	X02.838.201C(DX)	MARTINETTO COMPLETO CORSA L=156	COMPLETE JACK	2	58	XRP.012.000	RONDELLA PIANA Ø12	WASHER Ø12	148
4	X02.838.201C(SX)	MARTINETTO COMPLETO CORSA L=156	COMPLETE JACK	2	59	XRP.012.036	RONDELLA PIANA D12 X 36	WASHER D12 X 36	4
5	X02.986.002	SEMI FASCETTA SEMPLICE D.175 CON DADO M10	HALF CLAMP WITH NUT M10	2	60	XRP.020.000	RONDELLA PIANA D.20	WASHER D.20	10
6	X02.986.102	SEMI FASCETTA SEMPLICE D.175 CON ANELLO	HALF CLAMP	2	61	XRP.024.000	RONDELLA PIANA D.24	WASHER D.24	2
7	X20.718.000	REGOLATORE PORTATA IDRAULICA 1/4"	FLOW REGULATOR 1/4"	5	62	XRP.024.000	RONDELLA PIANA D.24	WASHER D.24	4
8	X20.879.200	LAMIERA COLLEGAMENTO BRACCI	UNION LEG LAMIN	14	63	XS0.480.000	MOLLA PER SERRANDA	SPRING	2
9	X20.884.101	SUPPORTO PALO SCORREVOLE	SLIDING POLE SUPPORT	2	64	XS0.493.000	CAVALLOTTO FISSAGGIO CERCHIO PROTEZIONE	SHAPED PLATE FIXING BUMPER	4
10	X20.910.300	PERNO ROTAZIONE BRACCI	ARM PIN ROTATION	2	65	XTE.008.070	VITE TE UNI 5737-65 M8x70-8.8	SCREW TE UNI 5737-65 M8x70-8.8	5
11	X20.937.000	PIASTRA FISSAGGIO TELAIETTO SOSTEGNO BRACCI	BRACKET	4	66	XTE.010.020T	VITE TE UNI 5739-65 M10x20-8.8	SCREW TE UNI 5739-65 M10x20-8.8	4
12	X20.937.001	PIASTRA FISSAGGIO SUPPORTO BRACCI	BRACKET	4	67	XTE.010.030T	VITE TE UNI 5739-65 M10x30-8.8	SCREW TE UNI 5739-65 M10x30-8.8	8
13	X20.939.001	SUPPORTO TUBI ROTAZIONE BRACCI	KEEPING ARMS PIPES	2	68	XTE.010.035T	VITE TE UNI 5739-65 M10x35-8.8	SCREW TE UNI 5739-65 M10x35-8.8	16
14	X20.939.101	SUPPORTO TUBI ROTAZIONE BRACCI CON DISCO	KEEPING ARMS PIPES WITH DISK	2	69	XTE.010.040T	VITE TE UNI 5739-65 M10x40-8.8	SCREW TE UNI 5739-65 M10x40-8.8	6
15	X20.940.000	LAMIERA FISSAGGIO TELAIETTO SOSTEGNO BRACCI	BRACKET	2	70	XTE.012.030T	VITE TE UNI 5739-65 M12x30-8.8	SCREW TE UNI 5739-65 M12x30-8.8	26
16	X20.943.100C	APPOGGIO BRACCI A RIPOSO COMPLETO	COMPLETE ARM BLOCK	2	71	XTE.012.035T	VITE TE UNI 5739-65 M12X35-8.8	SCREW TE UNI 5739-65 M12X35-8.8	2
17	X20.948.002.Z	PALO DI DISCESA SNODATO INFERIORE DX ZINCATO	RIGHT LOWER GOING-DOWN PIPE ZINCED	1	72	XTE.012.080	VITE TE M12X80 5737 ZINC.	BOLT TE M12X80 5737	2
18	X20.948.102.Z	PALO DI DISCESA SNODATO INFERIORE SX ZINCATO	LEFT LOWER GOING-DOWN PIPE ZINCED	1	73	XTE.012.090	VITE TE UNI 5737-65 M12x90-8.8	SCREW TE UNI 5737-65 M12x90-8.8	22
19	X20.958.201	TUBO ROTAZIONE BRACCI DX	RIGHT ARMS ROTATION PIPE	1	74	XTE.012.100	VITE TE UNI 5737-65 M12x100-8.8	SCREW TE UNI 5737-65 M12x100-8.8	24
20	X20.959.201	TUBO ROTAZIONE BRACCI SX	LEFT ARM ROTATION PIPE	1	75	XTE.012.110	VITE TE UNI 5737-65 M12x110-8.8	SCREW TE UNI 5737-65 M12x110-8.8	16
21	X20.969.100	COLLEGAMENTO SCORREVOLE PER BRACCI	SLIDING UNION FOR ARMS	4	76	XTE.020.080	VITE TE UNI 5737-65 M20x80-8.8	SCREW TE UNI 5737-65 M20x80-8.8	3
22	X21.019.300	TELAIO FISSO	CENTRAL FRAME	1	77	XTE.020.100	VITE TE UNI 5737-65 M20x100-8.8	SCREW TE UNI 5737-65 M20x100-8.8	7
23	X21.020.101	BRACCIO SCORREVOLE	SLIDING ARM	4	78	XTE.024.100	VITE TE UNI 5737-65 M24x100-8.8	SCREW TE UNI 5737-65 M24x100-8.8	4
24	X21.022.200	BRACCIO LATERALE DESTRO INFERIORE	RIGHT SIDE ARM	1					
25	X21.023.100	BRACCIO LATERALE DESTRO SUPERIORE	HIGH RIGHT ARM	1					
26	X21.024.301	TELAIO SCORREVOLE	SLIDING FRAME	1					
27	X21.025.200	BRACCIO LATERALE SINISTRO INFERIORE	LOWER LEFT ARM	1					
28	X21.026.100	BRACCIO LATERALE DESTRO SUPERIORE	HIGH RIGHT ARM	1					
29	X21.027.000	PALO DI DISCESA SNODATO SUPERIORE DX	RIGHT HIGHER GOING-DOWN PIPE	1					
30	X21.027.100	PALO DI DISCESA SNODATO SUPERIORE SX	LEFT HIGHER GOING-DOWN PIPE	1					
31	X21.115.000A	MARTINETTO COMPLETO CORSA L=640	COMPLETE JACK	1					
32	X21.115.000B	STELO PER MARTINETTO	CYLINDER ROD	1					
33	X50.040.025	ANELLO DI GUIDA IN ACCIAIO INOX	STAINLESS STEEL GUIDE RING	4					
34	X50.209.000	BRACCIO DI DISCESA SOSTEGNO TESTATA SX	LEFT GOING DOWN ARM	1					
35	X50.209.100	BRACCIO DI DISCESA SOSTEGNO TESTATA DX	RIGHT GOING DOWN ARM	1					
36	X50.209.200	BRACCIO DI DISCESA SOSTEGNO TESTATA	GOING-DOWN ARM	2					
37	X50.211.000	STAFFA ATTACCO DISTRIBUTORE	BRACKET	2					
38	X50.211.002	PIATTO FISSAGGIO STAFFA ANCORAGGIO	BRACKET	2					
39	X50.226.750	ARCO DI ANCORAGGIO	TIE-ROD	1					
40	X50.227.000	TAMPONE SCORREVOLE	SLIDING BUFFER	2					
41	X50.229.800	TIRANTE	TIE ROD	2					
42	X50.230.201.Z	CAVALLETTO DI SOSTEGNO ZINCATO	KEEPING FRAME ZINCED	1					
43	X50.231.000	TUBO DI ANCORAGGIO	ANCHOR TUBE	2					
44	X50.232.200	TIRANTE DI SOSTEGNO SINISTRO	LEFT TIE-ROD	1					
45	X50.232.300	TIRANTE DI SOSTEGNO DESTRO	RIGHT TIE-ROD	1					
46	XD0.10.5587G	DADO M10 6S PG 5587 ZINC.	M10 6S BIG LEAD NUT 5587	22					
47	XD0.12.5587G	DADO M12 PG UNI 5587	M12 NUT	44					
48	XD0.20.5589G	DADO BASSO M20	LOWER NUT M20	20					
49	XDA.008.0AG	DADO AUTOBLOCCANTE M8 ALTO PG ZINC.	HIGH BIG LEAD M8 SELFLOCKING	5					
50	XDA.010.0BG	DADO AUTOBLOCCANTE M10	SELF LOCKING NUT M10	2					
51	XDA.012.0AG	DADO AUTOBLOCCANTE M12	SELF LOCKING NUT M12	22					
52	XDA.024.0AG	DADO AUTOBLOCCANTE M24	SELF LOCKING M24	2					
53	XDO.24.5589G	DADO BASSO M24	LOWER NUT M24	8					
54	XID.006.001	INGRASSATORE DIRITTO M6	GREASER	8					
55	XRP.008.000	RONDELLA PIANA D.8 6592 ZINC.	Ø D. FLAT WASHER	10					

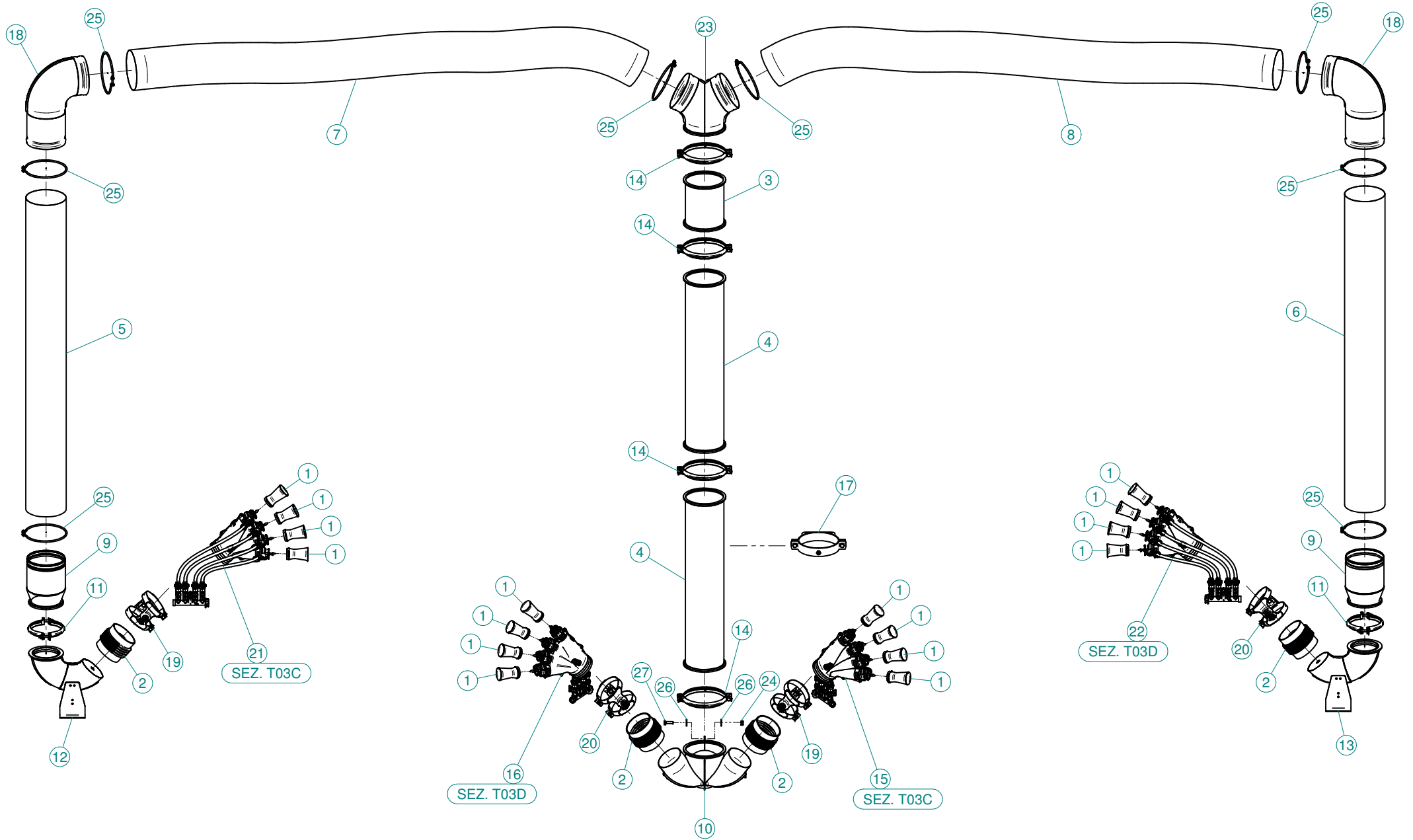

N°	Doc. Number	Titolo	Title	Q.tà
1	X00.010.050	DIFFUSORE 10/50	NOZZLE 10/50	16
2	X02.021.000	MANICOTTO FLESSIBILE D.120X120	120 D. FLEXIBLE SLEEVE	4
3	X02.186.000	PROLUNGA Ø 175 X 210	EXTENSION Ø 175 X 210	1
4	X02.189.000	PROLUNGA Ø175 X 800	EXTENSION Ø175 X 800	2
5	X02.388.150	TUBO SPIRALATO ø180 L=1500	HOSE ø180 L=1500	1
6	X02.388.150	TUBO SPIRALATO ø180 L=1500	HOSE ø180 L=1500	1
7	X02.388.350	TUBO SPIRALATO ø180 L=3500	HOSE ø180 L=3500	1
8	X02.388.350	TUBO SPIRALATO ø180 L=3500	HOSE ø180 L=3500	1
9	X02.749.100	RIDUZIONE DA D.175 A D.130 CON P.G.	RIDUCTION FROM D.175 TO D.130 MIT R.H.	2
10	X02.996.100	CURVA INFERIORE Ø175 CON 2 USCITE Ø120	LOWER BEND	1
11	X04.027.000	COLLARE PER TUBI D. 150	PIPE CLAMP D. 150	2
12	X04.845.300	CURVA A 135° D.120	ELBOW 135° D.120	1
13	X04.845.400	CURVA A 135° D.120	ELBOW 135° D.120	1
14	X05.616.000	COLLARE PER TUBI Ø 175	PIPE CLAMP Ø 175	4
15	X20.014.404CDX	MANO A 4 USCITE COMPLETA DI DISTRIBUTORE	FOUR NOZZLES DIFFUSER	1
16	X20.014.404CSX	MANO A 4 USCITE COMPLETA DI DISTRIBUTORE	FOUR NOZZLES DIFFUSER	1
17	X20.503.000	FASCETTA Ø 175 FISSAGGIO TESTATE	Ø 175 CLAMP HEADS FIXING	1
18	X20.650.100	CURVA D.175 90° CON 2 PORTAGOMMA D.180	ELBOW D.175 90° WITH 2 RUBBER HOLDER D.180	2
19	X21.080.000	COPPIA FASCETTE Ø 127 DESTRA	RIGHT CLAMP Ø 127	2
20	X21.081.000	COPPIA FASCETTE Ø 127 SINISTRA	LEFT CLAMP Ø 127	2
21	X22.014.104CDX	MANO A 4 USCITE COMPLETA DI DISTRIBUTORE	FOUR NOZZLES DIFFUSER	1
22	X22.014.104CSX	MANO A 4 USCITE COMPLETA DI DISTRIBUTORE	FOUR NOZZLES DIFFUSER	1
23	X50.337.000	CORPO Ø175 CON 2 USCITE Ø175	BODY Ø175 WITH 2 OUTLETS Ø175	1
24	XD0.10.5587G	DADO M10 6S PG 5587 ZINC.	M10 6S BIG LEAD NUT 5587	1
25	XF0.180.000	FASCETTA UNIFILO D.180	CLAMP D.180	8
26	XRP.010.030	RONDELLA PIANA F.LARGA D.10X30 ZINC.	10X30mm D. LARGE THREAD FLAT	2
27	XTE.010.035T	VITE TE UNI 5739-65 M10x35-8.8	SCREW TE UNI 5739-65 M10x35-8.8	1

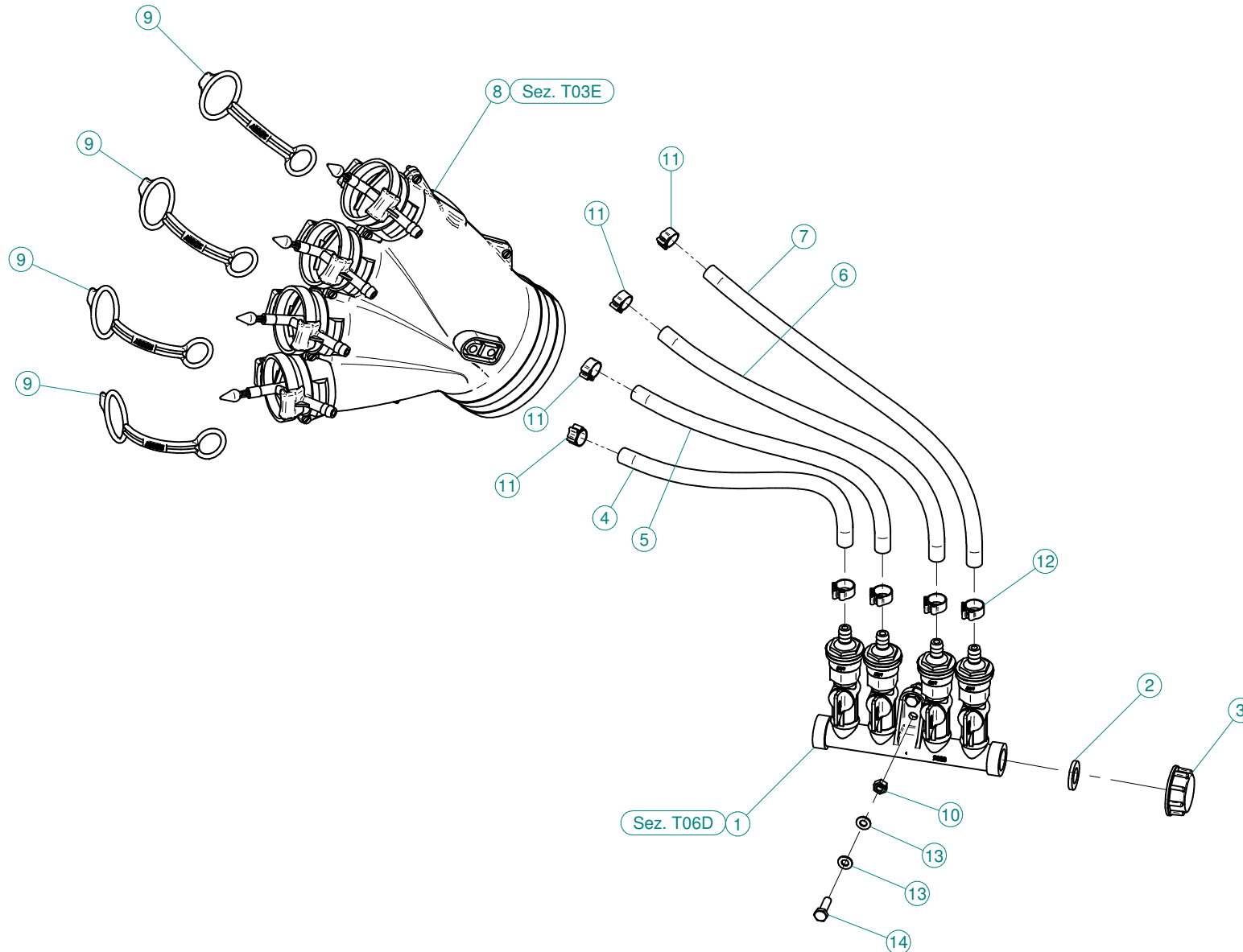

N°	Doc. Number	Titolo	Title	Q.tà
1	X02.008.304C	DISTRIBUTORE LIQUIDI A 4 RUBINETTI CON ANTIGOCCIA	FOUR TAPS LIQUID DISTRIBUTOR WITH ANTI-DRIP DEVICE	1
2	X02.030.010	GUARNIZIONE IN GOMMA D.24X13X3	GASKET D.24X13X3	1
3	X02.182.000	TAPPO 3/4" F.	FEMALE 3/4" CAP	1
4	X02.217.029	TUBO D. 8x13 L=290	HOSE D. 8x13 L=290	1
5	X02.217.033	TUBO D. 8x13 L=330	HOSE D. 8x13 L=330	1
6	X02.217.038	TUBO D. 8x13 L=380	HOSE D. 8x13 L=380	1
7	X02.217.041	TUBO D. 8x13 L=410	HOSE D. 8x13 L=410	1
8	X20.014.000DX	MANO A 4 USCITE CON TUBETTI	FOUR OUTLETS	1
9	X20.697.000	FERMA DIFFUSORI	NOZZLE STOP	4
10	XD0.06.5588G	DADO M6 6S PG 5588 ZINC.	M6 6S BIG LEAD NUT 5588	2
11	XFC.012,5.014	FASCETTA COBRA SL030705	KOBRA CLAMP SL030705	4
12	XFC.013,5.015	FASCETTA COBRA SL030710	KOBRA CLAMP SL030710	4
13	XRP.006.000	RONDELLA PIANA D.6 6592 ZINC.	6mm D. FLAT WASHER	4
14	XTE.006.020T	VITE TE M6X20 5739 ZINC.	BOLT TE M6X20 5739	2

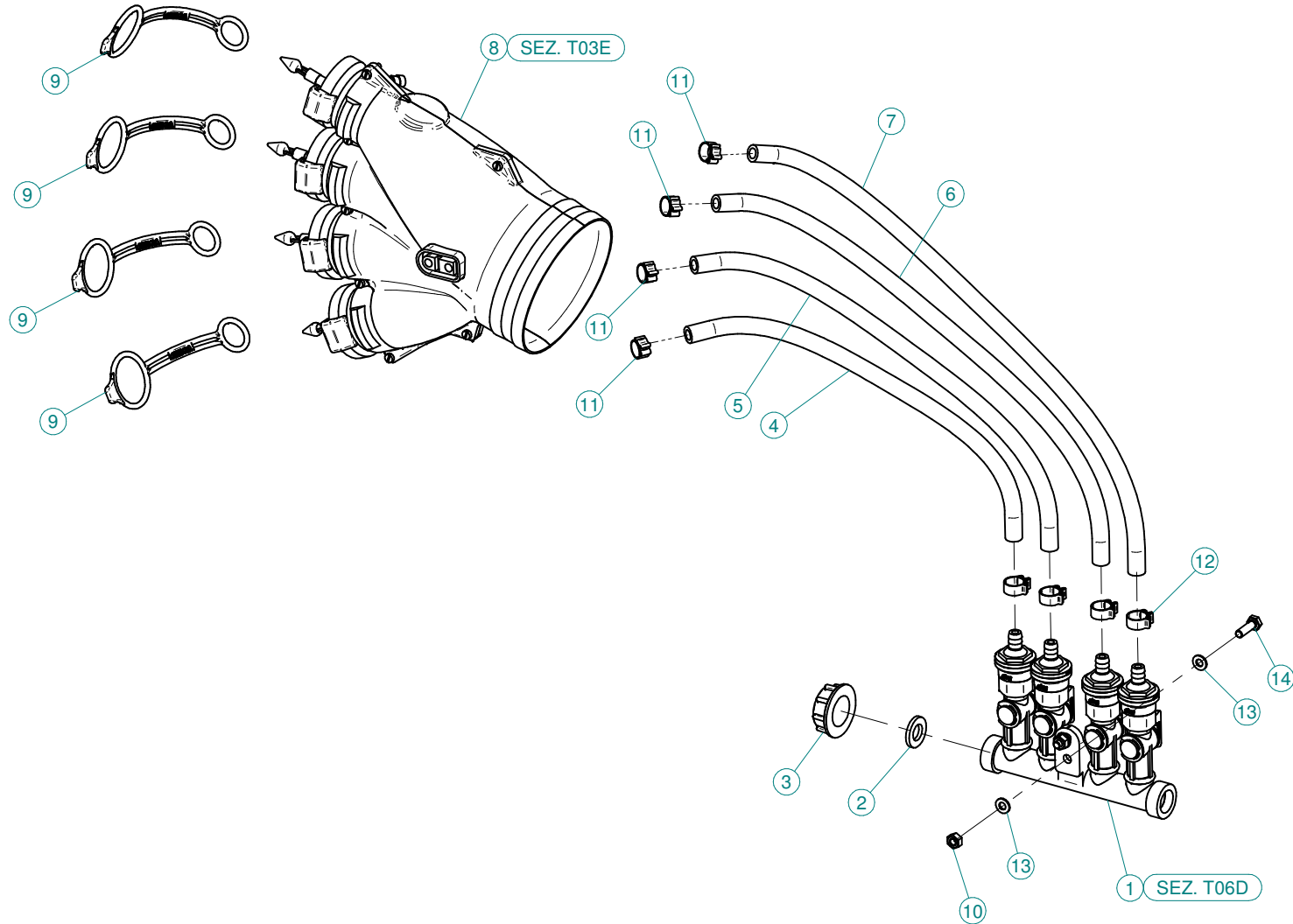

N°	Doc. Number	Titolo	Title	Q.tà
1	X02.008.304C	DISTRIBUTORE LIQUIDI A 4 RUBINETTI CON ANTIGOCCIA	FOUR TAPS LIQUID DISTRIBUTOR WITH ANTI-DRIP DEVICE	1
2	X02.030.010	GUARNIZIONE IN GOMMA D.24X13X3	GASKET D.24X13X3	1
3	X02.182.000	TAPPO 3/4" F.	FEMALE 3/4" CAP	1
4	X02.217.034	TUBO ø8x13 L=340	HOSE ø8x13 L=340	1
5	X02.217.039	TUBO ø8x13 L=390	HOSE ø8x13 L=390	1
6	X02.217.044	TUBO ø8x13 L=440	HOSE ø8x13 L=440	1
7	X02.217.047	TUBO ø8x13 L=470	HOSE ø8x13 L=470	1
8	X20.014.000DX	MANO A 4 USCITE CON TUBETTI	FOUR OUTLETS	1
9	X20.697.000	FERMA DIFFUSORI	NOZZLE STOP	4
10	XD0.06.5588G	DADO M6 6S PG 5588 ZINC.	M6 6S BIG LEAD NUT 5588	2
11	XFC.012,5.014	FASCETTA COBRA SL030705	KOBRA CLAMP SL030705	4
12	XFC.013,5.015	FASCETTA COBRA SL030710	KOBRA CLAMP SL030710	4
13	XRP.006.000	RONDELLA PIANA D.6 6592 ZINC.	6mm D. FLAT WASHER	4
14	XTE.006.020T	VITE TE M6X20 5739 ZINC.	BOLT TE M6X20 5739	2



N°	Doc. Number	Titolo	Title	Q.tà
1	X20.014.001DX	MANO A 4 USCITE NUDA	FOUR OUTLETS	1
2	X20.016.01C	RACCORDO ATTACCO RAPIDO PORTA TUBETTO	PIPE WITH OLIVE	4

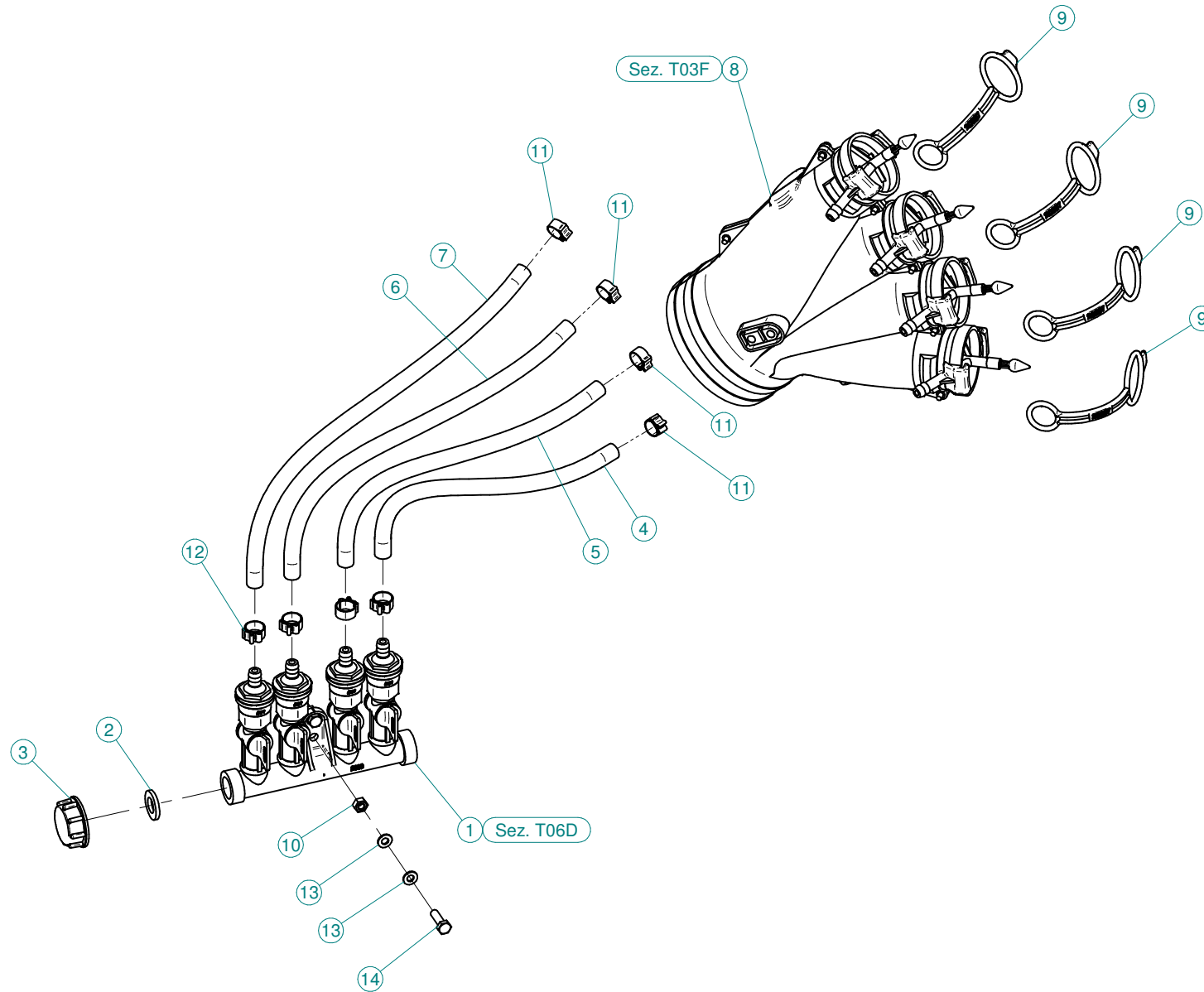

N°	Doc. Number	Titolo	Title	Q.tà
1	X02.008.304C	DISTRIBUTORE LIQUIDI A 4 RUBINETTI CON ANTIGOCCIA	FOUR TAPS LIQUID DISTRIBUTOR WITH ANTI-DRIP DEVICE	1
2	X02.030.010	GUARNIZIONE IN GOMMA D.24X13X3	GASKET D.24X13X3	1
3	X02.182.000	TAPPO 3/4" F.	FEMALE 3/4" CAP	1
4	X02.217.029	TUBO D. 8x13 L=290	HOSE D. 8x13 L=290	1
5	X02.217.033	TUBO D. 8x13 L=330	HOSE D. 8x13 L=330	1
6	X02.217.038	TUBO D. 8x13 L=380	HOSE D. 8x13 L=380	1
7	X02.217.041	TUBO D. 8x13 L=410	HOSE D. 8x13 L=410	1
8	X20.014.000SX	MANO A 4 USCITE CON TUBETTI	FOUR OUTLETS	1
9	X20.697.000	FERMA DIFFUSORI	NOZZLE STOP	4
10	XD0.06.5588G	DADO M6 6S PG 5588 ZINC.	M6 6S BIG LEAD NUT 5588	2
11	XFC.012,5.014	FASCETTA COBRA SL030705	KOBRA CLAMP SL030705	4
12	XFC.013,5.015	FASCETTA COBRA SL030710	KOBRA CLAMP SL030710	4
13	XRP.006.000	RONDELLA PIANA D.6 6592 ZINC.	6mm D. FLAT WASHER	4
14	XTE.006.020T	VITE TE M6X20 5739 ZINC.	BOLT TE M6X20 5739	2

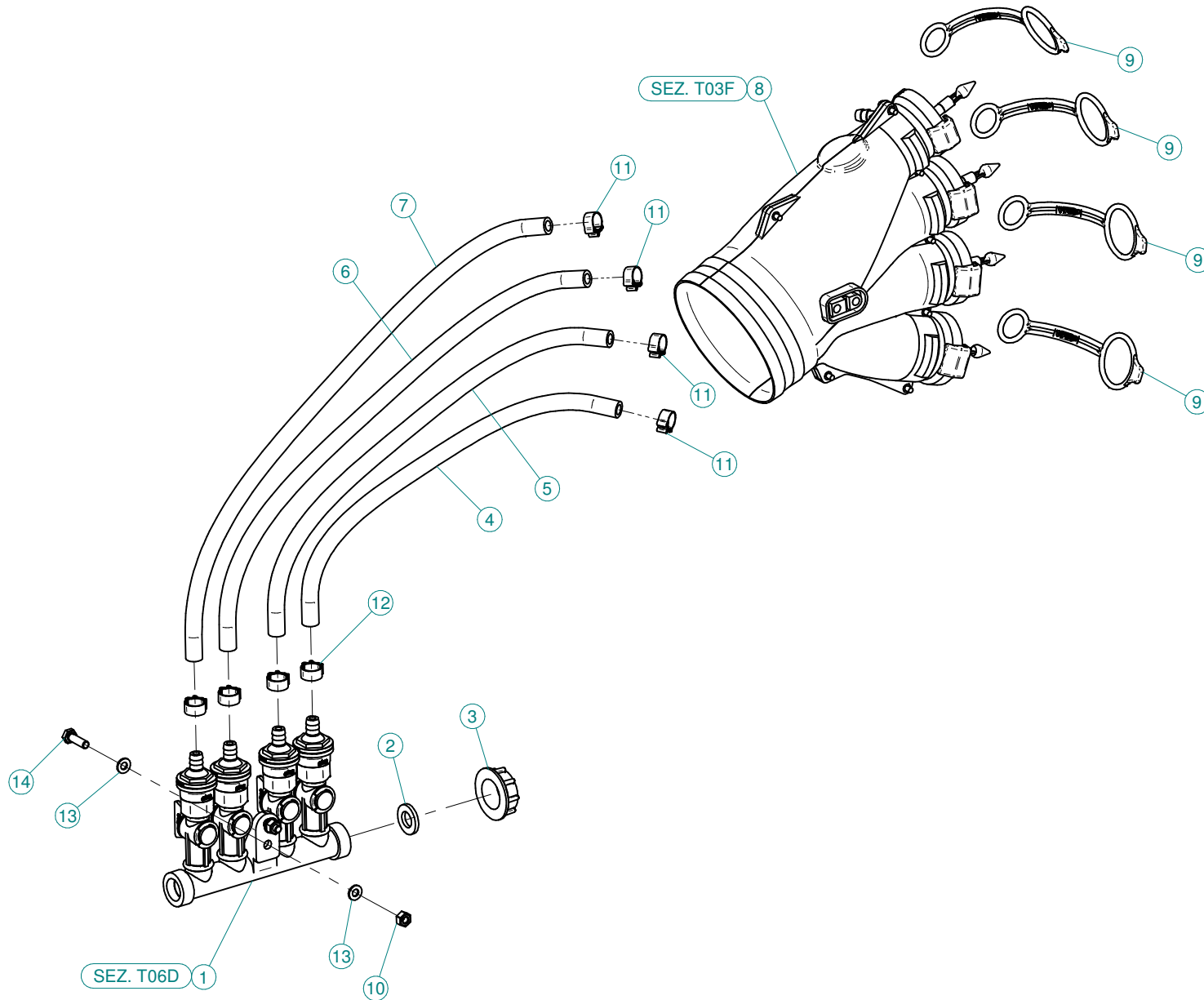

N°	Doc. Number	Titolo	Title	Q.tà
1	X02.008.304C	DISTRIBUTORE LIQUIDI A 4 RUBINETTI CON ANTIGOCCIA	FOUR TAPS LIQUID DISTRIBUTOR WITH ANTI-DRIP DEVICE	1
2	X02.030.010	GUARNIZIONE IN GOMMA D.24X13X3	GASKET D.24X13X3	1
3	X02.182.000	TAPPO 3/4" F.	FEMALE 3/4" CAP	1
4	X02.217.034	TUBO ø8x13 L=340	HOSE ø8x13 L=340	1
5	X02.217.039	TUBO ø8x13 L=390	HOSE ø8x13 L=390	1
6	X02.217.044	TUBO ø8x13 L=440	HOSE ø8x13 L=440	1
7	X02.217.047	TUBO ø8x13 L=470	HOSE ø8x13 L=470	1
8	X20.014.000SX	MANO A 4 USCITE CON TUBETTI	FOUR OUTLETS	1
9	X20.697.000	FERMA DIFFUSORI	NOZZLE STOP	4
10	XD0.06.5588G	DADO M6 6S PG 5588 ZINC.	M6 6S BIG LEAD NUT 5588	2
11	XFC.012,5.014	FASCETTA COBRA SL030705	KOBRA CLAMP SL030705	4
12	XFC.013,5.015	FASCETTA COBRA SL030710	KOBRA CLAMP SL030710	4
13	XRP.006.000	RONDELLA PIANA D.6 6592 ZINC.	6mm D. FLAT WASHER	4
14	XTE.006.020T	VITE TE M6X20 5739 ZINC.	BOLT TE M6X20 5739	2

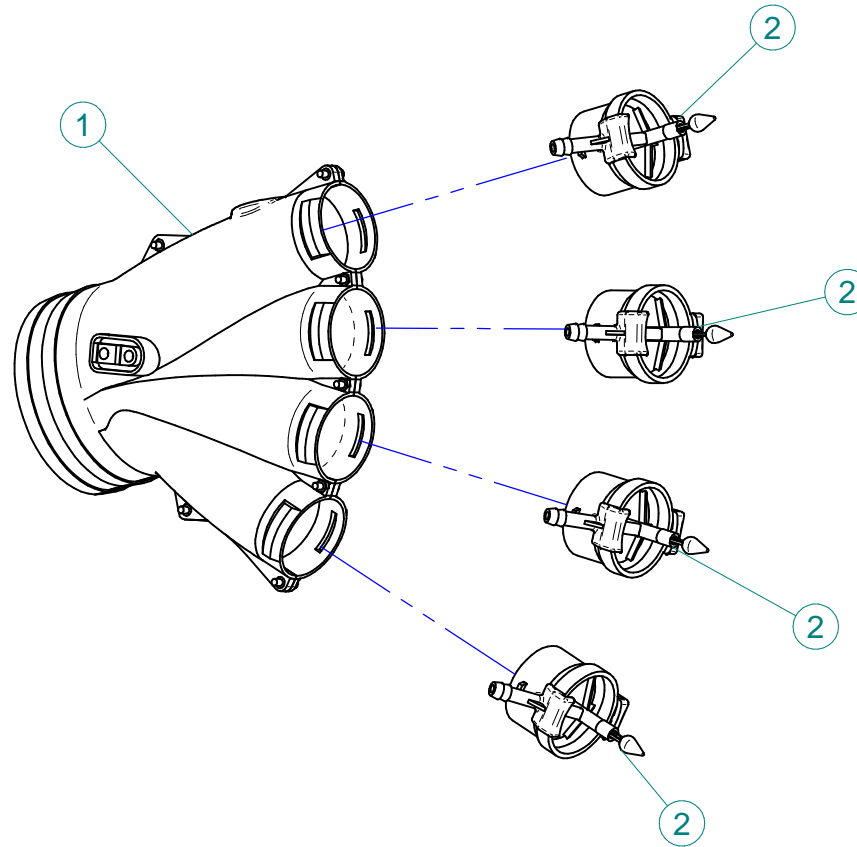

N°	Doc. Number	Titolo	Title	Q.tà
1	X20.014.001DX	MANO A 4 USCITE NUDA	FOUR OUTLETS	1
2	X20.016.01C	RACCORDO ATTACCO RAPIDO PORTA TUBETTO	PIPE WITH OLIVE	4

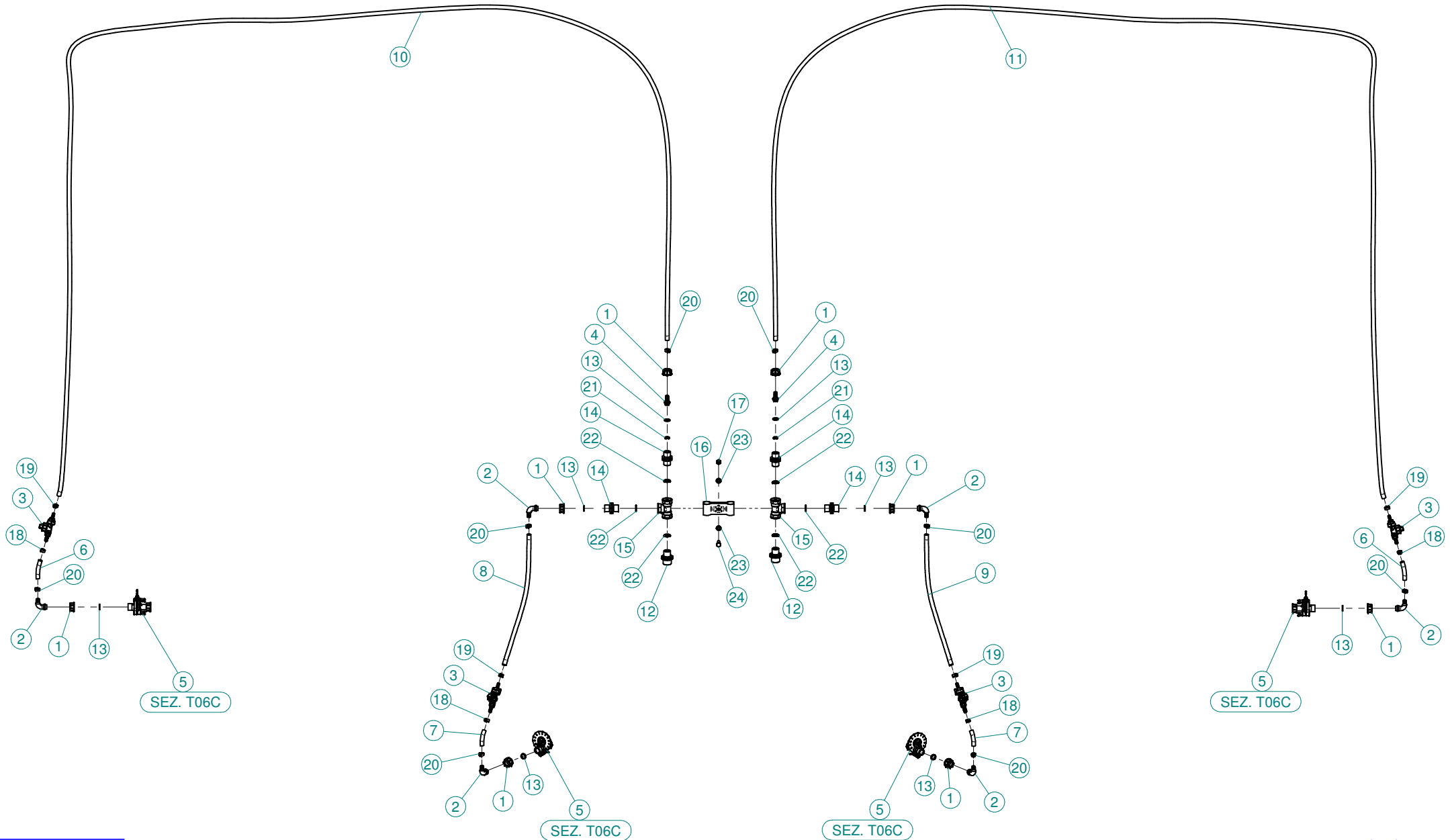

N°	Doc. Number	Titolo	Title	Q.tà
1	X00.055.045	GIRELLO 3/4" GAS ALTO	3/4" GAS FLY NUT	8
2	X00.055.046R	RACCORDO CURVO P.G. Ø 14	CURVED UNION WITH R.H. D.14	6
3	X00.226.05C	GETTO ANTIGOCCIA DIRITTO COMPLETO (0,3 bar)	COMPLETE ANTIDROP (0,3 bar)	4
4	X02.122.000	RACCORDO A P.G. Ø 13	Ø 13 UNION	2
5	X02.150.000	REGOLATORE A DISCO ROTANTE COMPLETO	ROTATION DISK REGULATION	4
6	X02.213.007	TUBO Ø10x16 L=70	HOSE Ø10x16 L=70	2
7	X02.213.007	TUBO Ø10x16 L=70	HOSE Ø10x16 L=70	2
8	X02.213.060	TUBO Ø10x16 L=600	HOSE Ø10x16 L=600	1
9	X02.213.060	TUBO Ø10x16 L=600	HOSE Ø10x16 L=600	1
10	X02.213.600	TUBO Ø10x16 L=6000	HOSE Ø10x16 L=6000	1
11	X02.213.600	TUBO Ø10x16 L=6000	HOSE Ø10x16 L=6000	1
12	X02.293.000	RIDUZIONE 1" M - 3/4" M	1" M - 3/4" M REDUCER NIPPLE	2
13	X02.349.000	GUARNIZIONE PIANA D.17X23X3	17X23X3 FLAT GASKET (G4000B)	8
14	X02.380.000	NIPPLO 3/4"	NIPPLE 3/4"	4
15	X02.396.000	RACCORDO A T 3/4" - 3/4" - 3/4" F.	UNION 3/4" - 3/4" - 3/4" F.	2
16	X02.999.000	STAFFA FISSAGGIO RACCORDO A T	T UNION FIXING BRACKET	1
17	XDA.010.0BG	DADO AUTOBLOCCANTE M10	SELF LOCKING NUT M10	1
18	XFC.013,5.015	FASCETTA COBRA SL030710	KOBRA CLAMP SL030710	4
19	XFC.015,5.017	FASCETTA COBRA SLO30720	KOBRA CLAMP	4
20	XFC.016,5.018	FASCETTA COBRA 16,5 - 18	KOBRA CLAMP 16,5 - 18	8
21	XOR.000.117	OR D.13,1X2,62	13.1X2.62 O-RING GASKET	2
22	XOR.004.081	OR Ø 20,22 x 3,53	20,22 x 3,53 O-RING GASKET	6
23	XRP.010.000	RONDELLA PIANA D.10 6592 ZINC.	WASHER Ø 10	2
24	XTE.010.035T	VITE TE UNI 5739-65 M10x35-8.8	SCREW TE UNI 5739-65 M10x35-8.8	1

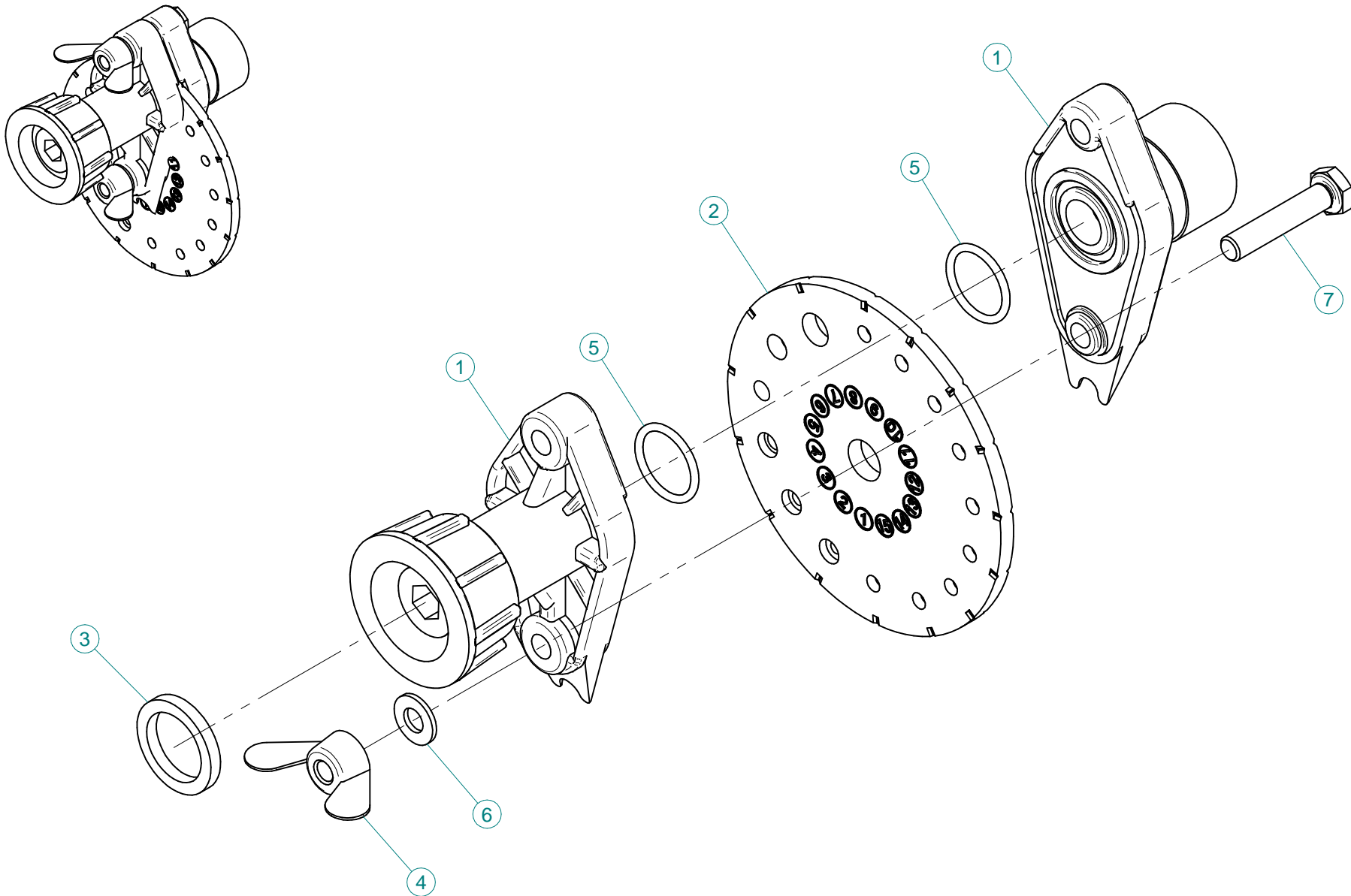

N°	Doc. Number	Titolo	Title	Q.tà
1	X02.147.500	COPPIA DI SEMICORPO REGOLATORE	REGULATOR HALF-BODY	1
2	X02.148.000	DISCO ROTANTE PER REGOLATORE	REGULATOR DISK	1
3	X02.349.000	GUARNIZIONE PIANA D.17X23X3	17X23X3 FLAT GASKET (G4000B)	1
4	XDF.OTT.006	DADO AD ALETTE IN OTTONE M6	BRASS M6 WING NUT	2
5	XOR.002.062	OR D.15,6X1,78	15.6X1.78 O-RING GASKET	2
6	XRP.006.00I	RONDELLA PIANA D.6 INOX	WASHER D.6	2
7	XTE.006.030I	VITE TE M6X30 INOX 5739	BOLT TE M6X30 STAINLESS STEEL 5739	2



N°	Doc. Number	Titolo	Title	Q.tà
1	X00.227.01C	DISPOSITIVO ANTIGOCCIA	ANTI DRIP DEVICE	4
2	X02.008.000	DISTRIBUTORE LIQUIDO TESTATE	SPRAYHEADS LIQUID DISTRIBUTOR	1
3	X20.202.100	RUBINETTO F.1/4" M.18X1,5	TAP ASSEMBLY	4
4	XOR.000.117	OR D.13,1X2,62	13.1X2.62 O-RING GASKET	4

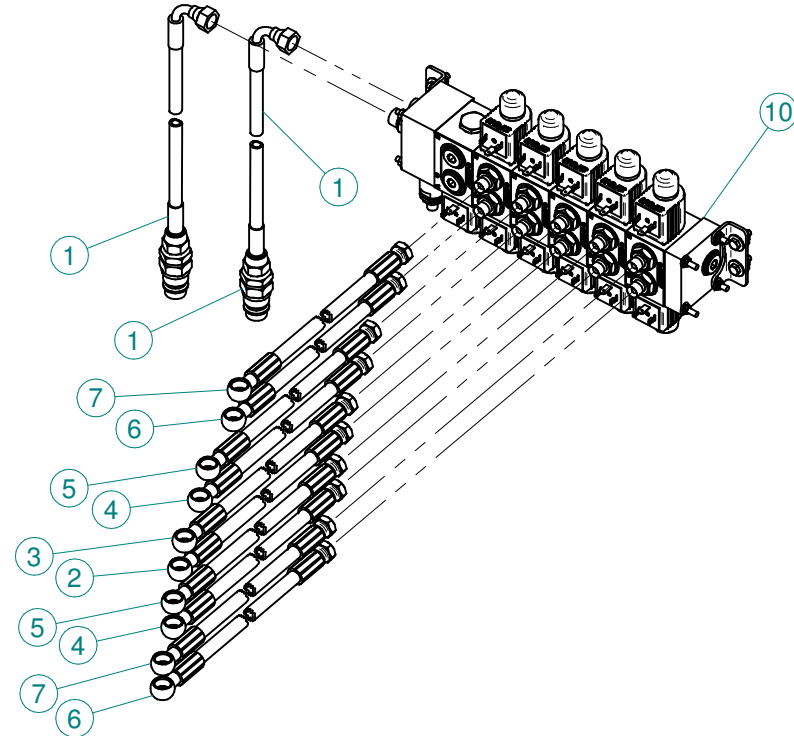
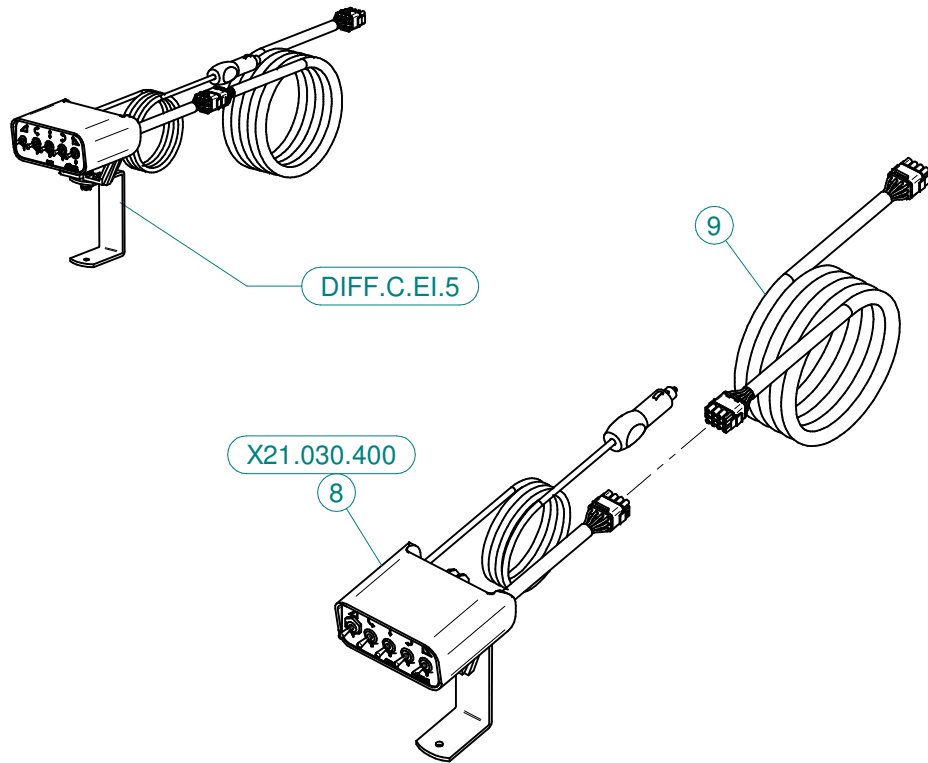

N°	Doc. Number	Titolo	Title	Q.tà
1	X20.900.370	TUBO OLIO PER MARTINETTO L=3700	OIL PIPE FOR JACK L=3700	2
2	X20.961.050	TUBO OLIO PER MARTINETTO L=500	OIL PIPE FOR JACK L=500	1
3	X20.961.100	TUBO OLIO PER MARTINETTO L=1000	OIL PIPE FOR JACK L=1000	1
4	X20.961.130	TUBO OLIO PER MARTINETTO L=1300	OIL PIPE FOR JACK L=1300	2
5	X20.961.140	TUBO OLIO PER MARTINETTO L=1400	OIL PIPE FOR JACK L=1400	2
6	X20.961.150	TUBO OLIO PER MARTINETTO L=1500	OIL PIPE FOR JACK L=1500	2
7	X20.961.160	TUBO OLIO PER MARTINETTO L=1600	OIL PIPE FOR JACK L=1600	2
8	X21.030.400	KIT COMANDO ELETTROIDRAULICO A 5 VIE	KIT FOR CONTROL SOLENOID VALVE	1
9	X21.055.000	CAVO PROLUNGA Mt.3 ML12 M/F	EXTENSION CABLE Mt. 3 ML12 M/F	1
10	X21.057.000	BLOCCO ELETTROVALVOLE componibili	COMPONIBLE DIRECTIONAL VALVES	1

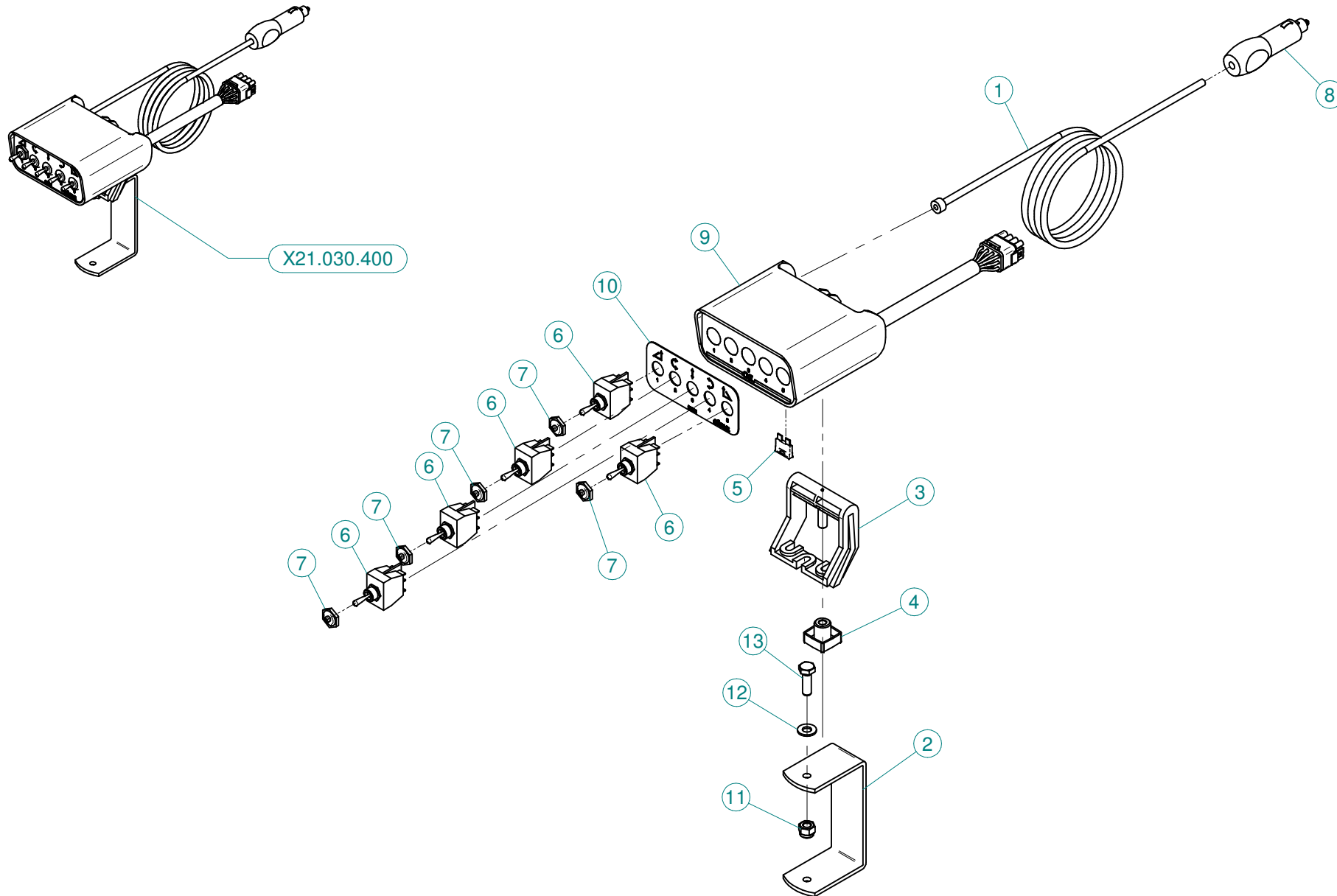

N°	Doc. Number	Titolo	Title	Q.tà
1	X02.401.182	CAVO DI ALIMENTAZIONE D.1x 2 L=1820	POWER CABLE D.1 x 2 L=1820	1
2	X20.110.000	STAFFA SUPPORTO DOPPIO PER BAIONETTA	BRACKET SUPPORT DOUBLE FOR BAYONET	1
3	X21.030.002	STAFFA DI FISSAGGIO MOBILE	MOVING FIXING BRACKET	1
4	X21.030.003	POMELLO DI BLOCCAGGIO	FIXING KNOB	1
5	X21.030.004	FUSIBILE - 10 Ah	10 Ah FUSE	1
6	X21.030.006	DEVIATORE MOM - 0 - MOM 10A	SWITCH MOM - 0 - MOM 10A	5
7	X21.030.007	CAPPUCCIO INTERRUTTORE D.12	SWITCH CAP D.12	5
8	X21.030.008	CONNETTORE DI ALIMENTAZIONE 12V	12V POWER JACK	1
9	X21.056.001	SCATOLA DI COMANDO (NON FORNITO)	SWITCH BOX (NOT SUPPLIED)	1
10	X96.061.000	ADESIVO SCATOLA COMANDO OLIO	ADHESIVE BOX	1
11	XDA.008.0AG	DADO AUTOBLOCCANTE M8 ALTO PG ZINC.	HIGH BIG LEAD M8 SELFLOCKING	1
12	XRP.008.000	RONDELLA PIANA D.8 6592 ZINC.	8 D. FLAT WASHER	1
13	XTE.008.025T	VITE TE M8X25	BOLT TE M8X25	1

Gli esplosi elencati di seguito sono relativi
a varianti o accessori a richiesta

The exploded drawings listed below are related
to different versions or optional accessories

Le vues éclatées suivantes sont relatives
à des variantes ou à des accessoires optionnels

Dibujos de vista despiezada son relativos a
variantes o accesorios opcionales



Ø 175
 Plus 42 - 45 - 50
 Blitz 45 - 50
 Link 50



Ø 250
 Plus 55
 Blitz 55
 Link 55