

Sez. T25 (⌘)
Movimentazione Elettrica
Electrical Movement

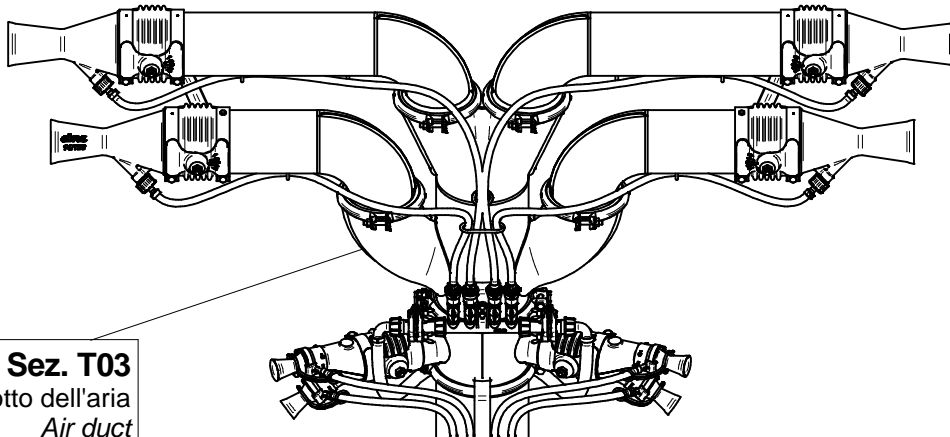

Sez. T03
Condotto dell'aria
Air duct

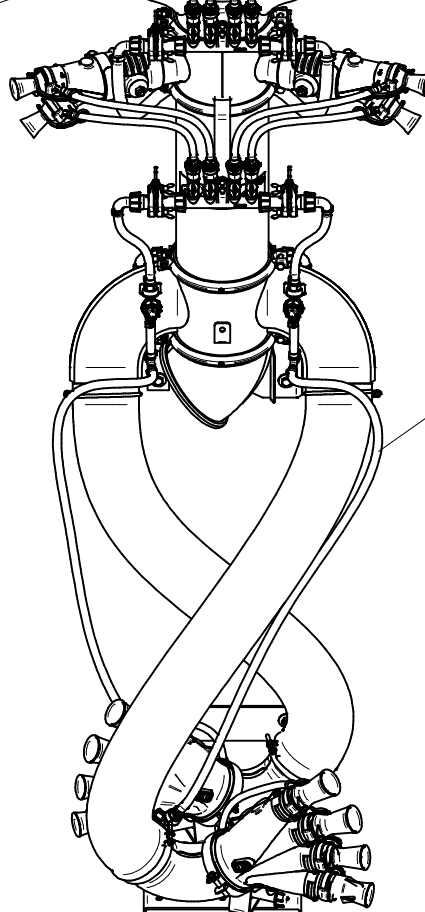

Sez. T06
Circuito idraulico
Plumbing of liquids

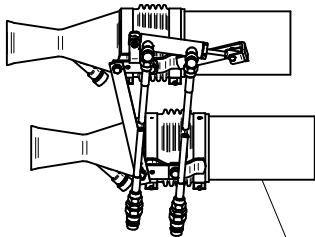

Sez. T24 (⌘)
Movimentazione Idraulica
Hydraulic Movement

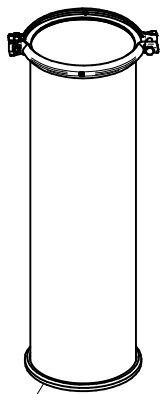

Sez. T28 (⌘)
Prolunghe
Extension

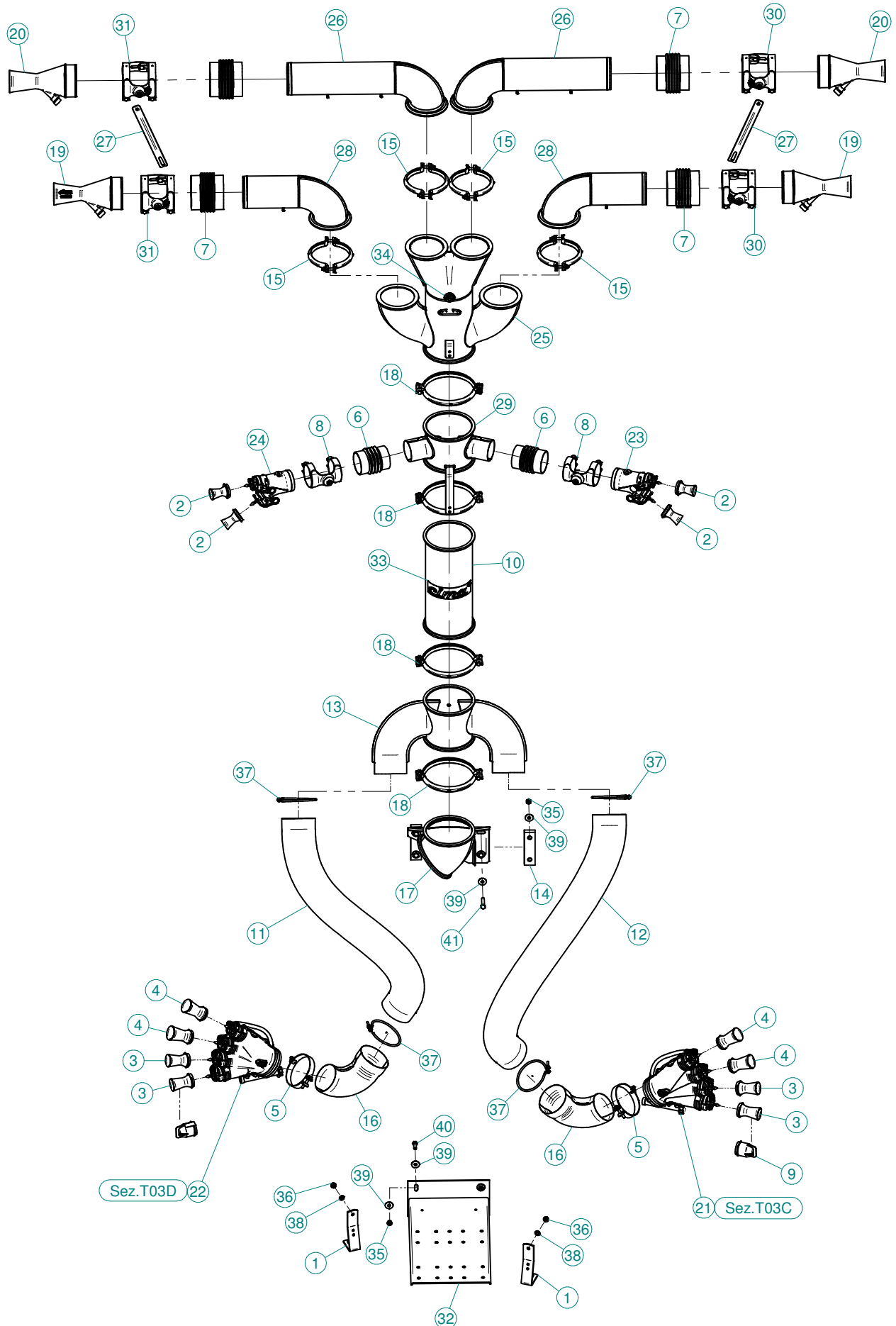

N°	Doc. Number	Titolo	Title	Q.tà
1	X20.283.100	SQUADRETTA FISSAGGIO MANI	OUTLET'S JOINT PLATE	2
2	X00.003,5.50	DIFFUSORE 3,5/50	NOZZLE 3,5/50	4
3	X00.006.050	DIFFUSORE 6/50	NOZZLE 6/50	4
4	X00.008.050	DIFFUSORE 8/50	NOZZLE 8/50	4
5	X00.125.001	FEMMINA FASCETTA D.125 ORIENTABILE	FEMALE CLAMP D.125	2
6	X02.020.000	MANICOTTO FLESSIBILE Ø 80 x 115	FLEXIBLE SLEEVE Ø 80 x 115	2
7	X02.021.000	MANICOTTO FLESSIBILE D.120X120	120 D. FLEXIBLE SLEEVE	4
8	X02.046.000	COPPIA FASCETTE Ø 85	CLAMP Ø 85	2
9	X02.127.000	TAPPO DI ATTACCO RAPIDO	CAP NOZZLE PLUG	2
10	X02.187.000	PROLUNGA Ø 175 X 400	EXTENSION D.175 X 400	1
11	X02.239.100	TUBO TANEGUM Ø120 L=940	TANEGUM HOSE Ø120 L=940	1
12	X02.239.100	TUBO TANEGUM Ø120 L=1040	TANEGUM HOSE Ø120 L=1040	1
13	X02.866.400	CORPO A 2 USCITE Ø120 PER BLITZ "A"	BODY 2 USCITE Ø120 PER BLITZ "A"	1
14	X02.992.000	STAFFA FISSAGGIO CURVE	BRACKET	2
15	X04.027.000	COLLARE PER TUBI D. 150	PIPE CLAMP D. 150	4
16	X04.845.000	CURVA D.120 A 105°	ELBOW D.120 A 105°	2
17	X04.877.000	CURVA A 45° Ø175	45° BEND Ø175	1
18	X05.616.000	COLLARE PER TUBI Ø 175	PIPE CLAMP Ø 175	4
19	X10.014.120	DIFFUSORE 14/120	CANNON 14/120	2
20	X10.018.120	DIFFUSORE 18/120 CON TUBETTO	NOZZLE 18/120	2
21	X20.014.804CDX	MANO A 4 USCITE COMPLETA DI DISTRIBUTORE	FOUR NOZZLES DIFFUSER	1
22	X20.014.804CSX	MANO A 4 USCITE COMPLETA DI DISTRIBUTORE	FOUR NOZZLES DIFFUSER	1
23	X20.221.100DX	MANO Ø 80 A DUE USCITE	TWO OUTLETS BODY	1
24	X20.221.100SX	MANO Ø 80 A DUE USCITE	TWO OUTLETS BODY	1
25	X20.644.100	CORPO TESTATA D.175 CON 4 USCITE D.130 IN FERRO	SPRAYHEAD BODY D.175 WITH 4 OUTLETS D.130	1
26	X20.644.102	CURVA D.120 L=520 PER TC	ELBOW D.120 L=520 PER TC	2
27	X20.666.000	STAFFA COLLEGAMENTO DIFFUSORI	NOZZLES UNION BRACKET	2
28	X20.675.000	CURVA D.120 L=330 PER TC	ELBOW D.120 L=330 PER TC	2
29	X20.890.300	TRONCHETTO Ø 175 L=150 CON 2 USCITE Ø 80	EXTENSION Ø 175 L=150 WITH 2 OUTLETS Ø 80	1
30	X21.080.000	COPPIA FASCETTE Ø 127 DESTRA	RIGHT CLAMP Ø 127	2
31	X21.081.000	COPPIA FASCETTE Ø 127 SINISTRA	LEFT CLAMP Ø 127	2
32	X50.282.001	STAFFA FISSAGGIO CURVE 90° SU LINK E PLUS 50 e 55	BRACKET	1
33	X96.118.000	ADESIVO - CIMA 100x200	DECALS - CIMA 100x200	1
34	X96.158.000	ADESIVO 50 PER TESTATE	DECALS 50 FOR HEADS	1
35	XD0.10.5587G	DADO M10 6S PG 5587 ZINC.	M10 6S BIG LEAD NUT 5587	8
36	XDA.010.0BG	DADO AUTOBLOCCANTE M10	SELF LOCKING NUT M10	4
37	XF0.120.000	FASCETTA UNIFILO D.120	CLAMP D.120	4
38	XRP.010.000	RONDELLA PIANA D.10 6592 ZINC.	WASHER Ø 10	4
39	XRP.010.030	RONDELLA PIANA F.LARGA D.10X30 ZINC.	10X30mm D. LARGE THREAD FLAT	16
40	XTE.010.030T	VITE TE UNI 5739-65 M10x30-8.8	SCREW TE UNI 5739-65 M10x30-8.8	4
41	XTE.010.050T	VITE TE M10X50 5739 ZINC.	BOLT TE M10X50 5739	4

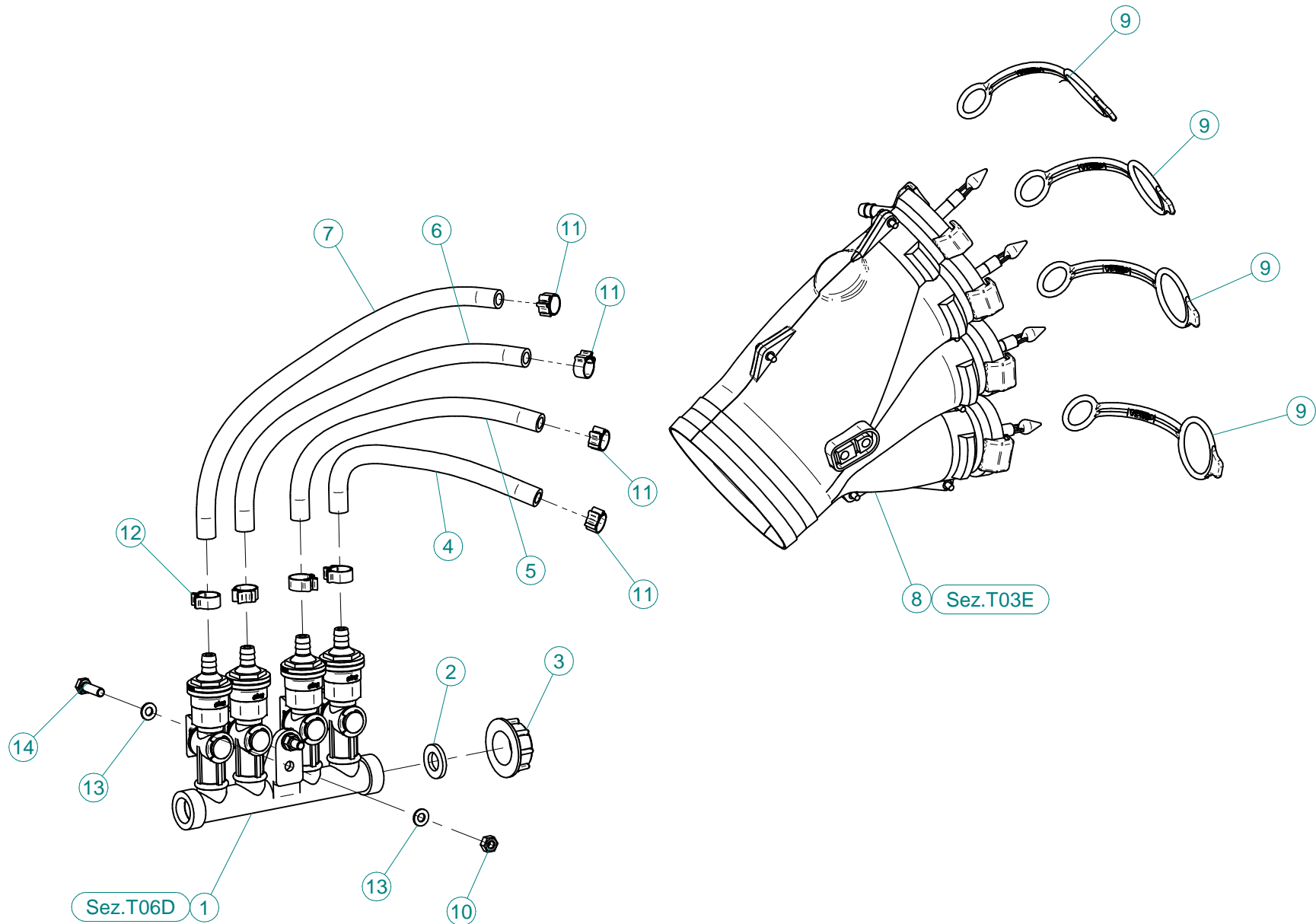

N°	Doc. Number	Titolo	Title	Q.tà
1	X02.008.304C	DISTRIBUTORE LIQUIDI A 4 RUBINETTI CON ANTIGOCCIA	FOUR TAPS LIQUID DISTRIBUTOR WITH ANTI-DRIP DEVICE	1
2	X02.030.010	GUARNIZIONE IN GOMMA D.24X13X3	GASKET D.24X13X3	1
3	X02.182.000	TAPPO 3/4" F.	FEMALE 3/4" CAP	1
4	X02.217.018	TUBO D. 8x13 L=180	HOSE D. 8x13 L=180	1
5	X02.217.022	TUBO D. 8x13 L=220	HOSE D. 8x13 L=220	1
6	X02.217.026	TUBO D. 8x13 L=260	HOSE D. 8x13 L=260	1
7	X02.217.029	TUBO D. 8x13 L=290	HOSE D. 8x13 L=290	1
8	X20.014.000DX	MANO A 4 USCITE CON TUBETTI	FOUR OUTLETS	1
9	X20.697.000	FERMA DIFFUSORI	NOZZLE STOP	4
10	XD0.06.5588G	DADO M6 6S PG 5588 ZINC.	M6 6S BIG LEAD NUT 5588	2
11	XFC.012,5.014	FASCETTA COBRA SL030705	KOBRA CLAMP SL030705	4
12	XFC.013,5.015	FASCETTA COBRA SL030710	KOBRA CLAMP SL030710	4
13	XRP.006.000	RONDELLA PIANA D.6 6592 ZINC.	6mm D. FLAT WASHER	4
14	XTE.006.020T	VITE TE M6X20 5739 ZINC.	BOLT TE M6X20 5739	2

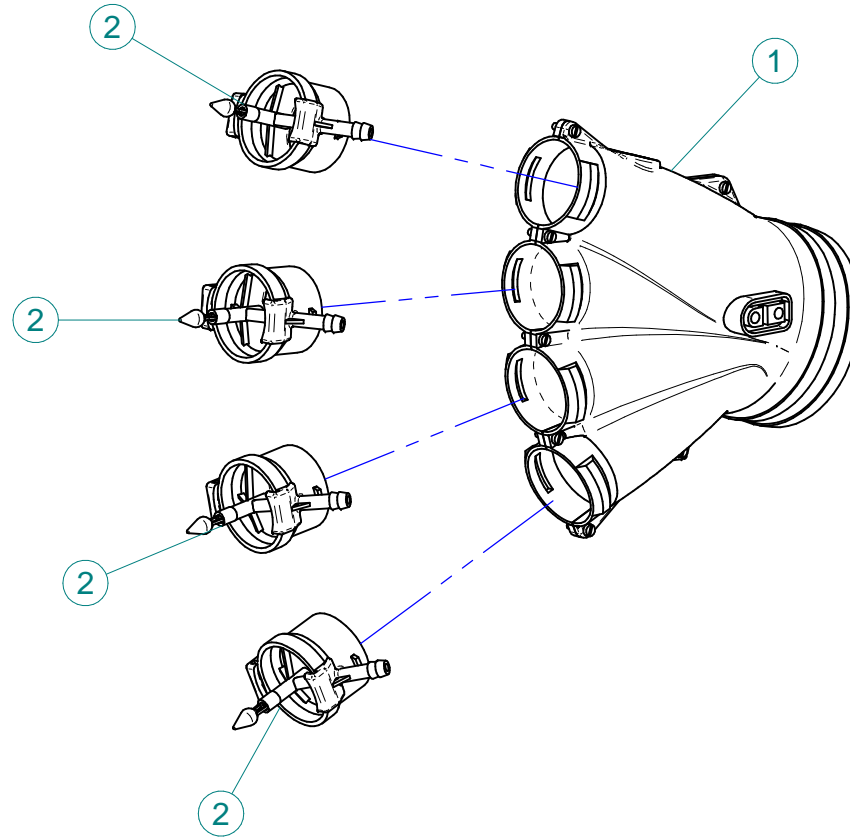

N°	Doc. Number	Titolo	Title	Q.tà
1	X20.014.001DX	MANO A 4 USCITE NUDA	FOUR OUTLETS	1
2	X20.016.01C	RACCORDO ATTACCO RAPIDO PORTA TUBETTO	PIPE WITH OLIVE	4

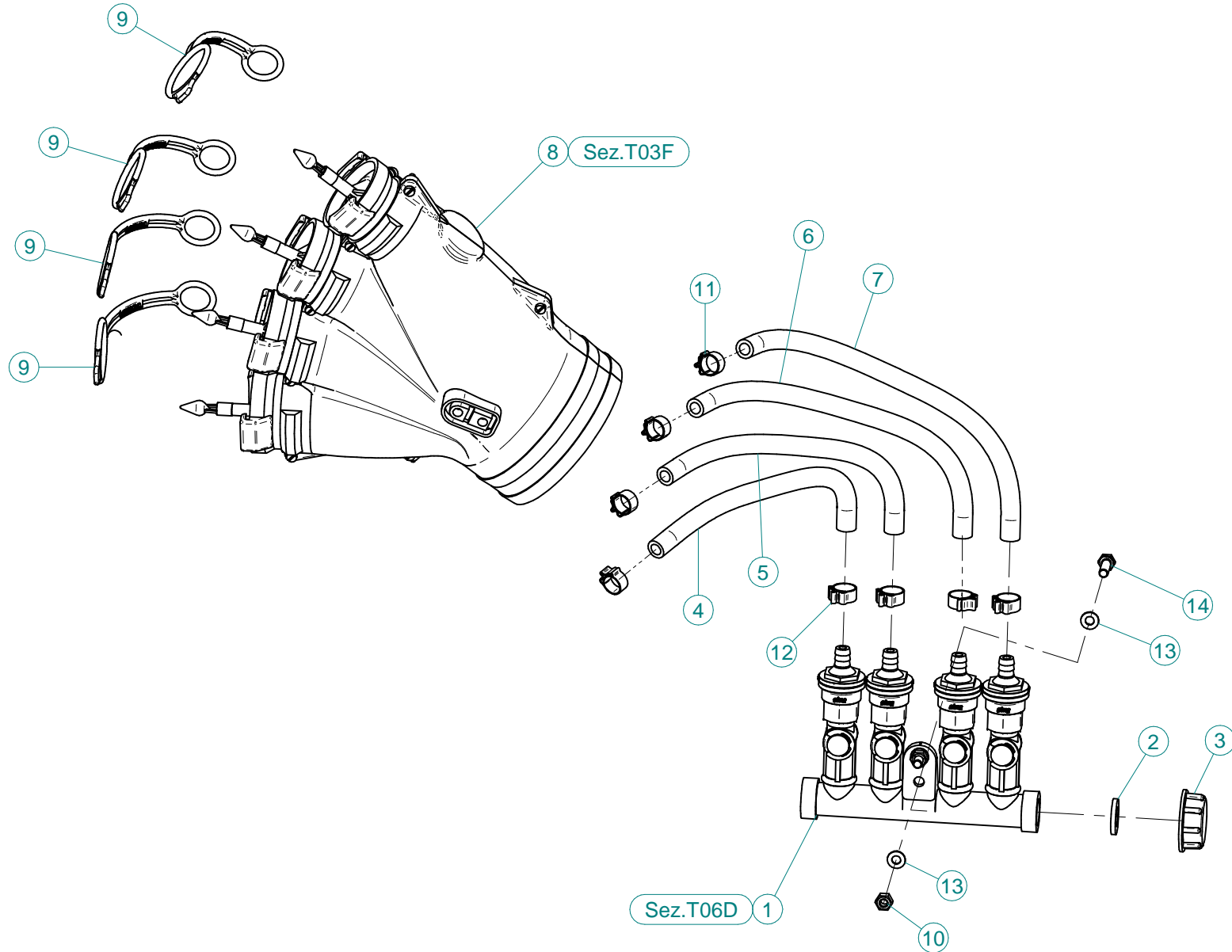

N°	Doc. Number	Titolo	Title	Q.tà
1	X02.008.304C	DISTRIBUTORE LIQUIDI A 4 RUBINETTI CON ANTIGOCCIA	FOUR TAPS LIQUID DISTRIBUTOR WITH ANTI-DRIP DEVICE	1
2	X02.030.010	GUARNIZIONE IN GOMMA D.24X13X3	GASKET D.24X13X3	1
3	X02.182.000	TAPPO 3/4" F.	FEMALE 3/4" CAP	1
4	X02.217.018	TUBO D.8x13 L=180	HOSE D. 8x13 L=180	1
5	X02.217.022	TUBO D. 8x13 L=220	HOSE D. 8x13 L=220	1
6	X02.217.026	TUBO D. 8x13 L=260	HOSE D. 8x13 L=260	1
7	X02.217.029	TUBO D. 8x13 L=290	HOSE D. 8x13 L=290	1
8	X20.014.000SX	MANO A 4 USCITE CON TUBETTI	FOUR OUTLETS	1
9	X20.697.000	FERMA DIFFUSORI	NOZZLE STOP	4
10	XD0.06.5588G	DADO M6 6S PG 5588 ZINC.	M6 6S BIG LEAD NUT 5588	2
11	XFC.012,5.014	FASCETTA COBRA SL030705	KOBRA CLAMP SL030705	4
12	XFC.013,5.015	FASCETTA COBRA SL030710	KOBRA CLAMP SL030710	4
13	XRP.006.000	RONDELLA PIANA D.6 6592 ZINC.	6mm D. FLAT WASHER	4
14	XTE.006.020T	VITE TE M6X20 5739 ZINC.	BOLT TE M6X20 5739	2



N°	Doc. Number	Titolo	Title	Q.tà
1	X20.014.001DX	MANO A 4 USCITE NUDA	FOUR OUTLETS	1
2	X20.016.01C	RACCORDO ATTACCO RAPIDO PORTA TUBETTO	PIPE WITH OLIVE	4

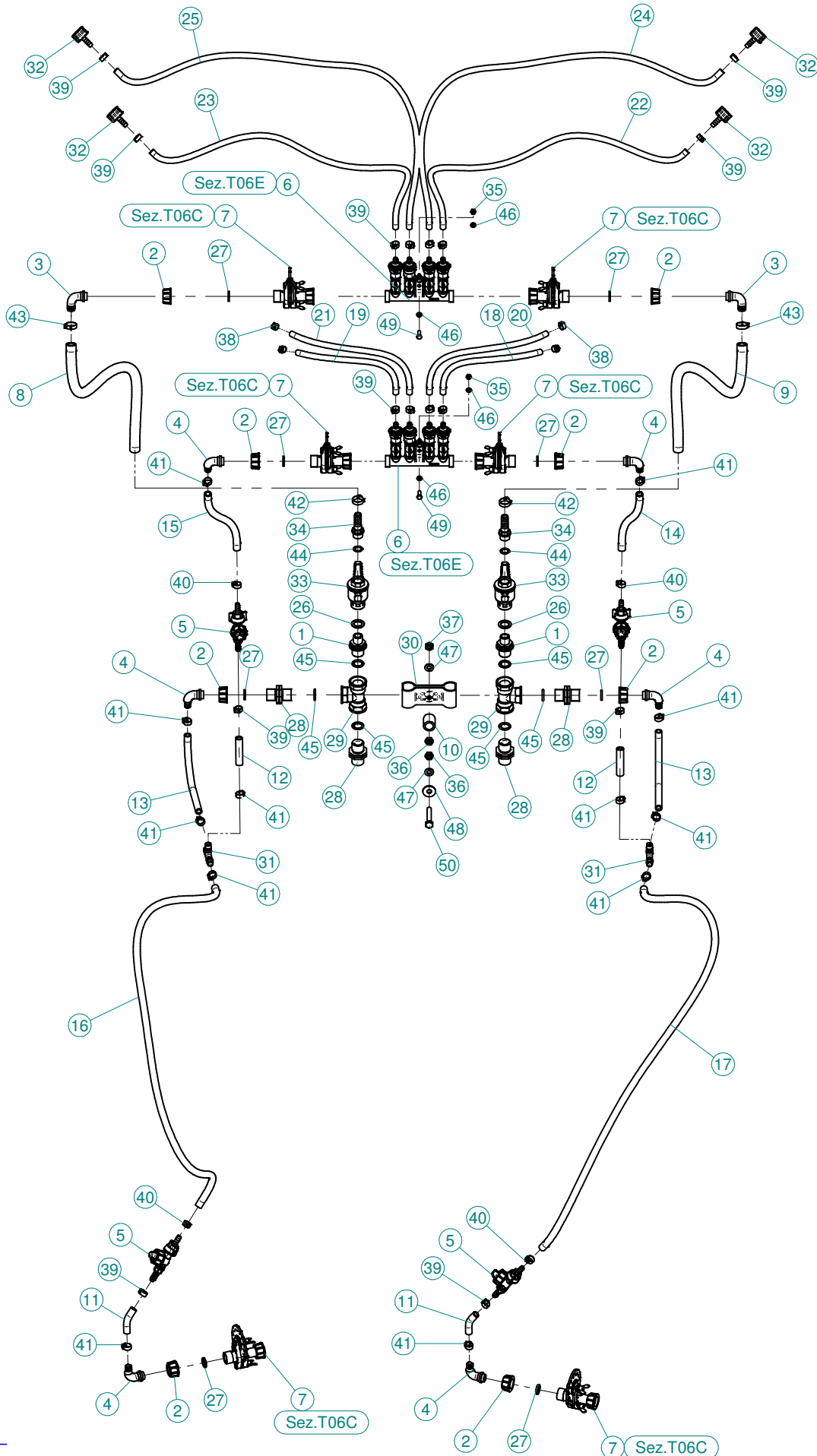

N°	Doc. Number	Titolo	Title	Q.tà
1	X00.055.044	NIPPLO 1/2" GAS 3/4" GAS	NIPPLE 1/2" - 3/4" GAS	2
2	X00.055.045	GIRELLO 3/4" GAS ALTO	3/4" GAS FLY NUT	8
3	X00.055.046	RACCORDO CURVO P.G. Ø16	CURVED UNION WITH R.H. Ø16	2
4	X00.055.046R	RACCORDO CURVO P.G. Ø 14	CURVED UNION WITH R.H. D.14	6
5	X00.226.05C	GETTO ANTIGOCCIA DIRITTO COMPLETO (0,3 bar)	COMPLETE ANTIDROP (0,3 bar)	4
6	X02.008.404C	DISTRIBUTORE LIQUIDI A 4 RUBINETTI	4 TAPS LIQUID MANIFOLD	2
7	X02.150.000	REGOLATORE A DISCO ROTANTE COMPLETO	ROTATION DISK REGULATION	6
8	X02.211.090	TUBO Ø16x23 L=900	HOSE Ø16x23 L=900	1
9	X02.211.090	TUBO Ø16x23 L=900	HOSE Ø16x23 L=900	1
10	X02.212.003	TUBO Ø19x28 L=30	HOSE Ø19x28 L=30	1
11	X02.213.007	TUBO Ø10x16 L=70	HOSE Ø10x16 L=70	2
12	X02.213.007	TUBO Ø10x16 L=70	HOSE Ø10x16 L=70	2
13	X02.213.025	TUBO Ø10x16 L=250	HOSE Ø10x16 L=250	2
14	X02.213.030	TUBO Ø10x16 L=300	HOSE Ø10x16 L=300	1
15	X02.213.030	TUBO Ø10x16 L=300	HOSE Ø10x16 L=300	1
16	X02.213.110	TUBO Ø10x16 L=1100	HOSE Ø10x16 L=1100	1
17	X02.213.110	TUBO Ø10x16 L=1100	HOSE Ø10x16 L=1100	1
18	X02.217.033	TUBO Ø8x13 L=330	HOSE Ø8x13 L=330	1
19	X02.217.033	TUBO Ø8x13 L=330	HOSE Ø8x13 L=330	1
20	X02.217.041	TUBO Ø8x13 L=410	HOSE Ø8x13 L=410	1
21	X02.217.041	TUBO Ø8x13 L=410	TUBO Ø8x13 L=410	1
22	X02.217.080	TUBO Ø8x13 L=800	HOSE Ø8x13 L=800	1
23	X02.217.080	TUBO Ø8x13 L=800	HOSE Ø8x13 L=800	1
24	X02.217.100	TUBO Ø8x13 L=1000	HOSE Ø8x13 L=1000	1
25	X02.217.100	TUBO Ø8x13 L=1000	HOSE Ø8x13 L=1000	1
26	X02.265.000	GUARNIZIONE PIANA Ø 20/30 x 2,5	PLANE GASKET Ø 20/30 X 2,5	2
27	X02.349.000	GUARNIZIONE PIANA D.17X23X3	17X23X3 FLAT GASKET (G4000B)	8
28	X02.380.000	NIPPLO 3/4"	NIPPLE 3/4"	4
29	X02.396.000	RACCORDO A T 3/4" - 3/4" - 3/4" F.	UNION 3/4" - 3/4" - 3/4" F.	2
30	X02.999.000	STAFFA FISSAGGIO RACCORDO A T	T UNION FIXING BRACKET	1
31	X20.885.000	RACCORDO A T Ø13-13-13	T UNION Ø 13-13-13	2
32	X21.010.000	RACCORDO P.G. DIRITTO Ø 10 COMPLETO	COMPLETE R.H. Ø 10 UNION	4
33	X21.147.000	VALVOLA A SFERA 1/2" F/F	WAYS VALVE 1/2" F/F	2
34	X21.151.000	RACCORDO DIRITTO PG D. 16	STRAIGHT HOSE R.H. D. 16	2
35	XD0.06.5588G	DADO M6 6S PG 5588 ZINC.	M6 6S BIG LEAD NUT 5588	4
36	XD0.10.5588G	DADO M10 NORMALE 5588G	NUT M10 NORMAL 5588G	2
37	XDA.010.0BG	DADO AUTOBLOCCANTE M10	SELF LOCKING NUT M10	1
38	XFC.012,5.014	FASCETTA COBRA SL030705	KOBRA CLAMP SL030705	4
39	XFC.013,5.015	FASCETTA COBRA SL030710	KOBRA CLAMP SL030710	16
40	XFC.015,5.017	FASCETTA COBRA SLO30720	KOBRA CLAMP	4
41	XFC.016,5.018	FASCETTA COBRA 16,5 - 18	KOBRA CLAMP 16,5 - 18	12
42	XFC.022,5.024	FASCETTA COBRA SLO30756	KOBRA CLAMP SLO30756	2
43	XFC.024,5.026	FASCETTA COBRA 24,5 - 26	KOBRA CLAMP 24,5 - 26	2
44	XOR.000.121	OR D. 15,88 x 2,62	15,88 x 2,62 O-RING GASKET	2
45	XOR.004.081	OR Ø 20,22 x 3,53	20,22 x 3,53 O-RING GASKET	6
46	XRP.006.000	RONDELLA PIANA D.6 6592 ZINC.	6mm D. FLAT WASHER	8
47	XRP.010.000	RONDELLA PIANA D.10 6592 ZINC.	WASHER Ø 10	2
48	XRP.010.030	RONDELLA PIANA F.LARGA D.10X30 ZINC.	10X30mm D. LARGE THREAD FLAT	1
49	XTE.006.020T	VITE TE M6X20 5739 ZINC.	BOLT TE M6X20 5739	4
50	XTE.010.060T	VITE TE UNI 5739-65 M10x60-8.8	SCREW TE UNI 5739-65 M10x60-8.8	1

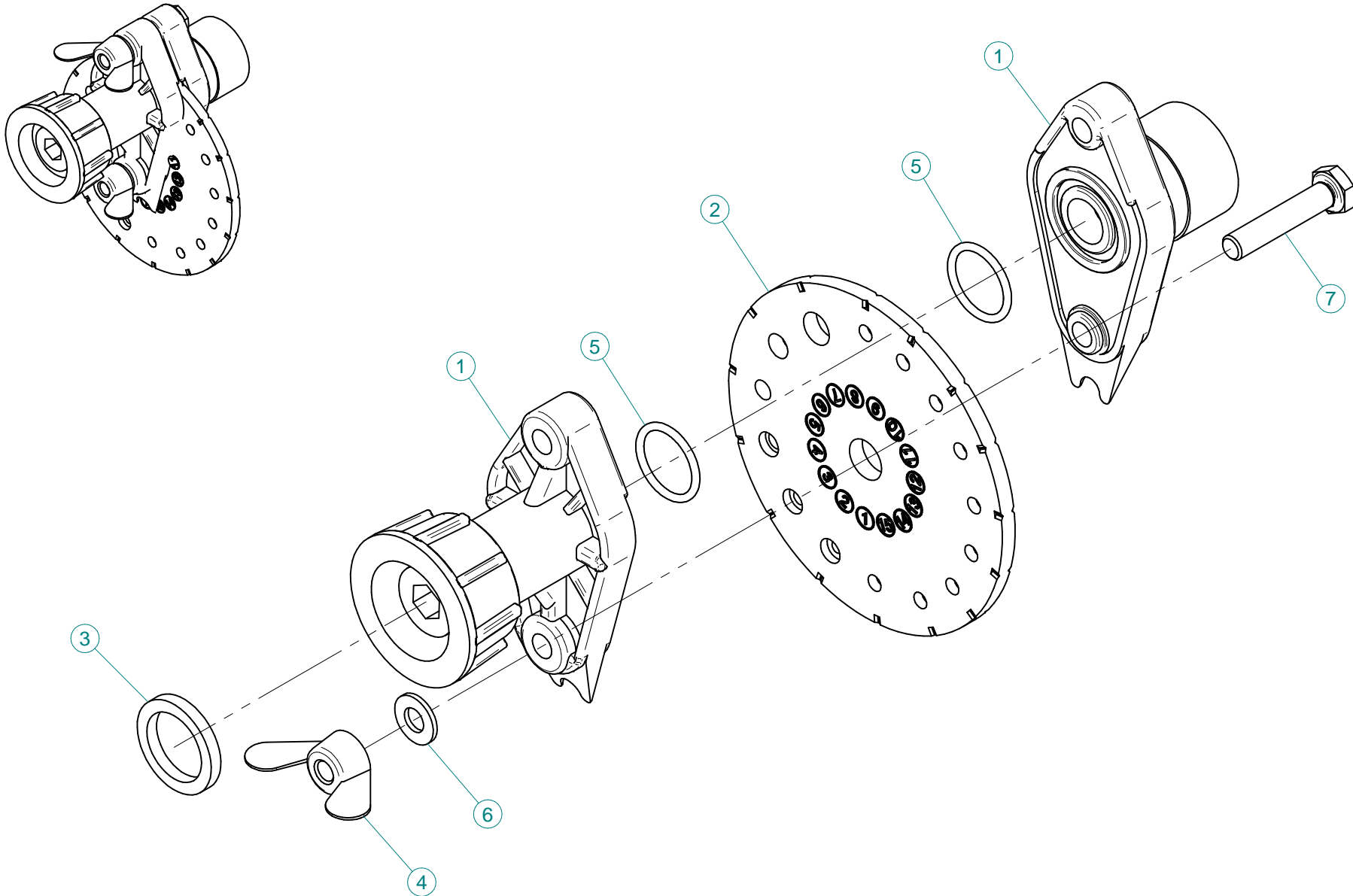

N°	Doc. Number	Titolo	Title	Q.tà
1	X02.147.500	COPPIA DI SEMICORPO REGOLATORE	REGULATOR HALF-BODY	1
2	X02.148.000	DISCO ROTANTE PER REGOLATORE	REGULATOR DISK	1
3	X02.349.000	GUARNIZIONE PIANA D.17X23X3	17X23X3 FLAT GASKET (G4000B)	1
4	XDF.OTT.006	DADO AD ALETTE IN OTTONE M6	BRASS M6 WING NUT	2
5	XOR.002.062	OR D.15,6X1,78	15.6X1.78 O-RING GASKET	2
6	XRP.006.00I	RONDELLA PIANA D.6 INOX	WASHER D.6	2
7	XTE.006.030I	VITE TE M6X30 INOX 5739	BOLT TE M6X30 STAINLESS STEEL 5739	2



N°	Doc. Number	Titolo	Title	Q.tà
1	X00.227.01C	DISPOSITIVO ANTIGOCCIA	ANTI DRIP DEVICE	4
2	X02.008.000	DISTRIBUTORE LIQUIDO TESTATE	SPRAYHEADS LIQUID DISTRIBUTOR	1
3	X20.202.100	RUBINETTO F.1/4" M.18X1,5	TAP ASSEMBLY	4
4	XOR.000.117	OR D.13,1X2,62	13.1X2.62 O-RING GASKET	4

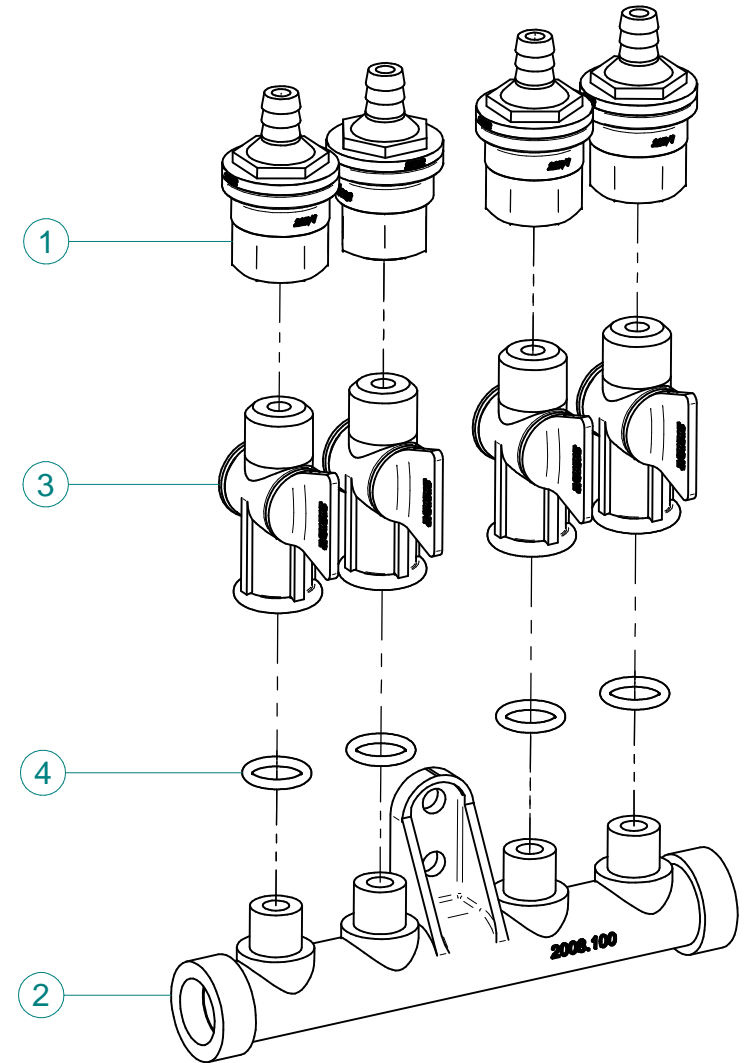
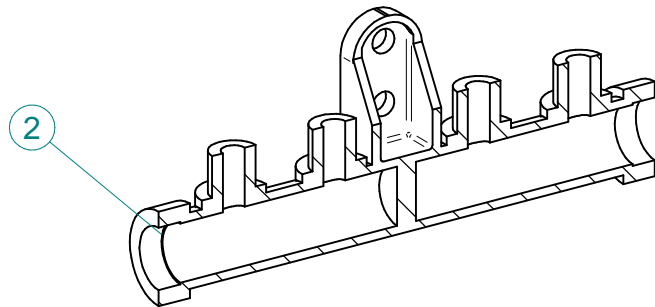

N°	Doc. Number	Titolo	Title	Q.tà
1	X00.227.01C	DISPOSITIVO ANTIGOCCIA	ANTI DRIP DEVICE	4
2	X02.008.100	DISTRIBUTORE LIQUIDO TESTATE DIVISO	SPRAYHEAD LIQUID DISTRIBUTOR	1
3	X20.202.100	RUBINETTO F.1/4" M.18X1,5	TAP ASSEMBLY	4
4	XOR.000.117	OR D.13,1X2,62	13.1X2.62 O-RING GASKET	4

Gli esplosi elencati di seguito sono relativi
a varianti o accessori a richiesta

The exploded drawings listed below are related
to different versions or optional accessories

Le vues éclatées suivantes sont relatives
à des variantes ou à des accessoires optionnels

Dibujos de vista despiezada son relativos a
variantes o accesorios opcionales

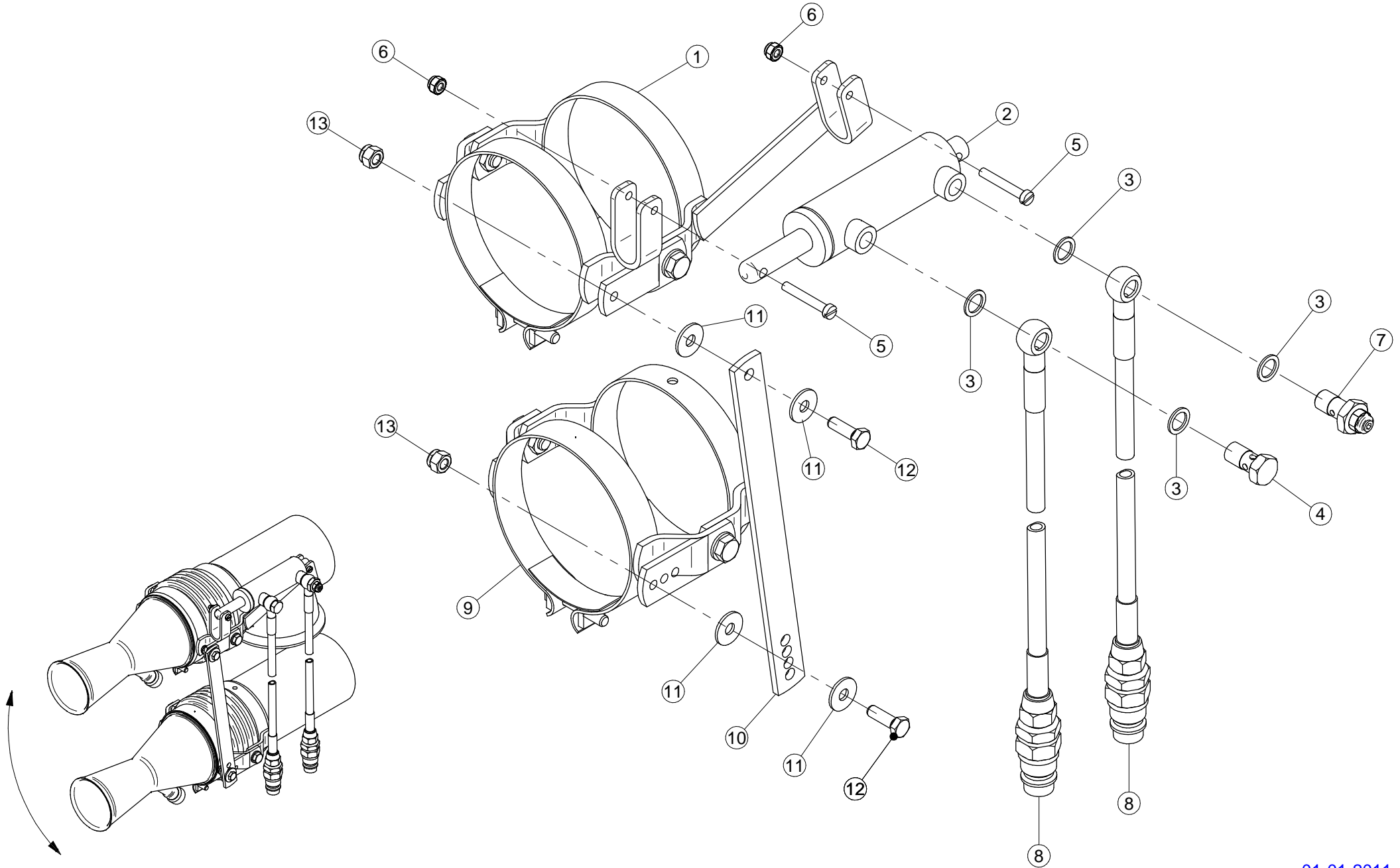

N°	Doc. Number	Titolo	Title	Q.tà	Note
1	X02.140.200	COPPIA FASCETTE ORIENTABILI D.127 CON ATTACCO PISTONE	CLAMP D.127 WITH JACK BRACKET	2	
2	X02.840.04C	MARTINETTO COMPLETO D.20/30 CORSA 60	JACK	2	
3	X02.472.000	RONDELLA DI RAME Ø 19x13,5x1,5	COPPER WASHER Ø 19x13,5x1,5	8	
4	X02.408.000	RACCORDO DRITTO PER OCCHIO 1/4"	JACK EYE RIGHT UNION 1/4"	2	
5	XTC.06.40.07I	VITE T.CIL. M6 x 40 INOX	INOX SCREW M6 x 40	4	
6	XDA.006.0AG	DADO AUTOBLOCCANTE M6	SELF LOCKING NUT M6	4	
7	X20.718.000	REGOLATORE PORTATA IDRAULICA 1/4"	FLOW REGULATOR 1/4"	2	
8	X20.900.370	TUBO OLIO PER MARTINETTO L=3700	OIL PIPE FOR JACK L=3700	4	
9	X02.140.020	COPPIA FASCETTE ORIENTABILI D.127	CANNON SPRAYER CLAMP D.127	2	
10	X20.922.000	STAFFA COLLEGAMENTO PER DIFF.MOVIM. IDRAULICA	UNION BRACKET	2	
11	XRP.008.024	RONDELLA PIANA F.LARGA D.8X24 ZINC.	WASHER D.8X24	8	
12	XTE.008.025T	VITE TE M8X25 5739	BOLT TE M8X25 5739	4	
13	XDA.008.0AG	DADO AUTOBLOCCANTE M8 ALTO PG ZINC.	HIGH BIG LEAD M8 SELFLOCKING	4	

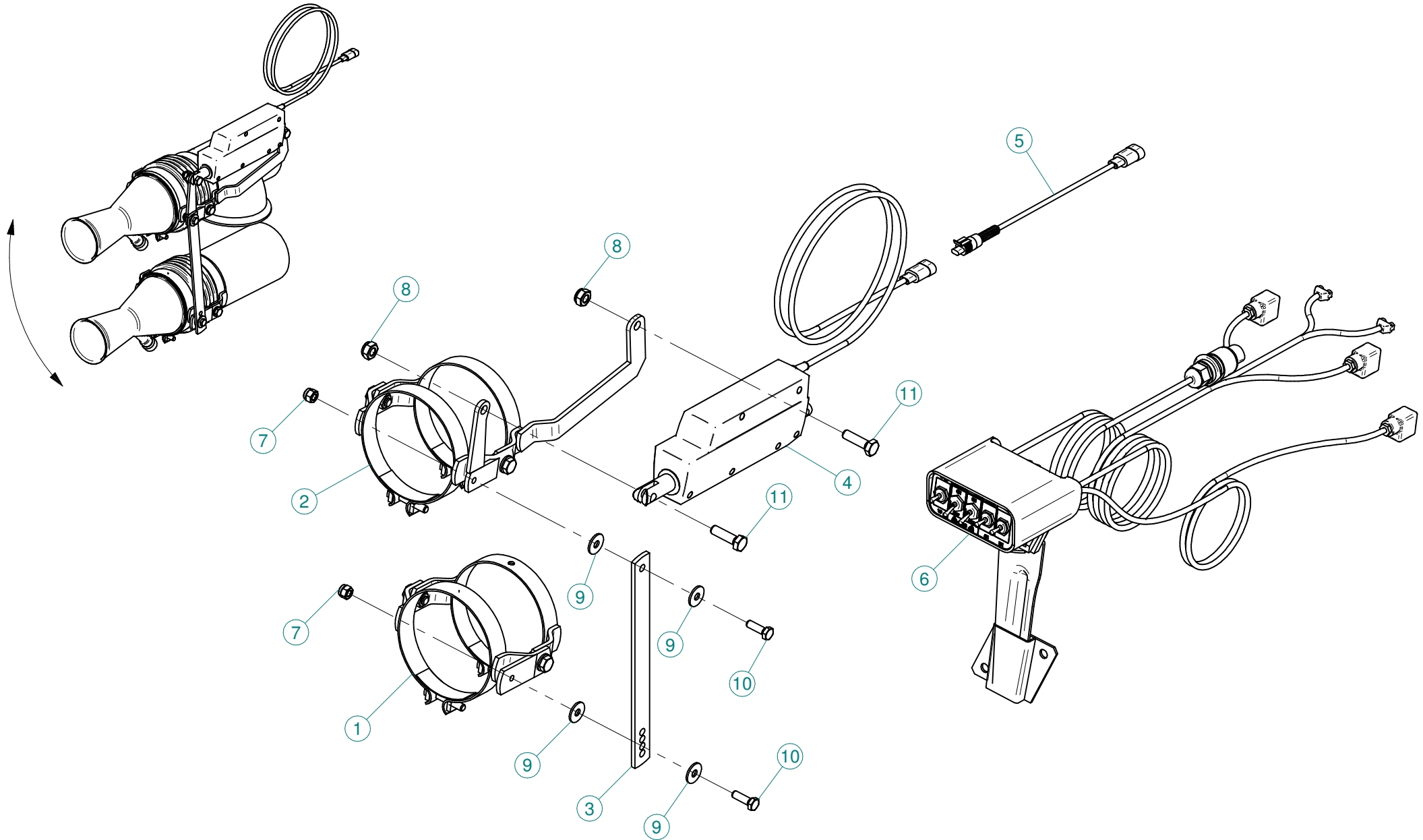

N°	Doc. Number	Titolo	Title	Q.tà
1	X02.140.020 X02.140.120	COPPIA FASCETTE ORIENTABILI D.127	CANNON SPRAYER CLAMP D.127	1 1
2	X02.140.500	COPPIA FASCETTE ORIENTABILI D.127 CON ATTACCO ATTUATORE	CLAMP D.127 WITH ACTUATOR BRACKET	2
3	X20.922.000	STAFFA COLLEGAMENTO PER DIFF.MOVIM. IDRAULICA	UNION BRACKET	2
4	X21.016.000	ATTUATORE LINEARE (LA 12.1)	LINEAR ACTUATOR (LA 12.1)	2
5	X21.474.000	CAVO L=2000 mm COLLEGAMENTO ATTUATORI ELETTRICI	CABLE L=2000 mm ACTUATORS CONNECTION	2
6	X21.530.200	KIT COMANDO ELETTRICO PER PLUS LINK	CONTROL BOX ASSEMBLY FOR PLUS - LINK	1
7	XDA.008.0AG	DADO AUTOBLOCCANTE M8 ALTO PG ZINC.	HIGH BIG LEAD M8 SELFLOCKING	4
8	XDA.010.0BG	DADO AUTOBLOCCANTE M10	SELF LOCKING NUT M10	4
9	XRP.008.024	RONDELLA PIANA F.LARGA D.8X24 ZINC.	WASHER D.8X24	8
10	XTE.008.025T	VITE TE M8X25	BOLT TE M8X25	4
11	XTE.010.035T	VITE TE UNI 5739-65 M10x35-8.8	SCREW TE UNI 5739-65 M10x35-8.8	4



Ø 175
 Plus 42 - 45 - 50
 Blitz 45 - 50
 Link 50

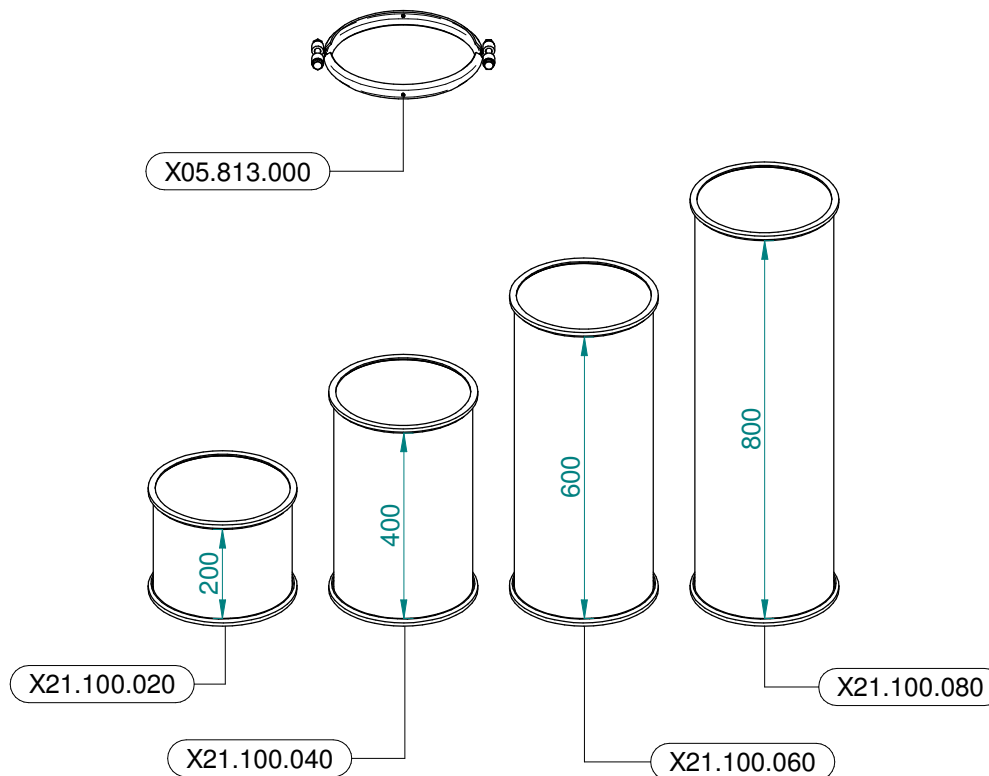

Ø 250
 Plus 55
 Blitz 55
 Link 55