

Sez. T06
Circuito idraulico
Plumbing of liquids

Sez. T01
Telaio
Metallic frame

Sez. T03
Condotto dell'aria
Air duct

Sez. T25 (⌘)
Movimentazione Elettrica
Electrical Movement

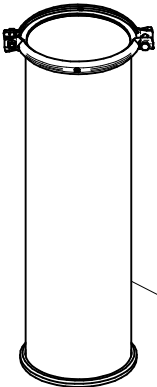
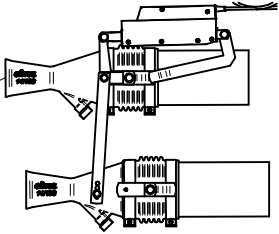

Sez. T28 (⌘)
Prolunghe
Extension

(⌘) A richiesta / Optional Devices

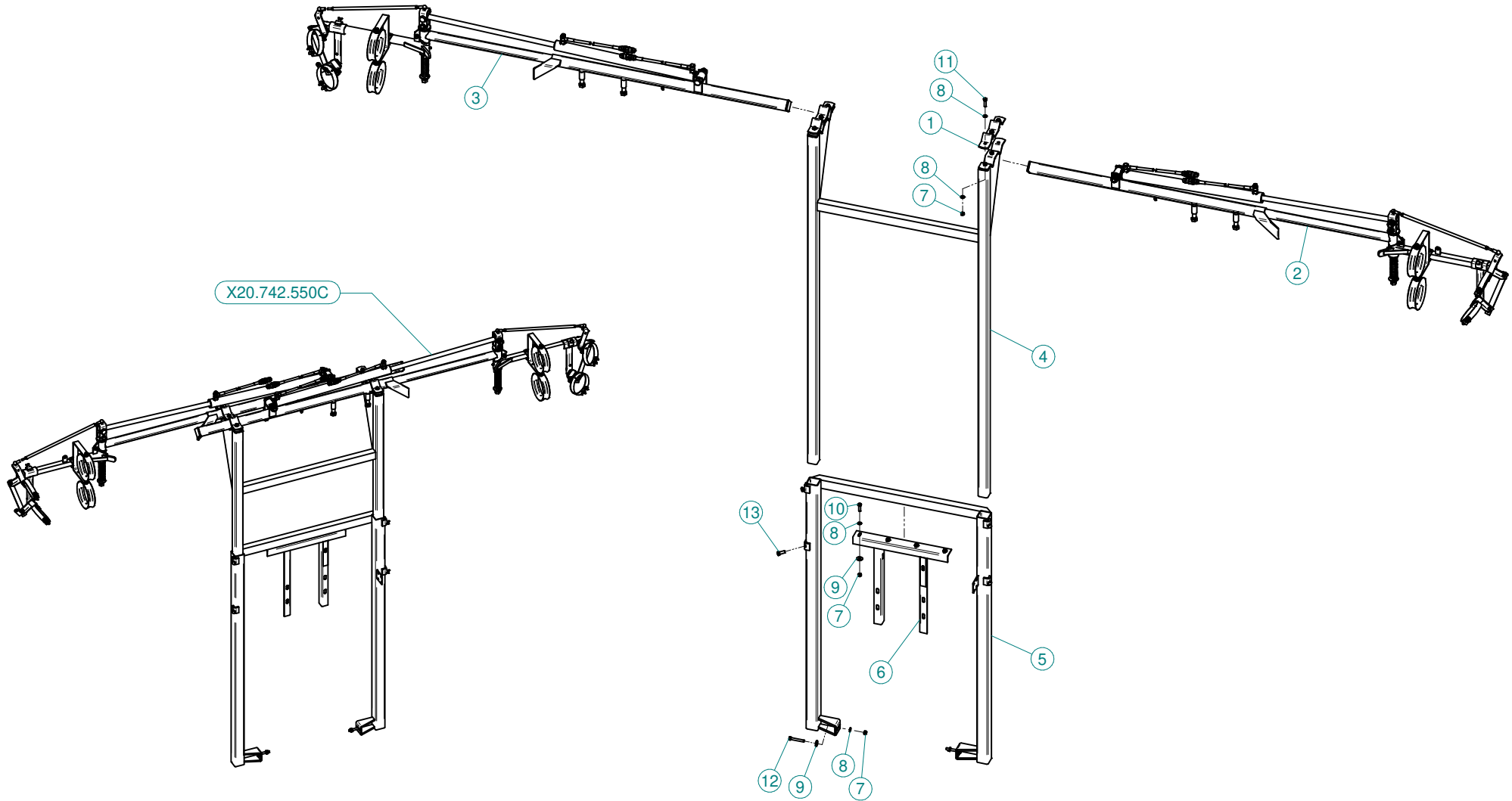

N°	Doc. Number	Titolo	Title	Q.tà
1	X20.742.015	GUIDA BRACCI SCORREVOLE	SLIDING ARMS GUIDE	2
2	X20.742.100X	BRACCIO LATERALE SINISTRO	LEFT ARM	1
3	X20.742.100Y	BRACCIO LATERALE DESTRO	RIGHT ARM	1
4	X20.742.102	TELAIO CENTRALE SCORREVOLE	SLIDING FRAME	1
5	X20.742.551	TELAIO CENTRALE FISSO	CENTRAL FRAME	1
6	X20.868.200	TELAIO ATTACCO CROCIERA	CENTRALE FRAME	1
7	XD0.10.5587G	DADO M10 6S PG 5587 ZINC.	M10 6S BIG LEAD NUT 5587	10
8	XRP.010.000	RONDELLA PIANA D.10 6592 ZINC.	WASHER Ø 10	16
9	XRP.010.030	RONDELLA PIANA F.LARGA D.10X30 ZINC.	10X30mm D. LARGE THREAD FLAT	6
10	XTE.010.035T	VITE TE UNI 5739-65 M10x35-8.8	SCREW TE UNI 5739-65 M10x35-8.8	4
11	XTE.010.040T	VITE TE UNI 5739-65 M10x40-8.8	SCREW TE UNI 5739-65 M10x40-8.8	6
12	XTE.010.070T	VITE TE UNI 5739-65 M10x70-8.8	SCREW TE UNI 5739-65 M10x70-8.8	2
13	XTE.012.030T	VITE TE UNI 5739-65 M12x30-8.8	SCREW TE UNI 5739-65 M12x30-8.8	4

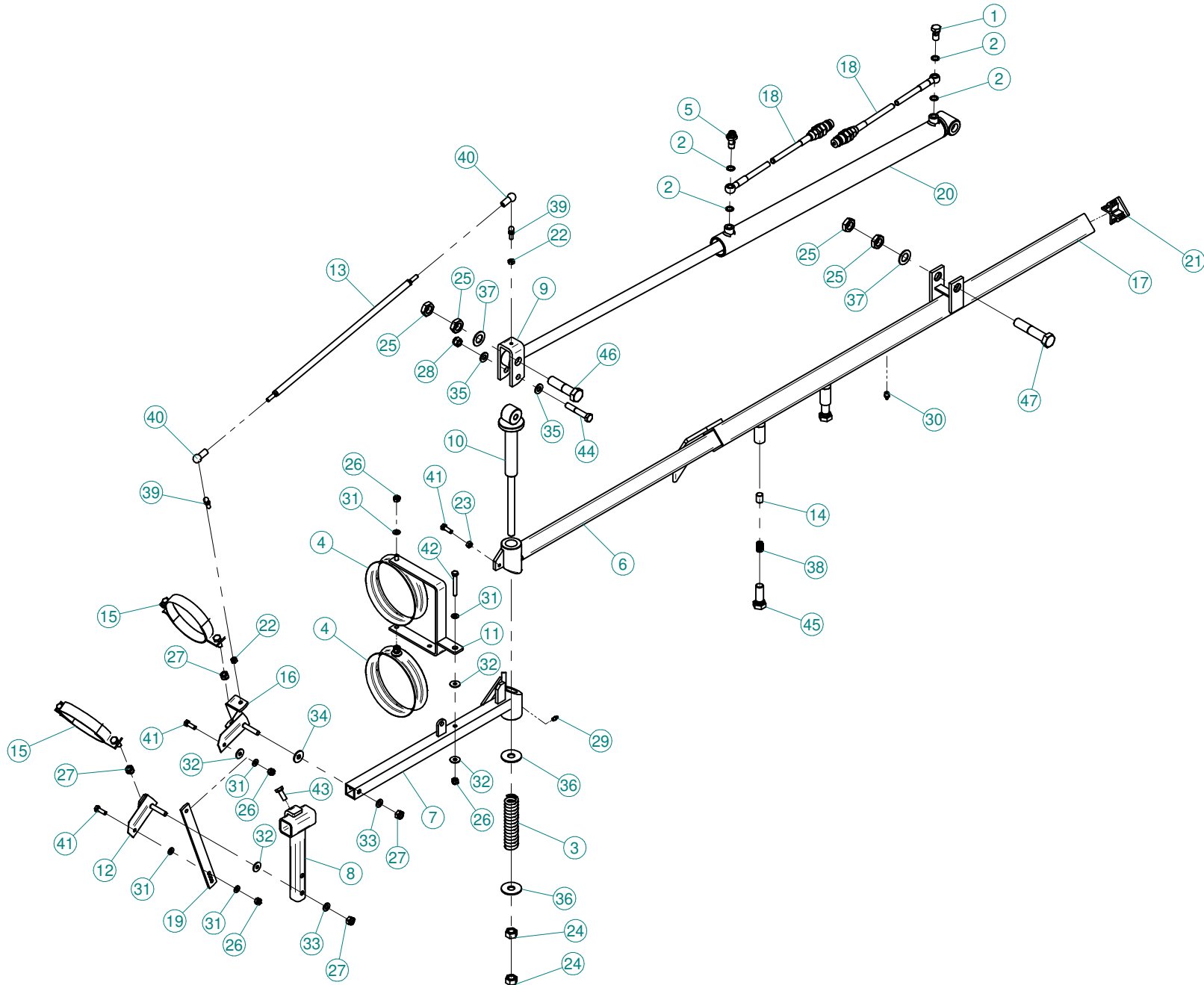

N°	Doc. Number	Titolo	Title	Q.tà
1	X02.408.000	RACCORDO DRITTO PER OCCHIO 1/4"	JACK EYE RIGHT UNION 1/4"	1
2	X02.472.000	RONDELLA DI RAME Ø 19x13,5x1,5	COPPER WASHER Ø 19x13,5x1,5	4
3	X07.528.000	MOLLA A COMPRESSIONE INT.D.20XF.D.6XL=140	SPRING INT.D.20XF.D.6XL=140	1
4	X20.227.000	ANELLO GUIDA TUBI PICCOLO	SMALL PIPE GUIDE RING	2
5	X20.718.000	REGOLATORE PORTATA IDRAULICA 1/4"	FLOW REGULATOR 1/4"	1
6	X20.742.003DX	BRACCIO LATERALE DESTRO SCORREVOLE	SLIDING RIGHT SIDE ARM	1
7	X20.742.004DX	BRACCIO LATERALE DESTRO RIPIEGABILE	TURNING RIGHT SIDE ARM	1
8	X20.742.005	ATTACCO ANELLO PICCOLO	SMALL RING ATTACH	1
9	X20.742.006Z	CAVALLOTTO DI TRASCINAMENTO	U BOLT	1
10	X20.742.007Z	PERNO D.28 COMPLETO	PIN	1
11	X20.742.008	ATTACCO ANELLO GROSSO	LARGE RING ATTACH	1
12	X20.742.010DX	ATTACCO ANELLO PICCOLO	SMALL RING ATTACH	1
13	X20.742.012	ASTA DI COLLEGAMENTO	UNION ROD	1
14	X20.742.014	TONDINO D.15 L=20	PIN D.15 L=20	2
15	X20.742.018	ATTACCO ANELLO PICCOLO	SMALL RING ATTACH	2
16	X20.742.024DX	ATTACCO ANELLO PICCOLO	SMALL RING ATTACH	1
17	X20.742.116DX	BRACCIO LATERALE DESTRO FISSO	FIXING RIGHT SIDE ARM	1
18	X20.900.680	TUBO OLIO PER MARTINETTO L=6800	OIL PIPE FOR JACK L=6800	2
19	X20.922.000	STAFFA COLLEGAMENTO PER DIFF.MOVIM. IDRAULICA	UNION BRACKET	1
20	X21.115.000A	MARTINETTO COMPLETO CORSA L=640	COMPLETE JACK	1
21	X21.314.000	TAPPO IN PLASTICA 50x50	TAPPO IN PLASTICA 50x50	1
22	XD0.08.5588G	DADO M8 6S PG	M8 6S BIG LEAD NUT 5588	2
23	XD0.08.5588G	DADO M8 6S PG 5588 ZINC.	M8 6S BIG LEAD NUT 5588	1
24	XD0.16.5587G	DADO M16	NUT M16	2
25	XD0.20.5589G	DADO BASSO M20	LOWER NUT M20	4
26	XDA.008.0AG	DADO AUTOBLOCCANTE M8 ALTO PG ZINC.	HIGH BIG LEAD M8 SELFLOCKING	5
27	XDA.010.0AG	DADO AUTOBLOCCANTE M10	SELF LOCKING NUT M10	4
28	XDA.012.0AG	DADO AUTOBLOCCANTE M12	SELF LOCKING NUT M12	1
29	XID.006.001	INGRASSATORE DIRITTO M6	GREASER	1
30	XID.010.001	INGRASSATORE DIRITTO M 10X1 ZINC.	STRAIGHT GREASE NIPPLE	1
31	XRP.008.000	RONDELLA PIANA D.8 6592 ZINC.	8 D. FLAT WASHER	6
32	XRP.008.024	RONDELLA PIANA F.LARGA D.8X24 ZINC.	WASHER D.8X24	4
33	XRP.010.000	RONDELLA PIANA D.10 6592 ZINC.	WASHER Ø 10	2
34	XRP.010.030	RONDELLA PIANA F.LARGA D.10X30 ZINC.	10X30mm D. LARGE THREAD FLAT	1
35	XRP.012.000	RONDELLA PIANA Ø12	WASHER Ø12	2
36	XRP.016.048	RONDELLA PIANA D.16 x 48	WASHER	2
37	XRP.020.000	RONDELLA PIANA D.20	WASHER D.20	2
38	XS0.211.000	MOLLA D.INT. 9 x F.D.2,3 x L=22	SPRING	2
39	XS0.212.000A	SPINA ATTACCO SNODO	JOINT PIN	2
40	XS0.212.000B	SNODO	JOINT	2
41	XTE.008.025T	VITE TE M8X25	BOLT TE M8X25	3
42	XTE.008.060T	VITE TE UNI 5739-65 M8x60-8.8	SCREW TE UNI 5739-65 M8x60-8.8	1
43	XTE.010.025	VITE TE UNI 5737-65 M10x25-8.8	SCREW TE UNI 5737-65 M10x25-8.8	1
44	XTE.012.070	VITE TE UNI 5737-65 M12x70-8.8	SCREW TE UNI 5737-65 M12x70-8.8	1
45	XTE.018.050T	VITE TE UNI 5737-65 M18x50-8.8	SCREW TE UNI 5737-65 M18x50-8.8	2
46	XTE.020.080	VITE TE UNI 5737-65 M20x80-8.8	SCREW TE UNI 5737-65 M20x80-8.8	1
47	XTE.020.100	VITE TE UNI 5737-65 M20x100-8.8	SCREW TE UNI 5737-65 M20x100-8.8	1

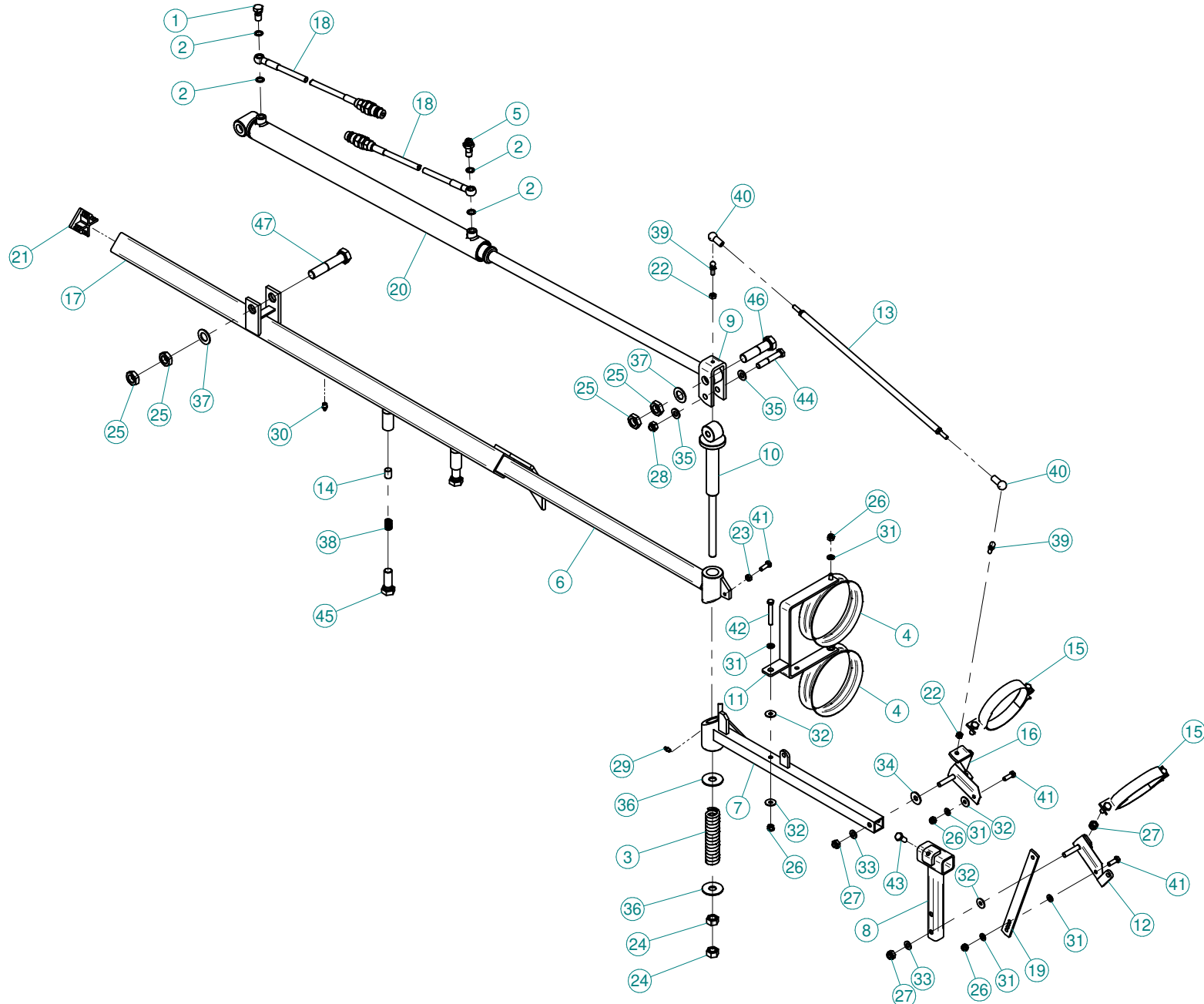

N°	Doc. Number	Titolo	Title	Q.tà	N°	Doc. Number	Titolo	Title	Q.tà
1	X02.408.000	RACCORDO DRITTO PER OCCHIO 1/4"	JACK EYE RIGHT UNION 1/4"	1	43	XTE.010.025	VITE TE UNI 5737-65 M10x25-8.8	SCREW TE UNI 5737-65 M10x25-8.8	1
2	X02.472.000	RONDELLA DI RAME Ø 19x13,5x1,5	COPPER WASHER Ø 19x13,5x1,5	4	44	XTE.012.070	VITE TE UNI 5737-65 M12x70-8.8	SCREW TE UNI 5737-65 M12x70-8.8	1
3	X07.528.000	MOLLA A COMPRESSIONE INT.D.20XF.D.6XL=140	SPRING INT.D.20XF.D.6XL=140	1	45	XTE.018.050T	VITE TE UNI 5737-65 M18x50-8.8	SCREW TE UNI 5737-65 M18x50-8.8	2
4	X20.227.000	ANELLO GUIDA TUBI PICCOLO	SMALL PIPE GUIDE RING	2	46	XTE.020.080	VITE TE UNI 5737-65 M20x80-8.8	SCREW TE UNI 5737-65 M20x80-8.8	1
5	X20.718.000	REGOLATORE PORTATA IDRAULICA 1/4"	FLOW REGULATOR 1/4"	1	47	XTE.020.100	VITE TE UNI 5737-65 M20x100-8.8	SCREW TE UNI 5737-65 M20x100-8.8	1
6	X20.742.003SX	BRACCIO LATERALE SINISTRO SCORREVOLE	SLIDING LEFT SIDE ARM	1					
7	X20.742.004SX	BRACCIO LATERALE SINISTRO RIPIEGABILE	TURNING LEFT SIDE ARM	1					
8	X20.742.005	ATTACCO ANELLO PICCOLO	SMALL RING ATTACH	1					
9	X20.742.006Z	CAVALLOTTO DI TRASCINAMENTO	U BOLT	1					
10	X20.742.007Z	PERNO D.28 COMPLETO	PIN	1					
11	X20.742.008	ATTACCO ANELLO GROSSO	LARGE RING ATTACH	1					
12	X20.742.010SX	ATTACCO ANELLO PICCOLO	SMALL RING ATTACH	1					
13	X20.742.012	ASTA DI COLLEGAMENTO	UNION ROD	1					
14	X20.742.014	TONDINO D.15 L=20	PIN D.15 L=20	2					
15	X20.742.018	ATTACCO ANELLO PICCOLO	SMALL RING ATTACH	2					
16	X20.742.024SX	ATTACCO ANELLO PICCOLO	SMALL RING ATTACH	1					
17	X20.742.116SX	BRACCIO LATERALE SINISTRO FISSO	FIXING LEFT SIDE ARM	1					
18	X20.900.680	TUBO OLIO PER MARTINETTO L=6800	OIL PIPE FOR JACK L=6800	2					
19	X20.922.000	STAFFA COLLEGAMENTO PER DIFF.MOVIM. IDRAULICA	UNION BRACKET	1					
20	X21.115.000A	MARTINETTO COMPLETO CORSA L=640	COMPLETE JACK	1					
21	X21.314.000	TAPPO IN PLASTICA 50x50	TAPPO IN PLASTICA 50x50	1					
22	XD0.08.5588G	DADO M8 6S PG	M8 6S BIG LEAD NUT 5588	2					
23	XD0.08.5588G	DADO M8 6S PG 5588 ZINC.	M8 6S BIG LEAD NUT 5588	1					
24	XD0.16.5587G	DADO M16	NUT M16	2					
25	XD0.20.5589G	DADO BASSO M20	LOWER NUT M20	4					
26	XDA.008.0AG	DADO AUTOBLOCCANTE M8 ALTO PG ZINC.	HIGH BIG LEAD M8 SELFLOCKING	5					
27	XDA.010.0AG	DADO AUTOBLOCCANTE M10	SELF LOCKING NUT M10	4					
28	XDA.012.0AG	DADO AUTOBLOCCANTE M12	SELF LOCKING NUT M12	1					
29	XID.006.001	INGRASSATORE DIRITTO M6	GREASER	1					
30	XID.010.001	INGRASSATORE DIRITTO M 10X1 ZINC.	STRAIGHT GREASE NIPPLE	1					
31	XRP.008.000	RONDELLA PIANA D.8 6592 ZINC.	8 D. FLAT WASHER	6					
32	XRP.008.024	RONDELLA PIANA F.LARGA D.8X24 ZINC.	WASHER D.8X24	4					
33	XRP.010.000	RONDELLA PIANA D.10 6592 ZINC.	WASHER Ø 10	2					
34	XRP.010.030	RONDELLA PIANA F.LARGA D.10X30 ZINC.	10X30mm D. LARGE THREAD FLAT	1					
35	XRP.012.000	RONDELLA PIANA Ø12	WASHER Ø12	2					
36	XRP.016.048	RONDELLA PIANA D.16 x 48	WASHER	2					
37	XRP.020.000	RONDELLA PIANA D.20	WASHER D.20	2					
38	XS0.211.000	MOLLA D.INT. 9 x F.D.2,3 x L=22	SPRING	2					
39	XS0.212.000A	SPINA ATTACCO SNODO	JOINT PIN	2					
40	XS0.212.000B	SNODO	JOINT	2					
41	XTE.008.025T	VITE TE M8X25	BOLT TE M8X25	3					
42	XTE.008.060T	VITE TE UNI 5739-65 M8x60-8.8	SCREW TE UNI 5739-65 M8x60-8.8	1					

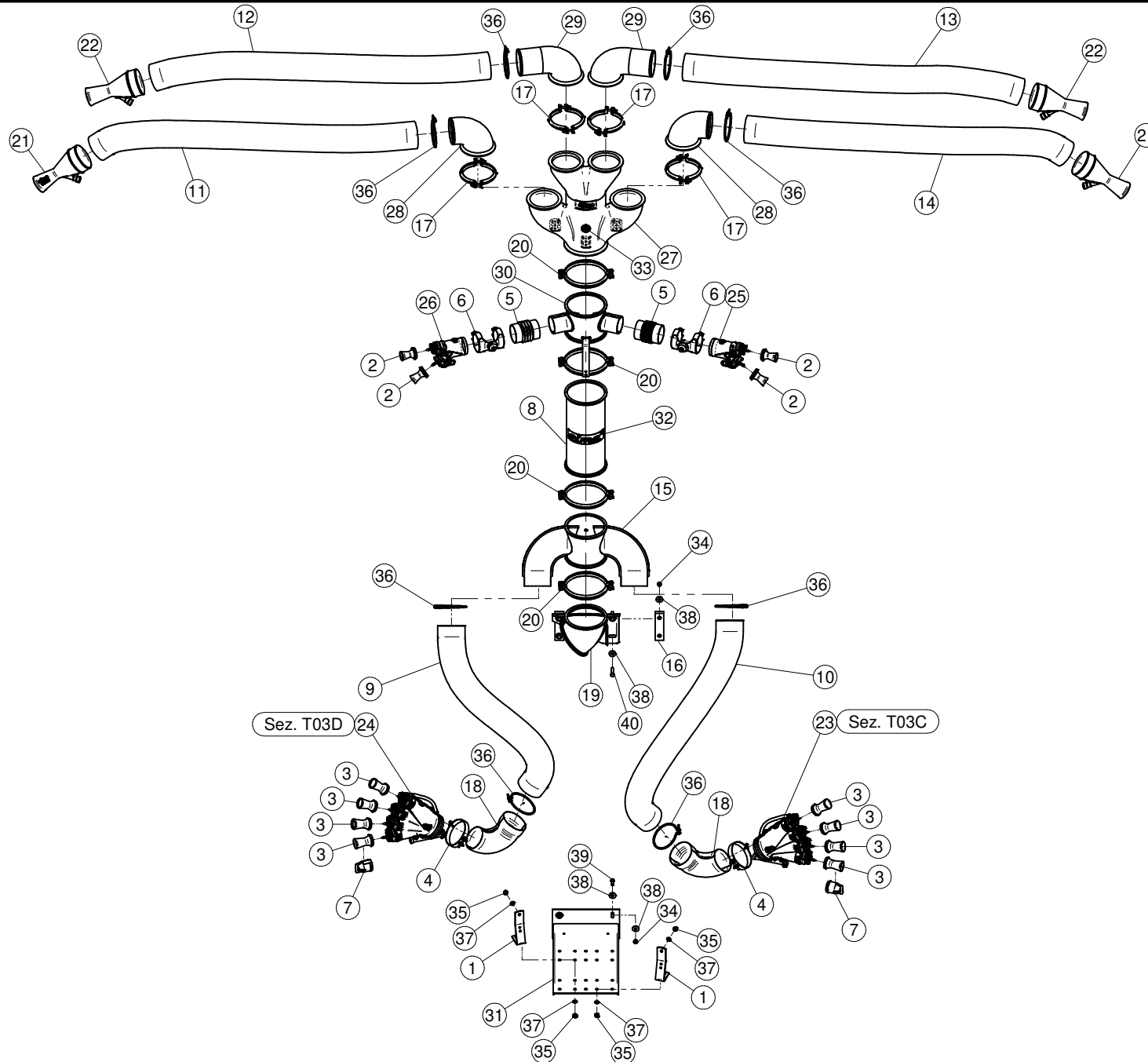

N°	Doc. Number	Titolo	Title	Q.tà
1	X20.283.100	SQUADRETTA FISSAGGIO MANI	OUTLET'S JOINT PLATE	2
2	X00.003.5.50	DIFFUSORE 3,5/50	NOZZLE 3,5/50	4
3	X00.006.050	DIFFUSORE 6/50	NOZZLE 6/50	8
4	X00.125.001	FEMMINA FASCETTA D.125 ORIENTABILE	FEMALE CLAMP D.125	2
5	X02.020.000	MANICOTTO FLESSIBILE Ø 80 x 115	FLEXIBLE SLEEVE Ø 80 x 115	2
6	X02.046.000	COPPIA FASCETTE Ø 85	CLAMP Ø 85	2
7	X02.127.000	TAPPO DI ATTACCO RAPIDO	CAP NOZZLE PLUG	2
8	X02.187.000	PROLUNGA Ø 175 X 400	EXTENSION D.175 X 400	1
9	X02.239.120	TUBO SPIRALATO D.120 L=1200	TANEGUM HOSE D.120 L=1200	1
10	X02.239.120	TUBO SPIRALATO D.120 L=1200	TANEGUM HOSE D.120 L=1200	1
11	X02.239.150	TUBO SPIRALATO D.120 L=1500	TANEGUM HOSE D.120 L=1500	1
12	X02.239.150	TUBO SPIRALATO D.120 L=1500	TANEGUM HOSE D.120 L=1500	1
13	X02.239.150	TUBO SPIRALATO D.120 L=1500	TANEGUM HOSE D.120 L=1500	1
14	X02.239.150	TUBO SPIRALATO D.120 L=1500	TANEGUM HOSE D.120 L=1500	1
15	X02.866.400	CORPO A 2 USCITE Ø120 PER BLITZ "A"	BODY 2 USCITE Ø120 PER BLITZ "A"	1
16	X02.992.000	STAFFA FISSAGGIO CURVE	BRACKET	2
17	X04.027.000	COLLARE PER TUBI D. 150	PIPE CLAMP D. 150	4
18	X04.845.000	CURVA D.120 A 105°	ELBOW D.120 A 105°	2
19	X04.877.000	CURVA A 45° Ø175	45° BEND Ø175	1
20	X05.616.000	COLLARE PER TUBI Ø 175	PIPE CLAMP Ø 175	4
21	X10.014.120	DIFFUSORE 14/120	CANNON 14/120	2
22	X10.018.120	DIFFUSORE 18/120 CON TUBETTO	NOZZLE 18/120	2
23	X20.014.804CDX	MANO A 4 USCITE COMPLETA DI DISTRIBUTORE	FOUR NOZZLES DIFFUSER	1
24	X20.014.804CSX	MANO A 4 USCITE COMPLETA DI DISTRIBUTORE	FOUR NOZZLES DIFFUSER	1
25	X20.221.100DX	MANO Ø 80 A DUE USCITE	TWO OUTLETS BODY	1
26	X20.221.100SX	MANO Ø 80 A DUE USCITE	TWO OUTLETS BODY	1
27	X20.644.000	CORPO TESTATA D.175 CON 4 USCITE D.120	SPRAYHEAD BODY D.175 WITH 4 OUTLETS D.120	1
28	X20.644.003	CURVA D.120 L=130	ELBOW D.120 L=130	2
29	X20.644.004	CURVA D.120 L=220	ELBOW D.120 L=220	2
30	X20.890.300	TRONCHETTO Ø 175 L=150 CON 2 USCITE Ø 80	EXTENSION Ø 175 L=150 WITH 2 OUTLETS Ø 80	1
31	X50.282.001	STAFFA FISSAGGIO CURVE 90° SU LINK E PLUS 50 e 55	BRACKET	1
32	X96.118.000	ADESIVO - CIMA 100x200	DECALS - CIMA 100x200	1
33	X96.158.000	ADESIVO 50 PER TESTATE	DECALS 50 FOR HEADS	1
34	XD0.10.5587G	DADO M10 6S PG 5587 ZINC.	M10 6S BIG LEAD NUT 5587	8
35	XDA.010.0BG	DADO AUTOBLOCCANTE M10	SELF LOCKING NUT M10	4
36	XF0.120.000	FASCETTA UNIFILO D.120	CLAMP D.120	8
37	XRP.010.000	RONDELLA PIANA D.10 6592 ZINC.	WASHER Ø 10	4
38	XRP.010.030	RONDELLA PIANA F.LARGA D.10X30 ZINC.	10X30mm D. LARGE THREAD FLAT	16
39	XTE.010.030T	VITE TE UNI 5739-65 M10x30-8.8	SCREW TE UNI 5739-65 M10x30-8.8	4
40	XTE.010.050T	VITE TE M10X50 5739 ZINC.	BOLT TE M10X50 5739	4

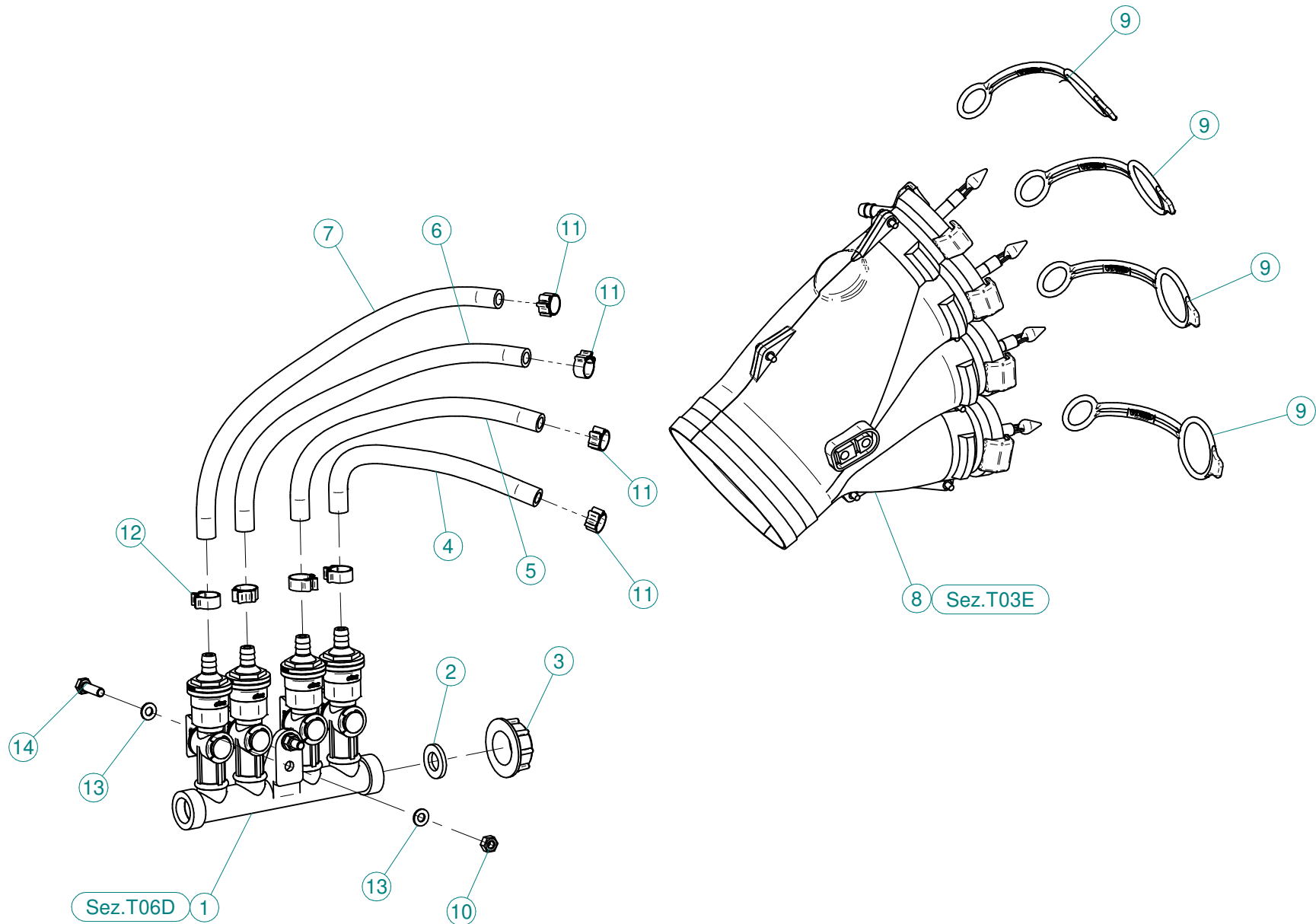

N°	Doc. Number	Titolo	Title	Q.tà
1	X02.008.304C	DISTRIBUTORE LIQUIDI A 4 RUBINETTI CON ANTIGOCCIA	FOUR TAPS LIQUID DISTRIBUTOR WITH ANTI-DRIP DEVICE	1
2	X02.030.010	GUARNIZIONE IN GOMMA D.24X13X3	GASKET D.24X13X3	1
3	X02.182.000	TAPPO 3/4" F.	FEMALE 3/4" CAP	1
4	X02.217.018	TUBO D. 8x13 L=180	HOSE D. 8x13 L=180	1
5	X02.217.022	TUBO D. 8x13 L=220	HOSE D. 8x13 L=220	1
6	X02.217.026	TUBO D. 8x13 L=260	HOSE D. 8x13 L=260	1
7	X02.217.029	TUBO D. 8x13 L=290	HOSE D. 8x13 L=290	1
8	X20.014.000DX	MANO A 4 USCITE CON TUBETTI	FOUR OUTLETS	1
9	X20.697.000	FERMA DIFFUSORI	NOZZLE STOP	4
10	XD0.06.5588G	DADO M6 6S PG 5588 ZINC.	M6 6S BIG LEAD NUT 5588	2
11	XFC.012,5.014	FASCETTA COBRA SL030705	KOBRA CLAMP SL030705	4
12	XFC.013,5.015	FASCETTA COBRA SL030710	KOBRA CLAMP SL030710	4
13	XRP.006.000	RONDELLA PIANA D.6 6592 ZINC.	6mm D. FLAT WASHER	4
14	XTE.006.020T	VITE TE M6X20 5739 ZINC.	BOLT TE M6X20 5739	2

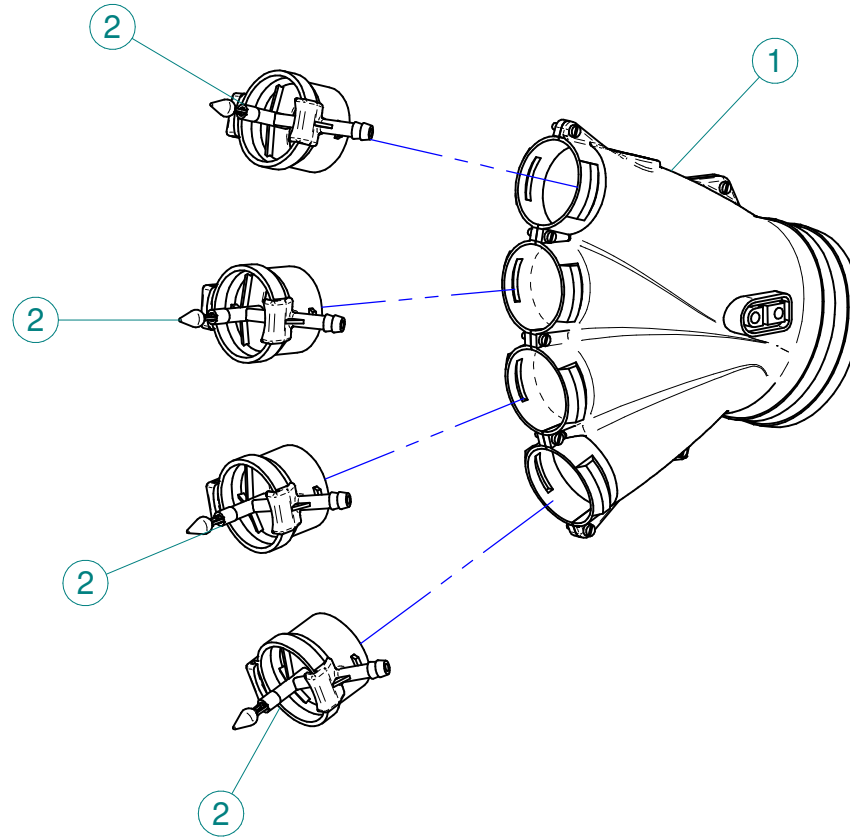

N°	Doc. Number	Titolo	Title	Q.tà
1	X20.014.001DX	MANO A 4 USCITE NUDA	FOUR OUTLETS	1
2	X20.016.01C	RACCORDO ATTACCO RAPIDO PORTA TUBETTO	PIPE WITH OLIVE	4

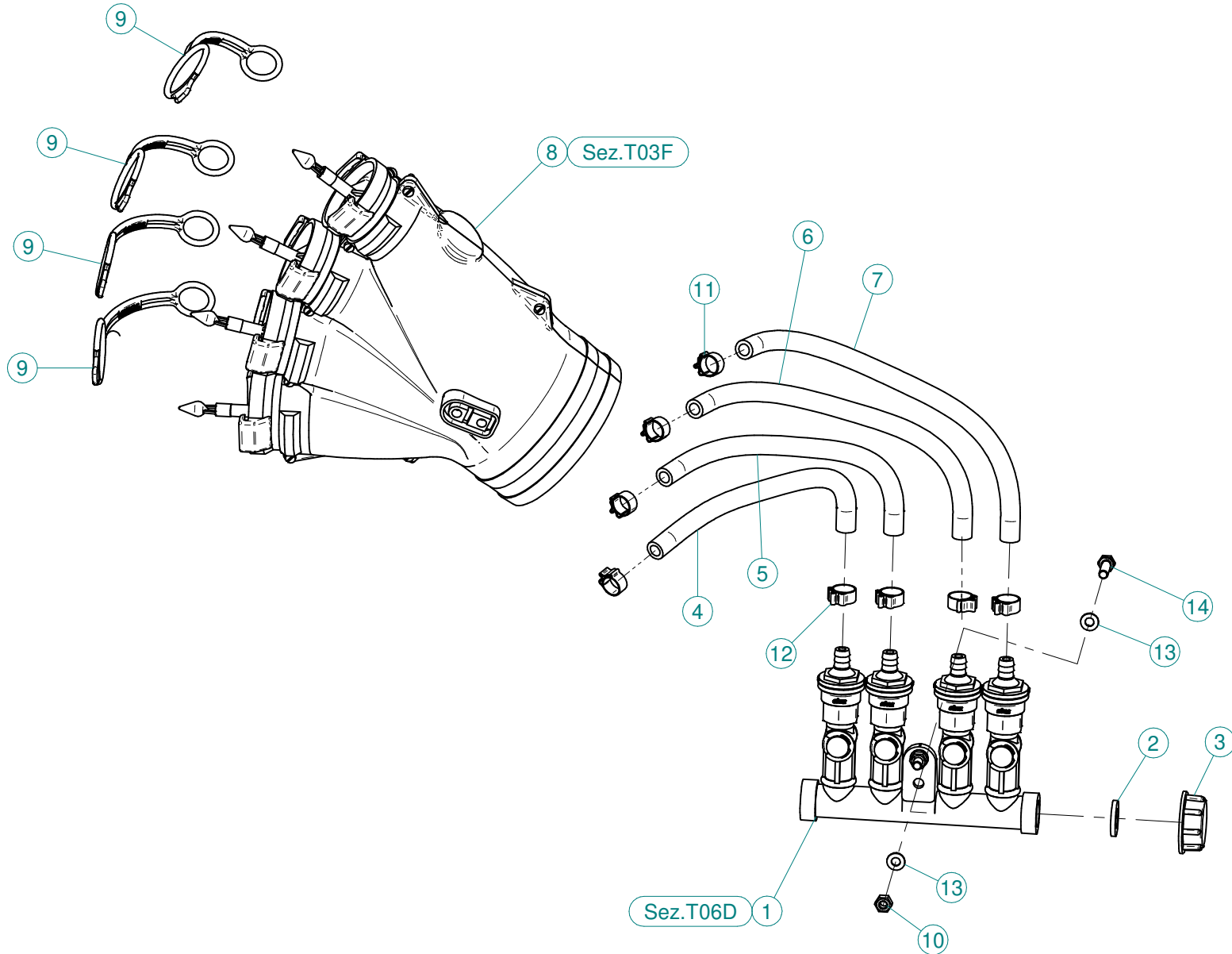

N°	Doc. Number	Titolo	Title	Q.tà
1	X02.008.304C	DISTRIBUTORE LIQUIDI A 4 RUBINETTI CON ANTIGOCCIA	FOUR TAPS LIQUID DISTRIBUTOR WITH ANTI-DRIP DEVICE	1
2	X02.030.010	GUARNIZIONE IN GOMMA D.24X13X3	GASKET D.24X13X3	1
3	X02.182.000	TAPPO 3/4" F.	FEMALE 3/4" CAP	1
4	X02.217.018	TUBO D.8x13 L=180	HOSE D. 8x13 L=180	1
5	X02.217.022	TUBO D. 8x13 L=220	HOSE D. 8x13 L=220	1
6	X02.217.026	TUBO D. 8x13 L=260	HOSE D. 8x13 L=260	1
7	X02.217.029	TUBO D. 8x13 L=290	HOSE D. 8x13 L=290	1
8	X20.014.000SX	MANO A 4 USCITE CON TUBETTI	FOUR OUTLETS	1
9	X20.697.000	FERMA DIFFUSORI	NOZZLE STOP	4
10	XD0.06.5588G	DADO M6 6S PG 5588 ZINC.	M6 6S BIG LEAD NUT 5588	2
11	XFC.012,5.014	FASCETTA COBRA SL030705	KOBRA CLAMP SL030705	4
12	XFC.013,5.015	FASCETTA COBRA SL030710	KOBRA CLAMP SL030710	4
13	XRP.006.000	RONDELLA PIANA D.6 6592 ZINC.	6mm D. FLAT WASHER	4
14	XTE.006.020T	VITE TE M6X20 5739 ZINC.	BOLT TE M6X20 5739	2

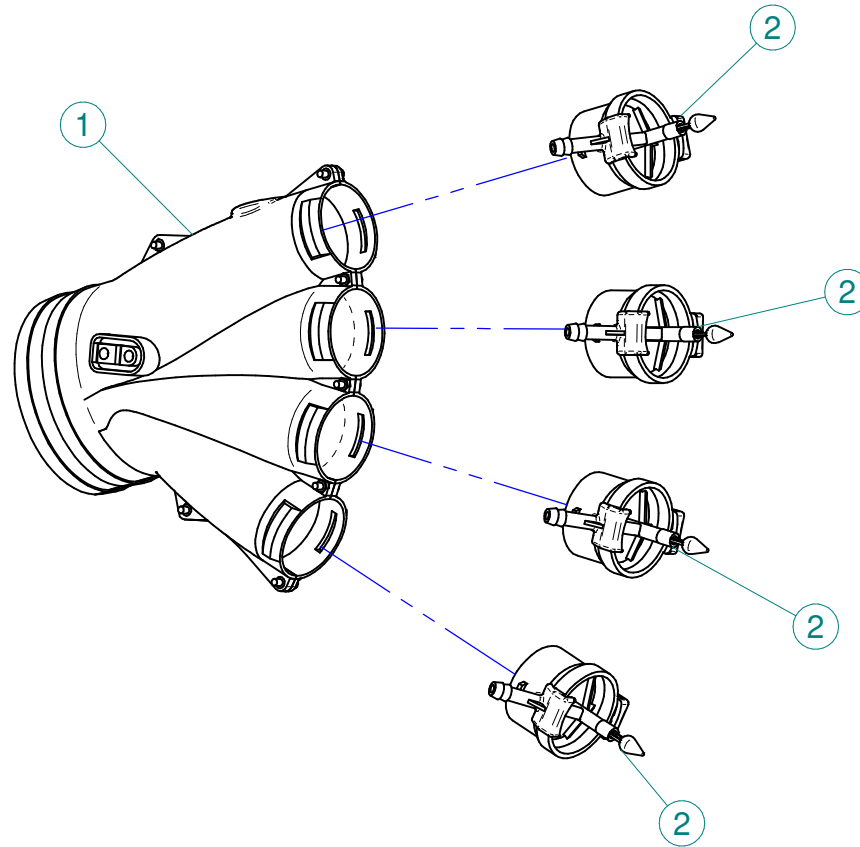

N°	Doc. Number	Titolo	Title	Q.tà
1	X20.014.001DX	MANO A 4 USCITE NUDA	FOUR OUTLETS	1
2	X20.016.01C	RACCORDO ATTACCO RAPIDO PORTA TUBETTO	PIPE WITH OLIVE	4

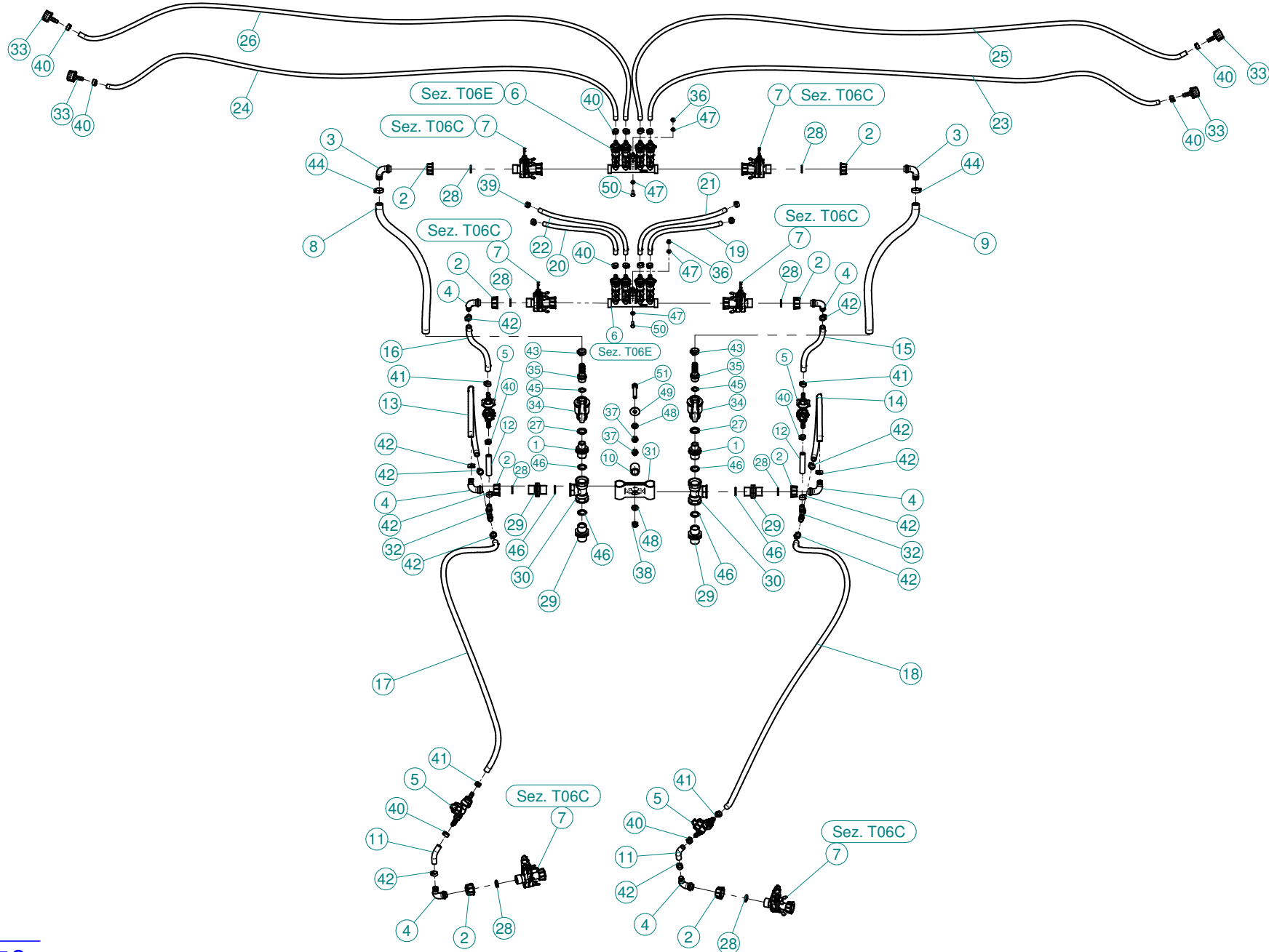

N°	Doc. Number	Titolo	Title	Q.tà	N°	Doc. Number	Titolo	Title	Q.tà
1	X00.055.044	NIPPLO 1/2" GAS 3/4" GAS	NIPPLE 1/2" - 3/4" GAS	2	38	XDA.010.0BG	DADO AUTOBLOCCANTE M10	SELF LOCKING NUT M10	1
2	X00.055.045	GIRELLO 3/4" GAS ALTO	3/4" GAS FLY NUT	8	39	XFC.012.5.014	FASCETTA COBRA SL030705	KOBRA CLAMP SL030705	4
3	X00.055.046	RACCORDO CURVO P.G. Ø16	CURVED UNION WITH R.H. Ø16	2	40	XFC.013.5.015	FASCETTA COBRA SL030710	KOBRA CLAMP SL030710	16
4	X00.055.046R	RACCORDO CURVO P.G. Ø 14	CURVED UNION WITH R.H. D.14	6	41	XFC.015.5.017	FASCETTA COBRA SLO30720	KOBRA CLAMP	4
5	X00.226.05C	GETTO ANTIGOCCIA DIRITTO COMPLETO (0,3 bar)	COMPLETE ANTIDROP (0,3 bar)	4	42	XFC.016.5.018	FASCETTA COBRA 16,5 - 18	KOBRA CLAMP 16,5 - 18	12
6	X02.008.404C	DISTRIBUTORE LIQUIDI A 4 RUBINETTI	4 TAPS LIQUID MANIFOLD	2	43	XFC.022.5.024	FASCETTA COBRA SLO30756	KOBRA CLAMP SLO30756	2
7	X02.150.000	REGOLATORE A DISCO ROTANTE COMPLETO	ROTATION DISK REGULATION	6	44	XFC.024.5.026	FASCETTA COBRA 24,5 - 26	KOBRA CLAMP 24,5 - 26	2
8	X02.211.075	TUBO Ø16x23 L=750	HOSE Ø16x23 L=750	1	45	XOR.000.121	OR D. 15,88 x 2,62	15,88 x 2,62 O-RING GASKET	2
9	X02.211.075	TUBO Ø16x23 L=750	HOSE Ø16x23 L=750	1	46	XOR.004.081	OR Ø 20,22 x 3,53	20,22 x 3,53 O-RING GASKET	6
10	X02.212.003	TUBO Ø19x28 L=30	HOSE Ø19x28 L=30	1	47	XRP.006.000	RONDELLA PIANA D.6 6592 ZINC.	6mm D. FLAT WASHER	8
11	X02.213.007	TUBO Ø10x16 L=70	HOSE Ø10x16 L=70	2	48	XRP.010.000	RONDELLA PIANA D.10 6592 ZINC.	WASHER Ø 10	2
12	X02.213.007	TUBO Ø10x16 L=70	HOSE Ø10x16 L=70	2	49	XRP.010.030	RONDELLA PIANA F.LARGA D.10X30 ZINC.	10X30mm D. LARGE THREAD FLAT	1
13	X02.213.056	TUBO Ø10x16 L=560	HOSE Ø10x16 L=560	1	50	XTE.006.020T	VITE TE M6X20 5739 ZINC.	BOLT TE M6X20 5739	4
14	X02.213.056	TUBO Ø10x16 L=560	HOSE Ø10x16 L=560	1	51	XTE.010.060T	VITE TE UNI 5739-65 M10x60-8.8	SCREW TE UNI 5739-65 M10x60-8.8	1
15	X02.213.060	TUBO Ø10x16 L=600	HOSE Ø10x16 L=600	1					
16	X02.213.060	TUBO Ø10x16 L=600	HOSE Ø10x16 L=600	1					
17	X02.213.090	TUBO Ø10x16 L=900	HOSE Ø10x16 L=900	1					
18	X02.213.090	TUBO Ø10x16 L=900	HOSE Ø10x16 L=900	1					
19	X02.217.033	TUBO Ø8x13 L=330	HOSE Ø8x13 L=330	1					
20	X02.217.033	TUBO Ø8x13 L=330	HOSE Ø8x13 L=330	1					
21	X02.217.041	TUBO Ø8x13 L=410	HOSE Ø8x13 L=410	1					
22	X02.217.041	TUBO Ø8x13 L=410	HOSE Ø8x13 L=410	1					
23	X02.217.195	TUBO Ø8x13 L=1950	HOSE Ø8x13 L=1950	1					
24	X02.217.195	TUBO Ø8x13 L=1950	HOSE Ø8x13 L=1950	1					
25	X02.217.215	TUBO Ø8x13 L=2150	HOSE Ø8x13 L=2150	1					
26	X02.217.215	TUBO Ø8x13 L=2150	HOSE Ø8x13 L=2150	1					
27	X02.265.000	GUARNIZIONE PIANA Ø 20/30 x 2,5	PLANE GASKET Ø 20/30 X 2,5	2					
28	X02.349.000	GUARNIZIONE PIANA D.17X23X3	17X23X3 FLAT GASKET (G4000B)	8					
29	X02.380.000	NIPPLO 3/4"	NIPPLE 3/4"	4					
30	X02.396.000	RACCORDO A T 3/4" - 3/4" - 3/4" F.	UNION 3/4" - 3/4" - 3/4" F.	2					
31	X02.999.000	STAFFA FISSAGGIO RACCORDO A T	T UNION FIXING BRACKET	1					
32	X20.885.000	RACCORDO A T Ø13-13-13	T UNION Ø 13-13-13	2					
33	X21.010.000	RACCORDO P.G. DIRITTO Ø 10 COMPLETO	COMPLETE R.H. Ø 10 UNION	4					
34	X21.147.000	VALVOLA A SFERA 1/2" F/F	WAYS VALVE 1/2" F/F	2					
35	X21.151.000	RACCORDO DIRITTO PG D. 16	STRAIGHT HOSE R.H. D. 16	2					
36	XD0.06.5588G	DADO M6 6S PG 5588 ZINC.	M6 6S BIG LEAD NUT 5588	4					
37	XD0.10.5588G	DADO M10 NORMALE 5588G	NUT M10 NORMAL 5588G	2					

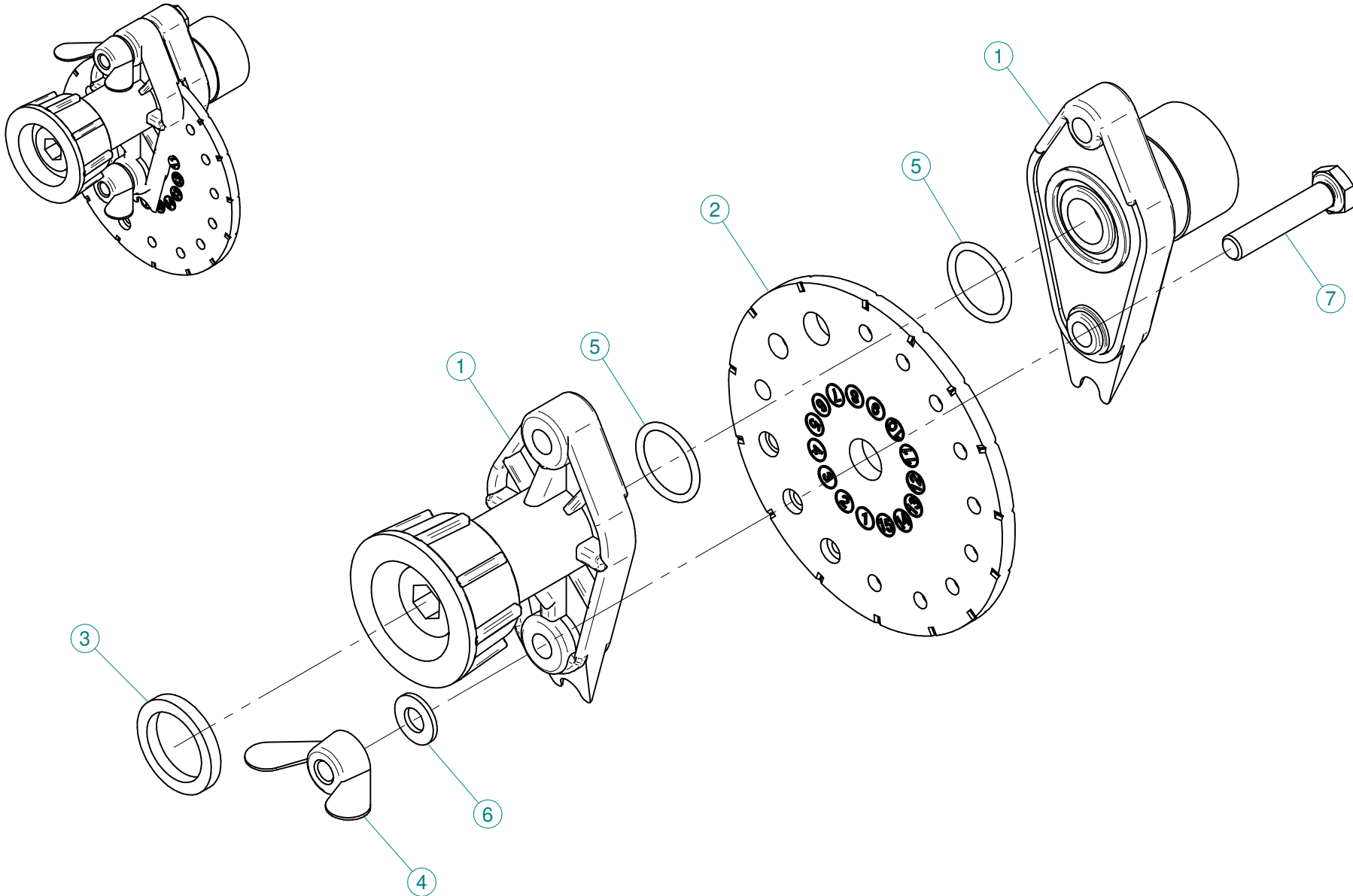

N°	Doc. Number	Titolo	Title	Q.tà
1	X02.147.500	COPPIA DI SEMICORPO REGOLATORE	REGULATOR HALF-BODY	1
2	X02.148.000	DISCO ROTANTE PER REGOLATORE	REGULATOR DISK	1
3	X02.349.000	GUARNIZIONE PIANA D.17X23X3	17X23X3 FLAT GASKET (G4000B)	1
4	XDF.OTT.006	DADO AD ALETTE IN OTTONE M6	BRASS M6 WING NUT	2
5	XOR.002.062	OR D.15,6X1,78	15.6X1.78 O-RING GASKET	2
6	XRP.006.001	RONDELLA PIANA D.6 INOX	WASHER D.6	2
7	XTE.006.030I	VITE TE M6X30 INOX 5739	BOLT TE M6X30 STAINLESS STEEL 5739	2

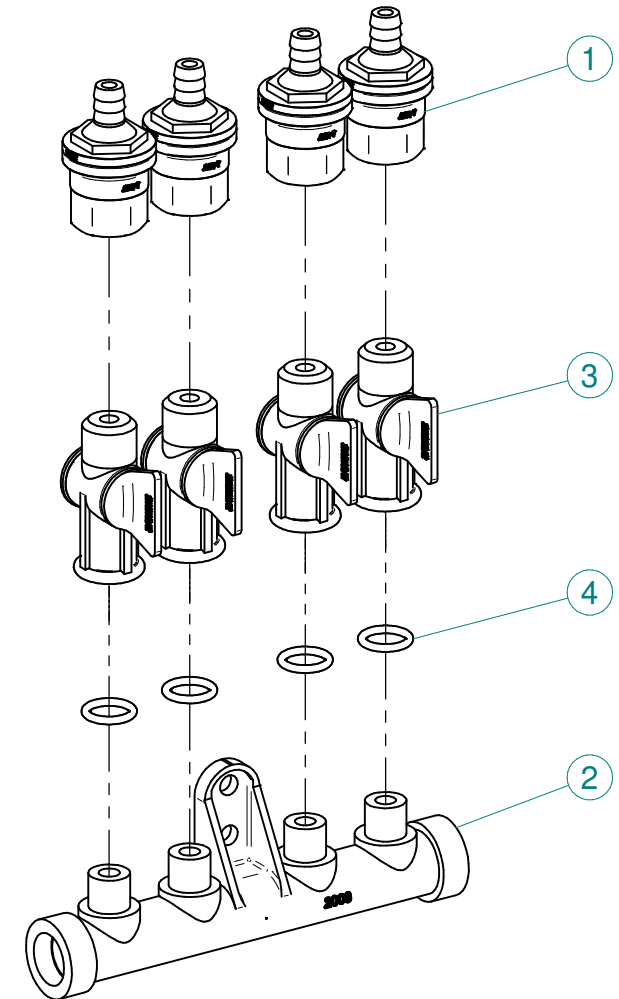
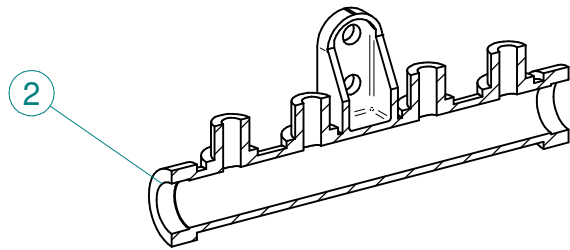

N°	Doc. Number	Titolo	Title	Q.tà
1	X00.227.01C	DISPOSITIVO ANTIGOCCIA	ANTI DRIP DEVICE	4
2	X02.008.000	DISTRIBUTORE LIQUIDO TESTATE	SPRAYHEADS LIQUID DISTRIBUTOR	1
3	X20.202.100	RUBINETTO F.1/4" M.18X1,5	TAP ASSEMBLY	4
4	XOR.000.117	OR D.13,1X2,62	13.1X2.62 O-RING GASKET	4

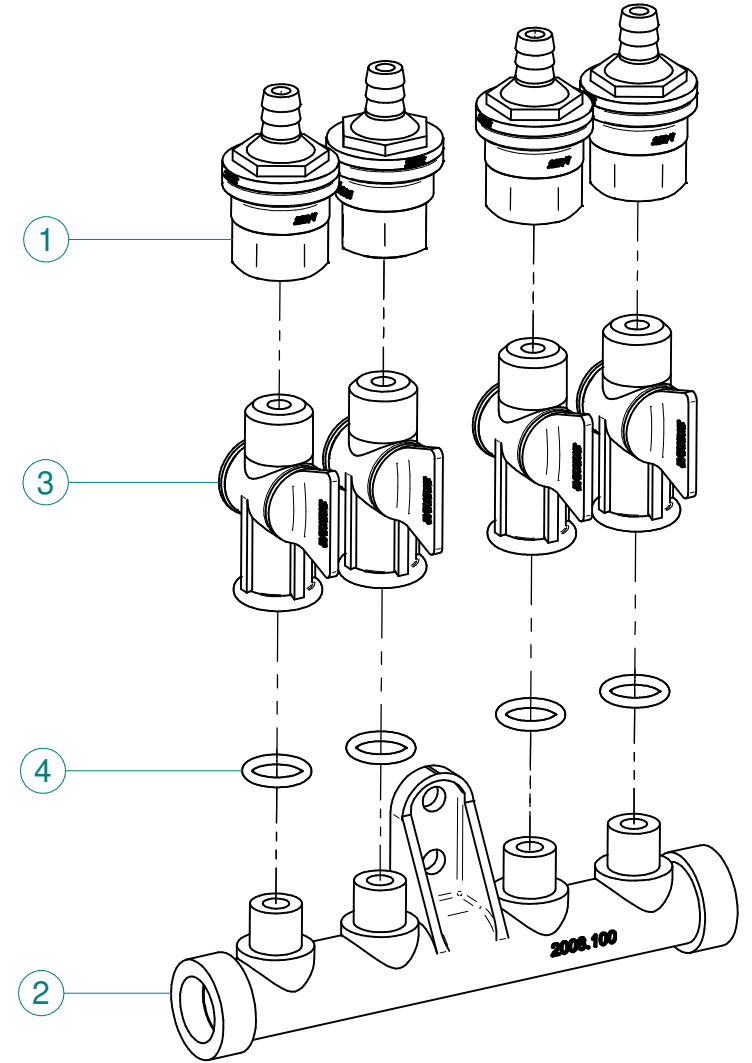
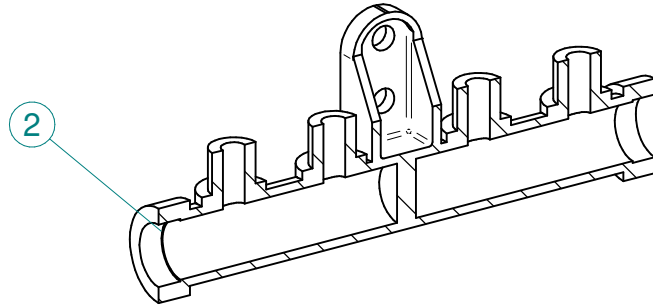

N°	Doc. Number	Titolo	Title	Q.tà
1	X00.227.01C	DISPOSITIVO ANTIGOCCIA	ANTI DRIP DEVICE	4
2	X02.008.100	DISTRIBUTORE LIQUIDO TESTATE DIVISO	SPRAYHEAD LIQUID DISTRIBUTOR	1
3	X20.202.100	RUBINETTO F.1/4" M.18X1,5	TAP ASSEMBLY	4
4	XOR.000.117	OR D.13,1X2,62	13.1X2.62 O-RING GASKET	4

Gli esplosi elencati di seguito sono relativi
a varianti o accessori a richiesta

The exploded drawings listed below are related
to different versions or optional accessories

Le vues éclatées suivantes sont relatives
à des variantes ou à des accessoires optionnels

Dibujos de vista despiezada son relativos a
variantes o accesorios opcionales

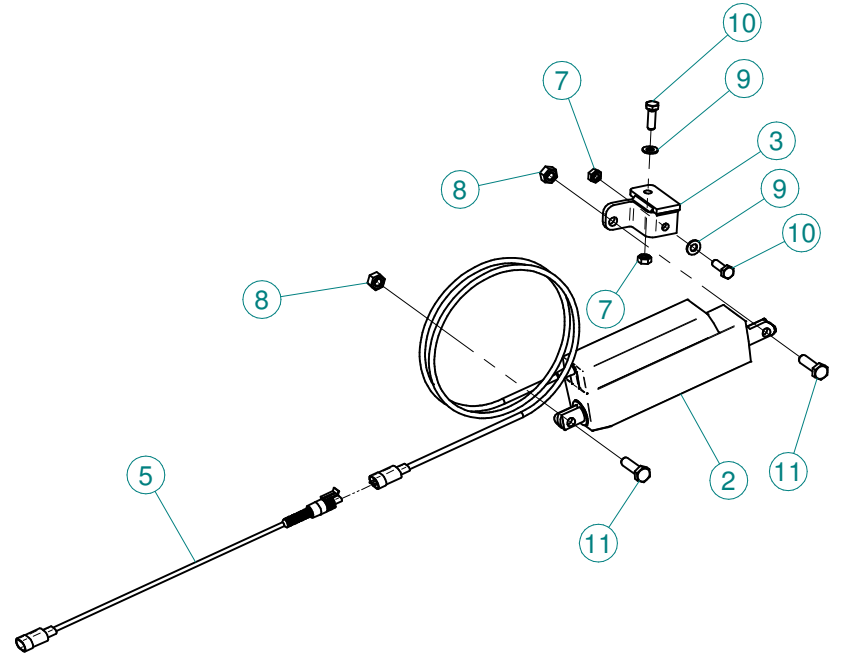
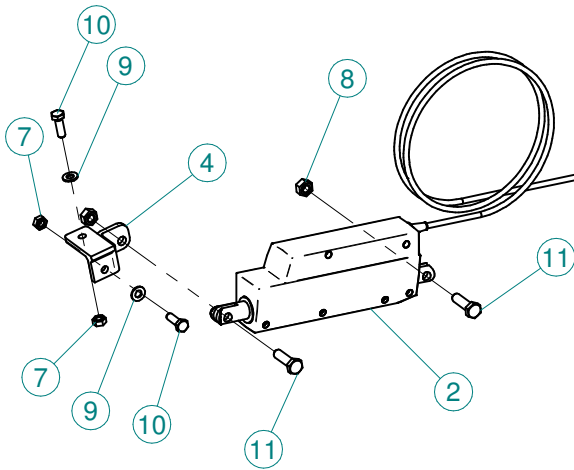
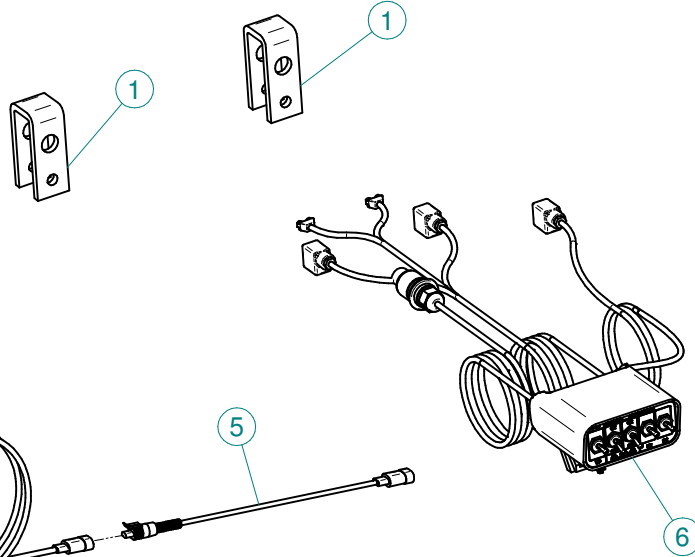
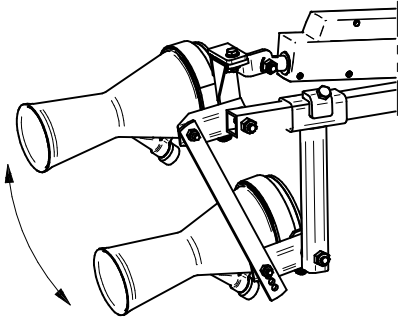

N°	Doc. Number	Titolo	Title	Q.tà
1	X20.742.206	CAVALLOTTO DI TRASCINAMENTO	U BOLT	2
2	X21.016.000	ATTUATORE LINEARE (LA 12.1)	LINEAR ACTUATOR (LA 12.1)	2
3	X21.174.000	STAFFETTA ATTACCO ATTUATORE LINEARE	ACTUATOR BRACKET	1
4	X21.175.000	STAFFETTA ATTACCO ATTUATORE LINEARE	ACTUATOR BRACKET	1
5	X21.474.100	CAVO L=3000 mm COLLEGAMENTO ATTUATORI ELETTRICI	CABLE L=3000 mm ACTUATORS CONNECTION	2
6	X21.530.200	KIT COMANDO ELETTRICO PER PLUS LINK	CONTROL BOX ASSEMBLY FOR PLUS - LINK	1
7	XD0.08.5588G	DADO M8 6S PG 5588 ZINC.	M8 6S BIG LEAD NUT 5588	4
8	XD0.10.5587G	DADO M10 6S PG 5587 ZINC.	M10 6S BIG LEAD NUT 5587	4
9	XRP.008.000	RONDELLA PIANA D.8 6592 ZINC.	8 D. FLAT WASHER	4
10	XTE.008.025T	VITE TE M8X25	BOLT TE M8X25	4
11	XTE.010.035T	VITE TE UNI 5739-65 M10x35-8.8	SCREW TE UNI 5739-65 M10x35-8.8	4

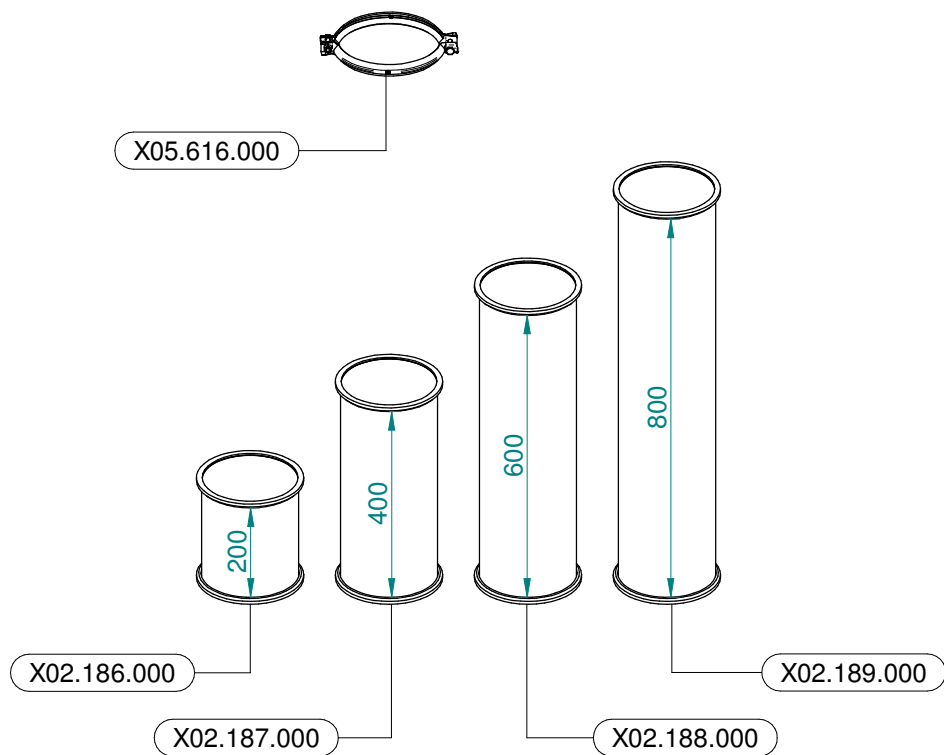

Ø 175
 Plus 42 - 45 - 50
 Blitz 45 - 50
 Link 50

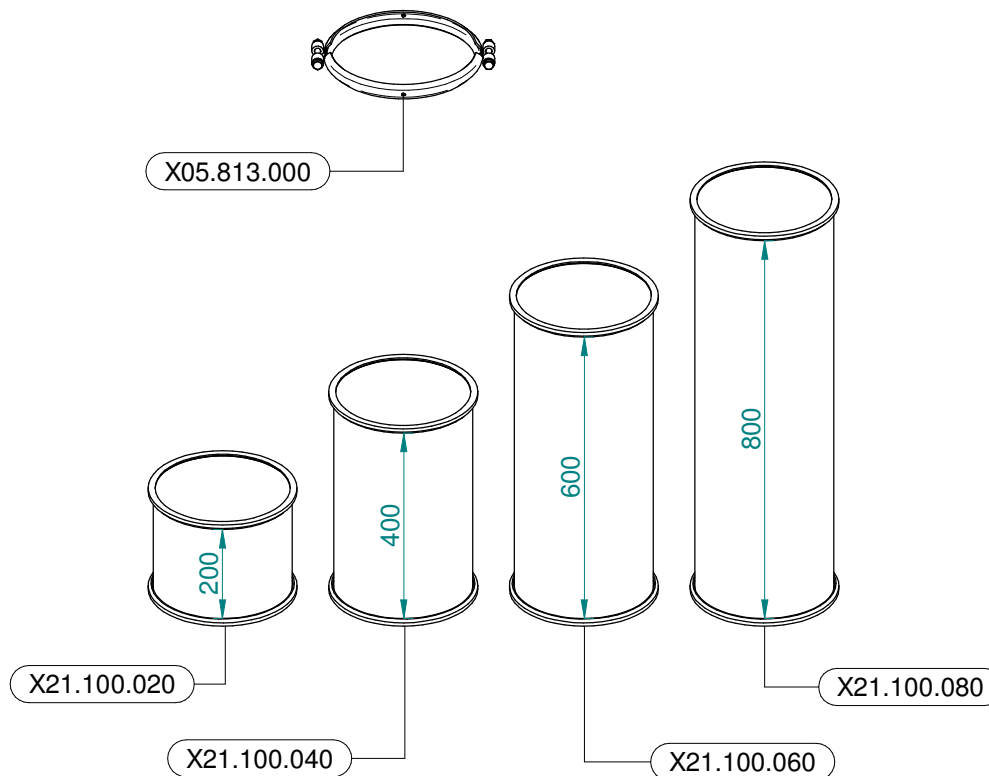

Ø 250
 Plus 55
 Blitz 55
 Link 55