

Sez. T01
Telaio
Frame

Sez. T03
Percordo aria
Air duct

Sez. T06
Percorso liquido
Plumbing of liquids

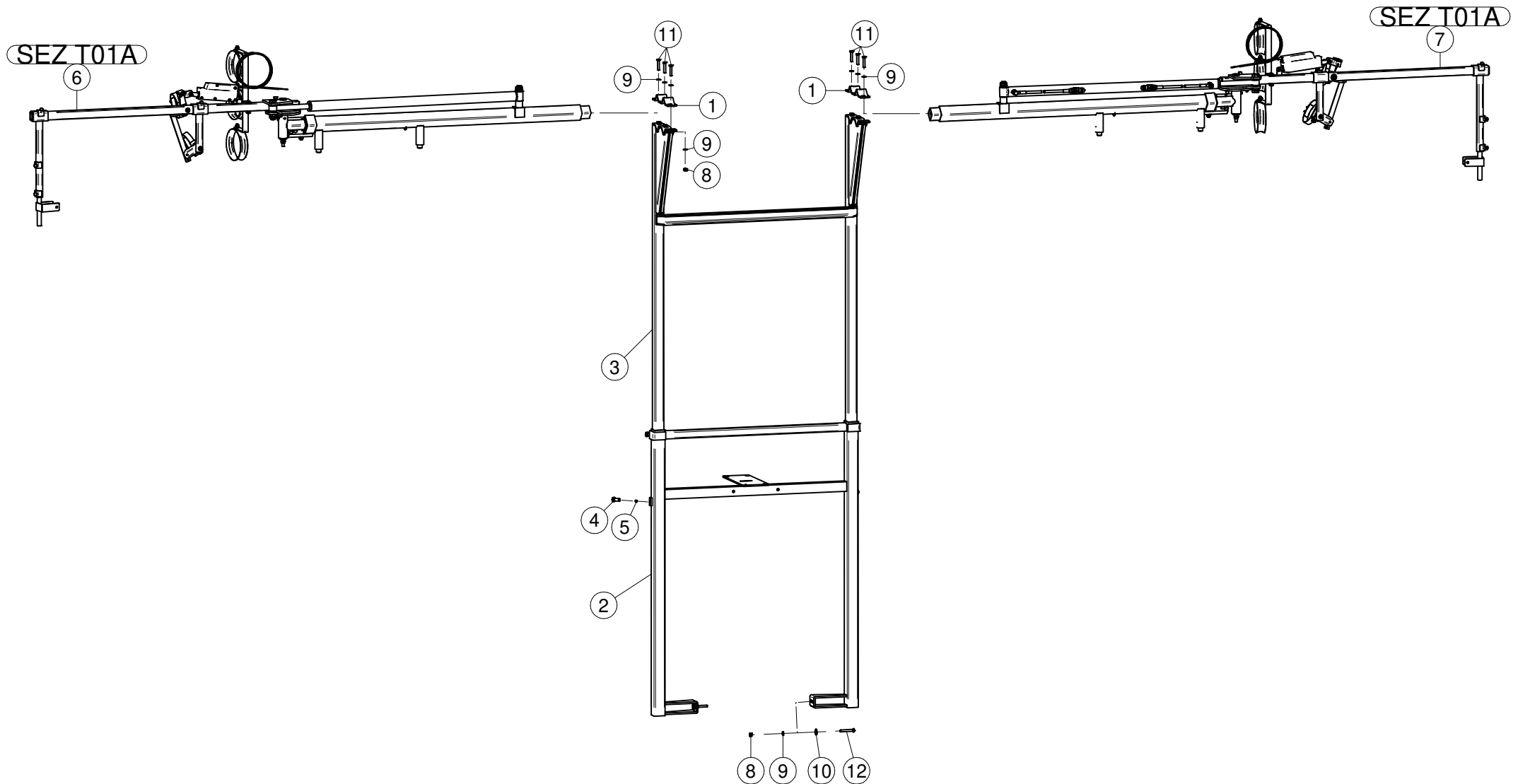

N°	Doc. Number	Titolo	Title	Q.tà
1	X20.742.015	GUIDA BRACCI SCORREVOLE	SLIDING ARMS GUIDE	2
2	X20.742.401	TELAIO CENTRALE FISSO	CENTRAL FRAME	1
3	X20.742.502	TELAIO CENTRALE SCORREVOLE	SLIDING FRAME	1
4	X21.312.000	VITE TE M14x30 CON FORO Ø10	SCREW TE M14x30 WITH HOLE Ø10	4
5	X21.313.000	TONDINO PER VITE DI BLOCCAGGIO M14	ROD FOR LOCKING SCREW	4
6	X21.509.000	BRACCIO LATERALE DESTRO	RIGHT ARM	1
7	X21.510.000	BRACCIO LATERALE SINISTRO	LEFT ARM	1
8	XD0.10.5587G	DADO M10 6S PG 5587 ZINC.	M10 6S BIG LEAD NUT 5587	6
9	XRP.010.000	RONDELLA PIANA D.10 6592 ZINC.	WASHER Ø 10	12
10	XRP.010.030	RONDELLA PIANA F.LARGA D.10X30 ZINC.	10X30mm D. LARGE THREAD FLAT	2
11	XTE.010.050T	VITE TE M10X50 5739 ZINC.	BOLT TE M10X50 5739	6
12	XTE.010.070T	VITE TE UNI 5739-65 M10x70-8.8	SCREW TE UNI 5739-65 M10x70-8.8	2

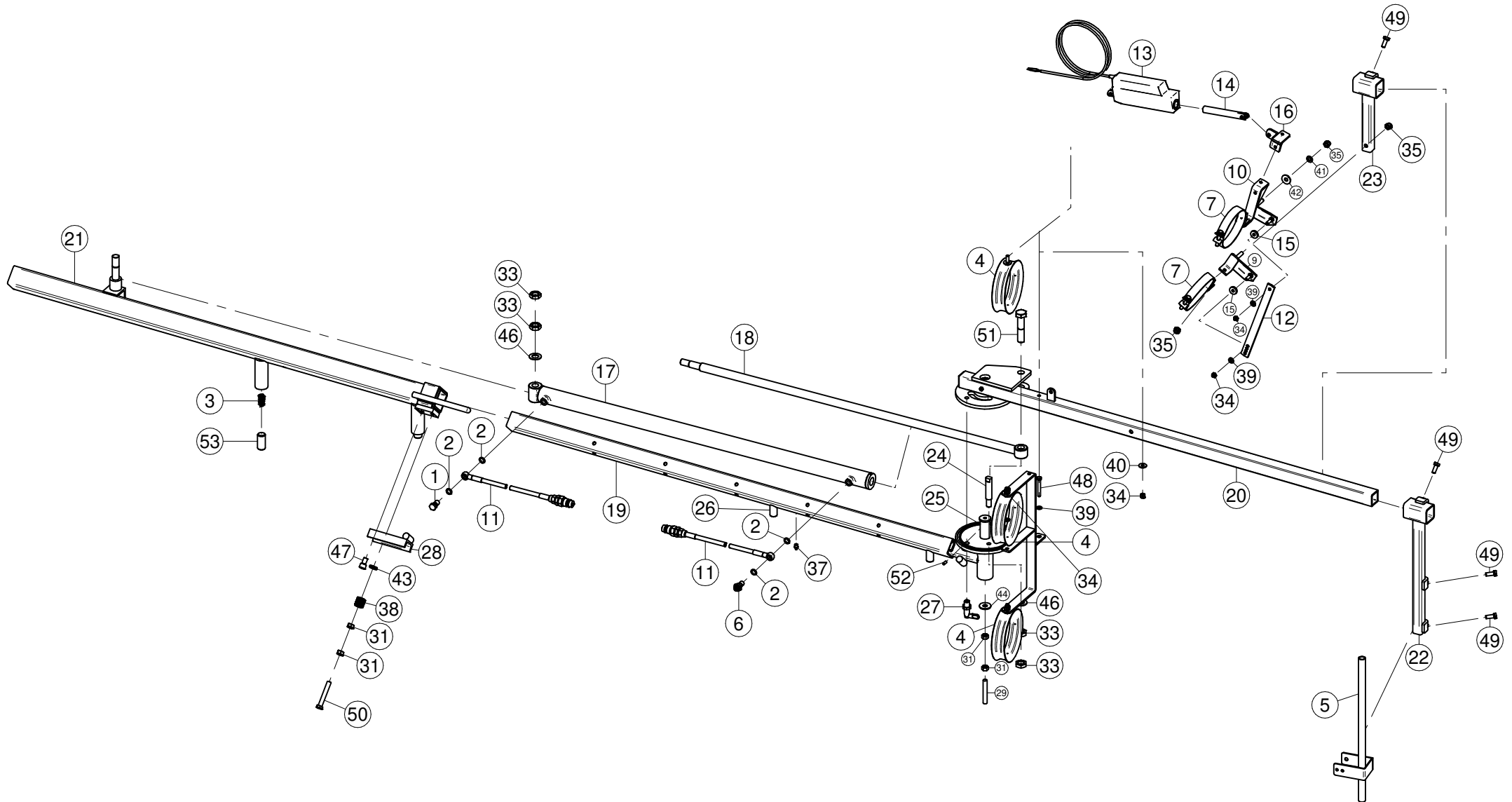

N°	Doc. Number	Titolo	Title	Q.tà
1	X02.408.000	RACCORDO DRITTO PER OCCHIO 1/4"	JACK EYE RIGHT UNION 1/4"	1
2	X02.472.000	RONDELLA DI RAME Ø 19x13,5x1,5	COPPER WASHER Ø 19x13,5x1,5	4
3	X07.556.000	MOLLA D.INT..12,5 x F.3,5 x L=60	SPRING	2
4	X20.227.000	ANELLO GUIDA TUBI PICCOLO	SMALL PIPE GUIDE RING	3
5*	X20.678.001	BRACCIO FISSAGGIO DIFFUSORE SINISTRO	LEFT NOZZLE FIXING ARM	1
6	X20.718.000	REGOLATORE PORTATA IDRAULICA 1/4"	FLOW REGULATOR 1/4"	1
7	X20.742.018	ATTACCO ANELLO PICCOLO	SMALL RING ATTACH	2
8*	X20.742.108	ATTACCO ANELLI PASSATUBO	RING ATTACH	1
9	X20.742.110DX	ATTACCO ANELLO PICCOLO	SMALL RING ATTACH	1
10	X20.742.124DX	ATTACCO ANELLO PICCOLO	SMALL RING ATTACH	1
11	X20.900.680	TUBO OLIO PER MARTINETTO L=6800	OIL PIPE FOR JACK L=6800	2
12	X20.922.000	STAFFA COLLEGAMENTO PER DIFF.MOVIM. IDRAULICA	UNION BRACKET	1
13	X21.016.000	ATTUATORE LINEARE (LA 12.1)	LINEAR ACTUATOR (LA 12.1)	1
14	X21.016.002	STELO ATTUATORE LINEARE	LINEAR ACTUATOR STEM	1
15	X21.028.000	DISTANZIALE	SPACER	2
16	X21.174.001	STAFFETTA ATTACCO ATTUATORE LINEARE	ACTUATOR BRACKET	1
17	X21.505.000.A	PISTONE	PISTON	1
18	X21.505.000.B	STELO CENTRALE	CENTRAL STEM	1
19	X21.511.000	BRACCIO LATERALE DESTRO SCORREVOLE	SLIDING RIGHT SIDE ARM	1
20	X21.513.000	BRACCIO LATERALE DESTRO RIPIEGABILE	TURNING RIGHT SIDE ARM	1
21	X21.515.000	BRACCIO LATERALE DESTRO FISSO	FIXING RIGHT SIDE ARM	1
22	X21.518.000	PORTA PALO DI DISCESA SCORREVOLE DESTRO	RIGHT SLIDING DESCENT DOOR HOLDER	1
23	X21.520.000	ATTACCO ANELLI PORTADIFFUSORI	SMALL RING ATTACH	1
24	X21.527.000	PERNO M14	PIN M14	1
25	X21.528.000	PERNO PER BRACCIO	PIN FOR ARM	1
26	X21.529.000	GUIDABRACCIO IN OTTONE	BRASS ARM GUIDE	2
27	X21.531.000	PERNO A SCATTO	SNAP PIN	1
28	X21.532.000	BASCULANTE CON TONDO	TILTING WITH ROUND	1
29	XBRF.012.008	BARRA FILETTATA M12 L=80	PIPE M12 L=80	1
32	XD0.08.5588G	DADO M8 6S PG	M8 6S BIG LEAD NUT 5588	1
31	XD0.12.5587G	DADO M12 6S PG 5587 ZINC.	M12 6S BIG LEAD NUT 5587	4
34	XD0.14.5587G	DADO M14 6S PG 5587 ZINC.	M14 6S BIG LEAD NUT 5587	1
33	XD0.20.5589G	DADO BASSO M20	LOWER NUT M20	4
34	XDA.008.0AG	DADO AUTOBLOCCANTE M8 ALTO PG ZINC.	HIGH BIG LEAD M8 SELFLOCKING	6
35	XDA.010.0BG	DADO AUTOBLOCCANTE M10	SELF LOCKING NUT M10	4
36	XID.006.001	INGRASSATORE DIRITTO M6	GREASER	2
37	XID.010.001	INGRASSATORE DIRITTO M 10X1 ZINC.	STRAIGHT GREASE NIPPLE	1
38	XMT.012.000	MOLLA A DI BELLEVILLE Di 12.2 De 25	BELLEVILLE SPRING Di 12.2 De 25	24
39	XRP.008.000	RONDELLA PIANA D.8 6592 ZINC.	8 D. FLAT WASHER	6
40	XRP.008.024	RONDELLA PIANA F.LARGA D.8X24 ZINC.	WASHER D.8X24	3
41	XRP.010.000	RONDELLA PIANA D.10 6592 ZINC.	WASHER Ø 10	2
42	XRP.010.030	RONDELLA PIANA F.LARGA D.10X30 ZINC.	10X30mm D. LARGE THREAD FLAT	1
43	XRP.012.000	RONDELLA PIANA Ø12	WASHER Ø12	2
44	XRP.012.036	RONDELLA PIANA D12 X 36	WASHER D12 X 36	2
46	XRP.014.000	RONDELLA PIANA Ø14	WASHER Ø14	1
46	XRP.020.000	RONDELLA PIANA D.20	WASHER D.20	2
47	XTCE.012.020	VITE BRUGOLA TCE M12 X 20	BOLT M12 X 20	1
48	XTE.008.060T	VITE TE UNI 5739-65 M8x60-8.8	SCREW TE UNI 5739-65 M8x60-8.8	1
49	XTE.010.025	VITE TE UNI 5737-65 M10x25-8.8	SCREW TE UNI 5737-65 M10x25-8.8	4
50	XTE.012.080T	VITE TE UNI 5739-65 M12x80-8.8	SCREW TE UNI 5739-65 M12x80-8.8	1
51	XTE.020.080	VITE TE UNI 5737-65 M20x80-8.8	SCREW TE UNI 5737-65 M20x80-8.8	1
52	XVCE.06.16.23	GRANO FILETTATO M6x16	DOWEL	1
53	XVCE.24.50.23	GRANO M24 x 50	DOWEL M24 x 50	2

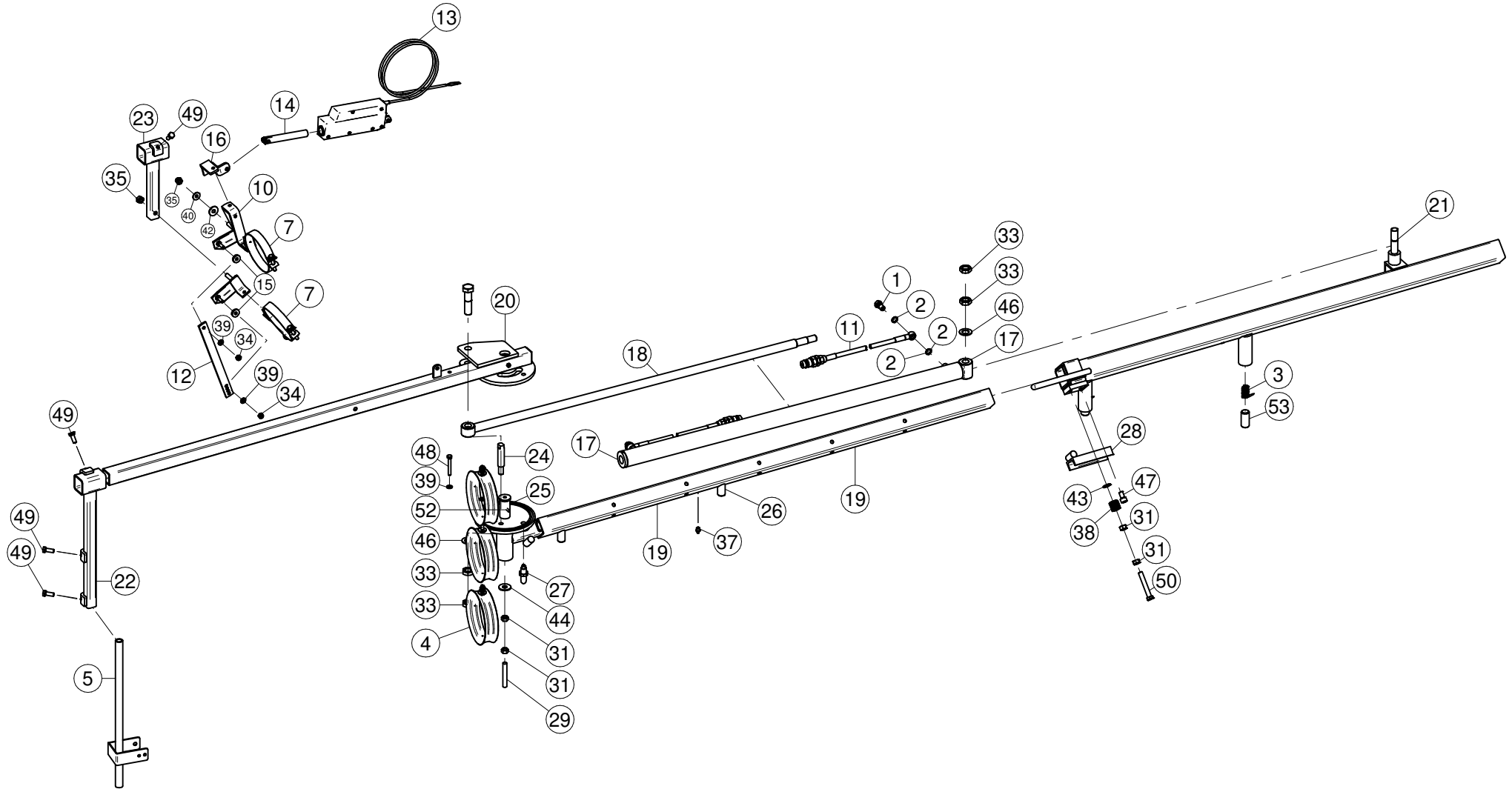

N°	Doc. Number	Titolo	Title	Q.tà
1	X02.408.000	RACCORDO DRITTO PER OCCHIO 1/4"	JACK EYE RIGHT UNION 1/4"	1
2	X02.472.000	RONDELLA DI RAME Ø 19x13,5x1,5	COPPER WASHER Ø 19x13,5x1,5	4
3	X07.556.000	MOLLA D.INT..12,5 x F.3,5 x L=60	SPRING	2
4	X20.227.000	ANELLO GUIDA TUBI PICCOLO	SMALL PIPE GUIDE RING	3
5	X20.678.101	BRACCIO FISSAGGIO MANO DESTRA	RIGHT FIXING ARM	1
6	X20.718.000	REGOLATORE PORTATA IDRAULICA 1/4"	FLOW REGULATOR 1/4"	1
7	X20.742.018	ATTACCO ANELLO PICCOLO	SMALL RING ATTACH	2
8	X20.742.108	ATTACCO ANELLI PASSATUBO	RING ATTACH	1
9	X20.742.110SX	ATTACCO ANELLO PICCOLO	SMALL RING ATTACH	1
10	X20.742.124SX	ATTACCO ANELLO PICCOLO	SMALL RING ATTACH	1
11	X20.900.680	TUBO OLIO PER MARTINETTO L=6800	OIL PIPE FOR JACK L=6800	2
12	X20.922.000	STAFFA COLLEGAMENTO PER DIFF.MOVIM. IDRAULICA	UNION BRACKET	1
13	X21.016.000	ATTUATORE LINEARE (LA 12.1)	LINEAR ACTUATOR (LA 12.1)	1
14	X21.016.002	STELO ATTUATORE LINEARE	LINEAR ACTUATOR STEM	1
15	X21.028.000	DISTANZIALE	SPACER	2
16	X21.174.001	STAFFETTA ATTACCO ATTUATORE LINEARE	ACTUATOR BRACKET	1
17	X21.505.000.A	PISTONE	PISTON	1
18	X21.505.000.B	STELO CENTRALE	CENTRAL STEM	1
19	X21.512.000	BRACCIO LATERALE SINISTRO SCORREVOLE	SLIDING LEFT SIDE ARM	1
20	X21.514.000	BRACCIO LATERALE SINISTRO RIPIEGABILE	TURNING LEFT SIDE ARM	1
21	X21.516.000	BRACCIO LATERALE SINISTRO FISSO	FIXING LEFT SIDE ARM	1
22	X21.519.100	PORTA PALO DI DISCESA SCORREVOLE SINISTRO		1
23	X21.520.000	ATTACCO ANELLI PORTADIFFUSORI	SMALL RING ATTACH	1
24	X21.527.000	PERNO M14	PIN M14	1
25	X21.528.000	PERNO PER BRACCIO	PIN FOR ARM	1
26	X21.529.000	GUIDABRACCIO IN OTTONE	BRASS ARM GUIDE	2
27	X21.531.000	PERNO A SCATTO	SNAP PIN	1
28	X21.532.000	BASCULANTE CON TONDO	TILTING WITH ROUND	1
29	XBRF.012.008	BARRA FILETTATA M12 L=80	PIPE M12 L=80	1
30	XD0.08.5588G	DADO M8 6S PG	M8 6S BIG LEAD NUT 5588	1
31	XD0.12.5587G	DADO M12 6S PG 5587 ZINC.	M12 6S BIG LEAD NUT 5587	4
32	XD0.14.5587G	DADO M14 6S PG 5587 ZINC.	M14 6S BIG LEAD NUT 5587	1
33	XD0.20.5589G	DADO BASSO M20	LOWER NUT M20	4
34	XDA.008.0AG	DADO AUTOBLOCCANTE M8 ALTO PG ZINC.	HIGH BIG LEAD M8 SELFLOCKING	6
35	XDA.010.0BG	DADO AUTOBLOCCANTE M10	SELF LOCKING NUT M10	4
36	XID.006.001	INGRASSATORE DIRITTO M6	GREASER	2
37	XID.010.001	INGRASSATORE DIRITTO M 10X1 ZINC.	STRAIGHT GREASE NIPPLE	1
38	XMT.012.000	MOLLA A DI BELLEVILLE Di 12.2 De 25	BELLEVILLE SPRING Di 12.2 De 25	24
39	XRP.008.000	RONDELLA PIANA D.8 6592 ZINC.	8 D. FLAT WASHER	6
40	XRP.008.024	RONDELLA PIANA F.LARGA D.8X24 ZINC.	WASHER D.8X24	3
40	XRP.010.000	RONDELLA PIANA D.10 6592 ZINC.	WASHER Ø 10	2
42	XRP.010.030	RONDELLA PIANA F.LARGA D.10X30 ZINC.	10X30mm D. LARGE THREAD FLAT	1
43	XRP.012.000	RONDELLA PIANA Ø12	WASHER Ø12	2
44	XRP.012.036	RONDELLA PIANA D12 X 36	WASHER D12 X 36	2
44	XRP.014.000	RONDELLA PIANA Ø14	WASHER Ø14	1
46	XRP.020.000	RONDELLA PIANA D.20	WASHER D.20	2
47	XTCE.012.020	VITE BRUGOLA TCE M12 X 20	BOLT M12 X 20	1
48	XTE.008.060T	VITE TE UNI 5739-65 M8x60-8.8	SCREW TE UNI 5739-65 M8x60-8.8	1
49	XTE.010.025	VITE TE UNI 5737-65 M10x25-8.8	SCREW TE UNI 5737-65 M10x25-8.8	4
50	XTE.012.080T	VITE TE UNI 5739-65 M12x80-8.8	SCREW TE UNI 5739-65 M12x80-8.8	1
51	XTE.020.080	VITE TE UNI 5737-65 M20x80-8.8	SCREW TE UNI 5737-65 M20x80-8.8	1
52	XVCE.06.16.23	GRANO FILETTATO M6x16	DOWEL	1
53	XVCE.24.50.23	GRANO M24 x 50	DOWEL M24 x 50	2

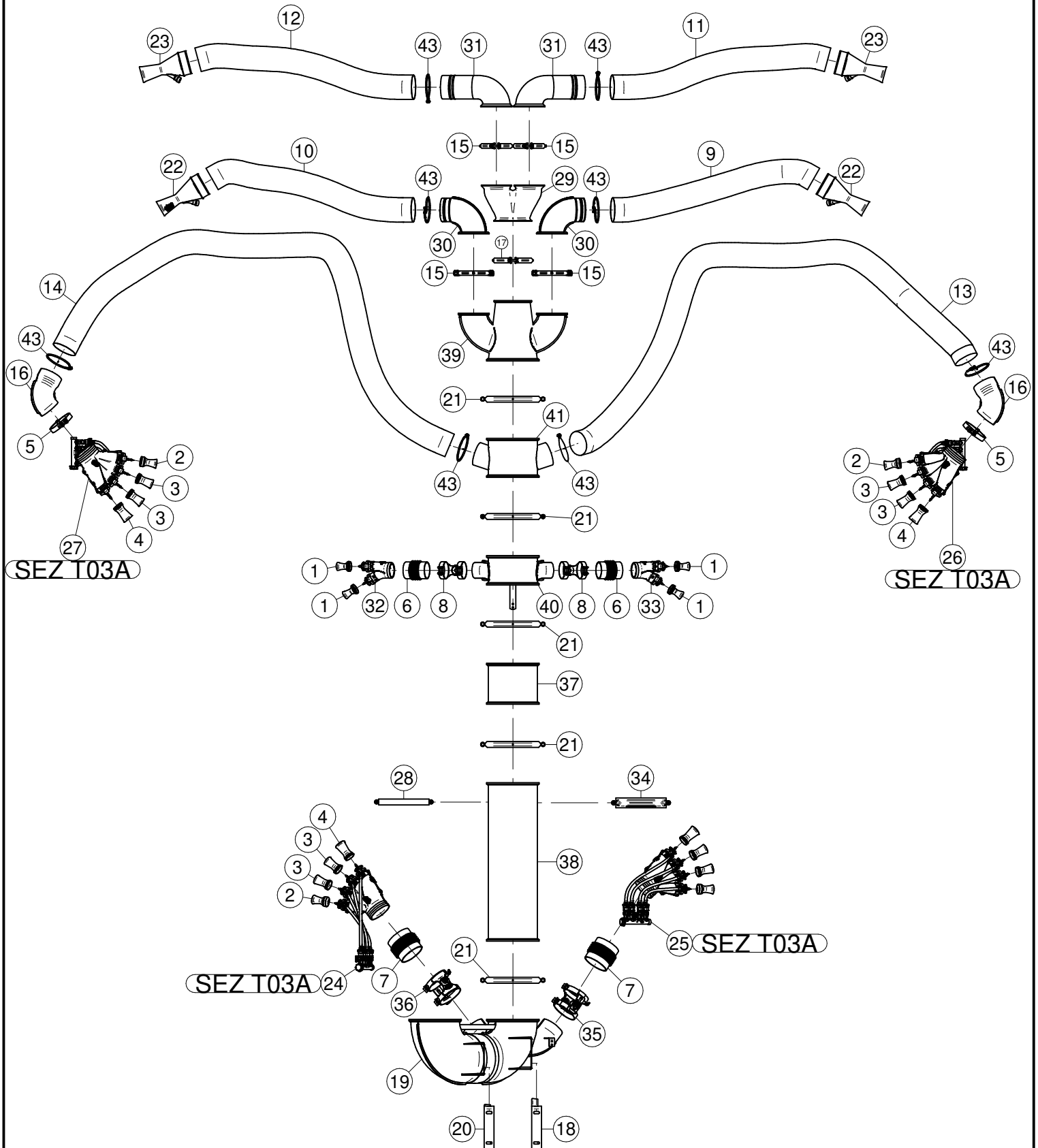

N°	Doc. Number	Titolo	Title	Q.tà
1	X00.003,5.50	DIFFUSORE 3,5/50	NOZZLE 3,5/50	4
2	X00.004,5.50	DIFFUSORE 4,5/50	NOZZLE 4,5/50	4
3	X00.006.050	DIFFUSORE 6/50	NOZZLE 6/50	8
4	X00.008.050	DIFFUSORE 8/50	NOZZLE 8/50	4
5	X00.125.001	FEMMINA FASCETTA D.125 ORIENTABILE	FEMALE CLAMP D.125	2
6	X02.020.000	MANICOTTO FLESSIBILE Ø 80 x 115	FLEXIBLE SLEEVE Ø 80 x 115	2
7	X02.021.000	MANICOTTO FLESSIBILE D.120X120	120 D. FLEXIBLE SLEEVE	2
8	X02.046.000	COPPIA FASCETTE Ø 85	CLAMP Ø 85	2
9	X02.239.190	TUBO SPIRALATO Ø120 L=1900	HOSE Ø120 L=1900	1
10	X02.239.190	TUBO SPIRALATO Ø120 L=1900	HOSE Ø120 L=1900	1
11	X02.239.205	TUBO SPIRALATO Ø120 L=2050	HOSE Ø120 L=2050	1
12	X02.239.205	TUBO SPIRALATO Ø120 L=2050	HOSE Ø120 L=2050	1
13	X02.239.370	TUBO SPIRALATO Ø120 L=3700	HOSE Ø120 L=3700	1
14	X02.239.370	TUBO SPIRALATO Ø120 L=3700	HOSE Ø120 L=3700	1
15	X04.027.000	COLLARE PER TUBI D. 150	PIPE CLAMP D. 150	4
16	X04.845.900	CURVA D.120 A 105°	ELBOW D.120 A 105°	2
17	X05.616.000	COLLARE PER TUBI Ø 175	PIPE CLAMP Ø 175	1
18	X05.802.051	STAFFA FISSAGGIO CURVA D.250 A 180°	ELBOW FIXING BRACKET	1
19	X05.802.100	CURVA Ø250 A 180° CON 2 USCITE Ø120	ELBOW Ø250 180° WITH 2 OUTLETS Ø120	1
20	X05.802.151	STAFFA FISSAGGIO CURVA D.250 A 180°	ELBOW FIXING BRACKET	1
21	X05.813.000	COLLARE Ø275	CLAMP Ø275	5
22	X10.014.120	DIFFUSORE 14/120	CANNON 14/120	2
23	X10.018.120	DIFFUSORE 18/120 CON TUBETTO	NOZZLE 18/120	2
24	X20.014.404CDX	MANO A 4 USCITE COMPLETA DI DISTRIBUZIONE	FOUR NOZZLES DIFFUSER	1
25	X20.014.404CSX	MANO A 4 USCITE COMPLETA DI DISTRIBUZIONE	FOUR NOZZLES DIFFUSER	1
26	X20.014.504CDX	MANO A 4 USCITE COMPLETA DI DISTRIBUTORE	FOUR NOZZLES DIFFUSER	1
27	X20.014.504CSX	MANO A 4 USCITE COMPLETA DI DISTRIBUTORE	FOUR NOZZLES DIFFUSER	1
28	X20.091.000	FASCETTA D.250 PER FISSAGGIO P.L.	CLAMP D.250 FOR FIXING	1
29	X20.204.003	CORPO A Y D.175 IN P.E.	Y BODY IN P.E.	1
30	X20.205.020	CURVA D.120 L=170 PER TC	ELBOW D.120 L=170 PER TC	2
31	X20.205.030	CURVA D.120 L=290 PER TC IN POLIETILENE	ELBOW D.120 L=290 FOR TC	2
32	X20.221.100DX	MANO Ø 80 A DUE USCITE	TWO OUTLETS BODY	1
33	X20.221.100SX	MANO Ø 80 A DUE USCITE	TWO OUTLETS BODY	1
34	X20.504.000	FASCETTA Ø250 FISSAGGIO TESTATE	Ø250 CLAMP HEADS FIXING	1
35	X21.080.000	COPPIA FASCETTE Ø 127 DESTRA	RIGHT CLAMP Ø 127	1
36	X21.081.000	COPPIA FASCETTE Ø 127 SINISTRA	LEFT CLAMP Ø 127	1
37	X21.100.020	PROLUNGA D.250 x 200	EXTENSION D.250 x 200	1
38	X21.100.080	PROLUNGA D.250 X 800 MM.	250mm INTERNAL D.800mm LENGTH	1
39	X50.078.000	CORPO D.250-175 CON DUE USCITE D.130	BODY D.250-175 WITH 2 OUTLETS D.130	1
40	X50.081.000	CORPO ø250 L=150 CON 2 USCITE ø80	BODY ø250 L=150 WITH 2 OUTLETS ø80	1
41	X50.313.000	CORPO D.250 CON DUE USCITE D.120	BODY D.250 WITH 2 OUTLETS D.120	1
42	XDA.010.0BG	DADO AUTOBLOCCANTE M10	SELF LOCKING NUT M10	1
43	XF0.120.000	FASCETTA UNIFILO D.120	CLAMP D.120	8
44	XRP.010.030	RONDELLA PIANA F.LARGA D.10X30 ZINC.	10X30mm D. LARGE THREAD FLAT	1

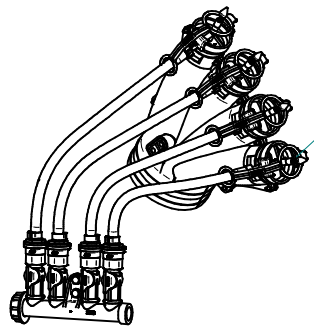

X20.014.404CSX

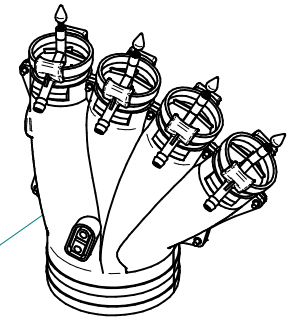

X20.014.000SX

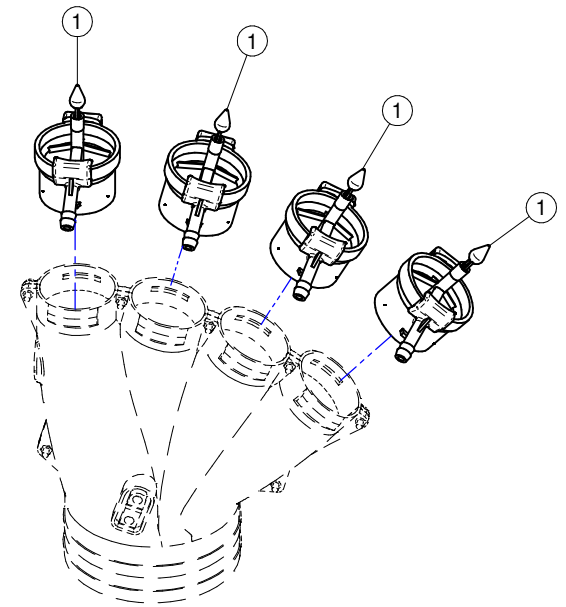
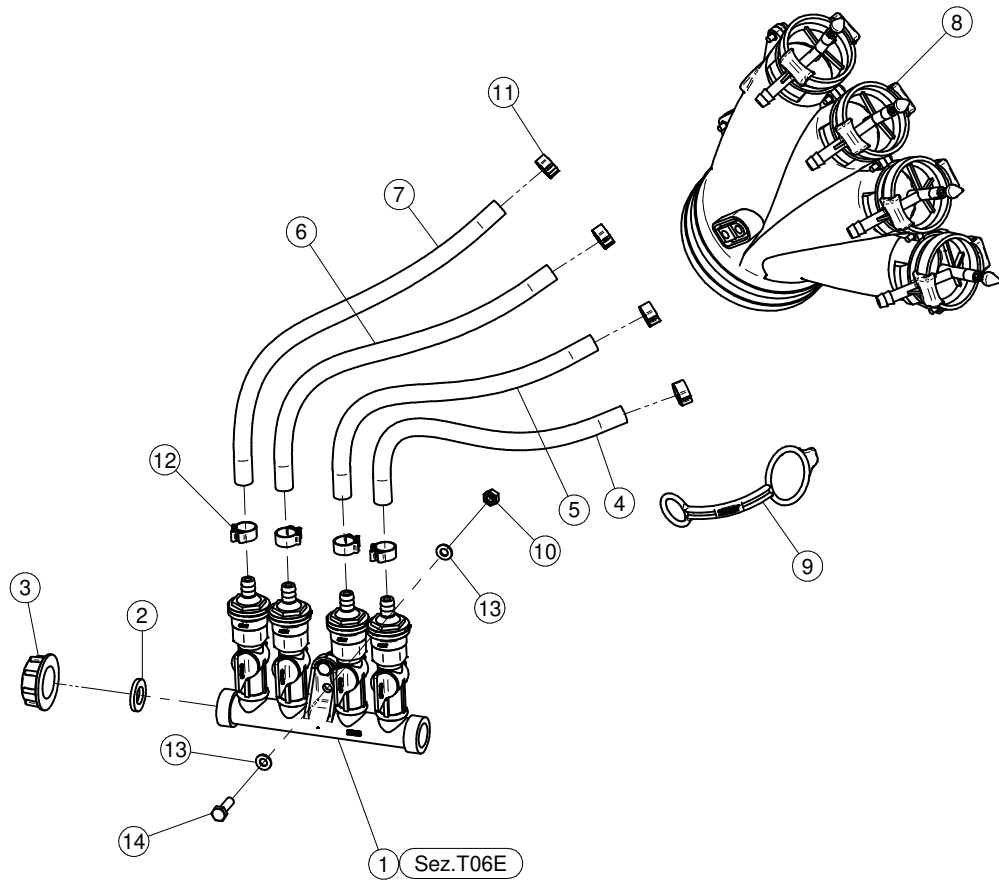

X20.014.404CSX

N°	Doc. Number	Titolo	Title	Q.tà
1	X02.008.304C	DISTRIBUTORE LIQUIDI A 4 RUBINETTI CON ANTIGOCCIA	FOUR TAPS LIQUID DISTRIBUTOR WITH ANTI-DRIP DEVICE	1
2	X02.030.010	GUARNIZIONE IN GOMMA D.24X13X3	GASKET D.24X13X3	1
3	X02.182.000	TAPPO 3/4" F.	FEMALE 3/4" CAP	1
4	X02.217.029	TUBO Ø8x13 L=290	HOSE Ø8x13 L=290	1
5	X02.217.033	TUBO Ø8x13 L=330	HOSE Ø8x13 L=330	1
6	X02.217.038	TUBO Ø8x13 L=380	HOSE Ø8x13 L=380	1
7	X02.217.041	TUBO Ø8x13 L=410	HOSE Ø8x13 L=410	1
8	X20.014.000SX	MANO A 4 USCITE CON TUBETTI	FOUR OUTLETS	1
9	X20.697.000	FERMA DIFFUSORI	NOZZLE STOP	4
10	XD0.06.5588G	DADO M6 6S PG 5588 ZINC.	M6 6S BIG LEAD NUT 5588	2
11	XFC.012,5.014	FASCETTA COBRA SL030705	KOBRA CLAMP SL030705	4
12	XFC.013,5.015	FASCETTA COBRA SL030710	KOBRA CLAMP SL030710	4
13	XRP.006.000	RONDELLA PIANA D.6 6592 ZINC.	6mm D. FLAT WASHER	4
14	XTE.006.020T	VITE TE M6X20 5739 ZINC.	BOLT TE M6X20 5739	2

X20.014.000SX

N°	Doc. Number	Titolo	Title	Q.tà
1	X20.016.01C	RACCORDO ATTACCO RAPIDO PORTA TUBETTO	PIPE WITH OLIVE	4

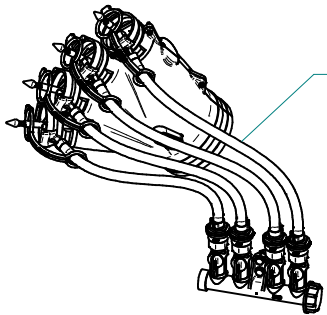

X20.014.404CDX

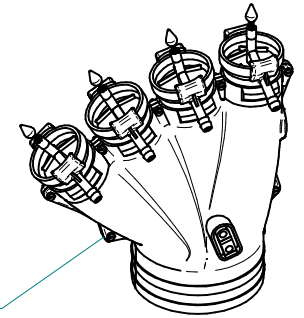

X20.014.000DX

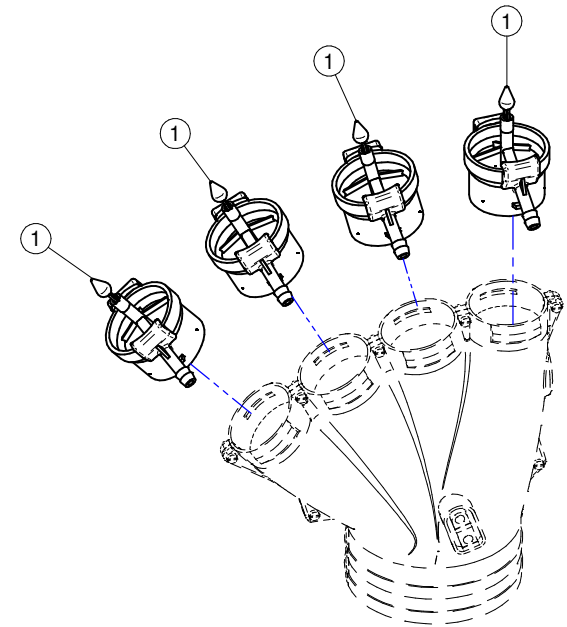
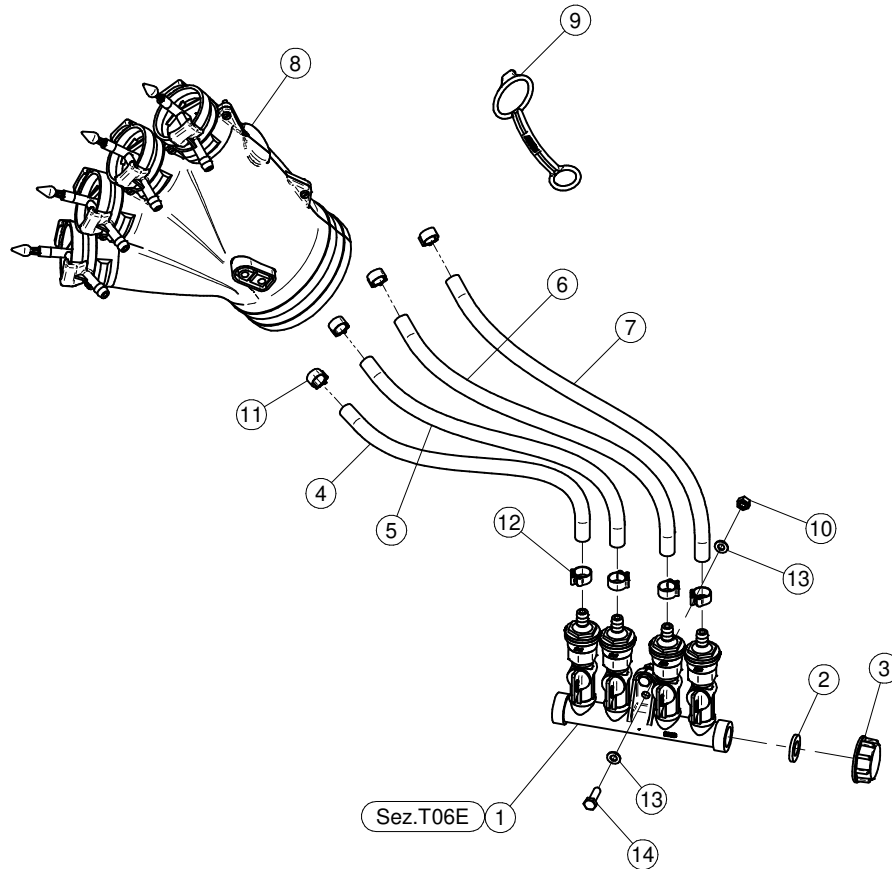

X20.014.404CDX

N°	Doc. Number	Titolo	Title	Q.tà
1	X02.008.304C	DISTRIBUTORE LIQUIDI A 4 RUBINETTI CON ANTIGOCCIA	FOUR TAPS LIQUID DISTRIBUTOR WITH ANTI-DRIP DEVICE	1
2	X02.030.010	GUARNIZIONE IN GOMMA D.24X13X3	GASKET D.24X13X3	1
3	X02.182.000	TAPPO 3/4" F.	FEMALE 3/4" CAP	1
4	X02.217.029	TUBO Ø8x13 L=290	HOSE Ø8x13 L=290	1
5	X02.217.033	TUBO Ø8x13 L=330	HOSE Ø8x13 L=330	1
6	X02.217.038	TUBO Ø8x13 L=380	HOSE Ø8x13 L=380	1
7	X02.217.041	TUBO Ø8x13 L=410	HOSE Ø8x13 L=410	1
8	X20.014.000DX	MANO A 4 USCITE CON TUBETTI	FOUR OUTLETS	1
9	X20.697.000	FERMA DIFFUSORI	NOZZLE STOP	4
10	XD0.06.5588G	DADO M6 6S PG 5588 ZINC.	M6 6S BIG LEAD NUT 5588	2
11	XFC.012,5.014	FASCETTA COBRA SL030705	KOBRA CLAMP SL030705	4
12	XFC.013,5.015	FASCETTA COBRA SL030710	KOBRA CLAMP SL030710	4
13	XRP.006.000	RONDELLA PIANA D.6 6592 ZINC.	6mm D. FLAT WASHER	4
14	XTE.006.020T	VITE TE M6X20 5739 ZINC.	BOLT TE M6X20 5739	2

X20.014.000DX

N°	Doc. Number	Titolo	Title	Q.tà
1	X20.016.01C	RACCORDO ATTACCO RAPIDO PORTA TUBETTO	PIPE WITH OLIVE	4

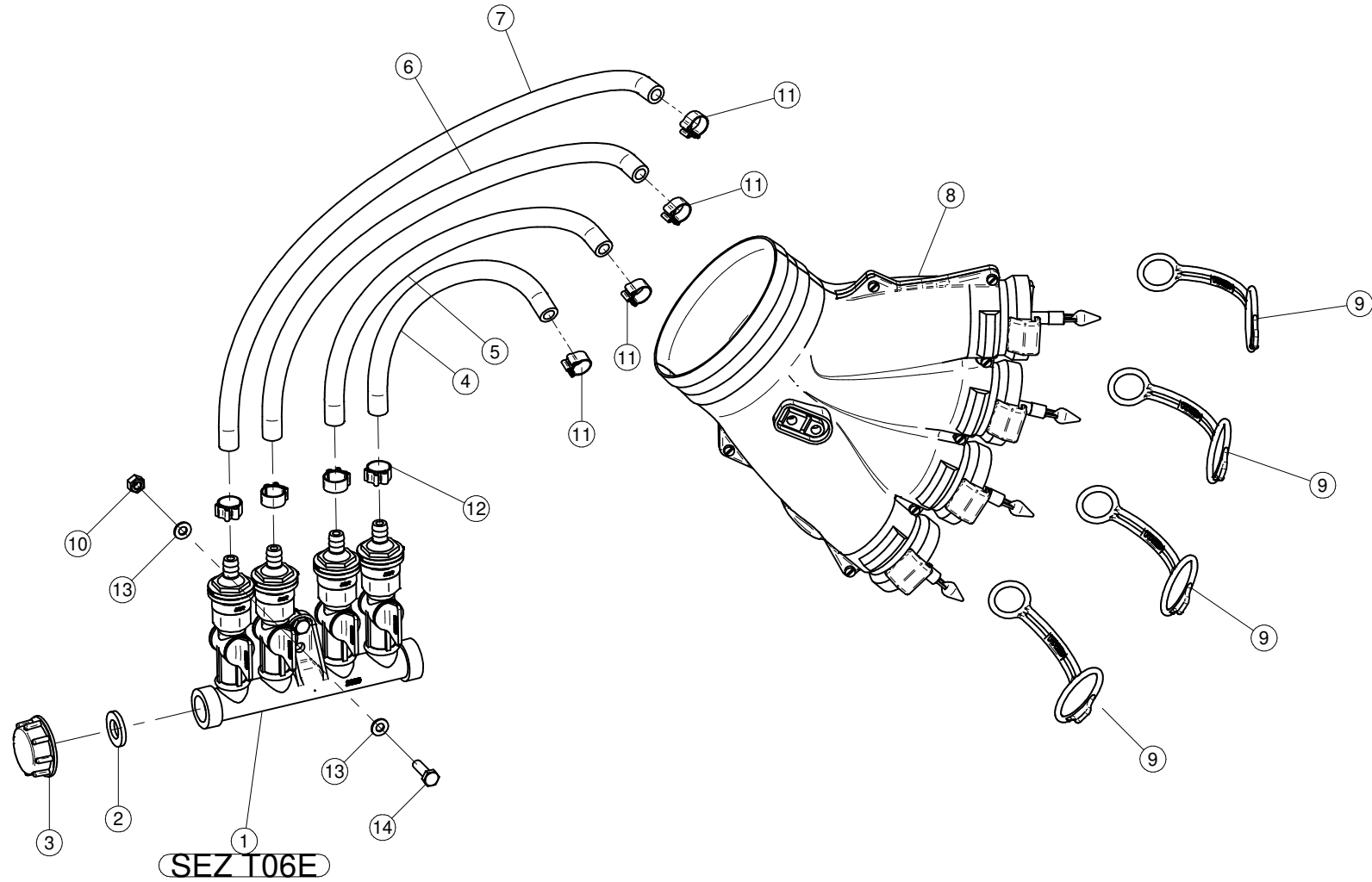

N°	Doc. Number	Titolo	Title	Q.tà
1	X02.008.304C	DISTRIBUTORE LIQUIDI A 4 RUBINETTI CON ANTIGOCCIA	FOUR TAPS LIQUID DISTRIBUTOR WITH ANTI-DRIP DEVICE	1
2	X02.030.010	GUARNIZIONE IN GOMMA D.24X13X3	GASKET D.24X13X3	1
3	X02.182.000	TAPPO 3/4" F.	FEMALE 3/4" CAP	1
4	X02.217.026	TUBO Ø8x13 L=260	HOSE Ø8x13 L=260	1
5	X02.217.034	TUBO Ø8x13 L=340	HOSE Ø8x13 L=340	1
6	X02.217.041	TUBO Ø8x13 L=410	HOSE Ø8x13 L=410	1
7	X02.217.046	TUBO Ø8x13 L=460	HOSE Ø8x13 L=460	1
8	X20.014.000SX	MANO A 4 USCITE CON TUBETTI	FOUR OUTLETS	1
9	X20.697.000	FERMA DIFFUSORI	NOZZLE STOP	4
10	XD0.06.5588G	DADO M6 6S PG 5588 ZINC.	M6 6S BIG LEAD NUT 5588	2
11	XFC.012,5.014	FASCETTA COBRA SL030705	KOBRA CLAMP SL030705	4
12	XFC.013,5.015	FASCETTA COBRA SL030710	KOBRA CLAMP SL030710	4
13	XRP.006.000	RONDELLA PIANA D.6 6592 ZINC.	6mm D. FLAT WASHER	4
14	XTE.006.020T	VITE TE M6X20 5739 ZINC.	BOLT TE M6X20 5739	2

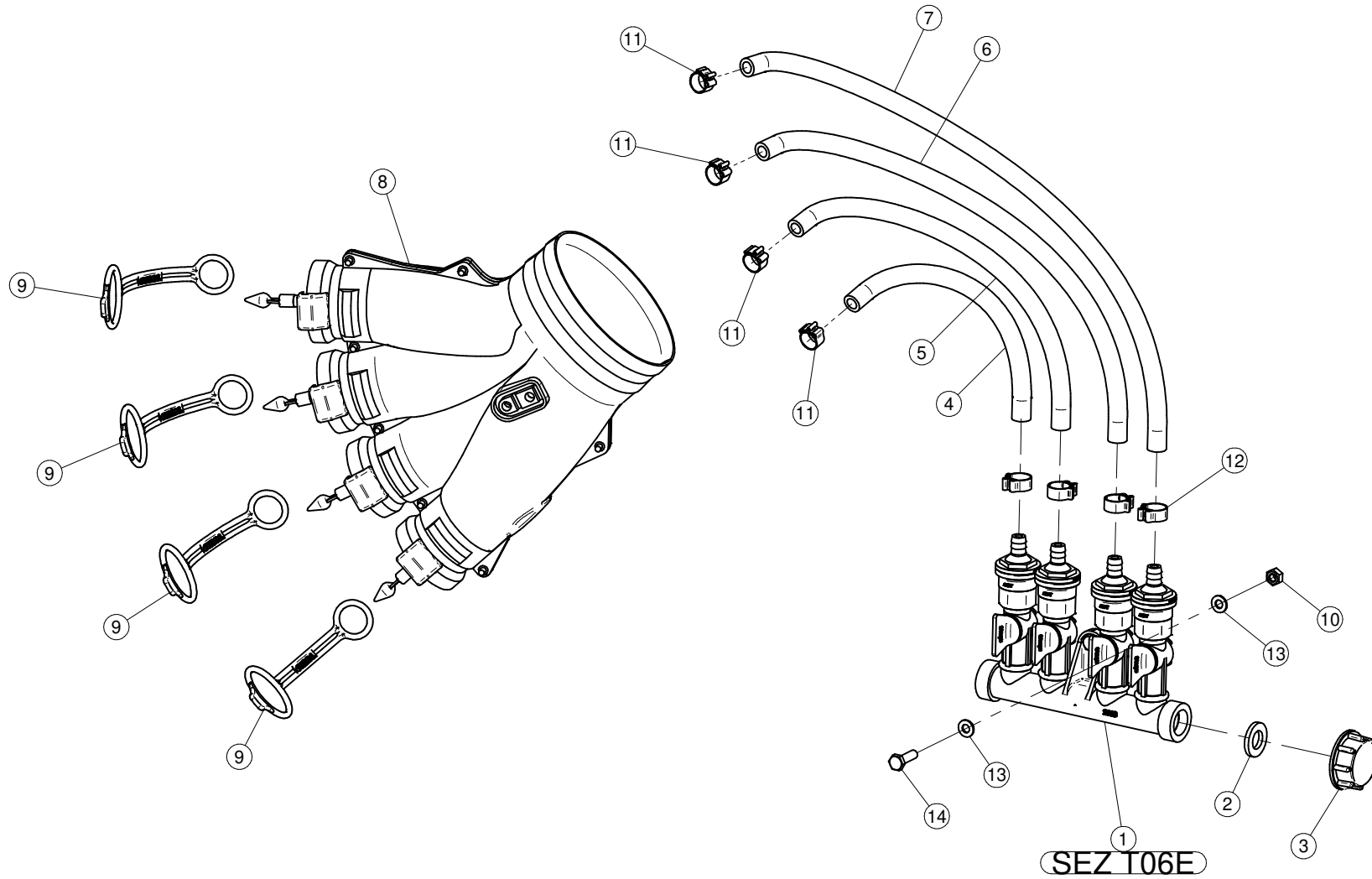

N°	Doc. Number	Titolo	Title	Q.tà
1	X02.008.304C	DISTRIBUTORE LIQUIDI A 4 RUBINETTI CON ANTIGOCCIA	FOUR TAPS LIQUID DISTRIBUTOR WITH ANTI-DRIP DEVICE	1
2	X02.030.010	GUARNIZIONE IN GOMMA D.24X13X3	GASKET D.24X13X3	1
3	X02.182.000	TAPPO 3/4" F.	FEMALE 3/4" CAP	1
4	X02.217.026	TUBO Ø8x13 L=260	HOSE Ø8x13 L=260	1
5	X02.217.034	TUBO Ø8x13 L=340	HOSE Ø8x13 L=340	1
6	X02.217.041	TUBO Ø8x13 L=410	HOSE Ø8x13 L=410	1
7	X02.217.046	TUBO Ø8x13 L=460	HOSE Ø8x13 L=460	1
8	X20.014.000DX	MANO A 4 USCITE CON TUBETTI	FOUR OUTLETS	1
9	X20.697.000	FERMA DIFFUSORI	NOZZLE STOP	4
10	XD0.06.5588G	DADO M6 6S PG 5588 ZINC.	M6 6S BIG LEAD NUT 5588	2
11	XFC.012,5.014	FASCETTA COBRA SL030705	KOBRA CLAMP SL030705	4
12	XFC.013,5.015	FASCETTA COBRA SL030710	KOBRA CLAMP SL030710	4
13	XRP.006.000	RONDELLA PIANA D.6 6592 ZINC.	6mm D. FLAT WASHER	4
14	XTE.006.020T	VITE TE M6X20 5739 ZINC.	BOLT TE M6X20 5739	2

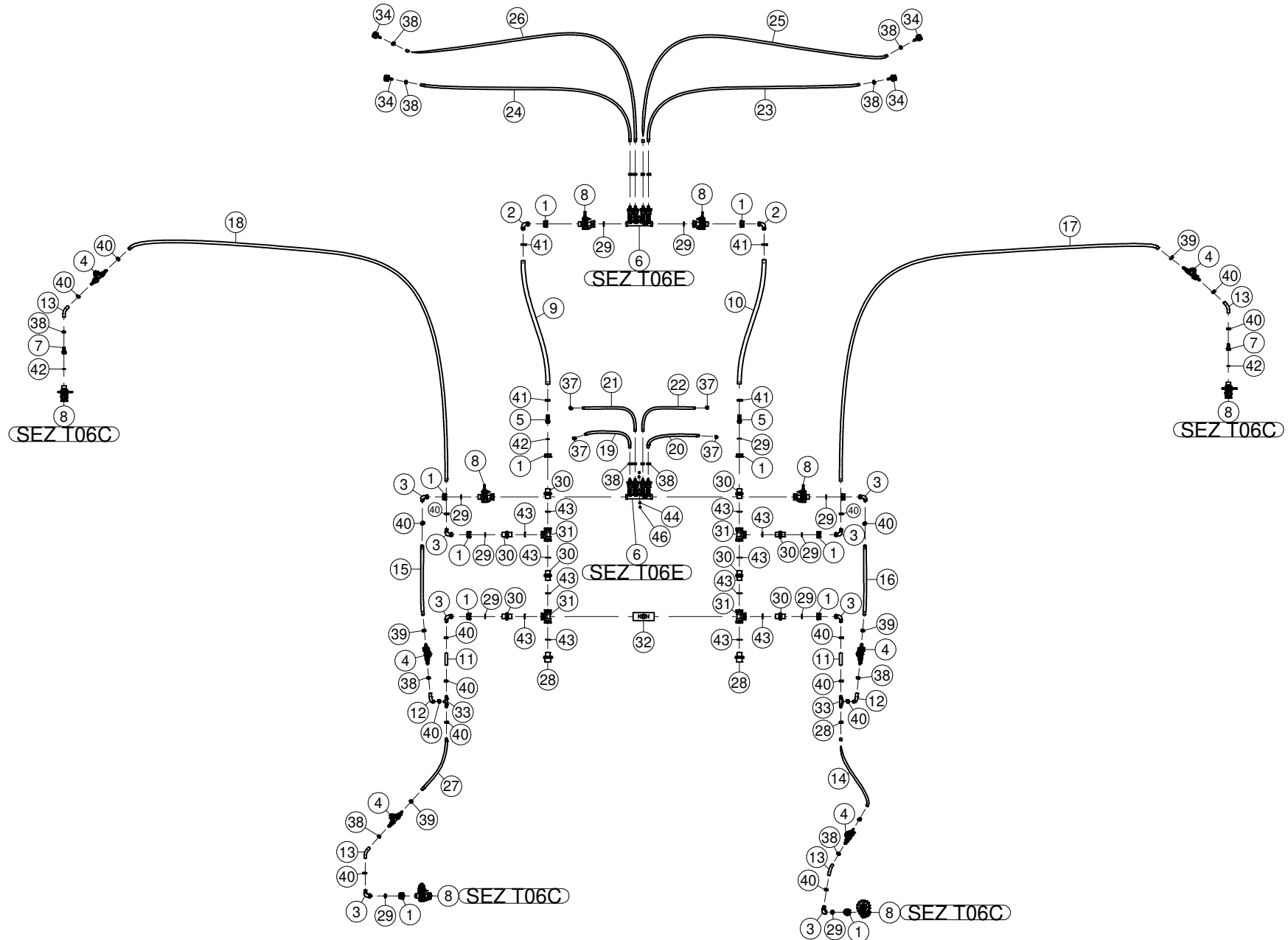

N°	Doc. Number	Titolo	Title	Q.tà
1	X00.055.045	GIRELLO 3/4" GAS ALTO	3/4" GAS FLY NUT	12
2	X00.055.046	RACCORDO CURVO P.G. Ø16	CURVED UNION WITH R.H. Ø16	2
3	X00.055.046R	RACCORDO CURVO P.G. Ø 14	CURVED UNION WITH R.H. D.14	8
4	X00.226.05C	GETTO ANTIGOCCIA DIRITTO COMPLETO (0,3 bar)	COMPLETE ANTIDROP (0,3 bar)	6
5	X02.002.000	RACCORDO DIRITTO 3/4" P.G.16	STRAIGHT UNION 3/4" R.H.16	2
6	X02.008.404C	DISTRIBUTORE LIQUIDI A 4 RUBINETTI	4 TAPS LIQUID MANIFOLD	2
7	X02.122.000	RACCORDO A P.G. Ø 13	Ø 13 UNION	2
8	X02.150.000	REGOLATORE A DISCO ROTANTE COMPLETO	ROTATION DISK REGULATION	8
9	X02.211.100	TUBO Ø16x23 L=1000	HOSE Ø16x23 L=1000	1
10	X02.211.100	TUBO Ø 16 X 23 L=1000	HOSE Ø 16 X 23 L=1000	1
11	X02.213.007	TUBO Ø10x16 L=70	HOSE Ø10x16 L=70	2
12	X02.213.007	TUBO Ø10x16 L=70	HOSE Ø10x16 L=70	2
13	X02.213.007	TUBO Ø10x16 L=70	HOSE Ø10x16 L=70	4
14	X02.213.025	TUBO Ø 10 X 16 L=250	HOSE Ø 10 X 16 L=250	1
15	X02.213.040	TUBO Ø10x16 L=400	HOSE Ø10x16 L=400	1
16	X02.213.040	TUBO Ø10x16 L=400	HOSE Ø10x16 L=400	1
17	X02.213.300	TUBO Ø10x16 L=3000	HOSE Ø10x16 L=3000	1
18	X02.213.300	TUBO Ø10x16 L=3000	HOSE Ø10x16 L=3000	1
19	X02.217.047	TUBO Ø8x13 L=470	HOSE Ø8x13 L=470	1
20	X02.217.047	TUBO Ø8x13 L=470	HOSE Ø8x13 L=470	1
21	X02.217.054	TUBO Ø8x13 L=540	HOSE Ø8x13 L=540	1
22	X02.217.054	TUBO Ø8x13 L=540	HOSE Ø8x13 L=540	1
23	X02.217.200	TUBO Ø8x13 L=2000	HOSE Ø8x13 L=2000	1
24	X02.217.200	TUBO Ø8x13 L=2000	HOSE Ø8x13 L=2000	1
25	X02.217.220	TUBO Ø8x13 L=2200	HOSE Ø8x13 L=2200	1
26	X02.217.220	TUBO Ø8x13 L=2200	HOSE Ø8x13 L=2200	1
27	X02.231.025	TUBO Ø 10 X 16 L=250	HOSE Ø 10 X 16 L=250	1
28	X02.293.000	RIDUZIONE 1" M - 3/4" M	1" M - 3/4" M REDUCER NIPPLE	2
29	X02.349.000	GUARNIZIONE PIANA D.17X23X3	17X23X3 FLAT GASKET (G4000B)	12
30	X02.380.000	NIPPLO 3/4"	NIPPLE 3/4"	8
31	X02.396.000	RACCORDO A T 3/4" - 3/4" - 3/4" F.	UNION 3/4" - 3/4" - 3/4" F.	4
32	X02.999.000	STAFFA FISSAGGIO RACCORDO A T	T UNION FIXING BRACKET	1
33	X20.885.000	RACCORDO A T Ø13-13-13	T UNION Ø 13-13-13	2
34	X21.010.000	RACCORDO P.G. DIRITTO Ø 10 COMPLETO	COMPLETE R.H. Ø 10 UNION	4
35*	XD0.06.5588G	DADO M6 6S PG 5588	M6 6S BIG LEAD NUT 5588	4
36*	XDA.010.0BG	DADO AUTOBLOCCANTE M10	SELF LOCKING NUT M10	1
37	XFC.012,5.014	FASCETTA COBRA SL030705	KOBRA CLAMP SL030705	4
38	XFC.013,5.015	FASCETTA COBRA SL030710	KOBRA CLAMP SL030710	17
39	XFC.015,5.017	FASCETTA COBRA SLO30720	KOBRA CLAMP	5
40	XFC.016,5.018	FASCETTA COBRA 16,5 - 18	KOBRA CLAMP 16,5 - 18	18
41	XFC.022,5.024	FASCETTA COBRA SLO30756	KOBRA CLAMP SLO30756	4
42	XOR.000.117	OR D.13,1X2,62	13.1X2.62 O-RING GASKET	4
43	XOR.004.081	OR Ø 20,22 x 3,53	20,22 x 3,53 O-RING GASKET	12
44	XRP.006.000	RONDELLA PIANA D.6 6592 ZINC.	6mm D. FLAT WASHER	8
45*	XRP.010.000	RONDELLA PIANA D.10 6592 ZINC.	WASHER Ø 10	2
46	XTE.006.020T	VITE TE M6X20 5739 ZINC.	BOLT TE M6X20 5739	4
47*	XTE.010.035T	VITE TE UNI 5739-65 M10x35-8.8	SCREW TE UNI 5739-65 M10x35-8.8	1

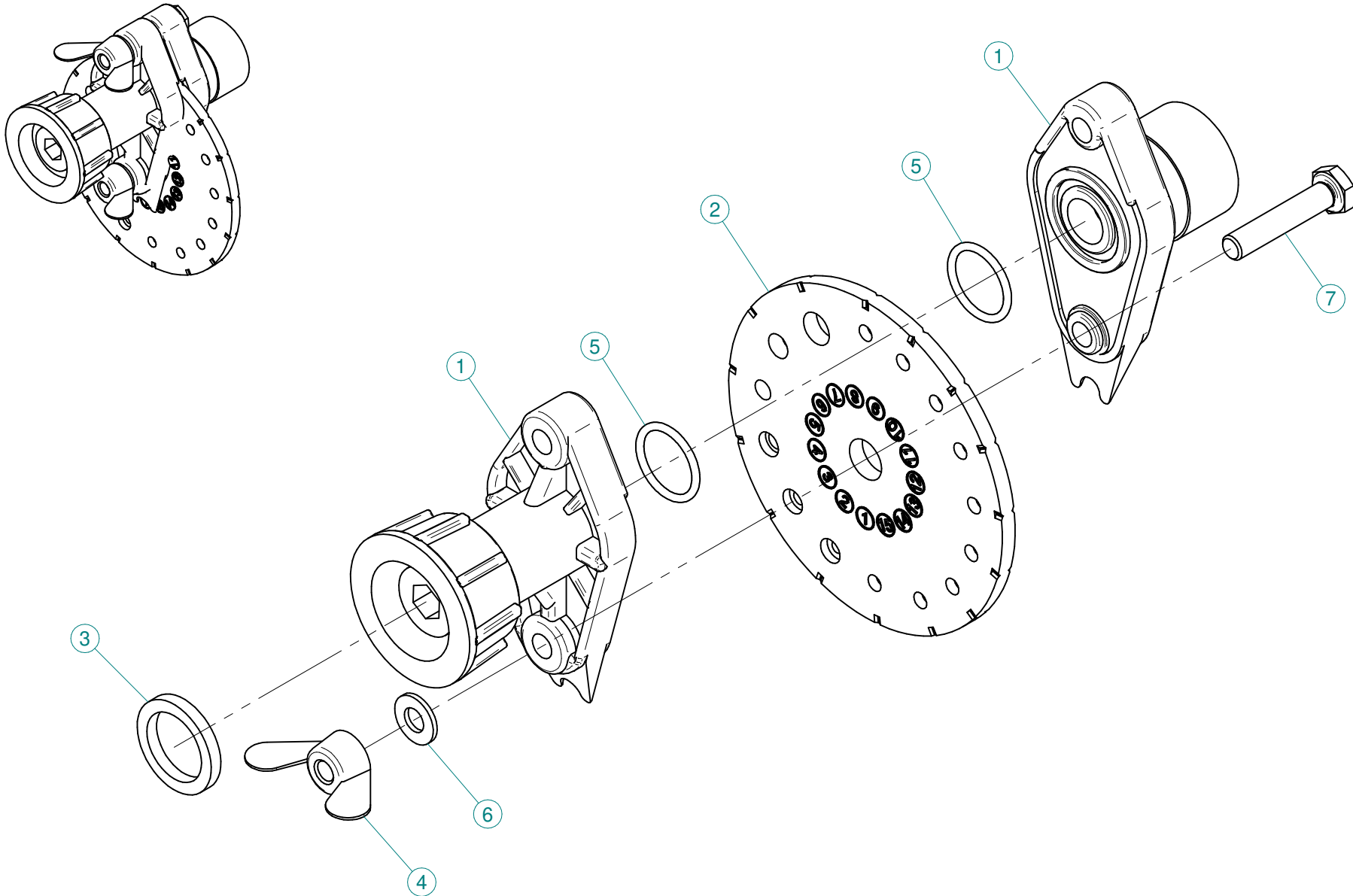

N°	Doc. Number	Titolo	Title	Q.tà
1	X02.147.500	COPPIA DI SEMICORPO REGOLATORE	REGULATOR HALF-BODY	1
2	X02.148.000	DISCO ROTANTE PER REGOLATORE	REGULATOR DISK	1
3	X02.349.000	GUARNIZIONE PIANA D.17X23X3	17X23X3 FLAT GASKET (G4000B)	1
4	XDF.OTT.006	DADO AD ALETTE IN OTTONE M6	BRASS M6 WING NUT	2
5	XOR.002.062	OR D.15,6X1,78	15.6X1.78 O-RING GASKET	2
6	XRP.006.001	RONDELLA PIANA D.6 INOX	WASHER D.6	2
7	XTE.006.030I	VITE TE M6X30 INOX 5739	BOLT TE M6X30 STAINLESS STEEL 5739	2

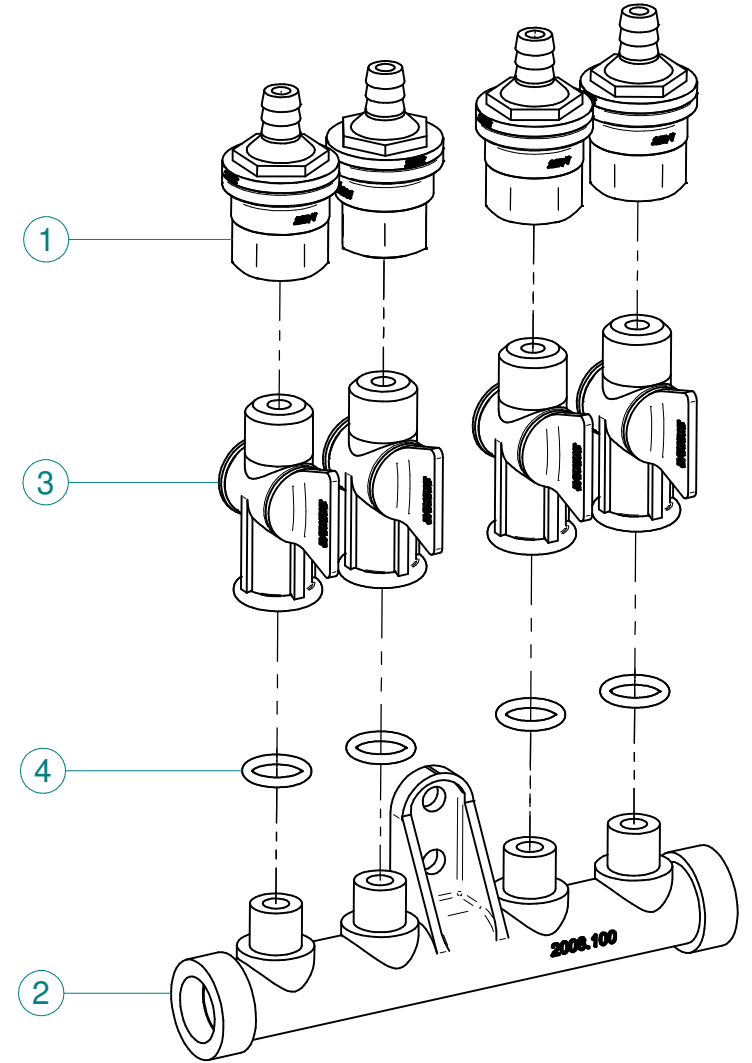
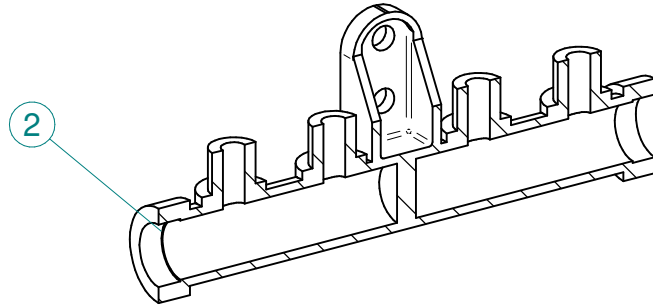

N°	Doc. Number	Titolo	Title	Q.tà
1	X00.227.01C	DISPOSITIVO ANTIGOCCIA	ANTI DRIP DEVICE	4
2	X02.008.100	DISTRIBUTORE LIQUIDO TESTATE DIVISO	SPRAYHEAD LIQUID DISTRIBUTOR	1
3	X20.202.100	RUBINETTO F.1/4" M.18X1,5	TAP ASSEMBLY	4
4	XOR.000.117	OR D.13,1X2,62	13.1X2.62 O-RING GASKET	4