

Sez. T06
Circuito idraulico
Plumbing of liquids

Sez. T03
Condotto dell'aria
Air duct

Sez. T01
Telaio
Metallic frame

Sez. T25 (⌘)
Movimentazione Elettrica
Electrical Movement

Sez. T28 (⌘)
Prolunghe
Extension

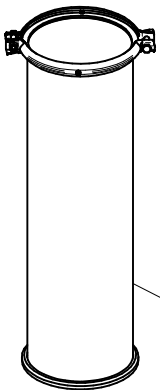
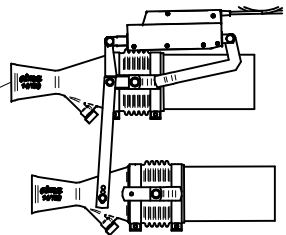

(⌘) A richiesta / Optional Devices

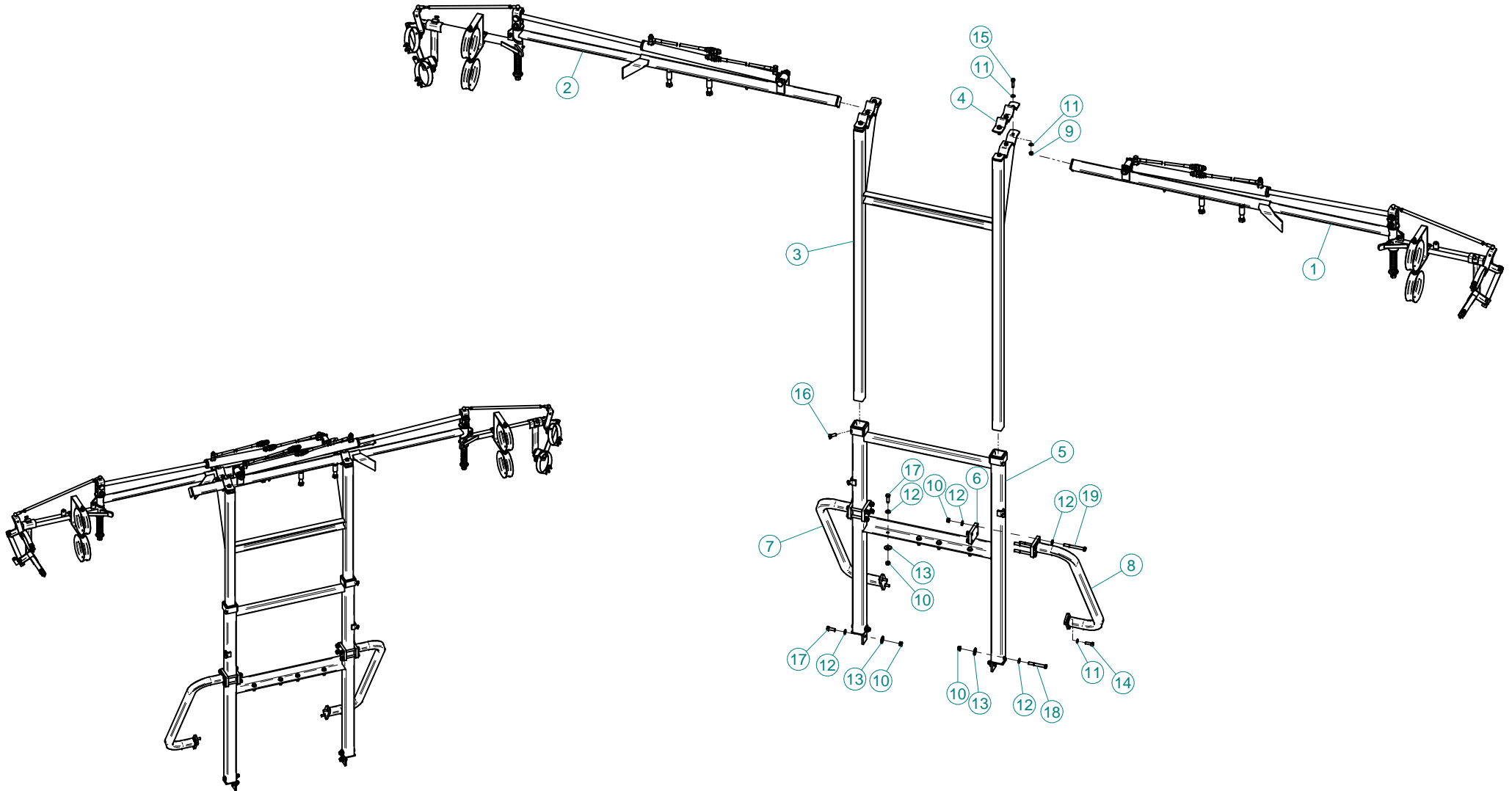

N°	Doc. Number	Titolo	Title	Q.tà
1	X20.742.000X	BRACCIO LATERALE SINISTRO	LEFT ARM	1
2	X20.742.000Y	BRACCIO LATERALE DESTRO	RIGHT ARM	1
3	X20.742.002	TELAIO CENTRALE SCORREVOLE	SLIDING FRAME	1
4	X20.742.015	GUIDA BRACCI SCORREVOLE	SLIDING ARMS GUIDE	2
5	X20.742.017	TELAIO CENTRALE T.C.I.	MAIN FRAME	1
6	X20.937.000	PIASTRA FISSAGGIO TELAIETTO SOSTEGNO BRACCI	BRACKET	2
7	X50.232.000	TIRANTE DI SOSTEGNO SINISTRO	LEFT TIE-ROD	1
8	X50.232.100	TIRANTE DI SOSTEGNO DESTRO	RIGHT TIE-ROD	1
9	XD0.10.5587G	DADO M10 6S PG 5587 ZINC.	M10 6S BIG LEAD NUT 5587	4
10	XD0.12.5587G	DADO M12 6S PG 5587 ZINC.	M12 6S BIG LEAD NUT 5587	16
11	XRP.010.000	RONDELLA PIANA D.10 6592 ZINC.	WASHER Ø 10	14
12	XRP.012.000	RONDELLA PIANA Ø12	WASHER Ø12	24
13	XRP.012.036	RONDELLA PIANA D12 X 36	WASHER D12 X 36	8
14	XTE.010.035T	VITE TE UNI 5739-65 M10x35-8.8	SCREW TE UNI 5739-65 M10x35-8.8	4
15	XTE.010.040T	VITE TE UNI 5739-65 M10x40-8.8	SCREW TE UNI 5739-65 M10x40-8.8	6
16	XTE.012.030T	VITE TE UNI 5739-65 M12x30-8.8	SCREW TE UNI 5739-65 M12x30-8.8	4
17	XTE.012.035T	VITE TE UNI 5739-65 M12x35-8.8	SCREW TE UNI 5739-65 M12x35-8.8	6
18	XTE.012.090	VITE TE UNI 5737-65 M12x90-8.8	SCREW TE UNI 5737-65 M12x90-8.8	2
19	XTE.012.110	VITE TE UNI 5737-65 M12x110-8.8	SCREW TE UNI 5737-65 M12x110-8.8	8

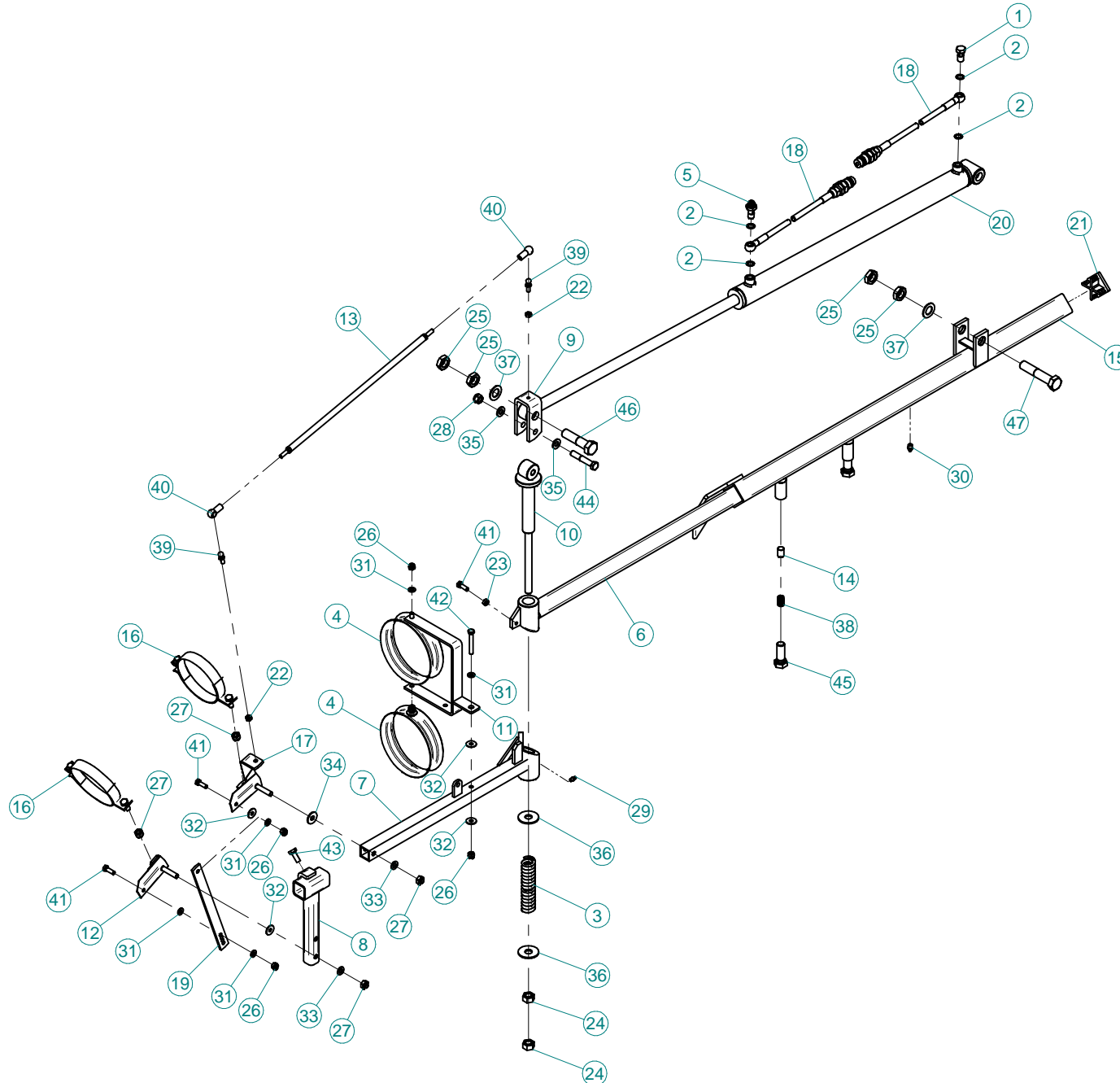

N°	Doc. Number	Titolo	Title	Q.tà	N°	Doc. Number	Titolo	Title	Q.tà
1	X02.408.000	RACCORDO DRITTO PER OCCHIO 1/4"	JACK EYE RIGHT UNION 1/4"	1	43	XTE.010.025	VITE TE UNI 5737-65 M10x25-8.8	SCREW TE UNI 5737-65 M10x25-8.8	1
2	X02.472.000	RONDELLA DI RAME Ø 19x13,5x1,5	COPPER WASHER Ø 19x13,5x1,5	4	44	XTE.012.070	VITE TE UNI 5737-65 M12x70-8.8	SCREW TE UNI 5737-65 M12x70-8.8	1
3	X07.528.000	MOLLA A COMPRESSIONE INT.D.20XF.D.6XL=140	SPRING INT.D.20XF.D.6XL=140	1	45	XTE.018.050T	VITE TE UNI 5737-65 M18x50-8.8	SCREW TE UNI 5737-65 M18x50-8.8	2
4	X20.227.000	ANELLO GUIDA TUBI PICCOLO	SMALL PIPE GUIDE RING	2	46	XTE.020.080	VITE TE UNI 5737-65 M20x80-8.8	SCREW TE UNI 5737-65 M20x80-8.8	1
5	X20.718.000	REGOLATORE PORTATA IDRAULICA 1/4"	FLOW REGULATOR 1/4"	1	47	XTE.020.100	VITE TE UNI 5737-65 M20x100-8.8	SCREW TE UNI 5737-65 M20x100-8.8	1
6	X20.742.003DX	BRACCIO LATERALE DESTRO SCORREVOLE	SLIDING RIGHT SIDE ARM	1					
7	X20.742.004DX	BRACCIO LATERALE DESTRO RIPIEGABILE	TURNING RIGHT SIDE ARM	1					
8	X20.742.005	ATTACCO ANELLO PICCOLO	SMALL RING ATTACH	1					
9	X20.742.006Z	CAVALLOTTO DI TRASCINAMENTO	U BOLT	1					
10	X20.742.007Z	PERNO D.28 COMPLETO	PIN	1					
11	X20.742.008	ATTACCO ANELLO GROSSO	LARGE RING ATTACH	1					
12	X20.742.010DX	ATTACCO ANELLO PICCOLO	SMALL RING ATTACH	1					
13	X20.742.012	ASTA DI COLLEGAMENTO	UNION ROD	1					
14	X20.742.014	TONDINO D.15 L=20	PIN D.15 L=20	2					
15	X20.742.016DX	BRACCIO LATERALE DESTRO FISSO	FIXING RIGHT SIDE ARM	1					
16	X20.742.018	ATTACCO ANELLO PICCOLO	SMALL RING ATTACH	2					
17	X20.742.024DX	ATTACCO ANELLO PICCOLO	SMALL RING ATTACH	1					
18	X20.900.680	TUBO OLIO PER MARTINETTO L=6800	OIL PIPE FOR JACK L=6800	2					
19	X20.922.000	STAFFA COLLEGAMENTO PER DIFF.MOVIM. IDRAULICA	UNION BRACKET	1					
20	X21.115.000	MARTINETTO COMPLETO D.50 CORSA 640 mm.	JACK SHAFT D.50 STROKE 640 mm.	1					
21	X21.314.000	TAPPO IN PLASTICA 50x50	TAPPO IN PLASTICA 50x50	1					
22	XD0.08.5588G	DADO M8 6S PG	M8 6S BIG LEAD NUT 5588	2					
23	XD0.08.5588G	DADO M8 6S PG 5588 ZINC.	M8 6S BIG LEAD NUT 5588	1					
24	XD0.16.5587G	DADO M16	NUT M16	2					
25	XD0.20.5589G	DADO BASSO M20	LOWER NUT M20	4					
26	XDA.008.0AG	DADO AUTOBLOCCANTE M8 ALTO PG ZINC.	HIGH BIG LEAD M8 SELFLOCKING	5					
27	XDA.010.0AG	DADO AUTOBLOCCANTE M10	SELF LOCKING NUT M10	4					
28	XDA.012.0AG	DADO AUTOBLOCCANTE M12	SELF LOCKING NUT M12	1					
29	XID.006.001	INGRASSATORE DIRITTO M6	GREASER	1					
30	XID.010.001	INGRASSATORE DIRITTO M 10X1 ZINC.	STRAIGHT GREASE NIPPLE	1					
31	XRP.008.000	RONDELLA PIANA D.8 6592 ZINC.	8 D. FLAT WASHER	6					
32	XRP.008.024	RONDELLA PIANA F.LARGA D.8X24 ZINC.	WASHER D.8X24	4					
33	XRP.010.000	RONDELLA PIANA D.10 6592 ZINC.	WASHER Ø 10	2					
34	XRP.010.030	RONDELLA PIANA F.LARGA D.10X30 ZINC.	10X30mm D. LARGE THREAD FLAT	1					
35	XRP.012.000	RONDELLA PIANA Ø12	WASHER Ø12	2					
36	XRP.016.048	RONDELLA PIANA D.16 x 48	WASHER	2					
37	XRP.020.000	RONDELLA PIANA D.20	WASHER D.20	2					
38	XS0.211.000	MOLLA D.INT. 9 x F.D.2,3 x L=22	SPRING	2					
39	XS0.212.000A	SPINA ATTACCO SNODO	JOINT PIN	2					
40	XS0.212.000B	SNODO	JOINT	2					
41	XTE.008.025T	VITE TE M8X25	BOLT TE M8X25	3					
42	XTE.008.060T	VITE TE UNI 5739-65 M8x60-8.8	SCREW TE UNI 5739-65 M8x60-8.8	1					

N°	Doc. Number	Titolo	Title	Q.tà	N°	Doc. Number	Titolo	Title	Q.tà
1	X02.408.000	RACCORDO DRITTO PER OCCHIO 1/4"	JACK EYE RIGHT UNION 1/4"	1	43	XTE.008.060T	VITE TE UNI 5739-65 M8x60-8.8	SCREW TE UNI 5739-65 M8x60-8.8	1
2	X02.472.000	RONDELLA DI RAME Ø 19x13,5x1,5	COPPER WASHER Ø 19x13,5x1,5	4	44	XTE.010.025	VITE TE UNI 5737-65 M10x25-8.8	SCREW TE UNI 5737-65 M10x25-8.8	1
3	X07.528.000	MOLLA A COMPRESSIONE INT.D.20XF.D.6XL=140	SPRING INT.D.20XF.D.6XL=140	1	45	XTE.012.070	VITE TE UNI 5737-65 M12x70-8.8	SCREW TE UNI 5737-65 M12x70-8.8	1
4	X20.227.000	ANELLO GUIDA TUBI PICCOLO	SMALL PIPE GUIDE RING	2	46	XTE.018.050T	VITE TE UNI 5737-65 M18x50-8.8	SCREW TE UNI 5737-65 M18x50-8.8	2
5	X20.718.000	REGOLATORE PORTATA IDRAULICA 1/4"	FLOW REGULATOR 1/4"	1	47	XTE.020.080	VITE TE UNI 5737-65 M20x80-8.8	SCREW TE UNI 5737-65 M20x80-8.8	1
6	X20.742.003SX	BRACCIO LATERALE SINISTRO SCORREVOLE	SLIDING LEFT SIDE ARM	1	48	XTE.020.100	VITE TE UNI 5737-65 M20x100-8.8	SCREW TE UNI 5737-65 M20x100-8.8	1
7	X20.742.004SX	BRACCIO LATERALE SINISTRO RIPIEGABILE	TURNING LEFT SIDE ARM	1					
8	X20.742.005	ATTACCO ANELLO PICCOLO	SMALL RING ATTACH	1					
9	X20.742.006Z	CAVALLOTTO DI TRASCINAMENTO	U BOLT	1					
10	X20.742.007Z	PERNO D.28 COMPLETO	PIN	1					
11	X20.742.008	ATTACCO ANELLO GROSSO	LARGE RING ATTACH	1					
12	X20.742.010SX	ATTACCO ANELLO PICCOLO	SMALL RING ATTACH	1					
13	X20.742.012	ASTA DI COLLEGAMENTO	UNION ROD	1					
14	X20.742.014	TONDINO D.15 L=20	PIN D.15 L=20	2					
15	X20.742.016SX	BRACCIO LATERALE SINISTRO FISSO	FIXING LEFT SIDE ARM	1					
16	X20.742.018	ATTACCO ANELLO PICCOLO	SMALL RING ATTACH	2					
17	X20.742.024SX	ATTACCO ANELLO PICCOLO	SMALL RING ATTACH	1					
18	X20.900.680	TUBO OLIO PER MARTINETTO L=6800	OIL PIPE FOR JACK L=6800	2					
19	X20.922.000	STAFFA COLLEGAMENTO PER DIFF.MOVIM. IDRAULICA	UNION BRACKET	1					
20	X21.115.000	MARTINETTO COMPLETO D.50 CORSA 640 mm.	JACK SHAFT D.50 STROKE 640 mm.	1					
21	X21.115.000	MARTINETTO COMPLETO D.50 CORSA 640 mm.	JACK SHAFT D.50 STROKE 640 mm.	1					
22	X21.314.000	TAPPO IN PLASTICA 50x50	TAPPO IN PLASTICA 50x50	1					
23	XD0.08.5588G	DADO M8 6S PG	M8 6S BIG LEAD NUT 5588	2					
24	XD0.08.5588G	DADO M8 6S PG 5588 ZINC.	M8 6S BIG LEAD NUT 5588	1					
25	XD0.16.5587G	DADO M16	NUT M16	2					
26	XD0.20.5589G	DADO BASSO M20	LOWER NUT M20	4					
27	XDA.008.0AG	DADO AUTOBLOCCANTE M8 ALTO PG ZINC.	HIGH BIG LEAD M8 SELFLOCKING	5					
28	XDA.010.0AG	DADO AUTOBLOCCANTE M10	SELF LOCKING NUT M10	4					
29	XDA.012.0AG	DADO AUTOBLOCCANTE M12	SELF LOCKING NUT M12	1					
30	XID.006.001	INGRASSATORE DIRITTO M6	GREASER	1					
31	XID.010.001	INGRASSATORE DIRITTO M 10X1 ZINC.	STRAIGHT GREASE NIPPLE	1					
32	XRP.008.000	RONDELLA PIANA D.8 6592 ZINC.	8 D. FLAT WASHER	6					
33	XRP.008.024	RONDELLA PIANA F.LARGA D.8X24 ZINC.	WASHER D.8X24	4					
34	XRP.010.000	RONDELLA PIANA D.10 6592 ZINC.	WASHER Ø 10	2					
35	XRP.010.030	RONDELLA PIANA F.LARGA D.10X30 ZINC.	10X30mm D. LARGE THREAD FLAT	1					
36	XRP.012.000	RONDELLA PIANA Ø12	WASHER Ø12	2					
37	XRP.016.048	RONDELLA PIANA D.16 x 48	WASHER	2					
38	XRP.020.000	RONDELLA PIANA D.20	WASHER D.20	2					
39	XS0.211.000	MOLLA D.INT. 9 x F.D.2,3 x L=22	SPRING	2					
40	XS0.212.000A	SPINA ATTACCO SNODO	JOINT PIN	2					
41	XS0.212.000B	SNODO	JOINT	2					
42	XTE.008.025T	VITE TE M8X25	BOLT TE M8X25	3					

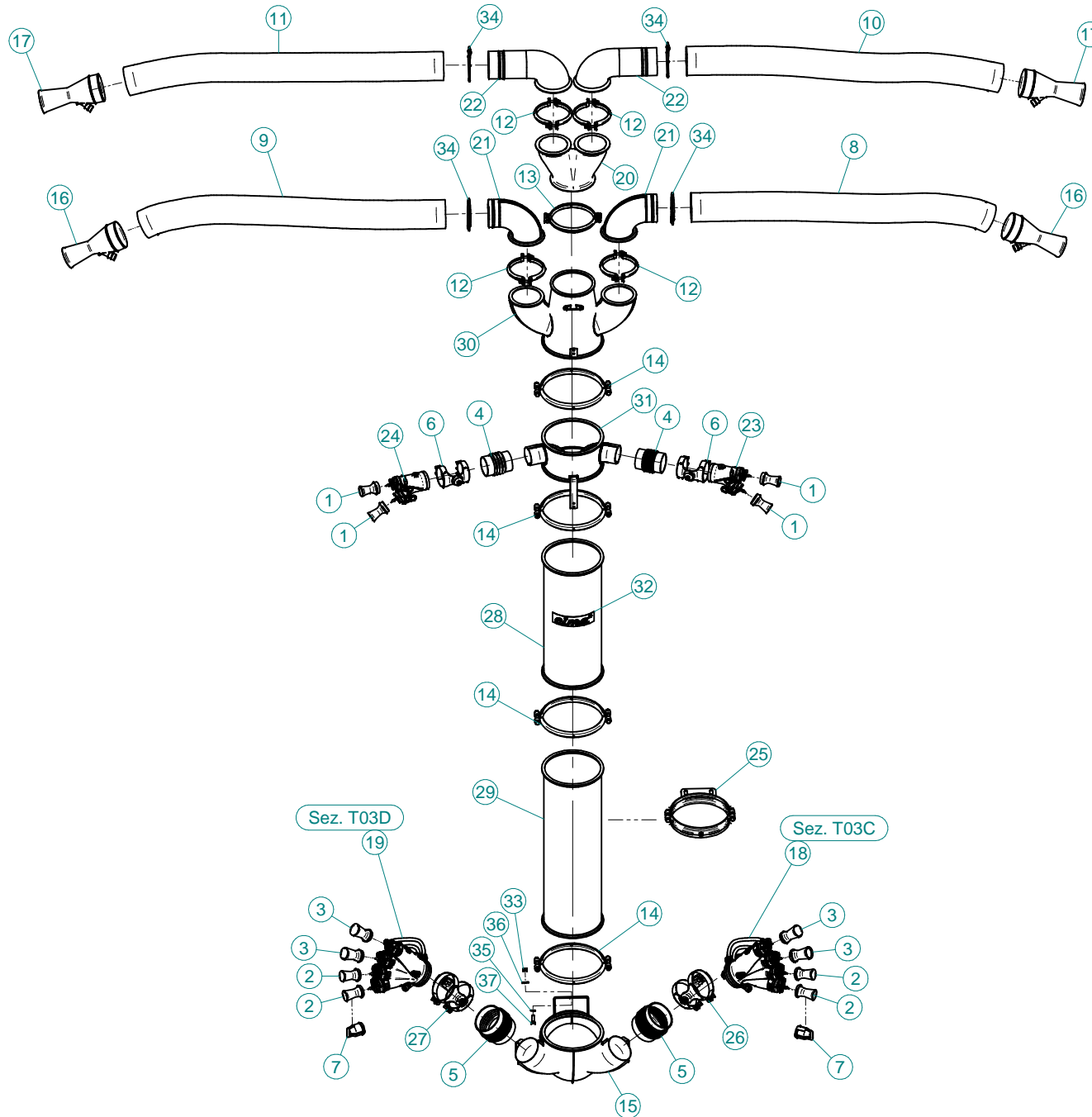

N°	Doc. Number	Titolo	Title	Q.tà
1	X00.004,5.50	DIFFUSORE 4,5/50	NOZZLE 4,5/50	4
2	X00.006.050	DIFFUSORE 6/50	NOZZLE 6/50	4
3	X00.008.050	DIFFUSORE 8/50	NOZZLE 8/50	4
4	X02.020.000	MANICOTTO FLESSIBILE Ø 80 x 115	FLEXIBLE SLEEVE Ø 80 x 115	2
5	X02.021.000	MANICOTTO FLESSIBILE D.120X120	120 D. FLEXIBLE SLEEVE	2
6	X02.046.000	COPPIA FASCETTE Ø 85	CLAMP Ø 85	2
7	X02.127.000	TAPPO DI ATTACCO RAPIDO	CAP NOZZLE PLUG	2
8	X02.239.140	TUBO SPIRALATO Ø120 L=1400	TANEGUM HOSE Ø120 L=1400	1
9	X02.239.140	TUBO SPIRALATO Ø120 L=1400	TANEGUM HOSE Ø120 L=1400	1
10	X02.239.153	TUBO SPIRALATO Ø120 L=1530	TANEGUM HOSE Ø120 L=1530	1
11	X02.239.153	TUBO SPIRALATO Ø120 L=1530	TANEGUM HOSE Ø120 L=1530	1
12	X04.027.000	COLLARE PER TUBI D. 150	PIPE CLAMP D. 150	4
13	X05.616.000	COLLARE PER TUBI Ø 175	PIPE CLAMP Ø 175	1
14	X05.813.000	COLLARE Ø275	CLAMP Ø275	4
15	X05.843.200	CORPO D.250 CON DUE USCITE D.120	BODY D.250 WITH 2 OUTLETS D.120	1
16	X10.022,5.120	DIFFUSORE 22,5/120 CON TUBETTO	NOZZLE 22,5/120	2
17	X10.027.120	DIFFUSORE 27/120 CON TUBETTO	NOZZLE 27/120	2
18	X20.014.404CDX	MANO A 4 USCITE COMPLETA DI DISTRIBUZIONE	FOUR NOZZLES DIFFUSER	1
19	X20.014.404CSX	MANO A 4 USCITE COMPLETA DI DISTRIBUZIONE	FOUR NOZZLES DIFFUSER	1
20	X20.204.003	CORPO A Y D.175 IN P.E.	Y BODY IN P.E.	1
21	X20.205.020	CURVA D.120 L=170 PER TC	ELBOW D.120 L=170 PER TC	2
22	X20.205.030	CURVA D.120 L=290 PER TC IN POLIETILENE	ELBOW D.120 L=290 FOR TC	2
23	X20.221.100DX	MANO Ø 80 A DUE USCITE	TWO OUTLETS BODY	1
24	X20.221.100SX	MANO Ø 80 A DUE USCITE	TWO OUTLETS BODY	1
25	X20.504.000	FASCETTA Ø250 FISSAGGIO TESTATE	Ø250 CLAMP HEADS FIXING	1
26	X21.080.000	COPPIA FASCETTE Ø 127 DESTRA	RIGHT CLAMP Ø 127	1
27	X21.081.000	COPPIA FASCETTE Ø 127 SINISTRA	LEFT CLAMP Ø 127	1
28	X21.100.060	PROLUNGA D.250 x 600	EXTENSION D.250 x 600	1
29	X21.100.080	PROLUNGA D.250 X 800 MM.	250mm INTERNAL D.800mm LENGTH	1
30	X50.078.000	CORPO D.250-175 CON DUE USCITE D.130	BODY D.250-175 WITH 2 OUTLETS D.130	1
31	X50.081.000	CORPO ø250 L=150 CON 2 USCITE ø80	BODY ø250 L=150 WITH 2 OUTLETS ø80	1
32	X96.118.000	ADESIVO - CIMA 100x200	DECALS - CIMA 100x200	1
33	XD0.10.5587G	DADO M10 6S PG 5587 ZINC.	M10 6S BIG LEAD NUT 5587	1
34	XF0.120.000	FASCETTA UNIFILO D.120	CLAMP D.120	4
35	XRP.010.000	RONDELLA PIANA D.10 6592 ZINC.	WASHER Ø 10	1
36	XRP.010.030	RONDELLA PIANA F.LARGA D.10X30 ZINC.	10X30mm D. LARGE THREAD FLAT	1
37	XTE.010.030T	VITE TE UNI 5739-65 M10x30-8.8	SCREW TE UNI 5739-65 M10x30-8.8	1

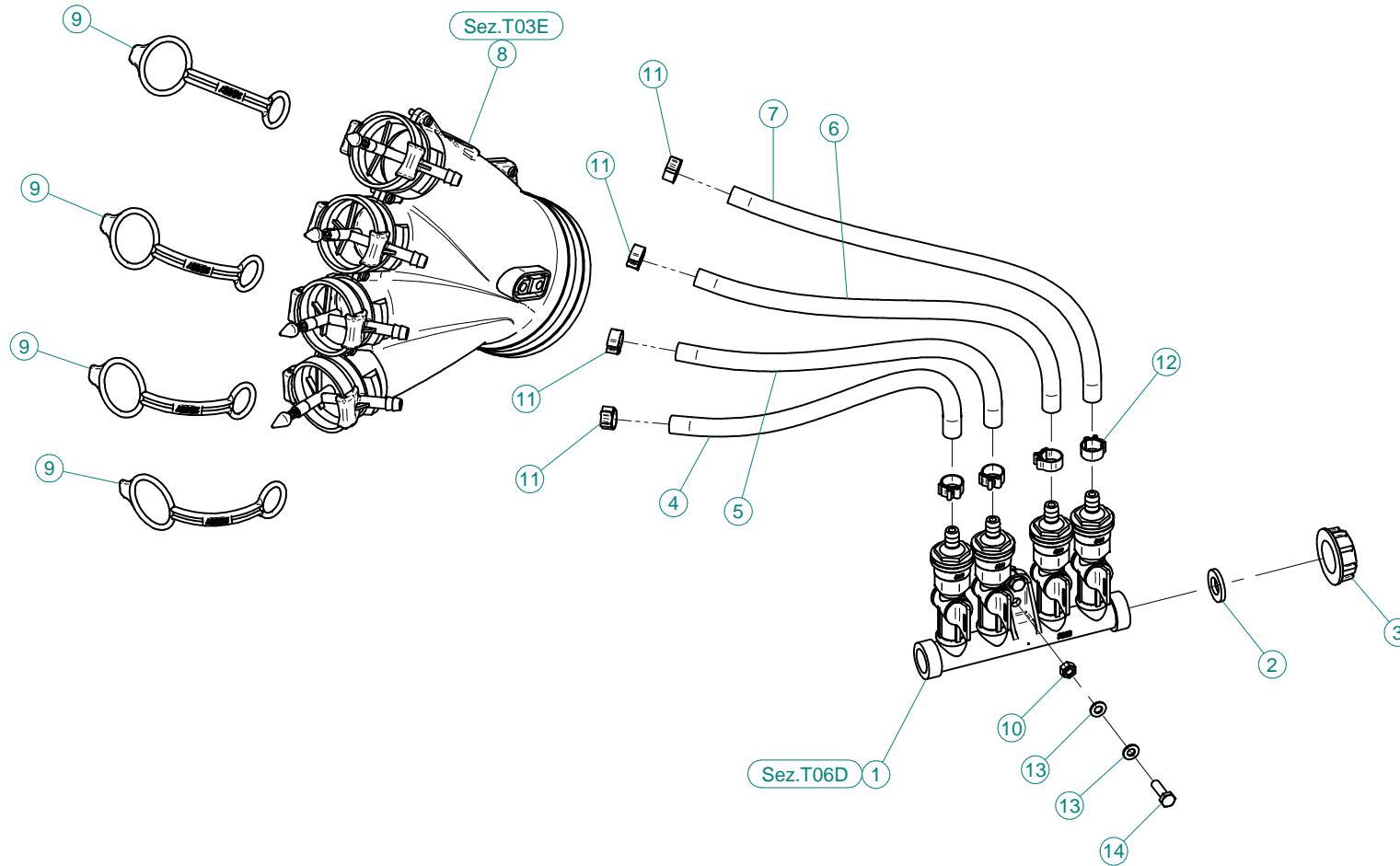

N°	Doc. Number	Titolo	Title	Q.tà
1	X02.008.304C	DISTRIBUTORE LIQUIDI A 4 RUBINETTI CON ANTIGOCCIA	FOUR TAPS LIQUID DISTRIBUTOR WITH ANTI-DRIP DEVICE	1
2	X02.030.010	GUARNIZIONE IN GOMMA D.24X13X3	GASKET D.24X13X3	1
3	X02.182.000	TAPPO 3/4" F.	FEMALE 3/4" CAP	1
4	X02.217.029	TUBO D.8x13 L=290	HOSE D.8x13 L=290	1
5	X02.217.033	TUBO D.8x13 L=330	HOSE D.8x13 L=330	1
6	X02.217.038	TUBO D.8x13 L=380	HOSE D.8x13 L=380	1
7	X02.217.041	TUBO D.8x13 L=410	HOSE D.8x13 L=410	1
8	X20.014.000DX	MANO A 4 USCITE CON TUBETTI	FOUR OUTLETS	1
9	X20.697.000	FERMA DIFFUSORI	NOZZLE STOP	4
10	XD0.06.5588G	DADO M6 6S PG 5588 ZINC.	M6 6S BIG LEAD NUT 5588	2
11	XFC.012,5.014	FASCETTA COBRA SL030705	KOBRA CLAMP SL030705	4
12	XFC.013,5.015	FASCETTA COBRA SL030710	KOBRA CLAMP SL030710	4
13	XRP.006.000	RONDELLA PIANA D.6 6592 ZINC.	6mm D. FLAT WASHER	4
14	XTE.006.020T	VITE TE M6X20 5739 ZINC.	BOLT TE M6X20 5739	2

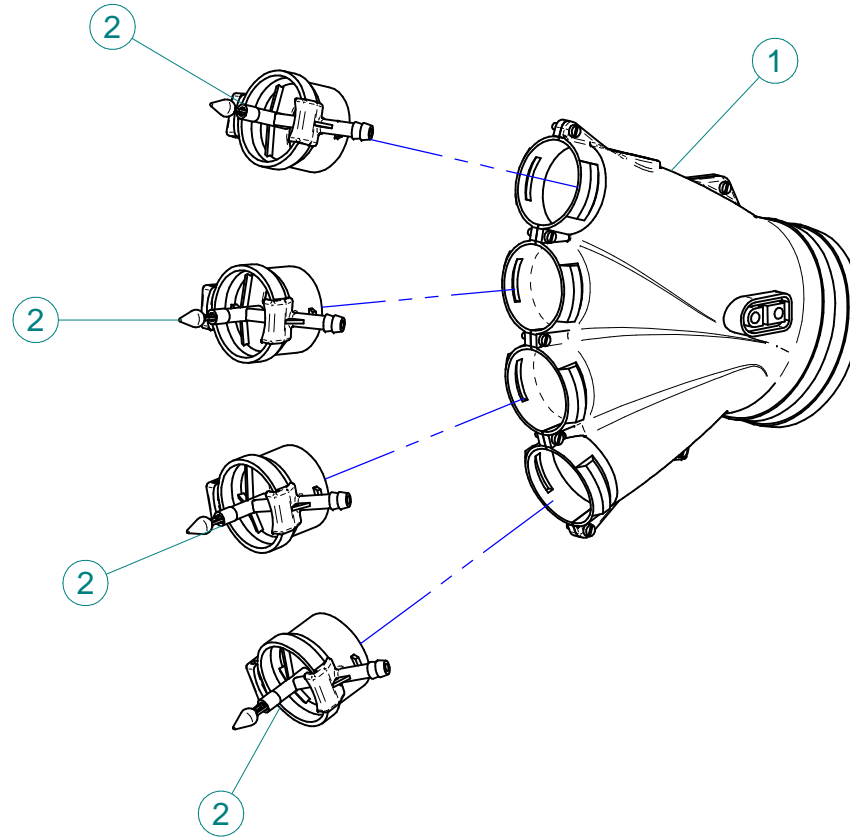

N°	Doc. Number	Titolo	Title	Q.tà
1	X20.014.001DX	MANO A 4 USCITE NUDA	FOUR OUTLETS	1
2	X20.016.01C	RACCORDO ATTACCO RAPIDO PORTA TUBETTO	PIPE WITH OLIVE	4

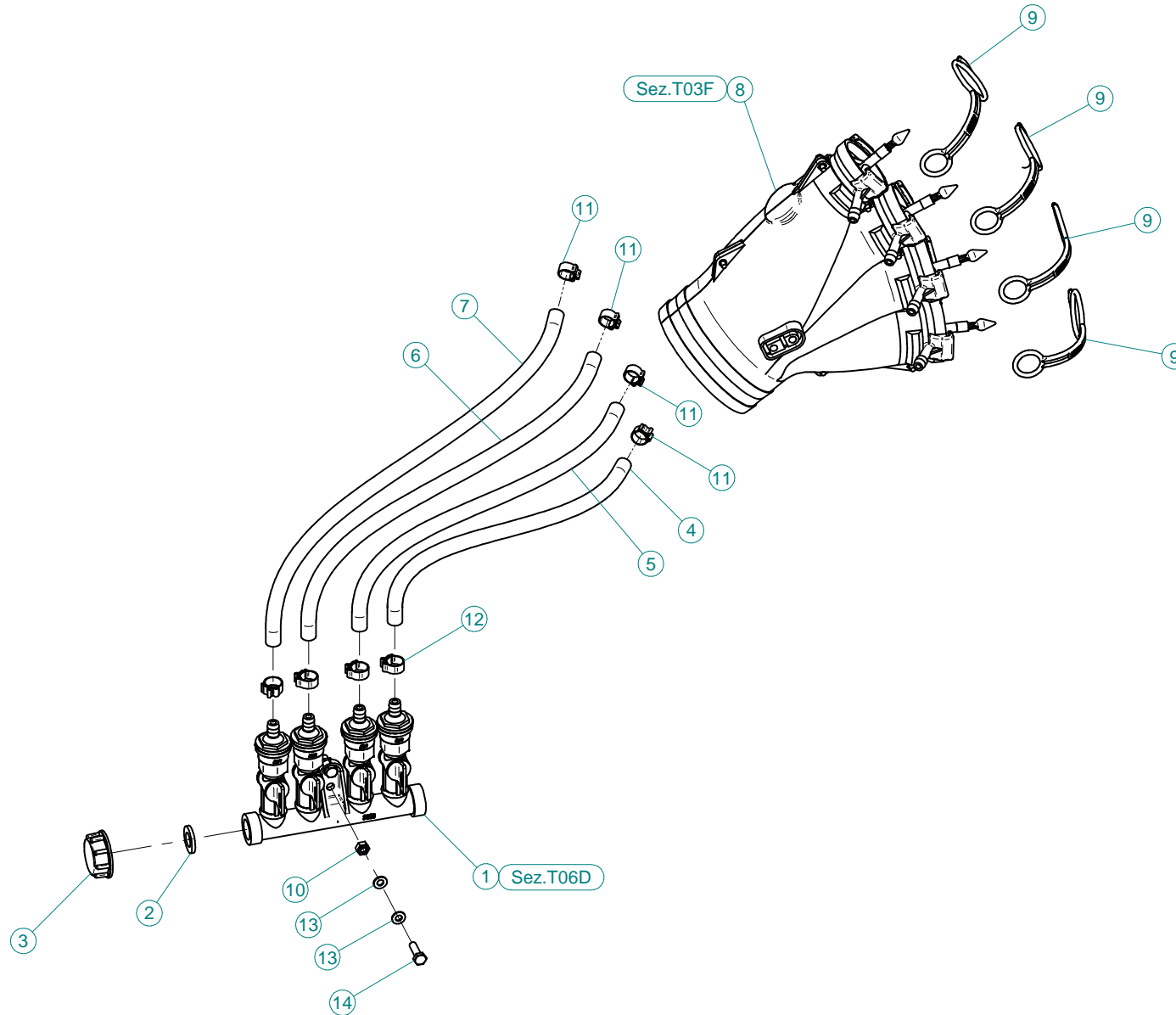

N°	Doc. Number	Titolo	Title	Q.tà
1	X02.008.304C	DISTRIBUTORE LIQUIDI A 4 RUBINETTI CON ANTIGOCCIA	FOUR TAPS LIQUID DISTRIBUTOR WITH ANTI-DRIP DEVICE	1
2	X02.030.010	GUARNIZIONE IN GOMMA D.24X13X3	GASKET D.24X13X3	1
3	X02.182.000	TAPPO 3/4" F.	FEMALE 3/4" CAP	1
4	X02.217.029	TUBO D.8x13 L=290	HOSE D.8x13 L=290	1
5	X02.217.033	TUBO D.8x13 L=330	HOSE D.8x13 L=330	1
6	X02.217.038	TUBO D.8x13 L=380	HOSE D.8x13 L=380	1
7	X02.217.041	TUBO D.8x13 L=410	HOSE D.8x13 L=410	1
8	X20.014.000SX	MANO A 4 USCITE CON TUBETTI	FOUR OUTLETS	1
9	X20.697.000	FERMA DIFFUSORI	NOZZLE STOP	4
10	XD0.06.5588G	DADO M6 6S PG 5588 ZINC.	M6 6S BIG LEAD NUT 5588	2
11	XFC.012,5.014	FASCETTA COBRA SL030705	KOBRA CLAMP SL030705	4
12	XFC.013,5.015	FASCETTA COBRA SL030710	KOBRA CLAMP SL030710	4
13	XRP.006.000	RONDELLA PIANA D.6 6592 ZINC.	6mm D. FLAT WASHER	4
14	XTE.006.020T	VITE TE M6X20 5739 ZINC.	BOLT TE M6X20 5739	2



N°	Doc. Number	Titolo	Title	Q.tà
1	X20.014.001DX	MANO A 4 USCITE NUDA	FOUR OUTLETS	1
2	X20.016.01C	RACCORDO ATTACCO RAPIDO PORTA TUBETTO	PIPE WITH OLIVE	4

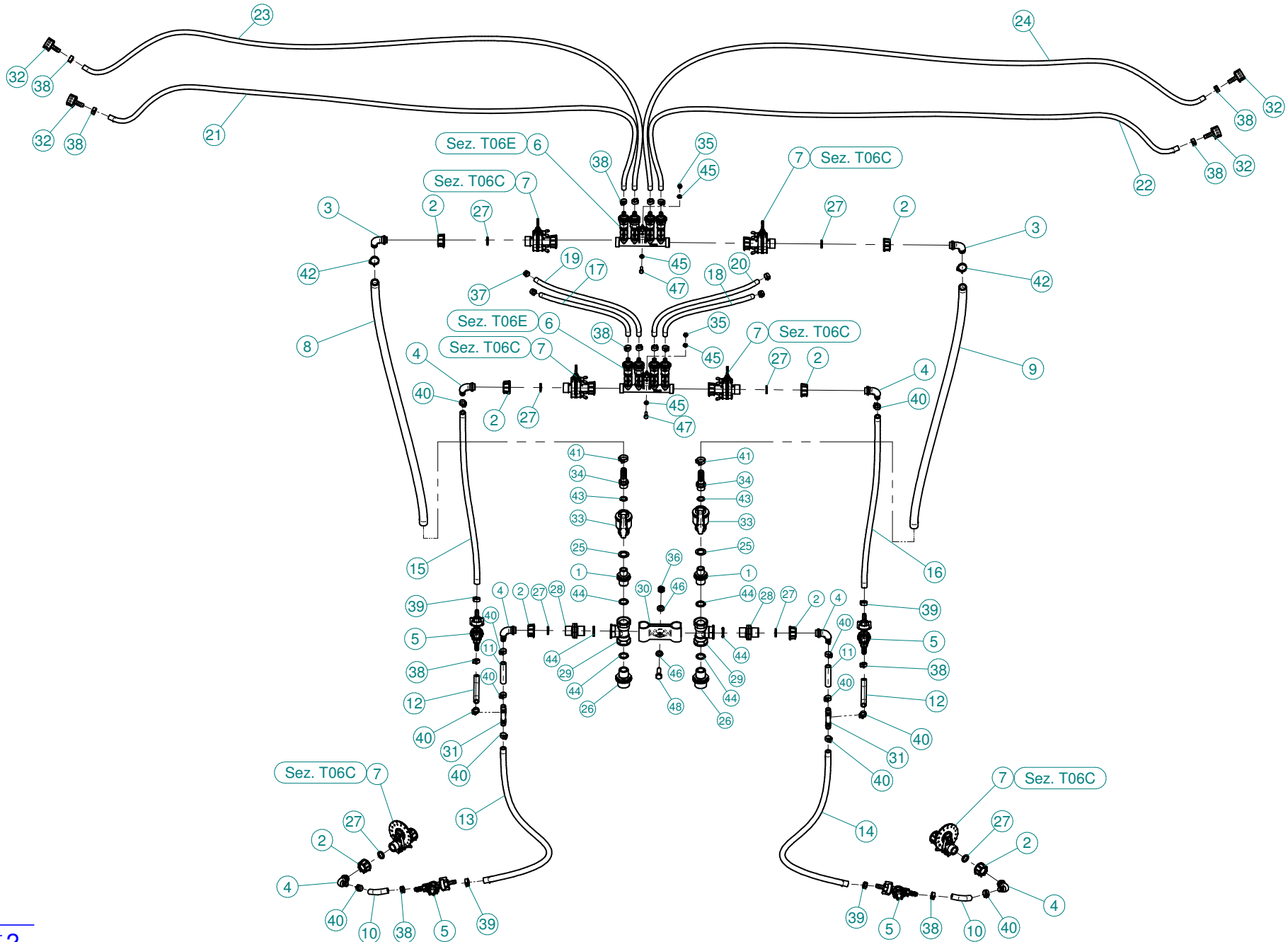

N°	Doc. Number	Titolo	Title	Q.tà	N°	Doc. Number	Titolo	Title	Q.tà
1	X00.055.044	NIPPLO 1/2" GAS 3/4" GAS	NIPPLE 1/2" - 3/4" GAS	2	35	XD0.06.5588G	DADO M6 6S PG 5588 ZINC.	M6 6S BIG LEAD NUT 5588	4
2	X00.055.045	GIRELLO 3/4" GAS ALTO	3/4" GAS FLY NUT	8	36	XDA.010.0BG	DADO AUTOBLOCCANTE M10	SELF LOCKING NUT M10	1
3	X00.055.046	RACCORDO CURVO P.G. Ø16	CURVED UNION WITH R.H. Ø16	2	37	XFC.012.5.014	FASCETTA COBRA SL030705	KOBRA CLAMP SL030705	4
4	X00.055.046R	RACCORDO CURVO P.G. Ø 14	CURVED UNION WITH R.H. D.14	6	38	XFC.013.5.015	FASCETTA COBRA SL030710	KOBRA CLAMP SL030710	16
5	X00.226.05C	GETTO ANTIGOCCIA DIRITTO COMPLETO (0,3 bar)	COMPLETE ANTIDROP (0,3 bar)	4	39	XFC.015.5.017	FASCETTA COBRA SLO30720	KOBRA CLAMP	4
6	X02.008.404C	DISTRIBUTORE LIQUIDI A 4 RUBINETTI	4 TAPS LIQUID MANIFOLD	2	40	XFC.016.5.018	FASCETTA COBRA 16,5 - 18	KOBRA CLAMP 16,5 - 18	12
7	X02.150.000	REGOLATORE A DISCO ROTANTE COMPLETO	ROTATION DISK REGULATION	6	41	XFC.022.5.024	FASCETTA COBRA SLO30756	KOBRA CLAMP SLO30756	2
8	X02.211.095	TUBO Ø16x23 L=950	HOSE Ø16x23 L=950	1	42	XFC.024.5.026	FASCETTA COBRA 24,5 - 26	KOBRA CLAMP 24,5 - 26	2
9	X02.211.095	TUBO Ø16x23 L=950	HOSE Ø16x23 L=950	1	43	XOR.000.121	OR D. 15,88 x 2,62	15,88 x 2,62 O-RING GASKET	2
10	X02.213.007	TUBO Ø10x16 L=70	HOSE Ø10x16 L=70	2	44	XOR.004.081	OR Ø 20,22 x 3,53	20,22 x 3,53 O-RING GASKET	6
11	X02.213.007	TUBO Ø10x16 L=70	HOSE Ø10x16 L=70	2	45	XRP.006.000	RONDELLA PIANA D.6 6592 ZINC.	6mm D. FLAT WASHER	8
12	X02.213.007	TUBO Ø10x16 L=70	HOSE Ø10x16 L=70	2	46	XRP.010.000	RONDELLA PIANA D.10 6592 ZINC.	WASHER Ø 10	2
13	X02.213.060	TUBO Ø10x16 L=600	HOSE Ø10x16 L=600	1	47	XTE.006.020T	VITE TE M6X20 5739 ZINC.	BOLT TE M6X20 5739	4
14	X02.213.060	TUBO Ø10x16 L=600	HOSE Ø10x16 L=600	1	48	XTE.010.035T	VITE TE UNI 5739-65 M10x35-8.8	SCREW TE UNI 5739-65 M10x35-8.8	1
15	X02.213.080	TUBO Ø10x16 L=800	HOSE Ø10x16 L=800	1					
16	X02.213.080	TUBO Ø10x16 L=800	HOSE Ø10x16 L=800	1					
17	X02.217.047	TUBO Ø8x13 L=470	HOSE Ø8x13 L=470	1					
18	X02.217.047	TUBO Ø8x13 L=470	HOSE Ø8x13 L=470	1					
19	X02.217.054	TUBO Ø8x13 L=540	HOSE Ø8x13 L=540	1					
20	X02.217.054	TUBO Ø8x13 L=540	HOSE Ø8x13 L=540	1					
21	X02.217.195	TUBO Ø8x13 L=1950	HOSE Ø8x13 L=1950	1					
22	X02.217.195	TUBO Ø8x13 L=1950	HOSE Ø8x13 L=1950	1					
23	X02.217.215	TUBO Ø8x13 L=2150	HOSE Ø8x13 L=2150	1					
24	X02.217.215	TUBO Ø8x13 L=2150	HOSE Ø8x13 L=2150	1					
25	X02.265.000	GUARNIZIONE PIANA Ø 20/30 x 2,5	PLANE GASKET Ø 20/30 X 2,5	2					
26	X02.293.000	RIDUZIONE 1" M - 3/4" M	1" M - 3/4" M REDUCER NIPPLE	2					
27	X02.349.000	GUARNIZIONE PIANA D.17X23X3	17X23X3 FLAT GASKET (G4000B)	8					
28	X02.380.000	NIPPLO 3/4"	NIPPLE 3/4"	2					
29	X02.396.000	RACCORDO A T 3/4" - 3/4" - 3/4" F.	UNION 3/4" - 3/4" - 3/4" F.	2					
30	X02.999.000	STAFFA FISSAGGIO RACCORDO A T	T UNION FIXING BRACKET	1					
31	X20.885.000	RACCORDO A T Ø13-13-13	T UNION Ø 13-13-13	2					
32	X21.010.000	RACCORDO P.G. DIRITTO Ø 10 COMPLETO	COMPLETE R.H. Ø 10 UNION	4					
33	X21.147.000	VALVOLA A SFERA 1/2" F/F	WAYS VALVE 1/2" F/F	2					
34	X21.151.000	RACCORDO DIRITTO PG D. 16	STRAIGHT HOSE R.H. D. 16	2					



N°	Doc. Number	Titolo	Title	Q.tà
1	X02.147.500	COPPIA DI SEMICORPO REGOLATORE	REGULATOR HALF-BODY	1
2	X02.148.000	DISCO ROTANTE PER REGOLATORE	REGULATOR DISK	1
3	X02.349.000	GUARNIZIONE PIANA D.17X23X3	17X23X3 FLAT GASKET (G4000B)	1
4	XDF.OTT.006	DADO AD ALETTE IN OTTONE M6	BRASS M6 WING NUT	2
5	XOR.002.062	OR D.15,6X1,78	15.6X1.78 O-RING GASKET	2
6	XRP.006.00I	RONDELLA PIANA D.6 INOX	WASHER D.6	2
7	XTE.006.030I	VITE TE M6X30 INOX 5739	BOLT TE M6X30 STAINLESS STEEL 5739	2



N°	Doc. Number	Titolo	Title	Q.tà
1	X00.227.01C	DISPOSITIVO ANTIGOCCIA	ANTI DRIP DEVICE	4
2	X02.008.000	DISTRIBUTORE LIQUIDO TESTATE	SPRAYHEADS LIQUID DISTRIBUTOR	1
3	X20.202.100	RUBINETTO F.1/4" M.18X1,5	TAP ASSEMBLY	4
4	XOR.000.117	OR D.13,1X2,62	13.1X2.62 O-RING GASKET	4

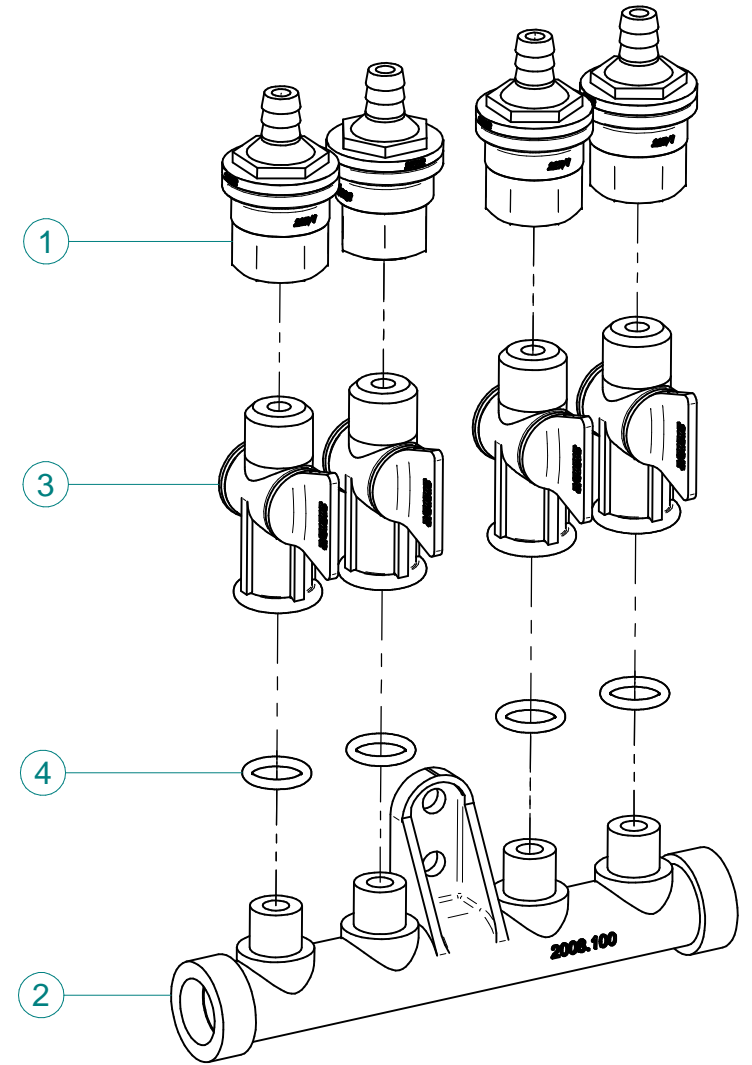
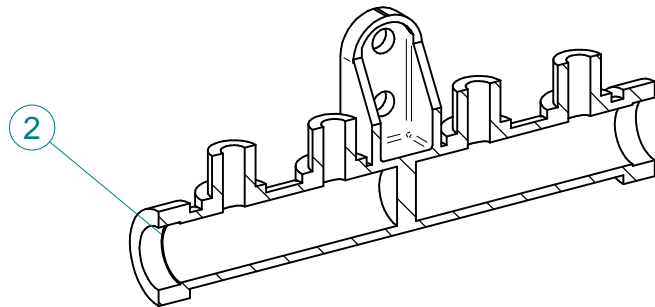

N°	Doc. Number	Titolo	Title	Q.tà
1	X00.227.01C	DISPOSITIVO ANTIGOCCIA	ANTI DRIP DEVICE	4
2	X02.008.100	DISTRIBUTORE LIQUIDO TESTATE DIVISO	SPRAYHEAD LIQUID DISTRIBUTOR	1
3	X20.202.100	RUBINETTO F.1/4" M.18X1,5	TAP ASSEMBLY	4
4	XOR.000.117	OR D.13,1X2,62	13.1X2.62 O-RING GASKET	4

Gli esplosi elencati di seguito sono relativi
a varianti o accessori a richiesta

The exploded drawings listed below are related
to different versions or optional accessories

Le vues éclatées suivantes sont relatives
à des variantes ou à des accessoires optionnels

Dibujos de vista despiezada son relativos a
variantes o accesorios opcionales

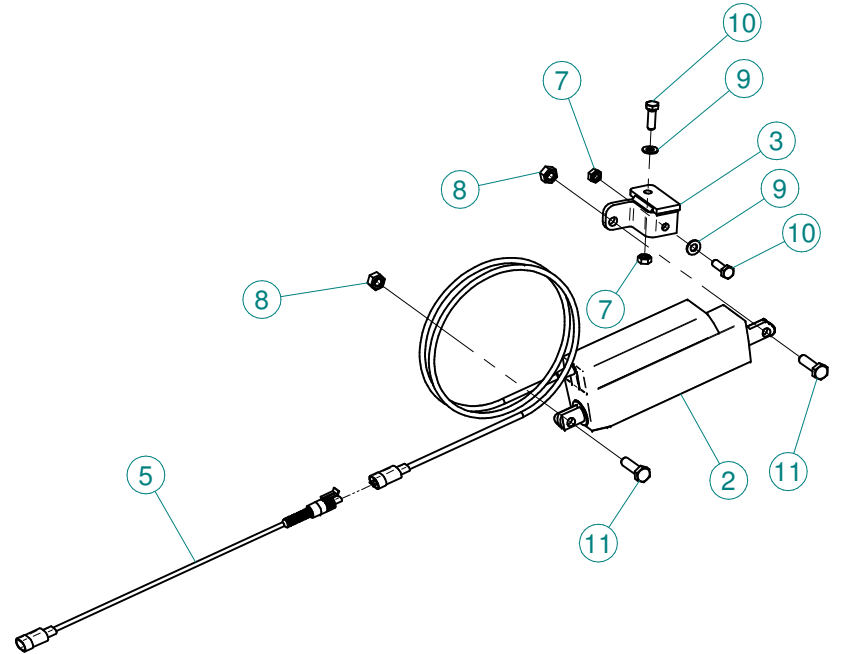
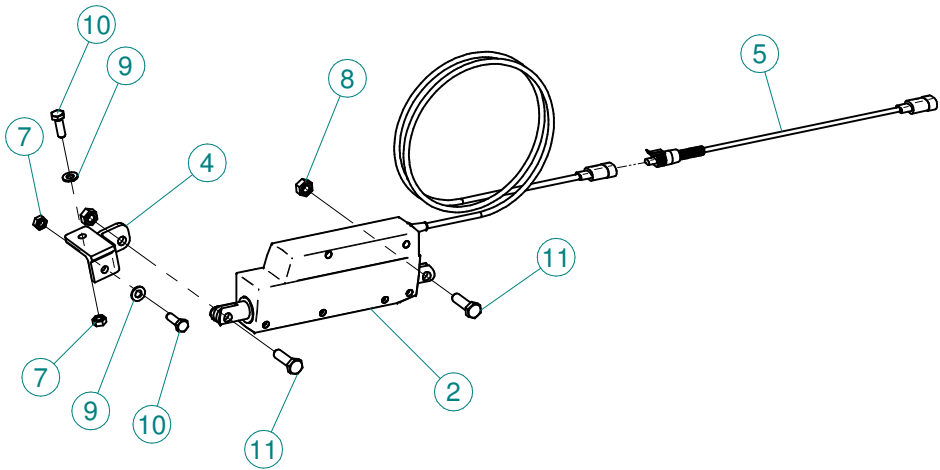
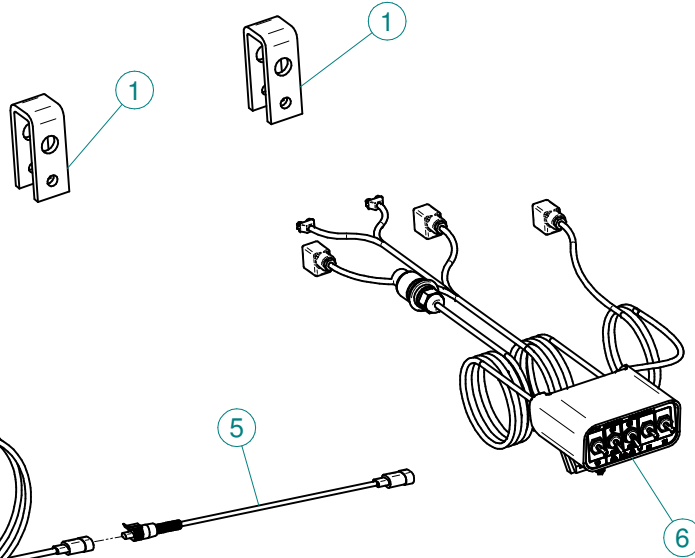
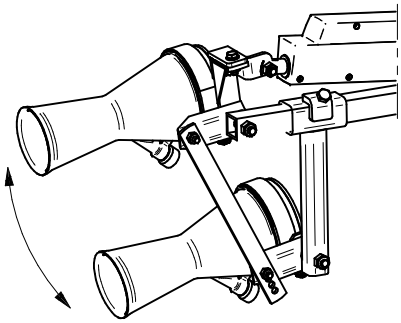

N°	Doc. Number	Titolo	Title	Q.tà
1	X20.742.206	CAVALLOTTO DI TRASCINAMENTO	U BOLT	2
2	X21.016.000	ATTUATORE LINEARE (LA 12.1)	LINEAR ACTUATOR (LA 12.1)	2
3	X21.174.000	STAFFETTA ATTACCO ATTUATORE LINEARE	ACTUATOR BRACKET	1
4	X21.175.000	STAFFETTA ATTACCO ATTUATORE LINEARE	ACTUATOR BRACKET	1
5	X21.474.100	CAVO L=3000 mm COLLEGAMENTO ATTUATORI ELETTRICI	CABLE L=3000 mm ACTUATORS CONNECTION	2
6	X21.530.200	KIT COMANDO ELETTRICO PER PLUS LINK	CONTROL BOX ASSEMBLY FOR PLUS - LINK	1
7	XD0.08.5588G	DADO M8 6S PG 5588 ZINC.	M8 6S BIG LEAD NUT 5588	4
8	XD0.10.5587G	DADO M10 6S PG 5587 ZINC.	M10 6S BIG LEAD NUT 5587	4
9	XRP.008.000	RONDELLA PIANA D.8 6592 ZINC.	8 D. FLAT WASHER	4
10	XTE.008.025T	VITE TE M8X25	BOLT TE M8X25	4
11	XTE.010.035T	VITE TE UNI 5739-65 M10x35-8.8	SCREW TE UNI 5739-65 M10x35-8.8	4



Ø 175
 Plus 42 - 45 - 50
 Blitz 45 - 50
 Link 50



Ø 250
 Plus 55
 Blitz 55
 Link 55