

**Sez. T25 (α)**  
*Movimentazione Elettrica*  
*Electrical Movement*

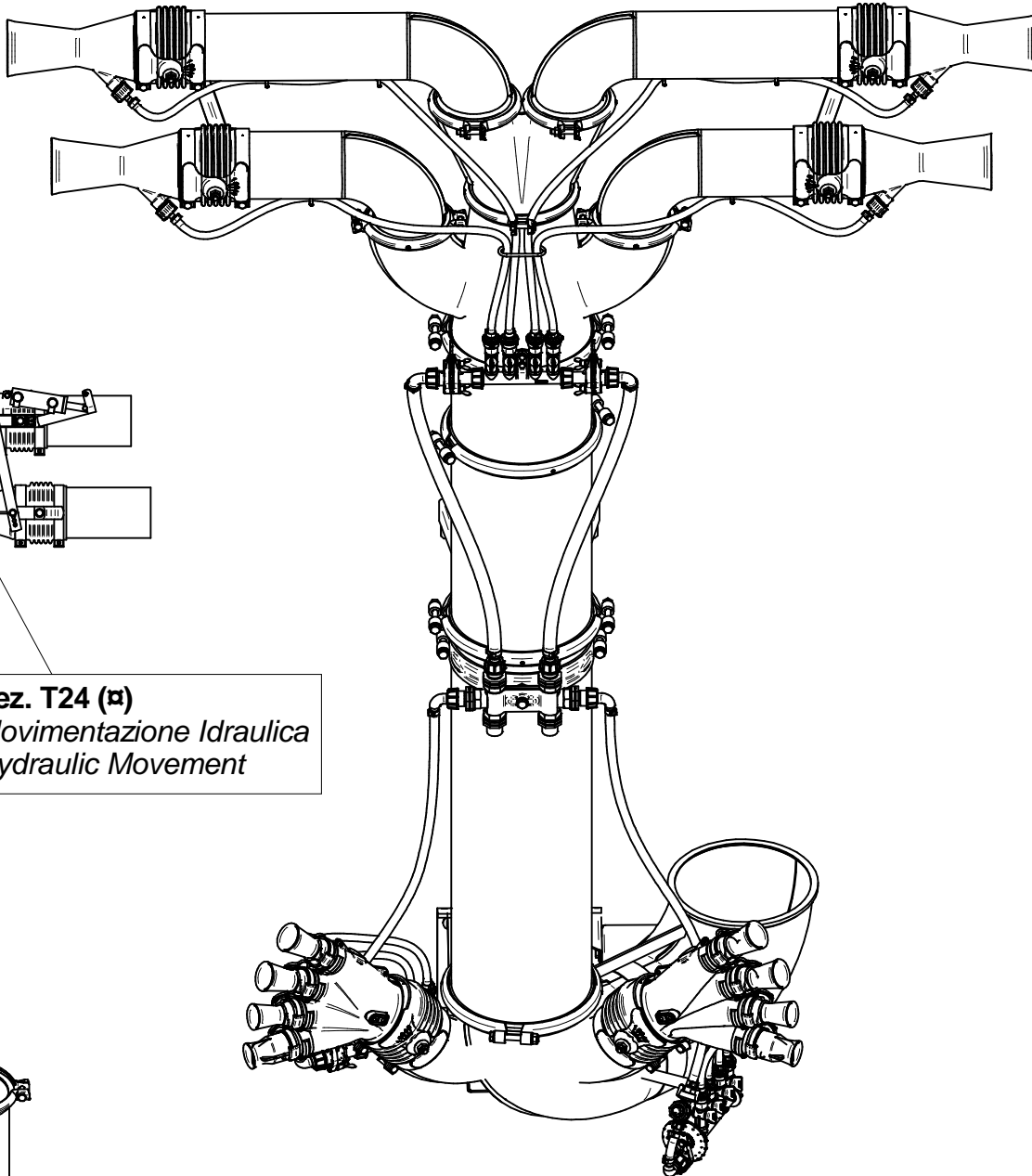

**Sez. T24 (α)**  
*Movimentazione Idraulica*  
*Hydraulic Movement*

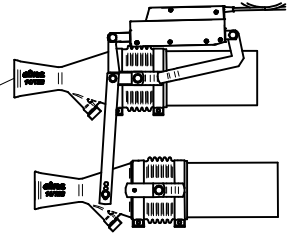
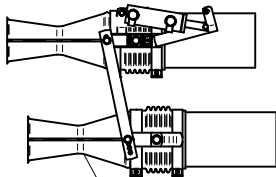

**Sez. T28 (α)**  
*Prolunghe*  
*Extension*

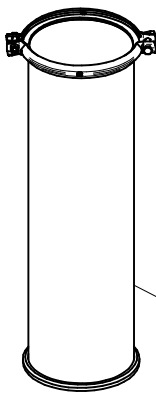

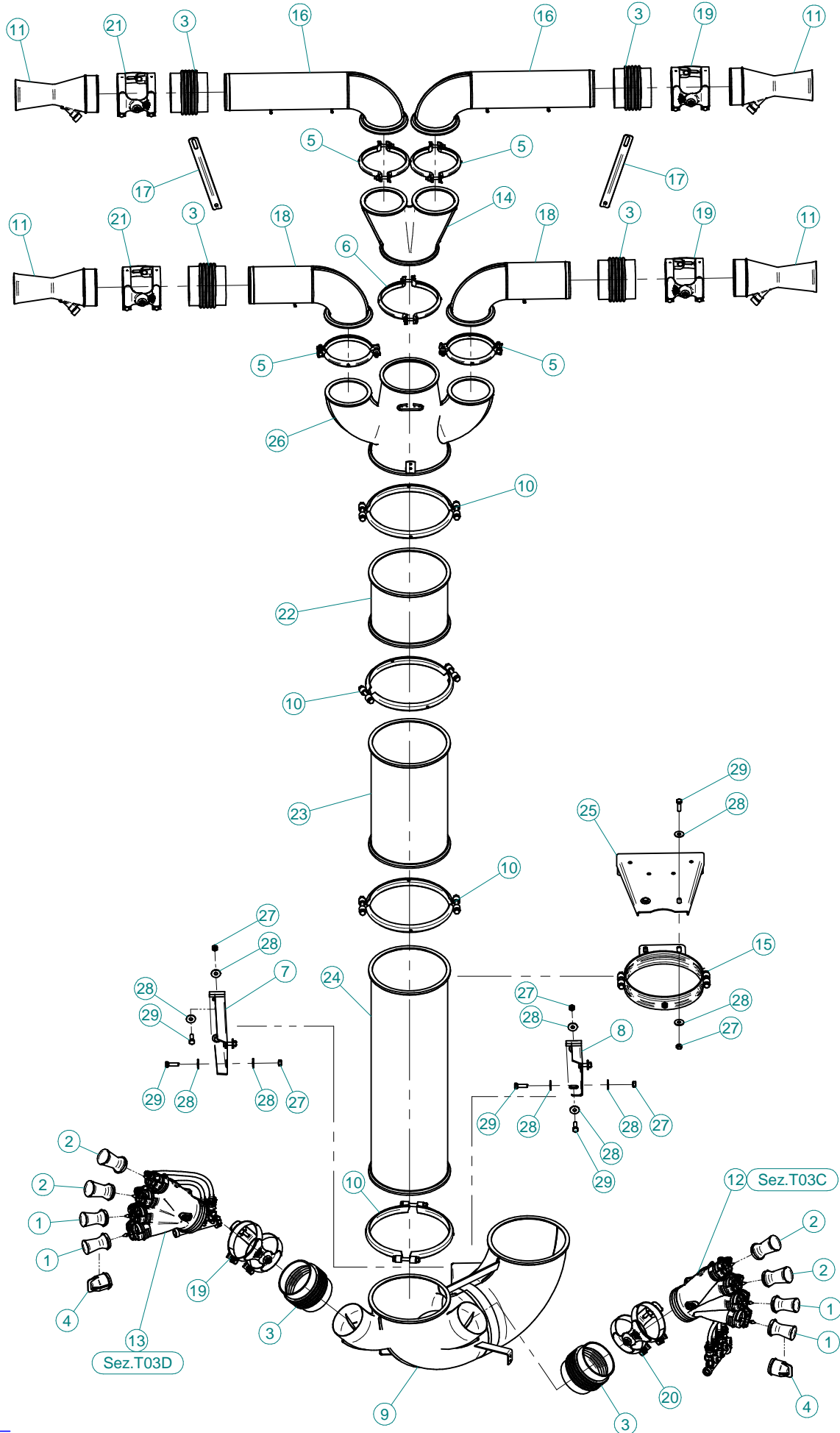

N°	Doc. Number	Titolo	Title	Q.tà
1	X00.006.050	DIFFUSORE 6/50	NOZZLE 6/50	4
2	X00.008.050	DIFFUSORE 8/50	NOZZLE 8/50	4
3	X02.021.000	MANICOTTO FLESSIBILE D.120X120	120 D. FLEXIBLE SLEEVE	6
4	X02.127.000	TAPPO DI ATTACCO RAPIDO	CAP NOZZLE PLUG	2
5	X04.027.000	COLLARE PER TUBI D. 150	PIPE CLAMP D. 150	4
6	X05.616.000	COLLARE PER TUBI Ø 175	PIPE CLAMP Ø 175	1
7	X05.802.251	STAFFA FISSAGGIO CURVA D.250 A 180°	ELBOW FIXING BRACKET	1
8	X05.802.351	STAFFA FISSAGGIO CURVA D.250 A 180°	ELBOW FIXING BRACKET	1
9	X05.802.400	CURVA D.250 A 180° CON 2 USCITE D.120	CURVE D.250 - 180° 2 OUTLETS	1
10	X05.813.000	COLLARE Ø275	CLAMP Ø275	4
11	X10.027.120	DIFFUSORE 27/120 CON TUBETTO	NOZZLE 27/120	4
12	X20.014.704CDX	MANO A 4 USCITE COMPLETA DI DISTRIBUTORE	FOUR NOZZLES DIFFUSER	1
13	X20.014.704CSX	MANO A 4 USCITE COMPLETA DI DISTRIBUTORE	FOUR NOZZLES DIFFUSER	1
14	X20.204.000	CORPO D.175 CON 2 USCITE D.130	BODY D.175 WITH 2 OUTLETS D.130	1
15	X20.504.000	FASCETTA Ø250 FISSAGGIO TESTATE	Ø250 CLAMP HEADS FIXING	1
16	X20.644.102	CURVA D.120 L=520 PER TC	ELBOW D.120 L=520 PER TC	2
17	X20.666.000	STAFFA COLLEGAMENTO DIFFUSORI	NOZZLES UNION BRACKET	2
18	X20.675.000	CURVA D.120 L=330 PER TC	ELBOW D.120 L=330 PER TC	2
19	X21.080.000	COPPIA FASCETTE Ø 127 DESTRA	RIGHT CLAMP Ø 127	3
20	X21.081.000	COPPIA FASCETTE Ø 127 SINISTRA	LEFT CLAMP Ø 127	1
21	X21.081.000	COPPIA FASCETTE Ø 127 SINISTRA	LEFT CLAMP Ø 127	2
22	X21.100.020	PROLUNGA D.250 x 200	EXTENSION D.250 x 200	1
23	X21.100.040	PROLUNGA D.250 x 400	EXTENSION D.250 x 400	1
24	X21.100.080	PROLUNGA D.250 X 800 MM.	250mm INTERNAL D.800mm LENGTH	1
25	X40.208.200	STAFFA COMPLETA DI FISSAGGIO	FIXING BRACKET	1
26	X50.078.000	CORPO D.250-175 CON DUE USCITE D.130	BODY D.250-175 WITH 2 OUTLETS D.130	1
27	XD0.10.5587G	DADO M10 6S PG 5587 ZINC.	M10 6S BIG LEAD NUT 5587	12
28	XRP.010.030	RONDELLA PIANA F.LARGA D.10X30 ZINC.	10X30mm D. LARGE THREAD FLAT	24
29	XTE.010.035T	VITE TE UNI 5739-65 M10x35-8.8	SCREW TE UNI 5739-65 M10x35-8.8	12

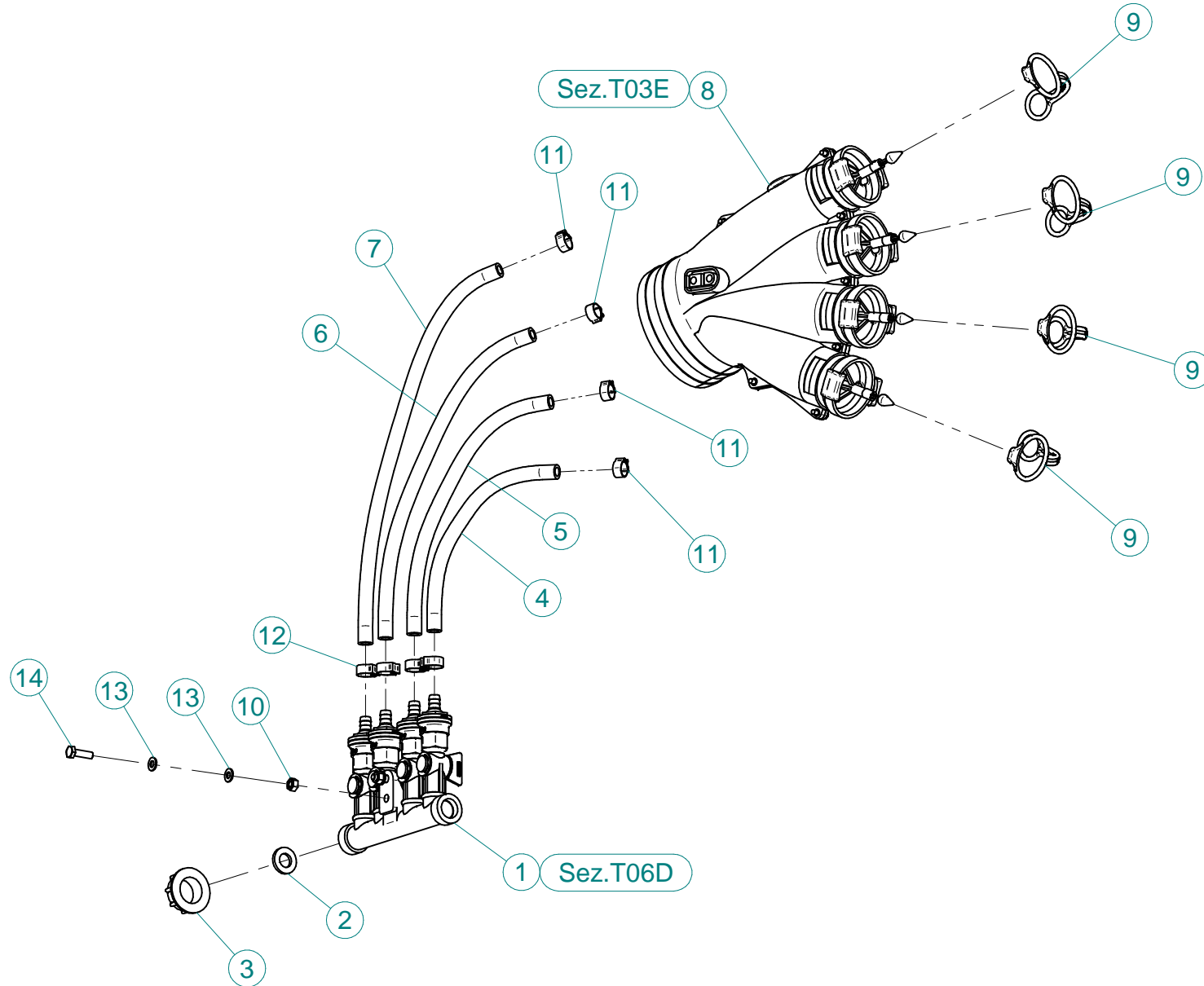

N°	Doc. Number	Titolo	Title	Q.tà
1	X02.008.304C	DISTRIBUTORE LIQUIDI A 4 RUBINETTI CON ANTIGOCCIA	FOUR TAPS LIQUID DISTRIBUTOR WITH ANTI-DRIP DEVICE	1
2	X02.030.010	GUARNIZIONE IN GOMMA D.24X13X3	GASKET D.24X13X3	1
3	X02.182.000	TAPPO 3/4" F.	FEMALE 3/4" CAP	1
4	X02.217.023	TUBO D.8x13 L=230	HOSE D.8x13 L=230	1
5	X02.217.028	TUBO D.8x13 L=280	HOSE D.8x13 L=280	1
6	X02.217.034	TUBO D.8x13 L=340	HOSE D.8x13 L=340	1
7	X02.217.037	TUBO D.8x13 L=370	HOSE D.8x13 L=370	1
8	X20.014.000DX	MANO A 4 USCITE CON TUBETTI	FOUR OUTLETS	1
9	X20.697.000	FERMA DIFFUSORI	NOZZLE STOP	4
10	XD0.06.5588G	DADO M6 6S PG 5588 ZINC.	M6 6S BIG LEAD NUT 5588	2
11	XFC.012,5.014	FASCETTA COBRA SL030705	KOBRA CLAMP SL030705	4
12	XFC.013,5.015	FASCETTA COBRA SL030710	KOBRA CLAMP SL030710	4
13	XRP.006.000	RONDELLA PIANA D.6 6592 ZINC.	6mm D. FLAT WASHER	4
14	XTE.006.020T	VITE TE M6X20 5739 ZINC.	BOLT TE M6X20 5739	2

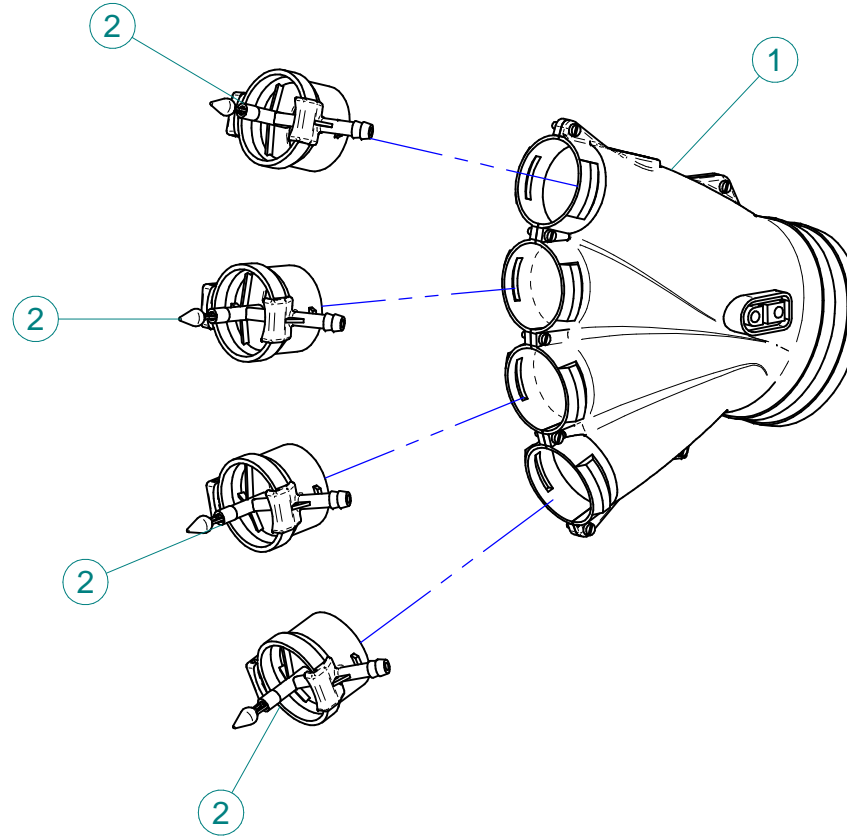

N°	Doc. Number	Titolo	Title	Q.tà
1	X20.014.001DX	MANO A 4 USCITE NUDA	FOUR OUTLETS	1
2	X20.016.01C	RACCORDO ATTACCO RAPIDO PORTA TUBETTO	PIPE WITH OLIVE	4

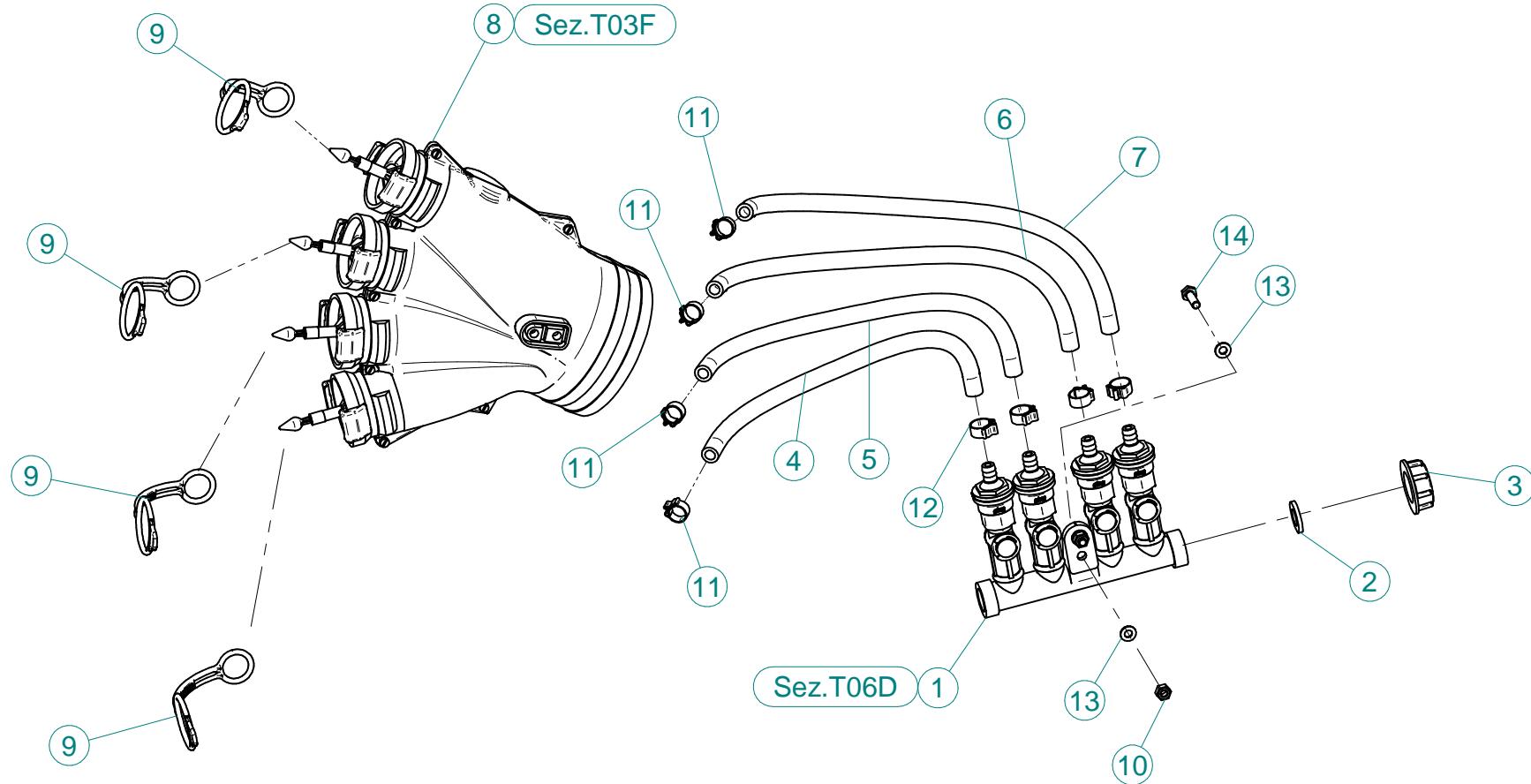

N°	Doc. Number	Titolo	Title	Q.tà
1	X02.008.304C	DISTRIBUTORE LIQUIDI A 4 RUBINETTI CON ANTIGOCCIA	FOUR TAPS LIQUID DISTRIBUTOR WITH ANTI-DRIP DEVICE	1
2	X02.030.010	GUARNIZIONE IN GOMMA D.24X13X3	GASKET D.24X13X3	1
3	X02.182.000	TAPPO 3/4" F.	FEMALE 3/4" CAP	1
4	X02.217.028	TUBO D.8X13 L=280	HOSE D. 8X13 L=280	1
5	X02.217.032	TUBO D.8X13 L=320	HOSE D.8X13 L=320	1
6	X02.217.037	TUBO D.8X13 L=370	HOSE D.8X13 L=370	1
7	X02.217.040	TUBO D.8X13 L=400	HOSE D.8X13 L=400	1
8	X20.014.000SX	MANO A 4 USCITE CON TUBETTI	FOUR OUTLETS	1
9	X20.697.000	FERMA DIFFUSORI	NOZZLE STOP	4
10	XD0.06.5588G	DADO M6 6S PG 5588 ZINC.	M6 6S BIG LEAD NUT 5588	2
11	XFC.012,5.014	FASCETTA COBRA SL030705	KOBRA CLAMP SL030705	4
12	XFC.013,5.015	FASCETTA COBRA SL030710	KOBRA CLAMP SL030710	4
13	XRP.006.000	RONDELLA PIANA D.6 6592 ZINC.	6mm D. FLAT WASHER	4
14	XTE.006.020T	VITE TE M6X20 5739 ZINC.	BOLT TE M6X20 5739	2



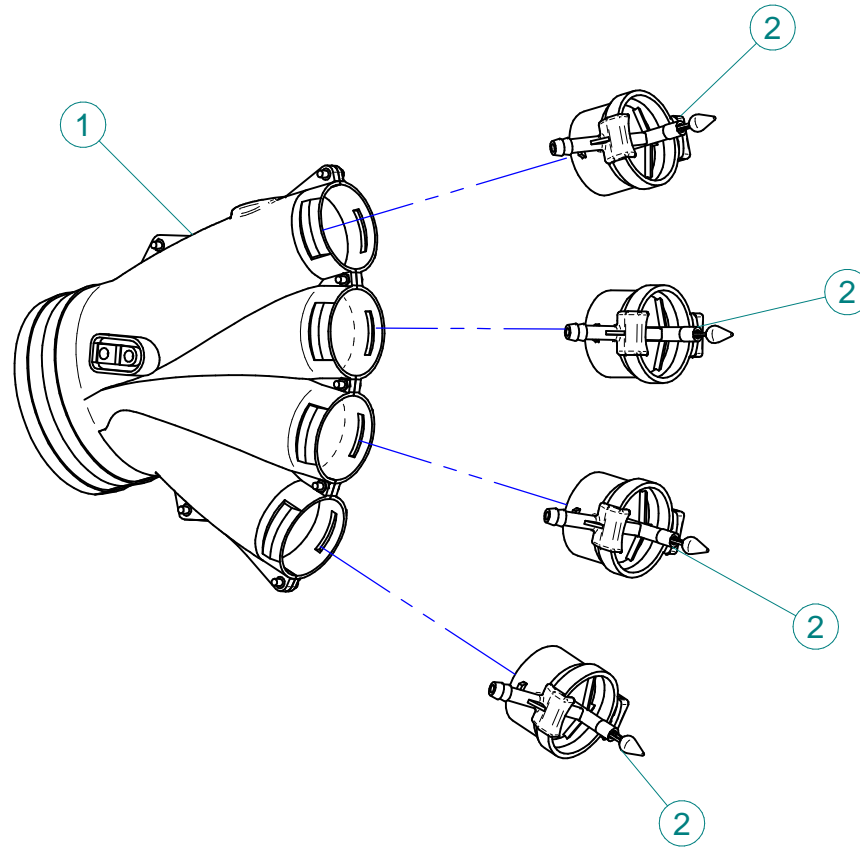

N°	Doc. Number	Titolo	Title	Q.tà
1	X20.014.001DX	MANO A 4 USCITE NUDA	FOUR OUTLETS	1
2	X20.016.01C	RACCORDO ATTACCO RAPIDO PORTA TUBETTO	PIPE WITH OLIVE	4

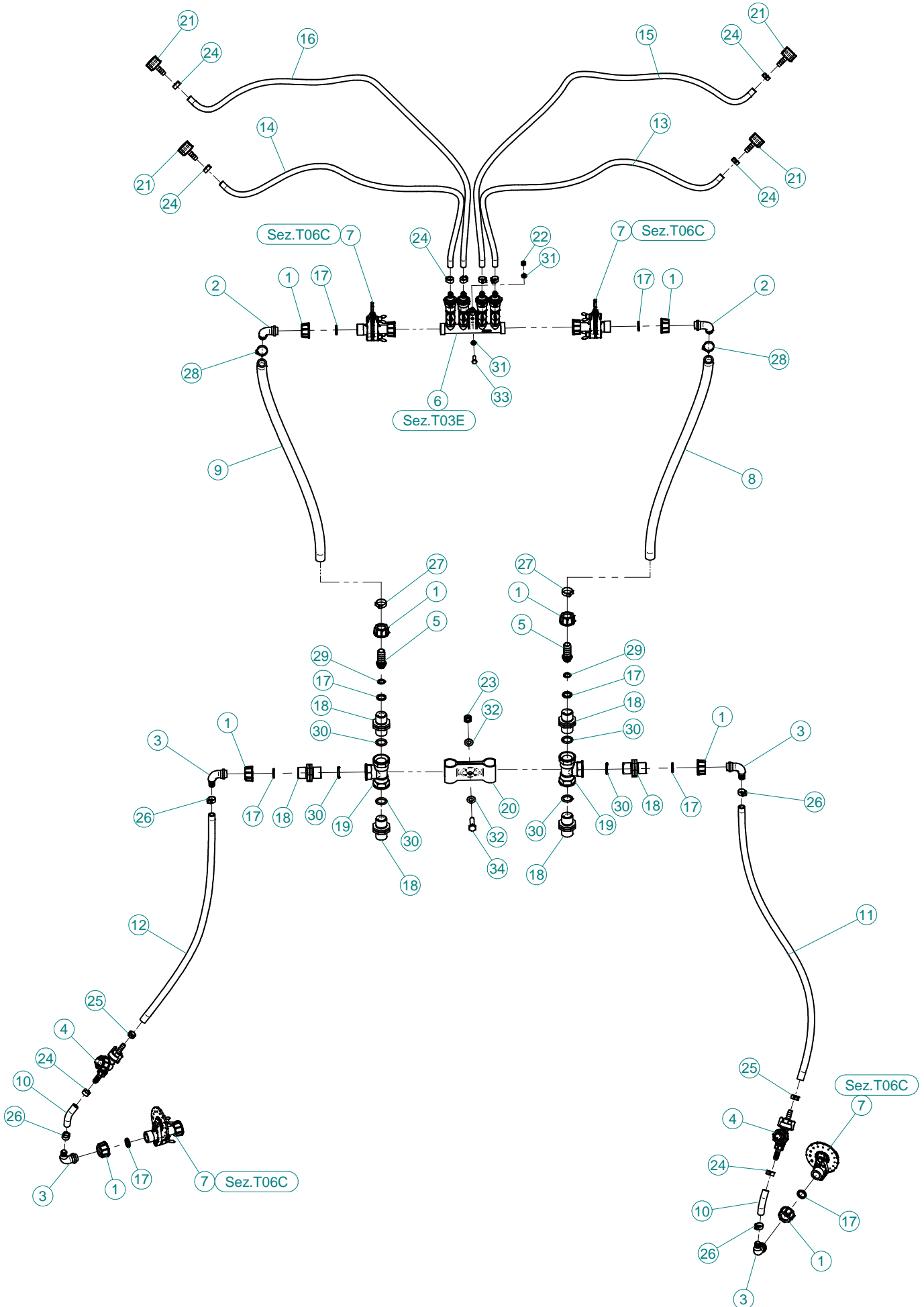

N°	Doc. Number	Titolo	Title	Q.tà
1	X00.055.045	GIRELLO 3/4" GAS ALTO	3/4" GAS FLY NUT	8
2	X00.055.046	RACCORDO CURVO P.G. Ø17	CURVED UNION WITH R.H. Ø17	2
3	X00.055.046R	RACCORDO CURVO P.G. Ø 14	CURVED UNION WITH R.H. D.14	4
4	X00.226.05C	GETTO ANTIGOCCIA DIRITTO COMPLETO (0,3 bar)	COMPLETE ANTIDROP (0,3 bar)	2
5	X02.002.000	RACCORDO DIRITTO 3/4" P.G.16	STRAIGHT UNION 3/4" R.H.16	2
6	X02.008.404C	DISTRIBUTORE LIQUIDI A 4 RUBINETTI	4 TAPS LIQUID MANIFOLD	1
7	X02.150.000	REGOLATORE A DISCO ROTANTE COMPLETO	ROTATION DISK REGULATION	4
8	X02.211.065	TUBO Ø16x23 L= 650	HOSE Ø16x23 L= 650	1
9	X02.211.065	TUBO Ø16x23 L= 650	HOSE Ø16x23 L= 650	1
10	X02.213.007	TUBO Ø10x16 L=70	HOSE Ø10x16 L=70	2
11	X02.213.090	TUBO Ø 10x16 L=900	HOSE Ø 10x16 L=900	1
12	X02.213.090	TUBO Ø 10x16 L=900	HOSE Ø 10x16 L=900	1
13	X02.217.100	TUBO Ø8x13 L=1000	HOSE Ø8x13 L=1000	1
14	X02.217.100	TUBO Ø8x13 L=1000	HOSE Ø8x13 L=1000	1
15	X02.217.120	TUBO Ø8x13 L=1200	HOSE Ø8x13 L=1200	1
16	X02.217.120	TUBO Ø8x13 L=1200	HOSE Ø8x13 L=1200	1
17	X02.349.000	GUARNIZIONE PIANA D.17X23X3	17X23X3 FLAT GASKET (G4000B)	8
18	X02.380.000	NIPPLO 3/4"	NIPPLE 3/4"	6
19	X02.396.000	RACCORDO A T 3/4" - 3/4" - 3/4" F.	UNION 3/4" - 3/4" - 3/4" F.	2
20	X02.999.000	STAFFA FISSAGGIO RACCORDO A T	T UNION FIXING BRACKET	1
21	X21.010.000	RACCORDO P.G. DIRITTO Ø 10 COMPLETO	COMPLETE R.H. Ø 10 UNION	4
22	XD0.06.5588G	DADO M6 6S PG 5588 ZINC.	M6 6S BIG LEAD NUT 5588	2
23	XDA.010.0BG	DADO AUTOBLOCCANTE M10	SELF LOCKING NUT M10	1
24	XFC.013,5.015	FASCETTA COBRA SL030710	KOBRA CLAMP SL030710	10
25	XFC.015,5.017	FASCETTA COBRA SLO30720	KOBRA CLAMP	2
26	XFC.016,5.018	FASCETTA COBRA 16,5 - 18	KOBRA CLAMP 16,5 - 18	4
27	XFC.022,5.024	FASCETTA COBRA SLO30756	KOBRA CLAMP SLO30756	2
28	XFC.023,5.025	FASCETTA COBRA SLO30761	KOBRA CLAMP SLO30761	2
29	XOR.000.117	OR D.13,1X2,62	13.1X2.62 O-RING GASKET	2
30	XOR.004.081	OR Ø 20,22 x 3,53	20,22 x 3,53 O-RING GASKET	6
31	XRP.006.000	RONDELLA PIANA D.6 6592 ZINC.	6mm D. FLAT WASHER	4
32	XRP.010.000	RONDELLA PIANA D.10 6592 ZINC.	WASHER Ø 10	2
33	XTE.006.020T	VITE TE M6X20 5739 ZINC.	BOLT TE M6X20 5739	2
34	XTE.010.035T	VITE TE UNI 5739-65 M10x35-8.8	SCREW TE UNI 5739-65 M10x35-8.8	1

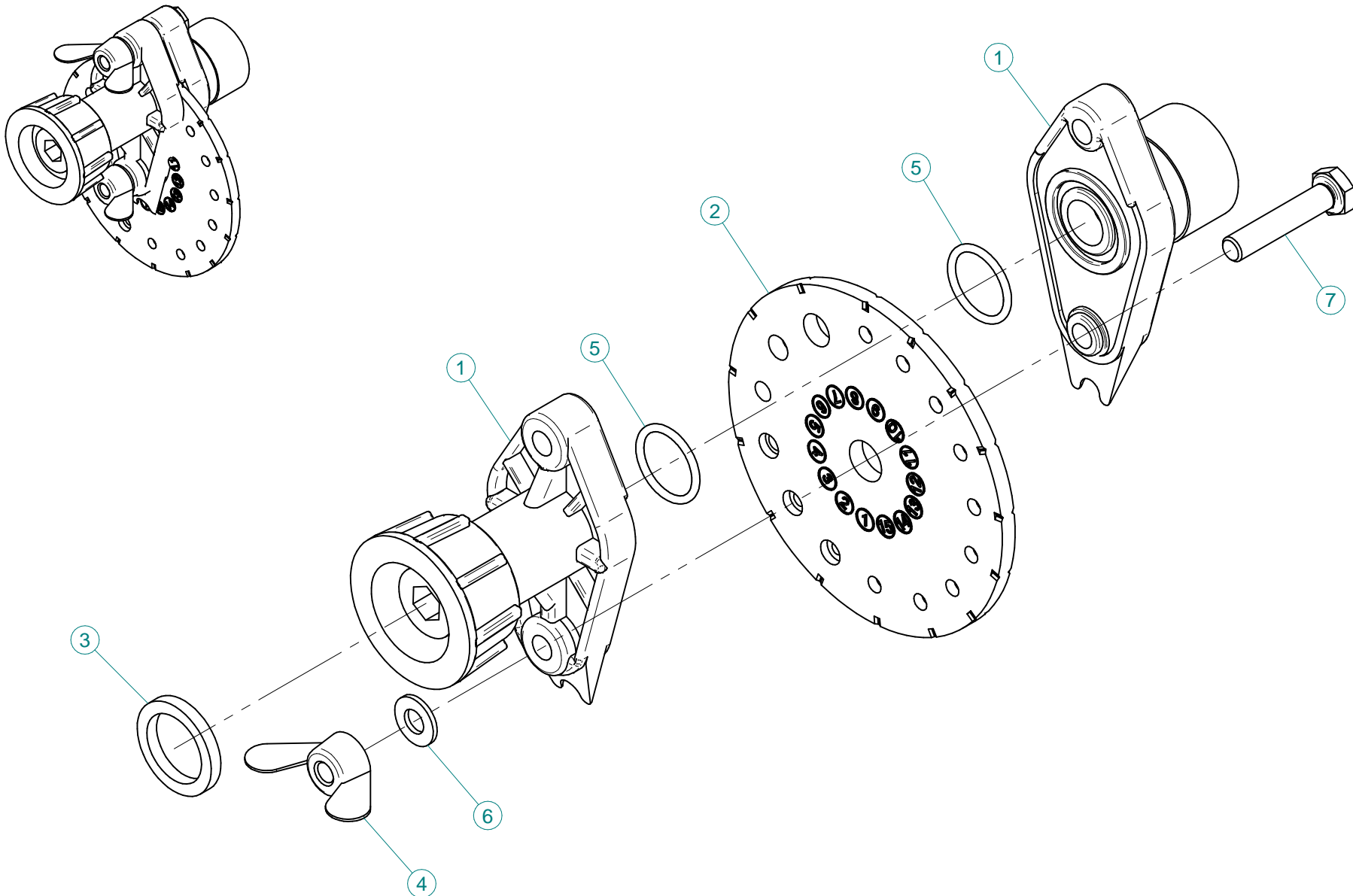

N°	Doc. Number	Titolo	Title	Q.tà
1	X02.147.500	COPPIA DI SEMICORPO REGOLATORE	REGULATOR HALF-BODY	1
2	X02.148.000	DISCO ROTANTE PER REGOLATORE	REGULATOR DISK	1
3	X02.349.000	GUARNIZIONE PIANA D.17X23X3	17X23X3 FLAT GASKET (G4000B)	1
4	XDF.OTT.006	DADO AD ALETTE IN OTTONE M6	BRASS M6 WING NUT	2
5	XOR.002.062	OR D.15,6X1,78	15.6X1.78 O-RING GASKET	2
6	XRP.006.00I	RONDELLA PIANA D.6 INOX	WASHER D.6	2
7	XTE.006.030I	VITE TE M6X30 INOX 5739	BOLT TE M6X30 STAINLESS STEEL 5739	2

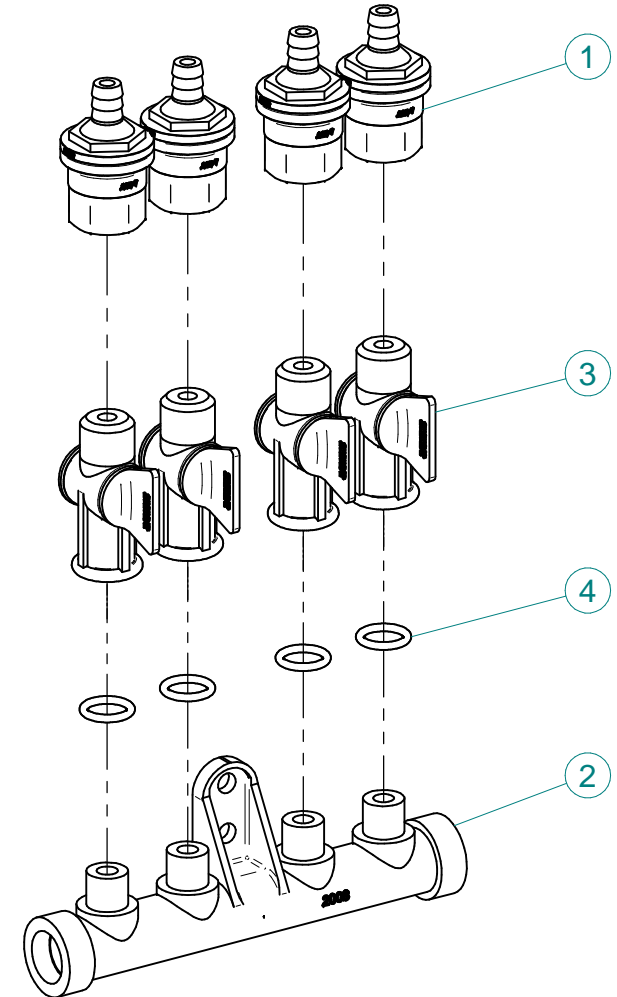
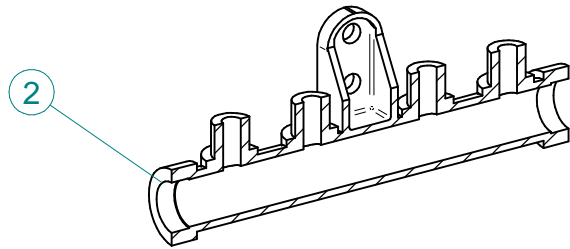

N°	Doc. Number	Titolo	Title	Q.tà
1	X00.227.01C	DISPOSITIVO ANTIGOCCIA	ANTI DRIP DEVICE	4
2	X02.008.000	DISTRIBUTORE LIQUIDO TESTATE	SPRAYHEADS LIQUID DISTRIBUTOR	1
3	X20.202.100	RUBINETTO F.1/4" M.18X1,5	TAP ASSEMBLY	4
4	XOR.000.117	OR D.13,1X2,62	13.1X2.62 O-RING GASKET	4

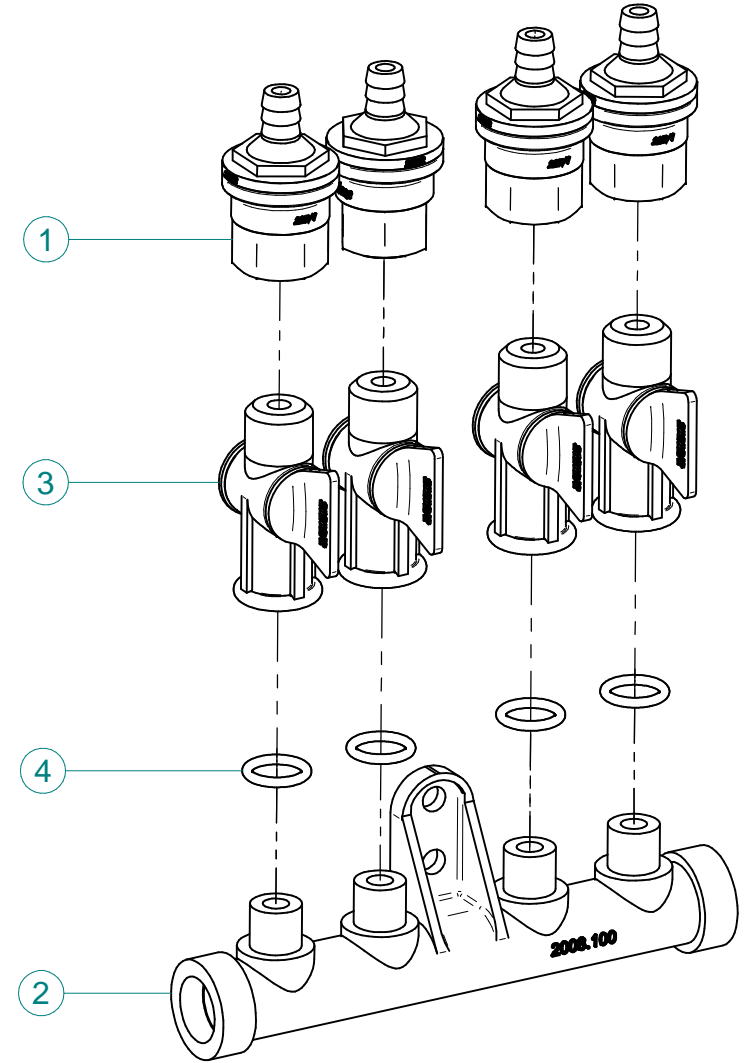
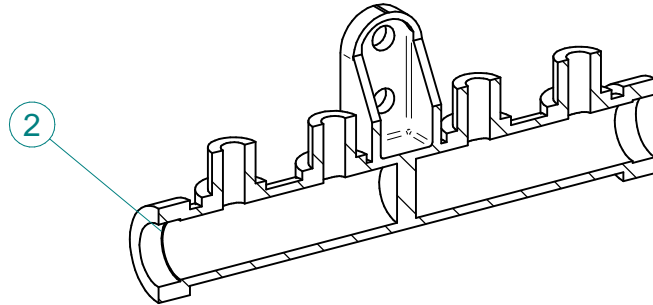

N°	Doc. Number	Titolo	Title	Q.tà
1	X00.227.01C	DISPOSITIVO ANTIGOCCIA	ANTI DRIP DEVICE	4
2	X02.008.100	DISTRIBUTORE LIQUIDO TESTATE DIVISO	SPRAYHEAD LIQUID DISTRIBUTOR	1
3	X20.202.100	RUBINETTO F.1/4" M.18X1,5	TAP ASSEMBLY	4
4	XOR.000.117	OR D.13,1X2,62	13.1X2.62 O-RING GASKET	4

Gli esplosi elencati di seguito sono relativi  
a varianti o accessori a richiesta

The exploded drawings listed below are related  
to different versions or optional accessories

Le vues éclatées suivantes sont relatives  
à des variantes ou à des accessoires optionnels

Dibujos de vista despiezada son relativos a  
variantes o accesorios opcionales



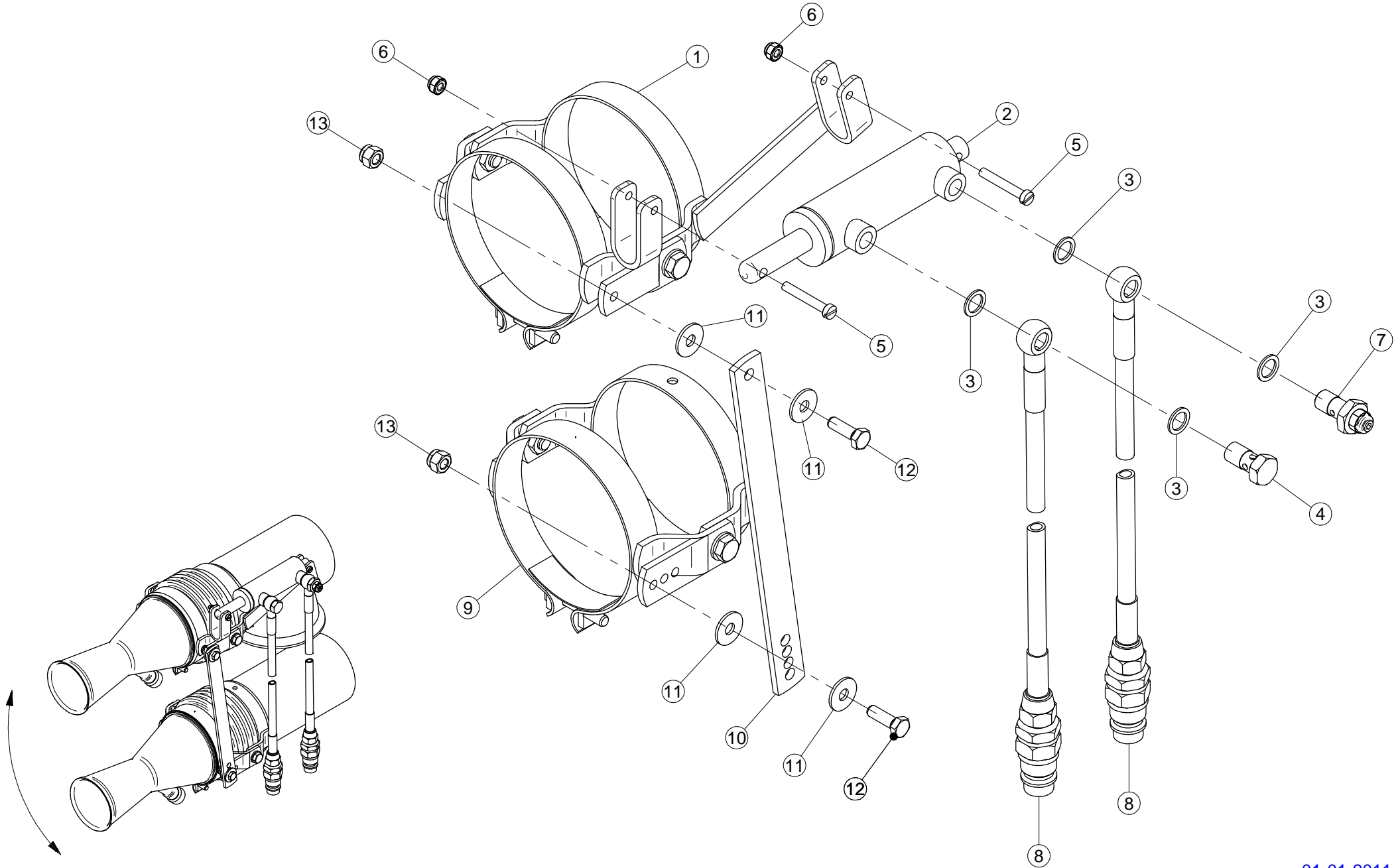

N°	Doc. Number	Titolo	Title	Q.tà	Note
1	X02.140.200	COPPIA FASCETTE ORIENTABILI D.127 CON ATTACCO PISTONE	CLAMP D.127 WITH JACK BRACKET	2	
2	X02.840.04C	MARTINETTO COMPLETO D.20/30 CORSA 60	JACK	2	
3	X02.472.000	RONDELLA DI RAME Ø 19x13,5x1,5	COPPER WASHER Ø 19x13,5x1,5	8	
4	X02.408.000	RACCORDO DRITTO PER OCCHIO 1/4"	JACK EYE RIGHT UNION 1/4"	2	
5	XTC.06.40.07I	VITE T.CIL. M6 x 40 INOX	INOX SCREW M6 x 40	4	
6	XDA.006.0AG	DADO AUTOBLOCCANTE M6	SELF LOCKING NUT M6	4	
7	X20.718.000	REGOLATORE PORTATA IDRAULICA 1/4"	FLOW REGULATOR 1/4"	2	
8	X20.900.370	TUBO OLIO PER MARTINETTO L=3700	OIL PIPE FOR JACK L=3700	4	
9	X02.140.020	COPPIA FASCETTE ORIENTABILI D.127	CANNON SPRAYER CLAMP D.127	2	
10	X20.922.000	STAFFA COLLEGAMENTO PER DIFF.MOVIM. IDRAULICA	UNION BRACKET	2	
11	XRP.008.024	RONDELLA PIANA F.LARGA D.8X24 ZINC.	WASHER D.8X24	8	
12	XTE.008.025T	VITE TE M8X25 5739	BOLT TE M8X25 5739	4	
13	XDA.008.0AG	DADO AUTOBLOCCANTE M8 ALTO PG ZINC.	HIGH BIG LEAD M8 SELFLOCKING	4	

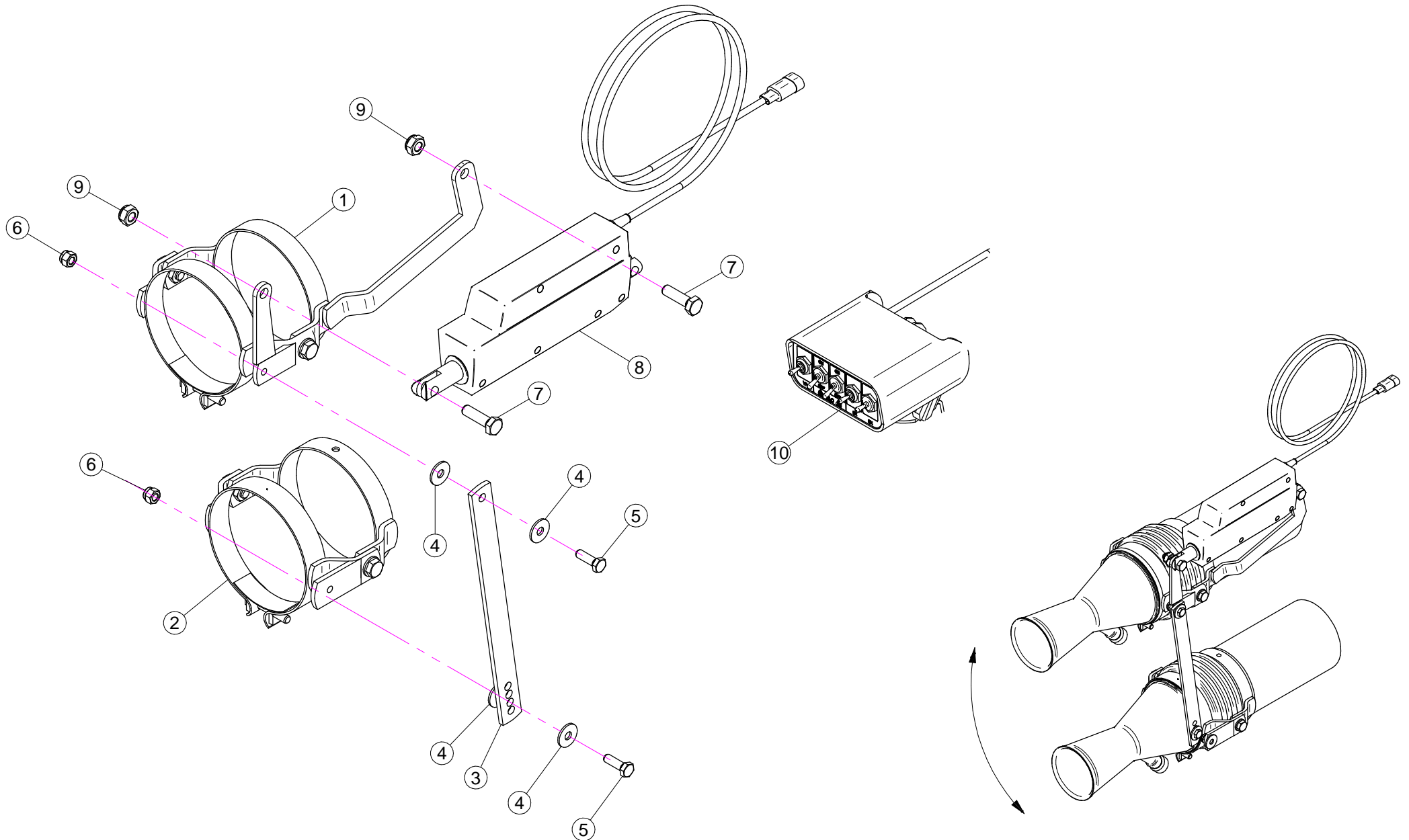

N°	Doc. Number	Titolo	Title	Q.tà	Note
1	X02.140.500	COPPIA FASCETTE ORIENTABILI D.127 CON ATTACCO ATTUATORE	CLAMP D.127 WITH ACTUATOR BRACKET	2	
2	X02.140.020	COPPIA FASCETTE ORIENTABILI D.127	CANNON SPRAYER CLAMP D.127	2	
3	X20.922.000	STAFFA COLLEGAMENTO PER DIFF.MOVIM. IDRAULICA	UNION BRACKET	2	
4	XRP.008.024	RONDELLA PIANA F.LARGA D.8X24 ZINC.	WASHER D.8X24	8	
5	XTE.008.025T	VITE TE M8X25 5739	BOLT TE M8X25 5739	4	
6	XDA.008.0AG	DADO AUTOBLOCCANTE M8 ALTO PG ZINC.	HIGH BIG LEAD M8 SELFLOCKING	4	
7	XTE.010.035T	VITE TE UNI 5739-65 M10x35-8.8	SCREW TE UNI 5739-65 M10x35-8.8	4	
8	X21.016.000	ATTUATORE LINEARE (LA 12.1)	LINEAR ACTUATOR (LA 12.1)	2	
9	XDA.010.0BG	DADO AUTOBLOCCANTE M10	SELF LOCKING NUT M10	4	
10	X21.030.200	KIT COMANDO ELETTRICO ( ATTUATORI / ELETROVALVOLE)	KIT REMOTE CONTROL ( LINEAR ACTUATOR / SOLENOID VALVE )	1	

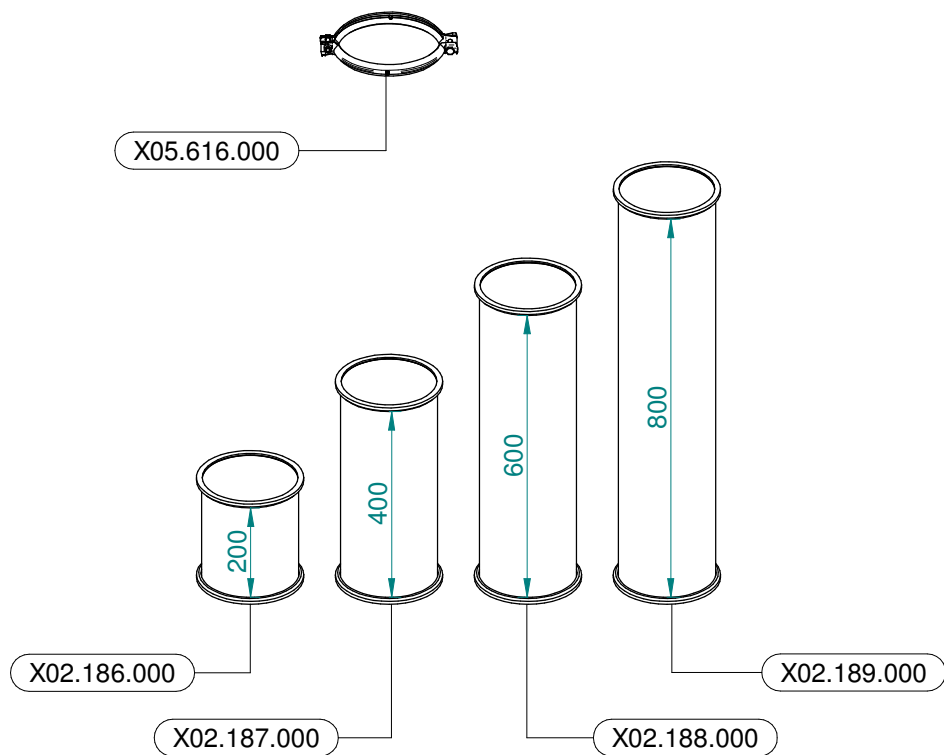

**Ø 175**  
 Plus 42 - 45 - 50  
 Blitz 45 - 50  
 Link 50

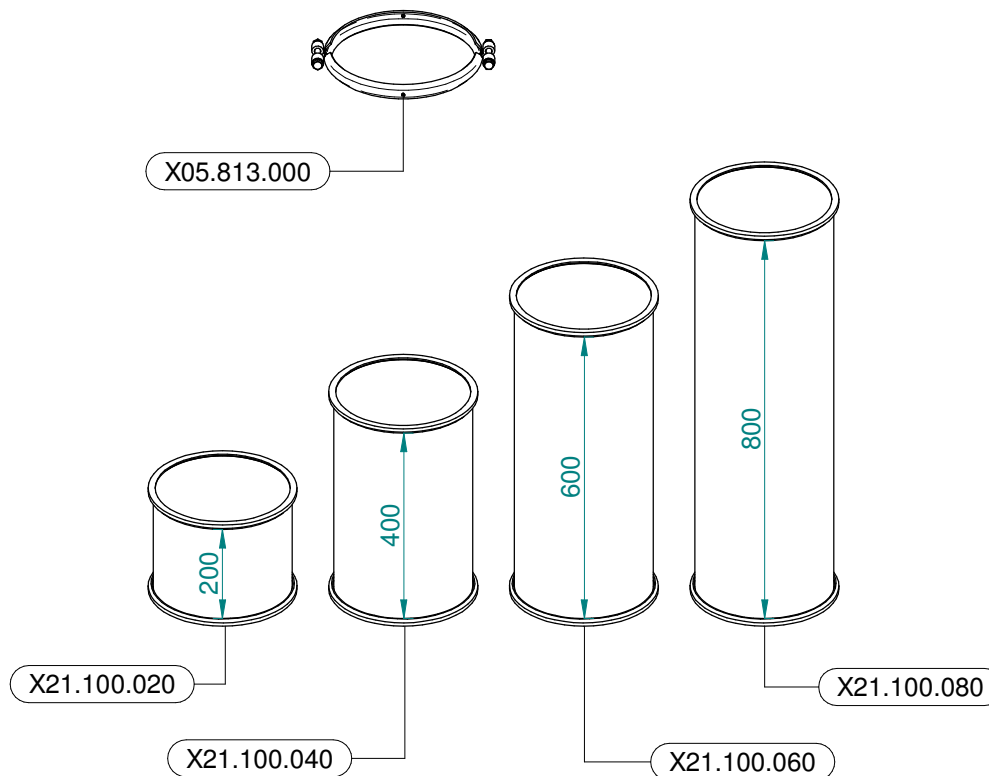

**Ø 250**  
 Plus 55  
 Blitz 55  
 Link 55