

Sez. T25 (⌘)
Movimentazione Elettrica
Electrical Movement

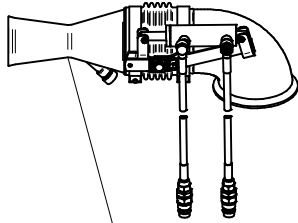
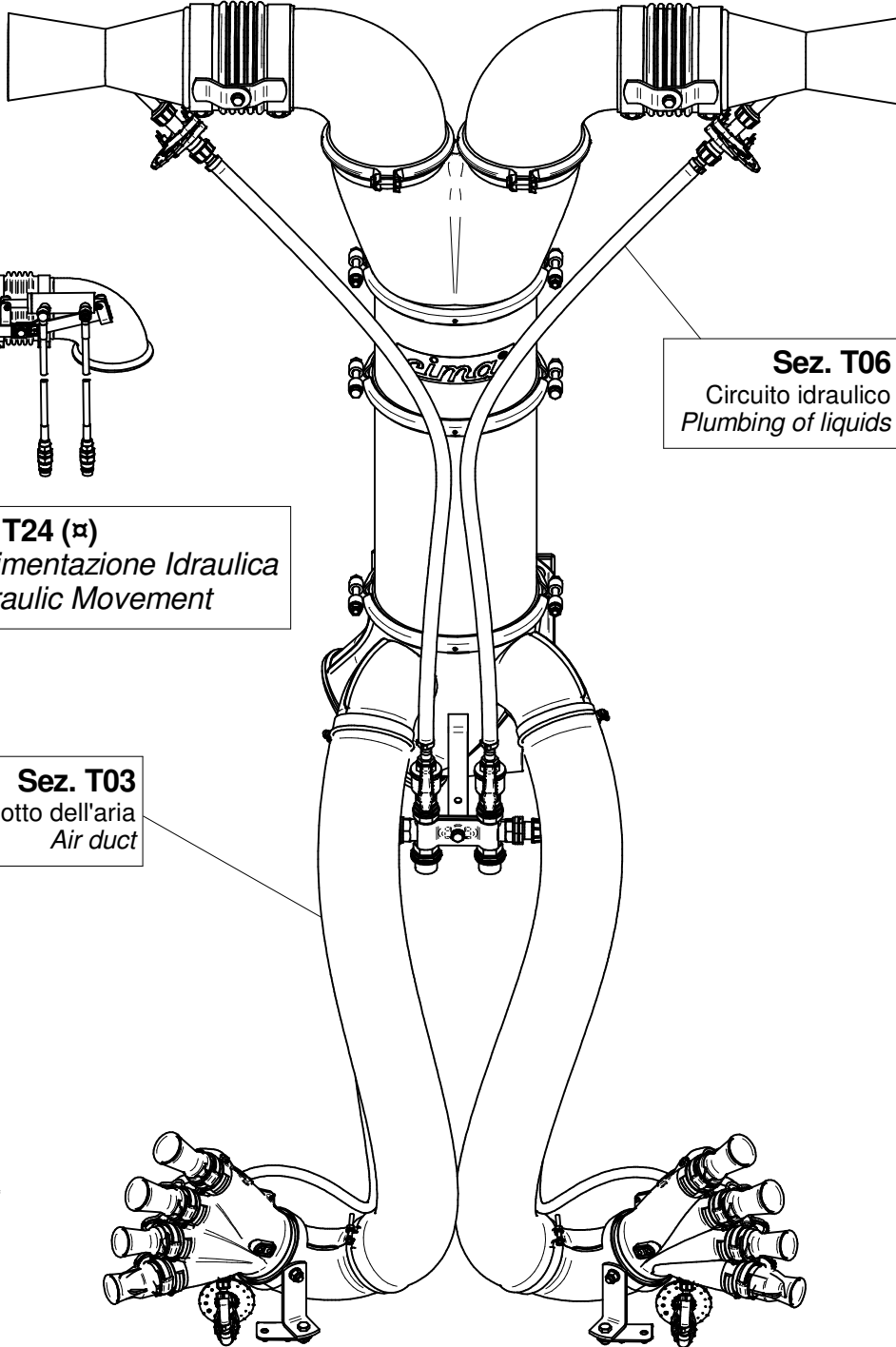
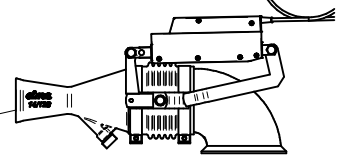

Sez. T24 (⌘)
Movimentazione Idraulica
Hydraulic Movement

Sez. T06
Circuito idraulico
Plumbing of liquids

Sez. T03
Condotto dell'aria
Air duct

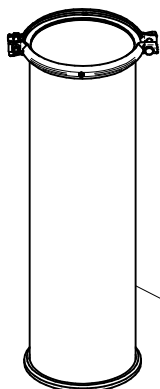

Sez. T28 (⌘)
Prolunghe
Extension

(⌘) A richiesta / Optional Devices

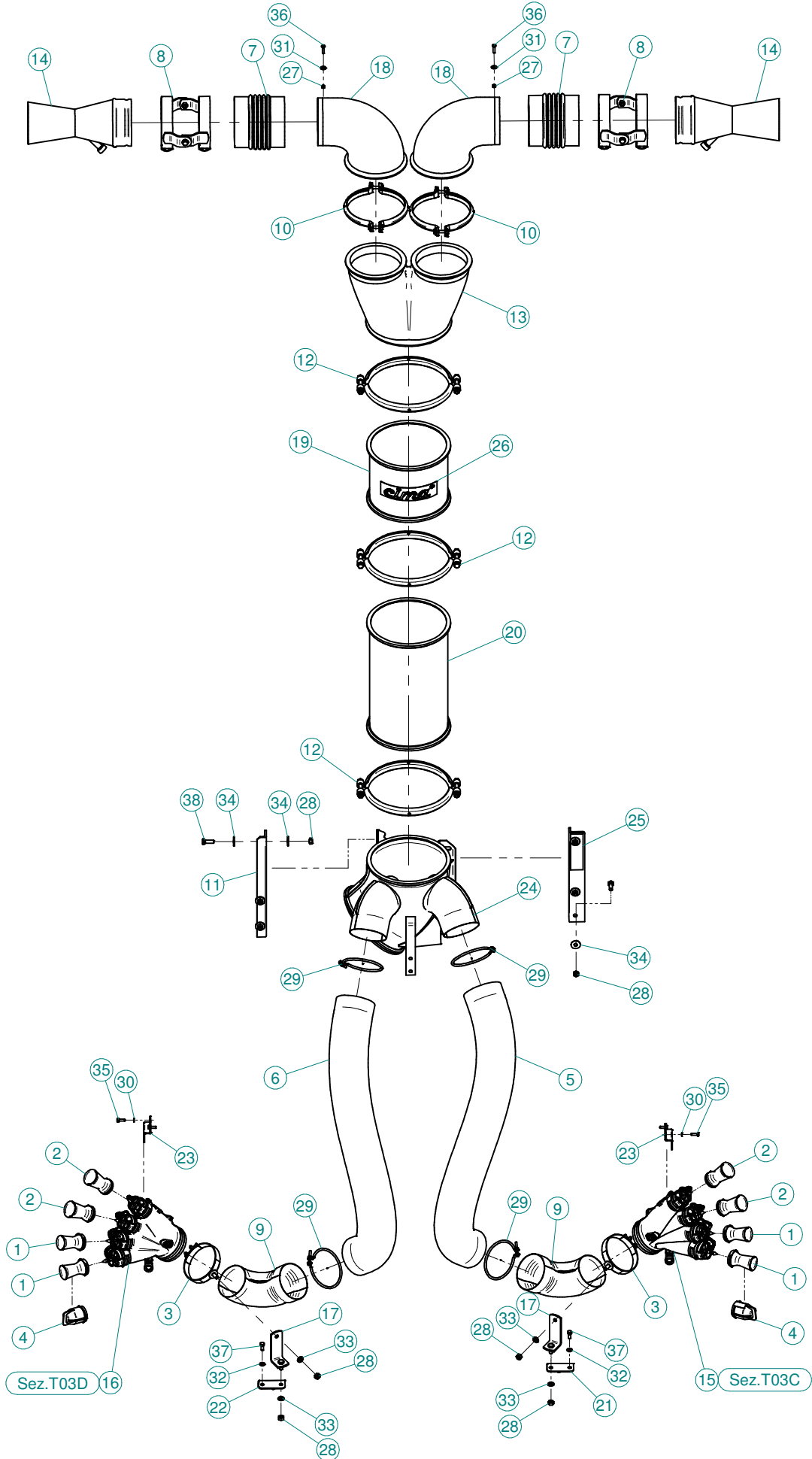

N°	Doc. Number	Titolo	Title	Q.tà
1	X00.006.050	DIFFUSORE 6/50	NOZZLE 6/50	4
2	X00.008.050	DIFFUSORE 8/50	NOZZLE 8/50	4
3	X00.125.001	FEMMINA FASCETTA D.125 ORIENTABILE	FEMALE CLAMP D.125	2
4	X02.127.000	TAPPO DI ATTACCO RAPIDO	CAP NOZZLE PLUG	2
5	X02.239.105	TUBO TANEGUM D.120 L=1050	TANEGUM HOSE D.120 L=1050	1
6	X02.239.105	TUBO TANEGUM D.120 L=1050	TANEGUM HOSE D.120 L=1050	1
7	X02.724.000	MANICOTTO FLESSIBILE D.150 x 160	SLEEVE	2
8	X02.807.000	FASCETTA SNODATA D.150	CLAMP D.150	2
9	X04.845.000	CURVA D.120 A 105°	ELBOW D.120 A 105°	2
10	X05.616.000	COLLARE PER TUBI Ø 175	PIPE CLAMP Ø 175	2
11	X05.809.051	STAFFA FISSAGGIO CURVA A 45°	45° ELBOW BRACKET	1
12	X05.813.000	COLLARE Ø275	CLAMP Ø275	3
13	X05.976.000	CORPO SUP.T.4V T.6V D.250	T.4V T.6V 250D. TOP BODY WITH	1
14	X10.055.150	DIFFUSORE 55/150 CON TUBETTO	NOZZLE 55/150	2
15	X20.014.904CDX	MANO A 4 USCITE COMPLETA DI DISTRIBUTORE	FOUR NOZZLES DIFFUSER	1
16	X20.014.904CSX	MANO A 4 USCITE COMPLETA DI DISTRIBUTORE	FOUR NOZZLES DIFFUSER	1
17	X20.283.000	SQUADRETTA FISSAGGIO MANI	OUTLET'S JOINT PLATE	2
18	X20.558.150	CURVA A 90° D.150	ELBOW 90° D.150	2
19	X21.100.020	PROLUNGA D.250 x 200	EXTENSION D.250 x 200	1
20	X21.100.040	PROLUNGA D.250 x 400	EXTENSION D.250 x 400	1
21	X21.203.001	STAFFETTA DESTRA ATTACCO MANI	BRACKET RIGHT HANDS ATTACK	1
22	X21.204.001	STAFFETTA SINISTRA ATTACCO MANI	BRACKET LEFT HANDS ATTACK	1
23	X40.317.001.A	STAFFA FISSAGGIO DISTRIBUTORE	DISTRIBUTOR FIXING BRACKET	2
24	X50.283.001	CURVA D.250 A 45° CON CORPO A Y D.120	BODY AIR OUTLET	1
25	X50.331.000	STAFFA PER CURVA 45° A CROCERA	ELBOW BRACKET	1
26	X96.118.000	ADESIVO - CIMA 100x200	DECALS - CIMA 100x200	1
27	XD0.06.5588G	DADO M6 6S PG 5588 ZINC.	M6 6S BIG LEAD NUT 5588	2
28	XD0.10.5587G	DADO M10 6S PG 5587 ZINC.	M10 6S BIG LEAD NUT 5587	10
29	XF0.120.000	FASCETTA UNIFILO D.120	CLAMP D.120	4
30	XRP.006.000	RONDELLA PIANA D.6 6592 ZINC.	6mm D. FLAT WASHER	4
31	XRP.006.018	RONDELLA PIANA F.LARGA D.6X18 ZINC.	WASHER Ø 6x18	2
32	XRP.008.000	RONDELLA PIANA D.8 6592 ZINC.	8 D. FLAT WASHER	4
33	XRP.010.000	RONDELLA PIANA D.10 6592 ZINC.	WASHER Ø 10	4
34	XRP.010.030	RONDELLA PIANA F.LARGA D.10X30 ZINC.	10X30mm D. LARGE THREAD FLAT	7
35	XTE.006.020T	VITE TE M6X20 5739 ZINC.	BOLT TE M6X20 5739	4
36	XTE.006.025T	VITE TE UNI 5739-65 M6X25-8.8	SCREW TE UNI 5739-65 M6X25-8.8	2
37	XTE.008.020T	VITE TE UNI 5739-65 M8x20-8.8	SCREW TE UNI 5739-65 M8x20-8.8	4
38	XTE.010.030T	VITE TE UNI 5739-65 M10x30-8.8	SCREW TE UNI 5739-65 M10x30-8.8	6

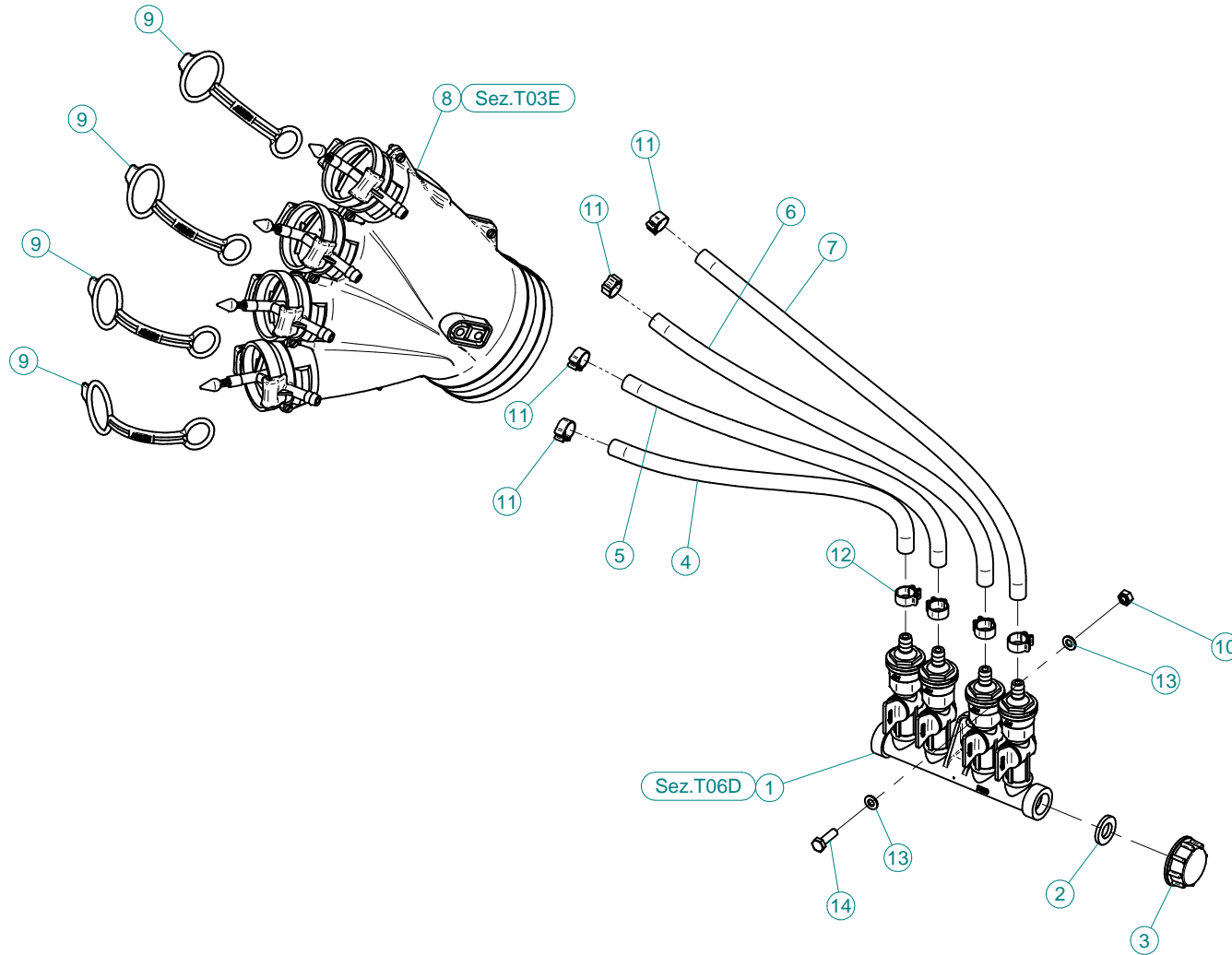

N°	Doc. Number	Titolo	Title	Q.tà
1	X02.008.304C	DISTRIBUTORE LIQUIDI A 4 RUBINETTI CON ANTIGOCCIA	FOUR TAPS LIQUID DISTRIBUTOR WITH ANTI-DRIP DEVICE	1
2	X02.030.010	GUARNIZIONE IN GOMMA D.24X13X3	GASKET D.24X13X3	1
3	X02.182.000	TAPPO 3/4" F.	FEMALE 3/4" CAP	1
4	X02.217.028	TUBO D.8x13 L=280	HOSE D.8x13 L=280	1
5	X02.217.032	TUBO D.8x13 L=320	HOSE D.8x13 L=320	1
6	X02.217.036	TUBO D.8x13 L=360	HOSE D.8x13 L=360	1
7	X02.217.039	TUBO D.8x13 L=390	HOSE D.8x13 L=390	1
8	X20.014.000DX	MANO A 4 USCITE CON TUBETTI	FOUR OUTLETS	1
9	X20.697.000	FERMA DIFFUSORI	NOZZLE STOP	4
10	XD0.06.5588G	DADO M6 6S PG 5588 ZINC.	M6 6S BIG LEAD NUT 5588	2
11	XFC.012,5.014	FASCETTA COBRA SL030705	KOBRA CLAMP SL030705	4
12	XFC.013,5.015	FASCETTA COBRA SL030710	KOBRA CLAMP SL030710	4
13	XRP.006.000	RONDELLA PIANA D.6 6592 ZINC.	6mm D. FLAT WASHER	4
14	XTE.006.020T	VITE TE M6X20 5739 ZINC.	BOLT TE M6X20 5739	2

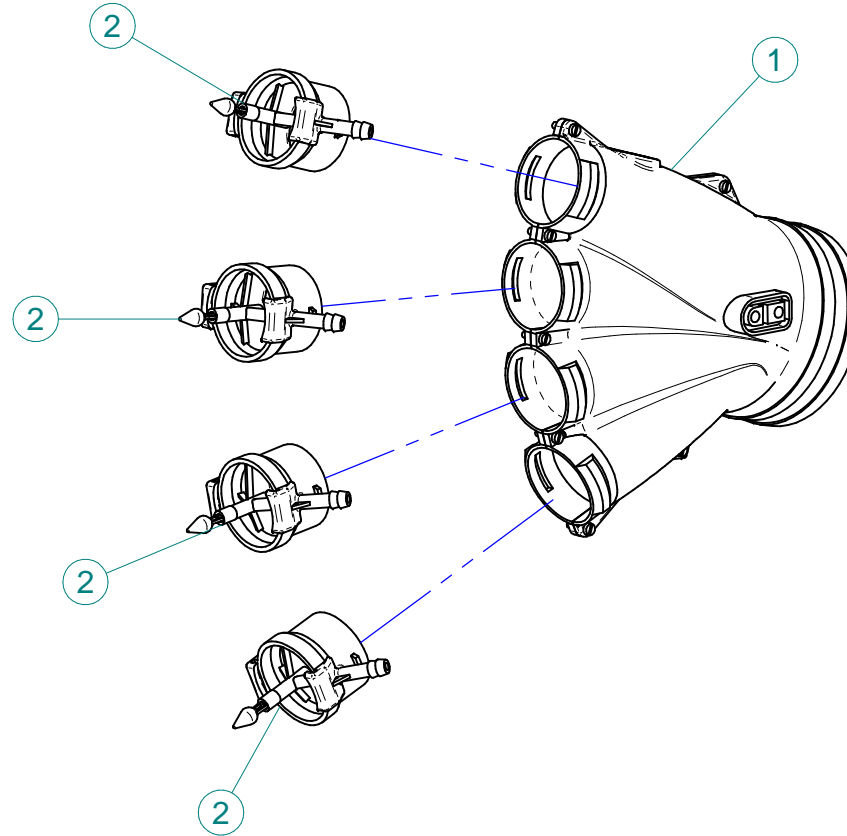

N°	Doc. Number	Titolo	Title	Q.tà
1	X20.014.001DX	MANO A 4 USCITE NUDA	FOUR OUTLETS	1
2	X20.016.01C	RACCORDO ATTACCO RAPIDO PORTA TUBETTO	PIPE WITH OLIVE	4

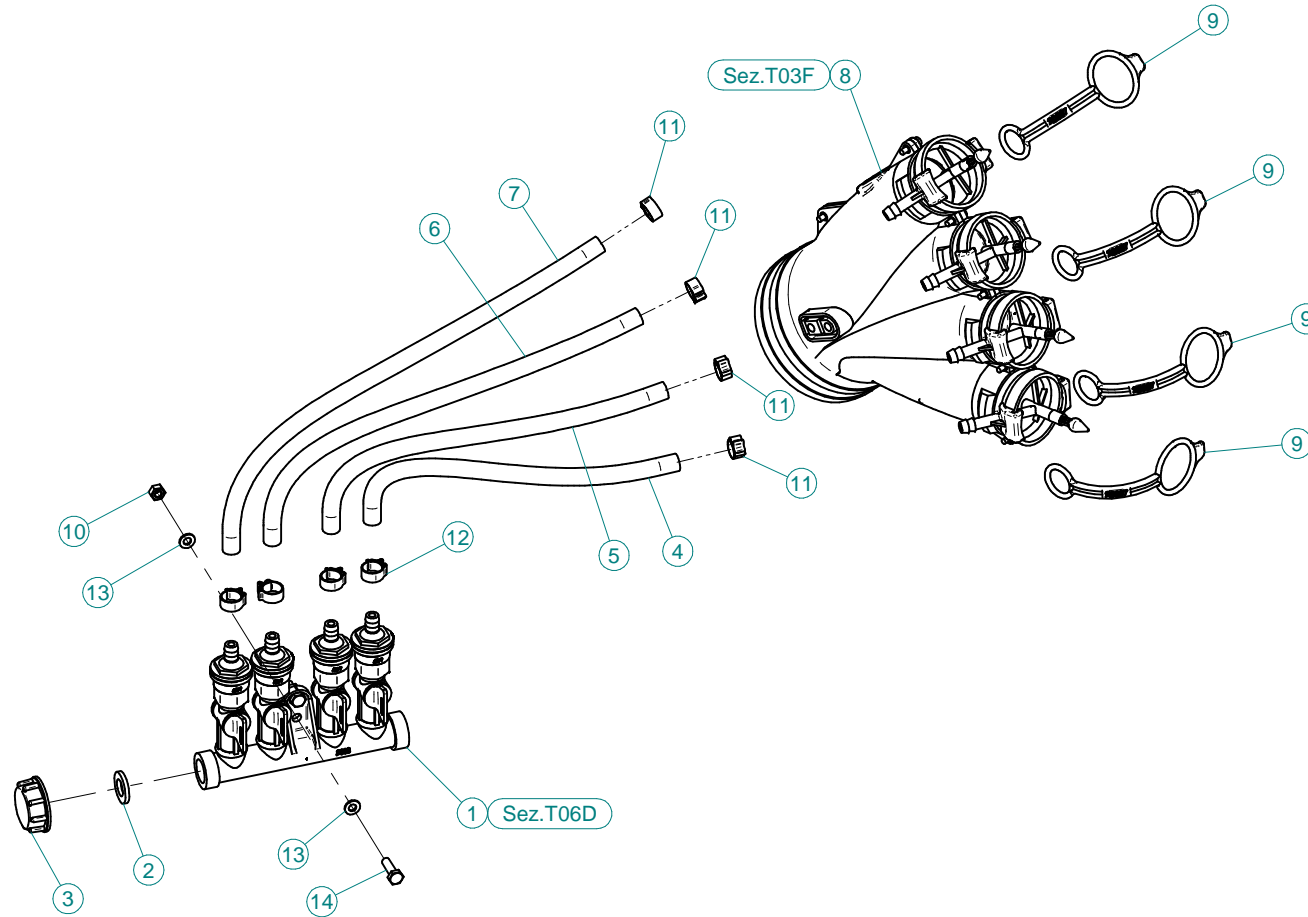

N°	Doc. Number	Titolo	Title	Q.tà
1	X02.008.304C	DISTRIBUTORE LIQUIDI A 4 RUBINETTI CON ANTIGOCCIA	FOUR TAPS LIQUID DISTRIBUTOR WITH ANTI-DRIP DEVICE	1
2	X02.030.010	GUARNIZIONE IN GOMMA D.24X13X3	GASKET D.24X13X3	1
3	X02.182.000	TAPPO 3/4" F.	FEMALE 3/4" CAP	1
4	X02.217.028	TUBO D.8x13 L=280	HOSE D.8x13 L=280	1
5	X02.217.032	TUBO D.8x13 L=320	HOSE D.8x13 L=320	1
6	X02.217.036	TUBO D.8x13 L=360	HOSE D.8x13 L=360	1
7	X02.217.039	TUBO D.8x13 L=390	HOSE D.8x13 L=390	1
8	X20.014.000SX	MANO A 4 USCITE CON TUBETTI	FOUR OUTLETS	1
9	X20.697.000	FERMA DIFFUSORI	NOZZLE STOP	4
10	XD0.06.5588G	DADO M6 6S PG 5588 ZINC.	M6 6S BIG LEAD NUT 5588	2
11	XFC.012,5.014	FASCETTA COBRA SL030705	KOBRA CLAMP SL030705	4
12	XFC.013,5.015	FASCETTA COBRA SL030710	KOBRA CLAMP SL030710	4
13	XRP.006.000	RONDELLA PIANA D.6 6592 ZINC.	6mm D. FLAT WASHER	4
14	XTE.006.020T	VITE TE M6X20 5739 ZINC.	BOLT TE M6X20 5739	2



N°	Doc. Number	Titolo	Title	Q.tà
1	X20.014.001DX	MANO A 4 USCITE NUDA	FOUR OUTLETS	1
2	X20.016.01C	RACCORDO ATTACCO RAPIDO PORTA TUBETTO	PIPE WITH OLIVE	4

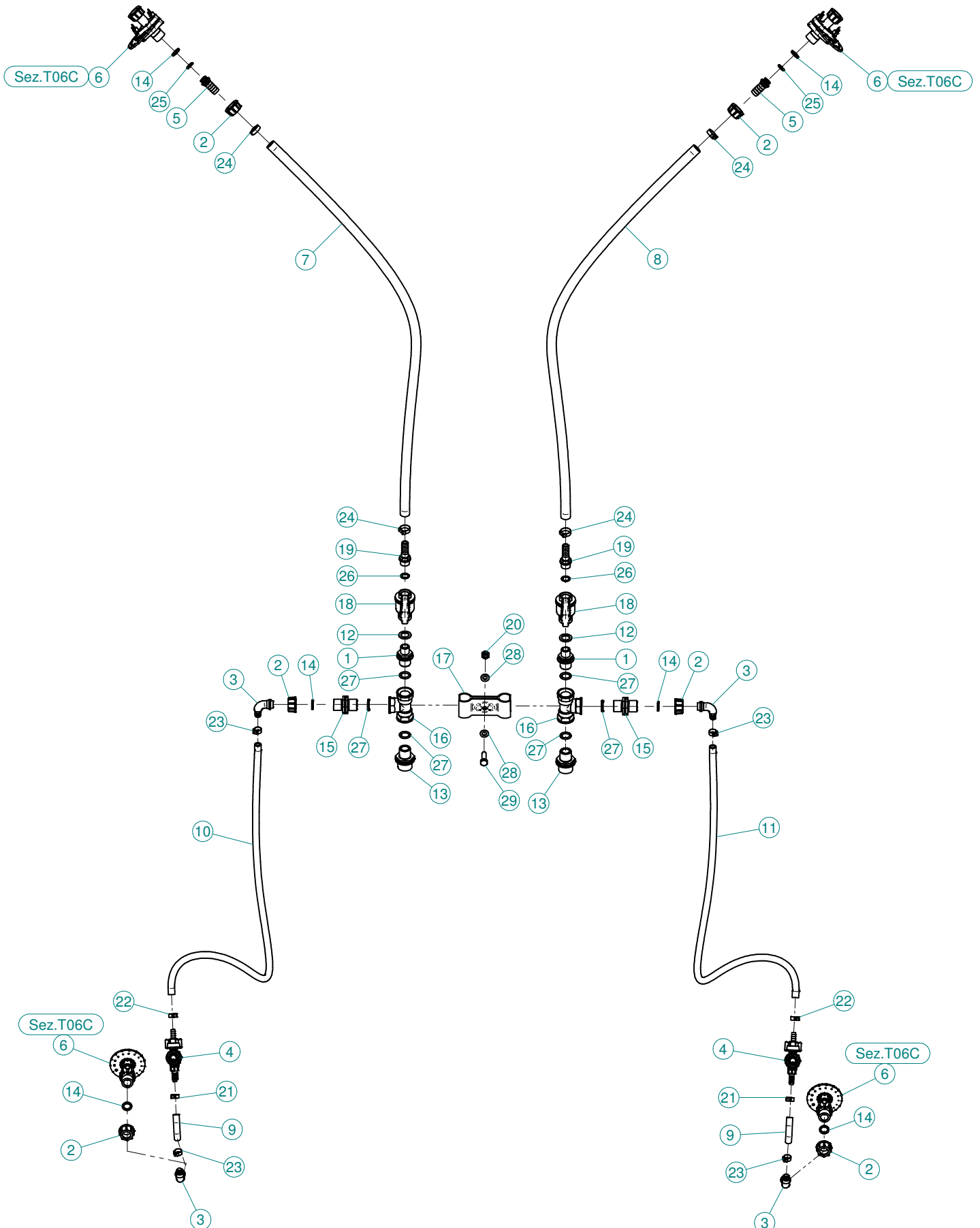

N°	Doc. Number	Titolo	Title	Q.tà
1	X00.055.044	NIPPLO 1/2" GAS 3/4" GAS	NIPPLE 1/2" - 3/4" GAS	2
2	X00.055.045	GIRELLO 3/4" GAS ALTO	3/4" GAS FLY NUT	6
3	X00.055.046R	RACCORDO CURVO P.G. Ø 14	CURVED UNION WITH R.H. D.14	4
4	X00.226.05C	GETTO ANTIGOCCIA DIRITTO COMPLETO (0,3 bar)	COMPLETE ANTIDROP (0,3 bar)	2
5	X02.002.000	RACCORDO DIRITTO 3/4" P.G.16	STRAIGHT UNION 3/4" R.H.16	2
6	X02.150.000	REGOLATORE A DISCO ROTANTE COMPLETO	ROTATION DISK REGULATION	4
7	X02.211.130	TUBO Ø16x23 L=1300	HOSE Ø16x23 L=1300	1
8	X02.211.130	TUBO Ø16x23 L=1300	HOSE Ø16x23 L=1300	1
9	X02.213.007	TUBO Ø10x16 L=70	HOSE Ø10x16 L=70	2
10	X02.213.115	TUBO Ø10x16 L=1150	HOSE Ø10x16 L=1150	1
11	X02.213.115	TUBO Ø10x16 L=1150	HOSE Ø10x16 L=1150	1
12	X02.265.000	GUARNIZIONE PIANA Ø 20/30 x 2,5	PLANE GASKET Ø 20/30 X 2,5	2
13	X02.293.000	RIDUZIONE 1" M - 3/4" M	1" M - 3/4" M REDUCER NIPPLE	2
14	X02.349.000	GUARNIZIONE PIANA D.17X23X3	17X23X3 FLAT GASKET (G4000B)	6
15	X02.380.000	NIPPLO 3/4"	NIPPLE 3/4"	2
16	X02.396.000	RACCORDO A T 3/4" - 3/4" - 3/4" F.	UNION 3/4" - 3/4" - 3/4" F.	2
17	X02.999.000	STAFFA FISSAGGIO RACCORDO A T	T UNION FIXING BRACKET	1
18	X21.147.000	VALVOLA A SFERA 1/2" F/F	WAYS VALVE 1/2" F/F	2
19	X21.151.000	RACCORDO DIRITTO PG D. 16	STRAIGHT HOSE R.H. D. 16	2
20	XDA.010.0BG	DADO AUTOBLOCCANTE M10	SELF LOCKING NUT M10	1
21	XFC.013,5.015	FASCETTA COBRA SL030710	KOBRA CLAMP SL030710	2
22	XFC.015,5.017	FASCETTA COBRA SLO30720	KOBRA CLAMP	2
23	XFC.016,5.018	FASCETTA COBRA 16,5 - 18	KOBRA CLAMP 16,5 - 18	4
24	XFC.022,5.024	FASCETTA COBRA SLO30756	KOBRA CLAMP SLO30756	4
25	XOR.000.117	OR D.13,1X2,62	13.1X2.62 O-RING GASKET	2
26	XOR.000.121	OR D. 15,88 x 2,62	15,88 x 2,62 O-RING GASKET	2
27	XOR.004.081	OR Ø 20,22 x 3,53	20,22 x 3,53 O-RING GASKET	6
28	XRP.010.000	RONDELLA PIANA D.10 6592 ZINC.	WASHER Ø 10	2
29	XTE.010.035T	VITE TE UNI 5739-65 M10x35-8.8	SCREW TE UNI 5739-65 M10x35-8.8	1



N°	Doc. Number	Titolo	Title	Q.tà
1	X02.147.500	COPPIA DI SEMICORPO REGOLATORE	REGULATOR HALF-BODY	1
2	X02.148.000	DISCO ROTANTE PER REGOLATORE	REGULATOR DISK	1
3	X02.349.000	GUARNIZIONE PIANA D.17X23X3	17X23X3 FLAT GASKET (G4000B)	1
4	XDF.OTT.006	DADO AD ALETTE IN OTTONE M6	BRASS M6 WING NUT	2
5	XOR.002.062	OR D.15,6X1,78	15.6X1.78 O-RING GASKET	2
6	XRP.006.001	RONDELLA PIANA D.6 INOX	WASHER D.6	2
7	XTE.006.030I	VITE TE M6X30 INOX 5739	BOLT TE M6X30 STAINLESS STEEL 5739	2



N°	Doc. Number	Titolo	Title	Q.tà
1	X00.227.01C	DISPOSITIVO ANTIGOCCIA	ANTI DRIP DEVICE	4
2	X02.008.000	DISTRIBUTORE LIQUIDO TESTATE	SPRAYHEADS LIQUID DISTRIBUTOR	1
3	X20.202.100	RUBINETTO F.1/4" M.18X1,5	TAP ASSEMBLY	4
4	XOR.000.117	OR D.13,1X2,62	13.1X2.62 O-RING GASKET	4

Gli esplosi elencati di seguito sono relativi
a varianti o accessori a richiesta

The exploded drawings listed below are related
to different versions or optional accessories

Le vues éclatées suivantes sont relatives
à des variantes ou à des accessoires optionnels

Dibujos de vista despiezada son relativos a
variantes o accesorios opcionales

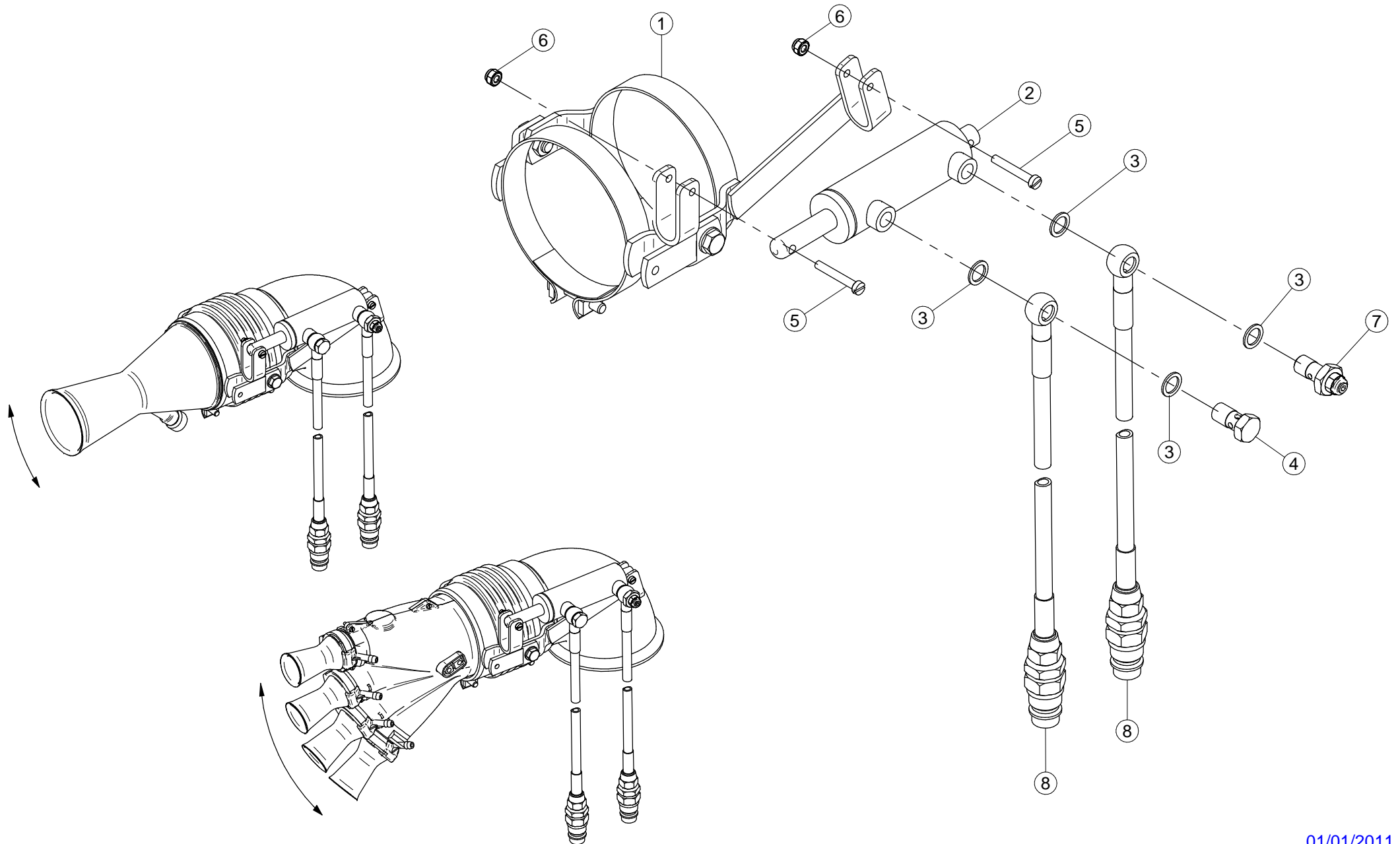

N°	Doc. Number	Titolo	Title	Q.tà	Note
1	X02.140.200	COPPIA FASCETTE ORIENTABILI D.127 CON ATTACCO PISTONE	CLAMP D.127 WITH JACK BRACKET	2	
2	X02.840.04C	MARTINETTO COMPLETO D.20/30 CORSA 60	JACK	2	
3	X02.472.000	RONDELLA DI RAME	COPPER WASHER	8	
4	X02.408.000	RACCORDO DRITTO PER OCCHIO	JACK EYE RIGHT UNION	2	
5	XTC.06.40.07I	VITE T.CIL. M6 x 40 INOX	INOX SCREW M6 x 40	4	
6	XDA.006.0AG	DADO AUTOBLOCCANTE M6 ALTO PG	SELF-LOCKING NUT - HIGH M6	4	
7	X20.718.000	REGOLATORE PORTATA IDRAULICA	FLOW REGULATOR	2	
8	X20.900.680	TUBO OLIO PER MARTINETTO L=6800	OIL PIPE FOR JACK L=6800	4	

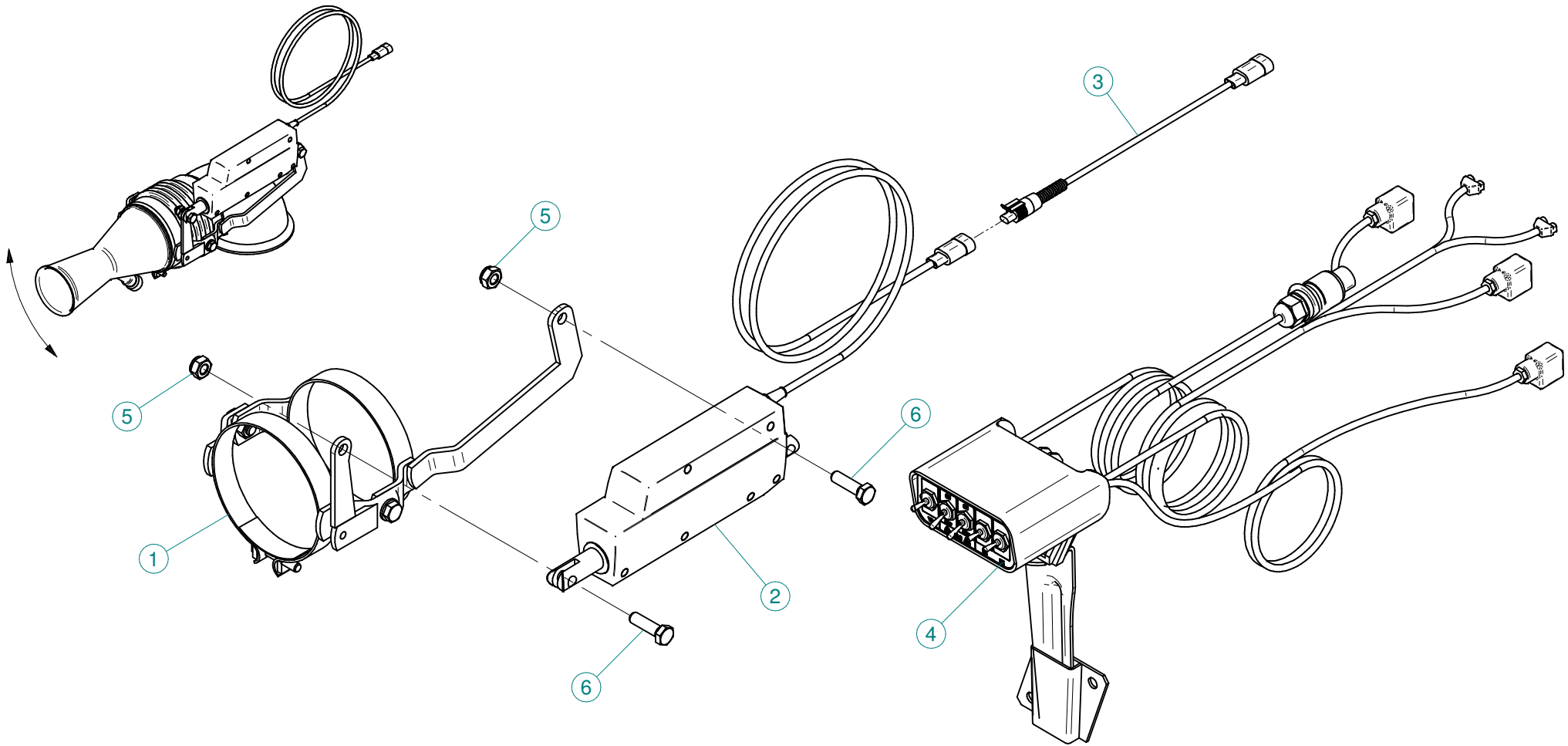

N°	Doc. Number	Titolo	Title	Q.tà
1	X02.140.500	COPPIA FASCETTE ORIENTABILI D.127 CON ATTACCO ATTUATORE	CLAMP D.127 WITH ACTUATOR BRACKET	2
2	X21.016.000	ATTUATORE LINEARE (LA 12.1)	LINEAR ACTUATOR (LA 12.1)	2
3	X21.474.000	CAVO L=2000 mm COLLEGAMENTO ATTUATORI ELETTRICI	CABLE L=2000 mm ACTUATORS CONNECTION	2
4	X21.530.200	KIT COMANDO ELETTRICO PER PLUS LINK	CONTROL BOX ASSEMBLY FOR PLUS - LINK	1
5	XDA.010.0BG	DADO AUTOBLOCCANTE M10	SELF LOCKING NUT M10	4
6	XTE.010.035T	VITE TE UNI 5739-65 M10x35-8.8	SCREW TE UNI 5739-65 M10x35-8.8	4

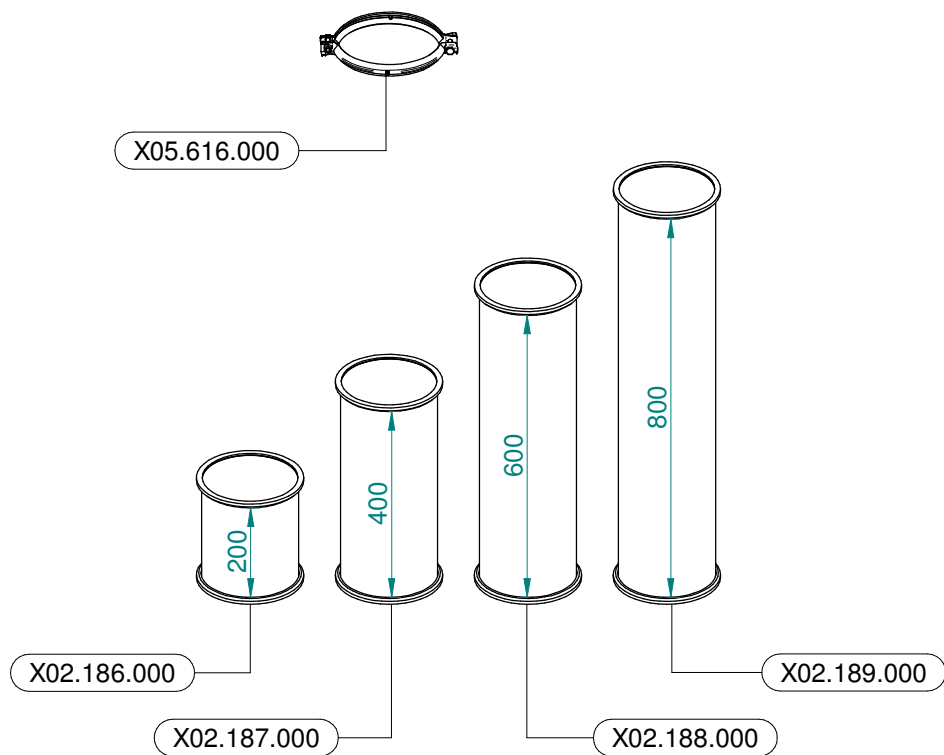

Ø 175
 Plus 42 - 45 - 50
 Blitz 45 - 50
 Link 50

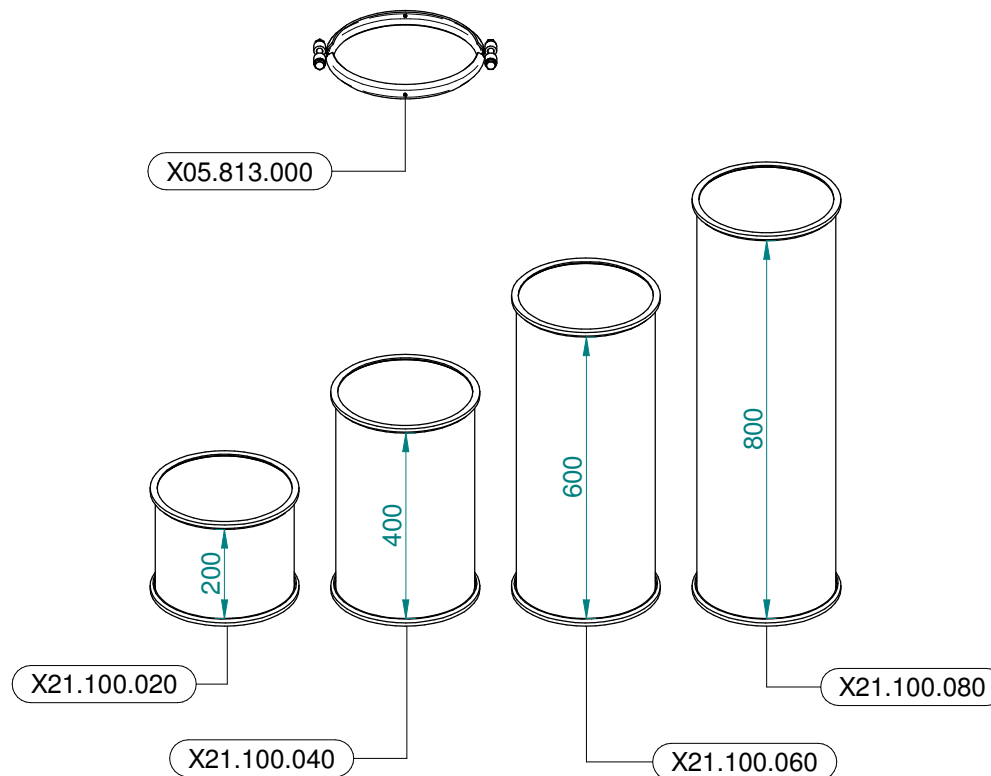

Ø 250
 Plus 55
 Blitz 55
 Link 55