

N°	Doc. Number	Titolo	Title	Q.tà
1	X04.785.000	MOLLA A COMPRESSIONE	SPRING	2
2	X20.182.0DX	SUPPORTO DI SOSTEGNO BRACCIO DX	RH SUPPORTING RIGHT	1
3	X20.182.0SX	SUPPORTO DI SOSTEGNO BRACCIO SX	LH SUPPORTING LEFT	1
4	X20.184.001	TELAIO CENTRALE BPN 5-7 m	CENTRAL FRAME	1
5	X20.185.000DX	BRACCIO LATERALE DESTRO	SIDE SECTION RIGHT FOR BOOM	1
6	X20.185.000SX	BRACCIO LATERALE DESTRO	SIDE SECTION LEFT FOR BOOM	1
7	X20.187.000.Z	PROLUNGA PER BRACCIO LATERALE	EXTENSION FOR SIDE SECTION	2
8	X20.188.000	PERNO DI ROTAZIONE PER BRACCI LATERALI	SPECIAL BOLT	2
9	X20.189.000.Z	SUPPORTO PER DIFFUSORI CENTRALI	CENTRAL SUPPORT FOR 2 OUTLETS	1
10	X20.225.000	PIATTO SAGOMATO FISS. SUPP. BRACCIO	SHAPED PLATE FIXING SUPPORTING JOINT	4
11	X20.230.000	TUBO DISTANZIALE	DISTANCE PIPE	2
12	X21.006.000	STAFFA	STIRRUP	2
13	XBRF.010.021	BARRA FILETTATA M10	THREADED BAR M10	2
14	XD0.10.5587G	DADO M10 6S PG 5587 ZINC.	M10 6S BIG LEAD NUT 5587	18
15	XD0.12.5587G	DADO M12 PG UNI 5587	M12 NUT	4
16	XD0.20.5587G	DADO M20	NUT M20	6
17	XDA.010.0BG	DADO AUTOBLOCCANTE M10	SELF LOCKING NUT M10	4
18	XID.006.001	INGRASSATORE DIRITTO M6	GREASER	2
19	XRP.010.000	RONDELLA PIANA D.10 6592 ZINC.	WASHER Ø 10	17
20	XRP.010.030	RONDELLA PIANA F.LARGA D.10X30 ZINC.	10X30mm D. LARGE THREAD FLAT	14
21	XRP.012.000	RONDELLA PIANA Ø12	WASHER Ø12	4
22	XRP.020.000	RONDELLA PIANA D.20	WASHER D.20	6
23	XS0.454.000	ANELLO PASSATUBI D.10	KEEPING HOSE RING	2
24	XS0.454.100	ANELLO PASSATUBI D.10	KEEPING HOSE RING	2
25	XS0.457.000	MOLLA D.33.5 L=110 FIL. D.4.5	SPRING D.33.5 L=110 FIL. D.4.5	2
26	XTE.010.035T	VITE TE UNI 5739-65 M10x35-8.8	SCREW TE UNI 5739-65 M10x35-8.8	2
27	XTE.010.050T	VITE TE M10X50 5739 ZINC.	BOLT TE M10X50 5739	8
28	XTE.010.060T	VITE TE UNI 5739-65 M10x60-8.8	SCREW TE UNI 5739-65 M10x60-8.8	2
29	XTE.010.070T	VITE TE UNI 5739-65 M10x70-8.8	SCREW TE UNI 5739-65 M10x70-8.8	4

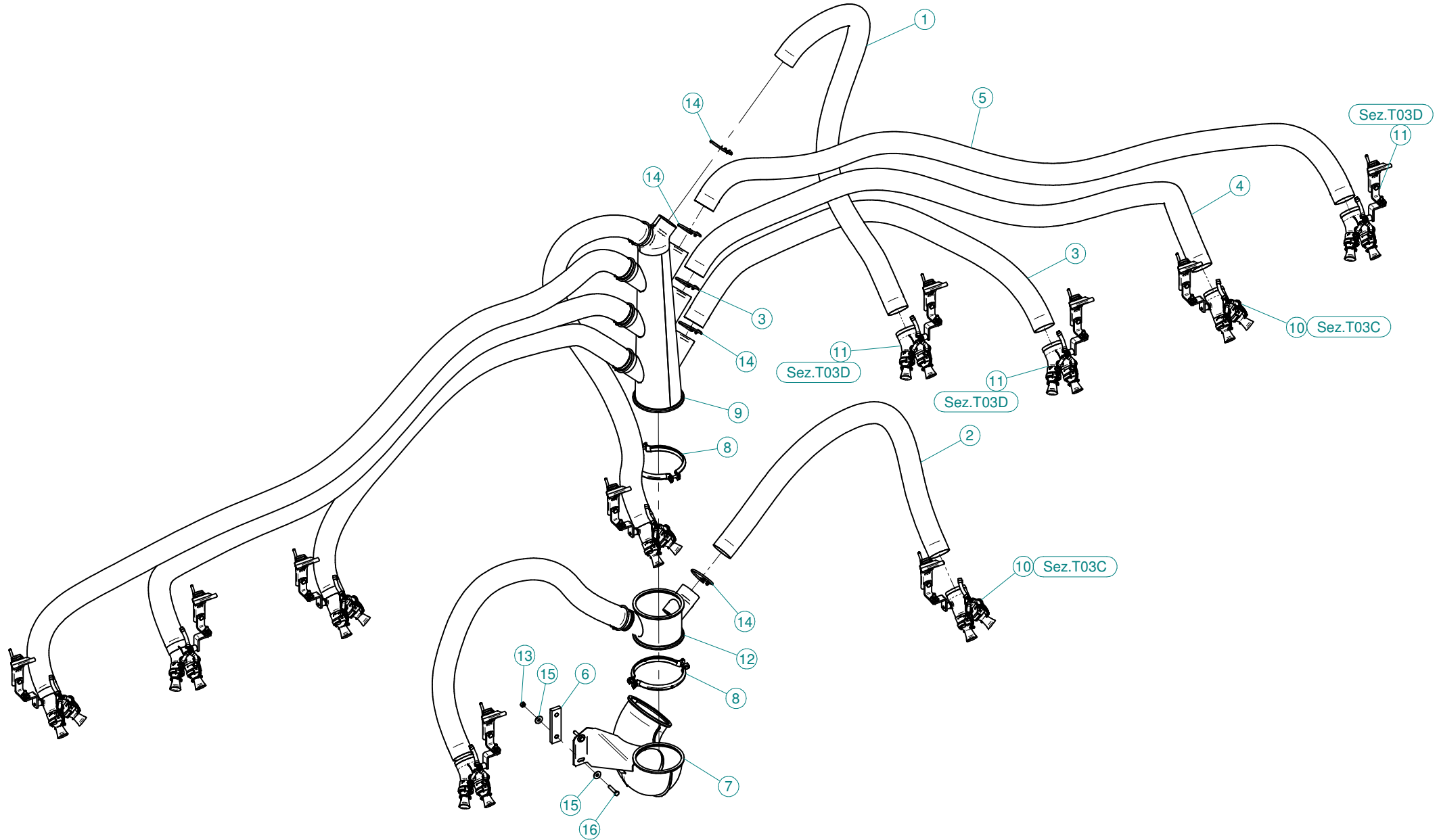

N°	Doc. Number	Titolo	Title	Q.tà
1	X02.280.170	TUBO SPIRALATO Ø80 L=1700	HOSE Ø80 L=1700	2
2	X02.280.220	TUBO SPIRALATO Ø80 L=2200	HOSE Ø80 L=2200	2
3	X02.280.270	TUBO SPIRALATO Ø80 L=2700	HOSE Ø80 L=2700	2
4	X02.280.300	TUBO SPIRALATO Ø80 L=3000	HOSE Ø80 L=3000	2
5	X02.280.420	TUBO SPIRALATO Ø80 L=4200	HOSE Ø80 L=4200	2
6	X02.992.000	STAFFA FISSAGGIO CURVE	BRACKET	1
7	X04.882.000	CURVA INFERIORE D. 175 PER PORTATI	LOWER BEND D. 175	1
8	X05.616.000	COLLARE PER TUBI Ø 175	PIPE CLAMP Ø 175	2
9	X20.183.001	CORPO CENTRALE A 8 USCITE D.80 PER BARRE	BODY WITH 8 OUTLETS D.80 FOR BARS	1
10	X20.221.02CDX	MANO 2 USCITE DX COMPLETA DI STAFFA	COMPLETE 2 NOZZLES RIGHT BODY KIT	5
11	X20.221.02CSX	MANO 2 USCITE Sx COMPLETA DI STAFFA	COMPLETE 2 NOZZLES LEFT BODY KIT	5
12	X20.470.000	TRONCHETTO D.175 CON 2 USCITE D.80	BODY D.175 WITH 2 OUTLETS D.80	1
13	XD0.10.5587G	DADO M10 6S PG 5587 ZINC.	M10 6S BIG LEAD NUT 5587	2
14	XF0.080.000	FASCETTA UNIFILO D.80	CLAMP D.80	10
15	XRP.010.030	RONDELLA PIANA F.LARGA D.10X30 ZINC.	10X30mm D. LARGE THREAD FLAT	4
16	XTE.010.050T	VITE TE M10X50 5739 ZINC.	BOLT TE M10X50 5739	2

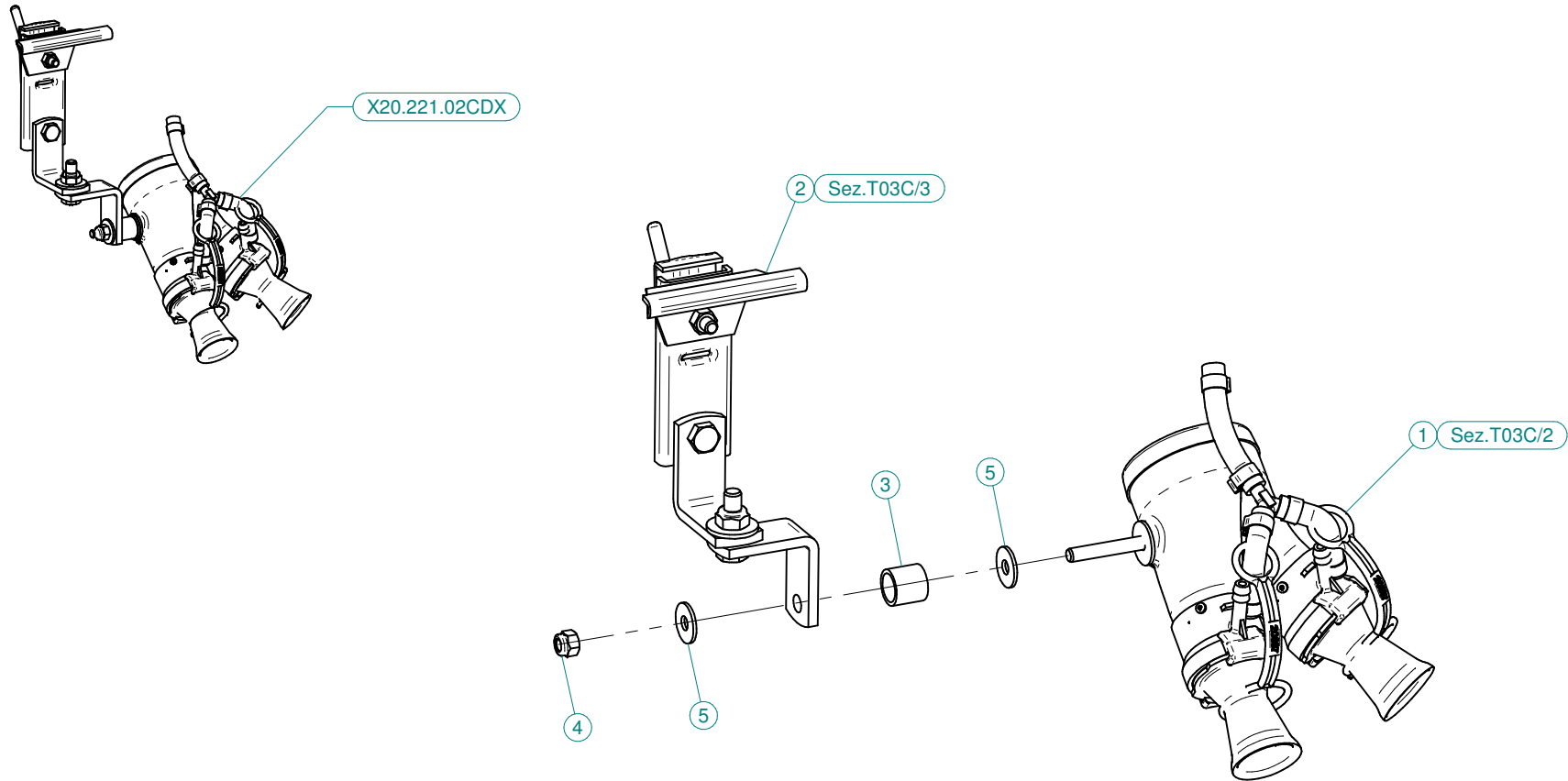

N°	Doc. Number	Titolo	Title	Q.tà
1	X02.221.101CDX	MANO 2 USCITE DX COMPLETA DI DIFFUSORI	2 NOZZLES RIGHT BODY KIT	1
2	X20.067.10CDX	SUPPORTO SCORREVOLE PORTA MANO	SLIDING HAND SUPPORT	1
3	X20.265.000	DISTANZIALE	SPACER	1
4	XDA.008.0AG	DADO AUTOBLOCCANTE M8 ALTO PG ZINC.	HIGH BIG LEAD M8 SELFLOCKING	1
5	XRP.008.024	RONDELLA PIANA F.LARGA D.8X24 ZINC.	WASHER D.8X24	2

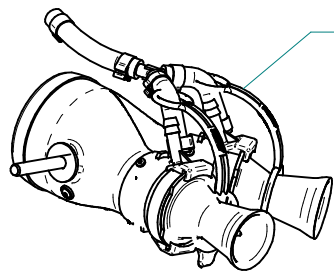

X20.221.101CDX

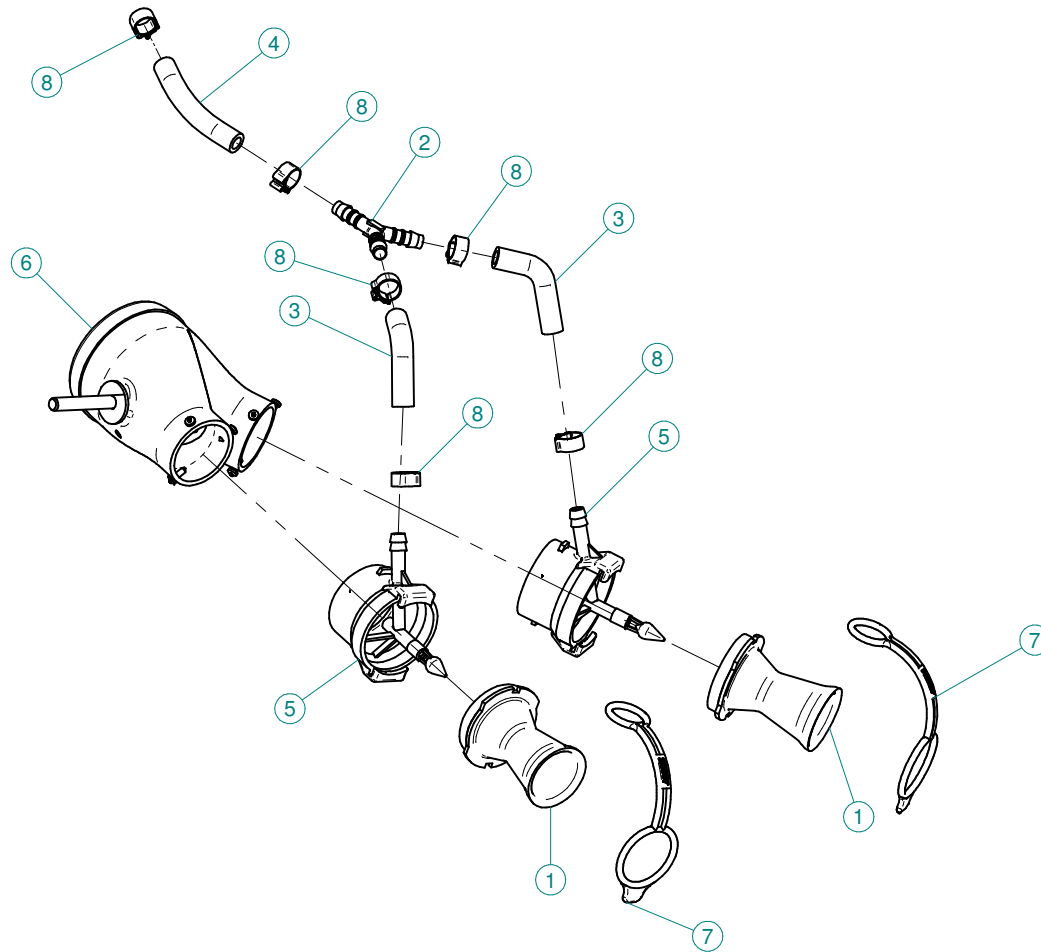

N°	Doc. Number	Titolo	Title	Q.tà
1	X00.003,5.50	DIFFUSORE 3,5/50	NOZZLE 3,5/50	2
2	X02.077.010	RACCORDO A Y D.8-8-8	Y FITTING	1
3	X02.217.005	TUBO Ø8x13 L=50	HOSE Ø8x13 L=50	2
4	X02.217.009	TUBO Ø8x13 L=90	HOSE Ø8x13 L=90	1
5	X20.016.01C	RACCORDO ATTACCO RAPIDO PORTA TUBETTO	PIPE WITH OLIVE	2
6	X20.221.500DX	MANO 2 USCITE DX	RH 2 OUTLETS	1
7	X20.697.000	FERMA DIFFUSORI	NOZZLE STOP	2
8	XFC.012,5.014	FASCETTA COBRA SL030705	KOBRA CLAMP SL030705	6

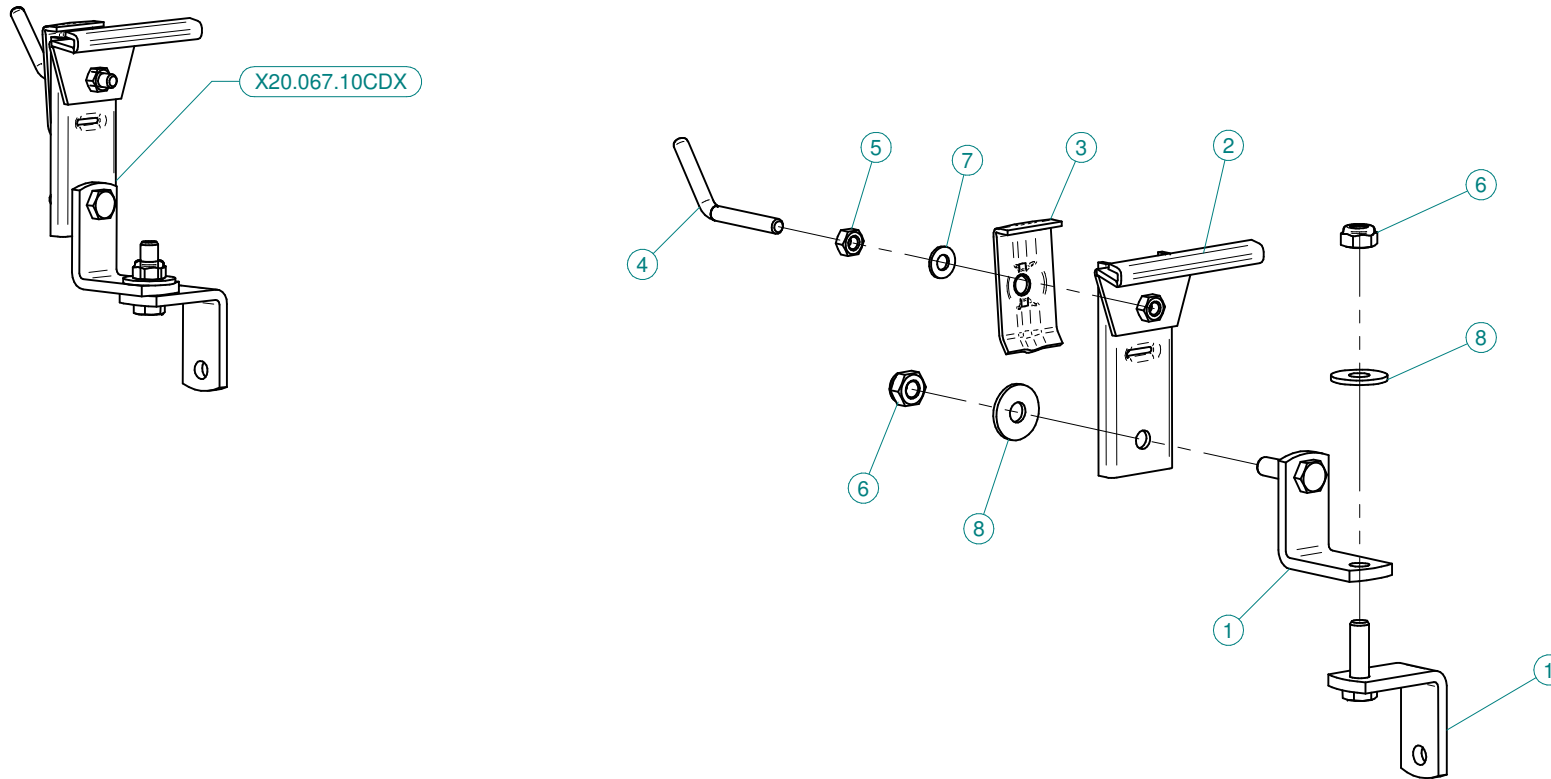

N°	Doc. Number	Titolo	Title	Q.tà
1	X04.787.000	SQUADRETTA PER DIFFUSORI BARRE	BRACKET FOR BARS	2
2	X20.067.010	SUPPORTO SCORREVOLE PER MANO A 2 DIFFUSORI	SLIDING SUPPORT FOR A HAND 2 DIFFUSERS	1
3	X20.068.000	STAFFA FISSAGGIO SCORREVOLE PER BARRA	BRACKET	1
4	X20.069.000	MANIGLIA DI BLOCCAGGIO M8	M8 FIXING LEVER	1
5	XD0.08.5587G	DADO M8 PG 5587	NUT M8	1
6	XDA.010.0BG	DADO AUTOBLOCCANTE M10	SELF LOCKING NUT M10	2
7	XRP.008.000	RONDELLA PIANA D.8 6592 ZINC.	8 D. FLAT WASHER	1
8	XRP.010.030	RONDELLA PIANA F.LARGA D.10X30 ZINC.	10X30mm D. LARGE THREAD FLAT	2

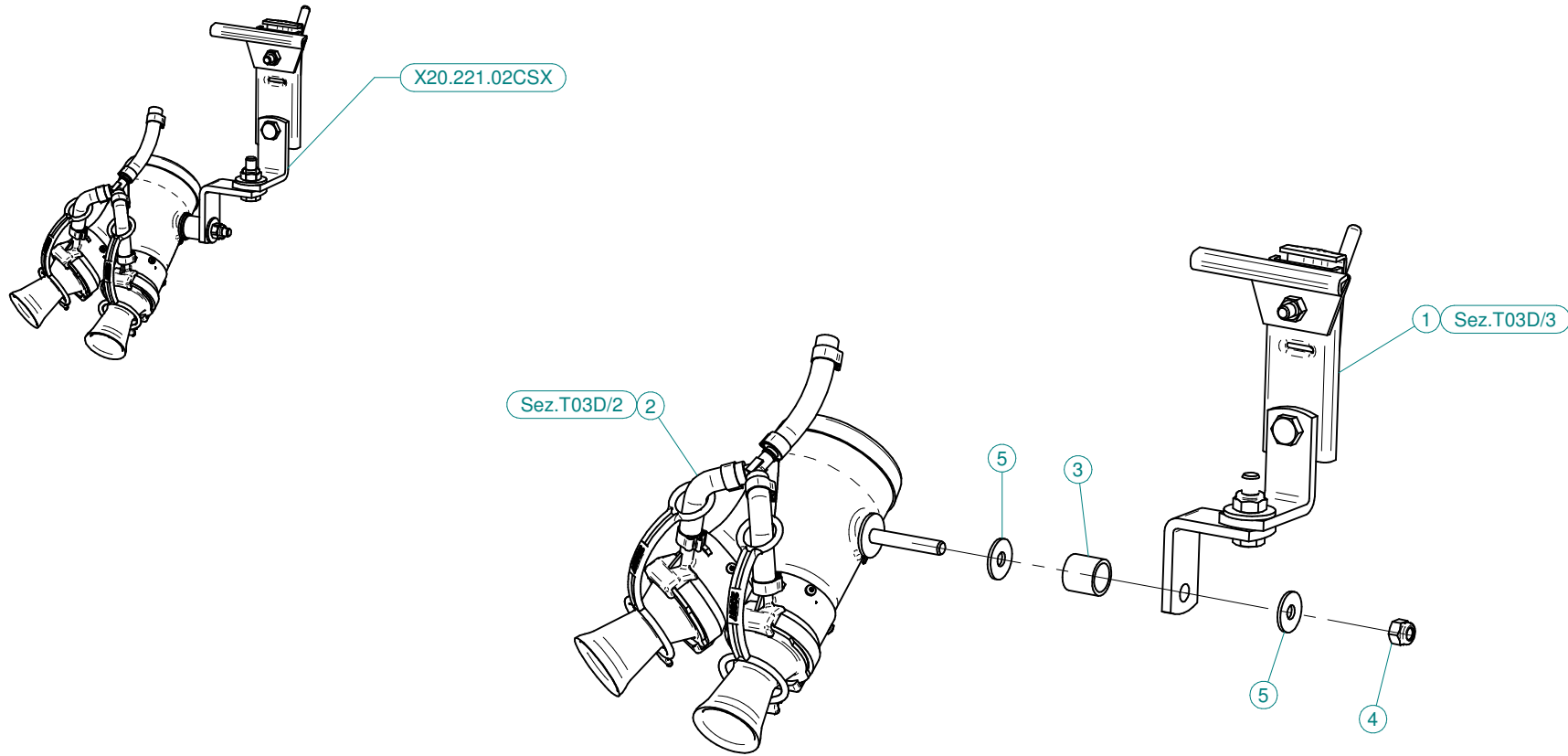

N°	Doc. Number	Titolo	Title	Q.tà
1	X20.067.10CSX	SUPPORTO SCORREVOLE PORTA MANO	SLIDING HAND SUPPORT	1
2	X20.221.101CSX	MANO 2 USCITE SX COMPLETA DI DIFFUSORI	2 NOZZLES LEFT BODY KIT	1
3	X20.265.000	DISTANZIALE	SPACER	1
4	XDA.008.0AG	DADO AUTOBLOCCANTE M8 ALTO PG ZINC.	HIGH BIG LEAD M8 SELFLOCKING	1
5	XRP.008.024	RONDELLA PIANA F.LARGA D.8X24 ZINC.	WASHER D.8X24	2

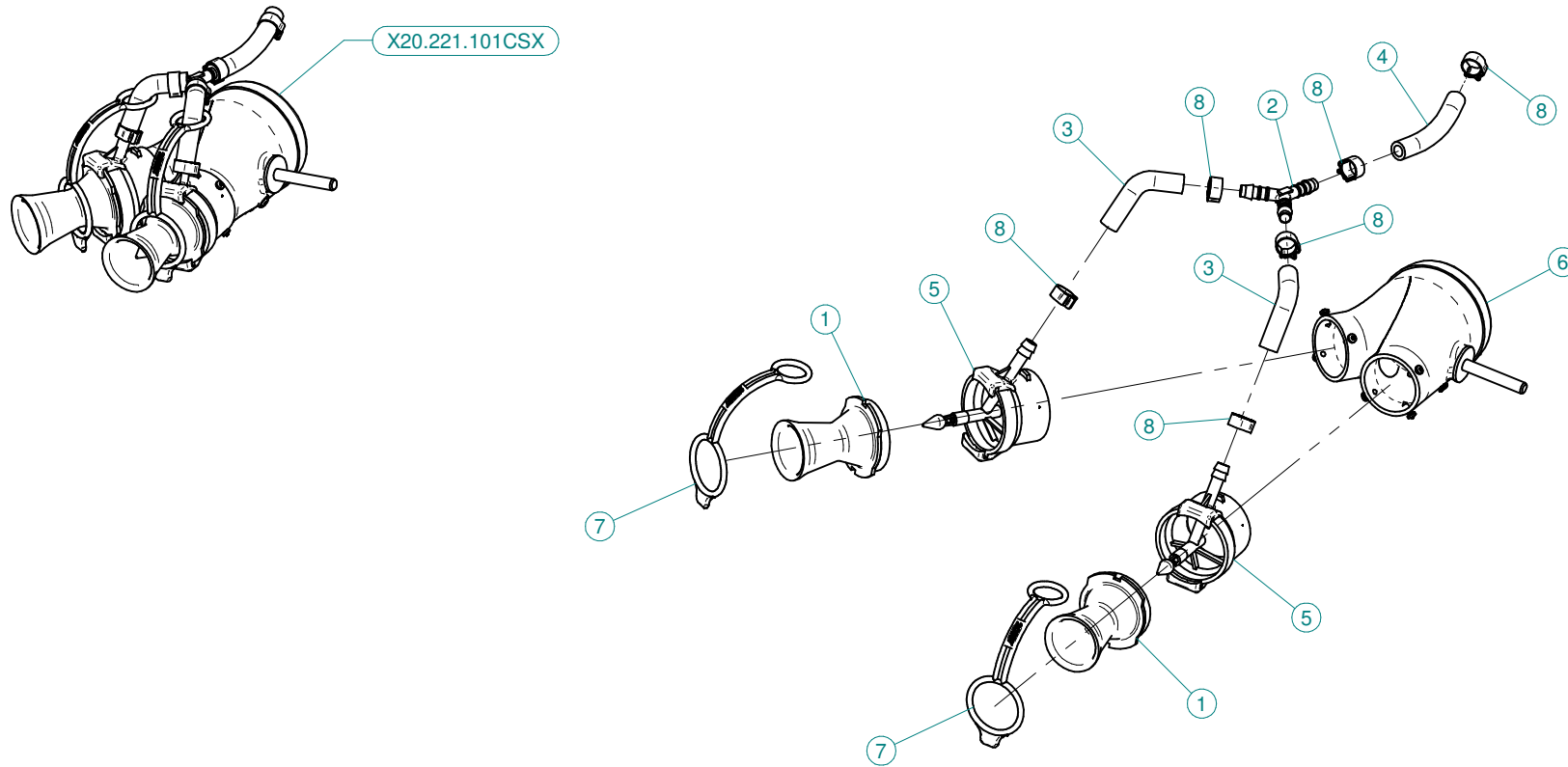

N°	Doc. Number	Titolo	Title	Q.tà
1	X00.003,5.50	DIFFUSORE 3,5/50	NOZZLE 3,5/50	2
2	X02.077.010	RACCORDO A Y D.8-8-8	Y FITTING	1
3	X02.217.005	TUBO Ø8x13 L=50	HOSE Ø8x13 L=50	2
4	X02.217.009	TUBO Ø8x13 L=90	HOSE Ø8x13 L=90	1
5	X20.016.01C	RACCORDO ATTACCO RAPIDO PORTA TUBETTO	PIPE WITH OLIVE	2
6	X20.221.500SX	MANO 2 USCITE SX	LH 2 OUTLETS	1
7	X20.697.000	FERMA DIFFUSORI	NOZZLE STOP	2
8	XFC.012,5.014	FASCETTA COBRA SL030705	KOBRA CLAMP SL030705	6

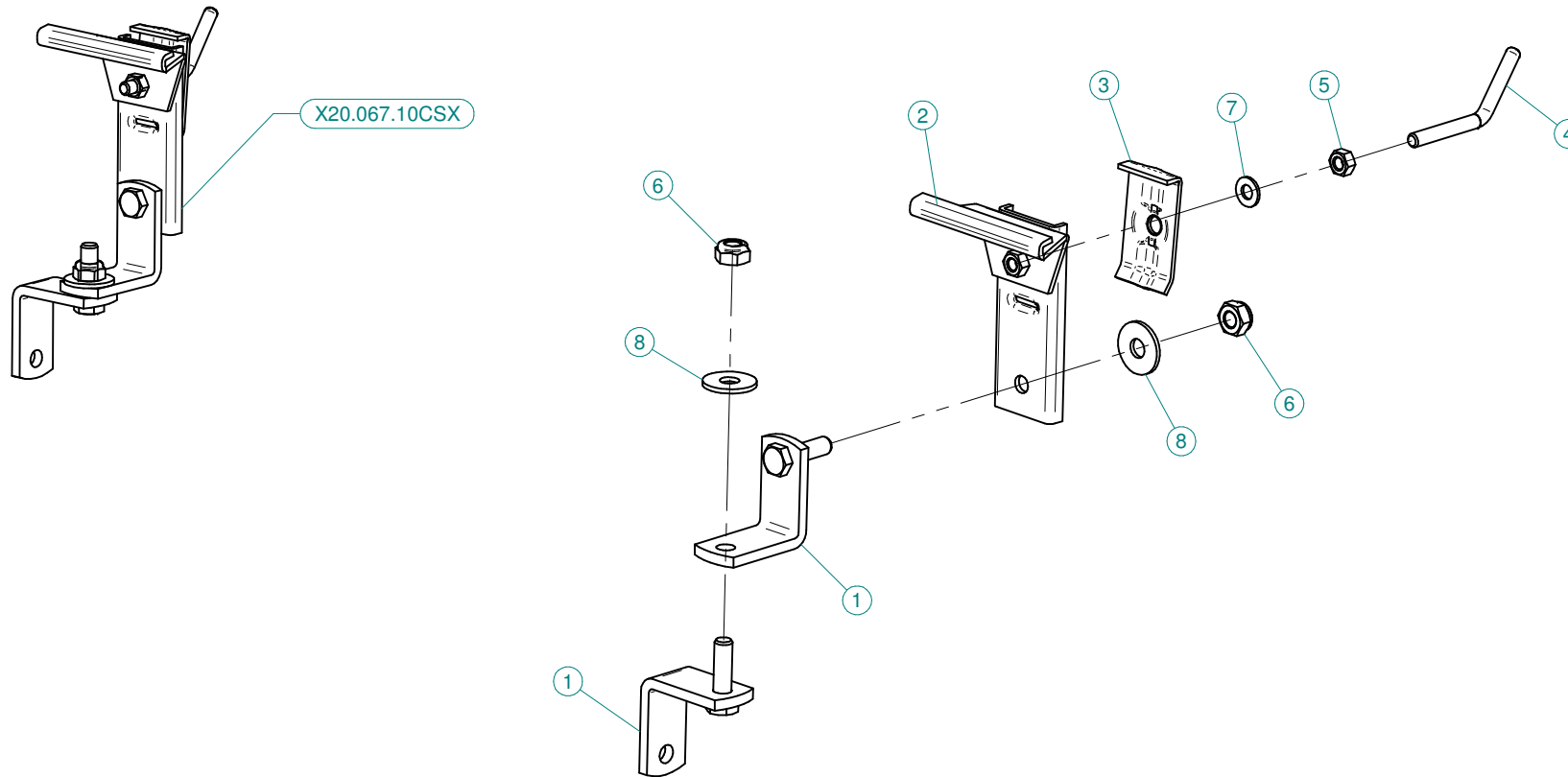

N°	Doc. Number	Titolo	Title	Q.tà
1	X04.787.000	SQUADRETTA PER DIFFUSORI BARRE	BRACKET FOR BARS	2
2	X20.067.010	SUPPORTO SCORREVOLE PER MANO A 2 DIFFUSORI	SLIDING SUPPORT FOR A HAND 2 DIFFUSERS	1
3	X20.068.000	STAFFA FISSAGGIO SCORREVOLE PER BARRA	BRACKET	1
4	X20.069.000	MANIGLIA DI BLOCCAGGIO M8	M8 FIXING LEVER	1
5	XD0.08.5587G	DADO M8 PG 5587	NUT M8	1
6	XDA.010.0BG	DADO AUTOBLOCCANTE M10	SELF LOCKING NUT M10	2
7	XRP.008.000	RONDELLA PIANA D.8 6592 ZINC.	8 D. FLAT WASHER	1
8	XRP.010.030	RONDELLA PIANA F.LARGA D.10X30 ZINC.	10X30mm D. LARGE THREAD FLAT	2

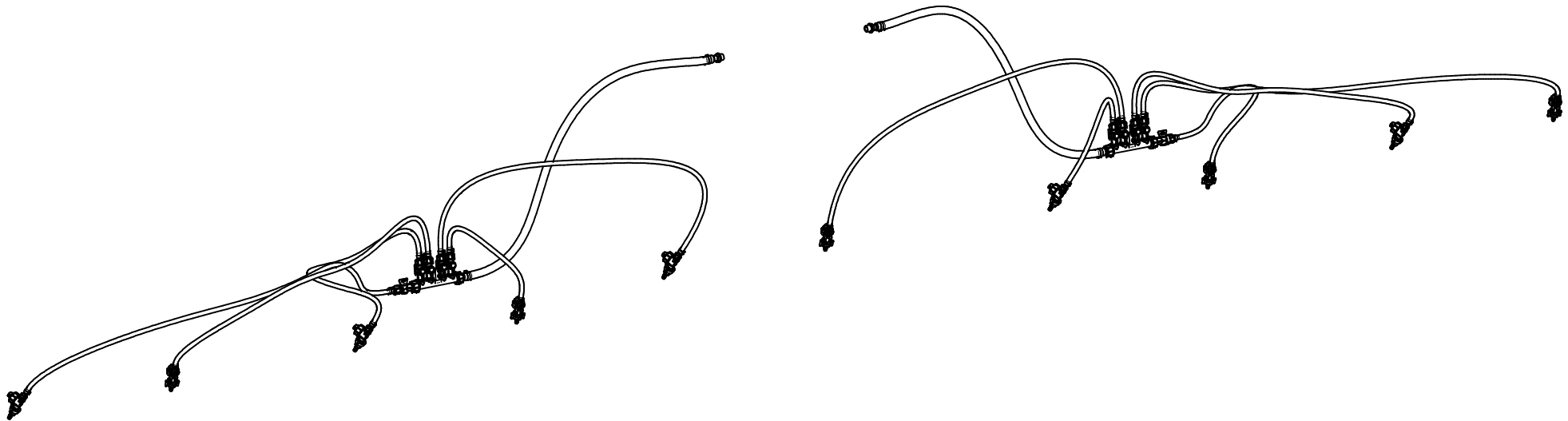

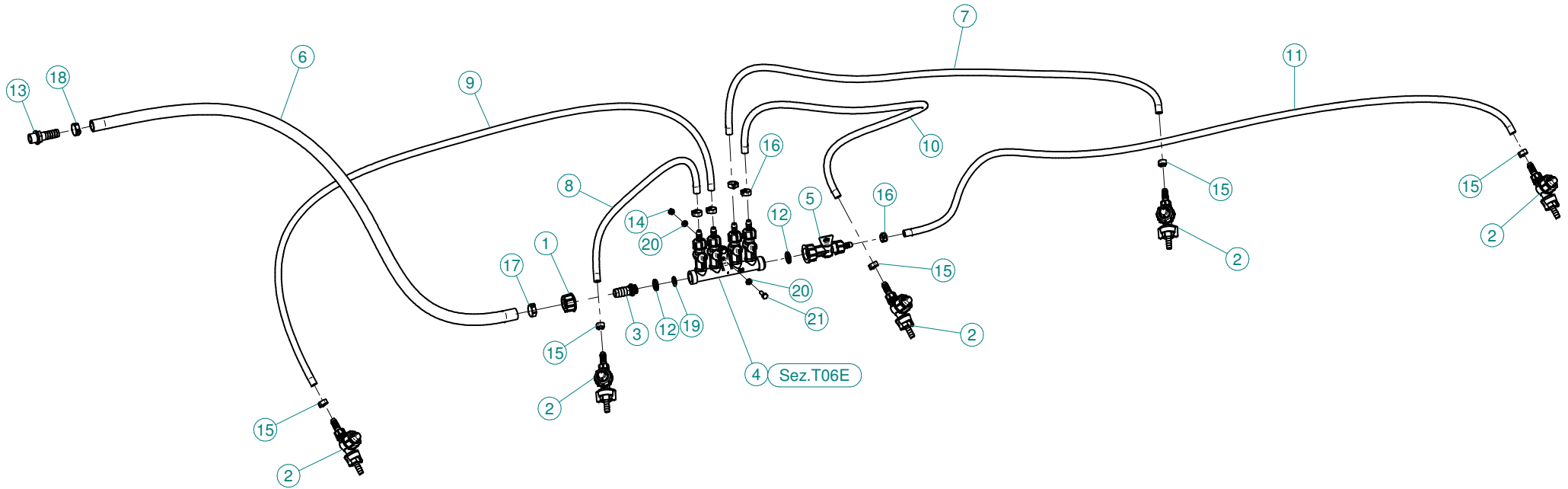

N°	Doc. Number	Titolo	Title	Q.tà
1	X00.055.045	GIRELLO 3/4" GAS ALTO	3/4" GAS FLY NUT	2
2	X00.226.105C	GETTO ANTIGOCCIA DIRITTO COMPLETO PER BARRE (0,5 bar)	COMPLETE ANTIDROP FOR BARS (0,5 bar)	10
3	X02.002.000	RACCORDO DIRITTO 3/4" P.G.16	STRAIGHT UNION 3/4" R.H.16	2
4	X02.008.204C	DISTRIBUTORE LIQUIDI A 4 RUBINETTI	LIQUID DISPENSER WITH 4 VALVES	2
5	X02.202.101C	RUBINETTO F 1/4 GAS COMPLETO	COMPLETE VALVE F 1/4 GAS	2
6	X02.211.100	TUBO Ø16x23 L=1000	HOSE Ø16x23 L=1000	2
7	X02.217.100	TUBO Ø8x13 L=1000	HOSE Ø8x13 L=1000	2
8	X02.217.140	TUBO Ø8x13 L=1400	HOSE Ø8x13 L=1400	2
9	X02.217.150	TUBO Ø8x13 L=1500	HOSE Ø8x13 L=1500	2
10	X02.217.210	TUBO Ø8x13 L=2100	HOSE Ø8x13 L=2100	2
11	X02.217.260	TUBO Ø8x13 L=2600	HOSE Ø8x13 L=2600	2
12	X02.349.000	GUARNIZIONE PIANA D.17X23X3	17X23X3 FLAT GASKET (G4000B)	4
13	X21.260.000	RACCORDO DIRITTO PG D. 16 FIL. M 3/4"	STRAIGHT HOSE R.H. D. 16 THR. M 3/4"	2
14	XD0.06.5588G	DADO M6 6S PG 5588 ZINC.	M6 6S BIG LEAD NUT 5588	4
15	XFC.012,5.014	FASCETTA COBRA SL030705	KOBRA CLAMP SL030705	10
16	XFC.013,5.015	FASCETTA COBRA SL030710	KOBRA CLAMP SL030710	10
17	XFC.022,5.024	FASCETTA COBRA SLO30756	KOBRA CLAMP SLO30756	2
18	XFC.023,5.025	FASCETTA COBRA SLO30761	KOBRA CLAMP SLO30761	2
19	XOR.000.117	OR D.13,1X2,62	13.1X2.62 O-RING GASKET	2
20	XRP.006.000	RONDELLA PIANA D.6 6592 ZINC.	6mm D. FLAT WASHER	8
21	XTE.006.020T	VITE TE M6X20 5739 ZINC.	BOLT TE M6X20 5739	4

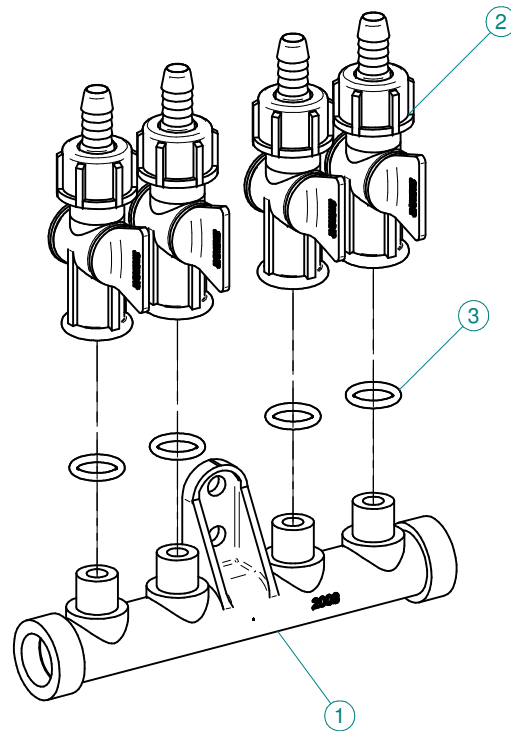

N°	Doc. Number	Titolo	Title	Q.tà
1	X02.008.000	DISTRIBUTORE LIQUIDO TESTATE	SPRAYHEADS LIQUID DISTRIBUTOR	1
2	X20.202.200	RUBINETTO P.G. D.10 F.1/4" GAS	VALVE F. 1/4 GAS WITH RUBBER HOLDER D.10	4
3	XOR.000.117	OR D.13,1X2,62	13.1X2.62 O-RING GASKET	4