

ESSE 4E 

OPERATION AND MAINTENANCE INSTRUCTIONS

cima[®]

atomizzatori e impolveratori

Dear Customer, thank you very much!

*We want to congratulate with you, for having chosen a **cima**[®] Xi ghYf.*

Your choice shows the wisdom of the well-informed Purchaser, aware of the fact, that the required features of quality, technique and reliability must be satisfied at the right price!

Our continuous engagement in R&D and in testing our machines allows us to realize products able to offer the best performances, a high reliability and a great easiness of use at the same time !

Our first goal, is to get our Customers happy for having met us!

The "Spare parts catalogue" of this duster is available in the "restricted area" on website www.cima.it.

In order to accede, use:

User name: **duster**
Password: **546236NQ**

3- POINT MOUNTED DUSTER

Esse 4E

Serial Number:

(Publication n° LUM-S4E-01-EN)

OPERATION AND MAINTENANCE INSTRUCTION

cima[®] S.p.A.

27040 Montù Beccaria - Loc. Molino Quaroni - (PV) - ITALIA

Tel. +39.0385.246636 r.a. - Fax +39.0385.246637

<http://www.cimaitalia.com>

LISTING OF VALID PAGES

This publication consists of 32 pages, subdivided as follows:

N° OF PAGE	REVISION	BASE
from I to VI	01	January 2012
from 1 to 26	01	January 2012

ADDITIONAL RECORDS AND VARIANTS

REVISION	DESCRIPTION
00	First Edition, March 1995
01	Second Edition, January 2012
03	
04	
05	
06	
07	
08	

GENERAL INDEX

1	FOREWORD	1
1.1	CHECK TO BE CARRIED OUT AT MATERIAL RECEPTION	1
1.2	PUBLICATION IDENTIFICATION	1
1.3	ATTACHED PUBLICATIONS	1
1.4	PURPOSE OF PUBLICATION	1
1.5	REFERENCE TO REGULATIONS	1
1.6	USING THE MANUAL	2
1.7	UPDATES	2
2	GLOSSARY	3
2.1	TERMINOLOGY	3
2.2	ABBREVIATIONS	3
2.3	DECALS	3
3	GENERAL INFORMATION	6
3.1	MACHINE IDENTIFICATION	6
3.2	TECHNICAL ASSISTANCE	6
3.3	SAFETY NOTICES	6
3.3.1	General	6
3.3.2	Protection against the fires	7
3.4	SAFETY SYSTEMS	7
3.5	HANDLING OF AGRO-CHEMICALS	8
3.5.1	STORAGE	8
3.5.2	SPECIFIC EQUIPMENT	9
3.5.3	DISPOSAL OF EMPTY CONTAINERS AND AGRO-CHEMICALS RESIDUES	9
3.5.4	PERSONAL MEANS OF PROTECTION	9
4	MACHINE'S STRUCTURAL ANALYSIS	11
4.1	FRAME	11
4.2	MULTIPLIER	12
4.3	FAN	12
4.4	TANK CONICAL SUPPORT	12
4.5	TANK	12
4.6	CAPACITY REGULATOR	12
4.7	TECHNICAL DATA	13

4.7.1	Dimensions and weight (without head)	13
4.7.2	Technical specifications	13
5	COUPLING MODALITIES	13
5.1	HITCHING TO THE TRACTOR	13
5.2	MOUNTING OF THE TRANSMISSION SHAFT	14
6	DISTRIBUTION DEVICES	15
7	FILLING	16
8	CONSTANT DELIVERY CONTROL	17
9	OPERATING PROCEDURES	17
9.1	PRELIMINARY OPERATIONS TO TREATMENT	17
9.2	PREPARATORY OPERATIONS TO TREATMENT	18
9.3	THE TREATMENT	19
9.4	END OF TREATMENT - STORAGE	19
9.4.1	DAILY	19
9.4.2	END OF SEASONAL CYCLE	19
10	LIFTING AND TRANSPORT	20
10.1	LIFTING AND TRANSPORT OF THE DUSTER	20
11	MAINTENANCE OPERATIONS	21
11.1	GREASING	21
11.2	LUBRICATION	21
12	TROUBLESHOOTING	22
13	REPAIRS ALLOWED	23
14	INTEGRATIVE DIAGRAMS	23
14.1	DUSTER DIAGRAM	23
15	NOISE LEVEL	24
16	ATTACHMENT: DECLARATION OF COMPLIANCE	25

17	WARRANTY	26
17.1	Warranty	26
17.2	Reporting defects in goods	26
17.3	To pass safety information	26
17.4	Validity and acceptance	26

1.1 - CHECKS TO BE CARRIED OUT AT MATERIAL RECEPTION

At reception of the machine, make sure that this one is complete and in good condition in every part. If any damaged parts are found out, timely inform about that the machine Distributor, or directly contact C.I.M.A. SpA.

Upon receipt of the machine, expressly verify the following conditions:

- that the machine is delivered assembled in all its parts, and that the equipment fully complies with the requested configuration;
- that all the protections are both present and firmly fastened;
- that the oil level inside the multiplier gearbox is correct;
- that the parts of the machine ARE NOT damaged because of any bumps suffered during the transport.

1.2 - PUBLICATION IDENTIFICATION

The "OPERATION AND MAINTENANCE INSTRUCTIONS" manual is an integrative part of the duster. It is identified by a Publication No. located on the frontispiece, and through which the document can be identified, traced and/or subsequently referred to.

The information elements contained herein are updated as at the date of publication. C.I.M.A. S.p.A. reserves the right to modify its machines without notice, with the purpose of applying technical enhancements, and it declines all responsibility for possible omissions from the publication. All right reserved. No parts of this book may be reproduced or utilized in any form or by any means, electronic or mechanical, including photocopying, recording, or by any information storage and retrieval system, without premission in writing by C.I.M.A. S.p.A.

1.3 - ATTACHED PUBLICATIONS

- Spare parts catalogue.

1.4 - PURPOSE OF PUBLICATION

All indications contained in this manual are aimed at the user of the duster.

The duration of the machine and its operation, the operator's safety and the respect for the environment are dependent upon scrupulous observance of the stated norms.

Before making use of the duster, the user must read, understand and abide by all regulations listed in this manual.

1.5 - REFERENCE TO REGULATIONS

This manual was set out conforming to the regulations contained in following documents:

- Directive 2006/42/CE: Attachment 1 point 1.7.4;
- UNI 10653: Technical Documentation;
- UNI 10893: Technical Documentation.

1.6 - USING THE MANUAL

Read every part of this manual, paying attention to the **WARNING** and **DANGER** indications both on the text and on the machine or on components.

All operations suggested by the manual will have to be followed with the utmost care and only after having understood the negative consequences of improper usage.

The following “**symbols**” are used within the text in order to highlight and visually identify the importance of the various types of information:



Indicates important additional information



Non observance can result in permanent damage to the duster.



Highlights possibly dangerous situations to people.

The manual, with relevant attachments and possible integrating issues, must be kept with the utmost care and must always be complete, integer and legible in every part. Should it be mislaid it is imperative to immediately request a duplicate from C.I.M.A. S.p.A. Should the decals originally applied on the machine be mislaid, damaged or become incomprehensible, they should be promptly replaced.

For every type of distribution device (Head) delivered with the sprayer, a specific user and maintenance manual is attached. All the head manuals must always accompany the one of the machine.



- **The manual must always be kept for the duster's whole operational life.**
- **Any modification received must be permanently inserted in this publication.**
- **The manual must be ceded with the duster should this be sold.**

1.7 - UPDATES

Possible updates that C.I.M.A. S.p.A. will provide the owner of the duster will be accompanied by instructions to insert in this publication.

Should the machine be sold, the owner must inform the new purchaser that he should notify C.I.M.A. S.p.A. of his address in order to receive possible future integrating issues and/or updates.

2.1 - TERMINOLOGY

The terms FRONT, REAR, RIGHT and LEFT utilised in this publication refer to the duster as seen by an operator from behind the operative unit along the drive line and facing it: **the rear part** of the machine is that closest to the operator, and is where the distribution device (Head) is mounted - and **the front part** is the one that gets attached to the tractor.

2.2 - ABBREVIATIONS

cm	centimetres
CV	Horse Power (DIN)
g	grams
h	hour
ha	hectare
ha/h	hectare per hour
l	litres
l/h	litres per hour
l/min	litres per minute
kg	kilogram
kg/cm ²	kilograms per square centimeter (atmosphere)
km	kilometre
km/h	kilometres per hour
kW	kilowatt
Lm	width in metres
m	metre
m ³ /h	cube meters per hour
m/s	metre per seconds
Mesh	N° of meshes per linear inch
Micron	1/1000 of millimetre
mm	millimetres
PTO	power take-off
RPM	revs per minute
s	seconds

2.3 - DECALS

The safety and use/maintenance decals applied to the machine are described in the following paragraph.



Every decal is marked with its part number, in case it needs to be replaced.

The arrangement of the adhesives on the machine is shown in the following pictures.

Safety decals



95001

- STOP THE ENGINE AND REMOVE THE KEY FROM THE TRACTOR'S CONTROL PANEL BEFORE CARRYING OUT ALL MAINTENANCE OR REPAIR OPERATIONS
- CONSULT THE USER AND MAINTENANCE MANUAL BEFORE USING OR INTERVENING ON THE MACHINE



95011

- DANGER: ROTATING COMPONENTS. BEFORE LIFTING THE LID, STOP THE TRACTOR, TAKE THE KEY OUT OF THE CONTROL PANEL AND MAKE SURE THAT ALL COMPONENTS HAVE STOPPED.



95005

- DANGER, PARTS IN MOTION. BEFORE REMOVING PROTECTION GUARDS, STOP THE TRACTOR, REMOVE THE KEY FROM THE TRACTOR'S CONTROL PANEL AND ENSURE THAT ALL MOVING PARTS HAVE STOPPED.



95006

- WARNING: CONSULT THE USER AND MAINTENANCE MANUAL BEFORE USING OR INTERVENING ON THE MACHINE



95010

- MAXIMUM OPERATING SPEED OF THE DRIVE OUT-LET (PTO): 540 RPM

Use and maintenance decals



95059

- HOOKING POINT FOR THE LIFTING OF THE MACHINE



95053

- GREASE EVERY 50 HOURS: ANTI-DUST GASKET



95068

- SOFTLY ENGAGE THE PTO; FAN START-UP MUST BE GRADUAL



- DELIVERY GRADUATION

Positioning of the safety, use and maintenance decals

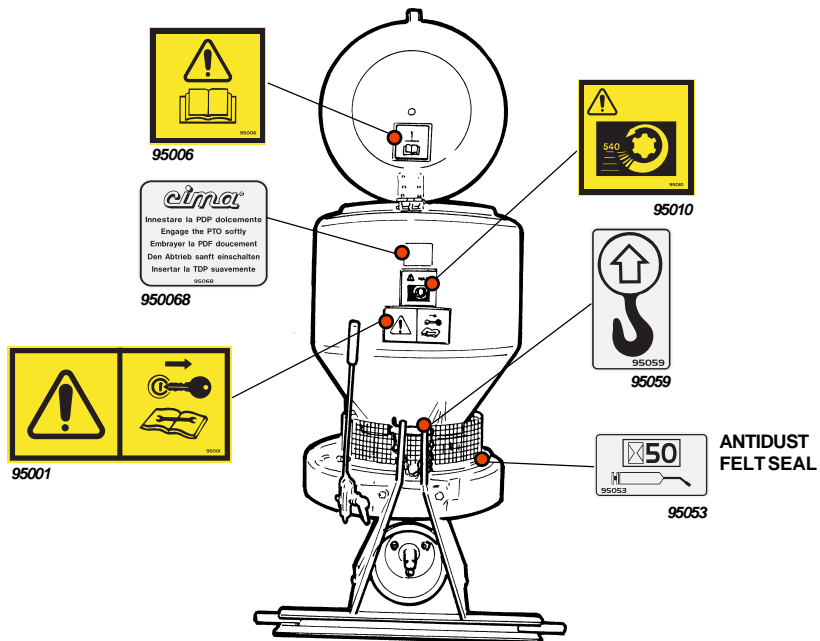

UMS4002

Front view

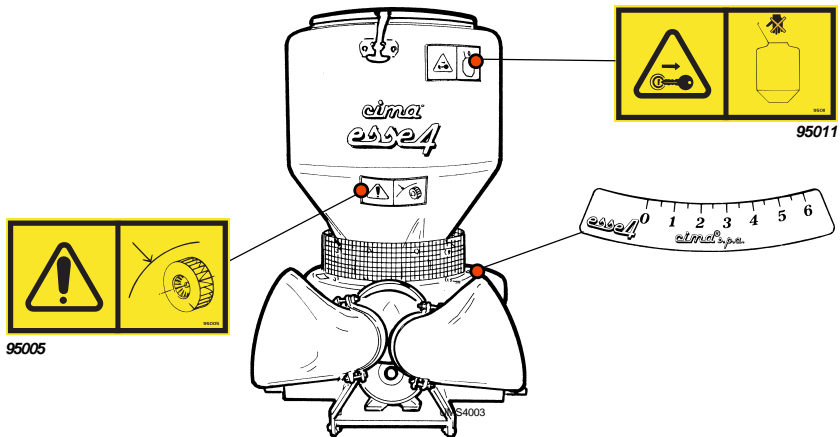

Rear view

3.1 - MACHINE IDENTIFICATION

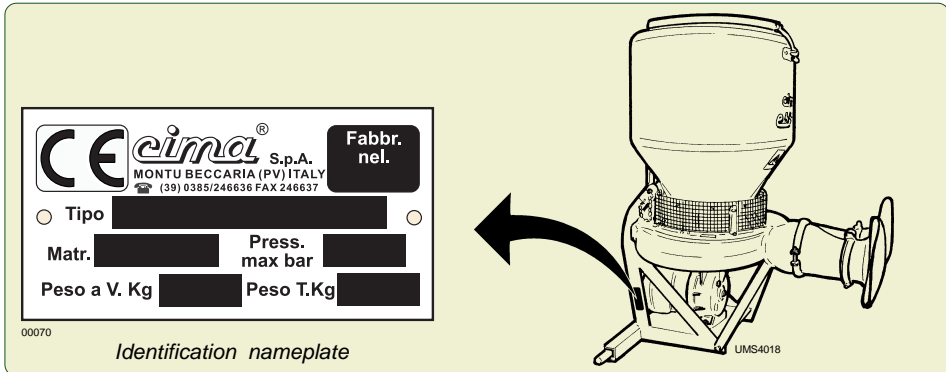

3.2 - TECHNICAL ASSISTANCE

C.I.M.A. S.p.A. is at the complete disposal of customers for any type of intervention. The names and addresses of its service network, both in Italy and in foreign countries, can be requested from:

C.I.M.A. S.p.A. - 27040 Montù Beccaria - Loc. Molino Quaroni (PV) - ITALIA
 tel. +39-0385-246636 - fax +39-0385-246637
 e.mail service@cima.it

3.3 - SAFETY NOTICES

3.3.1 - General



The personnel appointed to the use of the machine must have acquired an exhaustive knowledge of the same one and of the dispositions contained inside this publication, be able to properly interpret the symbols of the adhesives applied on the machine, and, in addition, perfectly know the safety and the work hygienic rules in force in the country where the machine itself is to be used.

All the preparation, use, maintenance, moving and transporting operations must be carried out of the regulations contained in this publication.



IT IS FORBIDDEN TO UTILISE THE DUSTER FOR PURPOSES OTHER THAN FOR ITS INTENDED USE, SINCE IT WAS MANUFACTURED ONLY FOR FOR DISTRIBUTING ANTI-MILDEW POWDERS ON AGRICULTURAL CULTIVATIONS.

It is necessary to scrupulously abide by the following general norms:

- always stop the tractor's engine before carrying out any operation on the duster;
- check that the power of the tractor is compatible with the duster to be used;

- verify that the maximum weight admitted on the three-point hoister of the tractor is compatible with the weights of the duster to be used;
- before utilisation, check the correct tightening and securing of the machine's various components, paying particular attention to the safety protections and to the moving parts;
- only utilise protected cardan shafts provided with CE conformity certification. Carry out the assembly only if the drive outlets of both tractor and duster are equipped with the protection counter-guard;
- check that the cardan shaft is blocked by the appropriate anti-rotation chains;
- keep people and animals away from the machine before starting it up;
- don't wear articles of clothing that might get caught in moving parts;
- keep to a low speed while negotiating bumps or crossing ditches;
- during the use of the machine, the operator must have a sufficiently good visibility on the working areas, consequently it is recommended to keep both clean and efficient the cab windows and the rear-view mirrors;
- always stop the tractor's engine and actuate the parking brake before carrying out any operation on the sprayer;
- never leave the machine unguarded, when the key is inserted inside the tractor control panel.



- **All of the maintenance and repair operations should be carried out only after having carefully cleaned all the parts of the machine.**
- **The utilisation of the air flow for purposes other than those expressly concerning distributing anti-mildew powders on agricultural cultivations is not permitted.**

3.3.2 - PRECAUTIONS AGAINST THE FIRES

Don't approach either flames or heat sources to the machines. The presence of lubricants and of chemical product residuals make them potentially flammable.



- **It is forbidden to make weldings if ammonium salts have been used or on parts not perfectly cleaned from any sulphur residuals.**
- **It is forbidden to use the machine if any free flames are present or in proximity of any incandescent material, fire residuals or glowing fires.**

3.4 - SAFETY SYSTEMS

All machine moving parts are suitably protected by guards and highlighted through the use of warning decals.



- **It is forbidden to use the machine with these guards removed.**
- **Before removing the protection, stop the tractor's engine and remove the key from the control panel.**
- **Before beginning the distribution of the product, make sure that the lid is closed.**



THE OWNER AND/OR THE OPERATOR OF THE DUSTER ARE NOT PERMITTED TO MODIFY THE STRUCTURE OR THE SPECIFIC OPERATION OF THE DUSTER ITSELF. ANY REPAIRING INTERVENTION HAS TO BE CARRIED OUT EITHER AT THE DISTRIBUTORS' OR AT THE C.I.M.A. S.p.A. AUTHORIZED WORKSHOPS, OTHERWISE ANY KIND OF WARRANTY IMMEDIATELY CEASES AND C.I.M.A. S.p.A. IS CLEARED OF ANY CONSEQUENT AND/OR IMPLIED RESPONSIBILITY.

The pictures illustrate the machine's guarded parts:

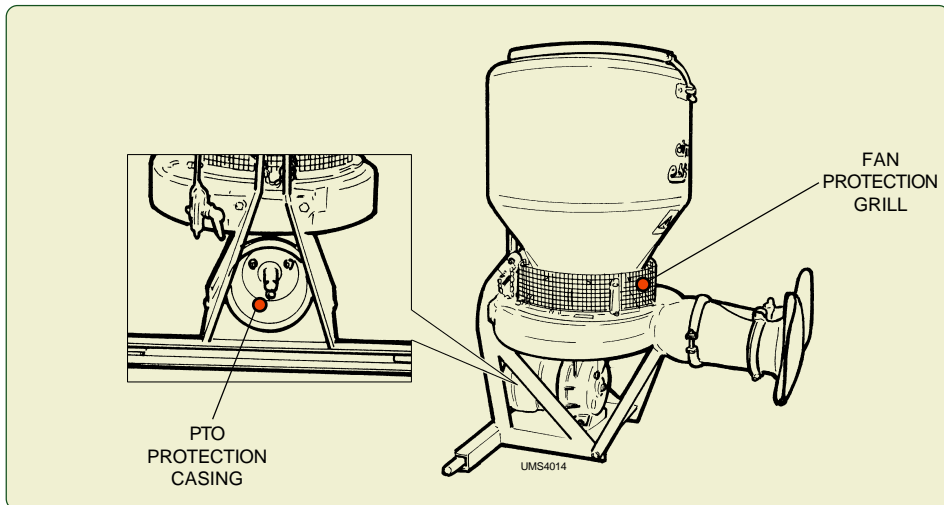

3.5 - HANDLING OF AGRO-CHEMICALS

The **operator** could become contaminated due to accidental spray, contact or inhalation of products or crop-spraying mixtures.

The **environment** could become polluted by mixture over-spills, puncturing of containers, uncontrolled storage of used and unwashed containers or spillage into waterworks.

In order to avoid these risks the preparation and filling operations must be carried out in suitably appointed and adequately equipped sites.

3.5.1 - Storage

Fixed / stationary: the site used must be well ventilated and secured by lockable doors in order to prevent even accidental access by children or unauthorised persons.

Mobile: the carrier equipment must be properly locked and kept under conditions whereby access by children or unauthorised persons can be prevented during the absence of the operator. All full or partially utilised containers must be secured against tipping, falling or breakage during transportation. Both types of storage must:

- have a suitable container for the storing of empty packaging materials should a specific storage area not be available;
- have a clean water supply readily available for washing, by means of a specific container or through connection to the waterworks system;
- have the use of fire extinguishers, should flammable products and substances be stored.



- All packages, whether whole or partially utilised, must be stored in their original packing and with the warning instructions clearly displayed and legible.
- The storage indications must always be scrupulously adhered to, as well as their utilisation and possible disposal as suggested on the product's original packaging.

3.5.2 - Specific equipment

The site at which the preparation and filling out will take place must provide for:

- all the equipment necessary to the precise measuring of both the water quantity and the dose of product to be mixed in the tank at every filling;
- all the equipment and means useful to the preparation of the mixture and for the cleaning of the operator in case of contamination;
- all tools necessary to facilitate the direct introduction of the agro-chemicals in the tank;
- the allocation of clothing and specific equipment in order to avoid contamination by contact or inhalation during the whole operative phase of the intervention;
- the availability of proper equipment able to stop the uncontrolled spilling and flowing of the mixture;
- a retaining valve on the feed pipe when the filling of the tank takes place directly from the waterworks system.

3.5.3 - Disposal of empty containers and agro-chemicals residues

Agro-chemicals are classified as “special” waste and their disposal must take place separately from “urban” wastes.



Empty packaging and contaminated containers to be done away with cannot be dispersed, burned or buried.

The washing water for the cisterns and the tools utilised for the preparation of mixtures cannot be emptied on the ground, spilled into the sewage system or in waterways and rivers.

The disposal of special wastes is regulated by specific norms. In order to perform this operation it is necessary to obtain the relevant information from the Local Offices specifically appointed to rule on this subject. The non compliance with these regulations can cause considerable damage to persons and animals as well as polluting the environment.

3.5.4 - Personal means of protection

The toxicity of agro-chemicals forces persons working with them to wear adequate protective clothing and accessories in order to avoid risks of contamination by contact or inhalation.

In each of the following work stages:

- filling of tanks and adding of the agro-chemical,
- dusting and spraying,
- adjusting of the sprayer,
- emptying and cleaning of the tank,
- replacement of the agro-chemical,
- maintenance interventions,

it is necessary to wear personal protection clothing and accessories.

The following must be worn:

- Polyethylene or polyvinyl gloves.
- Full, waterproof cotton overalls, in order to guarantee transpiration, fitted with polypropylene side flaps.
In commerce, one-time 'tyvek' overalls are available which, after use (see picture), must be disposed of according to the modalities applicable to toxic waste.
- A protective half-mask in polychloroprene rubber with 1 or 2 filters. Filters for gases and organic fumes, of European A1-class vapours, are envisaged and these can be combined with anti-dust models of P1 European class, for harmful mists and powders, or P2, for harmful and toxic mists and powders.

**The filters must be replaced:**

- when the smell/taste of agro-chemicals can be detected, and that of active A1-class carbons;
 - when difficulty in breathing is experienced for the anti-dust filters of class P1 and P2.
- In any case it is necessary to make use of all personal means of protection as suggested by the manufacturers.

4 MACHINE'S STRUCTURAL ANALYSIS 4

The pictures indicate the position of the main components of the duster.

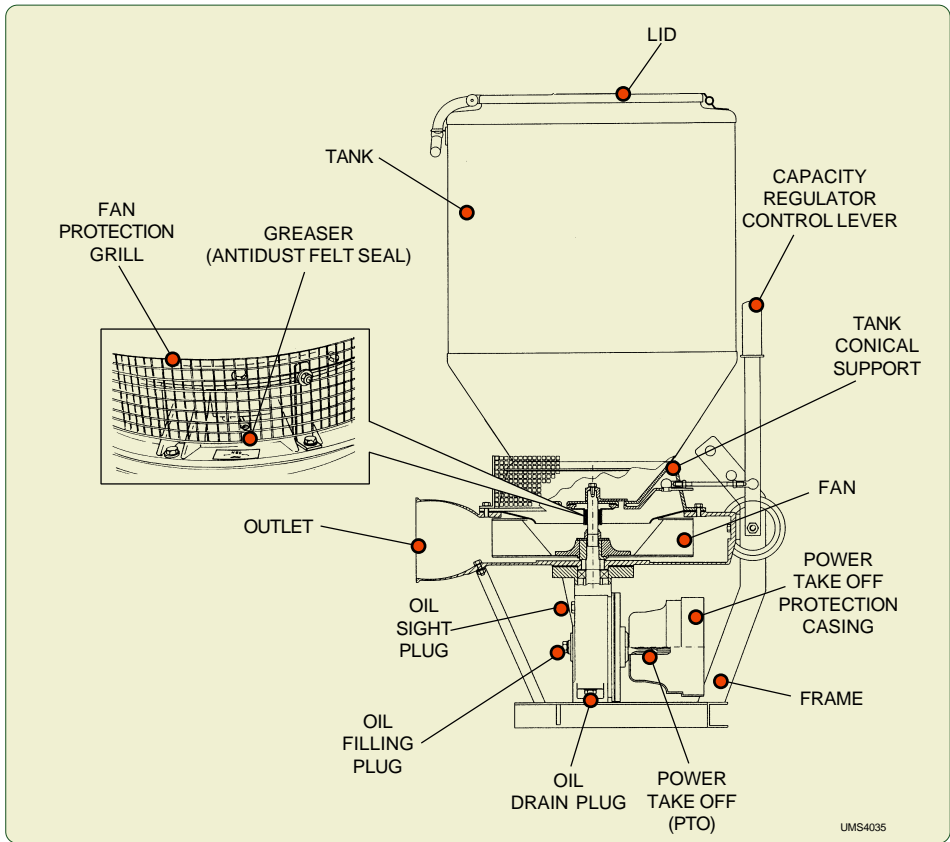

4.1 FRAME

The frame may be coupled to hydraulic hoists of class "1". The diameter of the gudgeon is 22mm. The pin of the third point is 19mm. in diameter.

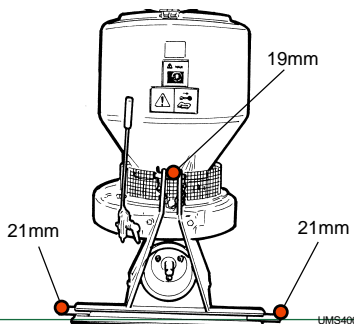

4.2 - MULTIPLIER

- Aluminum **gearbox**. On the side opposite the PdP. It has a sight plug for filling and checking the oil level; at the center there is another service plug to make interventions on the conical couple easier; underneath discharge plug.
- **Conical Couple** with high-tensile steel helicoidal teeth, dimensioned with a wide safety margin that works in oil bath.
- PTO **protection casing** attached on the multiplier cover.



The multiplier should work with PdP at 540 RPM. This condition **MUST ALWAYS BE OBSERVED** during the machine's operation.

4.3 - FAN

- Aluminum **carter** with rear outlet.
- Centrifuge **fan** enclosed in steel, balanced dynamically. To absorb the tears of departure or sudden stops, the pinion of the multiplier transmits motion to the fan via a brass hub, provided by six rubber shock absorbers.

4.4 - TANK CONICAL SUPPORT

- It is made of aluminum and has 4 holes to let the powder fall. A distributing mixer controlled by the multiplier rotates. Underneath it, there is a register with 4 holes which allows the adjustment of the powder distribution.
- Between the lid with bush, which attaches the register to the bottom, and the pinion driving the mixer, is a felt seal against powders. Its functionality is guaranteed by a greaser inserted on the lid.

4.5 - TANK

- Realized in steel sheet, the tank is fastened to the conical support and provided with an overturning cover with locking rubber handle.



- **Before opening the lid, stop the tractor and take the key out of the control panel.**

- **Check that the lid is closed before starting the tractor again.**

4.6 - CAPACITY REGULATOR

The threaded rod connects the appendix of the regulation lock to the control lever fastened on duater frame.

The small square-type indicator slides on a graduated scale from 0 to 6 fixed on the fan carter. It shows the width of the opening of the distribution holes. "0" means full closure, "5" maximum delivery. The handle locks the small square that keeps the opening of the control lever in the desired position.

4.7 - TECHNICAL DATA



The duster's weight indicated in the table doesn't include the weight of the cardan shaft nor that of the head applied to the machine. The weight of the single distribution heads is indicated

4.7.1 Dimensions and weights (without head)

Length	770 mm
Total width	815 mm
Total height	1150 mm
Weight, empty	69 kg
Weight, full load	169

4.7.2 Technical Specification

Tank capacities	150 litres
Tank capacities, with sulphur	100 kg
Multiplication ratio	1:5,8
PTO shaft	1 3/8" SAE (DIN 9611/A)
Multiplier oil - SAE 90	0,7 kg
Rear outlet diameter	130 mm
Fan diameter	400 mm
Fan speed	3130 RPM
Air flow rate	2100 m ³ /h
Air speed	90 m/s
PTO power absorbed	5,9 kW (8 CV)

5

COUPLING MODALITIES

5

5.1 - HITCHING TO THE TRACTOR



Check that the tractor's "permissible carried weight" and the "rear overhang allowed" are compatible with the weight and dimensions of the fully loaded duster and complete with equipment mounted for the treatment (see Paragraphs "3.1" - "4.7" and "6").







The tractor's power take-off (PTO), under all utilisation conditions, must provide a power exceeding that absorbed by the duster.

COUPLING POWER WITH TRACTORS OF AT LEAST: 15 CV = 11 KW

The duster should be mounted on a flat surface, taking care to clear away all people not involved in the operation, including children and animals.

EXECUTION:

- Loosen the chains of the lifter arms.
- Start the tractor and take the lifter's arms to the level of the machine's pins.

3.   Stop the tractor and remove the key from the control panel.
4. Insert the toggle joints on the machine's pegs, locking them with the clip pins.
5. Take the tension rod off of the tractor's 3rd point and locking it with the release pin.
6. Screw the tension rod slightly to put it in tension.
7. Start the tractor and hoist the duster until the 2 PTO are the same height.
8.   Stop the tractor, remove the key from the control panel and make sure that no one approaches the hydraulic controls of the lifter.
NEVER OPERATE OR STAND BENEATH THE MACHINE OR IN THE AREA THAT COULD BE INVOLVED IN ITS SUDDEN LOWERING.
9. By acting on the 3rd-point rod, vertically align the duster. **N.B.: block the 3rd-point rod with the specific lock ring.**
10. Block the coupling by tightening the chains of the hoister arms.



When the operation is completed the 2 drive outlets (PTO) must be positioned on the same axis, both in vertical and horizontal direction.

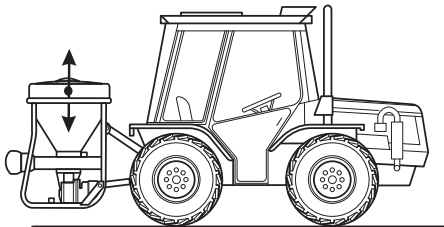

00450

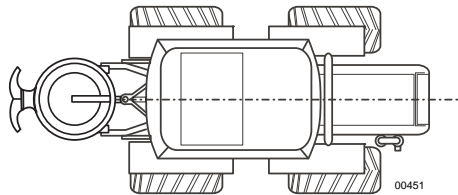

00451

5.2 - MOUNTING OF THE TRANSMISSION SHAFT



USE CARDAN TRANSMISSION SHAFTS WITH CE CERTIFICATION. OBSERVE THE REGULATIONS CONTAINED IN THE USE AND MAINTENANCE BOOK-LET PROVIDED BY THE SHAFT MANUFACTURER.



The cardan transmission shaft must work with the 2 COAXIAL drive outlets (PTO) or, should this not be possible, with the PARALLEL axles. In this case the angle of the joint **MUST NOT EXCEED 15°**.

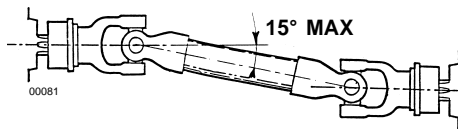

00081

Definition of the length

Set the 2 drive outlets (PTO) perfectly on the same axis and measure the distance "D" between their grooves.

Length "L" of the cardan transmission shaft (refer to the picture) to be deployed, measured between the 2 stopping pawls and with cardan shaft closed, must be 25 mm lesser than distance "D".

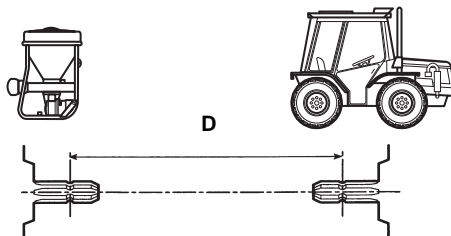

The mounting, disassembling or possible other inter-ventions on the cardan transmission shaft must be carried out with the engine switched off and with the starter key removed from the tractor's control panel.

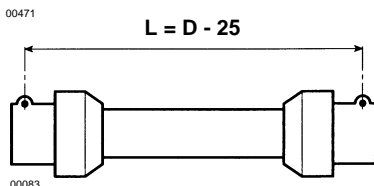

6 DISTRIBUTION DEVICES 6



All the heads CAN BE ORIENTED. The regulation of the position allows to optimise the distribution, according with the ground and with the type of culture to be treated.

- 1 - 2 SWINGING FISHTAILS SPRAYHEAD I.2V.S4.01 weight kg 7,0
- 2 - 2 SWINGING FISHTAILS SPRAYHEAD
with right or left closing I.2V.CH.S4.01 . weight kg 8,0
- 3 - SWINGING CANNONJET I.GCO.S.01 weight kg 6,5
- 4 - SWINGING CANNONJET
with additional fishtail. I.GC2.S.01 weight kg 6,5
- 5 - 2 LITTLE CANNONS SPRAYHEAD I.2C.S4.01 weight kg 8,0

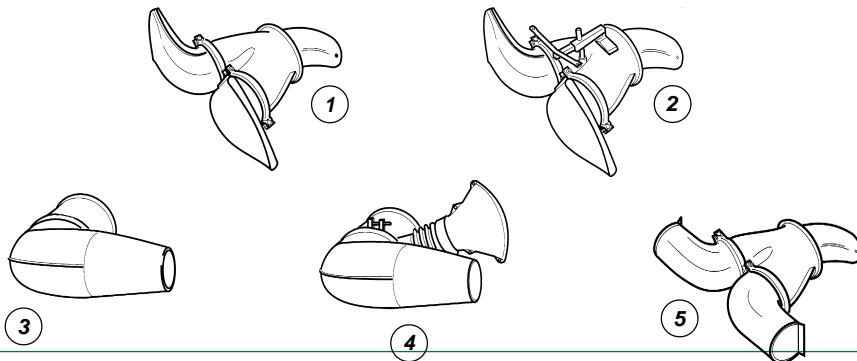





FILLING MUST BE CARRIED OUT WITH THE MACHINE ON A FLAT SURFACE. ON THE SITE, BEFORE THE OPERATION, THE DOSES TO BE POURED INTO THE TANK MUST BE PREDISPOSED.



IT IS NECESSARY TO ALWAYS MAKE USE OF PERSONAL PROTECTION.

EXECUTION:

1. Take the duster to the area in which it is to be filled and rest it on the ground.
2.   **Stop the tractor and remove the key from the control panel .**
3. Before filling the tank, stop delivery by bringing the control lever to the “0” position.
4.   **Before opening the lid, ALWAYS check that the tractor is STILL and that the key was REMOVED from the control board.**
5. Open the lid of the tank.



Avoid that both BEFORE and DURING the loading any foreign objects like stones, small pieces of metal, etc., are introduced into the tank. Even if small dimensioned, such objects could, by getting into contact with the mixer during its operation, cause some sparks inside the tank and set the duster on fire.

6. Introduce the powder product into the tank, up to its complete filling.
7. Close the lid of the tank.
8. Start the tractor, always observing the safety norms and move to the treatment place.

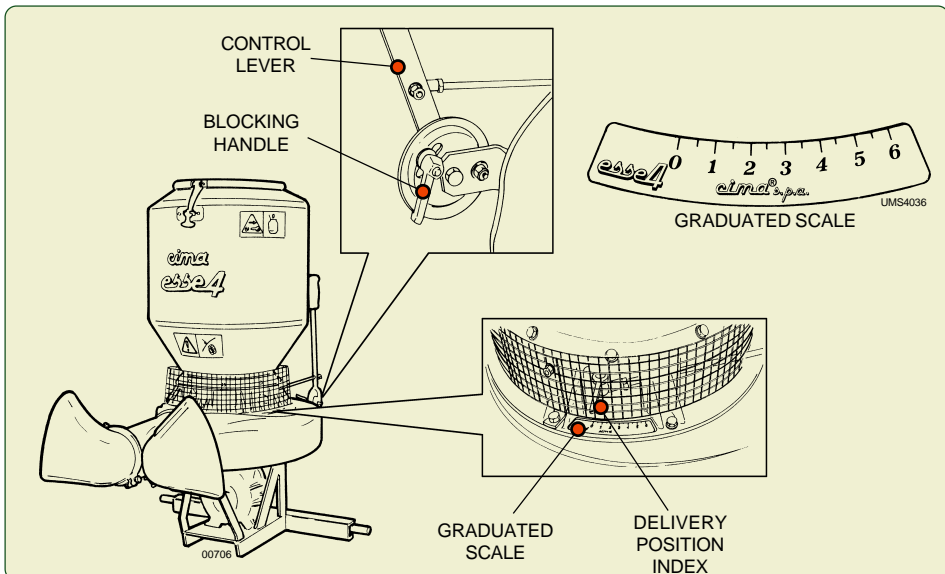



Before any transferring, make sure that the powder delivery lock is CLOSED (position "0"). If the delivery lock is open and the fan is still, the powder contained inside the tank could, as a result of the vibrations, move down and compact itself inside the fan, so causing at the machine start an excessive solicitation of the moving parts, which could consequently break. As a general precaution measure, it is recommended to avoid covering great transferring distances with the loaded tank, in order to avoid the product getting compacted inside the tank.

8



CONSTANT DELIVERY CONTROL

8

The products to be used with the duster have physical characteristics that can be strongly modified by the temperature and humidity conditions at the moment of treatment. Therefore, it is not possible to obtain and set reliable delivery amounts corresponding to the various opening indexes of the delivery holes on the tank bottom.

Usually, the machine allows deliveries from a min. 0,4 up to max. 8 kg/min., with the opening index set on No. 6. To do a treatment with constant powder distribution, it is possible to set the on-of lever at the same opening position by the locking handle.

EXECUTION:

1. Fill the duster and start the treatment,
2. Using the control lever, find the delivery position suitable for the intervention.
3. Disengage PTO without move the control lever.
4.   **Stop the tractor and remove the key from the control panel .**

5. Unswear the locking lever and move it up to reach the control lever, then strongly lock it by completely screwing it back.



This operation ensures the equal opening of the delivery holes during the entire treatment.

6. Resume the treatment.

9

OPERATING PROCEDURES

9

9.1 - PRELIMINARY OPERATIONS TO TREATMENT

The operator must:

1. Ascertain that the condition of the crops, the progress of the disease or the need for its prevention actually justify the treatment to be applied.
2. Be aware of the meteorological conditions forecast for all the time necessary for carrying out the treatment.
3. If possible, avoid carrying out the spraying in strong wind conditions or when one detects that the sprayed product disperses away from the target crop (drifting). It is advisable to suspend the treatment when the wind speed exceeds 3 m/s (10 km/hour).
4. Carefully calculate the exact quantity of the product necessary for the treatment.

5. Check that the product is available in a quantity sufficient to complete the intervention.
6. Read the product's utilisation instructions carefully, in order to ascertain the usage conditions, the correct dosage and the expiration dates.

9.2 - PREPARATORY OPERATIONS TO TREATMENT



THE FILLING MUST BE CARRIED OUT WITH THE MACHINE ON A FLAT SURFACE. BEFORE THE OPERATION, IN THE ALLOCATED AREA, THE DOSES TO BE Poured IN THE TANK MUST BE MADE READY.

Before starting the filling cycle, check:

- **MULTIPLIER OIL LEVEL.**
- **THE EFFICIENCY OF THE DISTRIBUTION DEVICE (HEAD);**

The operator must:

1. Wear adequate protective clothing and accessories such as overalls, waterproof suits, gloves, glasses and masks to shield him from contamination by inhalation or contact with the products handled.



- **Anti-dust masks don't offer any protection against toxic vapours.**
- **Avoid wearing loose clothes that might entangle with moving parts.**



 **Before opening the lid, ALWAYS check that the tractor is STILL and that the key was REMOVED from the control board.**

2. Carry out all checking and maintenance operation necessary for setting up the machine.
3. Perform loading in a well-ventilated place. If this is done outdoors, the presence of wind increases the danger of contamination.
4.  **Avoid proximity of free flames, coals or burning objects with flammable products.**
5. Put the emptied product packages in the appropriate container or in the storage rooms.
6. Clean the equipment and the tools used for preparation and keep them in the storage area for chemical products.
7. Always leave the product loading and preparation area in conditions which will not cause any contamination to persons or animals, or environmental pollution.
8. If necessary, mark the field or the machine passage area, to provide a guide for treatment and to avoid missing spots or overlapping layers.



- AT THE END OF THE OPERATIONS NECESSARY FOR TREATMENT, THE STORAGE-CONSERVATION AREAS MUST BE LEFT IN THE CONDITION REQUESTED IN ORDER TO PERFORM THEIR PREVENTIVE AND PROTECTIVE FUNCTION.

- BEFORE RE-STARTING THE TRACTOR, CLEAR PEOPLE AND ANIMALS AWAY AND NEVER LEAVE THE MACHINE UNGUARDED DURING THE PREPARATION OPERATIONS.

9.3 - THE TREATMENT



Before any transferring, make sure that the powder delivery lock is **CLOSED** (position "0"). If the delivery lock is open and the fan is still, the powder contained inside the tank could, as a result of the vibrations, move down and compact itself inside the fan, so causing at the machine start an excessive solicitation of the moving parts, which could consequently break. As a general precaution measure, it is recommended to avoid covering great transferring distances with the loaded tank, in order to avoid the product getting compacted inside the tank.

IT IS ADVISABLE TO BEGIN TREATMENT AT THE HEADLANDS.

The operator must:

1. Start the tractor, always observing the safety norms.
2. Activate the power take off (PTO) and take it to a rotation speed of **at least 500 RPM**. CARRY OUT THE TREATMENT



SOFTLY ENGAGE THE PTO.

The fan must reach the status of inertia and acquire a certain rotation speed before pushing the accelerator. Transmitting most of the motor power to overcome the starting take-off may cause the breakage of the multiplier gears. Pay special attention with double-clutch tractors.



The duster should work with PTO at 540 RPM.
NEVER EXCEED THE REGIME OF 540 RPM.



3. Use personal protection identical to that advised for the mixture, preparation and filling, if the tractor does not have a pressurized cab with aeration filters.
4. Immediately wash all elements contaminated during the treatment, promptly take off the contaminated protection clothes and discontinue the job if these cannot be replaced.
5. If the wind increases, follow the instructions given in the preliminary operations.
6. During the pauses, stop the motor, take the key out of the control panel of the tractor and lower the hoist.
7. Pay special attention when doing treatments near property lines, houses, waterways, roads or public paths.

9.4 - END OF TREATMENT - STORAGE

9.4.1 - Daily

The operator must:

1. Keep the machine in a ventilated place, sheltered from rain or sun: sunrays are the worst enemies of plastic and rubber parts.

9.4.2 - End of seasonal cycle

The operator must:

1. Carry out an accurate cleaning of the duster, emptying the tank and the distribution holes of any product residue. The operation must be done without the use of water or liquid detergents.

2. Check to see if the machine's parts and structures are working correctly. In the case of negative results, ask for the intervention of C.I.M.A. S.p.A. dealer or authorized workshop.
3. Put the machine in a ventilated place, sheltered from rain, ice and rays of sun.



The machine must be put in a secure or closed place, so as to prevent access to unauthorized personnel.

10

LIFTING AND TRANSPORT

10



THE FOLLOWING ACTIONS ARE NOT ALLOWED:

- Transporting or lifting the duster with residual quantities of product in the tank for purposes differing from its destined usage.
- The transporting of people, animals or things.
- The trailing of vehicles or equipment.



Road transport must take place in the complete observance of road regulations in force in the Country where the machine is used.

- When the footprint of the duster exceeds that of the tractor, the specific notice sign for overhanging loads needs to be attached on the rear.
- It is necessary to replicate the tractor's number plate and tail lights when these are covered by the machine.

The operator is responsible for possible defaults due to the non observance of said regulations.

10.1 - Lifting and transport of the duster



Before carrying out any operation it is essential to verify that no product residues are left in the tank.

Remove the distribution device (head) before lift the duster.

1. Check that the cables or chains used for the lifting are adequate for the weight to be lifted.
2. Hook the machine through the specific support point indicated by the specific decal on the frame, checking all the parts involved in the operation.
3. Lift the machine, verifying that it is properly balanced; position the duster on the transporting vehicle in perfectly stable conditions.
4. During transport the machine must be immobilised and fastened to the carrier by way of suitable strapping.

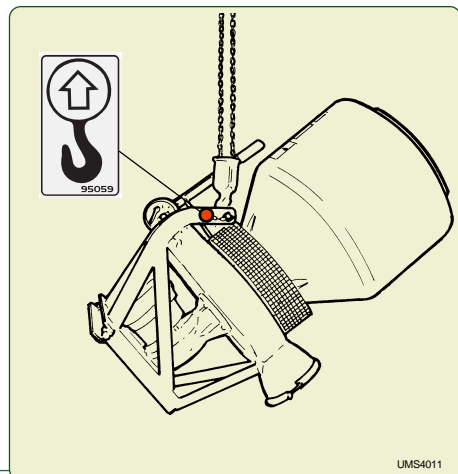

UMS4011



ALL OPERATIONS MUST BE CARRIED OUT WITH THE ENGINE SWITCHED OFF AND WITH THE IGNITION KEY REMOVED FROM THE CONTROL PANEL.

11.1 - GREASING

At the beginning of the treatment season and after every 50 hours work, grease the felt seal with EP type NGL2 class grease.



Accurately clean the greaser before use: dirt could be introduced together with grease.

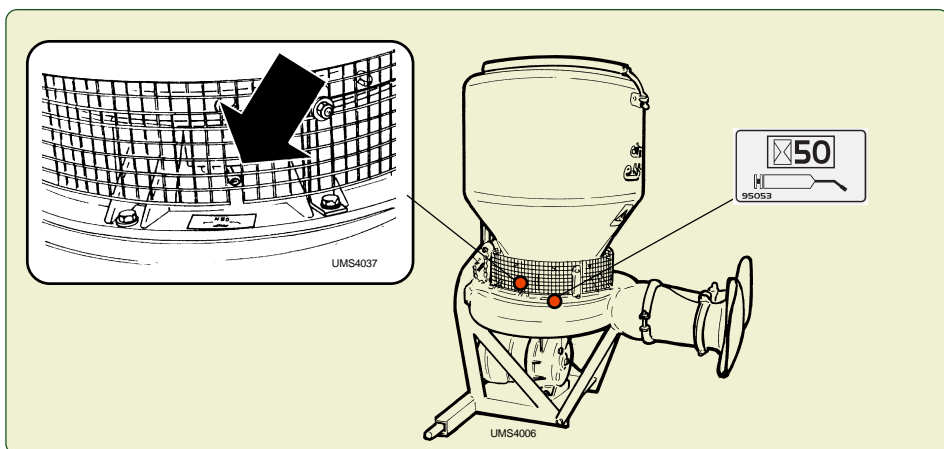

11.2 - LUBRICATION



When the machine is sitting on a flat surface, the oil level inside the multiplier should always be visible through the sight plug situated on the guard cover.

The multiplier oil has to be replaced after **1000 working hours**. A plug situated under the multiplier box allows for the discharge of the oil.

It is absolutely necessary that the oil is always kept at the required level. Any possible filling up has to be carried out through the filling cap, either by inclining or by laying down the machine: **always use oil SAE 90.**



At the beginning of the treatment season and before every intervention, check the oil level in the multiplier guard.

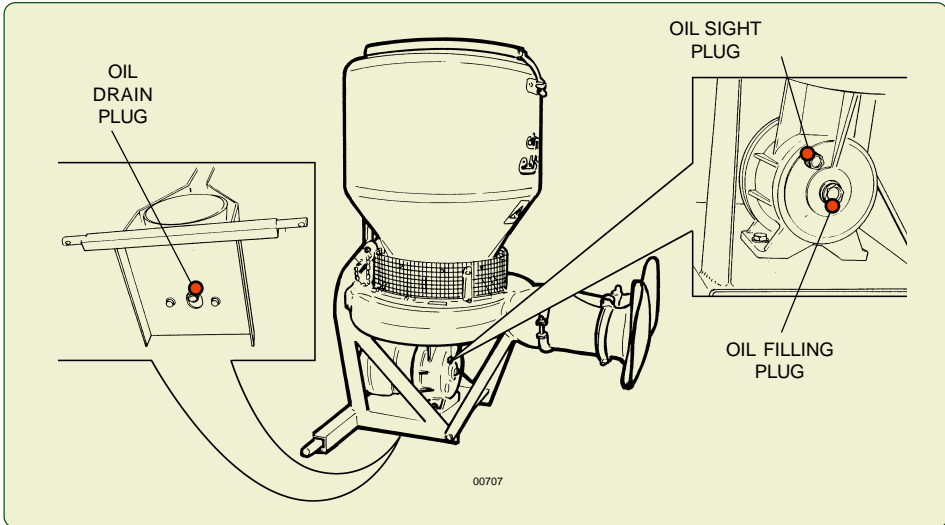

12

TROUBLE SHOOTING

12

A. PROBLEM: Oil leakage from the cover of the multiplier box

1. CAUSE: The cover seal is defective.
REMEDY: Refer to CIMA after sale service.
2. CAUSE: The sealing ring on the cover is defective.
REMEDY: Refer to CIMA after-sale service.

B. PROBLEM: Vibration of the ventilator group

1. CAUSE: The fan is dirty or out of balance.
REMEDY: Refer to CIMA after-sale service.
2. CAUSE: The PdPs are not aligned or are not parallel.
REMEDY: Position the PdPs in the correct way.

C. PROBLEM: Abnormal and constant noise with vibrations

1. CAUSE: Breakage of the multiplier bearings.
REMEDY: Refer to CIMA after sale service.

D. PROBLEM: Non-delivery of powders

1. CAUSE: The feeding holes on the tank bottom are clogged.
REMEDY: Clean them.
2. CAUSE: Caking of the tank's contents.
REMEDY: Break up the powder.

E. PROBLEM: Distribution on the two sides is not uniform

1. CAUSE: The compensation plate of the head has moved.
REMEDY: Adjust it in order to get a uniform distribution.

13 REPAIRS ALLOWED 13



THE OWNER AND/OR THE OPERATOR OF THE DUSTER ARE NOT PERMITTED TO MODIFY THE STRUCTURE OR THE SPECIFIC OPERATION OF THE DUSTER ITSELF. ANY REPAIRING INTERVENTION HAS TO BE CARRIED OUT EITHER AT THE DEALERS' OR AT THE C.I.M.A. S.p.A. AUTHORIZED WORKSHOPS, OTHERWISE ANY KIND OF WARRANTY IMMEDIATELY CEASES AND C.I.M.A. S.p.A. IS CLEARED OF ANY CONSEQUENT AND/OR IMPLIED RESPONSIBILITY.

14 INTEGRATIVE DIAGRAMS 14

14.1 - DUSTER DIAGRAM

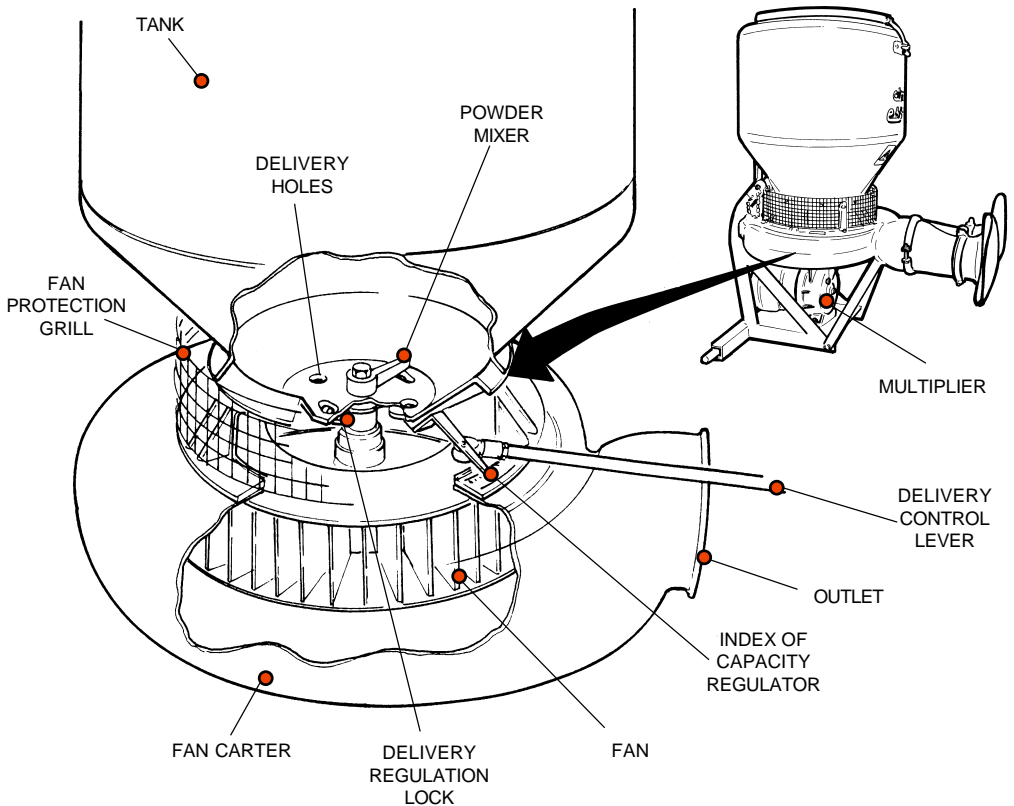

15

NOISE LEVEL

15

LqA, Observed equivalent average sound level, expressed in dB(A) = **90,2 ± 0,2**

16 ATTACHMENT: DECLARATION OF COMPLIANCE 16

CIMA®

DICHIARAZIONE DI CONFORMITÀ

ai sensi della direttiva 98/37/CE del 22/06/98 e successive modificazioni

CE

DECLARATION OF CONFORMITY

as directive: 98/37/CE - 22/06/98
and subsequent modifications

CE

DECLARATION DE CONFORMITE

selon la directive 98/37/CE - 22/06/98
et modifications ultérieures

CE

ÜBERREINSTIMMUNGS-ERKLÄRUNG

It. Direktiven 98/37/CE - 22/06/98
und nachfolgenden Änderung

CE

DECLARACION DE CONFORMIDAD

con arreglo a la Directiva 98/37/CE - 22/06/98
y modificaciones siguientes

CE

CIMA s.p.a. 27040 MONTÙ BECCARIA (PV) - ITALY - Loc. Molino Quaroni

DICHIARA
SOTTO LA PROPRIA
RESPONSABILITÀ
CHE LA MACCHINA:

HEREWITH DECLARES,
UNDER THEIR PERSONAL
RESPONSIBILITY,
THAT THE FOLLOWING
MACHINE:

DECLARONS SOUS
NOTRE RESPONSABILITE
QUE LA MACHINE
DECRITE CI-APRES:

BESTÄTIGT
HERMIT UNTER
IHRER PERSÖNLICHEN
VERBANTWORTUNG,
DAB DIE MASCHINE:

DECLARA
BAJO LA PROPIA
RESPONSABILIDA
QUE LA MAQUINA:

SERIE, TIPO - MODEL, TYPE - SERIE, TYPE - MODEL, TYP - SERIE, TIPO:

MATRICOLA - SERIAL - MATRICULE - SERIAL - MATRICULA NR.:

E' conforme ai Requisiti essenziali di Sicurezza e di Tutela della Salute di cui alla Direttiva 98/37/CE del 22/06/98 e sue successive modificazioni.

Per la verifica della Conformità di cui alle Direttive sopra menzionate, sono state consultate le seguenti:
Norme armonizzate: EN 294 EN 349 EN 907.

Conforms to the essential Safety regulation as well as the Health requirements as per European Economic Community Directive: 98/37/CE - 22/06/98 and subsequent modifications. For the verification of conformity as per above mentioned directives the following official EN norms have been consulted: Harmonized norms: EN 294 EN 349 EN 907.

Est conforme aux exigences de Sécurité et de Sauvegarde de la Santé dont à la Directive 98/37/CE - 22/06/98 et modification ultérieures.

Pour vérifier la conformité aux directives susmentionnées, ont été prises en compte les normes suivantes:
Normes harmonisées: EN 294 EN 349 EN 907.

Stimmt mit den wesentlichen Requisiten der Sicherheitsvorschriften und der Gesundheitsvorsorge lt. EWG Direktive Nr. 98/37/CE - 22/06/98 und nachfolgenden Änderungsverein. Für die Überprüfung dieser Übereinstimmungs-Erklärung lt. obigen Direktiven sind folgende Normen konsultiert worden:
Normen: EN 294 EN 349 EN 907.

Cumple con los requisitos esenciales de Seguridad y de Preservación de la Salud contenidos en la Directiva 98/37/CE - 22/06/98 y modificaciones siguientes. Para comprobar la conformidad a la que se refieren las Directivas anteriormente citadas, se han consultado las siguientes:
Normas Armonizadas: EN 294 EN 349 EN 907.

Responsabile della Sicurezza - The Security Official - Responsable Sécurité et Homologations - Der Sicherheits-Beamter - Responsable de la Seguridad

Montù Beccaria (PV)

Data, Date, Datum, Fecha, _____

Smeraldi Paolo

Smeraldi Paolo



THE OWNER AND/OR THE OPERATOR OF THE DUSTER ARE NOT PERMITTED TO MODIFY THE STRUCTURE OR THE SPECIFIC OPERATION OF THE DUSTER ITSELF. ANY REPAIRING INTERVENTION HAS TO BE CARRIED OUT EITHER AT THE DEALERS' OR AT THE C.I.M.A. S.p.A. AUTHORIZED WORKSHOPS, OTHERWISE ANY KIND OF WARRANTY IMMEDIATELY CEASES AND C.I.M.A. S.p.A. IS CLEARED OF ANY CONSEQUENT AND/OR IMPLIED RESPONSIBILITY.

17.1 - Warranty

The goods sold are covered by a general warranty that ensures the good quality of the materials, solid construction and regular operation for twelve months from the date of delivery.

During the warranty period, C.I.M.A. S.p.A. pledges to replace, free of charge, the parts which, in his unquestionable judgement, are considered defective, provided that the flaws and defects cannot be attributed to poor use or maintenance of the product or an unreasonable, inappropriate and unsuitable use of such product with respect to the technical instructions supplied by C.I.M.A. S.p.A.

The products which have been modified, repaired, assembled or tampered with by a third party, consumption materials and the parts subject to wear and tear are excluded from the warranty.

The replacements will be made free CIMA S.p.A. works and the buyer will be responsible for all shipping and return expenses.

The buyer will be responsible for the costs of the labour needed to replace the parts considered defective. The resolution of the contract and any compensation for damage cannot be claimed by the buyer except for serious faults to be proven by said buyer.

The warranty will no longer be extended to the buyer if he does not respect the agreed upon payment procedures and terms.

17.2 - Reporting defects in goods

The claims for flaws or defects in the goods shall be submitted within eight days from when such goods are received or from when hidden defects are discovered, in writing, by means of a registered letter. No claim can be made, nor as an exception, in a court of law if the goods, for which the claim is submitted, have not been regularly paid.

Any claim concerning a single delivery of goods will not exonerate the buyer from his obligation to pick-up the remaining quantity of goods within the limit of the order.

17.3 - To pass safety information

The buyer is responsible towards the final user for the safety information shown on the sale documentation, concerning use limit, performances and product features.

17.4 - Validity and acceptance

The warranty is valid if the CERTIFICATE OF WARRANTY is sent, to C.I.M.A. S.p.A., with every part of it filled in, within 30 days from the date of purchase (referring to the date of the postmark).



CERTIFICATE OF WARRANTY

Copy for the owner (to be kept in the manual "Instructions for the use and maintenance)

Last name, Name or
NAME OF THE FIRM

ADDRESS

Place PROVINCE ZIP

e.mail (*) telephone (*)

Date of purchase INVOICE N.

MACHINE MOD. MATRICULATION N.

SPRAYHEAD MOD.

Dealer's stamp (compulsory)

(*) NOT COMPULSORY DATA

PRIVACY

Consent for the personal data processing– **PROTECTION OF THE PRIVACY .**

I authorize you, according to the D.Lgs. 196/03 "Consolidated Text about the Privacy" to the processing of my personal data in observance of the law above mentioned, for the indicated purposes, and so that they can be communication to the subjects for the declared purposes.

Date Signature

Warranty conditions

1. Warranty

The goods sold are covered by a general warranty that ensures the good quality of the materials, solid construction and regular operation for twelve months from the date of delivery.

During the warranty period, C.I.M.A. S.p.A. pledges to replace, free of charge, the parts which, in his unquestionable judgement, are considered defective, provided that the flaws and defects cannot be attributed to poor use or maintenance of the product or an unreasonable, inappropriate and unsuitable use of such product with respect to the technical instructions supplied by C.I.M.A. S.p.A. The products which have been modified, repaired, assembled or tampered with by a third party, consumption materials and the parts subject to wear and tear are excluded from the warranty. The replacements will be made free CIMA S.p.A. works and the buyer will be responsible for all shipping and return expenses. The buyer will be responsible for the costs of the labour needed to replace the parts considered defective. The resolution of the contract and any compensation for damage cannot be claimed by the buyer except for serious faults to be proven by said buyer. The warranty will no longer be extended to the buyer if he does not respect the agreed upon payment procedures and terms.

2. Reporting defects in goods

The claims for flaws or defects in the goods shall be submitted within eight days from when such goods are received or from when hidden defects are discovered, in writing, by means of a registered letter.

No claim can be made, nor as an exception, in a court of law if the goods, for which the claim is submitted, have not been regularly paid.

Any claim concerning a single delivery of goods will not exonerate the buyer from his obligation to pick-up the remaining quantity of goods within the limit of the order.

3. To pass safety information

The buyer is responsible towards the final user for the safety information shown on the sale documentation, concerning use limit, performances and product features.

4. Validity and acceptance

The guarantee is valid if the CERTIFICATE OF GUARANTEE is sent, to C.I.M.A. S.p.A., with every part of it filled in, within 30 days from the date of purchase (referring to the date of the postmark).

Informative according to the D. L. n. 196 of the 2003 ("Code in matter of protection of the personal data")

Dear customer,

according to art. 13 of the D.Lgs. 196/03 "Unique Text on Privacy" (referred to as 'Law' here below) we would like to inform you about the following:

1) the personal data given to C.I.M.A. S.p.A. when filling in the "Warranty Certificate" will be processed respecting the above mentioned regulations and the rules of privacy stated there in;

2) according to art.4, paragraph 1, lett. a) of the Law, the handling of personal data signifies "whatever operation or set of operations carried out (even without the aid of electronic instruments) regarding the collection, recording, organization, conservation, research, handling, modification, selection, extracting of details, comparison of, use of, connecting to, blockage, passing on, distributing, cancellation and destruction of data, even if not recorded in a data bank";

The handling of the personal data given is carried out by automatized and non automatized instruments, with controlled access and as specified by clause B of the Law;

3) the data are processed to an institutional end, in connection with or useful to the activities of C.I.M.A. S.p.A. for filing, processing and management;

4) the data are collected and recorded so that access is only allowed to authorized persons and they may be processed exclusively by C.I.M.A. S.p.A. to the above mentioned end;

5) the collected data may only be given to a third party exclusively in connection with accounting imposed by fiscal law and in the case of demands from the judicial authority.

In addition we inform you that any interested party may exercise his rights mentioned in art.7 of the Law; in the exercise of such rights the interested party may delegate or give a proxy, in writing, to persons or associations. The authority to carry out this processing is C.I.M.A. S.p.A., represented in person by a lawyer.

The data processing is done by instruments fit to guarantee the safety and privacy as specified in clause B of the Law.



CERTIFICATE OF WARRANTY

The warranty will not be considered valid if this coupon, with every part of it filled in, is not mailed to the following address: C.I.M.A. S.p.A. - 27040 Montù Beccaria, Loc. Molino Quaroni - (PV) - Italy), or sent by fax to the following number: +39.0385.246637, within 30 days from the date of purchase.

Last name, Name or
NAME OF THE FIRM

ADDRESS

Place PROVINCE ZIP

e.mail (*) telephone (*)

Date of purchase INVOICE N.

MACHINE MOD. MATRICULATION N.

SPRAYHEAD MOD.

Dealer's stamp (compulsory)

(*) NOT COMPULSORY DATA

PRIVACY

Consent for the personal data processing – **PROTECTION OF THE PRIVACY** .

I authorize you, according to the D.Lgs. 196/03 "Consolidated Text about the Privacy" to the processing of my personal data in observance of the law above mentioned, for the indicated purposes, and so that they can be communication to the subjects for the declared purposes.

Date Signature

CUT ALONG THE DOTTED LINE

Warranty conditions

1. Warranty

The goods sold are covered by a general warranty that ensures the good quality of the materials, solid construction and regular operation for twelve months from the date of delivery.

During the warranty period, C.I.M.A. S.p.A. pledges to replace, free of charge, the parts which, in his unquestionable judgement, are considered defective, provided that the flaws and defects cannot be attributed to poor use or maintenance of the product or an unreasonable, inappropriate and unsuitable use of such product with respect to the technical instructions supplied by C.I.M.A. S.p.A. The products which have been modified, repaired, assembled or tampered with by a third party, consumption materials and the parts subject to wear and tear are excluded from the warranty. The replacements will be made free CIMA S.p.A. works and the buyer will be responsible for all shipping and return expenses. The buyer will be responsible for the costs of the labour needed to replace the parts considered defective. The resolution of the contract and any compensation for damage cannot be claimed by the buyer except for serious faults to be proven by said buyer. The warranty will no longer be extended to the buyer if he does not respect the agreed upon payment procedures and terms.

2. Reporting defects in goods

The claims for flaws or defects in the goods shall be submitted within eight days from when such goods are received or from when hidden defects are discovered, in writing, by means of a registered letter.

No claim can be made, nor as an exception, in a court of law if the goods, for which the claim is submitted, have not been regularly paid.

Any claim concerning a single delivery of goods will not exonerate the buyer from his obligation to pick-up the remaining quantity of goods within the limit of the order.

3. To pass safety information

The buyer is responsible towards the final user for the safety information shown on the sale documentation, concerning use limit, performances and product features.

4. Validity and acceptance

The guarantee is valid if the CERTIFICATE OF GUARANTEE is sent, to C.I.M.A. S.p.A., with every part of it filled in, within 30 days from the date of purchase (referring to the date of the postmark).

Informative according to the D. L. n. 196 of the 2003 (“Code in matter of protection of the personal data”)

Dear customer,

according to art. 13 of the D.Lgs. 196/03 “Unique Text on Privacy” (referred to as ‘Law’ here below) we would like to inform you about the following:

1) the personal data given to C.I.M.A. S.p.A. when filling in the “Warranty Certificate” will be processed respecting the above mentioned regulations and the rules of privacy stated there in;

2) according to art.4, paragraph 1, lett. a) of the Law, the handling of personal data signifies “whatever operation or set of operations carried out (even without the aid of electronic instruments) regarding the collection, recording, organization, conservation, research, handling, modification, selection, extracting of details, comparison of, use of, connecting to, blockage, passing on, distributing, cancellation and destruction of data, even if not recorded in a data bank”;

The handling of the personal data given is carried out by automatized and non automatized instruments, with controlled access and as specified by clause B of the Law;

3) the data are processed to an institutional end, in connection with or useful to the activities of C.I.M.A. S.p.A. for filing, processing and management;

4) the data are collected and recorded so that access is only allowed to authorized persons and they may be processed exclusively by C.I.M.A. S.p.A. to the above mentioned end;

5) the collected data may only be given to a third party exclusively in connection with accounting imposed by fiscal law and in the case of demands from the judicial authority.

In addition we inform you that any interested party may exercise his rights mentioned in art.7 of the Law; in the exercise of such rights the interested party may delegate or give a proxy, in writing, to persons or associations. The authority to carry out this processing is C.I.M.A. S.p.A., represented in person by a lawyer.

The data processing is done by instruments fit to guarantee the safety and privacy as specified in clause B of the Law.

Where we are



cima[®] S.p.A.

27040 Montù Beccaria - Loc. Molino Quaroni - (PV) - ITALIA

Tel. +39.0385.246636 r.a. - Fax +39.0385.246637

<http://www.cima.it>