

**BLITZ 42/400**

## OPERATION AND MAINTENANCE INSTRUCTIONS

**cima**® S.p.A.

27040 Montù Beccaria - Loc. Molino Quaroni - (PV) - ITALIA  
Tel. +39.0385.246636 r.a. - Fax +39.0385.246637  
<http://www.cima.it>

**cima**®

**atomizzatori e impolveratori**

Dear Customer, thank you very much!

We want to congratulate with you, for having chosen a **cima**® sprayer.

Your choice shows the wisdom of the well-informed Purchaser, aware of the fact, that the required features of quality, technique and reliability must be satisfied at the right price!

Our continuous engagement in R&D and in testing our machines allows us to realize products able to offer the best performances, a high reliability and a great easiness of use at the same time !

Our first goal, is to get our Customers happy for having met us!

The "Spare parts catalogue" of this sprayer/sprayhead is available in the "restricted area" on website [www.cima.it](http://www.cima.it).

In order to accede, use:

Username: **sprayer**

Password: **844719KE**

Where we are



**Warranty conditions****1. Warranty**

The goods sold are covered by a general warranty that ensures the good quality of the materials, solid construction and regular operation for twelve months from the date of delivery.

During the warranty period, C.I.M.A. S.p.A. pledges to replace, free of charge, the parts which, in his unquestionable judgement, are considered defective, provided that the flaws and defects cannot be attributed to poor use or maintenance of the product or an unreasonable, inappropriate and unsuitable use of such product with respect to the technical instructions supplied by C.I.M.A. S.p.A. The products which have been modified, repaired, assembled or tampered with by a third party, consumption materials and the parts subject to wear and tear are excluded from the warranty. The replacements will be made free CIMA S.p.A. works and the buyer will be responsible for all shipping and return expenses. The buyer will be responsible for the costs of the labour needed to replace the parts considered defective. The resolution of the contract and any compensation for damage cannot be claimed by the buyer except for serious faults to be proven by said buyer. The warranty will no longer be extended to the buyer if he does not respect the agreed upon payment procedures and terms.

**2. Reporting defects in goods**

The claims for flaws or defects in the goods shall be submitted within eight days from when such goods are received or from when hidden defects are discovered, in writing, by means of a registered letter.

No claim can be made, nor as an exception, in a court of law if the goods, for which the claim is submitted, have not been regularly paid.

Any claim concerning a single delivery of goods will not exonerate the buyer from his obligation to pick-up the remaining quantity of goods within the limit of the order.

**3. To pass safety information**

The buyer is responsible towards the final user for the safety information shown on the sale documentation, concerning use limit, performances and product features.

**4. Validity and acceptance**

The guarantee is valid if the CERTIFICATE OF GUARANTEE is sent, to C.I.M.A. S.p.A., with every part of it filled in, within 30 days from the date of purchase (referring to the date of the postmark).

**Informative according to the D. L. n. 196 of the 2003 ("Code in matter of protection of the personal data")**

Dear customer,  
according to art. 13 of the D.Lgs. 196/03 "Unique Text on Privacy" (referred to as 'Law' here below) we would like to inform you about the following:

1) the personal data given to C.I.M.A. S.p.A. when filling in the "Warranty Certificate" will be processed respecting the above mentioned regulations and the rules of privacy stated there in;

2) according to art.4, paragraph 1, lett. a) of the Law, the handling of personal data signifies "whatever operation or set of operations carried out (even without the aid of electronic instruments) regarding the collection, recording, organization, conservation, research, handling, modification, selection, extracting of details, comparison of, use of, connecting to, blockage, passing on, distributing, cancellation and destruction of data, even if not recorded in a data bank";

The handling of the personal data given is carried out by automatized and non automatized instruments, with controlled access and as specified by clause B of the Law;

3) the data are processed to an institutional end, in connection with or useful to the activities of C.I.M.A. S.p.A. for filing, processing and management;

4) the data are collected and recorded so that access is only allowed to authorized persons and they may be processed exclusively by C.I.M.A. S.p.A. to the above mentioned end;

5) the collected data may only be given to a third party exclusively in connection with accounting imposed by fiscal law and in the case of demands from the judicial authority.

In addition we inform you that any interested party may exercise his rights mentioned in art.7 of the Law; in the exercise of such rights the interested party may delegate or give a proxy, in writing, to persons or associations. The authority to carry out this processing is C.I.M.A. S.p.A., represented in person by a lawyer.

The data processing is done by instruments fit to guarantee the safety and privacy as specified in clause B of the Law.

# Low volume sprayers trailer-mounted models **Blitz 42/400**

Model: ..... A.T42N1.04.I11 .....

Serial Number: .....

(Publication N° LUM-BLITZ-42400-00-EN)

## OPERATION AND MAINTENANCE INSTRUCTIONS

© CIMA S.P.A. 2013 Private property.

Any reproduction, even if partial, is forbidden if not preventively authorized in writing by the Cima S.p.A. company.



CIMA S.p.A. - 27040 Montù Beccaria - Loc. Molino Quaroni - (PV) - ITALIA

Tel. +39.0385.246636 r.a. - Fax +39.0385.246637

<http://www.cima.it>



## WARRANTY CERTIFICATE

This warranty is valid only when this registration form is completed and returned, within thirty (30) days from the date of purchase, to the following address :

C.I.M.A. S.p.A. - Loc.Molino Quaroni - 27040 Montù Beccaria - (PV) - Italy  
or sent by fax to the number +39.0385.246637 or by email to: info@cima.it

Owner's Name: .....

Company Name: .....

Address: .....

City: ..... State: ..... Postcode: .....

Email: ..... Tel. No: .....

Date of Purchase: ..... Invoice No: .....

Machine Model: ..... Serial No: .....

Sprayhead Model: .....

Authorized Dealer's Stamp (compulsory)

## PRIVACY

### Consent to the use of personal data

"In compliance with the Italian legislative Decree no. 196 dated 30/06/2003, I hereby authorize C.I.M.A. S.p.A. to use and process my personal details contained in this document."

Date ..... Signature .....

cut along the dotted line

**Warranty conditions**

**1. Warranty**

The goods sold are covered by a general warranty that ensures the good quality of the materials, solid construction and regular operation for twelve months from the date of delivery. During the warranty period, C.I.M.A. S.p.A. pledges to replace, free of charge, the parts which, in his unquestionable judgement, are considered defective, provided that the flaws and defects cannot be attributed to poor use or maintenance of the product or an unreasonable, inappropriate and unsuitable use of such product with respect to the technical instructions supplied by C.I.M.A. S.p.A. The products which have been modified, repaired, assembled or tampered with by a third party, consumption materials and the parts subject to wear and tear are excluded from the warranty. The replacements will be made free CIMA S.p.A. works and the buyer will be responsible for all shipping and return expenses. The buyer will be responsible for the costs of the labour needed to replace the parts considered defective. The resolution of the contract and any compensation for damage cannot be claimed by the buyer except for serious faults to be proven by said buyer. The warranty will no longer be extended to the buyer if he does not respect the agreed upon payment procedures and terms.

**2. Reporting defects in goods**

The claims for flaws or defects in the goods shall be submitted within eight days from when such goods are received or from when hidden defects are discovered, in writing, by means of a registered letter. No claim can be made, nor as an exception, in a court of law if the goods, for which the claim is submitted, have not been regularly paid. Any claim concerning a single delivery of goods will not exonerate the buyer from his obligation to pick-up the remaining quantity of goods within the limit of the order.

**3. To pass safety information**

The buyer is responsible towards the final user for the safety information shown on the sale documentation, concerning use limit, performances and product features.

**4. Validity and acceptance**

The guarantee is valid if the CERTIFICATE OF GUARANTEE is sent, to C.I.M.A. S.p.A., with every part of it filled in, within 30 days from the date of purchase (referring to the date of the postmark).

**Informative according to the D. L. n. 196 of the 2003 ("Code in matter of protection of the personal data")**

Dear customer, according to art. 13 of the D.Lgs. 196/03 "Unique Text on Privacy" (referred to as 'Law' here below) we would like to inform you about the following:

- 1) the personal data given to C.I.M.A. S.p.A. when filling in the "Warranty Certificate" will be processed respecting the above mentioned regulations and the rules of privacy stated there in;
- 2) according to art.4, paragraph 1, lett. a) of the Law, the handling of personal data signifies "whatever operation or set of operations carried out (even without the aid of electronic instruments) regarding the collection, recording, organization, conservation, research, handling, modification, selection, extracting of details, comparison of, use of, connecting to, blockage, passing on, distributing, cancellation and destruction of data, even if not recorded in a data bank";
- The handling of the personal data given is carried out by automatized and non automatized instruments, with controlled access and as specified by clause B of the Law;
- 3) the data are processed to an institutional end, in connection with or useful to the activities of C.I.M.A. S.p.A. for filing, processing and management;
- 4) the data are collected and recorded so that access is only allowed to authorized persons and they may be processed exclusively by C.I.M.A. S.p.A. to the above mentioned end;
- 5) the collected data may only be given to a third party exclusively in connection with accounting imposed by fiscal law and in the case of demands from the judicial authority.

In addition we inform you that any interested party may exercise his rights mentioned in art.7 of the Law; in the exercise of such rights the interested party may delegate or give a proxy, in writing, to persons or associations. The authority to carry out this processing is C.I.M.A. S.p.A., represented in person by a lawyer.

The data processing is done by instruments fit to guarantee the safety and privacy as specified in clause B of the Law.

**LISTING OF VALID PAGES**

This publication consists of 55 pages, subdivided as follows:

| N° OF PAGE   | REVISION | BASE     |
|--------------|----------|----------|
| from I to VI | 00       | May 2013 |
| from 1 to 49 | 00       | May 2013 |

**ADDITIONAL RECORDS AND VARIANTS**

| REVISION | DESCRIPTION             |
|----------|-------------------------|
| 00       | First Edition, May 2013 |
| 01       |                         |
| 02       |                         |
| 03       |                         |
| 04       |                         |
| 05       |                         |
| 06       |                         |
| 07       |                         |
| 08       |                         |

## GENERAL INDEX

|          |   |    |
|----------|---|----|
| <b>1</b> | <b>FOREWORD</b> .....   | 1  |
| 1.1      | CHECKS TO BE CARRIED OUT AT MATERIAL RECEPTION .....          | 1  |
| 1.2      | PUBLICATION IDENTIFICATION .....                              | 1  |
| 1.3      | ATTACHED PUBLICATIONS .....                                   | 1  |
| 1.4      | PURPOSE OF PUBLICATION .....                                  | 1  |
| 1.5      | REFERENCE TO REGULATIONS .....                                | 2  |
| 1.6      | USING THE MANUAL .....  | 2  |
| 1.7      | UPDATES .....   | 2  |
| <b>2</b> | <b>GLOSSARY</b> .....   | 3  |
| 2.1      | TERMINOLOGY .....   | 3  |
| 2.2      | ABBREVIATIONS .....   | 3  |
| 2.3      | DECALS .....  | 3  |
| <b>3</b> | <b>GENERAL INFORMATION</b> .....                              | 6  |
| 3.1      | MACHINE IDENTIFICATION .....                                  | 6  |
| 3.2      | TECHNICAL ASSISTANCE .....                                    | 6  |
| 3.3      | SAFETY NOTICES .....  | 7  |
| 3.3.1    | General .....   | 7  |
| 3.3.2    | Precautions against the fires .....                           | 8  |
| 3.4      | SAFETY SYSTEMS .....  | 8  |
| 3.5      | HANDLING OF AGRO-CHEMICALS .....                              | 9  |
| 3.5.1    | Storage .....   | 9  |
| 3.5.2    | Specific equipment .....                                      | 9  |
| 3.5.3    | Disposal of empty containers and agro-chemical residues ..... | 10 |
| 3.5.4    | Personal Protective Equipment (PPE) .....                     | 10 |
| <b>4</b> | <b>MACHINE'S STRUCTURAL ANALYSIS</b> .....                    | 12 |
| 4.1      | FRAME WITH DRAWBAR .....                                      | 13 |
| 4.2      | FAN SERVO AMPLIFIER .....                                     | 15 |
| 4.3      | HYDRAULIC CIRCUIT .....                                       | 16 |
| 4.3.1    | Operating principle .....                                     | 16 |
| 4.3.2    | Hydraulic circuit components .....                            | 16 |
| 4.4      | TECHNICAL DATA .....  | 21 |
| 4.4.1    | Sprayers dimensions and weights .....                         | 21 |
| 4.4.2    | Accessories weight .....                                      | 22 |
| 4.4.3    | Centrifugal pump CD 32 .....                                  | 22 |
| 4.4.4    | Filters .....   | 22 |
| 4.4.5    | Tanks .....   | 22 |
| 4.4.6    | Fan .....   | 22 |

## WARRANTY CERTIFICATE

Copy for the owner (to be kept in the manual "Operation and maintenance instructions").

Owner's Name: .....

Company Name: .....

Address: .....

City: ..... State: ..... Postcode: .....

Email: ..... Tel. No: .....

Date of Purchase: ..... Invoice No: .....

Machine Model: ..... Serial No: .....

Sprayhead Model: .....

Authorized Dealer's Stamp (compulsory)

## PRIVACY

### Consent to the use of personal data

"In compliance with the Italian legislative Decree no. 196 dated 30/06/2003, I hereby authorize C.I.MA. S.p.A. to use and process my personal details contained in this document."

Date ..... Signature .....



|      |                                  |    |
|------|----------------------------------|----|
| 15   | NOISE LEVEL .....                | 48 |
| 16   | WARRANTY .....                   | 49 |
| 16.1 | GENERAL INFORMATION .....        | 49 |
| 16.2 | REPORTING DEFECTS IN GOODS ..... | 49 |
| 16.3 | TO PASS SAFETY INFORMATION ..... | 49 |
| 16.4 | VALIDITY AND ACCEPTANCE .....    | 49 |



**THE OWNER AND/OR THE OPERATOR OF THE SPRAYER ARE NOT PERMITTED TO MODIFY THE STRUCTURE OR THE SPECIFIC OPERATION OF THE SPRAYER ITSELF. ANY REPAIRING INTERVENTION HAS TO BE CARRIED OUT EITHER AT THE DEALERS' OR AT THE C.I.M.A. S.p.A. AUTHORIZED WORKSHOPS, OTHERWISE ANY KIND OF WARRANTY IMMEDIATELY CEASES AND C.I.M.A. S.p.A. IS CLEARED OF ANY CONSEQUENT AND/OR IMPLIED RESPONSIBILITY.**

### 16.1 - General information

The goods sold are covered by a general warranty that ensures the good quality of the materials, solid construction and regular operation for twelve months from the date of delivery.

During the warranty period, C.I.M.A. S.p.A. pledges to replace, free of charge, the parts which, in his unquestionable judgement, are considered defective, provided that the flaws and defects cannot be attributed to poor use or maintenance of the product or an unreasonable, inappropriate and unsuitable use of such product with respect to the technical instructions supplied by C.I.M.A. S.p.A.

The products which have been modified, repaired, assembled or tampered with by a third party, consumption materials and the parts subject to wear and tear are excluded from the warranty.

The replacements will be made free CIMA S.p.A. works and the buyer will be responsible for all shipping and return expenses.

The buyer will be responsible for the costs of the labour needed to replace the parts considered defective. The resolution of the contract and any compensation for damage cannot be claimed by the buyer except for serious faults to be proven by said buyer.

The warranty will no longer be extended to the buyer if he does not respect the agreed upon payment procedures and terms.

### 16.2 - Reporting defects in goods

The claims for flaws or defects in the goods shall be submitted within eight days from when such goods are received or from when hidden defects are discovered, in writing, by means of a registered letter. No claim can be made, nor as an exception, in a court of law if the goods, for which the claim is submitted, have not been regularly paid.

Any claim concerning a single delivery of goods will not exonerate the buyer from his obligation to pick-up the remaining quantity of goods within the limit of the order.

### 16.3 - To pass safety information

The buyer is responsible towards the final user for the safety information shown on the sale documentation, concerning use limit, performances and product features.

### 16.4 - Validity and acceptance

The guarantee is valid if the CERTIFICATE OF GUARANTEE is sent, to C.I.M.A. S.p.A., with every part of it filled in, within 30 days from the date of purchase (referring to the date of the postmark).



Aerial noise emitted  
Lq A ..... 92,0 ±0,2 dB(A)

## 1.1 - CHECKS TO BE CARRIED OUT AT MATERIAL RECEPTION

At reception of the machine, make sure that this one is complete and in good condition in every part. If any damaged parts are found out, timely inform about that the machine Distributor, or directly contact C.I.M.A. SpA.

Upon receipt of the machine, expressly verify the following conditions:

- that the machine is delivered assembled in all its parts, and that the equipment fully complies with the requested configuration (that procedure is necessary, because for overall dimensions' requirements the machine is often partially disassembled during the transport);
- that the connections are correctly mounted;
- that the cable clamps are correctly tightened, as well as all the fittings and connections;
- that all the protections are both present and firmly fastened;
- that the fan, the fan protection casing or other parts of the machine ARE NOT damaged because of any bumps suffered during the transport.

## 1.2 - PUBLICATION IDENTIFICATION

The "OPERATION AND MAINTENANCE INSTRUCTIONS" manual is an integrative part of the sprayers.

It is identified by a Publication No. located on the frontispiece, and through which the document can be identified, traced and/or subsequently referred to.

The information elements contained herein are updated as at the date of publication. C.I.M.A. S.p.A. reserves the right to modify its machines without notice, with the purpose of applying technical enhancements, and it declines all responsibility for possible omissions from the publication.

All rights are reserved. No parts of this book may be reproduced or utilized in any form or by any means, electronic or mechanical, including photocopying, recording, or by any information storage and retrieval system, without permission in writing by C.I.M.A. S.p.A.

## 1.3 - ATTACHED PUBLICATIONS

- Spare parts catalogue;
- Distribution devices, "Operation and maintenance instruction";
- Distribution devices, "Spare parts catalogue"
- "Low Volume - Instructions for sprayer adjustment".

## 1.4 - PURPOSE OF PUBLICATION

All indications contained in this manual are aimed at the user of the sprayer.

The duration of the machine and its operation, the operator's safety and the respect for the environment are dependent upon scrupulous observance of the stated norms.

Before making use of the sprayer, the user must read, understand and abide by all regulations listed in this manual.

## 1.5 - REFERENCE TO REGULATIONS

This manual was set out conforming to the regulations contained in following documents:

- Directive 2006/42/CE: Attachment 1 point 1.7.4;
- UNI 10653: Technical Documentation;
- UNI 10893: Technical Documentation.

## 1.6 - USING THE MANUAL

Read every part of this manual, paying attention to the **WARNING** and **DANGER** indications both on the text and on the machine or on components.

All operations suggested by the manual will have to be followed with the utmost care and only after having understood the negative consequences of improper usage.

The following “**symbols**” are used within the text in order to highlight and visually identify the importance of the various types of information:



Indicates important additional information.



Non observance can result in permanent damage to the sprayer.



Highlights possibly dangerous situations to people.

The manual, with relevant attachments and possible integrating issues, must be kept with the utmost care and must always be complete, integer and legible in every part. Should it be mislaid it is imperative to immediately request a duplicate from C.I.M.A. S.p.A. Should the decals originally applied on the machine be mislaid, damaged or become incomprehensible, they should be promptly replaced.

For every type of distribution device (Head) delivered with the sprayer, a specific user and maintenance manual is attached. All the head manuals must always accompany the one of the machine.



- The manual must always be kept for the sprayer's whole operational life.
- Any modification received must be permanently inserted in this publication.
- The manual must be ceded with the sprayer should this be sold.

## 1.7 - UPDATES

Possible updates that C.I.M.A. S.p.A. will provide the owner of the sprayer will be accompanied by instructions to insert in this publication.

Should the machine be sold, the owner must inform the new purchaser that he should notify C.I.M.A. S.p.A. of his address in order to receive possible future integrating issues and/or updates.

## 14.6 - TANK REMOVAL OR REPLACEMENT



This operation has to be carried out by a **C.I.M.A. service point**



The operation has to be carried out by complete absence of liquid residuals both inside the tank and in the hydraulic circuit.

1. Make the tank free from all the hydraulic and pneumatic connections.
2. Using an wrecking bar release the four projections (2) that lock the tank (1).
3. Lift the tank and remove it from the frame.



Before reassembling the main tank check the integrity of the projections (2) and the tank support surface.

4. Position the tank on the frame; ensure the correct positioning of the projections.
5. Connect the hydraulic and pneumatic connections.

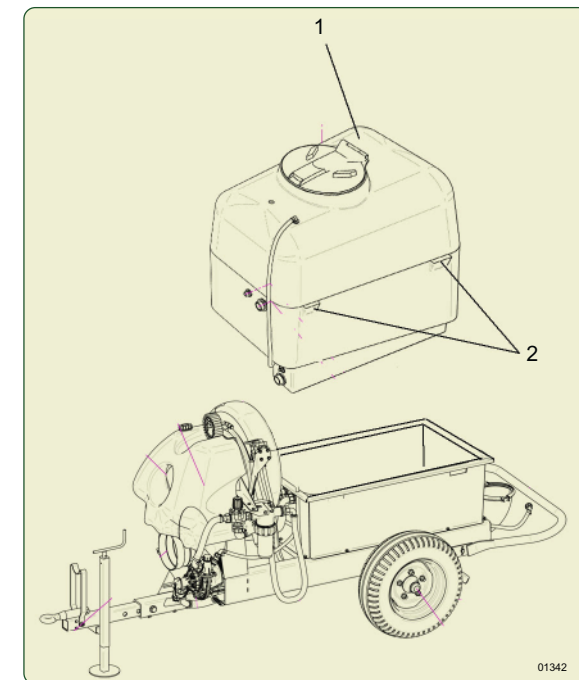

## 14.5. - CHECK HYDRAULIC DELIVERY



**TESTING OF HYDRAULIC DELIVERY MUST BE MADE WITH THE SPRAYER ON A FLAT SURFACE. THE PROOF IS IN THE DETECTION OF TIME TO PROVIDE A KNOWN QUANTITY CONTENT OF LIQUID IN TANK**

1. Close the taps of the 2-way manual distributor: the levers are to be lowered (horizontally positioned);
2. Fill the tank with about 250 liters of clean water (**USED AS REFERENCE THE MARK OF LEVEL INDICATOR ON THE TANK** - see Paragraphs 8.2/8.3).



**The claimed performance is obtained with the PTO at 540 rpm. and with the fan running .  
For correct verification result this condition MUST ALWAYS BE RESPECTED.**

3. Bring the PTO to 540 rpm rotation rate.
4. Open the taps of the 2-way manual distributor: the levers are to be raised (vertically positioned);
5. Regulate the operating pressure, by acting on the pressure regulator (P5) and regulate the position of calibration disc (P11) in accord to "Delivery chart" relating to the sprayhead used.
6. Close the taps of the 2-way manual distributor: the levers are to be lowered (horizontally positioned);
7. Add water to the tank until you reach the mark of 300 liters (reference).
8. Add additional 25 liters of water to the tank, the quantity required for the verification flow, using a graduated container or by weighing the amount payable (1liter = 1 kg).
9. Open the taps of the 2-way manual distributor to start delivery.
10. Continue the delivery until the water reaches the mark 300 liters on the level indicator.



**NOTED THE TIME ELAPSED BETWEEN THE RELEASE DELIVERY AND THE ACHIEVEMENT OF MARK 300 LITERS.**

11. Apply the formula:  $Q = \left( \frac{60}{t} \right) \times 25$  where: **Q**, is the hourly delivery detected (lt./h);  
**t**, is the time measured in minutes and seconds (centesimal)

**TESTING IS CONSIDERED WITH POSITIVE RESULTS (machine properly calibrated) WHEN THE VALUE CALCULATED "Q" IS INDICATED ON THE "DELIVERY CHART" WITH A TOLERANCE OF ± 2.5%.**

In case of different values to verify the efficiency of the pipe, the fittings, the pressure gauge and the proper positioning of the calibration discs (P11), if necessary replace the damaged or defective, and the test repeated.

### 2.1 - TERMINOLOGY

The terms FRONT, REAR, RIGHT and LEFT utilized in this publication refer to the sprayer as seen by an operator from behind the operative unit along the drive line and facing it: **the rear part** of the machine is that closest to the operator, and is where the distribution device (Head) is mounted - and **the front part** is the one that gets attached to the tractor.

### 2.2 - ABBREVIATIONS

|                    |       |  |
|--------------------|-------|--|
| cm                 | ..... | centimeter                                   |
| g                  | ..... | grams  |
| h                  | ..... | hour   |
| ha                 | ..... | hectare                                      |
| ha/h               | ..... | hectares per hour                            |
| l                  | ..... | litre  |
| l/h                | ..... | litres per hour                              |
| l/min.             | ..... | litres per minute                            |
| kg                 | ..... | kilogram                                     |
| kg/cm <sup>2</sup> | ..... | kilograms per square centimetre (atmosphere) |
| km                 | ..... | kilometre                                    |
| km/h               | ..... | kilometres per hour                          |
| Lm                 | ..... | width in metres                              |
| m                  | ..... | metre  |
| Mesh               | ..... | N° of meshes per liner inch                  |
| Micron             | ..... | 1/1000 of millimetre                         |
| mm                 | ..... | millimetre                                   |
| PTO                | ..... | Power take-off                               |
| RPM                | ..... | revs per minute                              |
| s                  | ..... | second                                       |

### 2.3 - DECALS

The safety and use/maintenance decals are applied to the machine are described in the following paragraph.



**Every decal is marked with its part number, in case it needs to be replaced.**

The arrangement of the adhesives on the machine is shown in the following pictures.

Safety decals



95001

- STOP THE ENGINE AND REMOVE THE KEY FROM THE TRACTOR'S CONTROL PANEL BEFORE CARRYING OUT ALL MAINTENANCE OR REPAIR OPERATIONS
- CONSULT THE USER AND MAINTENANCE MANUAL BEFORE USING OR INTERVENING ON THE MACHINE



95098

- CONSULT THE USER AND MAINTENANCE MANUAL BEFORE USING THE MACHINE
- DANGER OF CONTAMINATION BY CONTACT OR POISONOUS PRODUCTS INHALATION
- IT IS FORBIDDEN TO ENTER INTO THE TANK!



95005

- DANGER, PARTS IN MOTION. BEFORE REMOVING PROTECTION GUARDS, STOP THE TRACTOR, REMOVE THE KEY FROM THE TRACTOR'S CONTROL PANEL AND ENSURE THAT ALL MOVING PARTS HAVE STOPPED



95007

- DANGER OF SPRAYS: KEEP AT A SAFE DISTANCE



95008

- NO HAND-WASHING TANK



95010

- MAXIMUM OPERATING SPEED OF THE DRIVE OUTLET (PTO): 540 RPM



95009

- DANGER: GLOVES MUST BE USED TO EMPTY THE TANK

Use and maintenance decals



95065

- WARNING: NEVER OPERATE THE SPRAYER WITHOUT LIQUID IN THE TANK



95054

- GREASE EVERY 200 HOURS: FAN BELT-TENSIONER SUPPORT



95007

- HAND WASHING TANK TAP  
Imprint next to the tap

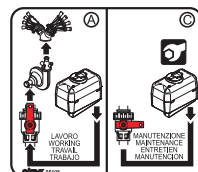

95108

- INDICATION ON THE OPERATION OF THE TAP (P2)

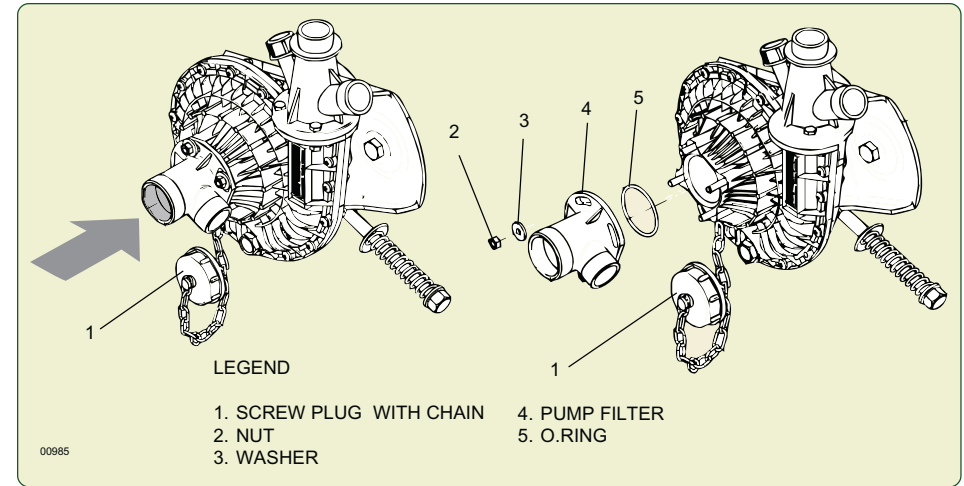

14.4 - TANK LEVEL GAUGE CLEANING

1. With a suitable pliers release the clamp (3 and 4) fixing transparent tube (1) of the level gauge.
2. Take off and remove the transparent tube (1).
3. Remove the red plastic ball (3).
4. Clean, with clean water, the transparent tube both in and outside.



- Gather the rinsing water in a proper container provided to be waste according to the rules or used again, putting it in the tank, for a next treatment if suitable with the product to be used.

5. If the cleaning is not satisfactory, replace the transparent tube (1).



- Waste the transparent tube according to the same method as per the pesticides container.

6. Put the red plastic ball (2) into the transparent tube (1).
7. Install the transparent tube (1) making slip it on the rubber fittings.
8. Place the clamps (3 and 4) fixing the transparent tube (1) of the level gauge and close them with a suitable pliers.

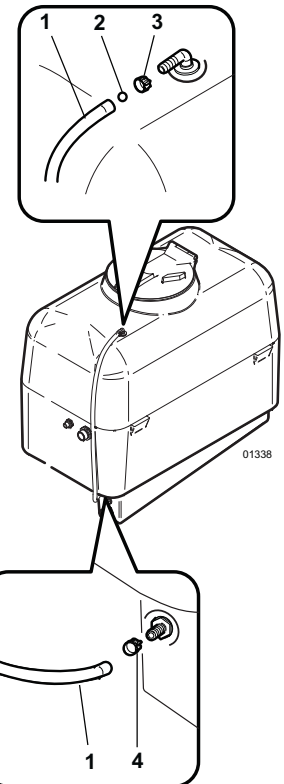

01338

## 14.2. - PRESSURE GAUGE REPLACEMENT

1. Unscrew and remove the fixing screws of the hand-washing tank (1).
2. Distance the hand-washing tank just enough to unscrew and decouple the pipi-holder (2) from the connection of the pressure gauge (4).
3. Remove the hand-washing tank (1).
2. Unscrew the ring nut (3) and remove the gauge (4).
3. Replace the faulty pressure gauge (4).
4. Mount the new pressure gauge (4) on the hand-washing tank (1) and later install the hand-washing tank (1), by carrying out in reverse order the step mentioned for its removal.

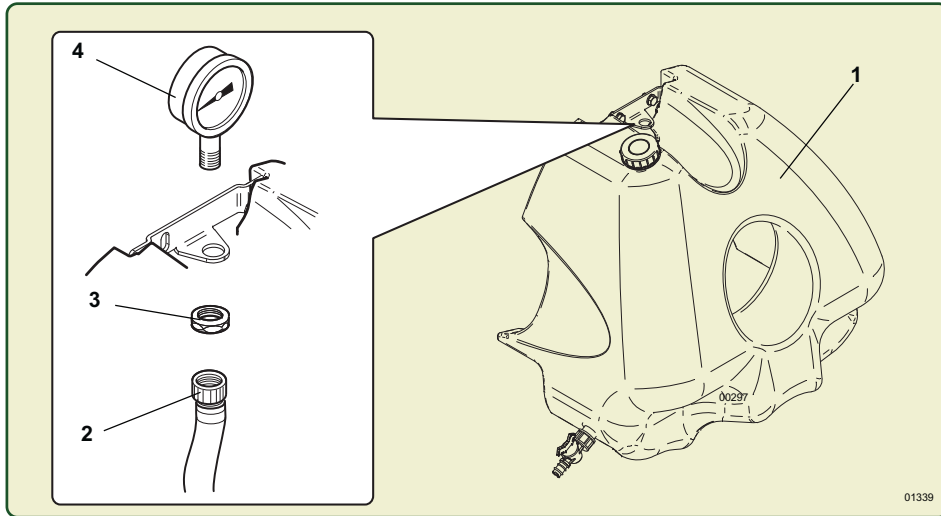

 ANY OTHER INTERVENTION HAS TO BE CARRIED OUT AT A C.I.M.A. CUSTOMERS' SERVICING CENTER.

## 14.3 - INSPECTION AND CLEANING PUMP FILTER

 The pump is provided by the suction side of a filter to prevent the accidental entry of foreign bodies in the pump body, such a possibility does not constitute a hazard and can only cause damage to the impeller shown by a drop in pressure reported by gauge..

The clogging of the filter pump causing an immediate lowering of pressure delivery. If necessary check the cleanliness of the filter:

1. Position the lever of the cock (P2) in position "C".
2. Unscrew the plug (1) and eventually remove the foreign body present in to the filter.
3. If necessary, unscrew the nuts (2) and remove the filter (4), to clean completely.
4. Replace the filter by paying attention to the conditions and the proper placement of the O.Ring (5).
5. Close the screw plug (1).
6. Position the lever of the cock (P2) in position "A" - **WORKING**".

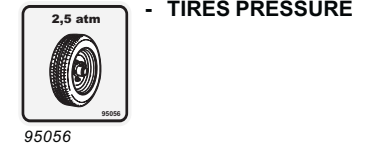
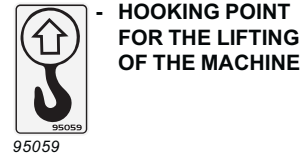

## Positioning of the safety, use and maintenance decals

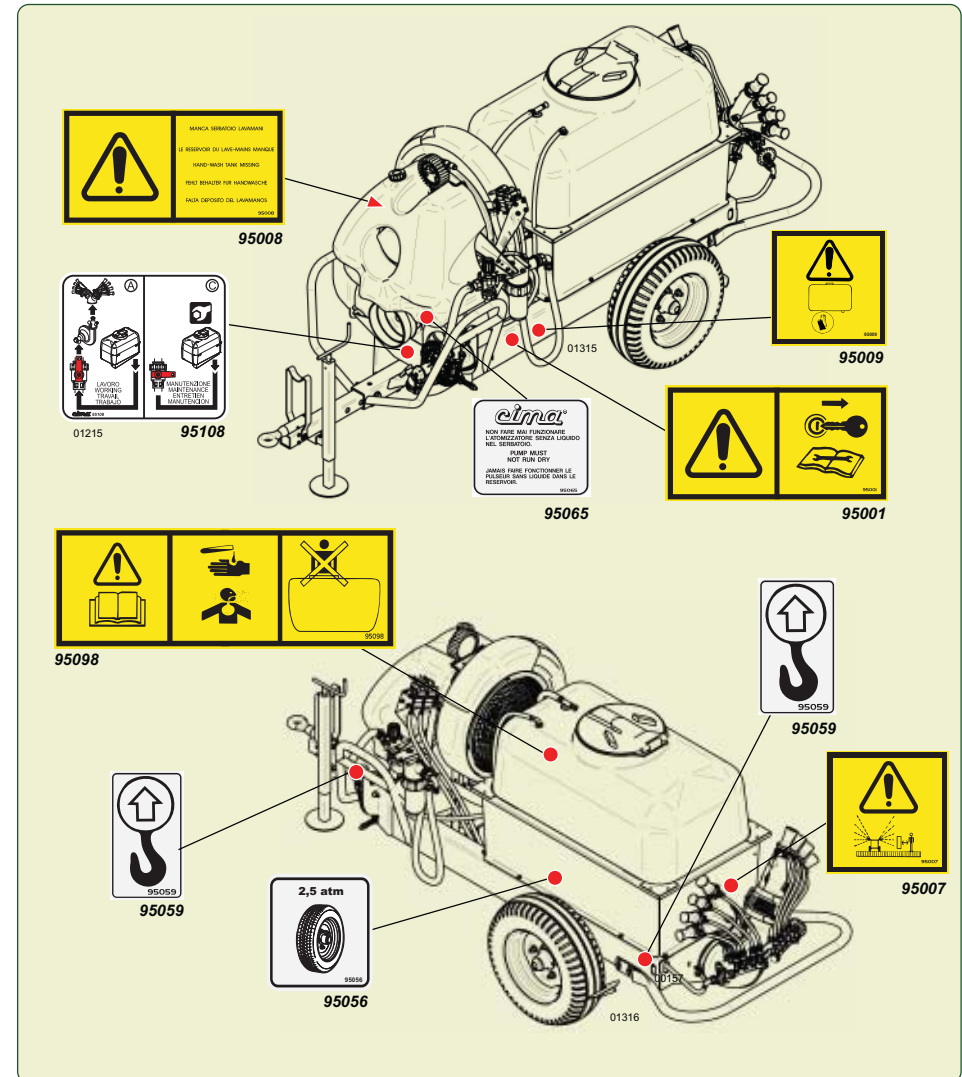

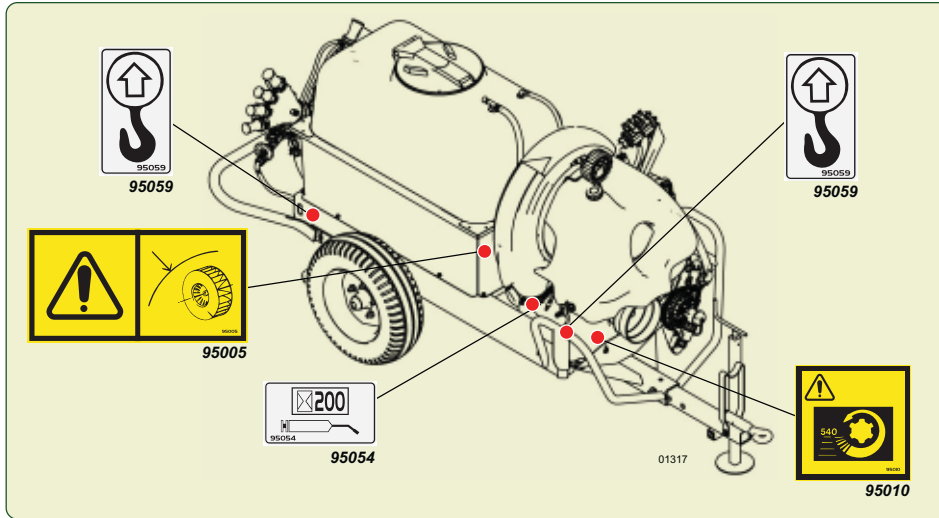

### 3 GENERAL INFORMATION 3

#### 3.1 - MACHINE IDENTIFICATION

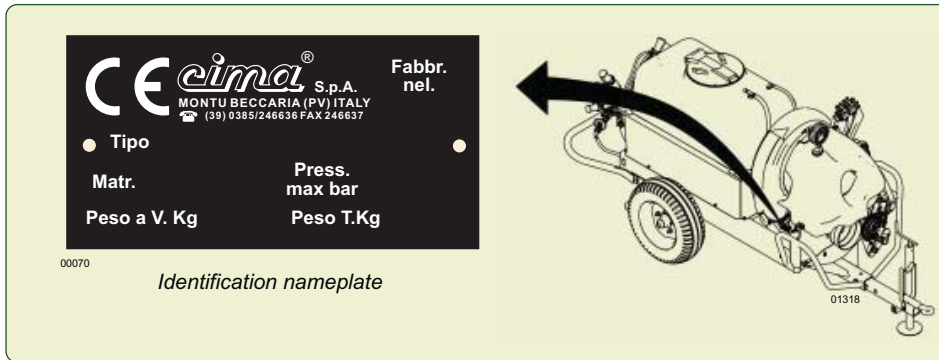

#### 3.2 - TECHNICAL ASSISTANCE

C.I.M.A. S.p.A. is at the complete disposal of customers for any type of intervention. The names and addresses of its service network, both in Italy and in foreign countries, can be requested from:

**C.I.M.A. S.p.A. - 27040 Montù Beccaria - Loc. Molino Quaroni (PV) - ITALIA**  
 tel. +39-0385-246636 - fax +39-0385-246637  
 e.mail service@cima.it

### 14 REPAIRS ALLOWED 14

**⚠ THE OWNER AND/OR THE OPERATOR OF THE SPRAYER ARE NOT PERMITTED TO MODIFY THE STRUCTURE OR THE SPECIFIC OPERATION OF THE SPRAYER ITSELF. ANY REPAIRING INTERVENTION HAS TO BE CARRIED OUT EITHER AT THE DEALERS' OR AT THE C.I.M.A. S.p.A. AUTHORIZED WORKSHOPS, OTHERWISE ANY KIND OF WARRANTY IMMEDIATELY CEASES AND C.I.M.A. S.p.A. IS CLEARED OF ANY CONSEQUENT AND/OR IMPLIED RESPONSIBILITY.**

**⚠ ⏸ Stop the engine and remove the key from the tractor's control panel before any operation on the sprayer.**

#### 14.1 - REPLACEMENT OF PUMP CONTROL BELT

1. Remove hands-washing tank.
2. Remove the fan assembly protection, by unscrewing the screw fastening it to the frame.
3. Completely unscrew the tightener spring adjusting screw: the pump support plate will so freely turn.
4. Remove the worn out belt, by getting it first loose from the pump pulley and then from the upper control pulley.
5. Insert the belt first into the race of the upper pulley and then into the race of the pump pulley.
6. Reinstall the spring of the belt-tensioner according to the suggested tensioning conditions.
7. Mount back the fan assembly protection casing.
8. Install hands-washing tank.

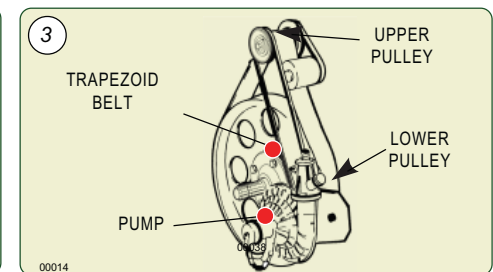
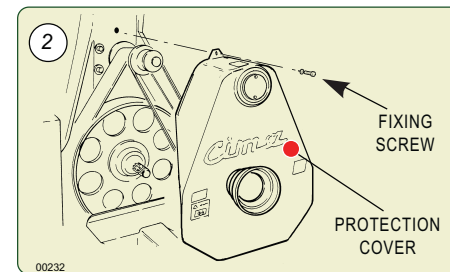
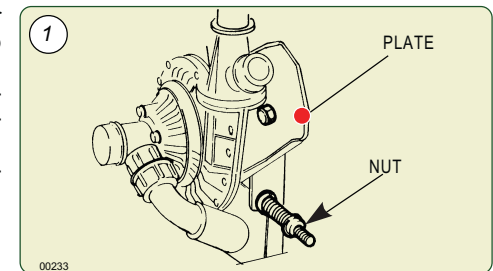

**👉 Carefully tighten the screws that were undone during the belt replacement.**

**E. FAULT: Anomalous and continuous noisiness together with vibrations of the fan group.**

1. CAUSE: Breaking of the fan shaft bearings.  
**REMEDY:** Address a C.I.M.A. point of "Sale and Service".
2. CAUSE: Interference fan - case (result of an accidental collision).  
**REMEDY:** Address a C.I.M.A. point of "Sale and Service".

**F. FAULT: Intermittent operation of the whole distribution device**

1. CAUSE: Lack of seal of the hydraulic circuit that goes from the tank (T1) suction pipes to the electrovalves (E7) or hand distributor (P8).  
**REMEDY:** Carefully inspect all the points at which suction of air can take place, including as well those at which no liquid seepage is detected. Check the proper tightening of ring nuts, fittings and clamps. Check the efficiency of the sealers and the integrity of the piping. Reinstate the efficiency and replace parts that might have been found to be defective.

**G. FAULT: Intermittent spraying only on the one side of the distribution device**

1. CAUSE: Faulty sealing of the hydraulic circuit going from the manual (P8) or electrical (E7) distributor to the distribution point involved.  
**REMEDY:** As per point F.1.

**H. FAULT: No spraying action delivered: totally.**

1. CAUSE: Clogging up of the grill/filter on the pump, of the pump suction inside the tank or suction pipes of pump clogged up with deposits of hardened plant protection product.  
**REMEDY:** Clean.

**I. FAULT: No spraying action delivered: totally or only on the one side of the distribution device**

1. CAUSE: Manual distributor (P8) taps dirty or clogged, or pump suction piping clogged by hardened product deposits.  
**REMEDY:** Clean.
2. CAUSE: Pump defective (only in case total delivery missing).  
**REMEDY:** Address a C.I.M.A. point of "Sale and Service".
3. CAUSE: Broken pump belt.  
**REMEDY:** Replace the belt.



**THE CAUSES AND REMEDIES FOR THE FAULTS CONCERNING THE DELIVERY OF THE SPRAYING BY ONE OR MORE DIFFUSERS ARE INDICATED IN THE USE AND MAINTENANCE MANUAL OF EACH SPRAYHEAD.**

**J. FAULT: Anomalous consumption of oil of the fan support.**

1. CAUSE: Oil drain plug not adequately closed.  
**REMEDY:** Check, reposition and adequately close then handle the filling up of the oil level.
2. CAUSE: Damaged flexible oil waste pipe or damaged pipe fixing clamp.  
**REMEDY:** Check, adequately then handle the filling up of the oil level. Replace the damaged parts: Address a C.I.M.A. point of "Sale and Service".
3. CAUSE: Drawings from the support mechanical seals.  
**REMEDY:** Address a C.I.M.A. point of "Sale and Service".

**M. FAULT: Noisiness (ticking) coming from the lower part of the mechanical drive at low runnings, above all when slowing down.**

1. CAUSE: Lack of grease in the multiplier overrunning clutch.  
**REMEDY:** Grease the overrunning clutch.

## 3.3 - SAFETY NOTICES

### 3.3.1 - General



The personnel appointed to the use of the machine must have acquired an exhaustive knowledge of the same one and of the dispositions contained inside this publication, be able to properly interpret the symbols of the adhesives applied on the machine, and, in addition, perfectly know the safety and the work hygienic rules in force in the country where the machine itself is to be used.

All the preparation, use, maintenance, moving and transporting operations must be carried out of the regulations contained in this publication.



**IT IS FORBIDDEN TO UTILIZE THE SPRAYER FOR PURPOSES OTHER THAN FOR ITS INTENDED USE, SINCE IT WAS MANUFACTURED ONLY FOR SPRAYING AGRICULTURAL CROPS WITH ANTI-PARASITIC PRODUCTS.**

It is necessary to scrupulously abide by the following general norms:

- check that the weight and power of the tractor are compatible with the sprayer to be used;
- verify that the tow capacity of the tractor is compatible with the total weight of the sprayer to be used;



**On the identification plate, the full-load weight (PESO T.) of the machine is indicated, measured WITHOUT the distribution device, and WITHOUT the accessories possibly installed.**

**In order to calculate the towed weight in operative conditions (at full load), add to the weight indicated on the identification plate (PESO T.), the weight of the distribution device which is used (see "Distribution devices – Use instructions" manual) and the weight of the installed accessories (Par. 4.4.2 - Weight of the accessoires).**

- before utilisation, check the correct tightening and securing of the machine's various components, paying particular attention to the safety protections and to the moving parts;
- only utilize protected cardan shafts.  
Carry out the assembly only if the drive outlets of both tractor and sprayer are equipped with the protection counter-guard;
- check that the cardan shaft is blocked by the appropriate anti-rotation chains;
- keep people and animals away from the machine before starting it up;
- don't wear articles of clothing that might get caught in moving parts;
- keep to a low speed while negotiating bumps or crossing ditches.
- during the use of the machine, the operator must have a sufficiently good visibility on the working areas, consequently it is recommended to keep both clean and efficient the cab windows and the rear-view mirrors;
- actuate the parking brake when the tractor is stopped on a slope;
- always stop the tractor's engine and actuate the parking brake before carrying out any operation on the sprayer;
- never leave the machine unguarded, when the key is inserted inside the tractor control panel.



- **All maintenance and repair operations must be carried out only after having rinsed the tank and flushed the system.**
- **Before operating within the tank it is necessary to wash it thoroughly with clean water.**
- **The application of paints and/or solvents, the washing of closed environments and machinery as well as the utilisation of the air flow for purposes other than those expressly concerning the spraying of agro-chemicals is not permitted.**
- **It is forbidden to enter the tank.**

### 3.3.2 - Precautions against the fires

Don't approach either flames or heat sources to the machines. The materials used for manufacturing the machine itself are made by widely using oil derivatives: tanks, pipes, wheels, plastic components; besides, the presence of lubricants and of chemical product residuals make them potentially flammable.



- It is forbidden to perform welding operations if ammonium salts were previously used.
- It is forbidden to use the machine within a potentially explosive environment.

### 3.4 - SAFETY SYSTEMS

All machine moving parts are suitably protected by guards and highlighted through the use of warning decals.



- It is forbidden to use the machine with these guards removed.
- Before removing the protection, stop the tractor's engine and remove the key from the control panel.

The pictures illustrate the machine's guarded parts:

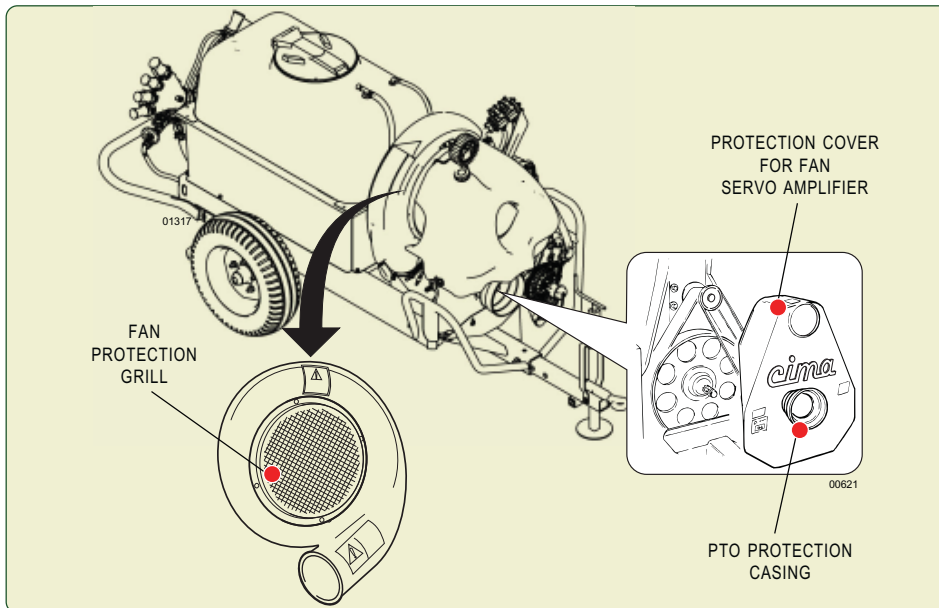

**THE OWNER AND/OR THE OPERATOR OF THE SPRAYER ARE NOT PERMITTED TO MODIFY THE STRUCTURE OR THE SPECIFIC OPERATION OF THE SPRAYER ITSELF. ANY REPAIRING INTERVENTION HAS TO BE CARRIED OUT EITHER AT THE DEALERS' OR AT THE C.I.M.A. S.p.A. AUTHORIZED WORKSHOPS, OTHERWISE ANY KIND OF WARRANTY IMMEDIATELY CEASES AND C.I.M.A. S.p.A. IS CLEARED OF ANY CONSEQUENT AND/OR IMPLIED RESPONSIBILITY.**

#### A. FAULT: Leakage and dripping from the pump

- CAUSE: Non-sealing of the fittings and clamps connecting the piping to the pump.  
**REMEDY:** Check for proper tightening of ring nuts and clamps. Check the efficiency of the sealers. Replace parts that are possibly found to be defective.
- CAUSE: Mechanical sealing defective.  
**REMEDY:** Address a C.I.M.A. point of "Sale and Service".

#### B. FAULT: Drop in pressure of the hydraulic circuit marked by the gauge

- CAUSE: Dirty filter.  
**REMEDY:** Clean the cartridge
- CAUSE: The pump filter is clogged.  
**REMEDY:** Clean the filter
- CAUSE: Faulty sealing of the hydraulic circuit.  
**REMEDY:** Check the operation of the pump and the tension of its belt. Check the proper tightening of ring nuts, fittings and clamps. Check the efficiency of the sealers and the integrity of the piping. Replace the parts that are possibly found to be defective.
- CAUSE: Pressure gauge defective.  
**REMEDY:** Replace the pressure gauge.
- CAUSE: Suction or gauge connection pipe clogged.  
**REMEDY:** Clean.
- CAUSE: Suction valve clogged.  
**REMEDY:** Clean the valve. For the future, always use the basket filter during the filling operation so to avoid the issue.

#### C. FAULT: Variations in the pressure of the hydraulic circuit (marked by the gauge)

- CAUSE: Lack of seal of the pipes and/or the valves.  
**REMEDY:** Check the clamping of the ring nuts, the connections and the clamps. Verify the efficiency of the gaskets and the integrity of the pipes. Replace the possibly defective parts.
- CAUSE: Residue of product at the entrance of the gauge  
**REMEDY:** Clean.
- CAUSE: Wrong positioning of the circuit-washer faucet (P15) with the circuit-washer tank empty.  
**REMEDY:** Position the lever of the faucet correctly (P15 - pos. 1") and fill the circuit-washer tank.
- CAUSE: Lack of seal of the O-Ring gasket of the pump suction connection (cone).  
**REMEDY:** check the correct assembling and the efficiency of the O-Ring gasket, if necessary replace the gasket.

#### D. FAULT: Vibrations of fan unit.

- CAUSE: The tractor and of the atomizer PTOs are not lined up or their position determines the overcoming of the maximum work angle of the drive cardan shaft.  
**REMEDY:** Position the 2 PTOs so that the drive cardan shaft can work correctly.



## 12.5 - TABLE OF MAINTENANCE OPERATIONS

| CHECK   | SEASON START TREATMENTS | BEFORE EVERY TREATMENTS | END OF EVERY TREATMENTS | SEASON-END TREATMENT | RECOMMENDED FREQUENCY |
|---|-------------------------|-------------------------|-------------------------|----------------------|-----------------------|
| Fan belt-tensioner spring: CHECK LENGHT 9 – 12 cm                           | YES                     | YES                     | **                      | **                   | **                    |
| Pump belt-tensioner spring: CHECK LENGHT 4 – 5 cm                           | YES                     | YES                     | **                      | **                   | **                    |
| Fan belt-tensioner support: GREASING  | **                      | **                      | **                      | YES                  | 200 hours             |
| Filter: CHECK CLEANING  | YES                     | YES                     | YES                     | YES                  | **                    |
| Tank level gauge: CHECK CLEANING AND GOOD CONDITIONS                        | YES                     | YES                     | YES                     | YES                  | **                    |
| Fittings and piping: CHECK GOOD CONDITIONS                                  | YES                     | YES                     | **                      | YES                  | **                    |
| Clamps and fittings: CHECK FOR INTEGRITY, PERFECT SEALING AND TIGHTENING    | YES                     | YES                     | **                      | **                   | **                    |
| Drawbar: CHECK THE SCREWS AND FIXING BOLT TIGHTENING                        | YES                     | YES                     | **                      | YES                  | **                    |
| Wheels: CHECK THE SCREW NUTS TIGHTENING AND TYRES PRESSURE                  | YES                     | YES                     | **                      | YES                  | **                    |
| Axle and Wheel hubs: CHECK THE NUT TIGHTENING AND CHECK THE BOLT TIGHTENING | YES                     | YES                     | **                      | YES                  | **                    |
| Hydraulic circuit and tank: COMPLETELY DRAIN AND WASH                       | **                      | **                      | YES                     | YES                  | **                    |
| Sprayer: EXTERIOR WASHING   | **                      | **                      | YES                     | YES                  | **                    |
| Sprayer: STORAGE  | **                      | **                      | **                      | YES                  | **                    |

## 3.5 - HANDLING OF AGRO-CHEMICALS

The **operator** could become contaminated due to accidental spray, contact or inhalation of products or crop-spraying mixtures.

The **environment** could become polluted by mixture over-spills, puncturing of containers, uncontrolled storage of used and unwashed containers or spillage into waterworks.

In order to avoid these risks the preparation and filling operations must be carried out in suitably appointed and adequately equipped sites.



**To use pesticides (purchase, transport, loading, treatment planning, mixture preparation, field transfert, treatment performance, ending treatment liquid waste management, equipment rinsing and waste disposal) you must follow the country rules.**



**Absolutely respect the rules on the label of the product used referring to the dose for hectar and to the compatibility of other products.**

### 3.5.1 - Storage

**Fixed / stationary:** the site used must be well ventilated and secured by lockable doors in order to prevent even accidental access by children or unauthorised persons.

**Mobile:** the carrier equipment must be properly locked and kept under conditions whereby access by children or unauthorised persons can be prevented during the absence of the operator. All full or partially utilized containers must be secured against tipping, falling or breakage during transportation.

Both types of storage must:

- have a suitable container for the storing of empty packaging materials should a specific storage area not be available;
- have a clean water supply readily available for washing, by means of a specific container or through connection to the waterworks system;
- have the use of fire extinguishers, should flammable products and substances be stored.



- **All packages, whether whole or partially utilized, must be stored in their original packing and with the warning instructions clearly displayed and legible.**
- **The storage indications must always be scrupulously adhered to, as well as their utilisation and possible disposal as suggested on the product's original packaging.**

### 3.5.2 - Specific equipment

The site at which the preparation and filling out will take place must provide for:

- all the equipment necessary to the precise measuring of both the water quantity and the dose of product to be mixed in the tank at every filling;
- all the equipment and means useful to the preparation of the mixture and for the cleaning of the operator in case of contamination;
- all tools necessary to facilitate the direct introduction of the agro-chemicals in the tank;
- the allocation of clothing and specific equipment in order to avoid contamination by contact or inhalation during the whole operative phase of the intervention;
- the availability of proper equipment able to stop the uncontrolled spilling and flowing of the mixture;
- a retaining valve on the feed pipe when the filling of the tank takes place directly from the waterworks system.

### 3.5.3 - Disposal of empty containers and agro-chemicals residues

Agro-chemicals are classified as "special" waste and their disposal must take place separately from "urban" wastes.



**Empty packaging and contaminated containers to be done away with cannot be dispersed, burned or buried.**

**The washing water for the cisterns and the tools utilized for the preparation of mixtures cannot be emptied on the ground, spilled into the sewage system or in waterways and rivers.**

The disposal of special wastes is regulated by specific norms. In order to perform this operation it is necessary to obtain the relevant information from the Local Offices specifically appointed to rule on this subject. The non compliance with these regulations can cause considerable damage to persons and animals as well as polluting the environment.

### 3.5.4 - Personal Protective Equipment (PPE)

The use of phytosanitary products might imply a more or less high chemical risk for the workers on the basis of the toxicity and the dangerous properties of the phytosanitary product, of the level and duration of the exposure, of the absorption level through the respiratory tract, the skin, the mucosa and the ingestive tract, as well as the way and frequency of the use.

The "personal protective equipment" (PPE) are equipment that all the users of the machine need to wear and hold in order to be protected by one or more risks that are capable to treat the security or healthy during the job.

Regarding the basic requirements, PPE have to:

- be suitable to the risks that have to be prevented, without causing major risks themselves;
- be suitable to the existing conditions on the workplace;
- consider the ergonomic (easily adaptable, easy to wear and safe) or health needs for any users;
- be adaptable to the user according to his/her needs.



**Use solely PPE equipped with the needed mark, in the scrupulous respect of the regulations in force in the country where the machine is in use and adequate to the phytosanitary product used.**

It's needed to use the PPE in each of the following working stage:

- tank filling and addition of the phytosanitary product;
- spraying,
- calibration of the sprayer,
- draining and cleaning of the tank,
- phytosanitary product replacement,
- servicing.



### 12.3 - FAN BELT TENSIONER

Check length "L" of the spring (refer to Picture): it should be in tension between **9 and 12 cm**.

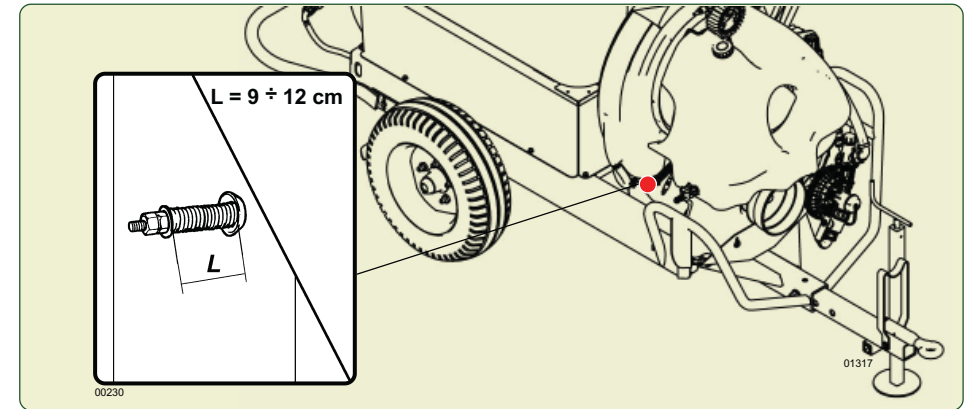

**If the fan control belt has to be replaced, the correct tensioning of the same one (spring length) has to be OBLIGATORILY checked after the first and after the second operation hour. If the value measured exceeds 12 cm, tighten the belt tightener screw, up to get the minimum length (9 cm).**

The belt setting will take place within the first 2÷3 operating hours; when that time has elapsed, verify the spring length, according with the time intervals (periodicity) indicated in the "Maintenance operations" table".

### 12.4 - PUMP BELT TENSIONER

Check length "L" of the spring (refer to picture): it should be in tension between **4 and 5 cm**.

If the value measured exceeds 5 cm, tighten the belt tightener screw, up to get the minimum length (4 cm).

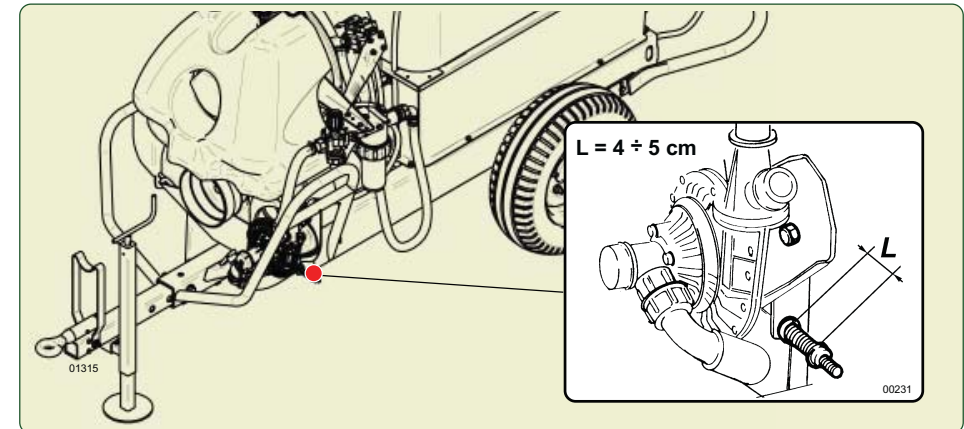



ALL OPERATIONS MUST BE CARRIED OUT WITH THE ENGINE SWITCHED OFF AND WITH THE IGNITION KEY REMOVED FROM THE CONTROL PANEL.



The machine has to be periodically revised according to the country rules. The inspections and the release of the certificate have to be made by special provided structure of the country where the machine is used.

### 12.1 - LUBRICATION



Carefully clean the greasing nipples and the oil filler in order to avoid that, during lubrication, dirt might be introduced. In the case of intensive use of the machine, reduce the lubrication intervals.

- Remove the oil drain plug and let the oil completely flow out from the fan shaft support.

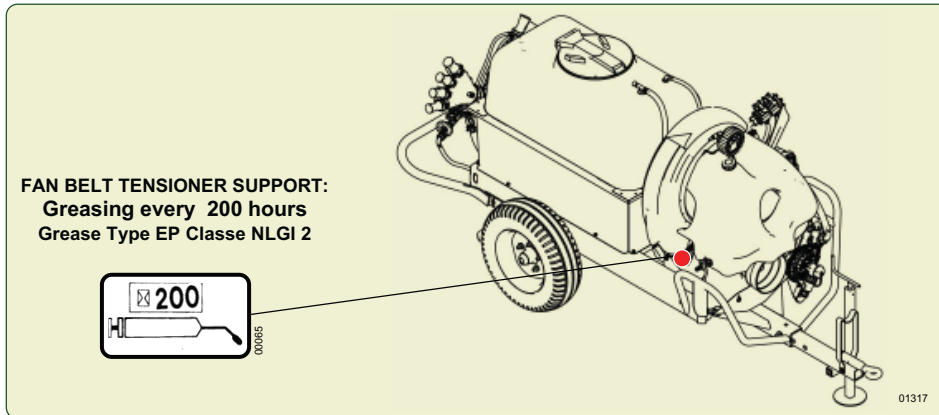

### 12.2 - CLEANING OF FILTER'S CARTRIDGE

- Set the lever of tap (P2) to the "C" position.
- Completely close the pressure regulator, by turning clockwise the handle of the manual regulator (P5).
- Undo the thumb screw and remove the body of the filter.
- Extract the cartridge: clean the grill and the retaining O.Ring.
- Reassemble the cartridge and secure the lid with the thumb screw. **Pay attention to the O-Ring of the lower body during the assembly:** the incorrect sealing of the filter will jeopardise the proper operation of the sprayer and cause loss of the mixture.

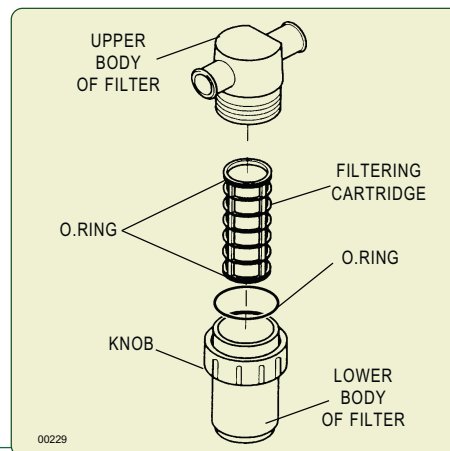

The following must be worn:

- for the protection of the body (gloves, suits, boots),
- for the protection of the respiratory tract, of the head and of the eyes (helmet, masks, filters, glasses, hoods and headdresses).



Filters must be replaced following the producers' instructions, and in any case:

- in case a bad smell is noticed;
- in case a resistance to the respiratory function is noticed;
- at least once a year in case of occasional use.

For ALL PPE in use, follow the use instruction declared by the PPE producers.

4 MACHINE'S STRUCTURAL ANALYSIS 4

The pictures indicate the position of the main components of the sprayer.

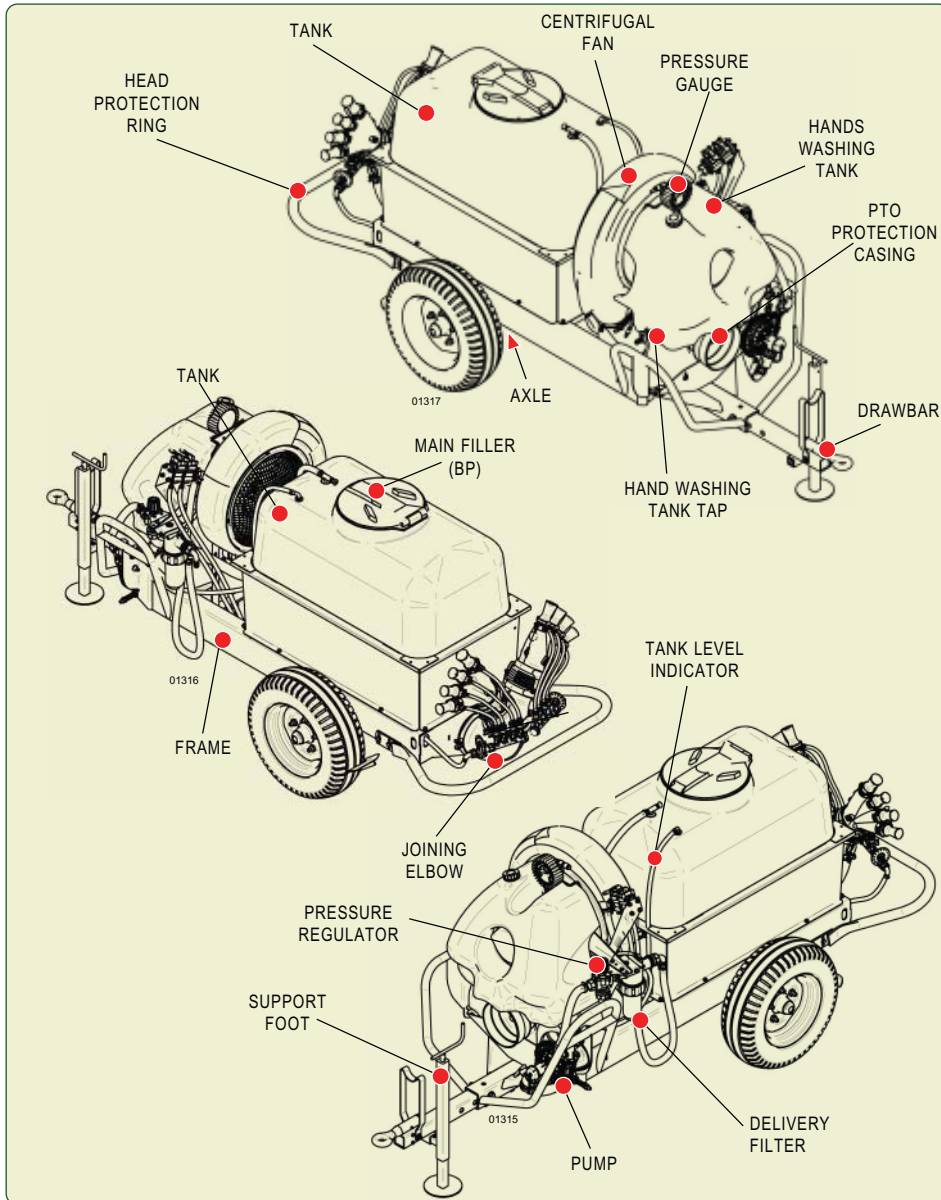

11 LIFTING AND TRANSPORT 11



THE FOLLOWING ACTIONS ARE NOT ALLOWED:

- Transporting or lifting the sprayer with residual quantities of mixture in the tank for purposes differing from its destined usage.
- The transporting of people, animals or things.
- The trailing of vehicles or equipment.



Road transport must take place in the complete observance of road regulations in force in the Country where the machine is used. The operator is responsible for possible defaults due to the non observance of said regulations.

• Lifting and transport of the sprayer



Before carrying out any operation it is essential to verify that no mixture residues are left in the tank.

1. Check that the lifting devices (bands, ropes, etc.) are adequate for the weight to be lifted (machine – distribution devices - accessories).
2. Hook the machine through the specific support point indicated by the specific decal on the frame, checking all the parts involved in the operation.
3. Lift the machine, verifying that it is properly balanced.

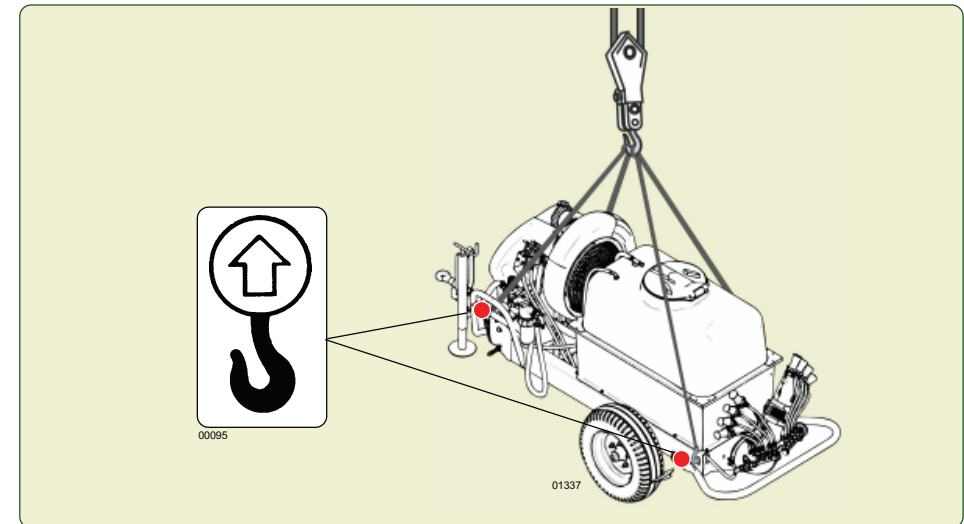

4. Position the sprayer on the transporting vehicle in perfectly stable conditions.
5. Lock the sprayer with the wedges locking wheel.
6. During transport the machine must be immobilised and fastened to the carrier by way of suitable strapping.



- Stop the grape harvester and remove the key from the control panel.
- Wear suitable protective clothing and accessories in order to avoid contamination by contact or inhalation of the mixture.
- Carry out the discharging in a suitable and properly geared area for the collection of the washing liquid.

1. Unscrew the drainage plug on the T-fitting (P16).
2. When the draining is completed screw again the drainage plug.

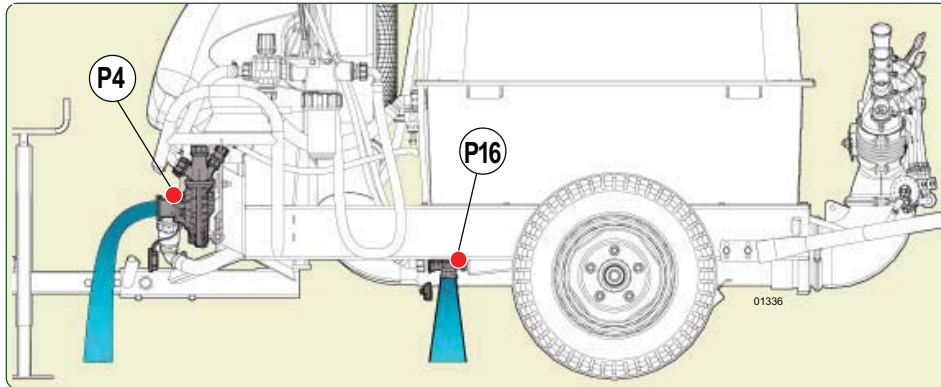

3. Unscrew the chain plug on the pump (P4).
4. When the draining is completed screw again the chain plug.

### 4.1 FRAME WITH DRAWBAR

**DRAWBAR WITH STANDARD TRAIL EYE.** It is inserted in the frame front section; its position is regulated by means of the insertion of a through safety screw (2), provided with a self-locking screw nut. The drawbar is locked by means of the two lateral screws (1), foreseen for this purpose

- Adjustable in height for 9,5 cm
- Adjustable in length, with displacements of 8 – 16 – 24 – 32 cm.



After every regulation, carefully tighten the two fastening screws

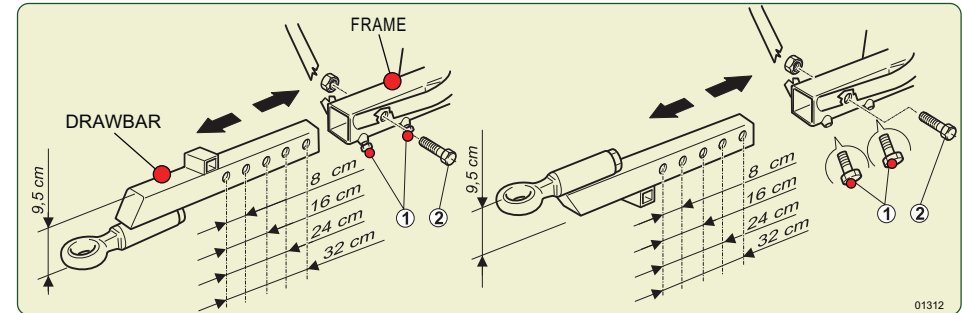

**SUPPORT FOOT** with crank regulation.



**ALWAYS** use the adjustable support foot, in order to stabilize the sprayer when it isn't hitched to the tractor.

**SUPPORT BRACKET** mounted on the drawbar, in order to house the transmission shaft when the machine isn't hitched to the tractor (Position A).



When the transmission shaft is mounted on the 2 PTO (tractor-sprayer), the bracket has always to be lowered (Position B).

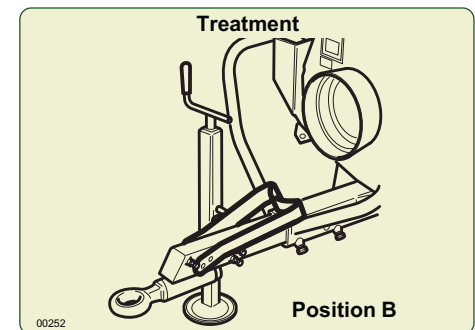
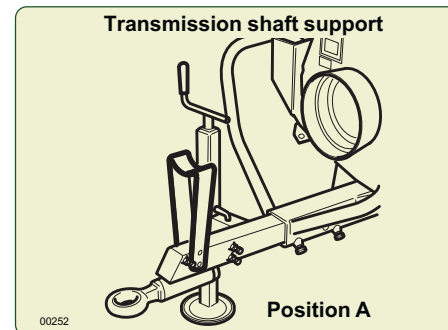
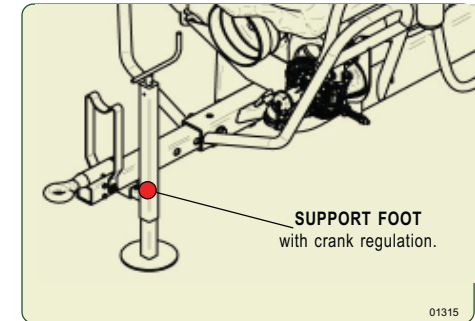

**AXLE.**

The wheels' axle shafts, inserted in the frame axle and locked there by some especially foreseen screws, allow to regulate the **track width**, by adapting it to the intervention requirements.

— The height with respect to the ground can be regulated. (The misalignment between the axle shaft and the wheels' hub allows a variation of 12 cm). It is enough to turn the axle shafts.

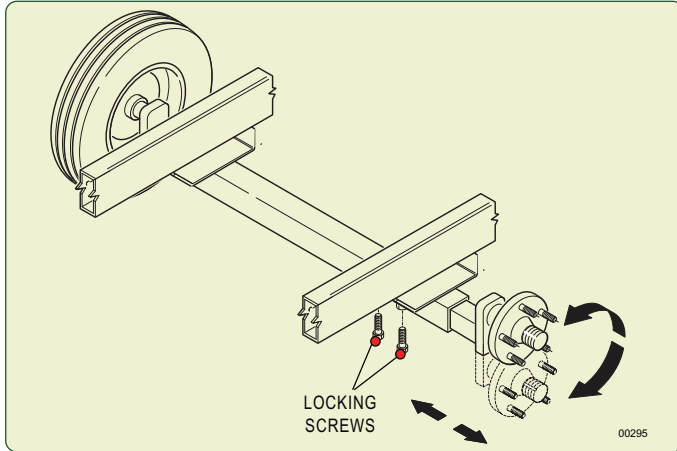

**After every regulation, carefully tighten all the screws and the bolts concerned by the intervention. THE RESPONSIBILITY FOR THE REGULATION, ASSEMBLY AND DISASSEMBLY OPERATIONS OF THE WHEELS IS CHARGED TO THE OPERATOR, WHO HAS TO PREPARE AND TO ASSURE THE NECESSARY CONDITIONS FOR A COMPLETE SAFETY AGAINST ANY POSSIBLE ACCIDENT.**

**WHEELS.**

The tyres' size and the operating pressure are indicated at step 4.4.2.

**HEAD PROTECTION RING.**

It is applied behind the machine, in order to protect the distribution devices (heads). It has to be mounted in the most efficacious position, according with the working conditions and with the kind of head.

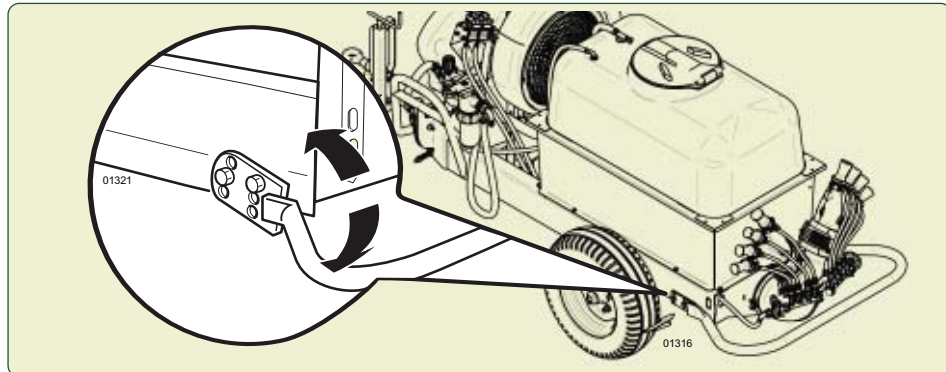

**9.4.2 - End of seasonal cycle**

• **The operator must:**

- a. Take the utmost care in carrying out the operations envisaged at the end of the daily treatments: the cleaning of the hydraulic circuit must be done at least twice. Check that no product residues are left in any part of the circuit.
- b. Execute the necessary maintenance and lubrication operations (see paragraph 12.5), then let the atomizer operate for some minutes.



**THE PUMP MUST NEVER RUN DRY**

- c. Completely drain the hydraulic circuit, paying a special attention to the centrifugal pump; in order to completely drain the pump, remove the draining plug, which is mounted on the pump itself.

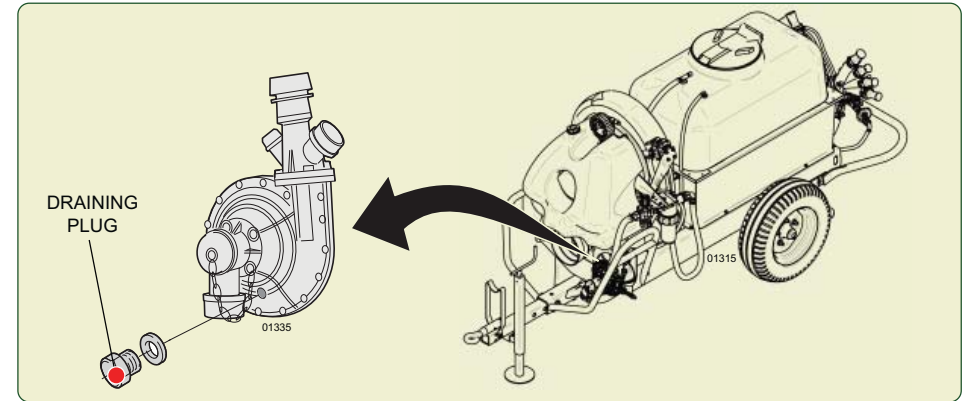

**Avoid using anti-freeze solutions.**

- d. Check the proper operation of all parts and of the machine structure. In case of faults being detected, request the intervention of one of our service points.
- e. Keep the machine on a plane surface with a suitable consistency, in a well ventilated place, sheltered from rain, icing and direct sun rays.



**The machine must be stored in a secure or closed place, so as to prevent access to unauthorized personnel.**

- g. Keep to the preliminary operations already indicated (9.1.c), in case of wind conditions prevailing.
- h. During the breaks, stop the engine, remove the key from the grape harvester's control panel.
- i. Pay particular attention to the treatment when close to boundaries and in proximity of dwellings, waterways, roads or public-usage paths.

## 9.4 - END OF TREATMENT - STORAGE

### 9.4.1 - Daily

#### The operator must:

- a. Put about 15 lt. of clean water in the tank and spraying it in the already treated area.
- b. Wash the tank:
  - 1. Wash the main tank internally with a water jet employing a quantity of clean water equal to almost 10% of tank capacity
  - 2a. Discharge the rinsing water in a proper area provided with a drain basin for the collection and take care of waste according to the country rules.

Or

- 2b. Spraying the rinsing water in the already treated area. Then, discharge the remaining water of the tank and pipes gathering it in a proper container to waste it following the rules or use it again, putting it again in the tank, for a next treatment, if this will be suitable with the product to use.

If necessary repeat the washing procedure.

- c. Wash the machine externally:



**To wash it externally DO NOT USE high pressure washer (MAX 5 bar).**

When each treatment has finished, it must wash the sprayer outside, in a proper area provided with a drain basin for collection and subsequently treatment of rinsing water.

These areas are forbidden to unauthorized personnel, children and pets.

To outside sprayer rinsing, it is possible to use proper cleaning products and biodegradable to make the operation easier.

When the rinsing is finished, switch on the fan for few second (about 10) to remove residual water on carter and pipes which lead the flow to the sprayhead.

- d. Check the efficiency of the distribution device (head) and the cleaning of the pulverising points (diffusers), possibly replacing them if found to be damaged.
- e. Clean out the filter cartridge.
- f. Keep the machine in a ventilated place, sheltered from rain or sun: sunrays are the worst enemies of plastic and rubber parts.



**The machine must be stored in a secure or closed place, so as to prevent access to unauthorized personnel.**

## 4.2 - FAN SERVO AMPLIFIER

It is positioned in the unit front section and protected by a plastic casing.

### Servo amplifier

It is equipped with an automatic tensioner of the driving poly-V belts that keeps the belt tension constant, avoiding slipping and wear.

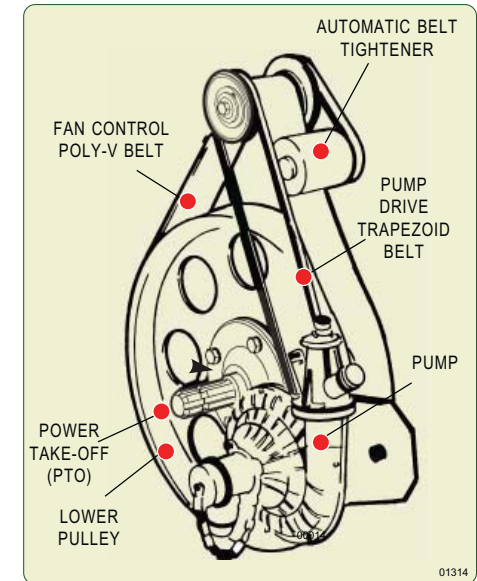

### Centrifugal fan

An air intake predisposed on the casing external edge is connected, by means of a pipe equipped with a cock, to the tank inner agitator.

Through this tap it is possible to carry out or exclude pneumatic agitation.

The closed vanes-type impeller is realized in dynamically balanced sheet steel; the air intake opening on the casing is protected by a grating, especially foreseen for this purpose.

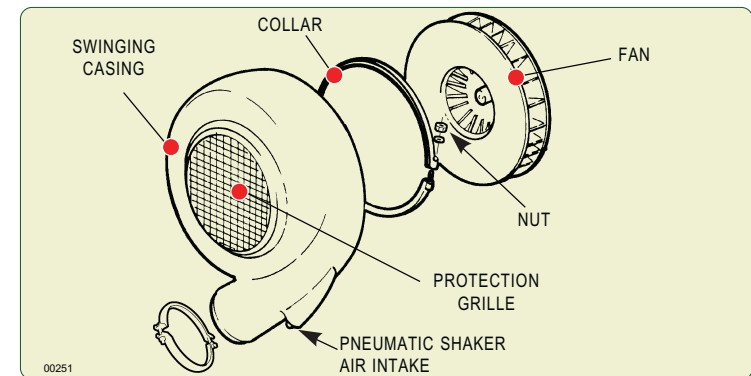

## 4.3 - HYDRAULIC CIRCUIT

### 4.3.1 – Operating principle

WORK – The tank (P1) contains the mixture that need to be sprayed on the growings to treat. The tank (P1) is connected with the pump (P4) by the tap (P2). When the tap (P2) is in position “A” - **WORK**, the mixture is sucked by the pump (P4) and sent to the pressure regulator (P5) and to the distribution device (sprayhead). The regulator (P5), together with the correct position of the rotating disc regulator, allows to modify the spraying pressure of the sprayer so to can reach the correct litres/hectare distribution needed; the exceeded quantity of the liquid supplied by the pump through appropriate pipes is directed inside the tank in order to mix the mixture.

On the delivery to the distribution device (sprayhead), after the pump, the delivery filter is placed (P7); from the filter through the pipe (T4), the mixture to spray reaches the manual distributor (P9) that allows the mixture spraying (when open).

### 4.3.2 - Hydraulic circuit components

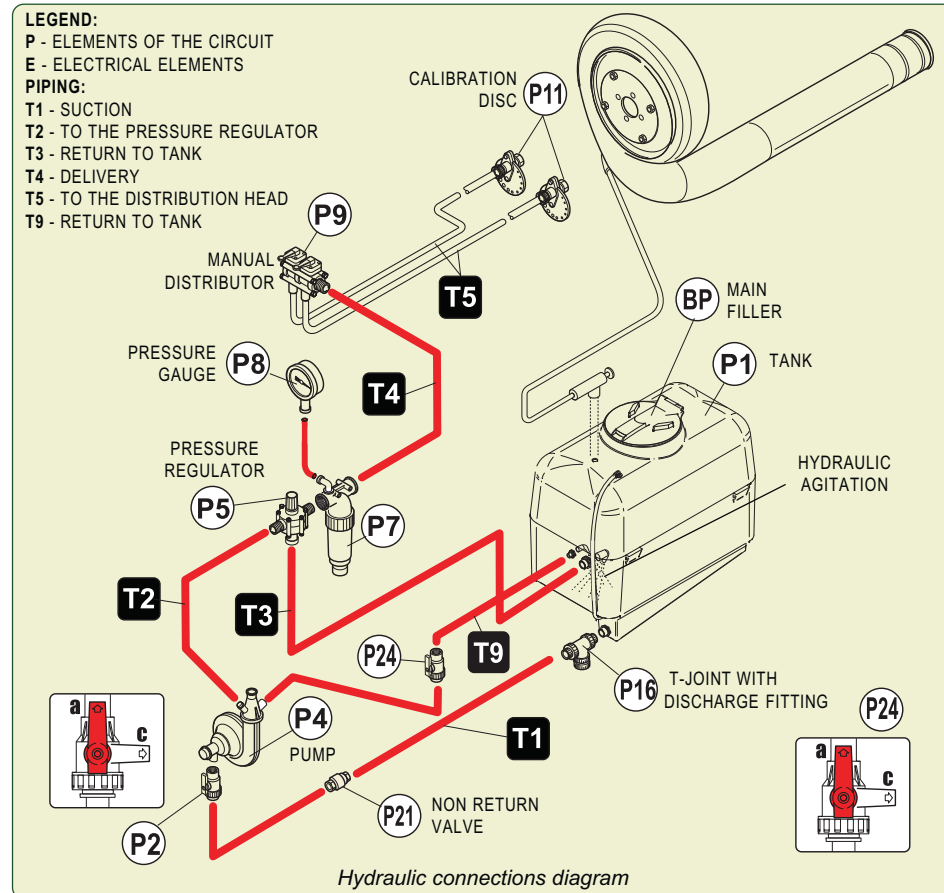

01311-2

- g. Wash and rinse the just emptied product containers with clean water – collect the washing water and pour it in the tank before carrying out the filling – place the empty packaging in the specific container or in the collection area.
- h. Wash the equipment and tools utilized in the preparation and place them in the chemical products storage area.
- i. **Always** leave the area assigned to the loading and preparation of the mixtures in such condition as to avoid **any** possibility of contamination to persons or animals or of pollution to the environment.
- l. If necessary, mark the field or the area of machine passes in order to provide a guide for the treatment and avoid missing or double-treating coverage areas.



- **AT THE END OF THE OPERATIONS NECESSARY FOR CARRYING OUT THE INTERVENTION, THE LOCATION-STORAGE AREAS MUST BE LEFT IN THE CONDITION REQUIRED FOR THE CARRYING OUT OF THEIR PREVENTION AND PROTECTION FUNCTIONS.**
- **BEFORE STARTING THE GRAPE HARVESTER, KEEP AWAY PERSONS OR ANIMALS AND NEVER LEAVE IT UNATTENDED DURING THE PREPARATION OPERATION.**

## 9.3 - THE TREATMENT



IT IS ADVISABLE TO BEGIN TREATMENT AT THE HEADLANDS.



**When the treatment is over, or if the same has to be temporarily interrupted, always let the fan still operate for approximately 10 sec after cutting-out the power supply (manual distributor P9), in order to fully eliminate the product mixture from the distributing devices, so preventing any possible anomalous dripping from taking place.**

- **The operator must:**
  - a. **Shake the mixture** in the tank before starting the treatment, re-circulating it completely for as long as it takes to make it homogeneous.
  - b. **Check** the orientation of the distributors (hands and/or cannons) of the distribution device (sprayhead) in relation to the dimensions, the shape and the thickness of the vegetation to be treated.
  - c. Continue to shake the mixture until the treatment is resumed should the intervention momentarily be interrupted. If the utilisation is to be deferred, check that the filter cartridge is clean before resuming and **agitate the mixture** that has remained in the tank.
  - d. Ensure that the hand wash supplementary tank is filled with clean water after each filling operation.
  - e. Make use of individual protections identical to those envisaged for the preparation of mixtures if the tractor is not equipped with a pressurised cabin with aeration filters.
  - f. Wash immediately all the elements that might have become contaminated during the treatment, promptly remove the polluted garments and **interrupt the work if these cannot be immediately replaced.**



- d. Check that multiple-product mixtures be physically, chemically and biologically compatible amongst themselves; if need be, obtain the necessary information from the products' sales representative.
- e. Carefully calculate the exact quantity of the product necessary for the treatment and establish the volume of water to be used for the intervention.
- f. Check that the product is available in a quantity sufficient to complete the intervention.
- g. Read the product's utilisation instructions carefully, in order to ascertain the usage conditions, the correct dosage and the expiration dates.
- h. Make sure of the parameters necessary to the adjustments of the machine and determine the exact dose of product to be applied to every loading. **Follow the instructions of the publication titled "The low volume - Instructions for sprayers adjustment" as well as those contained in the use and maintenance book-let of the distribution device.**

## 9.2 - PREPARATORY OPERATIONS TO TREATMENT



**THE FILLING MUST BE CARRIED OUT WITH THE MACHINE ON A FLAT SURFACE. BEFORE THE OPERATION, IN THE ALLOCATED AREA, THE DOSES OR MIXTURES TO BE POURED IN THE TANK MUST BE MADE READY.**

Before starting the filling cycle, check:

- THE TIGHTENING OF THE RUDDER, AXLE, HUBS AND WHEELS FIXING BOLTS SCREWS;
- TYRES PRESSURE;
- THE CLEANING OF THE FILTER CARTRIDGE (P7);
- THE EFFICIENCY OF THE DISTRIBUTION DEVICE (HEAD).
- THE CONDITIONS OF THE TANK LEVEL INDICATOR.

• **The operator must:**

- a. Wear adequate protective clothing and accessories such as overalls, waterproof suits, gloves, glasses and masks to shield him from contamination by inhalation or contact with the products handled.



- **Anti-dust masks don't offer any protection against toxic vapours.**
- **Avoid wearing loose clothes that might entangle with moving parts.**

- b. With the parameters defined during the preliminary operations, carry out the adjustments of the sprayer.
- c. Prepare the mixtures in a well ventilated area. When in the open, the presence of wind increases the danger of contamination.
- d. Precisely weigh the previously calculated doses of products to be mixed at every filling operation.
- e. Avoid handling products close to open flames, embers, incandescent bodies or in the presence of flammable substances.
- f. In order to obtain the correct volume dosage of agro-chemicals and fertiliser mixtures, the fertiliser must be first diluted.

## P1. MAIN TANK

Polyethylene tanks of 400 litre capacity.

Each tank is made up of:

- tank main filler, (BP) with a 355 mm. diam.hinged cover, with breather pipe;
- Plastic cup-like filter: 302 mm external diameter, height 254 mm;
- transparent level indicator external pipe with graduated scale, (One on the front side of the tank);
- double hydraulic agitation;
- pneumatic agitation;
- piston cock, positioned over the tank and connected through a pipe to the air inlet, which is placed on the fan casing, for opening/closing the pneumatic agitation.

## P22. ADDITIONAL HAND-WASHING TANK

30-litre polyethylene tank, with external tap.

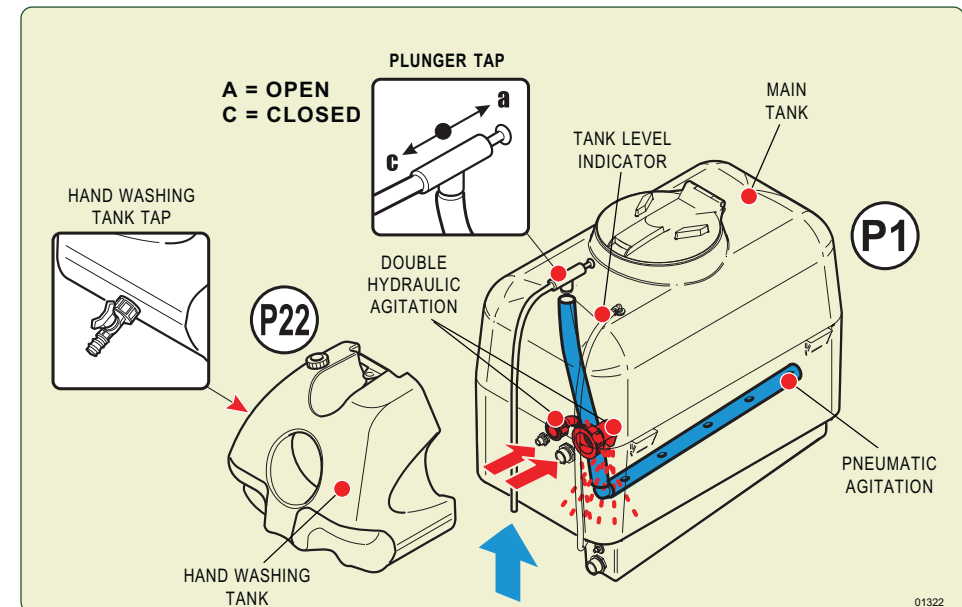

## P16 - T-FITTING WITH DISCHARGE PLUG

Directly connected to the tank before the suction pipe (T1), it allows, by removing the plug, the drain of the tank.



**WARNING: the tank contains PHYTOSANITARY PRODUCTS. Discharge in an area equipped with catch basin and provide to draining in the scrupulous respect of the local regulations in force.**

## P2. LEVER TAP

Positioned on the pipe (T1), between the tank (P1) and the pump (P4).  
The lever (P2) can be positioned as here following specified:

### A - Treatment

The liquid gets out from the tank (P1) and is sucked by the pump (P4); this is the **NORMAL** operating position, which is used in order to carry out the treatment and/or to keep the mixing agitation on.

### C - Closed

In this position the suction is closed to allow the pump maintenance.

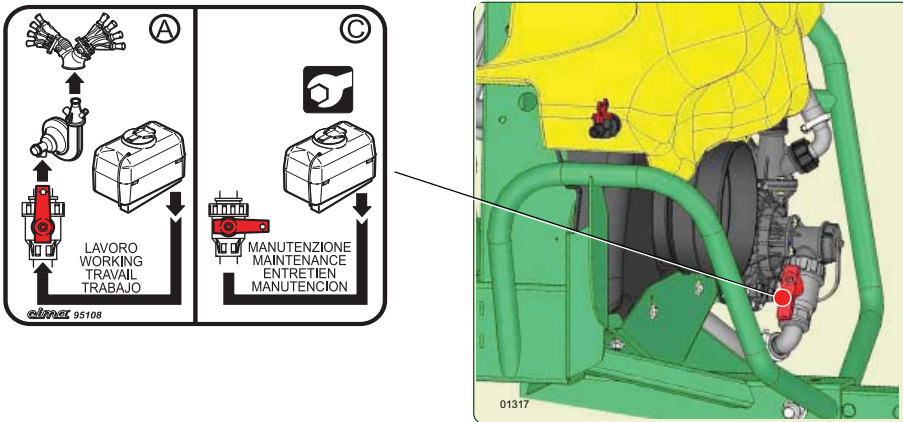

## P4. CENTRIFUGAL PUMP

Fastened on the unit left front section, it is connected with the cock (P2) and with the pressure regulator (P5). The pump is provided by the suction side of a filter to prevent the accidental entry of foreign bodies in the pump body, such a possibility does not constitute a hazard and can only cause damage to the impeller shown by a drop in pressure reported by gauge.

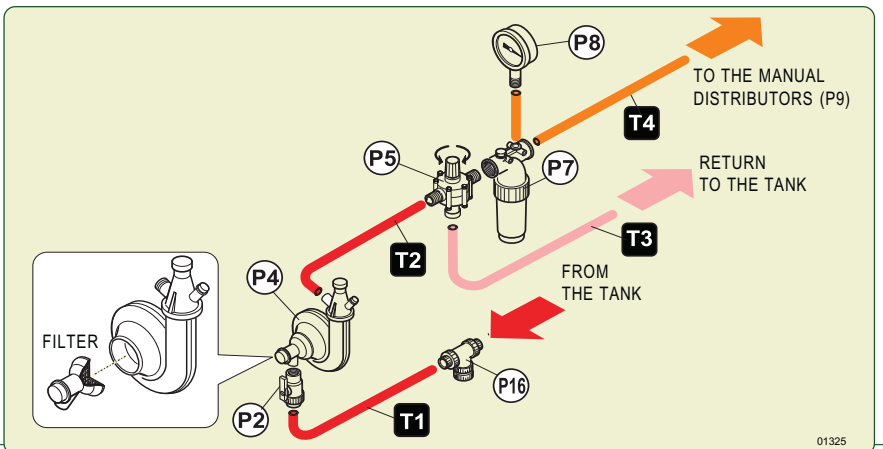

## 8 AGITATION 8

The **hydraulic** and the **pneumatic** circuits mounted inside the tank, allow to realize a **double agitation system**: with the pump water and with the fan air, **at the same time**. The pneumatic circuit can be excluded, when the products used have a quite strong foaming effect, by closing the pneumatic agitator cock. When that cock is opened again, check that some air outlet holes aren't obstructed.

**It is advised however to also use always the pneumatic agitator, adding to the mixture, if necessary, a antifoam product.**

This operation is of main importance, in order to get a uniform distribution of the active principle on the whole vegetative surface to be treated. Should the activity need to be interrupted during a treatment with the sprayer, **keep the agitator activated until the treatment is resumed**.

**Before starting the treatment, or return to work after a break, it is essential to agitate the mixture in the tank, re-circulating it completely for as long as it takes to make it homogeneous.**

**The agitation can be carried out with the manual pressure regulator (P5), in any position. The tap of the pneumatic regulator has to be open.**

**THE MIXTURE AGITATION HAS TO BE CARRIED OUT WITH THE POWER TAKEOFF RUNNING AT A RATE OF AT LEAST 500 RPM..**

## 9 OPERATING PROCEDURES 9

**Before using the atomizer fill the hand-washer tank with clean water.**

### 9.1 - PRELIMINARY OPERATIONS TO TREATMENT

- **The operator must:**
  - a. Ascertain that the condition of the crops, the progress of the disease or the need for its prevention actually justify the treatment to be applied.
  - b. Be aware of the meteorological conditions forecast for all the time necessary for carrying out the treatment.
  - c. If possible, avoid carrying out the spraying in strong wind conditions or when one detects that the sprayed mixture disperses away from the target crop (drifting). It is advisable to suspend the treatment when the wind speed exceeds 3 m/s (10 km/hour). Should it be imperative to operate anyway, the following suggestions are made:
    - reduce the distance of the target from the spraying points, even if detrimental to the quality of the spraying
    - increase the dimension of the droplets, suitably adjusting the machine.

## 7.1 - FILLING PROCEDURE



**THE INLET OF THE FILLER PIPING MUST NEVER COME INTO CONTACT WITH THE ANTI-PARASITIC MIXTURE: IT MUST ALWAYS BE KEPT AT A SAFE HEIGHT ABOVE THE TANK FILLER AND MUST BE EQUIPPED WITH A NON-RETURN VALVE.**



**THE PUMP MUST NEVER RUN DRY**

### EXECUTION:

1. Verify that the lever of the cock (P2) it's in the position "A".
2. Verify that the 2nd delivery of pump exclusion cock (P24) is on "a" position.
3. Close the cocks of the manual 2-way distributor: the levers are to be lowered (horizontally positioned);
4. Pour some water into the tank, for about 1/3 of its capacity.
5. Start the tractor and engage the PTO; **then bring it up to a 500 r.p.m. rate.**



**Use ONLY the PTO at 540 rpm. Engage the PTO with the engine of the tractor at low speed and with maximum modularity, obtaining soft and progressive graft and avoiding abrupt starts of the cardan shaft.**

6. Pour the mixture of water and plant protection product previously prepared (or the liquid product) (and the possible washing water for the medicine packs and for the instruments used for preparing the mixture) into the main filler (BP).
7. Complete the filling with water **by keeping PTO in running.**
8. Close the cover of the main filler (BP).

### IN THE TREATMENT AREA:

9. Start the tractor.
10. Engage the Power Takeoff and set it up to a running rate of at least 500 r.p.m., in order to carry out a further agitation.



**Use ONLY the PTO at 540 rpm. Engage the PTO with the engine of the tractor at low speed and with maximum modularity, obtaining soft and progressive graft and avoiding abrupt starts of the cardan shaft**

11. Regulate the operating pressure, by acting on the pressure regulator (P5) with the manual distributor (P9) open (DISTRIBUTION).
12. CARRY OUT THE TREATMENT (See the paragraph 9.3).



**THE PUMP MUST NEVER RUN DRY**

**The water must be always in the pump : ALWAYS check this point carefully at the start up and during the functioning.**

**To avoid any damage to the pump :**

- At the first filling and at every next filling after the hydraulic circuit draining, fill the tank with an appropriate quantity of water to fill the pump completely;
- In order to control that the pump is not running dry, AFTER engaging the PTO, check that the pressure gauge (P8) shows an operating pressure value above 0 (zero).

## P5. MANUAL PRESSURE REGULATOR

It is connected to the delivery filter (P7) and, through pipe (T3), to the tank (P1). It regulates the operating pressure, by controlling the return flow to the tank.

- **By closing it: it REDUCES the return flow** to the tank and increases the operating pressure and the capacity flow to the head (rotate the handle clockwise).
- **By opening it: it INCREASES the return flow** to the tank while reducing the operating pressure and capacity flow to the head (rotate the handle anti-clockwise).

## P7. FILTER

It is connected to pressure regulator (P5) and, through pipe (T4), to the distributor (P9). The filter has a filtering capacity of 250 l/min., with a 32 mesh cartridge (white). The dirty cartridge causes the operating pressure chute. This inconvenient is signalled by the pressure gauge. Mounted on the feeding pipe, it only filters the delivery flow to the heads, by sensibly reducing the possibility for the cartridge to get obstructed.

## P8. GAUGE

Glycerine-dipped, with dial from 0 to 6 Kg/cm<sup>2</sup> (atmosphere) – adjustments scale of **1/10 of atmosphere**, 100 mm diameter, class 1,6%; it is connected to filter (P7).



**Set the working pressure keeping the manual distributors (P9) opened.**



### P9. MANUAL DISTRIBUTOR WITH 2 LEVER-OPERATED TAPS

It connects the feeding pipe (T4) to the distribution piping (T5). It remote-controls the closing and opening of the pulverising. The mount bracket, supplied with the machine, must be secured to the tractor within the driver's reach. When the machine is not hitched to the tractor, it must be placed on the forward part of the sprayer's frame. Each tap permits the spraying from a single side of the head: to the right and to the left respectively. They are **open** when the levers are set in the **vertical** position. They are **closed** when the levers are **horizontal**.

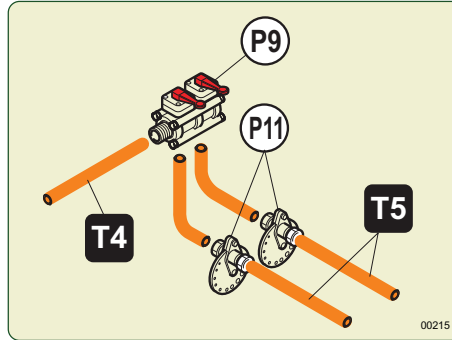

### P11. CALIBRATION DISC (Patent N° 23238)

It selects the flow rates necessary to the treatment and is mounted on the distribution devices. It is made up of 2 flanges, held in position by two butterfly nuts, locking a disc with calibrated holes numbered from 1 to 15. A groove on the edge of the disc allows the exact positioning of the hole to be utilized. Its number must appear in the flange's semi-circular seat. The rotation of the disc is obtained by loosening the butterfly nuts by a few turns. After the operation is done, screw back carefully.



Any faulty sealing condition of the hydraulic circuit causes an intermittent issuing of the sprayed material. It is necessary to carefully check the efficiency of the sealers and clamps, the tightening of the ring nuts and fittings and the good working condition of the piping.

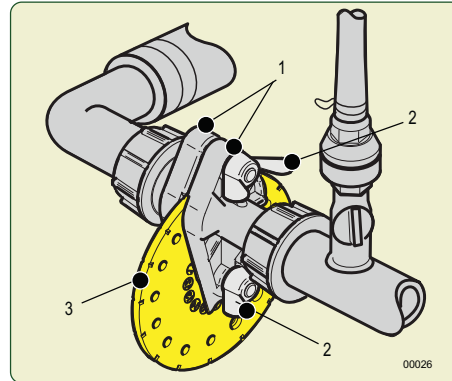

LEGEND

- 1 - UNION FLANGES
- 2 - LOCKING NUT
- 3 - ROTATING DISC WITH CALIBRATED HOLES

### P21. NON-RETURN VALVE

Located on the suction of pump (P4).



The taps (P2 and P24) must be in position "a - open". The taps must be turned in position "c - closed" ONLY when it is necessary to remove the pump (P4) with the main tank still containing liquid.

## 7 FILLING 7

**FILLING MUST BE CARRIED OUT WITH THE MACHINE ON A FLAT SURFACE. ON THE SITE, BEFORE THE OPERATION, THE DOSES OR THE MIXTURES TO BE Poured INTO THE TANK MUST BE PREDISPOSED.**



IT IS NECESSARY TO ALWAYS MAKE USE THE PERSONAL PROTECTIVE EQUIPMENT (PPE) .

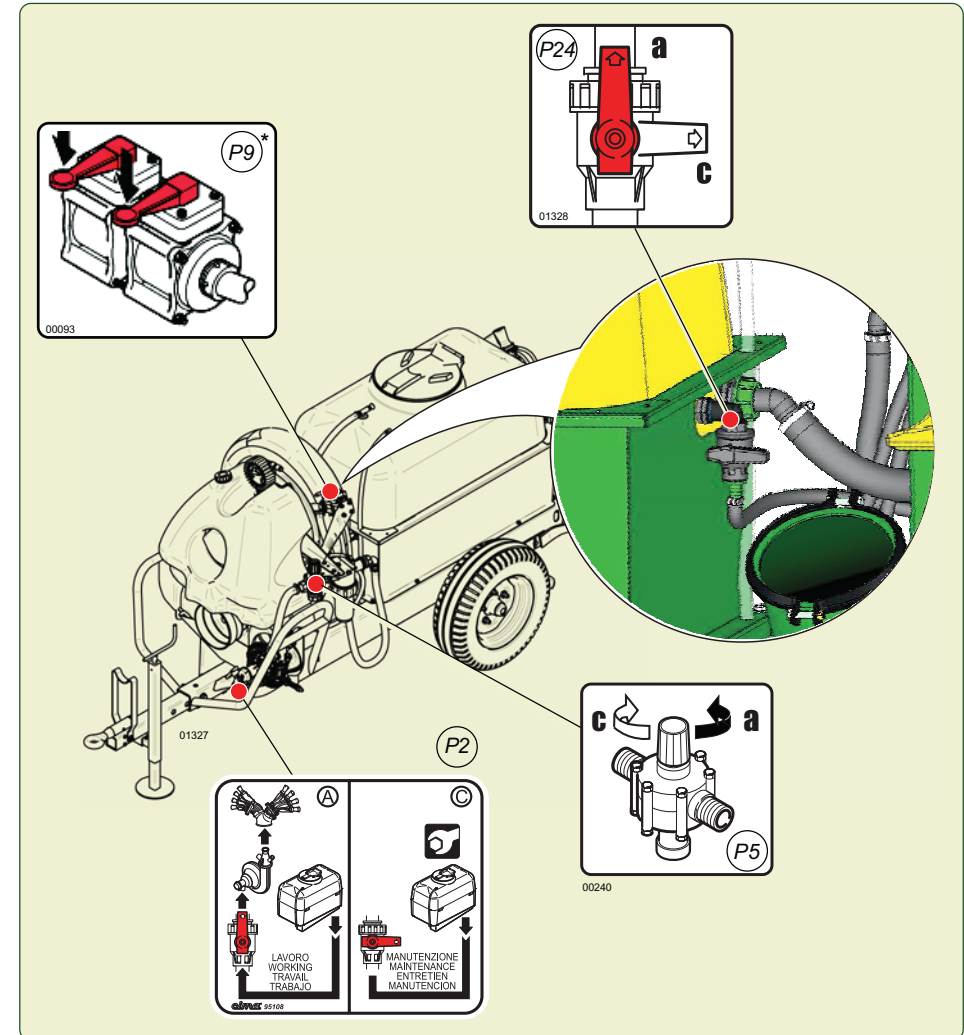



Every distribution device is supplied with its own **USE AND MAINTENANCE** booklet that is, or will have to be, attached to this publication and will constitute one of its integral parts.

The “Distribution devices – Operation and maintenance instructions” manual both shows and describes the wide range of the distribution devices (heads), to be employed on each sprayer in order to assure a perfect covering, always answering to the real requirements of the culture to be treated. All the heads can be very easily oriented and regulated, so to optimise the necessary covering.

**Simple heads**

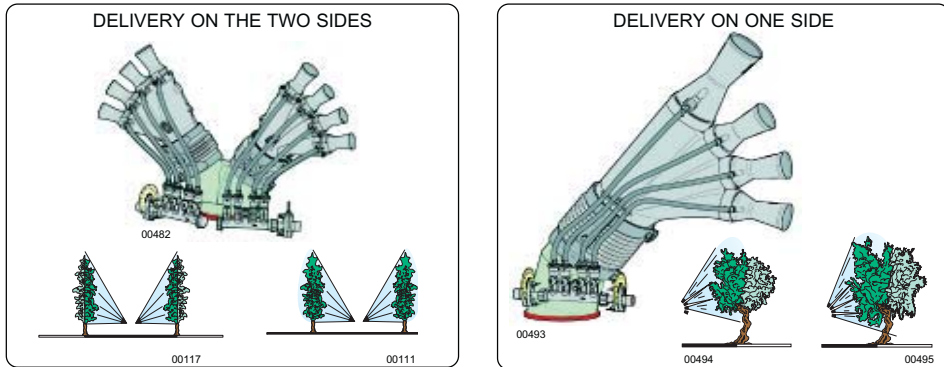

**6.1 - ELBOW FITTINGS OF DISTRIBUTION DEVICES**

The connection elbows both support and connect the distribution devices from the outlet of the connection tunnel, to the fan. The connection elbows are being supplied with the Blitz 42.

Sprayer equipped with:

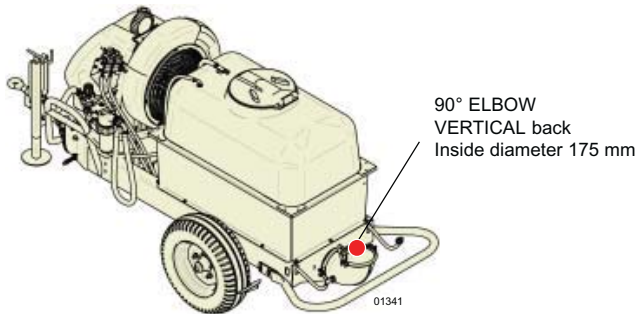

In the handbook “Distribution devices - Operation and maintenance instructions” the right type of elbow is indicated, together with the assembling instructions. A specific assembling diagram of each type of sprayhead is also supplied with the spare parts catalogue.

**P24. 2nd DELIVERY OF PUMP EXCLUSION TAP**

The tap is placed on the pipe (T9) of the second outlet of the main pump (P4) to the main tank (P1). The tap **should be left ALWAYS OPEN** (position "a") during the treatment. The tap must be positioned on "c" (closed) **ONLY** to allow the pump maintenance (P4).

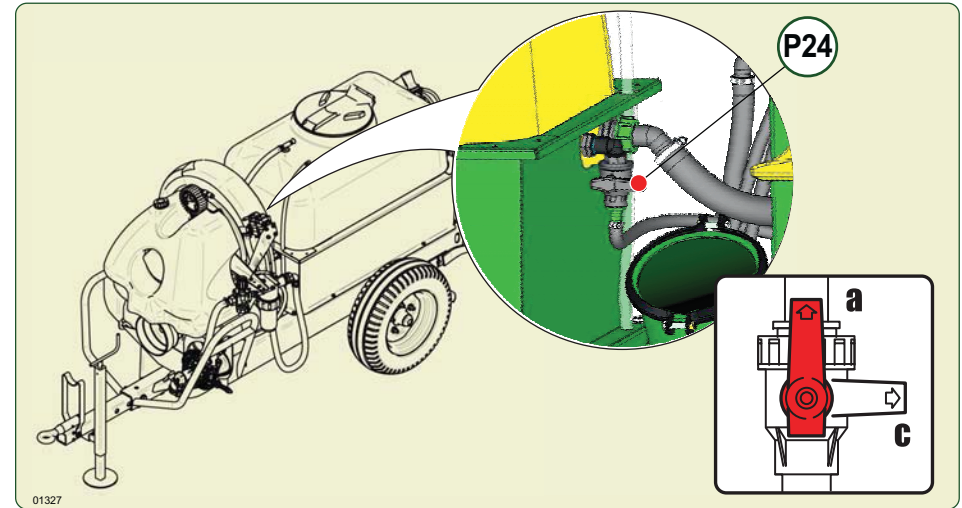

**4.4 - TECHNICAL DATA**

**4.4.1 - Sprayer dimensions and weights**



On the identification plate, the full-load weight (PESO T.) of the machine is indicated, measured **WITHOUT** the distribution device and **WITHOUT** the accessories possibly installed.

In order to calculate the towed weight in operative conditions (at full load), add to the weight indicated on the identification plate (PESO T.), the weight of the distribution device which is used (see “Distribution devices – Use instructions” manual) and the weight of the installed accessories.

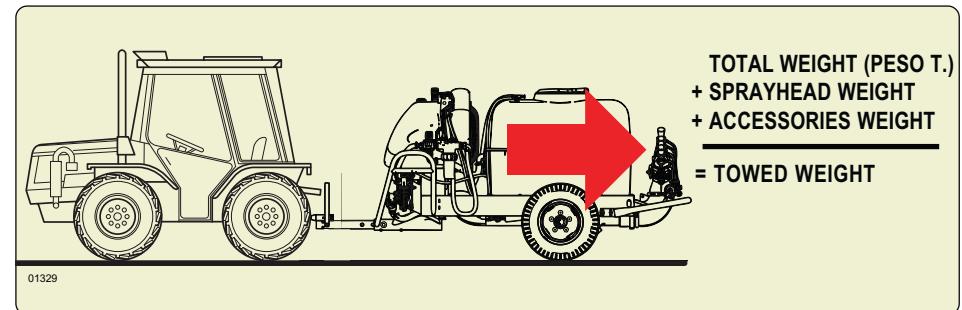

|                        |                |
|------------------------|----------------|
| — Length .....         | 2800 ÷ 3040 cm |
| — Width .....          | 1050 ÷ 1350 cm |
| — Height .....         | 1250 cm        |
| — Whells .....         | 175/70 R13     |
| — Tyres pressure ..... | 2,5 atm        |

#### 4.4.2 - Accesories weight

|  |       |
|--|-------|
| — Constant velocity cardan shaft (KHP.040.120.G) ..... | 16 kg |
|--|-------|

#### 4.4.3 - Centrifugal pump CD32

Model C.I.M.A. CD32 - Grid/filter on suction - Drain plug - Filler for the connection of the filling pipe, with plug with chain.

Activated with trapezoid belt driven by the pulley mounted on the fan shaft.

Technical data printed on the body of the pump.

|                          |                 |
|--------------------------|-----------------|
| — Speed .....            | 4250 RPM        |
| — Flow rate .....        | 120 litres/min. |
| — Suction filter .....   | 7 mm            |
| — Maximum pressure ..... | 4.5 Kg/cm 2     |
| — Power absorbed .....   | kW 2.1          |



The performance specified is obtained with the drive outlet (PTO) at 540 RPM For a good result of the treatments this condition **MUST ALWAYS BE OBSERVED** during the machine's operation. Utilisation is permitted with speed rates ranging between 500 and 620 RPM.



#### 4.4.4 - Filters

|                            |                      |
|----------------------------|----------------------|
| Filter (P7) .....          | 250 lt/min - 32 mesh |
| Tank filling filters ..... | 18 mesh              |

#### 4.4.5 - Tanks

|                                  |            |
|----------------------------------|------------|
| Main tank capacity .....         | 400 litres |
| Hand-washing tank capacity ..... | 30 litres  |

#### 4.4.6 - Fan

|                    |                        |
|--------------------|------------------------|
| Diameter .....     | 450 mm                 |
| Velocity .....     | 4000 RPM               |
| Air delivery ..... | 4000 m <sup>3</sup> /h |
| Air speed .....    | 228 m/sec.             |

## 5.3 - INSTALLATION OF REMOTE CONTROLS

### 5.3.2 - Manual 2-tap distributor - P9

- 1 - Mount the fastening bracket on the tractor within the driver's reach (if this is not already present on the tractor).
- 2 - Insert the distributor's bayonet support in the securing bracket and position it so that the controls are fully visible and accessible during use.
- 3 - Connect the feeding pipe (T4)
- 4 - Connect the distribution piping T5 to the hydraulic circuit of the distribution device (head) mounted on the machine (follow the instructions of the specific "use and maintenance" book-let which is supplied with it).

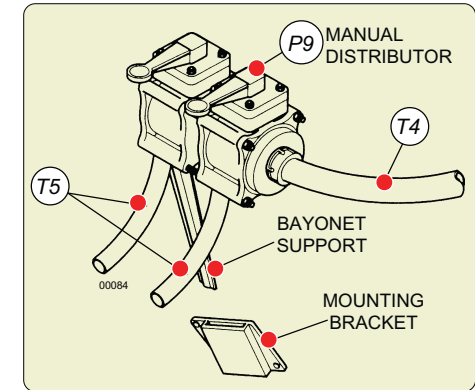

Position the distribution piping T5 and feed piping T4 so as to avoid the risk of suffering damage or breakage during spraying. It may be needed to shorten the pipes.

IN CASE OF BREAKAGE:

- 1 - Stop the tractor and remove the key from the control panel.
- 2 - Close the 2 taps of distributor (P9).
- 3 - Move the 3-way cock (P2) lever to position "3", filling.
- 4 - Close the cock with pressure regulating handgrip (P5) (turn it clockwise).
- 5 - Repair or replace the broken pipes (for the elimination of these parts, please follow the current regulations).

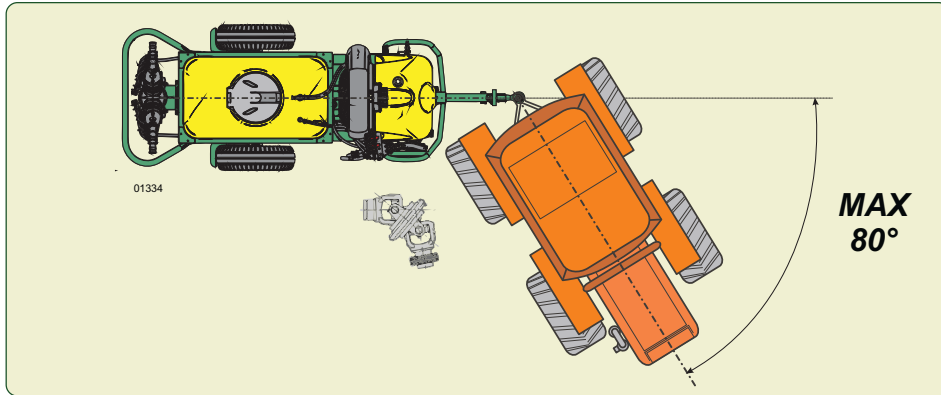

When some curves are carried out with the power takeoff inserted, the steering angle can be 80° max. Beyond such a value, it will be necessary to disengage the power takeoff, in order to avoid any possible breaks and dangers.

**ANYWAY, THE USER HAS BOTH TO FOLLOW AND TO OBSERVE ALL THE INDICATIONS SUPPLIED IN THE USE AND MAINTENANCE BOOKLET PROVIDED BY THE CARDAN SHAFT MANUFACTURER.**

**DEFINITION OF THE TRANSMISSION SHAFT LENGTH.**

1. After having hitched the sprayer to the tractor, set the operative unit to the maximum steering position allowed (without cardan shaft and with PTO disengaged).
2. Measure the distance "D" between the grooves of the two PTOs.

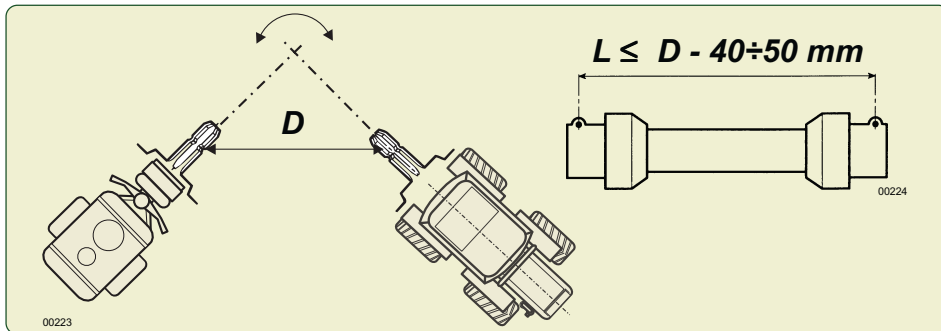

3. Length "L" of the transmission shaft (refer to the picture) to be deployed, measured between the 2 stopping pawls and with joint closed, must be 40±50 mm lesser than distance "D": "L ≤ D - 40±50 mm"

**The homocinetic joint HAS TO BE MOUNTED ON THE TRACTOR PTO. On these conditions, it is possible to carry out curves having a 70/80° steering angle, with the power takeoff turning.**

**5 COUPLING MODALITIES 5**

**5.1- HITCHING TO THE TRACTOR**

- Check that the tractor "permissible trailed weight" is compatible with the sprayer weight, when this is fully loaded and complete with the equipments mounted for the treatment (see the Paragraphs "3.3" - "4.4" as well as the jointed documents).
- THE TRACTOR'S POWER TAKE-OFF (PTO), UNDER ALL UTILISATION CONDITIONS, MUST PROVIDE A POWER EXCEEDING THAT ABSORBED BY THE SPRAYER.

| Pairing suggested for tractors of at least | BLITZ 42 |
|--|----------|
| CV   | 22       |
| kW   | 16       |

TAB\_004

- The hitching has to be carried out on a plane surface with a suitable consistency, after having checked that all the people not charged with the operation moved away, as well as the children and the animals possibly present.
- On-road use is permitted only in accordance with the rules in force in the country of use, without having loaded chemicals in the tank.

**5.1.1 - Sprayer with standard drawbar**

**EXECUTION**

1. Start the tractor and move it near the sprayer and aligned with it.
2. Stop the tractor and remove the key from the control panel.
3. Select the trail eye position: either up or down. The sprayer has to operate as horizontally as possible. If the ground allows it, intervene by regulating also the axle height.
4. Position the drawbar trail eye at the height of the trail fork, by acting on the support foot.

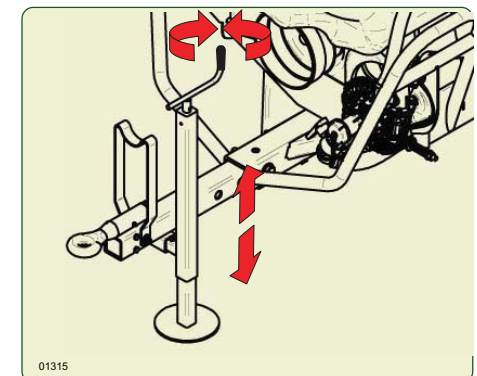

5. Extract the pivot (1) of the tractor hook (4);

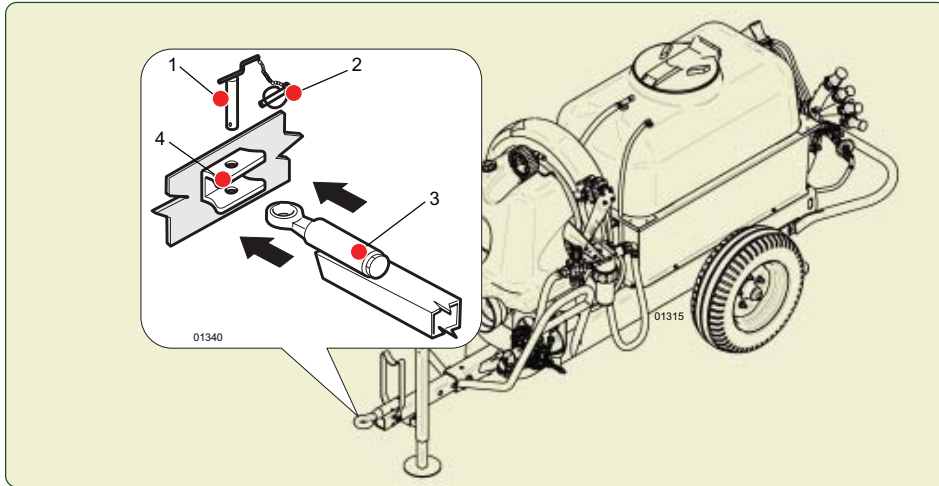

6. Introduce drawbar eye (3) into the traction hook (4) and introduce again the locking pivot (1);
7. Fix the pivot by means of the relevant safety split pin (2);
8. Unscrew and remove the through safety screw (5) and unloose the two lateral screws (6);
9. If necessary, regulate the drawbar length;
10. Introduce and tighten the through safety screw (5) and the relevant self-locking nut. Tighten the two lateral screws (6),

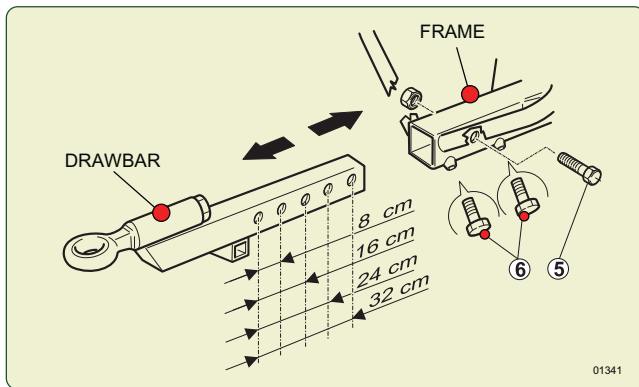

**⚠ After every regulation, carefully tighten the screws and the bolt involved in the carried out operation.**

11. After having properly fastened the fastening bracket supplied with the equipment, place the manual distributor (P9) near the driver.
12. Screw the two feeding pipes to the distribution device (head).

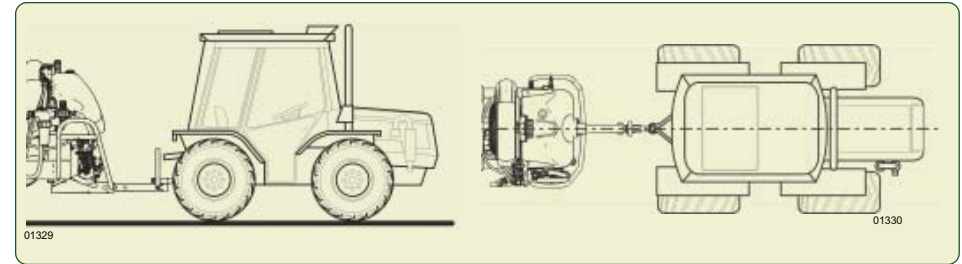

## 5.2 - MOUNTING OF THE TRANSMISSION SHAFT



The mounting, disassembling or possible other interventions on the transmission shaft must be carried out with the engine switched off and with the starter key removed from the tractor's control panel.



**OBSERVE THE REGULATIONS CONTAINED IN THE USE AND MAINTENANCE BOOKLET PROVIDED BY THE SHAFT MANUFACTURER.**

### 5.2.1 - Transmission with a single homocynetic joint (on the tractor side)

The transmission shaft mounting has to be carried out when the 2 PTO are coaxial, or, shouldn't this be possible, when their axes are parallel. In this case, the misalignment has to be such to PREVENT the transmission shaft articulated joints to operate with an angle exceeding a 15° maximum width. Those working positions can be reached by acting on the drawbar, which is adjustable both in height and in length.

