



OPERATION AND MAINTENANCE INSTRUCTIONS

cima[®] S.p.A.

27040 Montù Beccaria - Loc. Molino Quaroni - (PV) - ITALIA
Tel. +39.0385.246636 r.a. - Fax +39.0385.246637
<http://www.cima.it>

cima[®]

atomizzatori e impolveratori

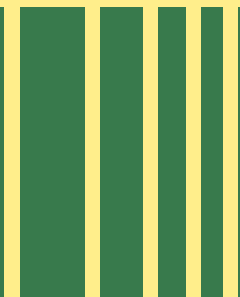

Dear Customer, thank you very much!

We want to congratulate with you, for having chosen a **cima**® sprayer.

Your choice shows the wisdom of the well-informed Purchaser, aware of the fact, that the required features of quality, technique and reliability must be satisfied at the right price!

Our continuous engagement in R&D and in testing our machines allows us to realize products able to offer the best performances, a high reliability and a great easiness of use at the same time !

Our first goal, is to get our Customers happy for having met us!

The "Spare parts catalogue" of this sprayer/sprayhead is available in the "restricted area" on website www.cima.it.

In order to accede, use:

Username: **sprayer**

Password: **844719KE**

Where we are



Warranty conditions

1. Warranty

The goods sold are covered by a general warranty that ensures the good quality of the materials, solid construction and regular operation for twelve months from the date of delivery.

During the warranty period, C.I.M.A. S.p.A. pledges to replace, free of charge, the parts which, in his unquestionable judgement, are considered defective, provided that the flaws and defects cannot be attributed to poor use or maintenance of the product or an unreasonable, inappropriate and unsuitable use of such product with respect to the technical instructions supplied by C.I.M.A. S.p.A. The products which have been modified, repaired, assembled or tampered with by a third party, consumption materials and the parts subject to wear and tear are excluded from the warranty. The replacements will be made free CIMA S.p.A. works and the buyer will be responsible for all shipping and return expenses. The buyer will be responsible for the costs of the labour needed to replace the parts considered defective. The resolution of the contract and any compensation for damage cannot be claimed by the buyer except for serious faults to be proven by said buyer. The warranty will no longer be extended to the buyer if he does not respect the agreed upon payment procedures and terms.

2. Reporting defects in goods

The claims for flaws or defects in the goods shall be submitted within eight days from when such goods are received or from when hidden defects are discovered, in writing, by means of a registered letter.

No claim can be made, nor as an exception, in a court of law if the goods, for which the claim is submitted, have not been regularly paid.

Any claim concerning a single delivery of goods will not exonerate the buyer from his obligation to pick-up the remaining quantity of goods within the limit of the order.

3. To pass safety information

The buyer is responsible towards the final user for the safety information shown on the sale documentation, concerning use limit, performances and product features.

4. Validity and acceptance

The guarantee is valid if the CERTIFICATE OF GUARANTEE is sent, to C.I.M.A. S.p.A., with every part of it filled in, within 30 days from the date of purchase (referring to the date of the postmark).

Informative according to the D. L. n. 196 of the 2003 ("Code in matter of protection of the personal data")

Dear customer,
according to art. 13 of the D.Lgs. 196/03 "Unique Text on Privacy" (referred to as 'Law' here below) we would like to inform you about the following:

- 1) the personal data given to C.I.M.A. S.p.A. when filling in the "Warranty Certificate" will be processed respecting the above mentioned regulations and the rules of privacy stated there in;
- 2) according to art.4, paragraph 1, lett. a) of the Law, the handling of personal data signifies "whatever operation or set of operations carried out (even without the aid of electronic instruments) regarding the collection, recording, organization, conservation, research, handling, modification, selection, extracting of details, comparison of, use of, connecting to, blockage, passing on, distributing, cancellation and destruction of data, even if not recorded in a data bank";

The handling of the personal data given is carried out by automatized and non automatized instruments, with controlled access and as specified by clause B of the Law;

- 3) the data are processed to an institutional end, in connection with or useful to the activities of C.I.M.A. S.p.A. for filing, processing and management;

- 4) the data are collected and recorded so that access is only allowed to authorized persons and they may be processed exclusively by C.I.M.A. S.p.A. to the above mentioned end;

- 5) the collected data may only be given to a third party exclusively in connection with accounting imposed by fiscal law and in the case of demands from the judicial authority.

In addition we inform you that any interested party may exercise his rights mentioned in art.7 of the Law; in the exercise of such rights the interested party may delegate or give a proxy, in writing, to persons or associations. The authority to carry out this processing is C.I.M.A. S.p.A., represented in person by a lawyer.

The data processing is done by instruments fit to guarantee the safety and privacy as specified in clause B of the Law.

Low volume sprayer

SPIDER 50 - 55

Model:

Serial Number:

(Publication N° LUM-SPI-02-EN)

OPERATION AND MAINTENANCE INSTRUCTIONS

© CIMA S.P.A. - 2003-2011 Private property.

Any reproduction, even if partial, is forbidden if not preventively authorized in writing by the Cima S.p.A. company.



CIMA S.p.A. - 27040 Montù Beccaria - Loc. Molino Quaroni - (PV) - ITALIA

Tel. +39.0385.246636 r.a. - Fax +39.0385.246637

<http://www.cima.it>



CERTIFICATE OF WARRANTY

The warranty will not be considered valid if this coupon, with every part of it filled in, is not mailed to the following address: C.I.M.A. S.p.A. - 27040 Montù Beccaria, Loc. Molino Quaroni - (PV) - Italy), or sent by fax to the following number: +39.0385.246637, within 30 days from the date of purchase.

Last name, Name or
NAME OF THE FIRM

ADDRESS

Place PROVINCE ZIP

e.mail (*) telephone (*)

Date of purchase INVOICE N.

MACHINE MOD. MATRICULATION N.

SPRAYHEAD MOD.

Dealer's stamp (compulsory)

(*) NOT COMPULSORY DATA

PRIVACY

Consent for the personal data processing– **PROTECTION OF THE PRIVACY** .
I authorize you, according to the D.Lgs. 196/03 "Consolidated Text about the Privacy" to the processing of my personal data in observance of the law above mentioned, for the indicated purposes, and so that they can be communication to the subjects for the declared purposes.

Date Signature

cut along the dotted line

Warranty conditions

1. Warranty

The goods sold are covered by a general warranty that ensures the good quality of the materials, solid construction and regular operation for twelve months from the date of delivery.

During the warranty period, C.I.M.A. S.p.A. pledges to replace, free of charge, the parts which, in his unquestionable judgement, are considered defective, provided that the flaws and defects cannot be attributed to poor use or maintenance of the product or an unreasonable, inappropriate and unsuitable use of such product with respect to the technical instructions supplied by C.I.M.A. S.p.A. The products which have been modified, repaired, assembled or tampered with by a third party, consumption materials and the parts subject to wear and tear are excluded from the warranty. The replacements will be made free CIMA S.p.A. works and the buyer will be responsible for all shipping and return expenses. The buyer will be responsible for the costs of the labour needed to replace the parts considered defective. The resolution of the contract and any compensation for damage cannot be claimed by the buyer except for serious faults to be proven by said buyer. The warranty will no longer be extended to the buyer if he does not respect the agreed upon payment procedures and terms.

2. Reporting defects in goods

The claims for flaws or defects in the goods shall be submitted within eight days from when such goods are received or from when hidden defects are discovered, in writing, by means of a registered letter.

No claim can be made, nor as an exception, in a court of law if the goods, for which the claim is submitted, have not been regularly paid.

Any claim concerning a single delivery of goods will not exonerate the buyer from his obligation to pick-up the remaining quantity of goods within the limit of the order.

3. To pass safety information

The buyer is responsible towards the final user for the safety information shown on the sale documentation, concerning use limit, performances and product features.

4. Validity and acceptance

The guarantee is valid if the CERTIFICATE OF GUARANTEE is sent, to C.I.M.A. S.p.A., with every part of it filled in, within 30 days from the date of purchase (referring to the date of the postmark).

Informative according to the D. L. n. 196 of the 2003 ("Code in matter of protection of the personal data")

Dear customer,
according to art. 13 of the D.Lgs. 196/03 "Unique Text on Privacy" (referred to as 'Law' here below) we would like to inform you about the following:

- 1) the personal data given to C.I.M.A. S.p.A. when filling in the "Warranty Certificate" will be processed respecting the above mentioned regulations and the rules of privacy stated there in;
- 2) according to art.4, paragraph 1, lett. a) of the Law, the handling of personal data signifies "whatever operation or set of operations carried out (even without the aid of electronic instruments) regarding the collection, recording, organization, conservation, research, handling, modification, selection, extracting of details, comparison of, use of, connecting to, blockage, passing on, distributing, cancellation and destruction of data, even if not recorded in a data bank";

The handling of the personal data given is carried out by automatized and non automatized instruments, with controlled access and as specified by clause B of the Law;

- 3) the data are processed to an institutional end, in connection with or useful to the activities of C.I.M.A. S.p.A. for filing, processing and management;

- 4) the data are collected and recorded so that access is only allowed to authorized persons and they may be processed exclusively by C.I.M.A. S.p.A. to the above mentioned end;

- 5) the collected data may only be given to a third party exclusively in connection with accounting imposed by fiscal law and in the case of demands from the judicial authority.

In addition we inform you that any interested party may exercise his rights mentioned in art.7 of the Law; in the exercise of such rights the interested party may delegate or give a proxy, in writing, to persons or associations. The authority to carry out this processing is C.I.M.A. S.p.A., represented in person by a lawyer.

The data processing is done by instruments fit to guarantee the safety and privacy as specified in clause B of the Law.

LISTING OF VALID PAGES

This publication consists of 66 pages, subdivided as follows:

N° OF PAGE	REVISION	BASE
from I to VI	02	August 2011
from 1 to 60	02	August 2011

ADDITIONAL RECORDS AND VARIANTS

REVISION	DESCRIPTION
00	First Edition, April 2003
01	Second Edition, June 2007
02	Third edition, August 2011
03	
04	
05	
06	
07	
08	

GENERAL INDEX

1	FOREWORD	1
1.1	CHECKS TO BE CARRIED OUT AT MATERIAL RECEPTION	1
1.2	PUBLICATION IDENTIFICATION	1
1.3	ATTACHED PUBLICATIONS	1
1.4	PURPOSE OF PUBLICATION	1
1.5	REFERENCE TO REGULATIONS	1
1.6	USING THE MANUAL	2
1.7	UPDATES	2
2	GLOSSARY	3
2.1	TERMINOLOGY	3
2.2	ABBREVIATIONS	3
2.3	DECALS	3
3	GENERAL INFORMATION	7
3.1	MACHINE IDENTIFICATION	7
3.2	TECHNICAL ASSISTANCE	8
3.3	SAFETY NOTICES	8
3.3.1	General	8
3.3.2	Precautions against the fires	9
3.4	SAFETY SYSTEMS	10
3.5	HANDLING OF AGRO-CHEMICALS	11
3.5.1	Storage	11
3.5.2	Specific equipment	11
3.5.3	Disposal of empty containers and agro-chemical residues	11
3.5.4	Personal means of protection	12
4	MACHINE'S STRUCTURAL ANALYSIS	13
4.1	FRAME	15
4.2	FAN SERVO AMPLIFIER	15
4.4	HYDRAULIC CIRCUIT COMPONENTS	16
4.5	TECHNICAL DATA	27
4.5.1	Sprayers dimensions and weights	27
4.5.2	Fan and pump - Technical Data	28
4.5.3	Centrifugal pump CD 32	28
5	COUPLING MODALITIES	29
5.1	INSTALLATION ON THE GRAPE HARVESTER	29

CERTIFICATE OF WARRANTY

Copy for the owner (to be kept in the manual "Instructions for the use and maintenance")

Last name, Name or
NAME OF THE FIRM

ADDRESS

Place PROVINCE ZIP

e.mail (*) telephone (*)

Date of purchase INVOICE N.

MACHINE MOD. MATRICULATION N.

SPRAYHEAD MOD.

Dealer's stamp (compulsory)

(*) NOT COMPULSORY DATA

PRIVACY

Consent for the personal data processing– **PROTECTION OF THE PRIVACY .**

I authorize you, according to the D.Lgs. 196/03 "Consolidated Text about the Privacy" to the processing of my personal data in observance of the law above mentioned, for the indicated purposes, and so that they can be communication to the subjects for the declared purposes.

Date Signature

13	FAULTS FINDING	50
14	REPAIRS ALLOWED	52
14.1	REPLACEMENT OF PUMP CONTROL BELT	52
14.2	REPLACEMENT OF ELECTRICAL PANEL'S FUSES	53
14.3	PRESSURE GAUGE REPLACEMENT	53
14.4	INSPECTION AND CLEANING PUMP FILTER	54
14.5	CHECK HYDRAULIC DELIVERY	55
15	INTEGRATIVE DIAGRAMS	56
15.1	HYDRO-PNEUMATIC DIAGRAM	56
15.2	WIRING DIAGRAM	57
16	NOISE LEVEL	58
17	ATTACHMENT: DECLARATION OF CONFORMITY	86
18	WARRANTY	87
18.1	WARRANTY	87
18.2	REPORTING DEFECTS IN GOODS	87
18.3	TO PASS SAFETY INFORMATION	87
18.4	VALIDITY AND ACCEPTANCE	87

NOTES

.....

.....

.....

.....

.....

.....

.....

.....

.....

.....

.....

.....

.....

.....

.....

.....

.....

.....

.....

.....

.....

.....

.....

.....



THE OWNER AND/OR THE OPERATOR OF THE SPRAYER ARE NOT PERMITTED TO MODIFY THE STRUCTURE OR THE SPECIFIC OPERATION OF THE SPRAYER ITSELF. ANY REPAIRING INTERVENTION HAS TO BE CARRIED OUT EITHER AT THE DEALERS' OR AT THE C.I.M.A. S.p.A. AUTHORIZED WORKSHOPS, OTHERWISE ANY KIND OF WARRANTY IMMEDIATELY CEASES AND C.I.M.A. S.p.A. IS CLEARED OF ANY CONSEQUENT AND/OR IMPLIED RESPONSIBILITY.

18.1 - Warranty

The goods sold are covered by a general warranty that ensures the good quality of the materials, solid construction and regular operation for twelve months from the date of delivery.

During the warranty period, C.I.M.A. S.p.A. pledges to replace, free of charge, the parts which, in his unquestionable judgement, are considered defective, provided that the flaws and defects cannot be attributed to poor use or maintenance of the product or an unreasonable, inappropriate and unsuitable use of such product with respect to the technical instructions supplied by C.I.M.A. S.p.A.

The products which have been modified, repaired, assembled or tampered with by a third party, consumption materials and the parts subject to wear and tear are excluded from the warranty.

The replacements will be made free CIMA S.p.A. works and the buyer will be responsible for all shipping and return expenses.

The buyer will be responsible for the costs of the labour needed to replace the parts considered defective. The resolution of the contract and any compensation for damage cannot be claimed by the buyer except for serious faults to be proven by said buyer.

The warranty will no longer be extended to the buyer if he does not respect the agreed upon payment procedures and terms.

18.2 - Reporting defects in goods

The claims for flaws or defects in the goods shall be submitted within eight days from when such goods are received or from when hidden defects are discovered, in writing, by means of a registered letter. No claim can be made, nor as an exception, in a court of law if the goods, for which the claim is submitted, have not been regularly paid.

Any claim concerning a single delivery of goods will not exonerate the buyer from his obligation to pick-up the remaining quantity of goods within the limit of the order.

18.3 - To pass safety information

The buyer is responsible towards the final user for the safety information shown on the sale documentation, concerning use limit, performances and product features.

18.4 - Validity and acceptance

The guarantee is valid if the CERTIFICATE OF GUARANTEE is sent, to C.I.M.A. S.p.A., with every part of it filled in, within 30 days from the date of purchase (referring to the date of the postmark).

1.1 - CHECKS TO BE CARRIED OUT AT MATERIAL RECEPTION

At reception of the machine, make sure that this one is complete and in good condition in every part. If any damaged parts are found out, timely inform about that the machine Distributor, or directly contact C.I.M.A. SpA.

Upon receipt of the machine, expressly verify the following conditions:

- that the machine is delivered assembled in all its parts, and that the equipment fully complies with the requested configuration (that procedure is necessary, because for overall dimensions' requirements the machine is often partially disassembled during the transport);
- that the connections are correctly mounted;
- that the cable clamps are correctly tightened, as well as all the fittings and connections;
- that all the protections are both present and firmly fastened;
- that the oil level inside the fan support is correct;
- that the fan, the fan protection casing or other parts of the machine ARE NOT damaged because of any bumps suffered during the transport.

1.2 - PUBLICATION IDENTIFICATION

The "OPERATION AND MAINTENANCE INSTRUCTIONS" manual is an integrative part of the sprayers. It is identified by a Publication No. located on the frontispiece, and through which the document can be identified, traced and/or subsequently referred to.

The information elements contained herein are updated as at the date of publication. C.I.M.A. S.p.A. reserves the right to modify its machines without notice, with the purpose of applying technical enhancements, and it declines all responsibility for possible omissions from the publication. All rights reserved. No parts of this book may be reproduced or utilized in any form or by any means, electronic or mechanical, including photocopying, recording, or by any information storage and retrieval system, without premission in writing by C.I.M.A. S.p.A.

1.3 - ATTACHED PUBLICATIONS

- Spare parts catalogue;
- "Low Volume - Instructions for sprayer adjustment"

1.4 - PURPOSE OF PUBLICATION

All indications contained in this manual are aimed at the user of the sprayer.

The duration of the machine and its operation, the operator's safety and the respect for the environment are dependent upon scrupulous observance of the stated norms.

Before making use of the sprayer, the user must read, understand and abide by all regulations listed in this manual.

1.5 - REFERENCE TO REGULATIONS

This manual was set out conforming to the regulations contained in following documents:

- Directive 2006/42/CE: Attachment 1 point 1.7.4;
- UNI 10653: Technical Documentation;
- UNI 10893: Technical Documentation.

1.6 - USING THE MANUAL

Read every part of this manual, paying attention to the **WARNING** and **DANGER** indications both on the text and on the machine or on components.

All operations suggested by the manual will have to be followed with the utmost care and only after having understood the negative consequences of improper usage.

The following “**symbols**” are used within the text in order to highlight and visually identify the importance of the various types of information:



Indicates important additional information



Non observance can result in permanent damage to the sprayer.



Highlights possibly dangerous situations to people.

The manual, with relevant attachments and possible integrating issues, must be kept with the utmost care and must always be complete, integer and legible in every part. Should it be mislaid it is imperative to immediately request a duplicate from C.I.M.A. S.p.A. Should the decals originally applied on the machine be mislaid, damaged or become incomprehensible, they should be promptly replaced.

For every type of distribution device (Head) delivered with the sprayer, a specific user and maintenance manual is attached. All the head manuals must always accompany the one of the machine.



- The manual must always be kept for the sprayer's whole operational life.
- Any modification received must be permanently inserted in this publication.
- The manual must be ceded with the sprayer should this be sold.

1.7 - UPDATES

Possible updates that C.I.M.A. S.p.A. will provide the owner of the sprayer will be accompanied by instructions to insert in this publication.

Should the machine be sold, the owner must inform the new purchaser that he should notify C.I.M.A. S.p.A. of his address in order to receive possible future integrating issues and/or updates.

17 ATTACHMENT : DECLARATON OF CONFORMITY 17

DICHIARAZIONE DI CONFORMITÀ ai sensi della direttiva 98/37/CE del 22/06/98 e successive modificazioni		CE
DECLARATION OF CONFORMITY as directive: 98/37/CE - 22/06/98 and subsequent modifications	DECLARATION DE CONFORMITE selon la directive 98/37/CE - 22/06/98 et modifications ultérieures	CE
ÜBERREINSTIMMUNGS-ERKLÄRUNG lt. Direktiven 98/37/CE - 22/06/98 und nachfolgenden Änderung	DECLARACION DE CONFORMIDAD con arreglo a la Directiva 98/37/CE - 22/06/98 y modificaciones siguientes	CE

CIMA s.p.a. 27040 MONTÙ BECCARIA (PV) - ITALY - Loc. Molino Quaroni

DICHIARA SOTTO LA PROPRIA RESPONSABILITÀ CHE LA MACCHINA:	HEREWITH DECLARES UNDER THEIR PERSONAL RESPONSABILITY THAT THE FOLLOWING MACHINE:	DECLARONS SOUS NOTRE RESPONSABILITÉ QUE LA MACHINE DÉCRITE CI-APRÈS:	BESTÄTIGT HERMIT UNTER IHRER PERSONLICHEN VERANTWORTUNG DAS DIE MASCHINE:	DECLARA BAJO LA PROPIA RESPONSABILIDA QUE LA MAQUINA:
--	---	---	---	--

SERIE, TIPO - MODEL. TYPE - SERIE, TYPE - MODEL, TYP - SERIE, TIPO:

MATRICOLA - SERIAL - MATRICULE - SERIAL - MATRICULA NR.:

E' conforme ai Requisiti essenziali di Sicurezza e di Tutela della Salute di cui alla Direttiva 98/37/CE del 22/06/98 e sue successive modificazioni.
 Per la verifica della Conformità di cui alle Direttive sopra menzionate, sono state consultate le seguenti:
 Norme armonizzate: EN 294 EN 349 EN 907.

Conforms to the essential Safety regulation as well as the Health requirements as per European Economic Community Directive: 98/37/CE - 22/06/98 and subsequent modifications. For the verification of conformity as per above mentioned directives the following official EN norms have been consulted: Harmonized norms: EN 294 EN 349 EN 907.	Est conforme aux exigences de Sécurité et de Sauvegarde de la Santé dont à la Directive 98/37/CE - 22/06/98 et modification ultérieures. Pour vérifier la conformité aux directives susmentionnées, ont été prises en compte les normes suivantes: Normes harmonisées: EN 294 EN 349 EN 907.
Stimmt mit den wesentlichen Requisiten der Sicherheitsvorschriften und der Gesundheitsvorsorge lt. EWG Direktive Nr. 98/37/CE - 22/06/98 und nachfolgenden Änderungsüberein. Für die Überprüfung dieser Übereinstimmungs-Erklärung lt. obigen Direktiven sind folgende Normen konsultiert worden: Normen: EN 294 EN 349 EN 907.	Cumple con los requisitos esenciales de Seguridad y de Preservación de la Salud contenidos en la Directiva 98/37/CE - 22/06/98 y modificaciones siguientes. Para comprobar la conformidad a la que se refieren las Directivas anteriormente citadas, se han consultado las siguientes: Normas Armonizadas: EN 294 EN 349 EN 907.

Responsabile della Sicurezza - The Security Official - Responsable Sécurité et Homologations - Der Sicherheits-Beamter - Responsable de la Seguridad

Smeraldi Paolo

Montù Beccaria (PV)
 Data, Date, Date, Datum, Fecha, _____

Observed equivalent average level: L qA - 93,0 ± 0.2 dB(A)

2.1 - TERMINOLOGY

The terms FRONT, REAR, RIGHT and LEFT utilised in this publication refer to the sprayer as seen by an operator from behind the operative unit along the drive line and facing it: **the rear part** of the machine is that closest to the operator, and is where the distribution device (Head) is mounted - and **the front part** is the opposite one

2.2 - ABBREVIATIONS

cm	centimetres
g	grams
h	hour
ha	hectare
ha/h	hectare per hour
l	litres
l/h	litres per hour
l/min	litres per minute
kg	kilogram
kg/cm ²	kilograms per square centimeter (atmosphere)
km	kilometre
km/h	kilometres per hour
Lm	width in metres
m	metre
Mesh	N° of meshes per linear inch
Micron	1/1000 of millimetre
mm	millimetres
PTO	power take-off
RPM	revs per minute
s	seconds

2.3 - DECALS

The safety and use/maintenance decals applied to the machine are described in the following paragraph.



Every decal is marked with its part number, in case it needs to be replaced.

Safety

- 1 - 95001 - **STOP THE ENGINE AND REMOVE THE KEY FROM THE TRACTOR'S CONTROL PANEL BEFORE CARRYING OUT ALL MAINTENANCE OR REPAIR OPERATIONS.**
- **CONSULT THE USER AND MAINTENANCE MANUAL BEFORE USING OR INTERVENING ON THE MACHINE**
- Positioned on the protection cover for fan servo amplifier.

- 2 - 95098 - **CONSULT THE USER AND MAINTENANCE MANUAL BEFORE USING THE MACHINE**
 - DANGER OF CONTAMINATION BY CONTACT OR POISONOUS PRODUCTS INHALATION
 - IT IS FORBIDDEN TO ENTER INTO THE TANK!
 - (2) Positioned on the tank, near the main filler.
- 3 - 95005 - **DANGER, PARTS IN MOTION. BEFORE REMOVING PROTECTION GUARDS, STOP THE TRACTOR, REMOVE THE KEY FROM THE TRACTOR'S CONTROL PANEL AND ENSURE THAT ALL MOVING PARTS HAVE STOPPED**
 - Positioned on the fan casing next to the outflow vent.
- 4 - 95015 - **BEFORE UTILISING THE RELEASE DEVICE, STOP THE TRACTOR, REMOVE THE KEY FROM THE TRACTOR'S CONTROL PANEL AND ENSURE THAT THE FAN HAS STOPPED**
 - Positioned in the forward part of the protection cover for fan servo amplifier (*).
- 5 - 95010 - **MAXIMUM OPERATING SPEED OF THE DRIVE OUTLET (PTO): 540 RPM**
 - Positioned on the lower part of the machine, on the protection cover for fan servo amplifier, under the hydraulic motor.
- 6 - 95009 - **DANGER: GLOVES MUST BE USED TO EMPTY THE TANK**
 - (2) Positioned on the frame lower part, right and left side, near the discharge lever tap.

(*) = For versions in which this is envisaged

Use and maintenance

- 7 - 95059 - **HOOKING POINT FOR THE LIFTING OF THE MACHINE**
 - (2) Positioned on the upper crosspiece of the frame.
- 8 - 95079 - **CHECK THE OIL LEVEL EVERY 8 HOURS: FAN SHAFT BEARINGS**
 - Positioned on the chassis, over the fan casing.
- 9 - 95054 - **GREASE EVERY 200 HOURS: FAN TIGHTENER SUPPORT**
 - Positioned on the chassis, in the low, rear side, on the left.
- 10 - 95065 - **WARNING: NEVER OPERATE THE SPRAYER WITHOUT LIQUID IN THE TANK**
 - (3) Positioned on the tank, near the main filler and on the electrical control unit.
- 11 - 95088 - **INDICATION ON THE OPERATION OF THE WORKING/CLEANING TAPS**
 - (2) Positioned on the lower side of the frame, left and right-hand side, next to the taps.

15.2 - WIRING DIAGRAM

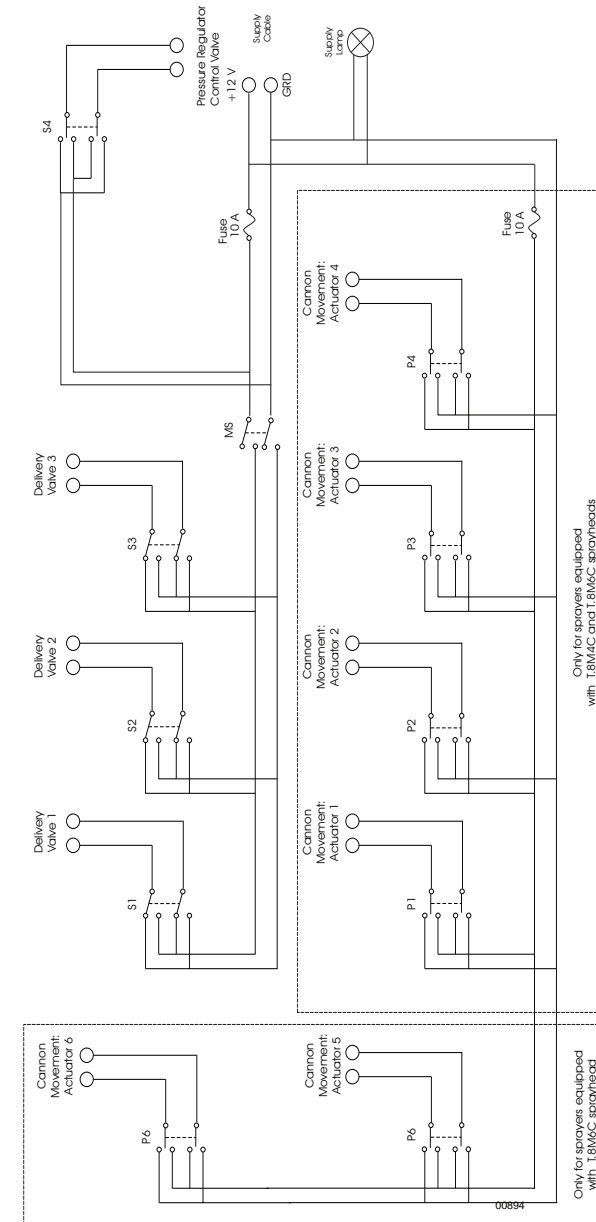

Wiring diagram of electric control unit

15 INTEGRATIVE DIAGRAMS 1 5

15.1 - HYDRO-PNEUMATIC DIAGRAM

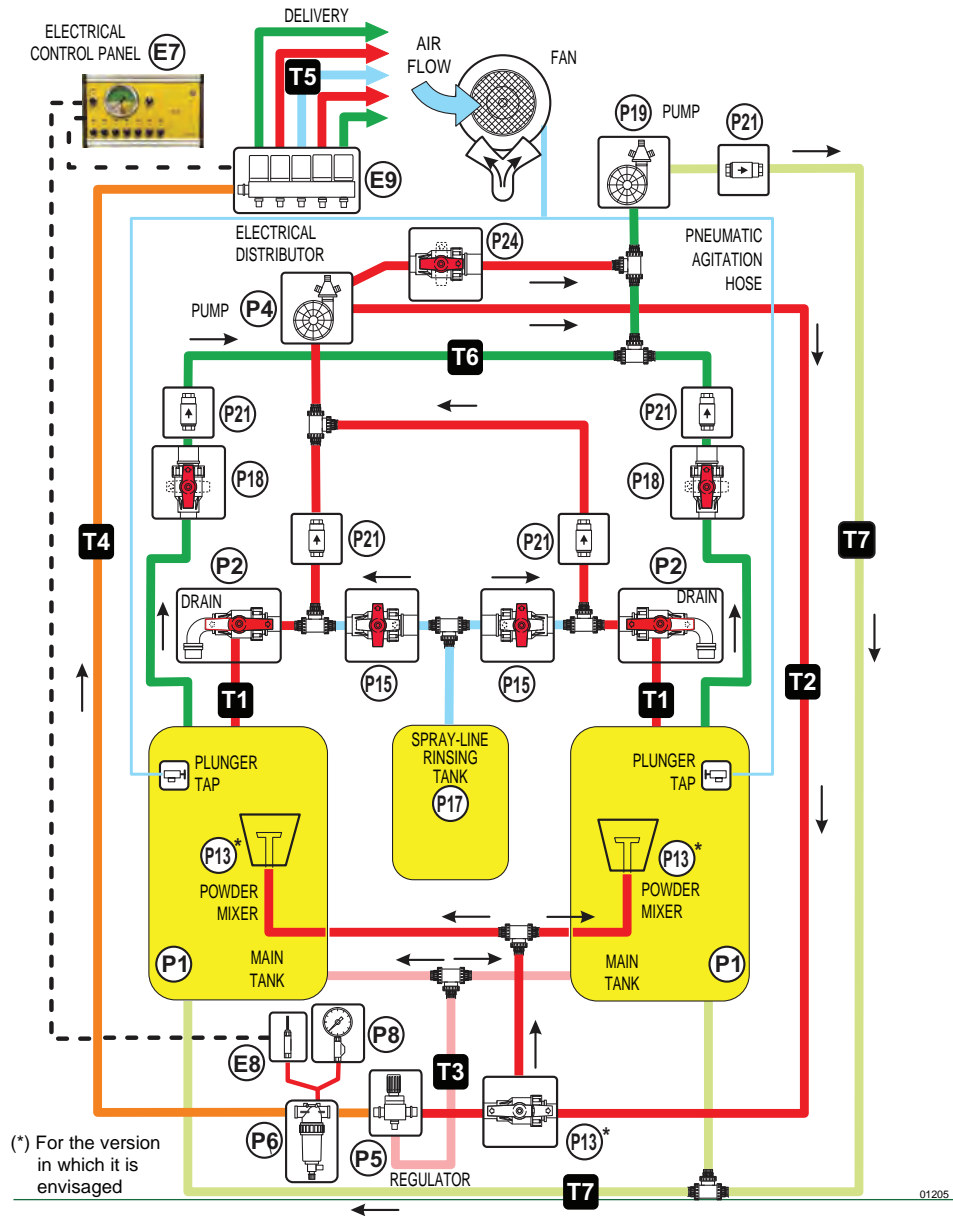

Positioning of the safety, use and maintenance decals



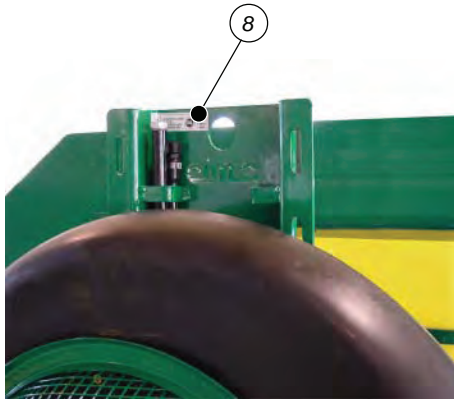

00810

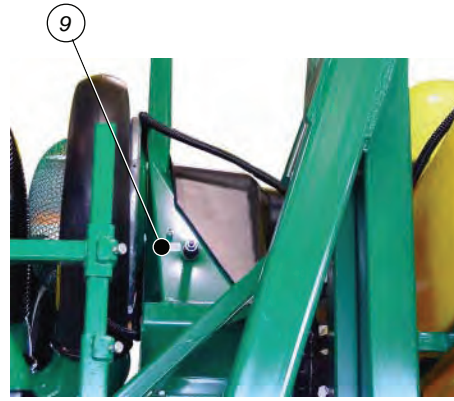

01209

* Safety decals



1 95001



2 95098



3 95005



4 95015 (*)



5 95010



8 95009

14.5. - CHECK HYDRAULIC DELIVERY



TESTING OF HYDRAULIC DELIVERY MUST BE MADE WITH THE SPRAYER ON A FLAT SURFACE. THE PROOF IS IN THE DETECTION OF TIME TO PROVIDE A KNOWN QUANTITY CONTENT OF LIQUID IN TANK

1. Disengage the fan (for versions where it is foreseen): see Paragraph 8.1.a.
2. Close the taps of the 2-way distributor:
 - a. if manual (P9), the levers are to be lowered (horizontally positioned);
 - b. if electric, position to "OFF" the quick-break switches (E10).
3. Fill the tank with about 250 liters of clean water (USED AS REFERENCE THE MARK OF LEVEL INDICATOR ON THE TANK - see Paragraphs 8.2/8.3).
4. Engage the fan (for versions where it is foreseen): see Paragraph 8.1.b.



The claimed performance is obtained with the PTO at 540 rpm. and with the fan running .

For correct verification result this condition MUST ALWAYS BE RESPECTED.

5. Bring the PTO to 540 rpm rotation rate.
6. Open the taps of the 2-way distributor:
 - a. if manual (P9), the levers are to be raised (vertically positioned);
 - b. if electric, position to "ON" the quick-break switches (E10).
7. Regulate the operating pressure, by acting on the pressure regulator (P5) (or electric E5) with the distributor, hand (P9) or electric (E9), open (DISTRIBUTION) and regulate the position of calibration disc (P11) in accord to "Delivery chart" relating to the sprayhead used.
8. Close the taps of the 2-way distributor:
 - a. if manual (P9), the levers are to be lowered (horizontally positioned);
 - b. if electric, position to "OFF" the quick-break switches (E10).
9. Add water to the tank until you reach the mark of 300 liters (reference).
10. Add additional 25 liters of water to the tank, the quantity required for the verification flow, using a graduated container or by weighing the amount payable (1liter = 1 kg).
11. Open the taps of the 2-way distributor (manual or electric) to start delivery.
12. Continue the delivery until the water reaches the mark 300 liters on the level indicator.



NOTED THE TIME ELAPSED BETWEEN THE RELEASE DELIVERY AND THE ACHIEVEMENT OF MARK 300 LITERS.

13. Apply the formula:
$$Q = \left(\frac{60}{t} \right) \times 25$$
 where: **Q**, is the hourly delivery detected (lt./h);
t, is the time measured in minutes and seconds (centesimal)

TESTING IS CONSIDERED WITH POSITIVE RESULTS (machine properly calibrated) WHEN THE VALUE CALCULATED "Q" IS INDICATED ON THE "DELIVERY CHART" WITH A TOLERANCE OF ± 2.5%.

In case of different values to verify the efficiency of the pipe, the fittings, the pressure gauge and the proper positioning of the calibration discs (P11), if necessary replace the damaged or defective, and the test repeated.

14.4. - INSPECTION AND CLEANING PUMP FILTER



The pump is provided by the suction side of a filter to prevent the accidental entry of foreign bodies in the pump body, such a possibility does not constitute a hazard and can only cause damage to the impeller shown by a drop in pressure reported by gauge.

The clogging of the filter pump causing an immediate lowering of pressure delivery. If necessary check the cleanliness of the filter:

Main pump

1. Verify that the lever of the cock (P15) it's in position "1" - WORKING.
2. Position the lever cock (P2) to "2"- WASHING.
3. Close the cock (P24): position "c".
4. Unscrew the plug (1) and eventually remove the foreign body present in to the filter.
5. If necessary, unscrew the nuts (2) and remove the filter (4), to clean completely.
6. Replace the filter by paying attention to the conditions and the proper placement of the O.Ring (5).
7. Close the screw plug (1).
8. Open the cock (P24): position "a".
9. Position the lever cock (P2) to "1" - WORKING.

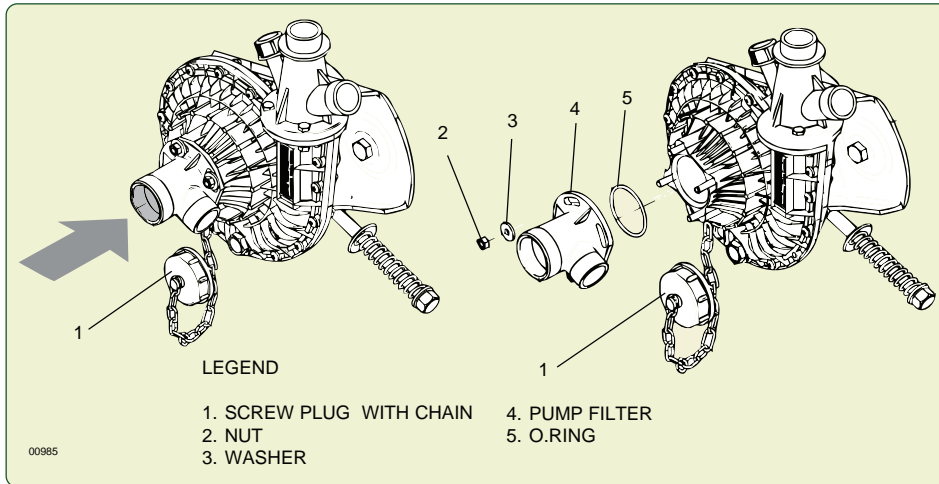

Additional agitation pump

1. Close the cock (P18): position "c".
2. Unscrew the plug (1) and eventually remove the foreign body present in to the filter.
3. If necessary, unscrew the nuts (2) and remove the filter (4), to clean completely.
4. Replace the filter by paying attention to the conditions and the proper placement of the O.Ring (5).
5. Close the screw plug (1).
6. Open the cock (P18): position "a".

* Use and maintenance decals

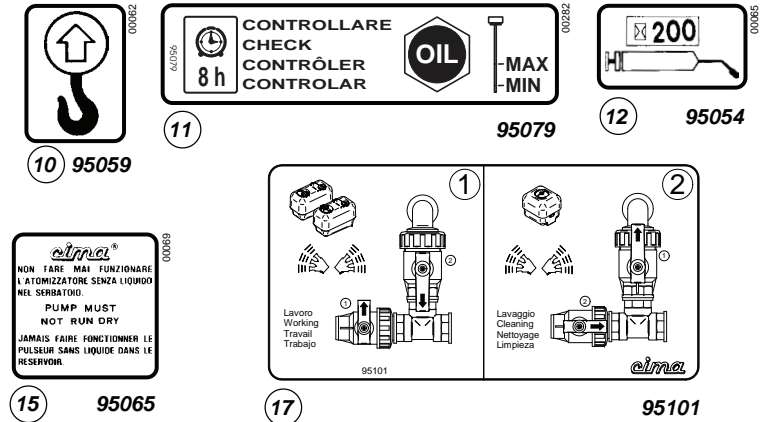

3 GENERAL INFORMATION 3

3.1 - MACHINE IDENTIFICATION



Sprayer identification nameplate





Frame identification nameplate



3.2 - TECHNICAL ASSISTANCE

C.I.M.A. S.p.A. is at the complete disposal of customers for any type of intervention. The names and addresses of its service network, both in Italy and in foreign countries, can be requested from:

C.I.M.A. S.p.A. - 27040 Montù Beccaria - Loc. Molino Quaroni (PV) - ITALIA
 tel. +39-0385-246636 - fax +39-0385-246637
 e.mail service@cima.it

3.3 - SAFETY NOTICES

3.3.1 - General



The personnel appointed to the use of the machine must have acquired an exhaustive knowledge of the same one and of the dispositions contained inside this publication, be able to properly interpret the symbols of the adhesives applied on the machine, and, in addition, perfectly know the safety and the work hygienic rules in force in the country where the machine itself is to be used.

All the preparation, use, maintenance, moving and transporting operations must be carried out of the regulations contained in this publication.



IT IS FORBIDDEN TO UTILISE THE SPRAYER FOR PURPOSES OTHER THAN FOR ITS INTENDED USE, SINCE IT WAS MANUFACTURED ONLY FOR SPRAYING AGRICULTURAL CROPS WITH ANTI-PARASITIC PRODUCTS.



When the atomizer assembled, **ALWAYS** check that the load distribution on the front and rear axles of the harvester falls into the limits provided by the "Operation and Maintenance Instructions" manual of the harvester itself.



On the identification plate, the full-load weight (PESO T.) of the machine is indicated, measured **WITHOUT** the distribution device. In order to calculate the weight on the hoister in operative conditions (at full load), add to the weight indicated on the identification plate (PESO T.), the weight of the distribution device which is used (see Par. 4.5.1.).

14.2. - REPLACEMENT OF ELECTRICAL PANEL'S FUSES



Stop the engine and remove the ignition key from the grape harvester's control panel.

1. Remove the rubber protection from the fuse.
 2. SReplace the faulty fuse and install the rubber protection.
- * **Fuse:** **10A solenoid valve**
10A electric actuators for opening/closing head arms
 (only for sprayers equipped with T.8M4C and T8M6C spraheds).



ANY OTHER INTERVENTION HAS TO BE CARRIED OUT AT A C.I.M.A. CUSTOMERS' SERVICING CENTER.

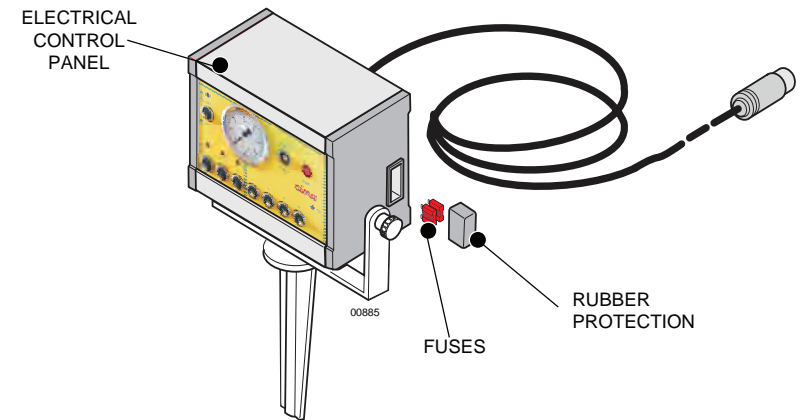

14.3. - PRESSURE GAUGE REPLACEMENT



Stop the engine and remove the ignition key from the grape harvester's control panel.

1. Remove the rubber protection (1).
2. Unscrew and remove the defective pressure gauge.
3. Replace the pressure gauge and reposition the rubber protection.



ANY OTHER INTERVENTION HAS TO BE CARRIED OUT AT A C.I.M.A. CUSTOMERS' SERVICING CENTER.

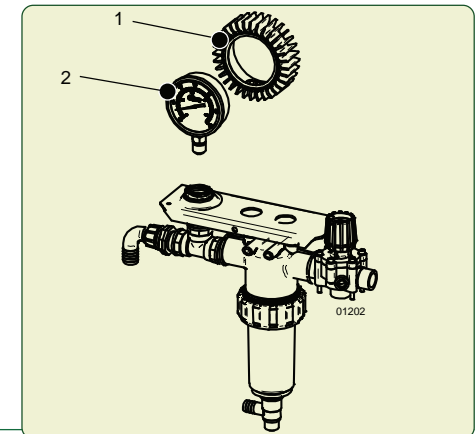



THE OWNER AND/OR THE OPERATOR OF THE SPRAYER ARE NOT PERMITTED TO MODIFY THE STRUCTURE OR THE SPECIFIC OPERATION OF THE SPRAYER ITSELF. ANY REPAIRING INTERVENTION HAS TO BE CARRIED OUT EITHER AT THE DEALERS' OR AT THE C.I.M.A. S.p.A. AUTHORIZED WORKSHOPS, OTHERWISE ANY KIND OF WARRANTY IMMEDIATELY CEASES AND C.I.M.A. S.p.A. IS CLEARED OF ANY CONSEQUENT AND/OR IMPLIED RESPONSIBILITY.

14.1 - REPLACEMENT OF PUMP CONTROL BELT



Stop the engine and remove the key from the grape harvester's control panel.

1. Remove the fan assembly protection, by unscrewing the screw fastening it to the frame.
2. Completely unscrew the tightener spring adjusting screw: the pump support plate will so freely turn.
3. Remove the worn out belt, by getting it first loose from the pump pulley and then from the upper control pulley.
4. Insert the belt first into the race of the upper pulley and then into the race of the pump pulley.
5. Reinstall the spring of the belt-tensioner according to the suggested tensioning conditions.
6. Mount back the fan assembly protection casing.

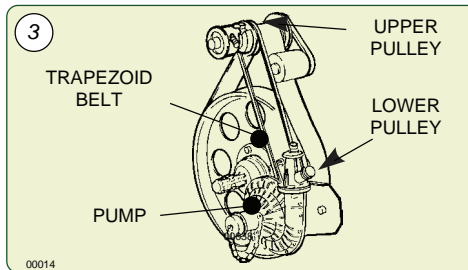
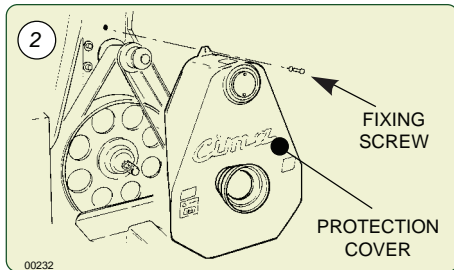
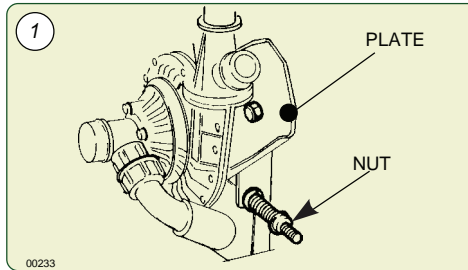

Carefully tighten the screws that were undone during the belt replacement.

It is necessary to scrupulously abide by the following general norms:

- check that the power of the tractor is compatible with the sprayer to be used;
- before utilisation, check the correct tightening and securing of the machine's various components, paying particular attention to the safety protections and to the moving parts;
- keep people and animals away from the machine before starting it up;
- It is forbidden to stand on sprayer platforms while working;
- don't wear articles of clothing that might get caught in moving parts;
- keep to a low speed while negotiating bumps or crossing ditches;
- During the service the operator needs visibility on working areas, it is required to keep properly clean and efficient the cab glass and the driving mirrors;
- always stop the tractor's engine and actuate the parking brake before carrying out any operation on the sprayer;
- never leave the machine unguarded, when the key is inserted inside the tractor control panel;



- **All maintenance and repair operations must be carried out only after having rinsed the tank and flushed the system.**
- **Before operating within the tank it is necessary to wash it thoroughly with clean water.**
- **The application of paints and/or solvents, the washing of closed environments and machinery as well as the utilisation of the air flow for purposes other than those expressly concerning the spraying of agro-chemicals is not permitted.**
- **It is forbidden to enter the tank.**

3.3.2 - Precautions against the fires

Don't approach either flames or heat sources to the machines. The materials used for manufacturing the machine itself are widely made by oil derivatives: tanks, pipes, tyres, plastic components; besides, the presence of lubricants and of chemical product residuals make them potentially flammable.



- **It is forbidden to carry out weldings, if ammonium salts have been used.**
- **It is forbidden to use the machine within a potentially explosive environment.**

3.4 - SAFETY SYSTEMS

All machine moving parts are suitably protected by guards and highlighted through the use of warning decals.



- It is forbidden to use the machine with these guards removed.
- Before removing the protection, stop the tractor's engine and remove the key from the control panel.

The pictures illustrate the machine's guarded parts:

REMOVABLE PROTECTION COVER FOR THE FAN SWITCHING-OFF DEVICE

PROTECTION COVER FOR FAN SERVO AMPLIFIER

FAN PROTECTION GRILL

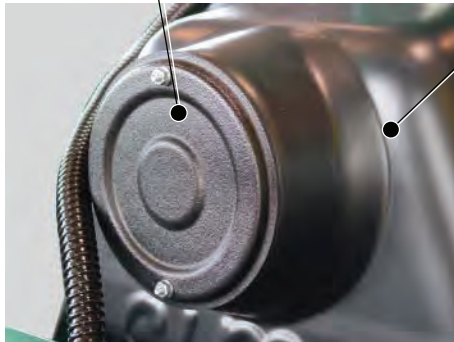

00566

00565

The access to operating areas is provided with security barriers to prevent accidental falls.

SECURITY BARRIERS



00567



THE OWNER AND/OR THE OPERATOR OF THE SPRAYER ARE NOT PERMITTED TO MODIFY THE STRUCTURE OR THE SPECIFIC OPERATION OF THE SPRAYER ITSELF. ANY REPAIRING INTERVENTION HAS TO BE CARRIED OUT EITHER AT THE DEALERS' OR AT THE C.I.M.A. S.p.A. AUTHORIZED WORKSHOPS, OTHERWISE ANY KIND OF WARRANTY IMMEDIATELY CEASES AND C.I.M.A. S.p.A. IS CLEARED OF ANY CONSEQUENT AND/OR IMPLIED RESPONSIBILITY.

2. CAUSE Obstruction of the "Y" fitting that feeds the nozzle
REMEDY: Clean.
3. CAUSE Plastic tube or olive fitting dirty or damaged.
REMEDY: Clean or replace.

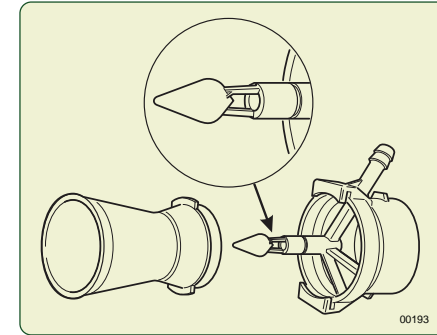

00193

4. CAUSE Faulty sealing of the hose that connects the "Y" junction to the nozzle.
REMEDY: Check the effectiveness of clamp and hose.
5. CAUSE Slight cracks of tube feeding of the nozzle.
REMEDY: Replace the tube.

H. FAULT: No spraying action delivered: totally or only on the one side of the distribution device

1. CAUSE Plate calibrated hole obstructed.
REMEDY: Clean the hole.
2. CAUSE Electrical distributor (E9) taps blocked by incrustations in the closed position.
REMEDY: Remove the cover, act on the opening/closing control rod.
Clean the distributor.
3. CAUSE Fuse of the electrical control panel (E7) when the valves of electric distributor (E9) are closed.
RIMEDIO: Replace the fuses after manual verifying the valves operation.
4. CAUSE Power cable W1 of the electrical panel interrupted or oxidized connectors of the electric distributor (E9)
REMEDY: Connect and possibly replace the defective components correctly.
5. CAUSE: Defective electrical connections.
REMEDY: Address a C.I.M.A. point of "Sale and Service".
6. CAUSE: Pump defective (only in case total delivery missing).
REMEDY: Address a C.I.M.A. point of "Sale and Service".
7. CAUSE: Broken pump belt.
REMEDY: Replace the belt (See Paragraph 14.1).

H. FAULT: No spraying action delivered only on the one nozzle

1. CAUSE Plastic tube or olive fitting dirty.
REMEDY: Clean.
2. CAUSE Faulty sealing of the hose that connects the "Y" junction to the nozzle.
REMEDY: Check the effectiveness of clamp and hose.

A. FAULT: Leakage and dripping from the pump

1. CAUSE: Non-sealing of the fittings and clamps connecting the piping to the pump.
REMEDY: Check for proper tightening of ring nuts and clamps. Check the efficiency of the sealers. Replace parts that are possibly found to be defective.
2. CAUSE: Mechanical sealing defective.
REMEDY: Address a C.I.M.A. point of "Sale and Service".

B. FAULT: Drop in pressure of the hydraulic circuit signalled by the gauge

1. CAUSE: Dirty filter.
REMEDY: Clean the cartridge
2. CAUSE: The pump filter is clogged.
REMEDY: Clean the filter
3. CAUSE: Faulty sealing of the hydraulic circuit.
REMEDY: Check the operation of the pump and the tension of its belt. Check the proper tightening of ring nuts, fittings and clamps. Check the efficiency of the sealers and the integrity of the piping. Replace the parts that are possibly found to be defective.
4. CAUSE: Gauge defective.
REMEDY: Replace the pressure gauge.
5. CAUSE: Suction or gauge connection pipe clogged.
REMEDY: Clean.

C. FAULT: Vibrations of fan unit.

1. CAUSE: Dirty fan.
REMEDY: Wash. (It is advisable to refer a C.I.M.A. point of "Sale and Service").

D. FAULT: Anomalous and continuous noisiness together with vibrations of the fan group.

1. CAUSE: Breaking of the fan shaft bearings.
REMEDY: Address a C.I.M.A. point of "Sale and Service".

E. FAULT: Intermittent operation of the whole distribution device

1. CAUSE: Lack of seal of the hydraulic circuit that goes from the tank (T1) suction pipes to the electrovalves (E9).
REMEDY: Carefully inspect all the points at which suction of air can take place, including as well those at which no liquid seepage is detected. Check the proper tightening of ring nuts, fittings and clamps. Check the efficiency of the sealers and the integrity of the piping. Reinstate the efficiency and replace parts that might have been found to be defective.

F. FAULT: Intermittent spraying only on the one side of the distribution device

1. CAUSE: Faulty sealing of the hydraulic circuit going from the manual (P8) or electrical (E7) distributor to the distribution point involved.
REMEDY: As per point E. 1.

G. FAULT: Intermittent spraying only on the one nozzle

1. CAUSE: Defect or break fitting "Y" that feeds the nozzle
REMEDY: Replace pipe fitting.

3.5 - HANDLING OF AGRO-CHEMICALS

The **operator** could become contaminated due to accidental spray, contact or inhalation of products or crop-spraying mixtures.

The **environment** could become polluted by mixture over-spills, puncturing of containers, uncontrolled storage of used and unwashed containers or spillage into waterworks.

In order to avoid these risks the preparation and filling operations must be carried out in suitably appointed and adequately equipped sites.

3.5.1 - Storage

Fixed / stationary: the site used must be well ventilated and secured by lockable doors in order to prevent even accidental access by children or unauthorised persons.

Mobile: the carrier equipment must be properly locked and kept under conditions whereby access by children or unauthorised persons can be prevented during the absence of the operator. All full or partially utilised containers must be secured against tipping, falling or breakage during transportation.

Both types of storage must:

- have a suitable container for the storing of empty packaging materials should a specific storage area not be available;
- have a clean water supply readily available for washing, by means of a specific container or through connection to the waterworks system;
- have the use of fire extinguishers, should flammable products and substances be stored.



- All packages, whether whole or partially utilised, must be stored in their original packing and with the warning instructions clearly displayed and legible.
- The storage indications must always be scrupulously adhered to, as well as their utilisation and possible disposal as suggested on the product's original packaging.

3.5.2 - Specific equipment

The site at which the preparation and filling out will take place must provide for:

- all the equipment necessary to the precise measuring of both the water quantity and the dose of product to be mixed in the tank at every filling;
- all the equipment and means useful to the preparation of the mixture and for the cleaning of the operator in case of contamination;
- all tools necessary to facilitate the direct introduction of the agro-chemicals in the tank;
- the allocation of clothing and specific equipment in order to avoid contamination by contact or inhalation during the whole operative phase of the intervention;
- the availability of proper equipment able to stop the uncontrolled spilling and flowing of the mixture;
- a retaining valve on the feed pipe when the filling of the tank takes place directly from the waterworks system.

3.5.3 - Disposal of empty containers and agro-chemicals residues

Agro-chemicals are classified as "special" waste and their disposal must take place separately from "urban" wastes.



- Empty packaging and contaminated containers to be done away with cannot be dispersed, burned or buried.
- The washing water for the cisterns and the tools utilised for the preparation of mixtures cannot be emptied on the ground, spilled into the sewage system or in waterways and rivers.

The disposal of special wastes is regulated by specific norms. In order to perform this operation it is necessary to obtain the relevant information from the Local Offices specifically appointed to rule on this subject. The non compliance with these regulations can cause considerable damage to persons and animals as well as polluting the environment.

3.5.4 - Personal means of protection

The toxicity of agro-chemicals forces persons working with them to wear adequate protective clothing and accessories in order to avoid risks of contamination by contact or inhalation.

In each of the following work stages:

- filling of tanks and adding of the agro-chemical,
- dusting and spraying,
- adjusting of the sprayer,
- emptying and cleaning of the tank,
- replacement of the agro-chemical,
- maintenance interventions,

it is necessary to wear personal protection clothing and accessories.

The following must be worn:

- Polyethylene or polyvinyl gloves.
- Full, waterproof cotton overalls, in order to guarantee transpiration, fitted with polypropylene side flaps.

In commerce, one-time 'tyvek' overalls are available which, after use (see picture), must be disposed of according to the modalities applicable to toxic waste.

- A protective half-mask in polychloroprene rubber with 1 or 2 filters. Filters for gases and organic fumes, of European A1-class vapours, are envisaged and these can be combined with anti-dust models of P1 European class, for harmful mists and powders, or P2, for harmful and toxic mists and powders.



The filters must be replaced:

- when the smell/taste of agro-chemicals can be detected, and that of active A1-class carbons;

- when difficulty in breathing is experienced for the anti-dust filters of class P1 and P2.

In any case it is necessary to make use of all personal means of protection as suggested by the manufacturers

12.8 - TABLE OF MAINTENANCE OPERATIONS

CHECK	ISEASON START TREATMENTS	BEFORE EVERY TREATMENT	END OF EVERY TREATMENT	SEASON-END	RECOMMENDED FREQUENCY
Fan belt-tensioner spring: CHECK LENGTH 9-12cm.	YES	YES	**	**	**
Pump belt-tensioner spring: CHECK LENGT 4-5cm.	YES	YES	**	**	**
Fan shaft support: CHECK OIL LEVEL	YES	YES	**	**	8 hours
Fan shaft support: CHANGE OIL	**	**	**	YES	Yearly
Tanks: CHECK FIXING CONDITION	YES	YES	**	**	**
Fan belt-tensioner support: GREASING	**	**	**	YES	200 hours
Filter: CHECK CLEANING	YES	YES	YES	YES	**
Fittings and piping: CHECK GOOD CONDITION	YES	YES	**	YES	**
Clamps and fittings: CHECK FOR INTEGRITY, PERFECT SEALING AND TIGHTENING	YES	YES	**	**	**
Hydraulic circuit and tanks: COMPLETELY DRAIN AND WASH	**	**	YES	YES	**
Sprayer: EXTERIOR WASHING	**	**	YES	YES	**
Sprayer: STORAGE	**	**	**	YES	**

8. Fasten the fan casing, with the collar (5), to the rear cover and with the collar (1) to the connection tunnel of the spray-head.
9. Install the distribution device (head).



Carefully tighten all the fastening collars' bolts.

12.6 - FAN BELT TENSIONER

Check length "L" of the spring (refer to Picture): it should be in tension between 9 and 12 cm.



If the fan control belt has to be replaced, the correct tensioning of the same one (spring length) has to be OBLIGATORILY checked after the first and after the second operation hour. If the value measured exceeds 12 cm, tighten the belt tightener screw, up to get the minimum length (9 cm).

The belt setting will take place within the first 2-3 operating hours; when that time has elapsed, verify the spring length, according with the time intervals (periodicity) indicated in the "Maintenance operations' table".

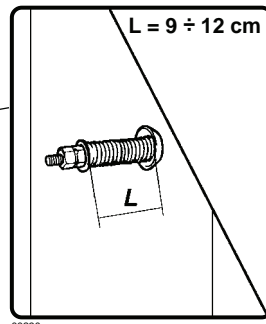

12.7 - PUMP BELT TENSIONER

Check length "L" of the spring (refer to picture): it should be in tension between 4 and 5 cm.

If the value measured exceeds 5 cm, tighten the belt tightener screw, up to get the minimum length (4 cm).

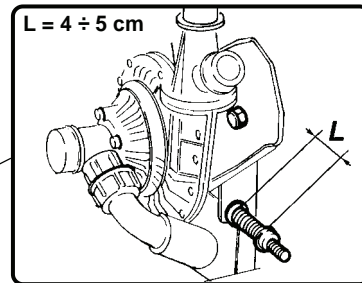
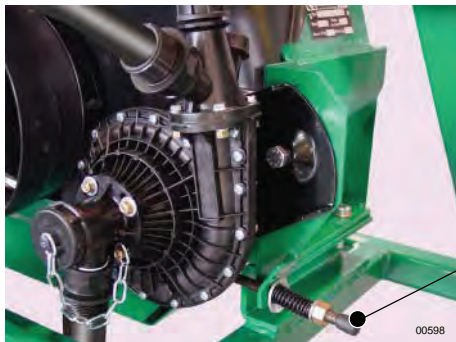

4 MACHINE'S STRUCTURAL ANALYSIS 4

The pictures indicate the position of the main components of the sprayer.

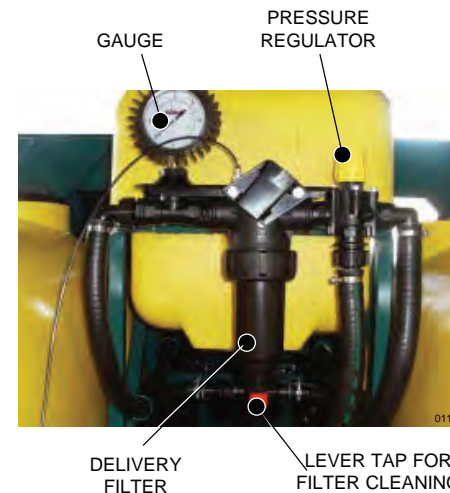
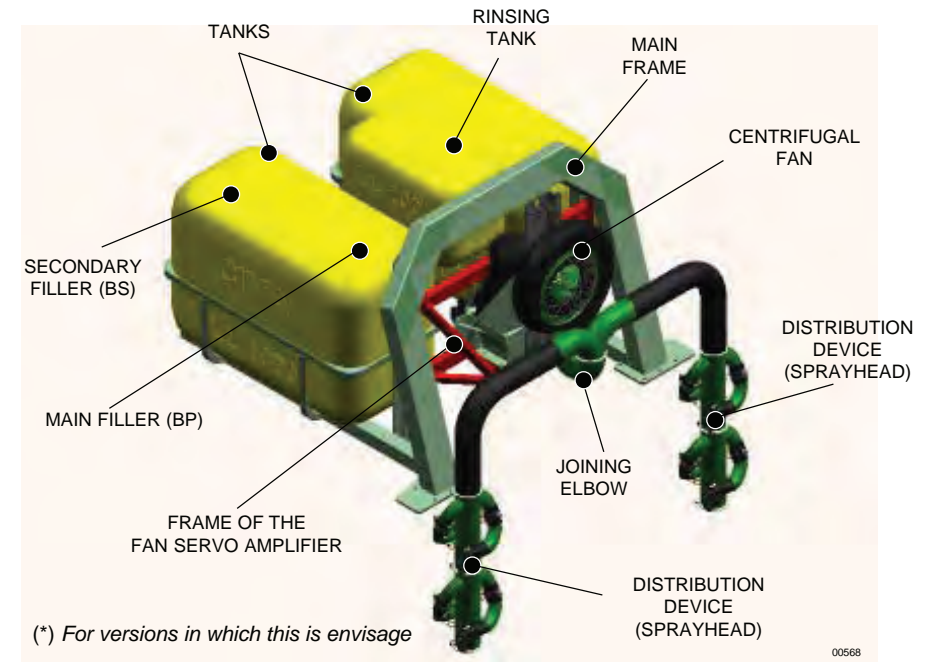

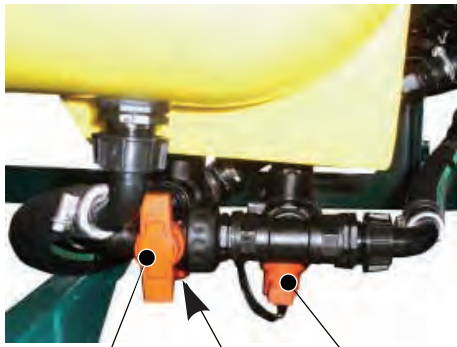
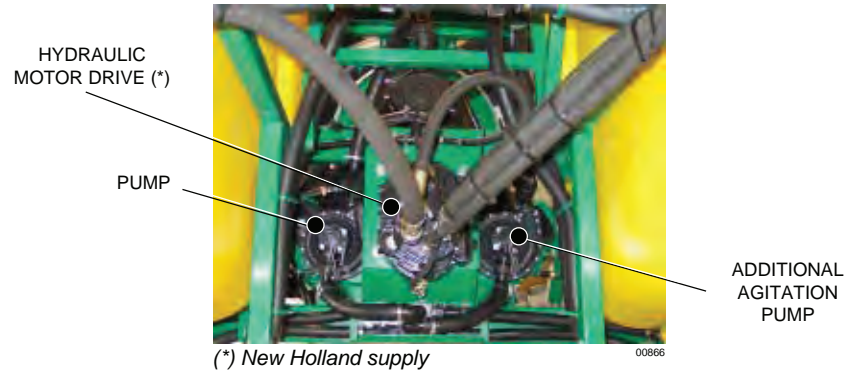

ELECTRICAL CONTROL UNIT, HYDRAULIC MOVEMENT SECTION

ELECTRICAL CONTROL UNIT, DELIVERY SECTION

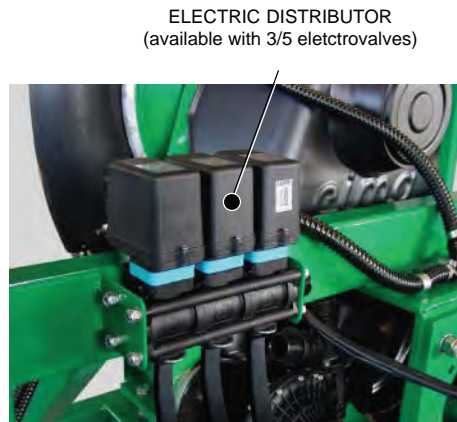

12.4 - CLEANING OF FILTER'S CARTRIDGE

1. Completely close the pressure regulator (P5) or (E5).
2. Position the switches of the control electric switchboard (E7) on "OFF" (close the solenoid valve E9)
3. Undo the thumb screw and remove the body of the filter.
4. Extract the cartridge: clean the grill and the retaining O.Ring.
5. Reassemble the cartridge and secure the lid with the thumb screw. **Pay attention to the O-Ring of the lower body during the assembly:** the incorrect sealing of the filter will jeopardise the proper operation of the sprayer and cause loss of the mixture.

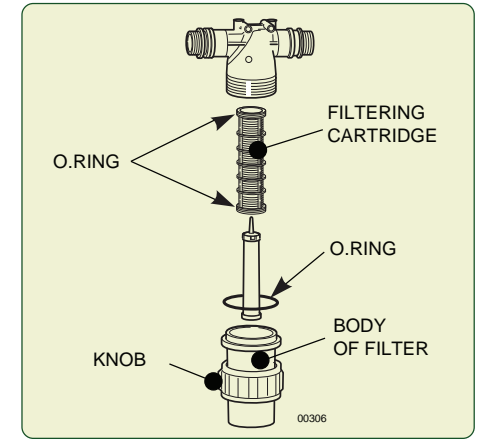

12.5 - CLEANING OF THE FAN



It is advisable for the cleaning of the fan to be carried out at a C.I.M.A service point. Dirt accumulation or incrustations can unbalance the fan, inducing vibrations that could cause breakage

1. Remove the distribution device (head).
2. Remove the fastening collar (1), fixing the fan casing outlet orifice to the connection tunnel of the spray-head.
3. Remove the two collar (5) fastening bolts, fixing the fan casing to the rear cover.
4. Remove the collar (5).
5. Extract the fan casing (2).



The impeller hasn't to be disassembled.

6. Clean the impeller, by avoiding to use high pressure water jets: they can cause infiltrations into the fan shaft support and consequently damage the bearings.
7. Mount back the casing (2), by paying a particular attention to get it perfectly coupled with the rear cover.

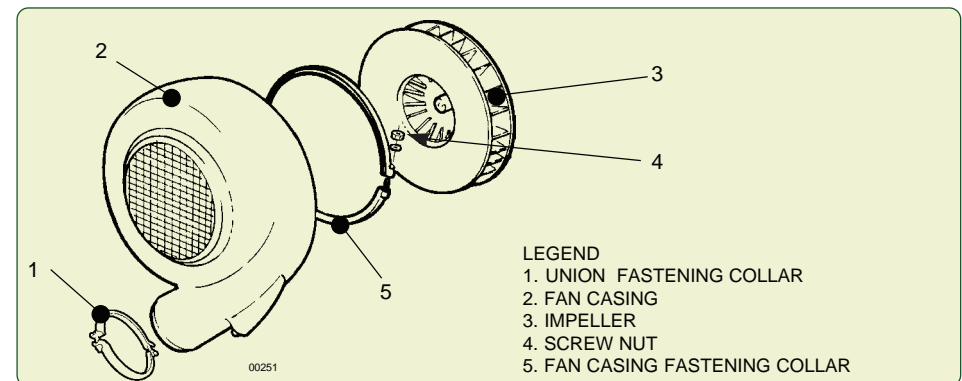

12.2 - FAN SHAFT SUPPORT OIL LEVEL CHECK

1. Unscrew and remove the oil filling plug with the dipstick.
2. Clean the dipstick and introduce it again.
3. Extract the dipstick and check the oil level, which has to be between the two minimum and maximum level notches of the dipstick itself.
Should it be necessary to top up the level, add some SAE 90 oil, up to reach the dipstick upper notch (MAX).
4. Introduce and screw the oil filling plug with the dipstick.

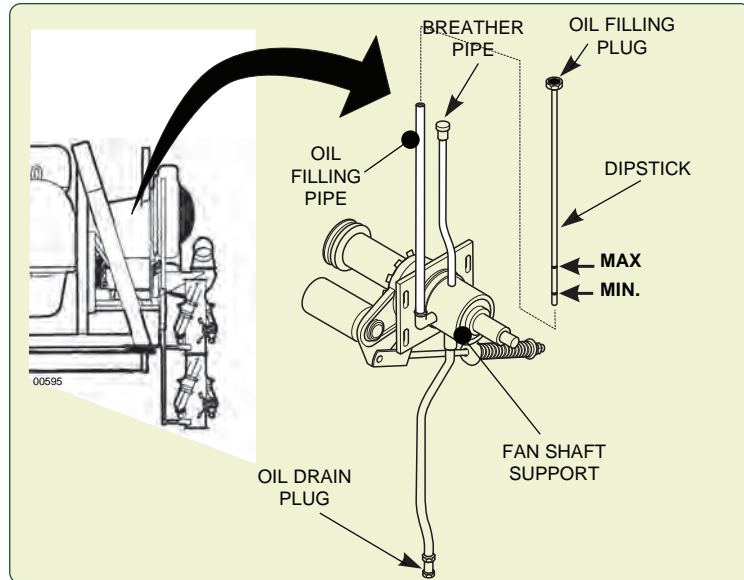

12.3 - FAN SHAFT SUPPORT OIL CHANGE



Let the fan support oil replacement intervention be carried out at a C.I.M.A. customers' service centre, or observe the regulations in force for the disposal of the used oil.

1. Unscrew and remove the oil filling plug with the dipstick.
2. Remove the oil drain plug and let the oil completely flow out from the fan shaft support.
3. Check the oil drain plug and the relevant seal for integrity, replace them, if necessary, and close again the oil drain plug.
4. Through the filling pipe, pour a SAE 90 oil proper quantity, up to reach the MAX notch on the dipstick: - about 0,24 kg.
5. Position again the plug with the dipstick and close the oil filling pipe.

4.1 - FRAME

The frame of the sprayer SPIDER has been expressly designed to match the Braud SB – VL harvesters. The frame is essentially a structure supporting the main tank and the rinsing in the front and the fan group with the sprayheads in the back. The underlying structure of the frame is equipped with drilled flanges (or guide-cones) in the back and joints to guy, one on each side, in the front, which allow the mounting of the SPIDER on the multi-purpose grape harvesters.

4.2 - FAN SERVO AMPLIFIER

The servo amplifier-fan group is mounted, by means of a specific frame, to the main frame of the sprayer. This solution allows to vary the height of the whole group and consequently the sprayheads, according to the vineyard facility.

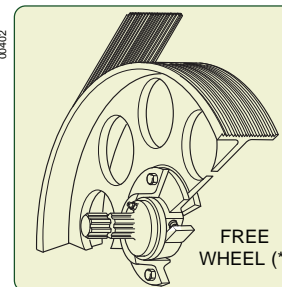

(*) For versions in which this is envisage

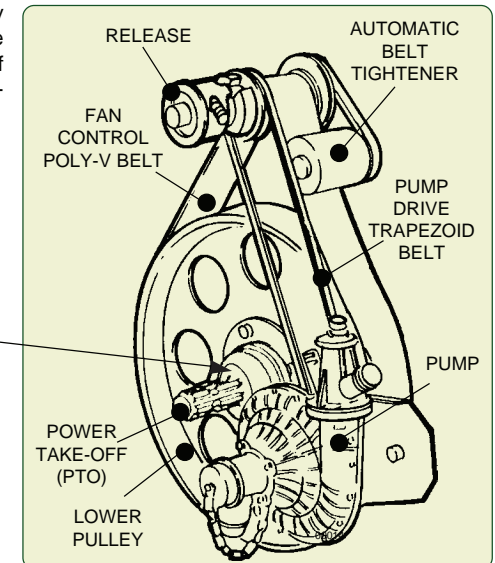

Centrifugal fan

The front-engaging clutch assembled on the fan shaft allows the operation of the centrifugal pump whitout the fan. (for versions on which it is foseen). The fan housing can rotate 360 degrees. This permits the positioning of the outlet spout at the point necessary for the assembling of the different distribution devices.

An air intake, pre-set on the outer edge of the housing, is connected to the plunger tap placed above the tank. Through this tap it is possible to carry out or exclude pneumatic agitation. The closed blades' impeller is sheet steel realized and dynamically balanced; the air intake opening on the casing is protected by a steel grating.

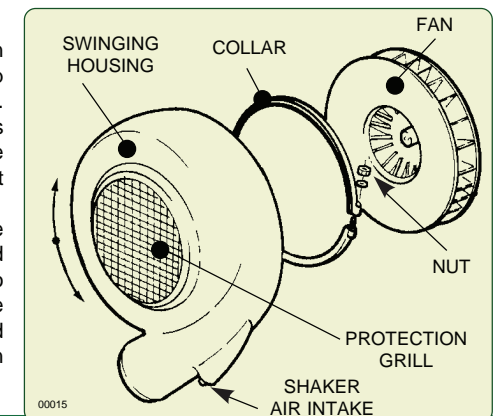

4.3 - HYDRAULIC CIRCUIT COMPONENTS

LEGEND:
P - E = elements of the circuit
T = piping

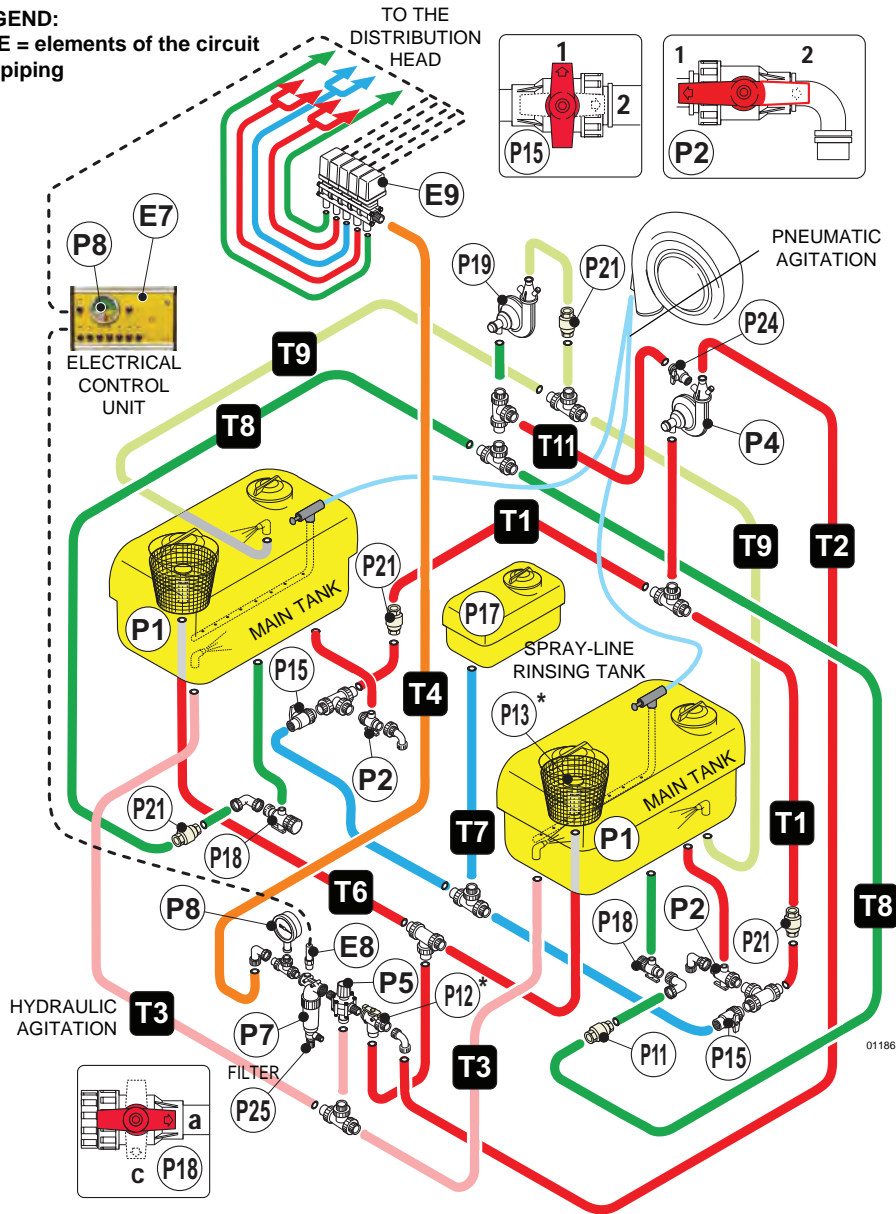

Hydraulic connections diagram

12 MAINTENANCE OPERATIONS 12

! ALL OPERATIONS MUST BE CARRIED OUT WITH THE ENGINE SWITCHED OFF AND WITH THE IGNITION KEY REMOVED FROM THE GRAPE HARVESTER CONTROL PANEL.

12.1 - LUBRICATION

Maintenance Point	Action	Consumption Material	Periodicity
Fan shaft bearing support	Oil level check	Oil SAE 90	8 hours
Fan belt-tensioner support	Greasing	Grease Type EP Classe NLGI 2	200 hours
Fan shaft bearing support	Oil change	Oil SAE 90	Yearly

👁️ Carefully clean the greasing nipples and the oil filler in order to avoid that, during lubrication, dirt might be introduced. In the case of intensive use of the machine, reduce the lubrication intervals.



11 LIFTING AND TRANSPORT 11



THE FOLLOWING ACTIONS ARE NOT ALLOWED:

- Transporting or lifting the sprayer with residual quantities of mixture in the tank for purposes differing from its destined usage.



Road transport must take place in the complete observance of road regulations in force in the Country where the machine is used. The operator is responsible for possible defaults due to the non observance of said regulations.

• Lifting and transport of the sprayer



Before carrying out any operation it is essential to verify that no mixture residues are left in the tank.

ATOMIZER HANDLING TAKES PLACE BY MEANS OF THE GRAPE HARVESTER for which THE SPRAYER HAS BEEN designed. Only for special needs raise up the atomizer by a crane or overhead travelling crane of appropriate load capacity.

1. Check that the lifting devices (bands, ropes, etc.) are adequate for the weight to be lifted (machine – distribution devices - accessories).
2. Hook the machine through the specific support point indicated by the specific decal on the frame, checking all the parts involved in the operation.
3. Lift the machine, verifying that it is properly balanced; if necessary apply guide ropes at the rear of the frame
4. Position the sprayer on the transporting vehicle in perfectly stable conditions.
5. During transport the machine must be immobilised and fastened to the carrier by way of suitable strapping.

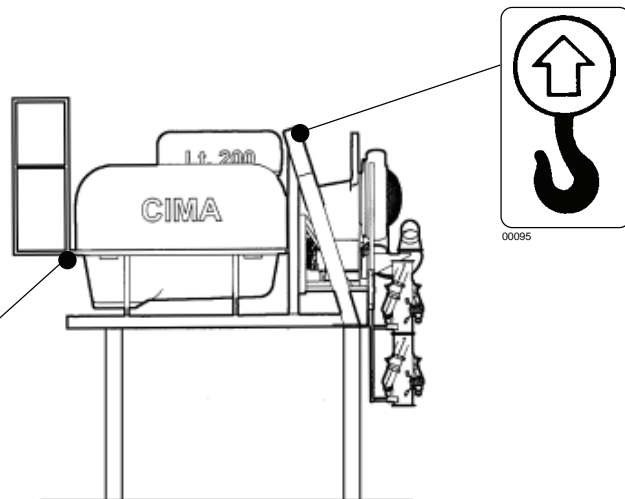

P1. MAIN TANK

Tanks utilised:
2 polyethylene tanks of 1000 litre capacity.

Each tank is made up of:

- tank main filler spout of 355 mm diameter, with collapsible lid, breather and labyrinth seal, for the filling with spraying products. Plastic cup-like filter: 302 mm external diameter, height 254 mm;
- supplementary tank filler with 250 mm diameter screw-type lid, for filling with clear water and plastic cup-like filter: external diameter 204 mm, height 240 mm;
- transparent level indicator external pipe with graduated scale;
- hydraulic agitation system connected to the regulator (P5);
- pneumatic agitation, connected to the piston tap found above the tank and connected through piping to the air intake located on the fan casing.

A = OPEN
C = CLOSED

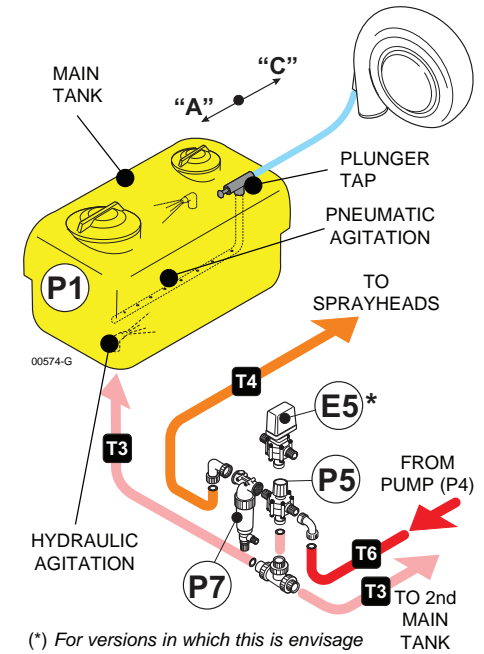

P17. SPRAY-LINE RINSING TANK

Polyethylene tanks of 100 litre capacity.

The tank is made up of:

- tank main filler with 250 mm diameter screw-type lid, for filling with clear rinsing water.
 - external graduate scale for level indication;
- The tank is connected through the taps (P15) and the pipe (T7) to the suction pipe (T1) of the pump (P4). Enables anytime the placing of clean water into the plant for the circuit washing.

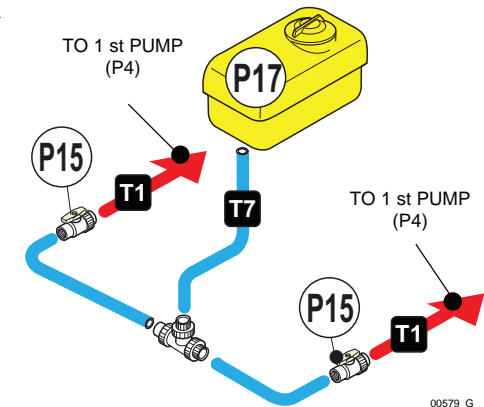

P2 - DELIVERY-DRAIN LEVER TAP WITH DRAIN RACCORD

Connected to the tank (P1) and to the suction pipe (T1) of the main pump (P4) and to the rinsing tank (P2) through the pipe (T8)..

- 1 = **DELIVERY** when the lever is oriented towards the tee raccord (external side machine).
- 2 = **DRAIN** when the lever is oriented towards the drain raccord.

 The TAP must remain normally in POSITION "1" DELIVERY. Move the lever to position "2" just to make drain (or washing with tap P15 in pos. "2" without removing the filler cap) and when COMPLETED the lever MUST BE on the WORKING POSITION ("1"-DELIVERY)

 Remove the filler cap before shifting the cock lever. When the draining has taken place, return the lever to the working position (position "1") and screw the cap back on. These operations must be carried out with the machine stopped.

 **THE PUMP MUST NEVER RUN DRY**

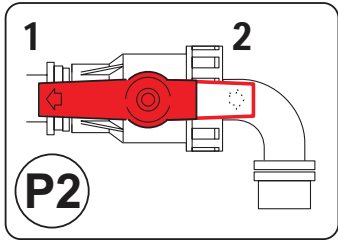

01189

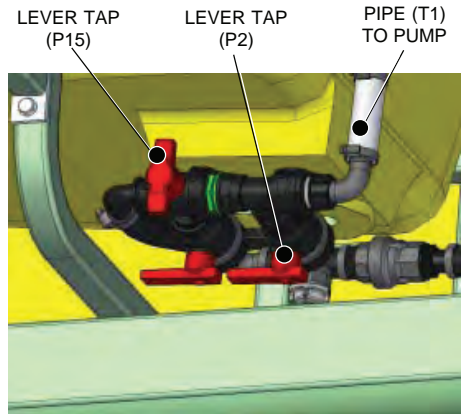

01206

P4 - CENTRIFUGAL PUMP

Fixed to the left-hand side of the machine, it is connected to the lever tap (P2) and to the pressure regulator (P5) (or to the pressure control electrovalve E5, for the diversion where foreseen).

 **THE PUMP MUST NEVER RUN DRY**

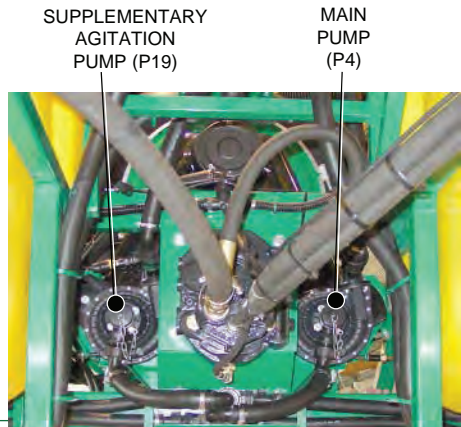

00872

10.5.2 - End of seasonal cycle

• **The operator must:**

- a. Take the utmost care in carrying out the operations envisaged at the end of the daily treatments: the cleaning of the hydraulic circuit must be done at least twice. Check that no product residues are left in any part of the circuit.
- b. Execute the necessary maintenance and lubrication operations (see paragraph 15.9), then let the atomizer operate for some minutes.

 **THE PUMP HAS NEVER RUN DRY**

- c. Completely drain the hydraulic circuit, paying a special attention to the centrifugal pumps; in order to completely drain the pump, remove the draining plug, which is mounted on the pump itself.

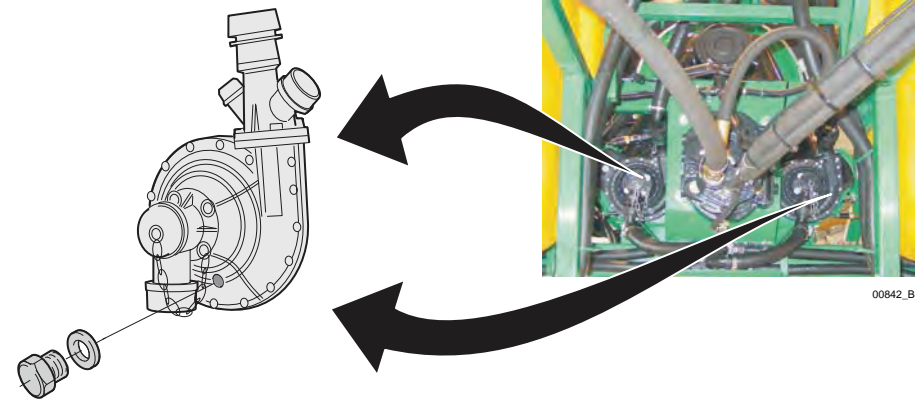

00842_B

 **Avoid using anti-freeze solutions.**

- d. Check the proper operation of all parts and of the machine structure. In case of faults being detected, request the intervention of one of our service points.
- e. Keep the machine in a well ventilated place, sheltered from rain, icing and direct sun rays.

 **The use of detergent products for the cleaning operations is allowed only in the observance of the regulations in force. For these, the operator must gather the relevant information from the specifically appointed bodies ruling on this subject.**

- c. Close the electrovalves (E9) by taking the switches of the control electric switchboard (E7) on **OFF**.
- d. Decrease progressively the pressure by turning the knob of the regulator (P5) counterclockwise (or keeping the joystick on the electric control unit in the direction of "-"), until reaching the pressure of ~1 bar on the pressure gauge.
In this way, the clean water contained in the spray-line rinsing tank is sucked from the pump (P4) and sent, through the by-pass of regulator and hose (T3), to the main tanks. The second pump (P19) picks up water from reservoirs and feeds the hydraulic circuit of agitation and in this way to wash the same.
- e. Increase progressively the pressure by turning the knob of the regulator (P5) clockwise (or keeping the joystick on the electric control unit in the direction of "+"), until reaching the operating pressure on the pressure gauge.
- f. Stop the hydraulic motor of grape harvester.
- g. Bring before the lever tap (P15) and later the lever tap (P2) in position **1-WORKING**.



It is recommended to wash the second pump when, between a treatment and the other, the machine remains unused for a long enough, but not such as to fall within the daily term of use.

10.5 - END OF TREATMENT - STORAGE

10.5.1 - Daily

- **The operator must:**
 - a. Wash the machine's exterior before cleaning out the hydraulic circuit. The operative sequence will permit the elimination of possible water residues from the fan casing and piping conveying the air flow to the heads.
-  **The washing of the sprayer's exterior must be carried out in an area in which foul waters are collected in a disposal pit. DO NOT UTILISE HIGH-PRESSURE HYDRO-CLEANERS.**
- b. Carry out the complete hydraulic circuit cleaning process, by washing the tank inside with a clean water jet; then, he has to operate the sprayer, by spraying the tank contents on the ground, in conformity with the antipollution directives in force in the country where the machine is employed: if necessary, repeat the whole procedure.
 - c. Check the efficiency of the distribution device (head) and the cleaning of the pulverising points (diffusers), possibly replacing them if found to be damaged.
 - d. Clean out the filter cartridge.
 - e. Keep the machine in a ventilated place, sheltered from rain or sun: sunrays are the worst enemies of plastic and rubber parts.

P5. MANUAL PRESSURE REGULATOR

It is mounted on the tank and connected through pipe (T2) to the filter (P7). It adjusts the operating pressure by checking the return flow into the tank.

- **By closing it: it REDUCES the return flow** to the tank and therefore, the agitation of the mixture, and increases the operating pressure and the capacity flow to the head (rotate the handle clockwise).
- **By opening it: it INCREASES the return flow** to the tank and therefore, the agitation of the mixture, while reducing the operating pressure and capacity flow to the head (rotate the handle anti-clockwise).



01186

E5. PRESSURE CONTROL ELECTRO-VALVE

(for the version where foreseen)

It is connected to the delivery filter (P7) and, through pipe (T3), to the tanks (P1). It regulates the operating pressure, by controlling the return flow to the tanks. The regulator is controlled through the joystick on the electric control unit (E7).

- **Moving the joystick downwards (-)** on the electrical control gearbox, the **electrovalve opens: in the tank both the backflow and the agitation of the mixture increase** while the values of the working pressure and the delivery to the sprayhead decrease.
- **Moving the joystick upwards (+)** on the electrical control gearbox, the **electrovalve closes: in the tank both the backflow and the agitation decrease** while the values of the working pressure and the delivery to the sprayhead increase.



When they treat with heavy powder, which can form mixture deposit on the tank bottom, it is necessary to operate with a pressure of 1-1.5 atm to get greater hydraulic agitation of the mixture and avoid it.

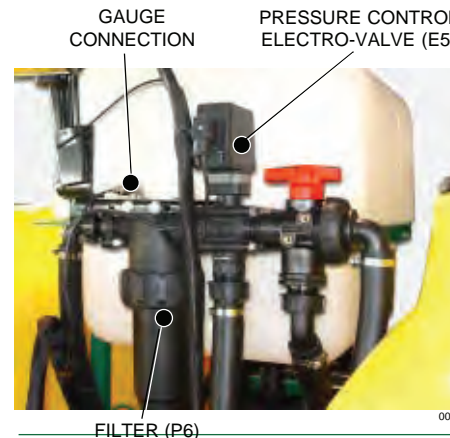

00864

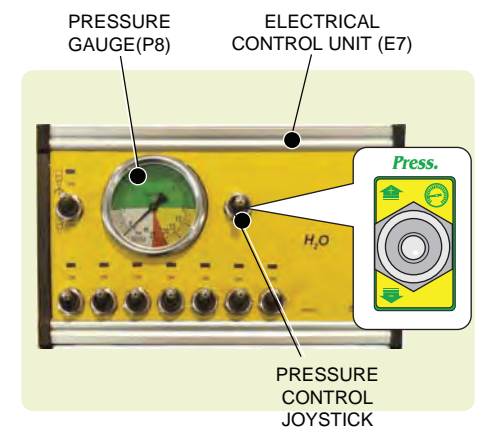

P7. FILTER

The filter has a filtering capacity of 250 l/min., with a 50 mesh cartridge. The dirty cartridge causes the operating pressure chute.

This inconvenient is signalled by the pressure gauge. Mounted on the feeding pipe, it only filters the delivery flow to the heads, by sensibly reducing the possibility for the cartridge to get obstructed.

P25. SELF-CLEANING FILTER TAP

(for the version where foreseen)

It is placed on the bottom of the filter (P7).



Before proceeding to the discharge of residues of the product that clog the filter, the tap MUST BE CONNECTED to a pipe which discharges into a suitable collecting vessel. The mixture from the pump (P4) passes through the filter (P7) removing product residues, that can cause clogging of the filter.

a - Open, filter CLEANING

The mixture from the pump (P4) passes through the filter (P7) removing product residues that can cause clogging of the filter.

c - Closed, TREATMENT

P8. GAUGE

Glycerine-dipped, with dial from 0 to 6 Kg/cm² (atmosphere) – adjustments scale of 1/10 of atmosphere, 100 mm diameter; it is connected to filter (P7).



Set the working pressure keeping the E9 distributors opened.

E8. TRANSDUCER OF THE DELIVERY PRESSURE

(for the version where foreseen)

Where available, the pressure transducer is connected to the electrical control unit (E7), where the pressure gauge is replicated to allow the reading directly from driver's seat of grape harvester.

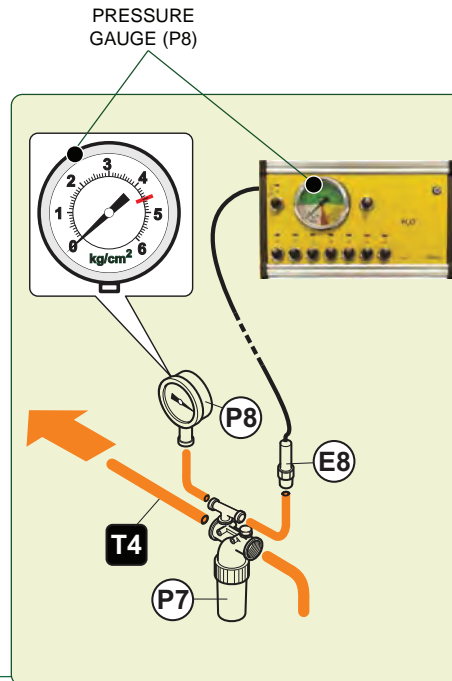
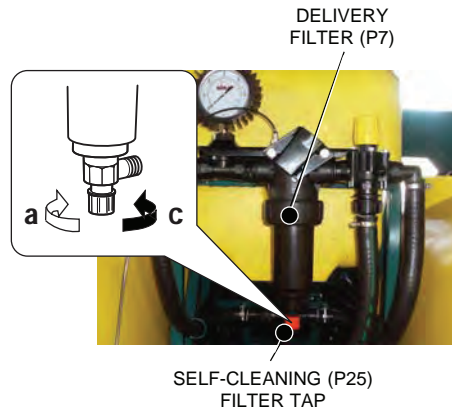

- d. Increase progressively the pressure by turning the knob of the regulator (P5) clockwise (or keeping the joystick on the electric control unit in the direction of "+"), until reaching the maximum pressure on the pressure gauge; in this way, the clean water contained in the spray-line rinsing tank is sucked by the pump (P4) and entered in the hydraulic circuit by performing washing circuit.



THE PUMP MUST NEVER RUN DRY.

- e. Open the electrovalves (E9) by taking the switches of the control electric switchboard (E10) on **ON**; make the atomizer work spraying on the piece of ground not treated yet.

That easy procedure allows to eliminate every fuel mixture residual from all the hydraulic circuit components, so assuring in first place the accurate cleaning and the consequent efficiency of the calibrated holes of the rotary disc regulators.

- f. Decrease progressively the pressure by turning the knob of the regulator (P5) counterclockwise (or keeping the joystick on the electric control unit in the direction of "-"), until reaching the operating pressure on the pressure gauge.



If after spray-line rinse (pump-head) you plan to perform the washing of 2nd pump (further agitation) keep this condition for at least 30 sec. to allow entry in the main tank of the necessary quantity of clean water.

- g. Stop the hydraulic motor of grape harvester.
- h. Open the lever tap (P24) for 2nd delivery exclusion of main pump - position "a".
- i. Bring before the lever tap (P15) and later the lever tap (P2) in position 1-WORKING.

10.4.2 - Washing of 2nd pump (additional hydraulic agitation)

Washing of the 2nd pump (additional hydraulic agitation) can be executed only with the main tanks almost empty.



Wash the second pump ONLY after washing the hydraulic circuit (see Paragraph 14.4.1) and having maintained the sprayer functioning at the operating pressure (1.5 bar) for at least 30 sec. in order to allow entry main tanks of the quantity of clean water needed to wash the second pump.



THE PUMP MUST NEVER RUN DRY.

- a. Bring before the lever tap (P2) and later the lever tap (P15) in position 2-WASHING.
- b. Start the hydraulic motor and bring it up to operating r.p.m. rate (540 RPM - see paragraph 4.4).

10.3 -THE TREATMENT



IT IS ADVISABLE TO BEGIN TREATMENT AT THE HEADLANDS

- **The operator must:**
 - a. **Shake the mixture** in the tank before starting the treatment, re-circulating it completely for as long as it takes to make it homogeneous.
 - b. Check the **orientation of the distributors (hands and/or cannons) of the distribution device (sprayhead) in relation to the dimensions, the shape and the thickness of the vegetation to be treated.**
 - c. Continue to shake the mixture until the treatment is resumed should the intervention momentarily be interrupted. If the utilisation is to be deferred, check that the filter cartridge is clean before resuming and **agitate the mixture** that has remained in the tank.
 - d. Ensure that the hand wash supplementary tank is filled with clean water after each filling operation.
 - e. Make use of individual protections identical to those envisaged for the preparation of mixtures if the tractor is not equipped with a pressurised cabin with aeration filters.
 - f. Wash immediately all the elements that might have become contaminated during the treatment, promptly remove the polluted garments and **interrupt the work if these cannot be immediately replaced.**
 - g. Keep to the preliminary operations already indicated (10.1.c), in case of wind conditions prevailing.
 - h. During the breaks, stop the engine, remove the key from the grape harvester's control panel.
 - i. Pay particular attention to the treatment when close to boundaries and in proximity of dwellings, waterways, roads or public-usage paths.

10.4 - PROCEDURE TO WASH THE HYDRAULIC CIRCUIT

10.4.1 - Delivery hydraulic circuit (head-pump)



Every time it is necessary to suspend the treatment, it is possible to carry out the hydraulic circuit washing process, independently on the loading conditions, i.e., also when the tank is still containing some product mixture, so avoiding any possible clogging and assuring the perfect efficiency of the machine when the treatment is carried on again.

- a. Bring before the lever tap (P2) and later the lever tap (P15) in position **2-WASHING**.
- b. Close the lever tap (P24) for 2nd delivery exclusion of main pump - position "c".
- c. Start the hydraulic motor and bring it up to operating r.p.m. rate (540 RPM - see paragraph 4.4).

E7. CONTROL UNIT

The upper section of the control unit (E7) (supply section) is connected to the distributor with 3/5 motorised solenoid valves (E8) and to the main socket of the grape harvester. A warning lamp (green) light on to indicate the presence of power supply.

The lever switches, controlling the solenoid valves (E9), have to be set to "ON" for opening and to "OFF" for closing.

The main switch ON/OFF controls the flow of the mixture to the distribution head; the operating pressure is adjusted by a pressure regulator knob (P8) (or via the joystick for the control pressure solenoid valve - E8 – where foreseen) and it is indicated by the gauge (P8).

Each switch has a light indicator (red) for the position ON (valve open).

The lower section (hydraulic movements) is connected to the hydraulic control unit, where the hydraulic pipes for the sprayhead movement are linked.

Using the two central JOYSTICKS, they can raise and lower the sprayhead right and/or left sections: pushing them up the sprayhead rises, pushing them down the sprayhead goes down.

In the same way, they can fold the sprayhead RH/ LH sides sections by the two lateral JOYSTICKS. The position of the joysticks on the control unit reflect the position of the sprayhead sections.

The control unit is equipped with a bayonet support to be inserted in the bracket provided.

This must be mounted on the grape harvester, within the driver's reach. When the machine isn't hitched to the grape harvester, it must be placed in the position foreseen near the group filter-regulator-manometer.

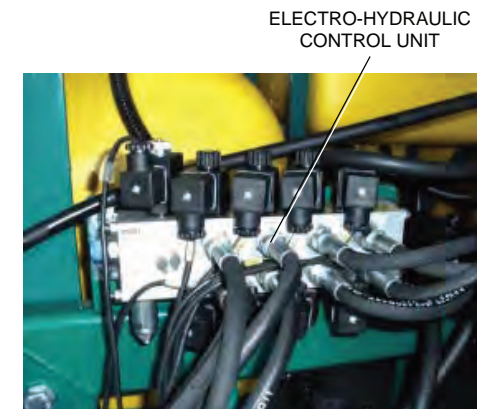
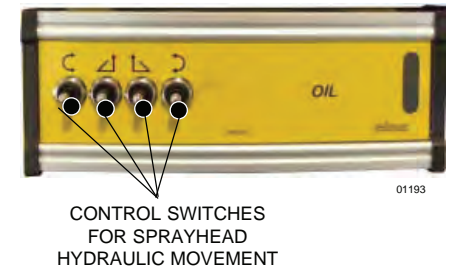
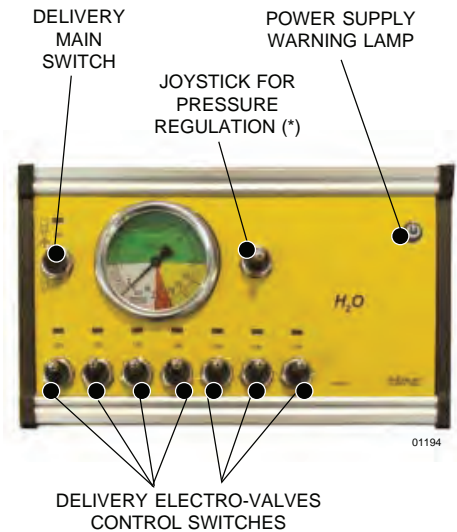

E9. ELECTRICAL DISTRIBUTOR WITH 3/5 SOLENOID VALVES

It is connected with the feeding pipe (T4), the distribution pipes (T5) and the electrical unit (E7), which is fastened on the grape harvester. The solenoid valves open and close themselves, according with the action carried out on the electrical control unit switches.

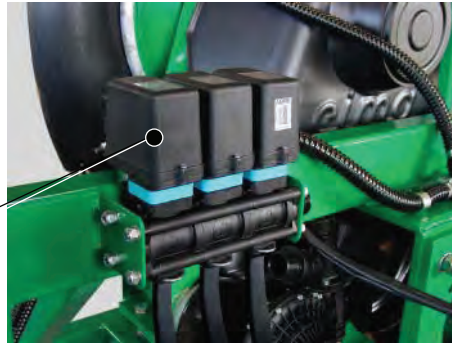

ELECTRICAL DISTRIBUTOR (E9)
(available with 3/5 solenoid valves)

00569

P10. CALIBRATION DISC (Patented Nr. 23238)

It selects the flow rates necessary to the treatment and is mounted on the distribution devices. It is made up of 2 flanges, held in position by two butterfly nuts, locking a disc with calibrated holes numbered from 1 to 15. A groove on the edge of the disc allows the exact positioning of the hole to be utilised. Its number must appear in the flange's semi-circular seat. The rotation of the disc is obtained by loosening the butterfly nuts by a few turns. After the operation is done, screw back carefully.

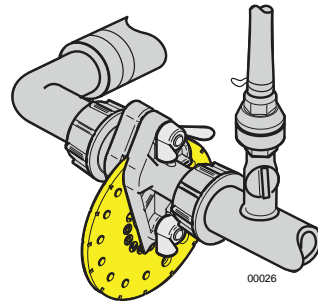

00026



Any faulty sealing condition of the hydraulic circuit causes an intermittent issuing of the sprayed material. It is necessary to carefully check the efficiency of the sealers and clamps, the tightening of the ring nuts and fittings and the good working condition of the piping.

P18. LEVER TAP (additional agitation)

Positioned on the pipe (T8), between the centrifugal pump (P19) and the main tank (P1).



When the sprayer is running the tap MUST REMAIN NORMALLY OPEN: the lever is parallel to body of the tap oriented towards to flexible pipe (position "a"). Positioning the lever perpendicular to the body of the tap (position "c"), the secondary pump suction is excluded, and therefore the additional agitation too.



THE PUMP MUST NEVER RUN DRY

• The operator must:

- a. Wear adequate protective clothing and accessories such as overalls, waterproof suits, gloves, glasses and masks to shield him from contamination by inhalation or contact with the products handled.



- Anti-dust masks don't offer any protection against toxic vapours.
- Avoid wearing loose clothes that might entangle with moving parts.

- b. With the parameters defined during the preliminary operations, carry out the adjustments of the sprayer.
- c. Prepare the mixtures in a well ventilated area. When in the open, the presence of wind increases the danger of contamination.
- d. Precisely weigh the previously calculated doses of products to be mixed at every filling operation.
- e. Avoid handling products close to open flames, embers, incandescent bodies or in the presence of flammable substances.
- f. In order to obtain the correct volume dosage of agro-chemicals and fertiliser mixtures, the fertiliser must be first diluted.
- g. Wash and rinse the just emptied product containers with clean water – collect the washing water and pour it in the tank before carrying out the filling – place the empty packaging in the specific container or in the collection area.
- h. Wash the equipment and tools utilised in the preparation and place them in the chemical products storage area.
- i. **Always** leave the area assigned to the loading and preparation of the mixtures in such condition as to avoid **any** possibility of contamination to persons or animals or of pollution to the environment.
- l. After complete filling of the machine, fill the hand wash tank using clean water.
- m. If necessary, mark the field or the area of machine passes in order to provide a guide for the treatment and avoid missing or double-treating coverage areas.



• AT THE END OF THE OPERATIONS NECESSARY FOR CARRYING OUT THE INTERVENTION, THE LOCATION-STORAGE AREAS MUST BE LEFT IN THE CONDITION REQUIRED FOR THE CARRYING OUT OF THEIR PREVENTION AND PROTECTION FUNCTIONS.

• BEFORE STARTING THE GRAPE HARVESTER, KEEP AWAY PERSONS OR ANIMALS AND NEVER LEAVE IT UNATTENDED DURING THE PREPARATION OPERATION.

10.1 - PRELIMINARY OPERATIONS TO TREATMENT

• The operator must:

- a. Ascertain that the condition of the crops, the progress of the disease or the need for its prevention actually justify the treatment to be applied.
- b. Be aware of the meteorological conditions forecast for all the time necessary for carrying out the treatment.
- c. If possible, avoid carrying out the spraying in strong wind conditions or when one detects that the sprayed mixture disperses away from the target crop (drifting). It is advisable to suspend the treatment when the wind speed exceeds 3 m/s (10 km/hour). Should it be imperative to operate anyway, the following suggestions are made:
 - reduce the distance of the target from the spraying points, even if detrimental to the quality of the spraying
 - increase the dimension of the droplets, suitably adjusting the machine.
- d. Check that multiple-product mixtures be physically, chemically and biologically compatible amongst themselves; if need be, obtain the necessary information from the products' sales representative.
- e. Carefully calculate the exact quantity of the product necessary for the treatment and establish the volume of water to be used for the intervention.
- f. Check that the product is available in a quantity sufficient to complete the intervention.
- g. Read the product's utilisation instructions carefully, in order to ascertain the usage conditions, the correct dosage and the expiration dates.
- h. Make sure of the parameters necessary to the adjustments of the machine and determine the exact dose of product to be applied to every loading. **Follow the instructions of the publication titled "The low volume - Instructions for sprayers adjustment" as well as those contained in the use and maintenance book-let of the distribution device.**

10.2 - PREPARATORY OPERATIONS TO TREATMENT



THE FILLING MUST BE CARRIED OUT WITH THE MACHINE ON A FLAT SURFACE. BEFORE THE OPERATION, IN THE ALLOCATED AREA, THE DOSES OR MIXTURES TO BE POURED IN THE TANK MUST BE MADE READY.

Before starting the filling cycle, check:

- THE EFFICIENCY OF THE DISTRIBUTION DEVICE (SPRAYHEAD);
- THE CLEANING OF THE FILTER CARTRIDGE (P7);
- THE LEVEL OF THE OIL OF THE FAN SHAFT SUPPORT.

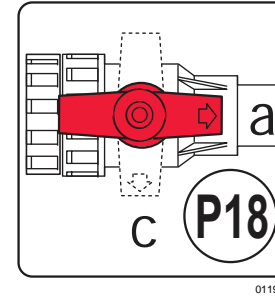

01196

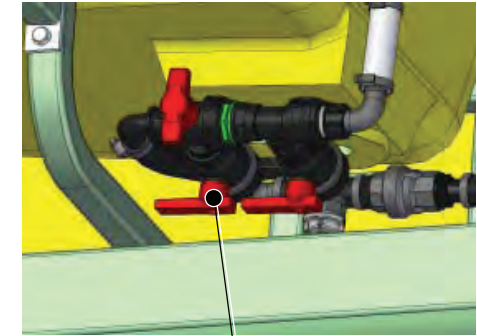

01206

LEVER TAP(P18)

P21. NON-RETURN VALVE

The non-return valves preventing backflow of fluid pumps to tanks, in case of a shutdown of the sprayer.

P19. ADDITIONAL AGITATION PUMP

Fastened on the machine right side, it is connected to the tank (P1) through the pipes (T8 - suction) and (T9 - delivery). The operation of the 2nd pump allows the additional hydraulic agitation of the mixture contained into the two main tanks.

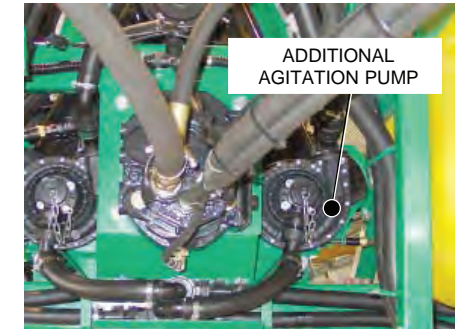

ADDITIONAL AGITATION PUMP

00872



THE PUMP MUST NEVER RUN DRY.

P24. TAP FOR 2nd DELIVERY EXCLUSION OF MAIN PUMP

It is positioned on the pipe (T11) of the 2nd delivery of main pump (P4) to additional agitation pump (P19). The tap must remain ALWAYS OPEN position ("a"). The "c" position (closed) allows the spray-line rinsing.

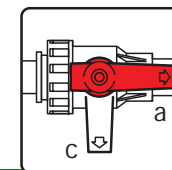

00105



01197

P12. POWDER MIXER LEVER TAP (For versions in which his envisaged)

Fixed to the electro-regulator (P5) and connected by the pipe (T6), to the mixer powders (P13) of the tank main filler.

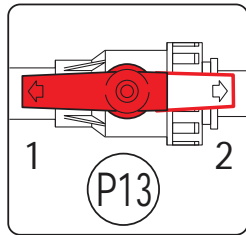

When sprayer is running, the tap MUST remain in the position "1"; the tap lever is parallel to the body of the tap itself, and towards the filter. Moving the lever to the outwards position (position "2"), you get the powders mix. IT IS NOT POSSIBLE TO SUPPLY THE TREATMENT.

P13. POWDER MIXER

(for the version where foreseen)

It makes the mixing of the powdery products during the filling of the tank. It is mounted on the basket filter of the main filler (BP) and it is connected to the pump (P4) through the lever tap (P12).

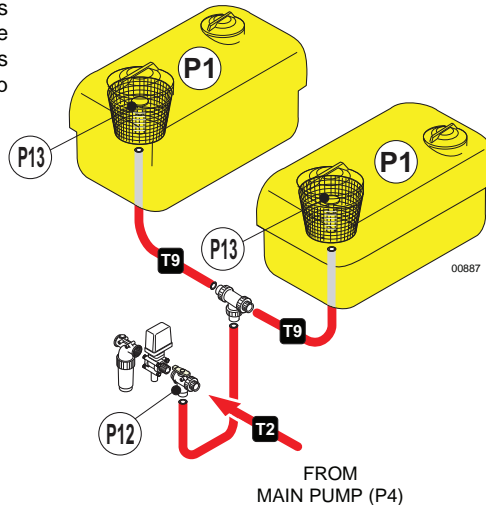

8 AGITATION 8

The **hydraulic** and the **pneumatic** circuits mounted inside the tank, allow to realize a **double agitation system**: with the pump water and with the fan air, **at the same time**. The pneumatic circuit can be excluded, when the products used have a quite strong foaming effect, by closing the pneumatic agitator cock. When that cock is opened again, check that some air outlet holes aren't obstructed.

It is advised however to also use always the pneumatic agitator, adding to the mixture, if necessary, a antifoam product.

This operation is of main importance, in order to get a uniform distribution of the active principle on the whole vegetative surface to be treated. Should the activity need to be interrupted during a treatment with the sprayer, **keep the agitator activated until the treatment is resumed.**

Before starting the treatment, or return to work after a break, it is essential to agitate the mixture in the tank, re-circulating it completely for as long as it takes to make it homogeneous.

The agitation must be carried out with the manual pressure regulator (P5) (or electric E5) fully open for the first use of the machine or in a position already selected for the current or previous treatment. Also the taps (P18) and the piston cocks of the pneumatic agitation must be open.

DO NOT CLOSE THE TAPS (P2) TO PREVENT THAT THE PUMP RUN DRY.

In case of interruption of the work during the use of the sprayer keep shaking until the resumption of treatment. If it is deferred, before resuming again, **shake the mixture** remains in tanks. **THE AGITATION OF THE MIXTURE SHALL BE CARRIED OUT WITH THE HYDRAULIC MOTOR AT THE WORKING REGIME.**

9 TANKS AND HYDRAULIC CIRCUIT DRAINING 9

- Stop the grape harvester and remove the key from the control panel.**
- Wear suitable protective clothing and accessories in order to avoid contamination by contact or inhalation of the mixture.**
- Carry out the discharging in a suitable and properly geared area for the collection of the washing liquid.**

This operation has to be carried out with the lever tap (P2):

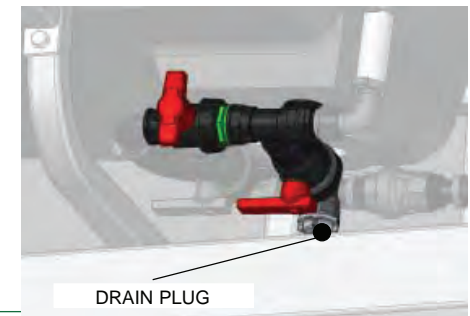

1. Unscrew drain plug only when the lever tap is in position "1". (Agitation-draining closed).
2. Turn the lever to position "2". (draining open).
3. When the draining is completed, position again the lever tap (P2) to "1" (agitation), and screw again the chain plug.



4. Reposition the mobile protection cover and fasten the locking nuts properly.
5. Start the grape harvester and carry out the filling operation.

7.1.b Fan engagement to perform the treatment

EXECUTION:

1. Disengage the power take off (PTO)
2.   **Stop the grape harvester, remove the key from the control panel and check that the fan is stopped.**
3. Unscrew the nuts that fix the protection mobile cover and remove it to enter the release.
4. Fully press the spring push button, push the front body forward, if necessary, turning it to the right or left, until the frontal teeth of the joint engage the corresponding teeth of the pulley; at the same time, the spring push button must return to the outward position. This way, the body is again integrated with the pulley, thus transmitting the movement to the fan.
5. Reposition the mobile protection cover and suitably tighten the securing nuts.
6. Start the grape harvester.

7.2 - FILLING THROUGH POURING FROM THE TOP



For this type of filling, use the supplementary filler (BS) located in the upper side of the tank, towards the rear of the sprayer.

THE INLET OF THE FILLER PIPING MUST NEVER COME INTO CONTACT WITH THE ANTI-PARASITIC MIXTURE: IT MUST ALWAYS BE KEPT AT A SAFE HEIGHT ABOVE THE TANK FILLER AND MUST BE EQUIPPED WITH A NON-RETURN VALVE.



THE PUMP MUST NEVER RUN DRY

EXECUTION:

1. Close the cocks of the distributor (E9): position to "OFF" the quick-break switches on the control panel (E7).
2. Verify that the cock:
 - P2 and P15: are in WORKING position (levers on "1");
 - P18: is in AGITATION position (lever on "a");
 - P24: is open (lever on "a");
 - P12 (for the version where foreseen): is in position "2" (MIXING);
 - P5 (or E5), pressure regulator: is fully open for the first use of the machine or in a position already selected for the current or previous treatment.
3. Pour some water into the tanks, for about 50 litres, by acting from the secondary filler (BS).
4. Pour the mixture of water and plant protection product previously prepared (or the liquid product) (and the possible washing water for the medicine packs and for the instruments used for preparing the mixture) into the main filler (BP).
5. Close the main filler (BP) of the tanks.
6. Start the hydraulic motor and bring it up to operating r.p.m. rate.
7. Complete the filling with water through the secondary filler (BS) and close the cover .
8. Close the cock (P12) y positioning the lever on "1" (WORKING).
10. Move to the place to be treated, by keeping the mixture agitation with the hydraulic motor at operative rate along the whole way.
11. CARRY OUT THE TREATMENT.

P15. SPRAY-LINE RINSING LEVER TAP

It connects the unit-washing tank (P17) to the main pump (P4) suction by means of the pipes (T7) and (T1).

The tap (P15) lever can be placed in the following positions:

1 - Treatment (Work)

The fluid gets out from the tank (P1) and is sucked by the pump (P4); that is the **NORMAL** operation position, which is used in order to carry out the treatment and/or to keep the mixture. **The pipe connection to the unit-washing tank is closed.**

2 - Washing process

The fluid gets out from the unit-washing tank (P17) and is sucked by the pump (P4); that is the position which is used, in order to carry out the hydraulic circuit **WASHING**.



The unit-washing circuit allows to wash the hydraulic circuit (with the exclusion of the tank), in every moment and independently on the tank load conditions, i.e., also with the mixture present inside the tank.

Bring the lever tap (P2) in position "1" - by excluding the suction from the main tank. Close the lever tap (P24) to avoid the clean water returns in the main tank, with a consequent dilution of the mixture and **CLOSE COMPLETELY** the manual regulator (P5), or the electrical one (E5), during the cleaning process.

When the tap (P15) is placed to position "1 - open", the clean water for the unit washing is taken from the unit-washing tank (P17).

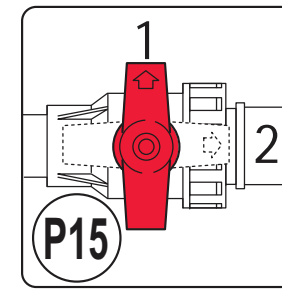

01187

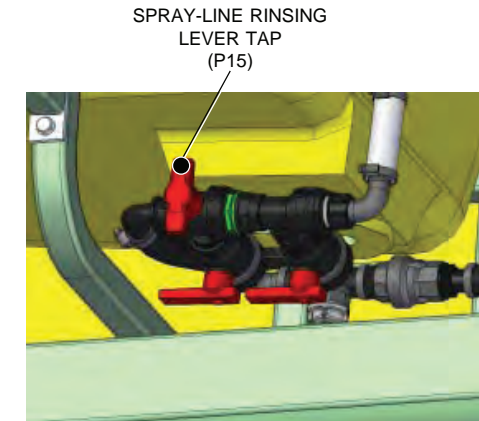

01206

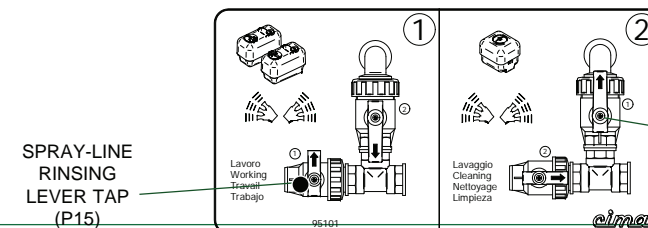

SPRAY-LINE RINSING LEVER TAP (P15)

96101

DELIVERY/ DRAINING LEVER TAP (P2)

4.4 - GRAPE HARVESTER OPERATIVE CONTROLS

When the sprayer SPIDER is mounted on grape harvester, some controls are available in the cab; the controls normally used for the operation during the crop, are used for the operation of the atomizer too.



The following information are to be considered **PURELY INDICATIVE** in relation to the layout of the grape harvester, which can vary at the discretion of the Constructor of the same. For connection and use of the controls refer to the "Operation and maintenance instruction" manual of the grape harvester (installation accessories).

Hydraulic power supply

1. Extractors start/stop switch (start pump of power hydraulic motor);
2. Main switch;
3. Extractor speed adjustment switch (PTO speed of power hydraulic motor.
4. PTO tachometer;



To start the hydraulic motor bring the grape harvester engine to max RPM and switch-on the switches (2) and (1), then progressively operate by switch (3) until the regime of 540 RPM is read on the speedometer (4) (see. "Operation and maintenance instruction" manual - grape harvester). The operation of the feeding pump of hydraulic motor is indicated by the warning lamps on relevant switches.

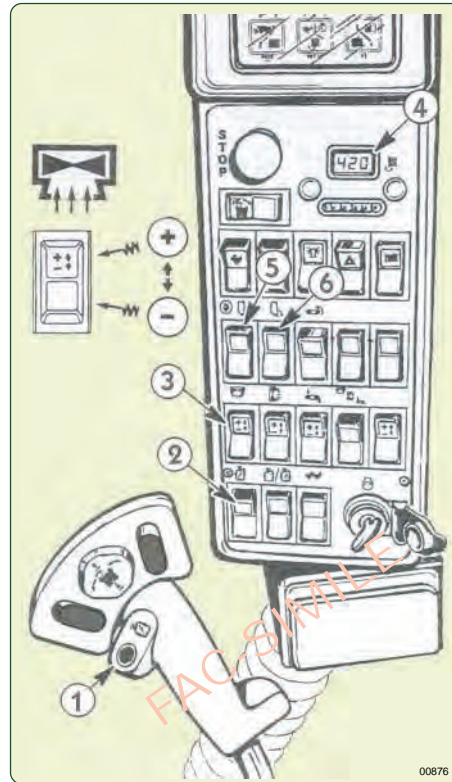

Hydraulic power distribution device (sprayhead)

5. witch for left tipping buckets control (electrohydraulic power unit for sprayhead movement).

7 FILLING 7



THE SPRAYER HYDRAULIC CIRCUIT CONSISTS OF TWO SYMMETRICAL PARTS, RIGHT AND LEFT, CONNECTED BY MEANS OF TEE RACCORDS. BOTH SIDES OF THE CIRCUIT ARE FITTED WITH OPERATING TAPS. IN THE FOLLOWING DESCRIPTIONS OF THE USE OF THE TAPS ARE INDICATED IN THE SINGULAR (example: Open tap P2) BUT MUST BE UNDERSTOOD AS REFERRING TO BOTH FAUCETS. OPERATE ONLY ON ONE SIDE OF THE HYDRAULIC PLANT CAUSES THE EMPTYING OF ONLY ONE TANK AND CAUSES THE IMBALANCE OF THE GRAPE HARVESTER TOO.

FILLING MUST BE CARRIED OUT WITH THE MACHINE ON A FLAT SURFACE. ON THE SITE, BEFORE THE OPERATION, THE DOSES OR THE MIXTURES TO BE Poured INTO THE TANK MUST BE PREDISPOSED.



IT IS NECESSARY TO ALWAYS MAKE USE OF PERSONAL PROTECTION.

7.1 - FOREWORD - USE OF THE FAN DISENGAGEMENT



The disconnection of fan allows you to maintain the operation of pumps (P4) and (P19) excluding the operation of the fan and airflow. This condition is useful for keeping the agitation of the mixture while moving from the place of filling to the place of treatment.

7.1.a Disengagement of the fan (or the version where foreseen)

EXECUTION:

1. Stop the grape harvester, remove the key from the control panel and check that the fan has stopped.
2. Unscrew the nut that fix the protection mobile cover and turn it to enter the release tunnel.
3. Fully press the spring push button and pull the front element until it springs out. The body disengaged from the retaining joint must turn freely: the pump will operate and the fan will thus be excluded.

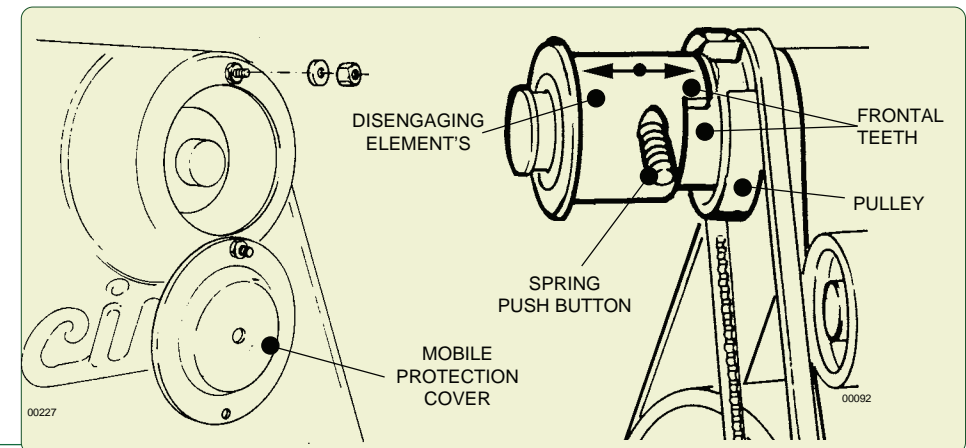

The Distribution devices (heads), employed on SPIDER sprayer assure a perfect covering, always answering to the real requirements of the culture to be treated. All the heads can be very easily oriented and regulated, so to optimise the necessary covering.

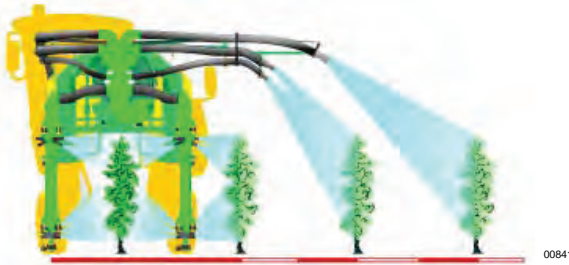

TC.8M6C - Cover 4 rows - distance between the rows 1.80 ÷ 2.00 meters



TC.8M4C - Cover 3 rows - distance between the rows 2,00 ÷ 2,60 meters

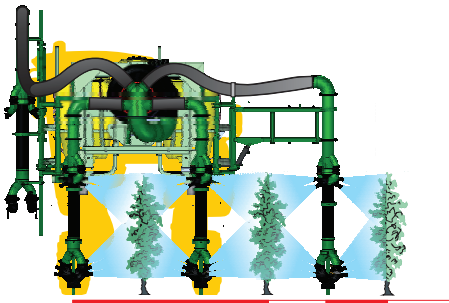

TC.16M - Cover 4 rows - distance between the rows 1,80 ÷ 2,00 meters

The possibility to change the distance among the sprayers together with the ability to change the position of the servo-fan multiplier allows you to use the SPIDER sprayers with distances inter-rows from 1.80 to 2.60 meters and with plants growing in height up to 2.5 meters. For the flow rate determination refer to the publication "The low volume-instructions for adjusting the sprayer".

4.5 - TECHNICAL DATA

4.5.1- Sprayer dimensions and weights

Main tanks, total capacity 2000 litres
 Spray-line washing tank capacity 100 litres

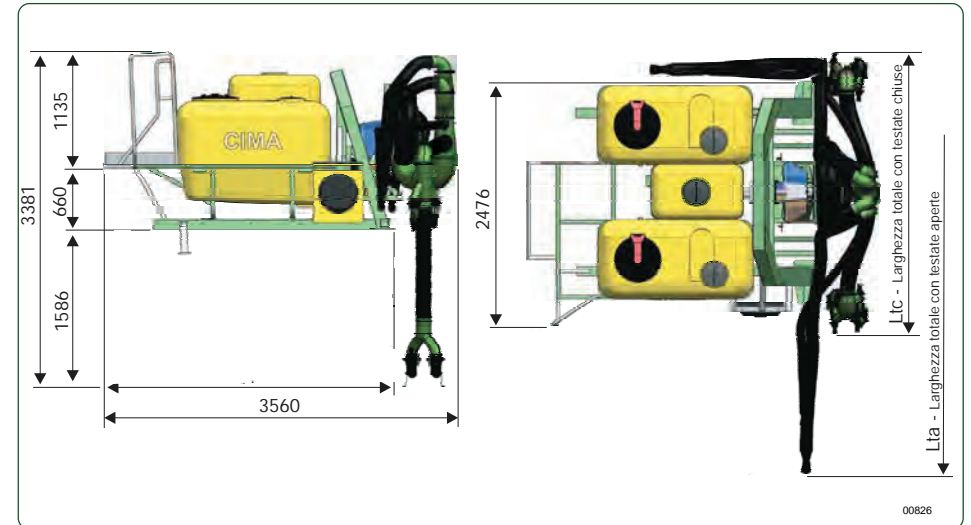

Ltc (Width with sprayhaed closed):

- T8M4C ~ 2850 mm
- T8M6C ~ 2850 mm
- T16M ~ 2950 mm

Lta (Width with sprayhaed open)

- T8M4C ~ 2850 mm
- T8M6C ~ 2850 mm
- T16M ~ 2950 mm

Height (from the grape harvester base plane)) ~ 1586 mm

Weight, empty (without sprayhead) ~ 1009kg

Total weight in operative conditions (without sprayhead) ~ 3030kg

Weight of sprayhead:

- T.8M4C (4 hand at 2 nozzles, 4 hand at 3 nozzles, 4 flex. cannons) ~ 165kg
- T.8M6C (4 hand at 2 nozzles, 4 hand at 3 nozzles, 6 flex. cannons) ~ 180kg
- T.16M (8 hand at 2 nozzles, 8 hand at 3 nozzles) ~ 398kg

4.5.2 - Fan and pump -Technical Data

Fan	50	55
Fan, construction material	Steel	Steel
Fan diameter	500mm	550mm
Fan carter, construction material	Polyetilene	Polyetilene
Fan speed	4000 RPM	3500 RPM
Air delivery	7550 m ³ /h	12500 m ³ /h
Air speed	175m/s	150m/s
Sprayer absorbed power	24kW	26kW
Internal diameter of fan outlet	175mm	250 mm
PTO shaft	1"3/8 SAE (DIN 9644/A)	1"3/8 SAE (DIN 9644/A)
Main pulley diameter	480 mm	480 mm
Fan belt	690 J50	690 J50
Fan pulley diameter	64,5mm	75 mm
Pump belt	3V 500	3V 500

Centrifugal Pump CD32

Model C.I.M.A. CD32 - Grid/filter on suction - Drain plug - Filler for the connection of the filling pipe, with plug with chain.

Activated with trapezoid belt driven by the pulley mounted on the fan shaft.

Technical data printed on the body of the pump.

— Speed	4250 RPM
— Flow rate	140 litres/min.
— Suction filter	7 mm
— Maximum pressure	4,5 Kg/cm ²
— Power absorbed	kW 2,1



The performance specified is obtained with the drive outlet (PTO) at 540 RPM For a good result of the treatments this condition **MUST ALWAYS BE OBSERVED** during the machine's operation. Utilisation is permitted with speed rates ranging between 500 and 620 RPM.

5.5 - INSTALLATION OF REMOTE CONTROLS

- 1 - Remove the electric control unit from the anchoring bracket near the filter on the sprayer.
- 2 - Fix the fastening bracket near to the driver (if not already available on the grape harvester cab) and insert the bayonet support of the control panel in the securing clamp.

ELECTRIC CONTROL UNIT

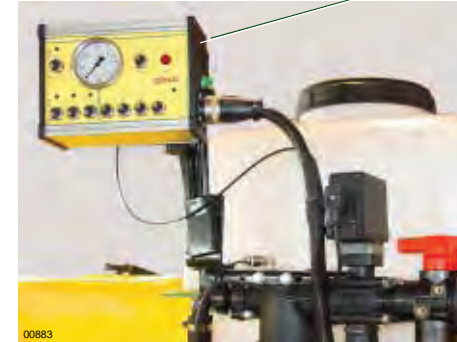

Storage position



Working position

5.4 - SPRAYER ELECTRICAL CONNECTION

The electrical connection of the SPIDER sprayer to the grape harvester self-propelled consists of three separate cables:

- power supply cable of cooler unit ;
- power supply cable of PTO tachometer ;
- power supply cable of electro-hydraulic control unit.

5.4.1. Cooler unit

Make the electrical connection of cooler following the instructions on the manual "Installation instructions for 45CV PTO" .

5.4.2. PTO tachometer

Make the electrical connection of tachometer of the PTO following the instructions on the manual "Installation instructions for 45CV PTO" .

5.4.3. Electrical control panel.



Stop the grape harvester, remove the key from the control panel, and make sure that nobody can act on, before making the electrical connection.

The electrical control unit is equipped with a connector for cigarette lighter socket. Connect the cable from the electrical control unit to the cigarette lighter socket of the grape harvester self-propelled.

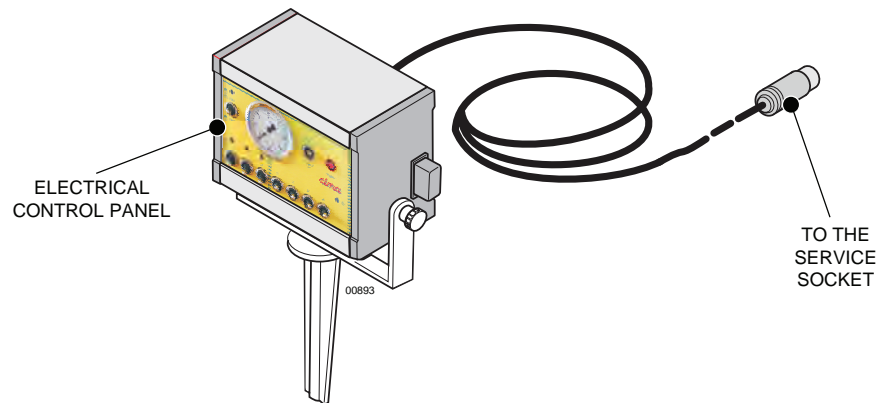

5.1 - INSTALLATION ON THE GRAPE HARVESTER



The grape harvester hydraulic power, under all utilisation conditions, must provide a power exceeding that absorbed by the sprayer.



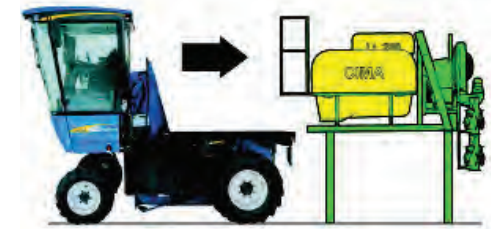

Atomizer-grape harvester coupling must be performed after removing the harvest appliance (see "Use and Maintenance manual" - grape harvester), on a plane surface, after having checked that all the people not charged with the operation moved away, as well as the children and the animals if present.

1. Start the polyvalent grape harvester and bring it under the sprayer with support bases next to the flanges coupling of the machine.
2. Raise the grape harvester to release the 4 support stands (2 front internal, 2 rear external).



00587-B

3.   **Stop the grape harvester, remove the key from the control panel, and make sure that nobody can act on.**
AVOID TO OPERATE AND STOP UNDER THE MACHINE OR ON THE AREA THAT COULD BE INVOLVED BY ITS SUDDEN DROOP.
4. Lock the sprayer from the rear side by the coupling flanges(or coupling cones) with relevant screws and nuts.



00877

REAR
COUPLING FLANGE

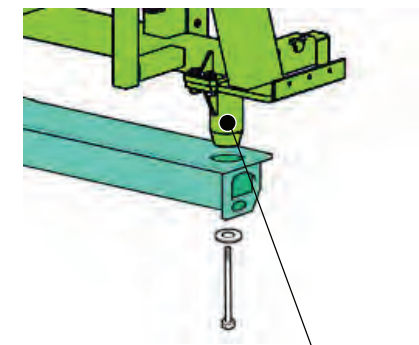

REAR
COUPLING CONE

5. Insert the two front tie rods and tighten the relevant nuts.



5.2 - HYDRAULIC SUPPLY CONNECTION

All hydraulic parts, pipe, fittings, caps lock, cooling units and hydraulic motor, are part of the "Kit PTO" NEW HOLLAND supply. The CIMA S.p.A declines any responsibility resulting from malfunction, damages or breakages. All pipes shall be interfaced with the hydraulic system of polyvalent grape harvester following the directions on the manual "Installation instructions for 45CV PTO".

5.3 - HYDRAULIC SUPPLY CONNECTION FOR SPRAYHEAD MOVEMENTS

For sprayhead hydraulic movement they normally use the connections to the ascent and descent of buckets collecting right and/or left that are located on the rear part of the front left wrap-a-round.

5.3.1 - Connection

Hydraulic piping connection must be associated with the diagram of the links provided for the use of accessories (cfr. "Maintenance manual and use" - grape harvester)

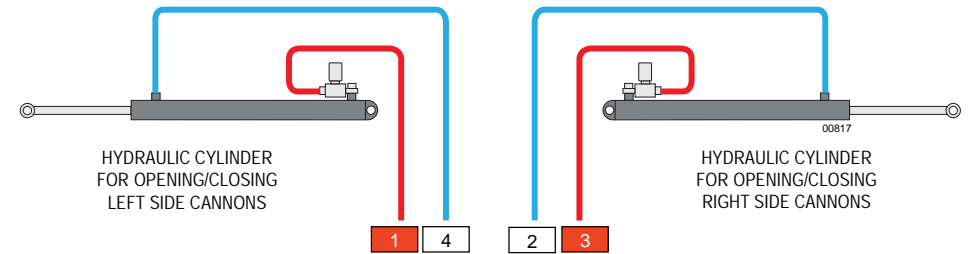
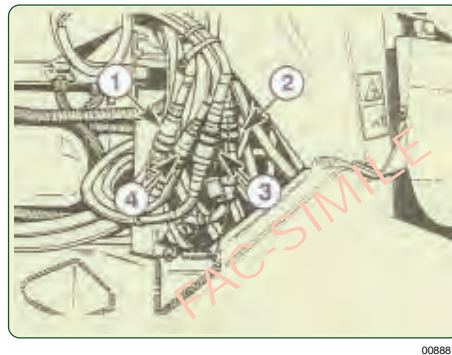

Hydraulic diagram T.8M4C e T.8M6C sprayheads movement

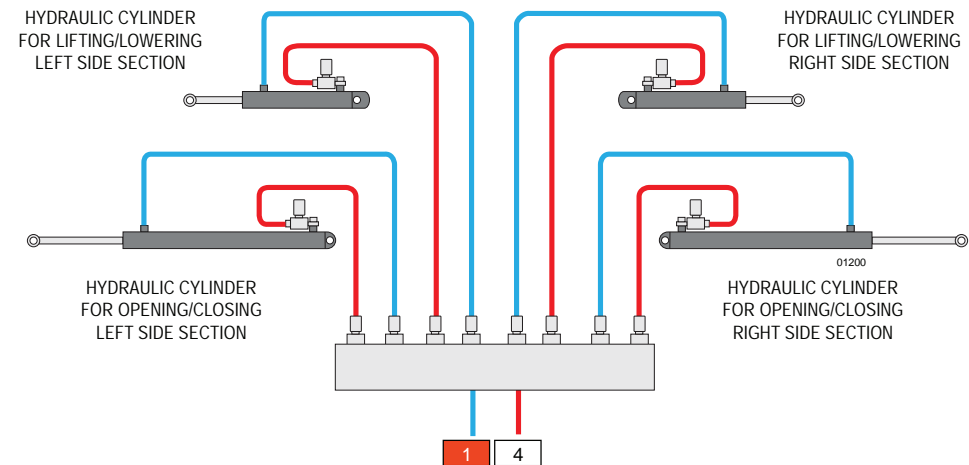

Hydraulic diagram T.16M sprayheads movement

1. Stop the grape harvester, remove the key from the control panel, and make sure that nobody can act on.

Before making any connection/removal of the pipes it must make sure that the circuit IS NOT under pressure (see grape harvester manual 'Maintenance and use'). A leak of oil under pressure can cause serious injuries. Avoid contact with skin, eyes and mouth: always use the means of personal protection: screens, glasses, gloves, etc.. Near of the operational area prepare a suitable vessel for collecting any hydraulic oil spills. Encircle any leaks with sand or other absorbent material appropriate and collect all the oil: for disposal follow the rules in force in the country of use.

2. Remove the protective plug from the hose and the corresponding socket on the plate.
3. Connect the hose at the connection (1) for the flexible hose of bucket swing collection.
4. Continue with subsequent tubes until completion.

After completing all hydraulic connection of the sprayer, check the hydraulic oil level (cfr. "Maintenance manual and use" - grape harvester)