



S420 - S430 €  
S520 - S530 €

## OPERATION AND MAINTENANCE INSTRUCTIONS

**cima**® S.p.A.

27040 Montù Beccaria - Loc. Molino Quaroni - (PV) - ITALIA  
Tel. +39.0385.246636 r.a. - Fax +39.0385.246637

<http://www.cima.it>

**cima**®

**atomizzatori e impolveratori**

Dear Customer, thank you very much!

We want to congratulate with you, for having chosen a **cima**® Xi ghYf.

Your choice shows the wisdom of the well-informed Purchaser, aware of the fact, that the required features of quality, technique and reliability must be satisfied at the right price!

Our continuous engagement in R&D and in testing our machines allows us to realize products able to offer the best performances, a high reliability and a great easiness of use at the same time !

Our first goal, is to get our Customers happy for having met us!

The "Spare parts catalogue" of this duster is available in the "owners area" on website [www.cima.it](http://www.cima.it).

In order to accede, use:

User name: **duster**

Password: **546236NQ**

# Where we are









**GENERAL INDEX**

<b>1</b>	<b>FOREWORD</b> .....	<b>1</b>
1.1	PUBLICATION IDENTIFICATION .....	1
1.2	ATTACHED PUBLICATIONS .....	1
1.3	PURPOSE OF PUBLICATION .....	1
1.4	REFERENCE TO REGULATIONS .....	1
1.5	USING THE MANUAL .....	1
1.6	UPDATES .....	2
<b>2</b>	<b>GLOSSARY</b> .....	<b>2</b>
2.1	TERMINOLOGY .....	2
2.2	ABBREVIATIONS .....	3
2.3	DECALS .....	3
<b>3</b>	<b>GENERAL INFORMATION</b> .....	<b>5</b>
3.1	MACHINE IDENTIFICATION .....	5
3.2	TECHNICAL ASSISTANCE .....	5
3.3	SAFETY NOTICES .....	5
3.4	SAFETY SYSTEMS .....	6
3.5	HANDLING OF AGRO-CHEMICALS .....	7
3.5.1	STORAGE .....	7
3.5.2	SPECIFIC EQUIPMENT .....	7
3.5.3	DISPOSAL OF EMPTY CONTAINERS AND AGRO-CHEMICALS RESIDUES .....	7
3.5.4	PERSONAL MEANS OF PROTECTION .....	8
<b>4</b>	<b>MACHINE'S STRUCTURAL ANALYSIS</b> .....	<b>9</b>
4.1	FRAME .....	10
4.2	MULTIPLIER .....	10
4.3	FAN .....	11
4.4	TANK BOTTOM .....	11
4.5	TANK .....	11
4.6	CAPACITY REGULATOR .....	11
4.7	TECHNICAL DATA .....	12
<b>5</b>	<b>COUPLING MODALITIES</b> .....	<b>13</b>
5.1	HITCHING TO THE TRACTOR .....	13

**18 ATTACHMENT: DECLARATION OF COMPLIANCE 18**



<b>DICHIARAZIONE DI CONFORMITÀ</b>				
ai sensi della direttiva 98/37/CE del 22/06/98 e successive modificazioni				
<b>DECLARATION OF CONFORMITY</b> as directive: 98/37/CE - 22/06/98 and subsequent modifications			<b>DECLARATION DE CONFORMITE</b> selon la directive 98/37/CE - 22/06/98 et modifications ultérieures	
<b>ÜBEREINSTIMMUNGS-ERKLÄRUNG</b> lt. Direktiven 98/37/CE - 22/06/98 und nachfolgenden Änderung			<b>DECLARACION DE CONFORMIDAD</b> con arreglo a la Directiva 98/37/CE - 22/06/98 y modificaciones siguientes	
<b>CIMA s.p.a. 27040 MONTÙ BECCARIA (PV) - ITALY - Loc. Molino Quaroni</b>				
DICHIARA SOTTO LA PROPRIA RESPONSABILITÀ CHE LA MACCHINA:	HEREWITH DECLARES, UNDER THEIR PERSONAL RESPONSIBILITY, THAT THE FOLLOWING MACHINE:	DECLARONS SOUS NOTRE RESPONSABILITE QUE LA MACHINE DECRITE CI-APRES:	BESTÄTIGT HERMIT UNTER IHRE PERSONLICHEN VERANTWORTUNG DAS DIE MASCHINE:	DECLARA BAJO LA PROPIA RESPONSABILIDA QUE LA MAQUINA:
SERIE, TIPO - MODEL, TYPE - SERIE, TYPE - MODEL, TYP - SERIE, TIPO:				
<input style="width: 100%; height: 20px;" type="text"/>				
MATRICOLA - SERIAL - MATRICULE - SERIAL - MATRICULA NR.:				
<input style="width: 100%; height: 20px;" type="text"/>				
E' conforme ai Requisiti essenziali di Sicurezza e di Tutela della Salute di cui alla Direttiva 98/37/CE del 22/06/98 e sue successive modificazioni. Per la verifica della Conformità di cui alle Direttive sopra menzionate, sono state consultate le seguenti: Norme armonizzate: <b>EN 294</b> <b>EN 349</b> <b>EN 907</b> .				
Conforms to the essential Safety regulation as well as the Health requirements as per European Economic Community Directive: 98/37/CE - 22/06/98 and subsequent modifications. For the verification of conformity as per above mentioned directives the following official EN norms have been consulted: Harmonized norms: <b>EN 294</b> <b>EN 349</b> <b>EN 907</b> .			Est conforme aux exigences de Sécurité et de Sauvegarde de la Santé dont à la Directive 98/37/CE - 22/06/98 et modification ultérieures. Pour vérifier la conformité aux directives susmentionnées, ont été prises en compte les normes suivantes: Normes harmonisées: <b>EN 294</b> <b>EN 349</b> <b>EN 907</b> .	
Stimmt mit den wesentlichen Requisiten der Sicherheitsvorschriften und der Gesundheitsvorsorge lt. EWG Direktive Nr. 98/37/CE - 22/06/98 und nachfolgenden Änderungen überein. Für die Überprüfung dieser Übereinstimmungs-Erklärung lt. obigen Direktiven sind folgende Normen konsultiert worden: Normen: <b>EN 294</b> <b>EN 349</b> <b>EN 907</b> .			Cumple con los requisitos esenciales de Seguridad y de Preservación de la Salud contenidos en la Directiva 98/37/CE - 22/06/98 y modificaciones siguientes. Para comprobar la conformidad a la que se refieren las Directivas anteriormente citadas, se han consultado las siguientes: Normas Armonizadas: <b>EN 294</b> <b>EN 349</b> <b>EN 907</b> .	
Responsabile della Sicurezza - The Security Official - Responsable Sécurité et Homologations - Der Sicherheits-Beamter - Responsable de la Seguridad				
Montù Beccaria (PV) Data, Date, Date, Datum, Fecha, _____				Smeraldi Paolo 

**LqA**, Observed equivalent average sound level, expressed in dB(A)=:

Esse 420-430 = **90,2 ± 0,2**  
 Esse 520-530 = **98,2 ± 0,2**



**THE OWNER AND/OR THE OPERATOR OF THE DUSTER ARE NOT PERMITTED TO MODIFY THE STRUCTURE OR THE SPECIFIC OPERATION OF THE DUSTER ITSELF. ANY REPAIRING INTERVENTION HAS TO BE CARRIED OUT EITHER AT THE DISTRIBUTORS' OR AT THE C.I.M.A. S.p.A. AUTHORIZED WORKSHOPS, OTHERWISE ANY KIND OF WARRANTY IMMEDIATELY CEASES AND C.I.M.A. S.p.A. IS CLEARED OF ANY CONSEQUENT AND/OR IMPLIED RESPONSIBILITY.**

The machines are guaranteed for **12 months** from the delivery date. During this period, spare parts not subject to wear and tear and confirmed as defective will be replaced free of charge, not including of transport and labour expenses.

The warranty will be void:

- a. should repairs be carried out without the consent of the manufacturer or one of its sale points.
- b. should original spares not be used.
- c. should the machine be used for purposes other than those for which it was specifically designed and destined.
- d. should the instructions of this manual, together with those relating to the integrative parts that make it up, not be observed.

5.2	MOUNTING OF THE TRANSMISSION SHAFT .....	14
5.3	INSTALLATION OF CAPACITY REGULATOR CONTROL LEVER .....	15
<b>6</b>	<b>DISTRIBUTION DEVICES</b> .....	<b>15</b>
<b>7</b>	<b>ACCESSORIES</b> .....	<b>17</b>
7.1	PAIR OF WHEELS .....	17
<b>8</b>	<b>FILLING</b> .....	<b>18</b>
<b>9</b>	<b>CONSTANT DELIVERY CONTROL</b> .....	<b>18</b>
<b>10</b>	<b>OPERATING PROCEDURES</b> .....	<b>19</b>
10.1	PRELIMINARY OPERATIONS TO TREATMENT .....	19
10.2	PREPARATORY OPERATIONS TO TREATMENT .....	20
10.3	THE TREATMENT .....	20
10.4	END OF TREATMENT - STORAGE .....	21
10.4.1	DAILY .....	21
10.4.2	END OF SEASONAL CYCLE .....	21
<b>11</b>	<b>LIFTING AND TRANSPORT</b> .....	<b>21</b>
11.1	LIFTING AND TRANSPORT OF THE DUSTER .....	22
<b>12</b>	<b>MAINTENANCE OPERATIONS</b> .....	<b>22</b>
12.1	GREASING .....	22
12.2	LUBRICATION .....	23
<b>13</b>	<b>TROUBLE SHOOTING</b> .....	<b>24</b>
<b>14</b>	<b>REPAIRS ALLOWED</b> .....	<b>24</b>
<b>15</b>	<b>INTEGRATIVE DIAGRAMS</b> .....	<b>25</b>
15.1	DUSTER DIAGRAM .....	25
<b>16</b>	<b>NOISE LEVEL</b> .....	<b>26</b>
<b>17</b>	<b>WARRANTY</b> .....	<b>26</b>
<b>18</b>	<b>ATTACHMENT: DECLARATION OF COMPLIANCE</b> .....	<b>27</b>

15.1 - DUSTER DIAGRAM

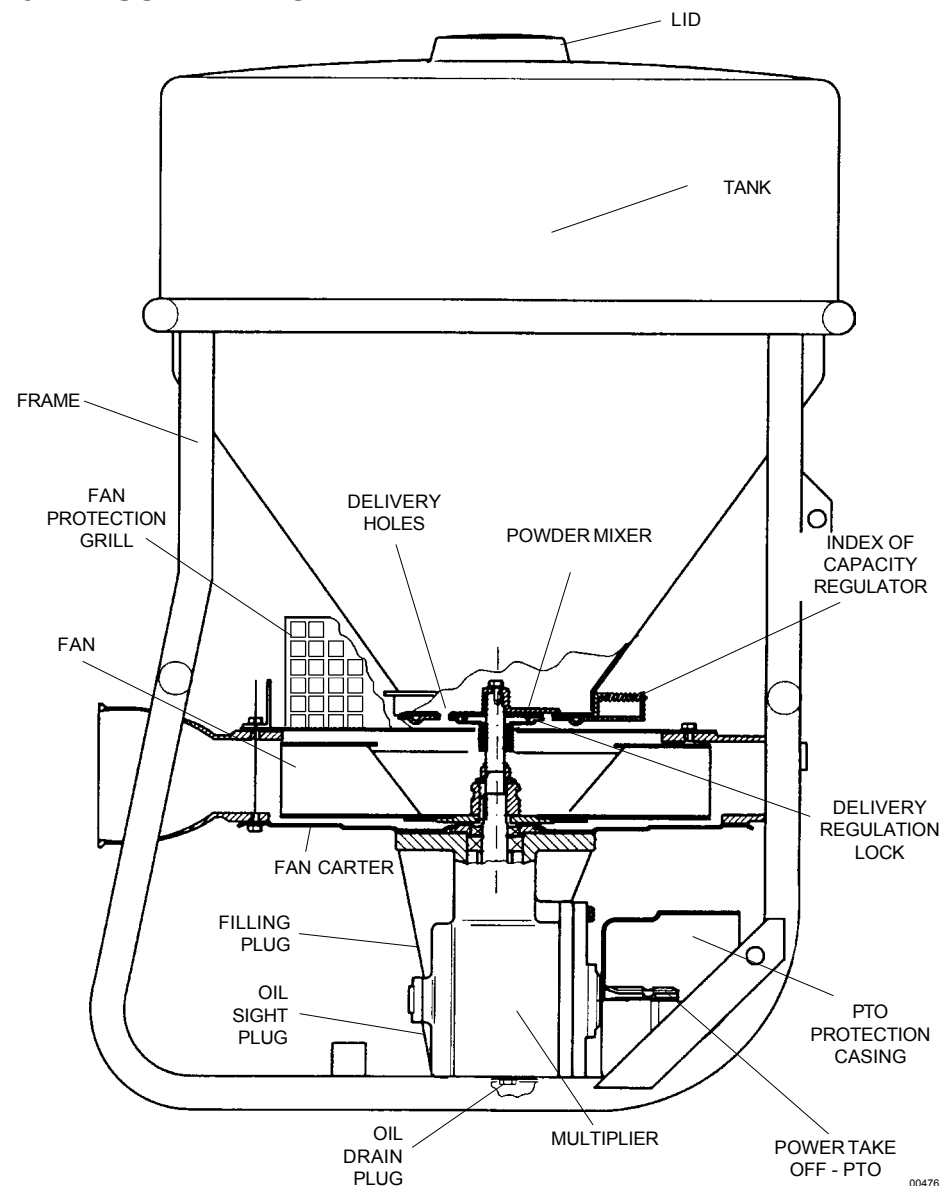



**A. PROBLEM: Oil leakage from the cover of the multiplier box**

1. CAUSE: The cover seal is defective.  
**REMEDY:** Refer to CIMA after sale service.
2. CAUSE: The sealing ring on the cover is defective.  
**REMEDY:** Refer to CIMA after-sale service.

**B. PROBLEM: Vibration of the ventilator group**

1. CAUSE: The fan is dirty or out of balance.  
**REMEDY:** Refer to CIMA after-sale service.
2. CAUSE: The PdPs are not aligned or are not parallel.  
**REMEDY:** Position the PdPs in the correct way.

**C. PROBLEM: Abnormal and constant noise with vibrations**

1. CAUSE: Breakage of the multiplier bearings.  
**REMEDY:** Refer to CIMA after sale service.

**D. PROBLEM: Non-delivery of powders**

1. CAUSE: The feeding holes on the tank bottom are clogged.  
**REMEDY:** Clean them.
2. CAUSE: Caking of the tank's contents.  
**REMEDY:** Break up the powder.

**E. PROBLEM: Distribution on the two sides is not uniform**

1. CAUSE: The compensation plate of the head has moved.  
**REMEDY:** Adjust it in order to get a uniform distribution.



**THE OWNER AND/OR THE OPERATOR OF THE DUSTER ARE NOT PERMITTED TO MODIFY THE STRUCTURE OR THE SPECIFIC OPERATION OF THE DUSTER ITSELF. ANY REPAIRING INTERVENTION HAS TO BE CARRIED OUT EITHER AT THE DISTRIBUTORS' OR AT THE C.I.M.A. S.p.A. AUTHORIZED WORKSHOPS, OTHERWISE ANY KIND OF WARRANTY IMMEDIATELY CEASES AND C.I.M.A. S.p.A. IS CLEARED OF ANY CONSEQUENT AND/OR IMPLIED RESPONSIBILITY.**

**1.1 - PUBLICATION IDENTIFICATION**

The "OPERATION AND MAINTENANCE INSTRUCTIONS" manual is an integrative part of the dusters. It is identified by a Publication No. located on the frontispiece, and through which the document can be identified, traced and/or subsequently referred to.

The information elements contained herein are updated as at the date of publication. C.I.M.A. S.p.A. reserves the right to modify its machines without notice, with the purpose of applying technical enhancements, and it declines all responsibility for possible omissions from the publication.

All rights are reserved. No parts of this book may be reproduced or utilized in any form or by any means, electronic or mechanical, including photocopying, recording, or by any information storage and retrieval system, without permission in writing by C.I.M.A. S.p.A.

**1.2 - ATTACHED PUBLICATIONS**

- Spare parts catalogue;

**1.3 - PURPOSE OF PUBLICATION**

All indications contained in this manual are aimed at the user of the duster.

The duration of the machine and its operation, the operator's safety and the respect for the environment are dependent upon scrupulous observance of the stated norms.

Before making use of the duster, the user must read, understand and abide by all regulations listed in this manual.

**1.4 - REFERENCE TO REGULATIONS**

This manual was set out conforming to the regulations contained in following documents:

- Attachment "I" to Directive 89/392/C and subsequent modifications (letters "b", "c" of point 1.1.2 and point 1.7.4);
- UNI EN 907 - 1997 and to all the documents in it quoted.

**1.5 - USING THE MANUAL**

Read every part of this manual, paying attention to the **WARNING** and **DANGER** indications both on the text and on the machine or on components.

All operations suggested by the manual will have to be followed with the utmost care and only after having understood the negative consequences of improper usage.

The following "symbols" are used within the text in order to highlight and visually identify the importance of the various types of information:



Indicates important additional information





Non observance can result in permanent damage to the duster.



Highlights possibly dangerous situations to people.

The manual, with relevant attachments and possible integrating issues, must be kept with the utmost care and must always be complete, integer and legible in every part. Should it be mislaid it is imperative to immediately request a duplicate from C.I.M.A. S.p.A. Should the decals originally applied on the machine be mislaid, damaged or become incomprehensible, they should be promptly replaced.

-  - The manual must always be kept for the duster's whole operational life.
-  - Any modification received must be permanently inserted in this publication.
-  - The manual must be ceded with the duster should this be sold.

## 1.6 - UPDATES

Possible updates that C.I.M.A. S.p.A. will provide the owner of the duster will be accompanied by instructions to insert in this publication.

Should the machine be sold, the owner must inform the new purchaser that he should notify C.I.M.A. S.p.A. of his address in order to receive possible future integrating issues and/or updates.

# 2 GLOSSARY 2

## 2.1 - TERMINOLOGY

The terms FRONT, REAR, RIGHT and LEFT utilised in this publication refer to the duster as seen by an operator from behind the operative unit along the drive line and facing it: **the rear part** of the machine is that closest to the operator, and is where the distribution device (Head) is mounted - and **the front part** is the one that gets attached to the tractor.

## 2.2 - ABBREVIATIONS

cm	.....	centimetres
g	.....	grams
h	.....	hour
ha	.....	hectare
ha/h	.....	hectare per hour
HP	.....	horse power
l	.....	litres
l/h	.....	litres per hour
l/min.	.....	litres per minute
kg	.....	kilogram
kg/cm <sup>2</sup>	.....	kilograms per square centimetre (atmosphere)
km	.....	kilometre
km/h	.....	kilometres per hour
kW	.....	kilowatt
Lm	.....	width in metres
m	.....	metre
m <sup>3</sup> /h	.....	cube metres per hour
m/s	.....	metres per second
Mesh	.....	N° of meshes per linear inch
Micron	.....	1/1000 of millimetre

## 12.2 - LUBRICATION

 **When the machine is sitting on a flat surface, the oil level inside the multiplier should always be visible through the sight plug situated on the guard cover.**

The multiplier oil has to be replaced after **1000 working hours**. A plug situated under the multiplier box allows for the discharge of the oil.

It is absolutely necessary that the oil is always kept at the required level. Any possible filling up has to be carried out through the filling cap, either by inclining or by laying down the machine: **always use oil SAE 90.**

 **At the beginning of the treatment season and before every intervention, check the oil level in the multiplier guard.**

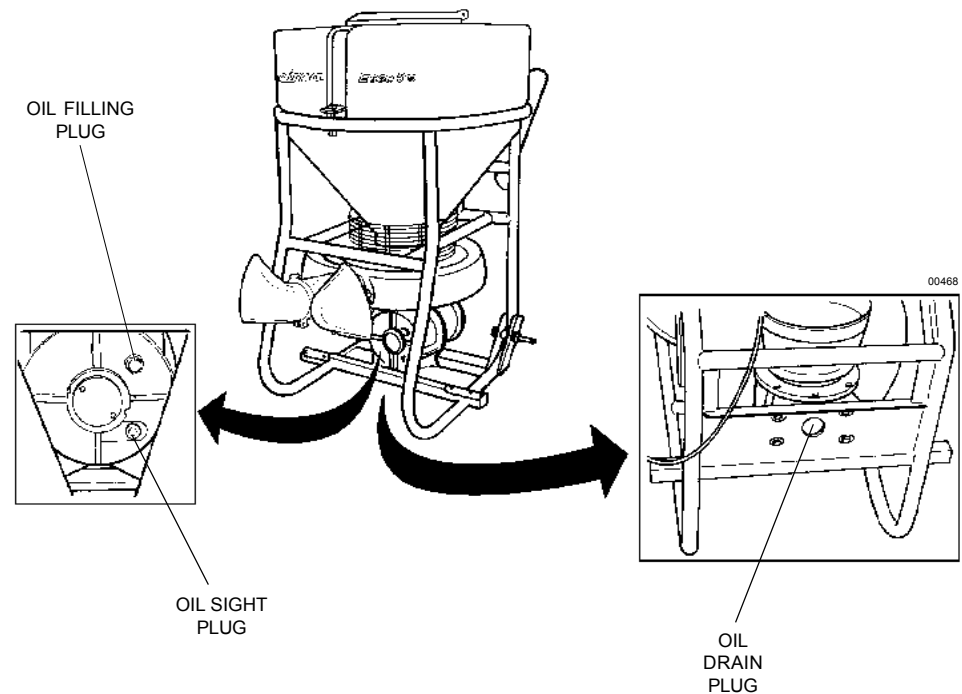

## 11.1 - Lifting and transport of the duster

 Before carrying out any operation it is essential to verify that no product residues are left in the tank.

1. Check that the cables or chains used for the lifting are adequate for the weight to be lifted.
2. Hook the machine through the specific support point indicated by the specific decal on the frame, checking all the parts involved in the operation.
3. Lift the machine, verifying that it is properly balanced; position the duster on the transporting vehicle in perfectly stable conditions.
4. During transport the machine must be immobilised and fastened to the carrier by way of suitable strapping. un'imbragatura adeguata.

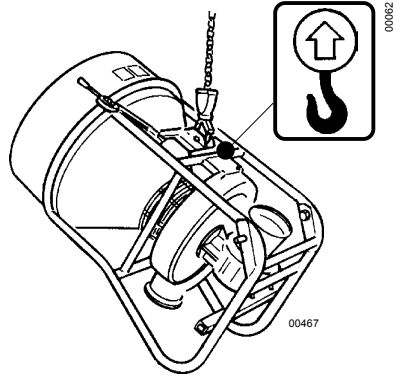

## 12 MAINTENANCE OPERATIONS 12

  ALL OPERATIONS MUST BE CARRIED OUT WITH THE ENGINE SWITCHED OFF AND WITH THE IGNITION KEY REMOVED FROM THE CONTROL PANEL.

### 12.1 - GREASING

At the beginning of the treatment season and after every 50 hours work, grease the felt seal with EP type NGL2 class grease.

 - Accurately clean the greaser before use: dirt could be introduced together with grease.

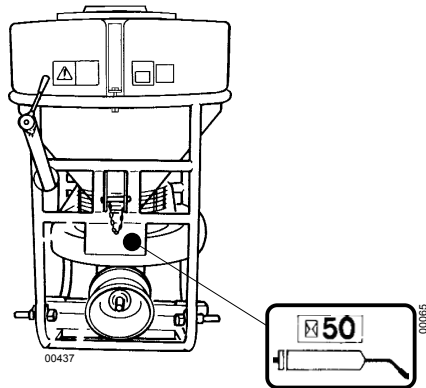

m m ..... millimetre  
 PTO ..... power take-off  
 RPM ..... revs per minute  
 s ..... seconds

## 2.3 - DECALS

The safety and use/maintenance decals applied to the machine are described in the following paragraph.

 Every decal is marked with its part number, in case it needs to be replaced.

- 1 - 95001 - **STOP THE ENGINE AND REMOVE THE KEY FROM THE TRACTOR'S CONTROL PANEL BEFORE CARRYING OUT ALL MAINTENANCE OR REPAIR OPERATIONS**  
 - Positioned on the tank in the forward part of the machine.
- 2 - 95011 - **DANGER: ROTATING COMPONENTS. BEFORE LIFTING THE LID, STOP THE TRACTOR, TAKE THE KEY OUT OF THE CONTROL PANEL AND MAKE SURE THAT ALL COMPONENTS HAVE STOPPED.**  
 - Position: on the tank, rear part of the machine.
- 3 - 95005 **DANGER, PARTS IN MOTION. BEFORE REMOVING PROTECTION GUARDS, STOP THE TRACTOR, REMOVE THE KEY FROM THE TRACTOR'S CONTROL PANEL AND ENSURE THAT ALL MOVING PARTS HAVE STOPPED**  
 - Position: on the cone-like part of the tank, rear part of the machine.
- 4 - 95006 - **WARNING: CONSULT THE USER AND MAINTENANCE MANUAL BEFORE USING OR INTERVENING ON THE MACHINE**  
 - Position: on the lid of the tank.
- 5 - 95010 - **MAXIMUM OPERATING SPEED OF THE DRIVE OUTLET (PTO): 540 RPM**  
 - Positioned on the tank in the forward part of the machine.

## Use and maintenance

- 6 - 95059 - **HOOKING POINT FOR THE LIFTING OF THE MACHINE**  
 - Position: left front part of the frame, under the third point.
- 7 - 95068 - **SOFTLY ENGAGE THE PTO; FAN START-UP MUST BE GRADUAL.**  
 - Position: on the tank, front part of the machine.
- 8 - 95053 - **GREASE EVERY 50 HOURS: FELT POWDER SEAL**  
 - Positioned upper of the fan carter, in the forward part of the machine
- 9 - 96105 - **DELIVERY GRADUATION**  
 Positioned on the duster's right side, near the delivery lock position indicator.

**Positioning of the safety, use and maintenance decals**

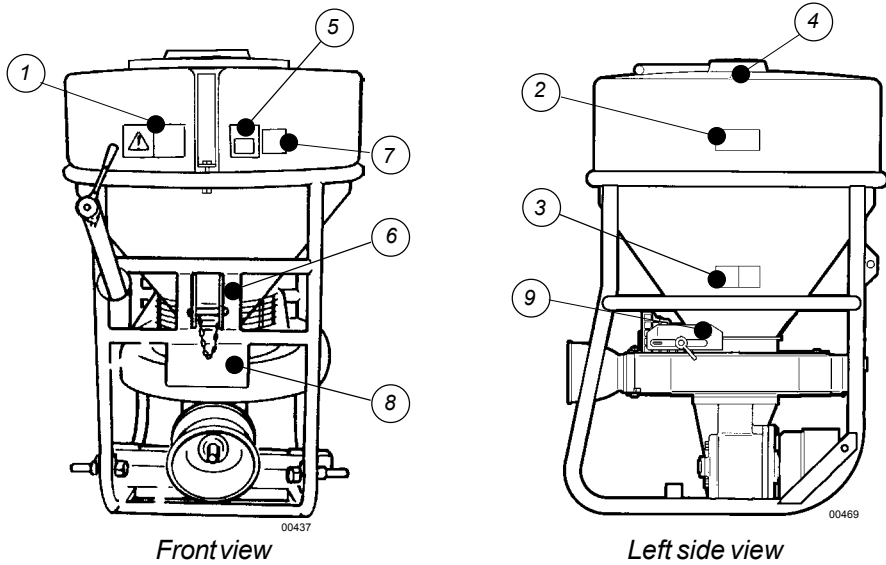

**\* Safety decals**

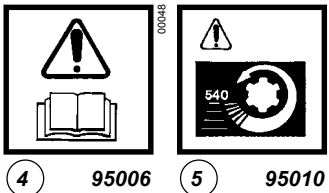
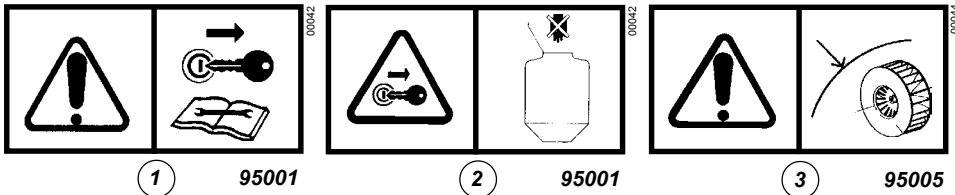

**\* Use and maintenance decals**

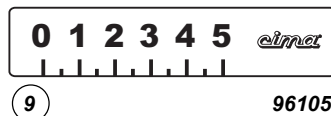
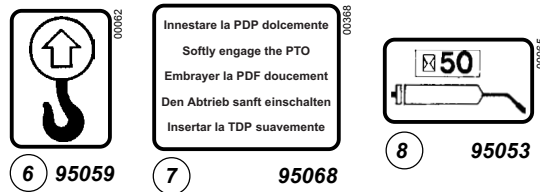

The duster should work with PdP at 540 RPM. For a good result of the treatments this condition **MUST ALWAYS BE OBSERVED** during the machine's operation. Utilisation is permitted with speed rates ranging between 500 and 620 RPM.

3. Use personal protection identical to that advised for the mixture, preparation and loading, if the tractor does not have a pressurized cab with aeration filters.
4. Immediately wash all elements contaminated during the treatment, promptly take off the contaminated protection clothes and discontinue the job if these cannot be replaced.
5. If the wind increases, follow the instructions given in the preliminary operations.
6. During the pauses, stop the motor, take the key out of the control panel of the tractor and lower the hoist.
7. Pay special attention when doing treatments near property lines, houses, waterways, roads or public paths.

**10.4 - END OF TREATMENT - STORAGE**

**10.4.1 - Daily**

The operator must:

1. Keep the machine in a ventilated place, sheltered from rain or sun: sunrays are the worst enemies of plastic and rubber parts.

**10.4.2 - End of seasonal cycle**

The operator must:

1. Carry out an accurate cleaning of the duster, emptying the tank and the distribution holes of any product residue. The operation must be done without the use of water or liquid detergents.
2. Check to see if the machine's parts and structures are working correctly. In the case of negative results, ask for the intervention of C.I.M.A. S.p.A. dealer or authorized workshop.
3. Put the machine in a ventilated place, sheltered from rain, ice and rays of sun.

**11 LIFTING AND TRANSPORT 11**



THE FOLLOWING ACTIONS ARE NOT ALLOWED:

- Transporting or lifting the duster with residual quantities of product in the tank for purposes differing from its destined usage.
- The transporting of people, animals or things.
- The trailing of vehicles or equipment.



Road transport must take place in the complete observance of road regulations in force in the Country where the machine is used.

- When the footprint of the duster exceeds that of the tractor, the specific notice sign for overhanging loads needs to be attached on the rear.
- It is necessary to replicate the tractor's number plate and tail lights when these are covered by the machine.  
The operator is responsible for possible defaults due to the non observance of said regulations.

## 10.2 - PREPARATORY OPERATIONS TO TREATMENT



IT IS ALWAYS NECESSARY TO WEAR PERSONAL PROTECTION CLOTHING AND ACCESSORIES. The powdering masks do not offer any protection against toxic vapors. Avoid using clothes that can get caught in the moving elements.



Before opening the lid, ALWAYS check that the tractor is STILL and that the key was REMOVED from the control board.

1. Carry out all checking and maintenance operation necessary for setting up the machine.
2. Perform loading in a well-ventilated place. If this is done outdoors, the presence of wind increases the danger of contamination.
3. Avoid proximity of free flames, coals or burning objects with flammable products.
4. Put the emptied product packages in the appropriate container or in the storage rooms.
5. Clean the equipment and the tools used for preparation and keep them in the storage area for chemical products.
6. Always leave the product loading and preparation area in conditions which will not cause any contamination to persons or animals, or environmental pollution.
7. If necessary, mark the field or the machine passage area, to provide a guide for treatment and to avoid missing spots or overlapping layers.



- AT THE END OF THE OPERATIONS NECESSARY FOR TREATMENT, THE STORAGE-CONSERVATION AREAS MUST BE LEFT IN THE CONDITION REQUESTED IN ORDER TO PERFORM THEIR PREVENTIVE AND PROTECTIVE FUNCTION.  
- BEFORE RE-STARTING THE TRACTOR, CLEAR PEOPLE AND ANIMALS AWAY AND NEVER LEAVE THE MACHINE UNGUARDED DURING THE PREPARATION OPERATIONS.

## 10.3 - THE TREATMENT



Before any transferring, make sure that the powder delivery lock is CLOSED (position "0"). If the delivery lock is open and the fan is still, the powder contained inside the tank could, as a result of the vibrations, move down and compact itself inside the fan, so causing at the machine start an excessive solicitation of the moving parts, which could consequently break. As a general precaution measure, it is recommended to avoid covering great transferring distances with the loaded tank, in order to avoid the product getting compacted inside the tank.

IT IS ADVISABLE TO BEGIN TREATMENT AT THE HEADLANDS.

### The operator must:

1. Start the tractor, always observing the safety norms.
2. Activate the power take off (PTO) and take it to a rotation speed of **at least 500 RPM**. CARRY OUT THE TREATMENT



### SOFTLY ENGAGE THE PTO.

The fan must reach the status of inertia and acquire a certain rotation speed before pushing the accelerator. Transmitting most of the motor power to overcome the starting take-off may cause the breakage of the multiplier gears. Pay special attention with double-clutch tractors.

## 3.1 - MACHINE IDENTIFICATION

	<b>cima</b> S.p.A. MONTU' BECCARIA (PV) ITALY ☎ (39) 0385/246636 FAX 246637	Fabbr. nel
Tipo	[ ]	
Matr.	[ ]	Press. max bar [ ]
Peso a V. Kg	[ ]	Peso T. Kg [ ]

00070

Identification nameplate

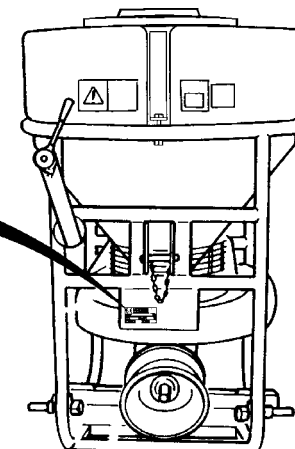

00440

## 3.2 - TECHNICAL ASSISTANCE

C.I.M.A. S.p.A. is at the complete disposal of customers for any type of intervention. The names and addresses of its service network, both in Italy and in foreign countries, can be requested from:

C.I.M.A. S.p.A. - 27040 Montù Beccaria - Loc. Molino Quaroni (PV) - ITALIA  
tel. 0385-246636 - fax 0385-246637  
from abroad tel. +39-0385-246636 - fax +39-0385-246637  
e.mail [tecnic@cimaitalia.com](mailto:tecnic@cimaitalia.com)

## 3.3 - SAFETY NOTICES

All the preparation, use, maintenance, moving and transporting operations must be carried out only after having acquired a perfect knowledge of the regulations contained in this publication and the ability to appropriately interpret the symbols of the decals applied to the machine.



IT IS FORBIDDEN TO UTILISE THE DUSTER FOR PURPOSES OTHER THAN FOR ITS INTENDED USE, AS IT HAS BEEN DEVELOPED EXCLUSIVELY FOR DISTRIBUTING ANTI-MILDEW POWDERS ON AGRICULTURAL CULTIVATIONS

It is necessary to scrupulously abide by the following general norms:

- always stop the tractor's engine before carrying out any operation on the duster;
- check that the weight and power of the tractor are compatible with the duster to be used;
- before utilisation, check the correct tightening and securing of the machine's various components, paying particular attention to the safety protections and to the moving parts;
- only utilise protected cardan shafts provided with CE conformity certification. Carry out the assembly only if the drive outlets of both tractor and duster are equipped with the protection counter-guard;
- check that the cardan shaft is blocked by the appropriate anti-rotation chains;
- keep people and animals away from the machine before starting it up;

- don't wear articles of clothing that might get caught in moving parts;
- keep to a low speed while negotiating bumps or crossing ditches.

-  - All of the maintenance and repair operations should be carried out only after having carefully cleaned all the parts of the machine.
- It is forbidden to make weldings if ammonium salts have been used or on parts not perfectly cleaned from any sulphur residuals.
  - It is forbidden to use the machine if any free flames are present or in proximity of any incandescent material, fire residuals or glowing fires.

### 3.4 - SAFETY SYSTEMS

All machine moving parts are suitably protected by guards and highlighted through the use of warning decals.

-  - It is forbidden to use the machine with these guards removed.
- Before removing the protection, stop the tractor's engine and remove the key from the control panel.
  - Before beginning the distribution of the product, make sure that the lid is closed.

The pictures illustrate the machine's guarded parts:

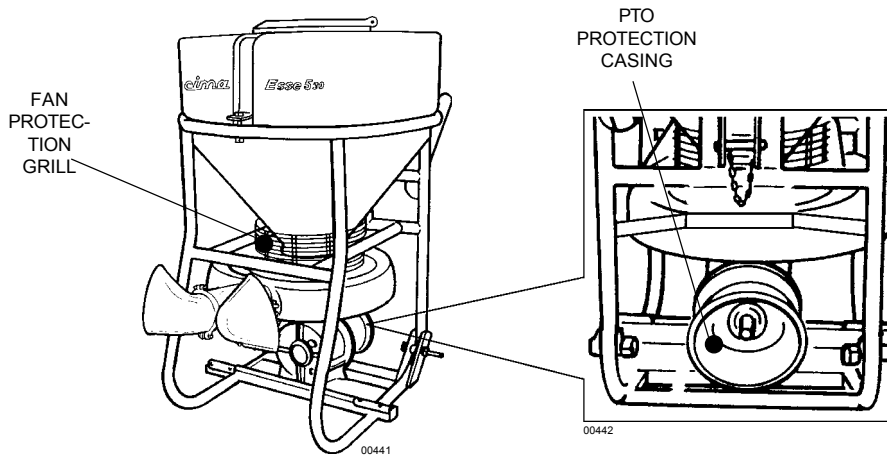

 **THE OWNER AND/OR THE OPERATOR OF THE DUSTER ARE NOT PERMITTED TO MODIFY THE STRUCTURE OR THE SPECIFIC OPERATION OF THE DUSTER ITSELF. ANY REPAIRING INTERVENTION HAS TO BE CARRIED OUT EITHER AT THE DISTRIBUTORS' OR AT THE C.I.M.A. S.p.A. AUTHORIZED WORKSHOPS, OTHERWISE ANY KIND OF WARRANTY IMMEDIATELY CEASES AND C.I.M.A. S.p.A. IS CLEARED OF ANY CONSEQUENT AND/OR IMPLIED RESPONSIBILITY.**

#### EXECUTION:

1. Using the on-off lever, find the delivery position suitable for the intervention.
2. Unscrew the locking lever and move it up to reach the delivery position indicator, then strongly lock it by completely screwing it back.  
This operation ensures the equal opening of the delivery holes during the entire treatment.

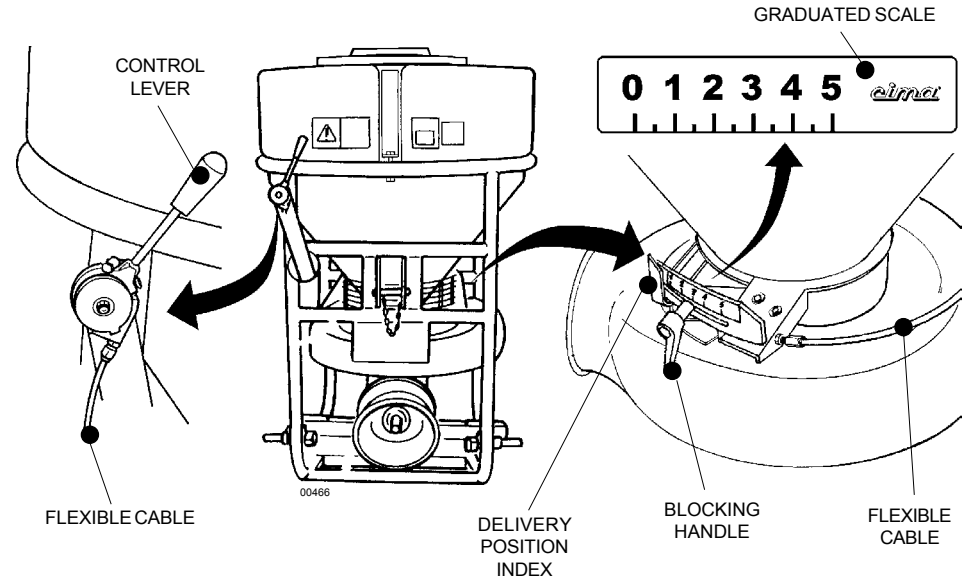

## 10

## OPERATING PROCEDURES

## 10

### 10.1 - PRELIMINARY OPERATIONS TO TREATMENT

THE OPERATOR MUST:





1. Ascertain that the condition of the crops, the progress of the disease or the need for its prevention actually justify the treatment to be applied.
2. Be aware of the meteorological conditions forecast for all the time necessary for carrying out the treatment.
3. If possible, avoid carrying out the spraying in strong wind conditions or when one detects that the sprayed product disperses away from the target crop (drifting). It is advisable to suspend the treatment when the wind speed exceeds 3 m/s (10 km/hour).
4. Carefully calculate the exact quantity of the product necessary for the treatment.
5. Check that the product is available in a quantity sufficient to complete the intervention.
6. Read the product's utilisation instructions carefully, in order to ascertain the usage conditions, the correct dosage and the expiration dates.

**FILLING MUST BE CARRIED OUT WITH THE MACHINE ON A FLAT SURFACE. ON THE SITE, BEFORE THE OPERATION, THE DOSES TO BE Poured INTO THE TANK MUST BE PREDISPOSED.**



**IT IS NECESSARY TO ALWAYS MAKE USE OF PERSONAL PROTECTION.**

EXECUTION:

1. Take the duster to the area in which it is to be filled and rest it on the ground.
2.   **Stop the tractor and remove the key from the control panel .**
3. Before filling the tank, stop delivery by bringing the control lever to the "0" position
4.   **Before opening the lid, ALWAYS check that the tractor is STILL and that the key was REMOVED from the control board.**
5. Open the lid of the tank.



**Avoid that both BEFORE and DURING the loading any foreign objects like stones, small pieces of metal, etc., are introduced into the tank. Even if small dimensioned, such objects could, by getting into contact with the mixer during its operation, cause some sparks inside the tank and set the duster on fire.**

6. Introduce the powder product into the tank, up to its complete filling.
7. Close the lid of the tank.
8. Start the tractor, always observing the safety norms and move to the treatment place.



**Before any transferring, make sure that the powder delivery lock is CLOSED (position "0"). If the delivery lock is open and the fan is still, the powder contained inside the tank could, as a result of the vibrations, move down and compact itself inside the fan, so causing at the machine start an excessive solicitation of the moving parts, which could consequently break. As a general precaution measure, it is recommended to avoid covering great transferring distances with the loaded tank, in order to avoid the product getting compacted inside the tank.**

The products to be used with the duster have physical characteristics that can be strongly modified by the temperature and humidity conditions at the moment of treatment. Therefore, it is not possible to obtain and set reliable delivery amounts corresponding to the various opening indexes of the delivery holes on the tank bottom.

Usually, the machine allows deliveries from a min. 0,4 up to max. 8 kg/min., with the opening index set on No. 5. To do a treatment with constant powder distribution, it is possible to set the on-of lever at the same opening position by the locking handle.

## 3.5 - HANDLING OF AGRO-CHEMICALS

The **operator** may be contaminated either by contact with or inhalation of the products and mixtures to be distributed.

The **environment** may be polluted by the spillage of the products, the careless conservation of empty or unwashed packages, and by pouring the products into the water system.

To avoid these risks, the filling operations should be carried out in suitably prepared and adequately equipped areas, or on the treatment site.

### 3.5.1 - Storage

**Fixed / stationary:** the site used must be well ventilated and secured by lockable doors in order to prevent even accidental access by children or unauthorised persons.

**Mobile:** the carrier equipment must be properly locked and kept under conditions whereby access by children or unauthorised persons can be prevented during the absence of the operator. All full or partially utilised containers must be secured against tipping, falling or breakage during transportation. Both types of storage must:

- have a suitable container for the storing of empty packaging materials should a specific storage area not be available;
- have a clean water supply readily available for washing, by means of a specific container or through connection to the waterworks system;
- have the use of fire extinguishers, should flammable products and substances be stored.



- **All packages, whether whole or partially utilised, must be stored in their original packing and with the warning instructions clearly displayed and legible.**
- **The storage indications must always be scrupulously adhered to, as well as their utilisation and possible disposal as suggested on the product's original packaging.**

### 3.5.2 - Specific equipment

The site at which the preparation and filling out will take place must provide for:

- all the equipment necessary to the precise measuring of both the dose of product to be mixed in the tank at every filling;
- all the equipment and means useful to the preparation of the mixture and for the cleaning of the operator in case of contamination;
- all tools necessary to facilitate the direct introduction of the agro-chemicals in the tank;
- the allocation of clothing and specific equipment in order to avoid contamination by contact or inhalation during the whole operative phase of the intervention.

### 3.5.3 - Disposal of empty containers and agro-chemicals residues

Agro-chemicals are classified as "special" waste and their disposal must take place separately from "urban" wastes.



**Empty packaging and contaminated containers to be done away with cannot be dispersed, burned or buried.**

**The washing water for the cisterns and the tools utilised for the preparation of mixtures cannot be emptied on the ground, spilled into the sewage system or in waterways and rivers.**

The disposal of special wastes is regulated by specific norms. In order to perform this operation it is necessary to obtain the relevant information from the Local Offices specifically appointed to rule on this subject. The non compliance with these regulations can cause considerable damage to persons and animals as well as polluting the environment.

### 3.5.4 - Personal means of protection

The toxicity of agro-chemicals forces persons working with them to wear adequate protective clothing and accessories in order to avoid risks of contamination by contact or inhalation.



In each of the following work stages:

- filling of tanks and adding of the agro-chemical,
  - dusting,
  - adjusting of the duster,
  - emptying and cleaning of the tank,
  - replacement of the agro-chemical,
  - maintenance interventions,
- it is necessary to wear personal protection clothing and accessories.

The following must be worn:

- Polyethylene or polyvinyl gloves.
- Full, waterproof cotton overalls, in order to guarantee transpiration, fitted with polypropylene side flaps.  
In commerce, one-time 'tyvek' overalls are available which, after use (see picture), must be disposed of according to the modalities applicable to toxic waste.
- A protective half-mask in polychloroprene rubber with 1 or 2 filters. Filters for gases and organic fumes, of European A1-class vapours, are envisaged and these can be combined with anti-dust models of P1 European class, for harmful mists and powders, or P2, for harmful and toxic mists and powders.

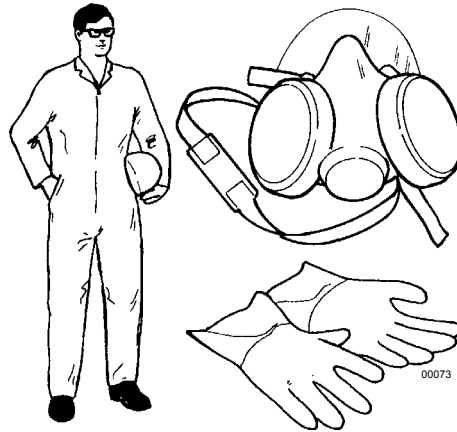

The filters must be replaced:

- when the smell/taste of agro-chemicals can be detected, and that of active A1-class carbons;
- when difficulty in breathing is experienced for the anti-dust filters of class P1 and P2.

In any case it is necessary to make use of all personal means of protection as suggested by the manufacturers.



### 7.1 - PAIR OF WHEELS

The wheels thread can be adapted to that of the tractor.



**MOUNT THE WHEELS AFTER HAVING HITCHED THE DUSTER TO THE THREE-POINT LINKAGE. DISMANTLE THE WHEELS BEFORE UNHITCHING THE DUSTER FROM THE THREE-POINT LINKAGE.**

#### EXECUTION:

1. Hitch the machine to the tractor and lift it to a height at which the wheels can be mounted.
2.   Stop the tractor, remove the key from the control panel and ensure that no one operates the three-point linkage's hydraulic controls. **AVOID OPERATING AND STANDING BENEATH THE MACHINE OR WITHIN THE AREA THAT MIGHT BE INVOLVED IN ITS SUDDEN LOWERING.**
3. Insert the wheels' axle shafts into the machine's axle.
4. Adapt the wheels' track to that of the tractor.
5. Lock the axle shafts by means of the axle screws.
6. Start the tractor and keep the duster lifted during the transfers, lowering it to carry out the treatment.



**THE DUSTER MUST BE LIFTED AT EVERY DIRECTION CHANGE MAKING SURE THAT THE WHEELS ARE NOT RESTING ON THE GROUND.**

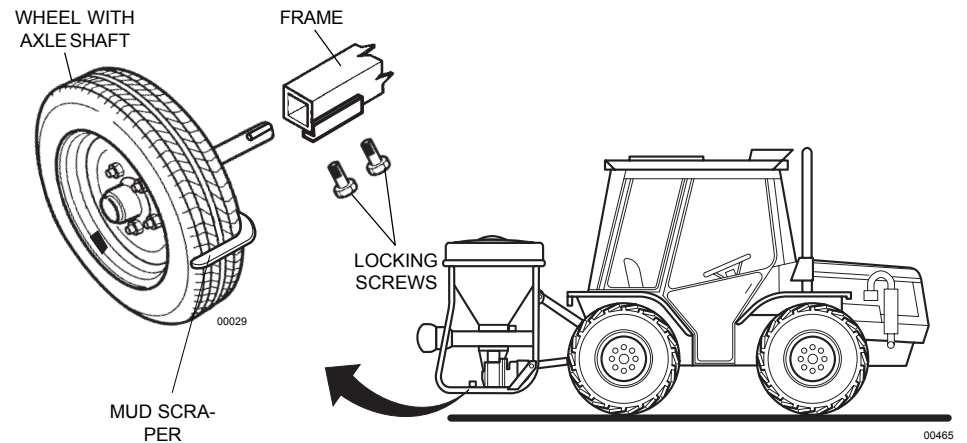

Wheel dimension .....	135/80 - 13
Wheel pressure .....	3,3 atm
Wheel weight, with axles .....	40 kg



**ESSE 520 - ESSE 530**

- 1- 2 SWINGING FISHTAILS SPRAYHEAD ..... I.2V.S5.0 ..... weight kg 6
- 2 - 2 SWINGING FISHTAILS SPRAYHEAD with right or left closing ... I.2V.CH.S5.01 ..... weight kg 7
- 3 - 2 SWINGING FISHTAILS SPRAYHEAD with extension ..... I.2V.L.S5.01 ..... weight kg 9
- 4 - 2 SWINGING FISHTAILS SPRAYHEAD with extension  
and right or left closing ..... I.2V.LCH.S5.01 . weight kg 10
- 5 - SWINGING CANNON JET ..... I.GCO.S.01 ..... weight kg 2,5
- 6 - SWINGING CANNON JET with additional fishtail. .... I.GC2.S.01 ..... weight kg 5,5
- 7 - 2 LITTLE CANNONS SPRAYHEAD ..... I.2C.S5.01 ..... weight kg 6,5
- 8 - 4m AIR BOOM 4 outlets ..... I.BR.S5.44.01 .... weight kg 63
- 6m AIR BOOM 5 outlets ..... I.BR.S5.65.01 .... weight kg 66
- 6m AIR BOOM 6 outlets ..... I.BR.S5.66.01 .... weight kg 69
- 8m AIR BOOM 8 outlets ..... I.BR.S5.88.01 .... weight kg 81

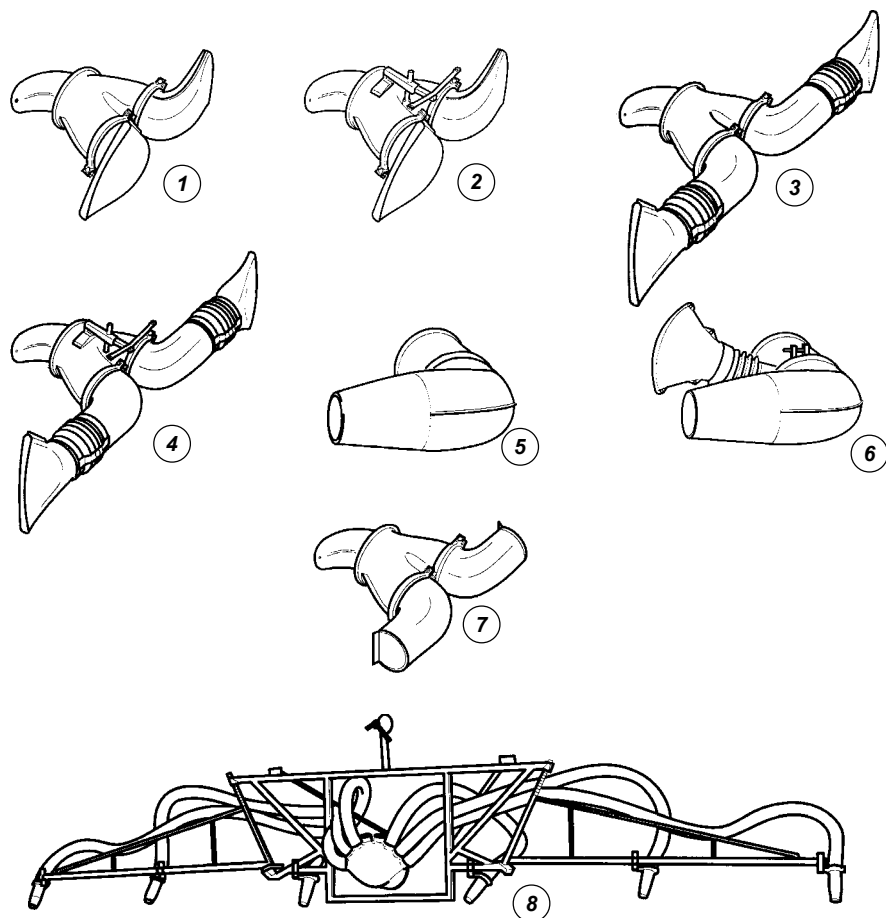

**4 MACHINE'S STRUCTURAL ANALYSIS 4**

The pictures indicate the position of the main components of the duster.

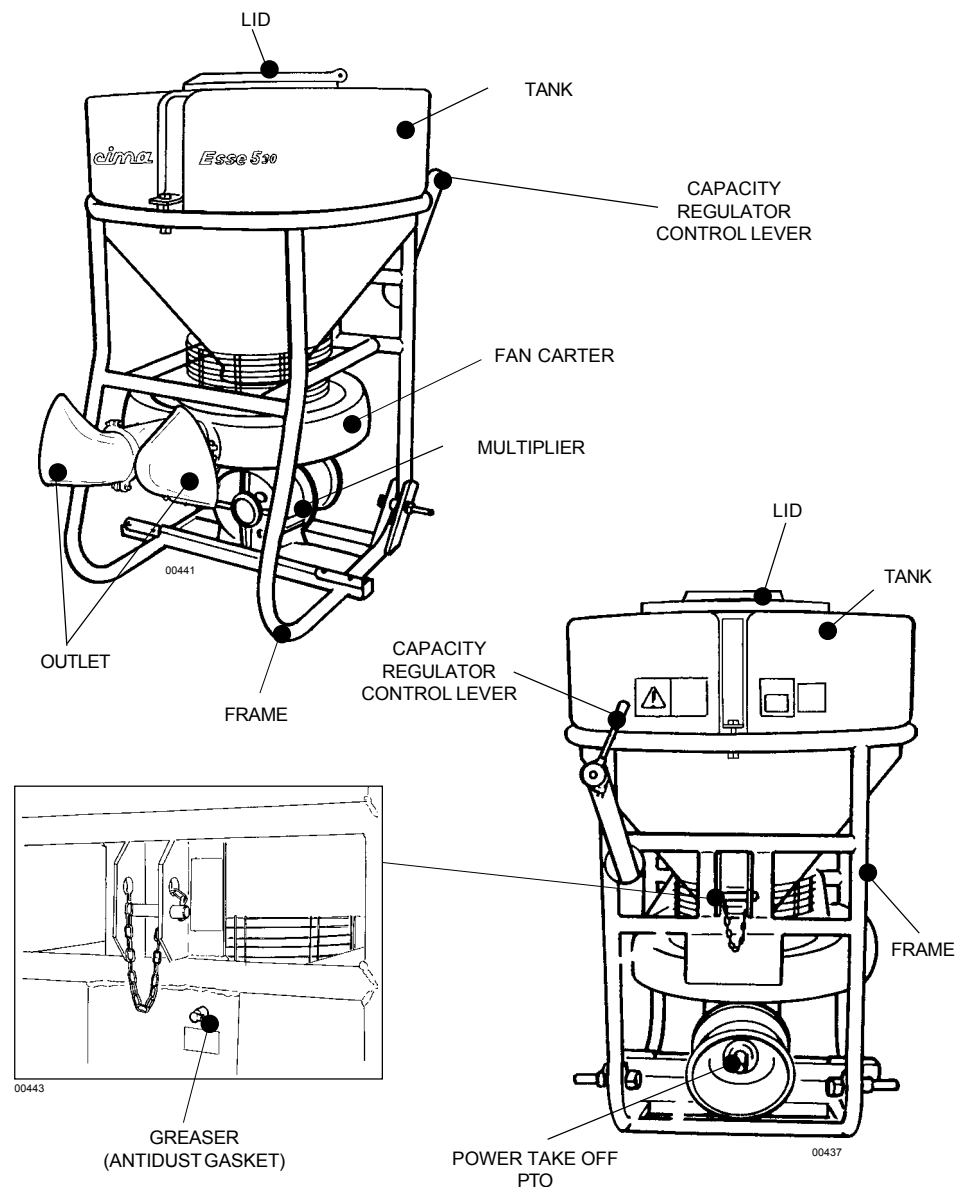

### 4.1 FRAME

The frame may be coupled to hydraulic hoists of class "1". The diameter of the gudgeon is 22mm. The pin of the third point is 19mm. in diameter.

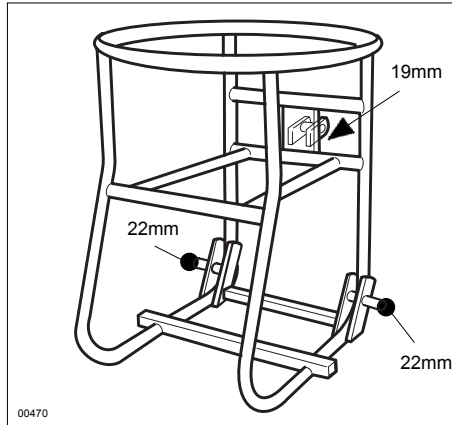

### 4.2 - MULTIPLIER

- Aluminum gearbox. On the side opposite the PdP. It has a sight plug for filling and checking the oil level; at the center there is another service plug to make interventions on the conical couple easier; underneath discharge plug.
- Conical Couple with high-tensile steel helicoidal teeth, dimensioned with a wide safety margin that works in oil bath.
- PdP protection casing attached on the multiplier cover.

**The multiplier should work with PdP at 540 RPM. For a good result of the treatments this condition MUST ALWAYS BE OBSERVED during the machine's operation. Utilisation is permitted with speed rates ranging between 500 and 620 RPM.**

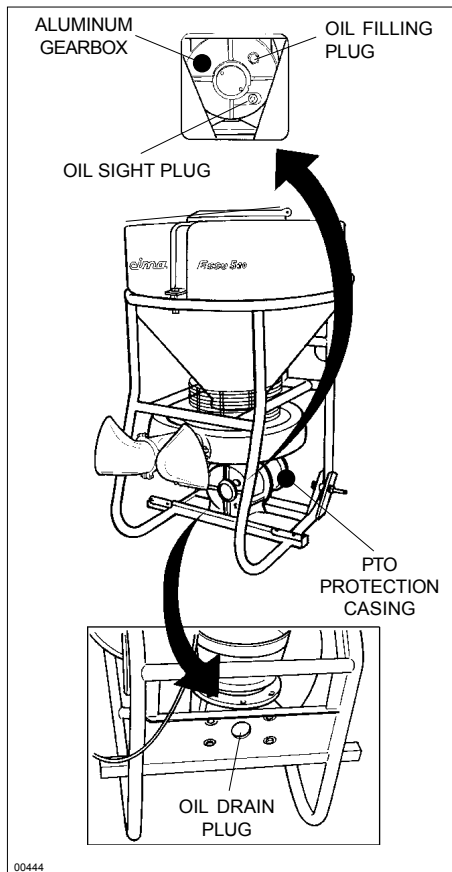

### 5.3 - INSTALLATION OF CAPACITY REGULATOR CONTROL LEVER

EXECUTION:

1. Mount the securing bracket on the tractor within the driver's reach.
- 2 - Insert the control lever's bayonet support in the securing bracket.

**Position the regulation lock connection flexible cable in such a way to avoid that, during the treatment, it can get torn. If necessary, use some fastening belts.**

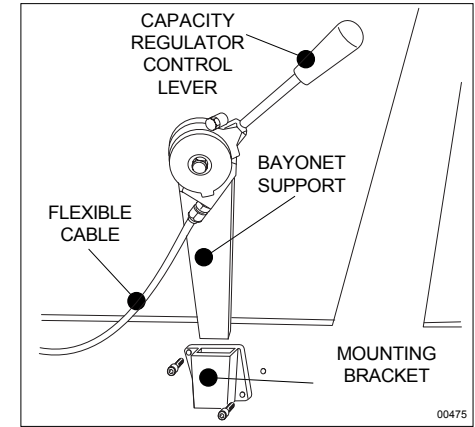

## 6 DISTRIBUTION DEVICES 6

**All the heads CAN BE ORIENTED. The regulation of the position allows to optimise the distribution, according with the ground and with the type of culture to be treated.**

### ESSE 420 - ESSE 430

- 1 - 2 SWINGING FISHTAILS SPRAYHEAD ..... I.2V.S4.01 ..... weight kg 6
- 2 - 2 SWINGING FISHTAILS SPRAYHEAD with right or left closing ... I.2V.CH.S4.01 ..... weight kg 8
- 3 - SWINGING CANNON JET ..... I.GCO.S.01 ..... weight kg 2,5
- 4 - SWINGING CANNON JET with additional fishtail. .... I.GC2.S.01 ..... weight kg 5,5
- 5 - 2 LITTLE CANNONS SPRAYHEAD ..... I.2C.S4.01 ..... weight kg 6,5

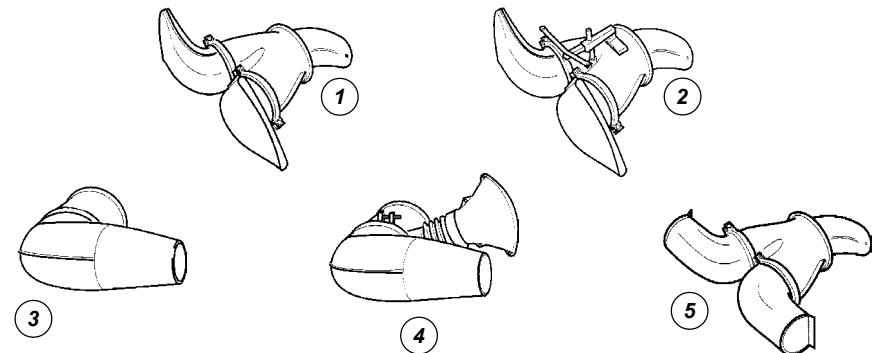

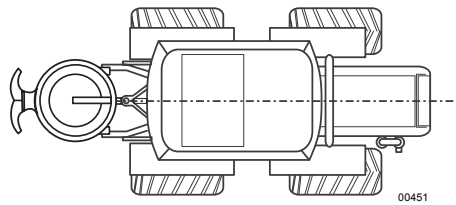
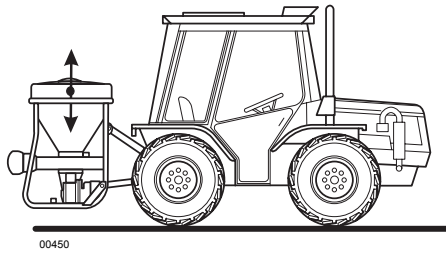

## 5.2 - MOUNTING OF THE TRANSMISSION SHAFT



USE CARDAN TRANSMISSION SHAFTS WITH CE CERTIFICATION. OBSERVE THE REGULATIONS CONTAINED IN THE USE AND MAINTENANCE BOOK-LET PROVIDED BY THE SHAFT MANUFACTURER.



The cardan transmission shaft must work with the 2 COAXIAL drive outlets (PTO) or, should this not be possible, with the PARALLEL axles. In this case the angle of the joint MUST NOT EXCEED 15°.

### Definition of the length

Set the 2 drive outlets (PTO) perfectly on the same axis and measure the distance "D" between their grooves.

Length "L" of the cardan transmission shaft (refer to the picture) to be deployed, measured between the 2 stopping pawls and with cardan shaft closed, must be 25 mm lesser than distance "D".

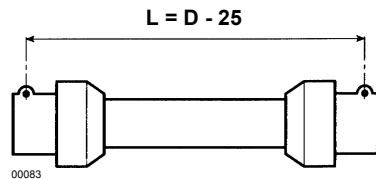
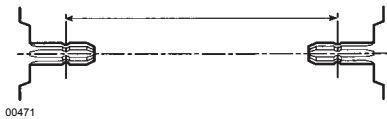
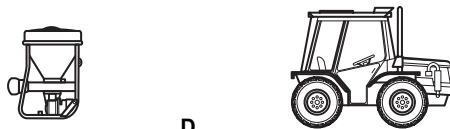
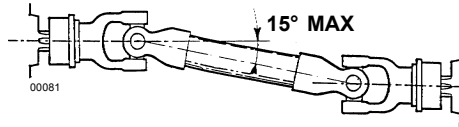

The mounting, disassembling or possible other interventions on the cardan transmission shaft must be carried out with the engine switched off and with the starter key removed from the tractor's control panel.

## 4.3 - FAN

- Aluminum **carter** with rear outlet.
- Centrifuge **fan** enclosed in steel, balanced dynamically.

## 4.4 - TANK BOTTOM

- It is made of aluminum and has 4 holes to let the powder fall. A distributing mixer controlled by the multiplier rotates. Underneath it, there is a register with 4 holes which allows the adjustment of the powder distribution.
- Between the lid with bush, which attaches the register to the bottom, and the pinion driving the mixer, is a felt seal against powders. Its functionality is guaranteed by a greaser inserted on the lid.

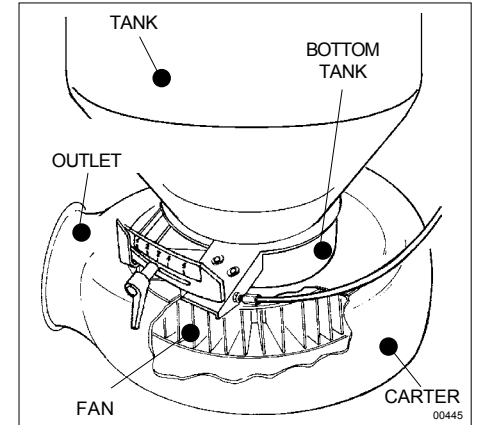

## 4.5 - TANK

- Realized in polyethylene, the tank is fastened to the machine frame and provided with an overturning plastic cover.



Before opening the lid, stop the tractor and take the key out of the control panel.



Check that the lid is closed before starting the tractor again.

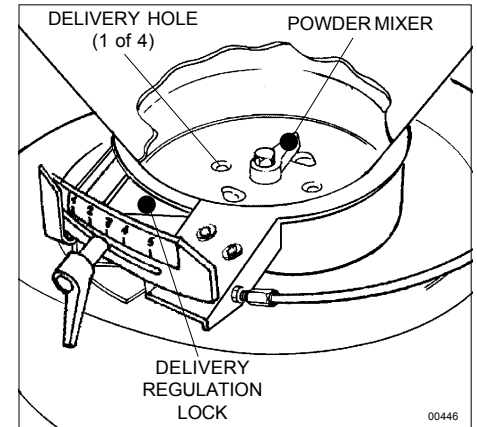

## 4.6 - CAPACITY REGULATOR

The control lever, which is fastened to the bayonet support through which it can be fastened on the tractor, at operator's reach, is connected to the regulation lock appendix through the actuation flexible cable.

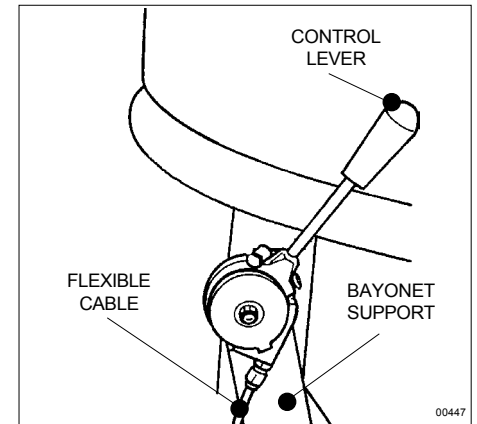

The small square-type indicator slides on a graduated scale from 0 to 5, of the bayonet support of the remote control. It shows the width of the opening of the distribution holes. "0" means full closure, "5" maximum delivery. The handle locks the small square that keeps the opening of the control lever in the desired position.

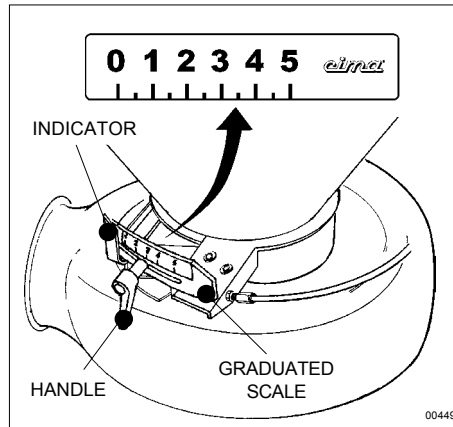

#### 4.7 - TECHNICAL DATA

	ESSE SERIES			
	420	430	520	530
<b>DIMENSIONS AND WEIGHTS (without head)</b>				
Lenght (mm)	1225	1225	1235	1235
Total width (mm)	935	935	935	935
Total height (mm)	1175	1325	1440	1590
Weight, empty (kg)	103	105	136	138
Weight, full-load (kg)	233	305	266	338
<b>TECHNICAL SPECIFICATIONS</b>				
Tank capacities (litres)	200	300	200	300
Tank capacities, with sulphur (kg)	~150	~200	~150	~200
Multiplication ratio	1:5,8		1:5,18	
PTO shaft	1 3/8" SAE DIN 9611/A			
Multiplier oil - SAE 90 (kg)	1			
Rear outlet diameter (mm)	175			
Fan diameter (mm)	400		500	
Fan speed (RPM)	3130		2800	
Air flow rate (m³/h)	2100		3470	
Air speed (m/sec.)	90			
PTO power absorbed (CV-kW)	8 - 5,9		12 - 8,8	

The duster's weight indicated in the table doesn't include the weight of the cardan shaft nor that of the head applied to the machine. The weight of the single distribution heads is indicated in the following Chapter 6. As far as the weight of the cardan shaft is concerned, reference shall be made to the relevant specific documentation.

#### 5.1 - HITCHING TO THE TRACTOR

Check that the tractor's "permissible carried weight" and the "rear overhang allowed" are compatible with the weight and dimensions of the fully loaded duster and complete with equipment mounted for the treatment (see Paragraphs "3.1" - "4.7" and "6").

The tractor's power take-off (PTO), under all utilisation conditions, must provide a power exceeding that absorbed by the duster.  
**COUPLING POWER WITH TRACTORS OF AT LEAST:**  
 18 CV = 13,2 KW for dusters ESSE 420 e ESSE 430  
 25 CV = 18,4 KW for dusters ESSE 520 e ESSE 530

For the models ESSE 520 and ESSE 530, the coupling to the tractor SHALL be realized by using a cardan transmission shaft equipped with a clutch.

The duster should be mounted on a flat surface, taking care to clear away all people not involved in the operation, including children and animals.

##### EXECUTION:

- Loosen the chains of the lifter arms.
- Start the tractor and take the lifter's arms to the level of the machine's pins.
- Stop the tractor and remove the key from the control panel.**
- Insert the toggle joints on the machine's pegs, locking them with the clip pins.
- Take the tension rod off of the tractor's 3rd point and locking it with the release pin.
- Screw the tension rod slightly to put it in tension.
- Start the tractor and hoist the duster until the 2 PTO are the same height.
- Stop the tractor, remove the key from the control panel and make sure that no one approaches the hydraulic controls of the lifter. NEVER OPERATE OR STAND BENEATH THE MACHINE OR IN THE AREA THAT COULD BE INVOLVED IN ITS SUDDEN LOWERING.**
- By acting on the 3<sup>rd</sup>-point rod, vertically align the duster. **N.B.:** block the 3<sup>rd</sup>-point rod with the specific lock ring.
- Block the coupling by tightening the chains of the hoister arms.

When the operation is completed the 2 drive outlets (PTO) must be positioned on the same axis, both in vertical and horizontal direction.