



**S420 - S430** €  
**S520 - S530** €

## OPERATION AND MAINTENANCE INSTRUCTIONS

**cima**® S.p.A.

27040 Montù Beccaria - Loc. Molino Quaroni - (PV) - ITALIA  
Tel. +39.0385.246636 r.a. - Fax +39.0385.246637

<http://www.cima.it>

**cima**®

**atomizzatori e impolveratori**

Dear Customer, thank you very much!

We want to congratulate with you, for having chosen a **cima**® Xi ghYf.

Your choice shows the wisdom of the well-informed Purchaser, aware of the fact, that the required features of quality, technique and reliability must be satisfied at the right price!

Our continuous engagement in R&D and in testing our machines allows us to realize products able to offer the best performances, a high reliability and a great easiness of use at the same time !

Our first goal, is to get our Customers happy for having met us!

The "Spare parts catalogue" of this duster is available in the "owners area" on website [www.cima.it](http://www.cima.it).  
In order to accede, use:

User name: **duster**  
Password: **546236NQ**

# Where we are





<b>DICHIARAZIONE DI CONFORMITÀ</b> ai sensi della direttiva CEE 89/392 e successive modificazioni		<b>CE</b>	
<b>DECLARATION OF CONFORMITY</b> as per EEC directive: CEE 89/392 and subsequent modifications	<b>CE</b>	<b>DECLARATION DE CONFORMITE</b> selon la directive 89/392/CEE et modifications ultérieures	<b>CE</b>
<b>ÜBERREINSTIMMUNGS-ERKLÄRUNG</b> lt. Direktiven der EWG 89/392 und nachfolgenden Änderung	<b>CE</b>	<b>DECLARACION DE CONFORMIDAD</b> con arreglo a la Directiva CEE 89/392 y modificaciones siguientes	<b>CE</b>
<b>CIMA s.p.a.</b>			
DICHIARA SOTTO LA PROPRIA RESPONSABILITÀ CHE LA MACCHINA:	HEREWITH DECLARES, UNDER THEIR PERSONAL RESPONSIBILITY THAT THE FOLLOWING MACHINE:	DECLARONS SOUS NOTRE RESPONSABILITE QUE LA MACHINE DECRITE CI-APRES:	BESTÄTIGT HIERMIT UNTER IHREIN PERSÖNLICHEN VERANTWORTUNG, DASS DIE MASCHINE:
DECLARA BAJO LA PROPIA RESPONSABILIDA QUE LA MAQUINA:			
SERIE, TIPO - MODEL, TYPE - SERIE, TYPE - MODEL, TYPE - SERIE, TIPO:			
<input style="width: 100%; height: 20px;" type="text"/>			
MATRICOLA - SERIAL - MATRICULE - SERIAL - MATRICULA NR.:			
<input style="width: 100%; height: 20px;" type="text"/>			
È conforme ai Requisiti essenziali di Sicurezza e di Tutela della Salute di cui alla Direttiva CEE 89/392 e sue successive modificazioni. Per la verifica della Conformità di cui alle Direttive sopra menzionate, sono state consultate le seguenti: Norme armonizzate EN: EN 294 EN 349.			
Conforms to the essential Safety regulation as well as the Health requirements as per European Economic Commu- nity Directive: CEE 89/392 and subsequent modifications. For the verification of conformity as per above mentioned directives the following official EN norms have been con- sulted: Harmonized EN norms: EN 294 EN 349.	Est conforme aux exigences de Sécurité et de Sauvegarde de la Santé dont à la Directive 89/392/CEE et modification ultérieures. Pour vérifier la conformité aux directives susmentionnées, ont été prises en compte les normes suivantes: Normes harmonisées: EN 294 EN 349.		
Stimmt mit den wesentlichen Requisiten der Sicher- heitsvorschriften und der Gesundheitsvorsorge lt. EWG Dire- ktive Nr. 89/392 und nachfolgenden Änderungsüberein- für die Überprüfung dieser Übereinstimmungs-Erklärung lt. obigen Direktiven sind folgende Normen konsultiert worden: EN Normen: EN 294 EN 349	Cumple con los requisitos esenciales de Seguridad y de Preservación de la Salud contenidos en la Directiva CEE 89/392 y modificaciones siguientes. Para comprobar la conformidad a la que se refieren las Directivas anteriormente citadas, se han consultado las siguientes: Normas Armonizadas EN: EN 294 EN 349		
Responsabile della Sicurezza - The Security Official - Responsable Sécurité et Homologations - Der Sicherheits-Beamter - Responsable de la Seguridad			
Data, Date, Date, Datum, Fecha, _____			

3-POINT MOUNTED DUSTER

**S 420 - S430**  
**S 520 - S530**

Serial No.: .....

**OPERATION AND MAINTENANCE  
 INSTRUCTIONS**



27040 MONTU' BECCARIA - PV - ITALIA  
 Loc. Molino Quaroni - Tel. 0385/246636 r.a. - Fax 0385/246637

**LIST OF VALID PAGES**

This publication is composed of 27 pages divided in the following manner:

PAGE NO.	REVISION	ISSUE DATE
from I to IV	01	Dicember 2001
from 1 to 23	01	Dicember 2001

**REGISTRATIONS OF ADDITIONS AND CHANGES**

REVISION	DESCRIPTION
00	First Edition, March 1996
01	General revision, Dicember 2001
02	
03	
04	
05	
06	
07	
08	



THE OPERATOR IS NOT ALLOWED TO CARRY OUT MODIFICATIONS ON THE DUSTER STRUCTURES OR ON ITS OPERATION. THIS WOULD MEAN THE IMMEDIATE LOSS OF THE EXISTING RIGHTS OF WARRANTY AND WOULD FREE CIMA S.p.A. OF ANY CONSEQUENT RESPONSABILITY.

The machines are guaranteed for **12 months** from the date of delivery. During this time, the parts that are not normally subject to wear and that are found defective will be replaced free of charge, except for transport and workmanship costs.

The warranty is no longer valid when:

- a. The machine is repaired without the permission of the manufacturer or one of its assistance centers.
- b. Non-original spare parts are used.
- c. The machine is used for purposes different from its original intended use.
- d. The instructions contained in this manual and in the accompanying integrating parts have not been complied with.

14 **DIAGRAM OF THE DUSTER** 14

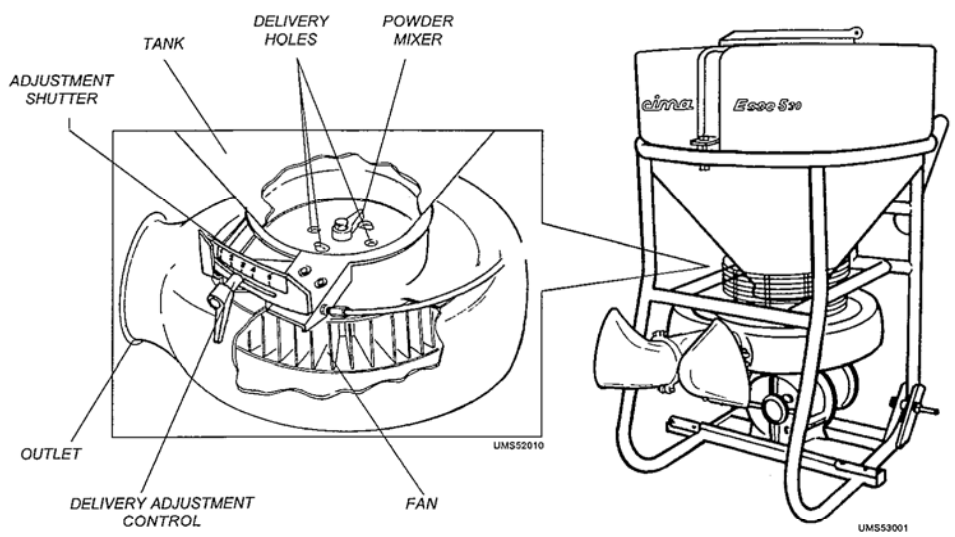

**TABLE OF CONTENTS**

- 1 INTRODUCTION** ..... 1
  - 1.1 IDENTIFICATION OF THE PUBLICATION ..... 1
  - 1.2 PUBLICATIONS ATTACHED ..... 1
  - 1.3 PURPOSE OF THE PUBLICATION ..... 1
  - 1.4 REGULATION REFERENCES ..... 1
  - 1.5 USE OF THE MANUAL ..... 1
  - 1.6 UPDATES ..... 2
- 2 GLOSSARY** ..... 2
  - 2.1 TERMINOLOGY ..... 2
  - 2.2 ABBREVIATIONS ..... 3
  - 2.3 SAFETY DECALS - USE AND MAINTENANCE ..... 3
- 3 GENERAL INFORMATIONS** ..... 5
  - 3.1 IDENTIFICATION OF THE MACHINE ..... 5
  - 3.2 TECHNICAL ASSISTANCE ..... 5
  - 3.3 SAFETY WARNINGS ..... 5
  - 3.4 SAFETY DEVICES ..... 6
  - 3.5 HANDLING OF PHYTOPHARMACEUTICALS ..... 7
    - 3.5.1 Storage ..... 7
    - 3.5.2 Specific equipment ..... 7
    - 3.5.3 Disposal of empty packages and phytopharmaceutical residue ..... 7
    - 3.5.4 Personal protection means ..... 8
- 4 STRUCTURAL ANALYSIS OF THE MACHINE** ..... 9
  - 4.1 TANK ..... 10
  - 4.2 TANK BOTTOM ..... 10
  - 4.3 FAN ..... 10
  - 4.4 MULTIPLIER ..... 10
  - 4.5 CAPACITY REGULATOR ..... 10
  - 4.6 FRAME ..... 10
  - 4.7 TECHNICAL DATA ..... 11
- 5 COUPLING MODE** ..... 11
  - 5.1 TRACTOR HOOK-UP ..... 11
  - 5.2 DRIVE JOINT ASSEMBLY ..... 12
- 6 DISTRIBUTION DEVICES** ..... 13
- 7 LOADING PROCEDURES** ..... 15
  - 7.1 WITH A NEW DUSTER OR AT THE BEGINNING OF EACH TREATMENT ..... 15
  - 7.2 DURING TREATMENT ..... 15
- 8 CONSTANT DELIVERY CONTROL** ..... 16
- 9 PROCEDURES FOR USE** ..... 16
  - 9.1 OPERATIONS PRIOR TO TREATMENT ..... 16
  - 9.2 OPERATIONS IN PREPARATION FOR TREATMENT ..... 17
  - 9.3 TREATMENT ..... 17
  - 9.4 END OF TREATMENT - STORAGE ..... 18

9.4.1	Daily .....	18
9.4.2	End of Seasonal Cycle .....	18
10	LIFTING AND TRANSPORT .....	18
11	MAINTENANCE OPERATIONS .....	19
11.1	GREASING .....	20
11.2	LUBRICATION .....	20
12	TROUBLE SHOOTING .....	21
13	REPAIRS ALLOWED .....	21
14	DIAGRAM OF THE DUSTER .....	22
15	WARRANTY .....	23

**A. PROBLEM: Oil leakage from the cover of the multiplier box**

1. CAUSE: The cover seal is defective.  
*REMEDY: Refer to CIMA after sale service.*
2. CAUSE: The sealing ring on the cover is defective.  
*REMEDY: Refer to CIMA after-sale service.*

**B. PROBLEM: Vibration of the ventilator group**

1. CAUSE: The fan is dirty or out of balance.  
*REMEDY: Refer to CIMA after-sale service.*
2. CAUSE: The PdPs are not aligned or are not parallel.  
*REMEDY: Position the PdPs in the correct way.*

**C. PROBLEM: Abnormal and constant noise with vibrations**

1. CAUSE: Breakage of the multiplier bearings.  
*REMEDY: Refer to CIMA after sale service.*

**D. PROBLEM: Non-delivery of powders**

1. CAUSE: The feeding holes on the tank bottom are clogged.  
*REMEDY: Clean them.*
2. CAUSE: Caking of the tank's contents.  
*REMEDY: Breake up the powder.*

**E. PROBLEM: Distribution on the two sides is not uniform**

1. CAUSE: The compensation plate of the head has moved.  
*REMEDY: Adjust it in order to get a uniform distribution.*



THE OPERATOR IS NOT ALLOWED TO CARRY OUT MODIFICATIONS ON THE DUSTER STRUCTURES OR ON ITS OPERATION. THIS WOULD MEAN THE IMMEDIATE LOSS OF THE EXISTING RIGHTS OF WARRANTY AND WOULD FREE CIMAS.p.A. OF ANY CONSEQUENT RESPONSABILITY.

ALL INTERVENTIONS THAT THE MACHINE MAY REQUIRE SHOULD BE CARRIED OUT BY A CIMA AFTER-SALE SERVICE CENTER.

### 11.1 - GREASING

At the beginning of the treatment season and after every 50 hours work, grease the felt seal with EP type NGL2 class grease.

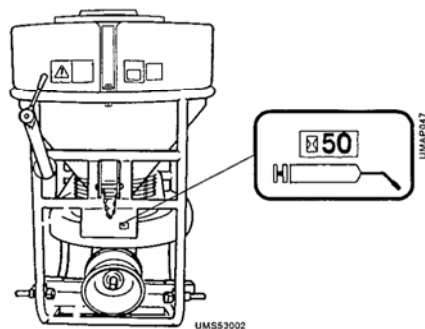

- Accurately clean the greaser before use: dirt could be introduced together with grease.
- In case of intensive use of the machine, increase the lubrication periods.

### 11.2 - LUBRICATION

When the machine is sitting on a flat surface, the oil level inside the multiplier should always be visible through the oil indicator situated on the guard cover.

It is not necessary to replace the oil in the multiplier, but it is essential to always keep it at the required level. The necessary fill-ups must be done through the filling plug by leaning the machine or laying it down.

Always use SAE 90 oil.



- At the beginning of the treatment season and before every intervention, check the oil level in the multiplier guard.

A plug situated under the multiplier box allows for the discharge of the oil.

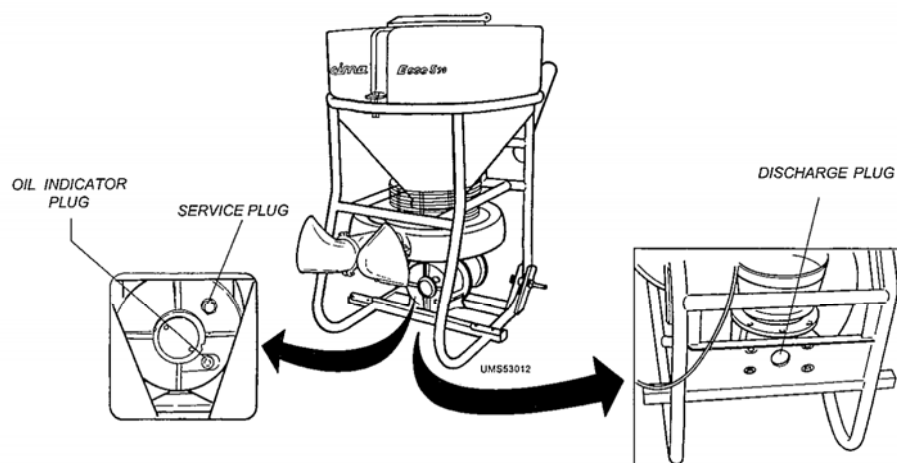

### 1.1 - IDENTIFICATION OF THE PUBLICATION

The manual "INSTRUCTIONS FOR USE AND MAINTENANCE" is an official document issued by C.I.M.A.S.p.A. and is considered an additional part of the duster. The manual displays a publication number on the third cover page which allows for identification, tracing and reference.

All of the information contained here has been accurately checked. C.I.M.A. S.p.A. reserves the right to modify this manual without prior notice and does not take responsibility for any errors and/or omissions.

### 1.2 - PUBLICATIONS ATTACHED

- Spare parts catalogue.

### 1.3 - PURPOSE OF THE PUBLICATION

All of the necessary indications for use and maintenance contained in this manual are meant for the utilization of the duster. The duration and functionality of the machine, the operator's safety and the respect of the environment all depend on the careful observance of the regulations described herein.

Before using the duster, the operator should read and respect all of the instructions listed in this manual, which are updated through the publication date.

### 1.4 - REGULATION REFERENCES

This manual was created in conformity with the instructions contained in:

- Enclosure "I" of instruction 89/392/C and subsequent modifications (letters "b", "c" of point 1.1.2 and point 1.7.4);
- UNI EN 292/2 - 1992, point 5.5.

### 1.5 - USE OF THE MANUAL

Read this manual from the beginning to the end without omitting any pages, paying special attention to the meaning of the warning or danger instructions in the text and shown by the signs displayed on the machine or on its parts. All of the operations described herein should be carried out with the utmost care and only after having understood the negative consequences of executing them poorly.

The manual is divided into two parts.

\* The first, whose pages are marked with Roman numerals, is formed by:

- Title page
- List of valid pages
- Registration of additions and changes
- Table of contents

This allows for the identification of the publication and awareness of its level of updating and validity regarding the product. The table of contents allows the user to find the pages concerning the subject he/she is interested in quickly and efficiently.

\* The second part, whose pages are marked with cardinal numbers, has been developed so as to give the user the necessary information for working while respecting the safety standards during all of the stages of preparation, use, handling and maintenance of the duster.

In the course of the text, we have used some symbols to highlight and visually distinguish the importance of the different kinds of information.

Graphic representation and meaning of the symbols:



Means important supplementary information.



The non-observance of the instruction given herein may cause damage to the duster which can be irreparable.



Indicates possible situations of danger for persons.

The manual, its enclosures and its possible integrations, should be kept with the utmost care and always be complete, integral and legible in all of its parts. In case of loss, the owner must immediately ask C.I.M.A. S.p.A. for a duplicate. If the decals originally placed on the machine should become lost, damaged or even partially incomprehensible, they must be replaced without delay.



- The manual should be kept for the entire life of the duster.
- All of the amendments received must be kept by inserting them in this publication.
- The manual should accompany the duster when it is sold.

## 1.6 - UPDATES

The possible updates that C.I.M.A. S.p.A. may send to the owner of the duster will be accompanied by the necessary instructions for inserting them in this publication.

If the machine is sold, the owner must ask the buyer to communicate his/her address to C.I.M.A. S.p.A., in order for them to send the possible integrations.

## 2.1 - TERMINOLOGY

This is to clarify some terms concerning the duster which are included in this publication.

FRONT PART: is where the duster is hitched to the tractor.

REAR PART: is where the distributing device is fitted.

RIGHT OR LEFT SIDE: correspond to the direction of the movement, or when looking at the machine from the side of the distributing device.

The "distributing device" can also be called "head".

- It is necessary to duplicate the license plate and the rear lights of the tractor if they are covered by the machine.

The operator must respect the laws for the use of the machine existing in the country where it is working. The operator will be held responsible for the non-observance of these laws.

## • Lifting and transport of the duster



Remove the head before lifting the duster.



All operations should be carried out with the tank completely empty.

1. Check that the cables or the chains are sufficient enough for the weight to be lifted.
2. Hook the machine in the supporting point indicated on the frame by the decal and check the tightening of all of the parts involved in the operation.

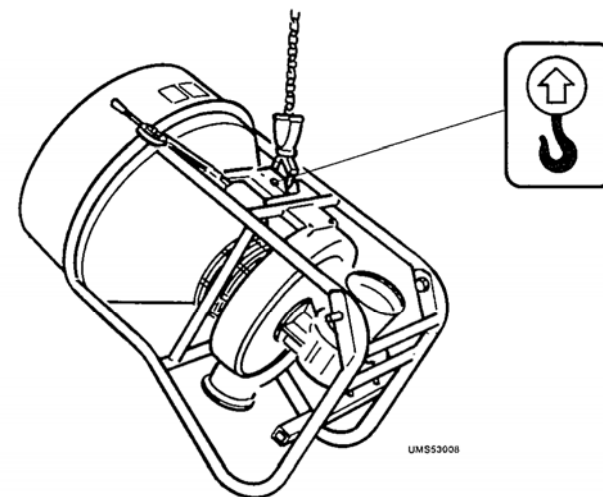

3. Lift the machine, placing it on the means of transport, which must be perfectly stable.
4. During the transport, the machine should be tied and fastened to the means of transport by an appropriate harness.



ALL THE OPERATIONS SHOULD BE CARRIED OUT WHEN THE MOTOR IS OFF AND THE IGNITION KEY IS OUT OF THE CONTROL PANEL.





The multiplier should work with the power take-off at 450 rpm. This limit must never be exceeded during the use of the machine.

- a. Use personal protection identical to that advised for the mixture, preparation and loading, if the tractor does not have a pressurized cab with aeration filters.
- b. Immediately wash all elements contaminated during the treatment, promptly take off the contaminated protection clothes and discontinue the job if these cannot be replaced.
- c. If the wind increases, follow the instructions given in the preliminary operations.
- d. During the pauses, stop the motor, take the key out of the control panel of the tractor and lower the hoist.
- e. Pay special attention when doing treatments near property lines, houses, waterways, roads or public paths.

## 9.4 - END OF TREATMENT - STORAGE

### THE OPERATOR MUST:

#### 9.4.1 - Daily

- a. Put the machine in a ventilated place, sheltered from the rain and the sun: the rays of the sun are the worst enemies of plastic and rubber parts.

#### 9.4.2 - End of Seasonal Cycle

- a. Carry out an accurate cleaning of the duster, emptying the tank and the distribution holes of any product residue. The operation must be done without the use of water or liquid detergents.
- b. Check to see if the machine's parts and structures are working correctly. In the case of negative results, ask for the intervention of one of our technical assistance centers.
- c. Put the machine in a ventilated place, sheltered from rain, ice and rays of sun.

10

## LIFTING AND TRANSPORT

10



### IT IS NOT PERMITTED:

- To transport and lift the duster with product residue in the tank for purposes different from its original use.
- To transport people, animals or objects.
- To tow vehicles or equipment.



Transport on the road should be done respecting the laws of the traffic code valid in the country where the machine is used.

- When the encumbrance of the duster is larger than that of the tractor, it is necessary to display the appropriate "wide load" sign on the back of the machine.

## 2.2 - ABBREVIATIONS

HP .....	horsepower
dB(A) .....	decibels
g/1' .....	revolutions per minute
kg .....	kilograms
km .....	kilometers
km/h .....	kilometers per hour
kW .....	kilowatts
L qA .....	equivalent sound level
lt .....	liters
m .....	meters
m <sup>3</sup> /h .....	cubic meters per hour
mm .....	millimeters
m/s .....	meters per second
PdP .....	power take-off
s .....	seconds

## 2.3 - SAFETY DECALS - USE AND MAINTENANCE

The machine is provided with decals concerning safety, use and maintenance..

### Safety

- 1 - 95001 - STOP THE MOTOR AND TAKE THE KEY OUT OF THE TRACTOR CONTROL PANEL BEFORE CARRYING OUT ANY MAINTENANCE OR REPAIR OPERATION.
  - Position: on the tank, front part of the machine.
- 2 - 95011 - DANGER: ROTATING COMPONENTS. BEFORE LIFTING THE LID, STOP THE TRACTOR, TAKE THE KEY OUT OF THE CONTROL PANEL AND MAKE SURE THAT ALL COMPONENTS HAVE STOPPED.
  - Position: on the tank, rear part of the machine.
- 3 - 95005 - DANGER: ROTATING COMPONENTS. BEFORE REMOVING THE PROTECTION DEVICES, STOP THE TRACTOR, TAKE THE KEY OUT OF THE CONTROL PANEL AND MAKE SURE THAT ALL COMPONENTS HAVE STOPPED.
  - Position: on the cone-like part of the tank, rear part of the machine.
- 4 - 95006 - ATTENTION: CONSULT THE USE AND MAINTENANCE MANUAL BEFORE USE OR WORK ON THE MACHINE.
  - Position: on the lid of the tank.
- 5 - 95010 - MAXIMUM WORKING SPEED OF THE POWER TAKE-OFF: 540 rpm.
  - Position: on the tank, front part of the machine.
- 6 - 95059 - HOOKING POINT FOR LIFTING THE MACHINE.
  - Position: front part of the machine: gudgeon for the third point of the hydraulic power-lift.

### Use and maintenance

- 7 - 95053 - GREASE EVERY 50 HOURS: FELT POWDER SEAL.
  - Position: left front part of the frame, under the third point.
- 8 - 95068 - ATTENTION: DISENGAGE THE CLUTCH GENTLY. FAN START-UP MUST BE GRADUAL.
  - Position: on the tank, front part of the machine.

THE 5-FIGURE NUMBERS ARE THE CODES TO BE USED FOR REQUESTING DECALS.

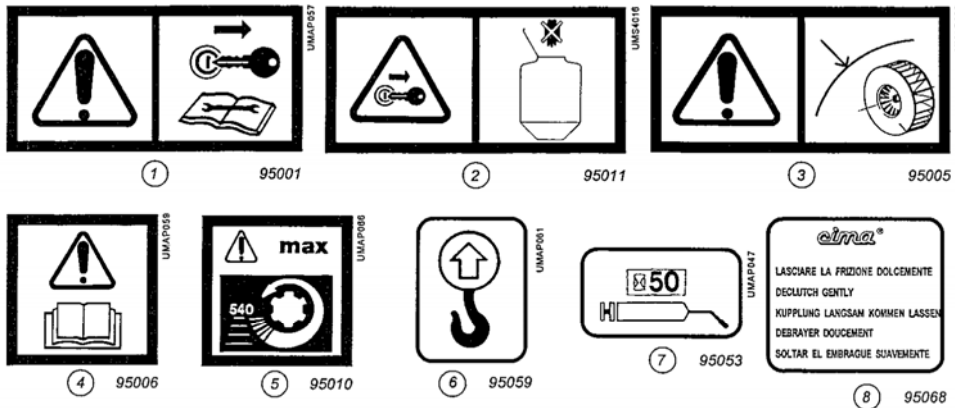
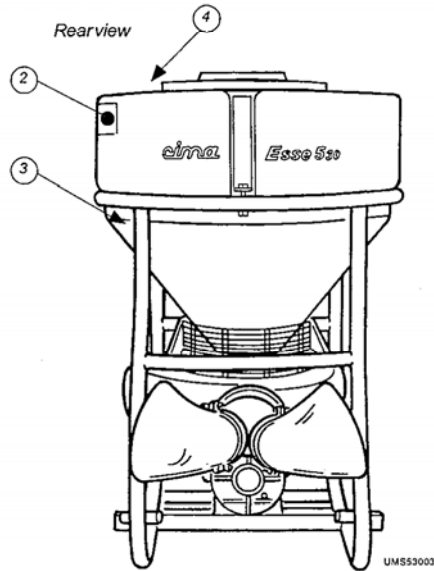
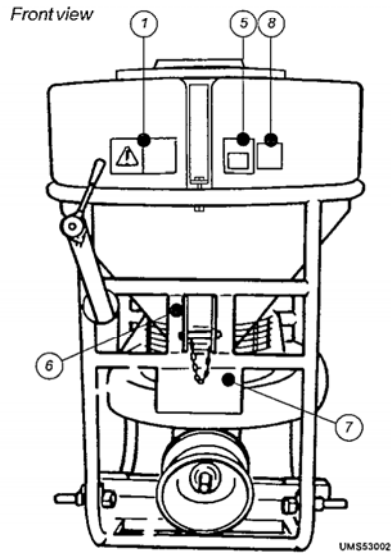

Positions of the safety, use and maintenance decals

## 9.2 - OPERATIONS IN PREPARATION FOR TREATMENT.

THE LOADING SHOULD BE DONE WITH THE MACHINE ON A FLAT SURFACE

THE OPERATOR MUST:

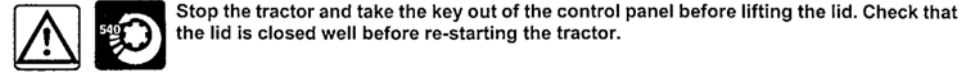

- a. Wear adequately protective clothes and accessories to avoid contamination either by inhalation or by contact with the products used, such as overalls, waterproof jacket, gloves, glasses and mask.

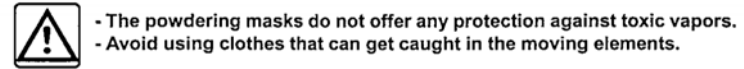

- b. Carry out all checking and maintenance operation necessary for setting up the machine.
- c. Perform loading in a well-ventilated place. If this is done outdoors, the presence of wind increases the danger of contamination.
- d. Avoid proximity of free flames, coals or burning objects with flammable products.
- e. Wash the emptied product packages with clean water and put them in the appropriate container or in the storage rooms.
- f. Wash the equipment and the tools used for preparation and keep them in the storage area for chemical products.
- g. Always leave the product loading and preparation area in conditions which will not cause any contamination to persons or animals, or environmental pollution.
- h. If necessary, mark the field or the machine passage area, to provide a guide for treatment and to avoid missing spots or overlapping layers.

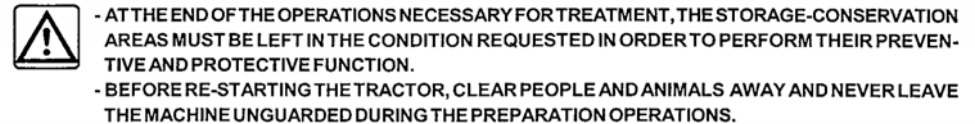

## 9.3 - TREATMENT

IT IS ADVISABLE TO BEGIN THE TREATMENT AT THE EDGE OF THE FIELD.

THE OPERATOR MUST:

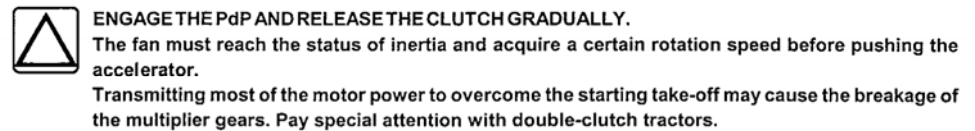

**8 CONSTANT DELIVERY CONTROL 8**

The products to be used with the duster have physical characteristics that can be strongly modified by the temperature and humidity conditions at the moment of treatment. Therefore, it is not possible to obtain and set reliable delivery amounts corresponding to the various opening indexes of the delivery holes on the tank bottom.

Usually, the machine allows deliveries from a min. 0,4 up to max. 8 kg/min., with the opening index set on No. 6. To do a treatment with constant powder distribution, it is possible to set the on-of lever at the same opening position by the locking handle.

**EXECUTION:**

1. Once the filling is completed, begin the treatment.
2. Using the on-off lever, find the delivery position suitable for the intervention.
3. Disengage the PdP without moving the on-of lever.



**Stop the tractor and take the key out of the control panel.**

4. Using the locking handle, release the square indicator-tab, bring it in contact with the adjustment lever and lock it again.
5. Re-start the treatment.

This operation ensures the equal opening of the delivery holes during the entire treatment.

**9 PROCEDURES FOR USE 9**

**9.1 - OPERATIONS PRIOR TO TREATMENT**

**THE OPERATOR MUST:**

- a. Make sure that the conditions of the cultivations, the disease stage, or the precautionary measures justify the treatment.
- b. Be aware of the weather-forecast for the period of time necessary for carrying out the treatment.
- c. If possible, avoid distributing in windy conditions or when the product begins drifting out of the cultivation. It is recommended to suspend treatment all together if the wind factor exceeds 3m/s (10 km/h).
- d. Calculate the exact amount of product needed for the treatment.
- e. Check that a sufficient amount of product for the whole treatment is available.
- f. Carefully read the instructions for the use of the product, check the conditions for use, the correct dosage and the expiration dates.

**3 GENERAL INFORMATIONS 3**

**3.1 - IDENTIFICATION OF THE MACHINE**



UMAP001

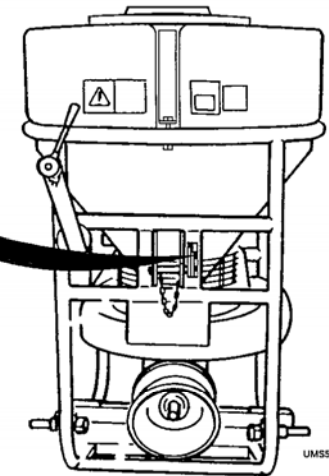

UMS53011

Identification nameplate

**3.2 - TECHNICAL ASSISTANCE**

C.I.M.A. S.p.A. is at its customers' full disposal for any kind of intervention. The names and addresses of its assistance centers, in Italy and abroad, may be requested at:

**C.I.M.A. S.p.A. - Loc. Molino Quaroni - 27040 MONTU' BECCARIA (PV) - ITALIA**  
**Tel.: 0385-246636 - Fax: 0385-246637**  
**from abroad: Tel.: 39-385-246636 - Fax: 39-385-246637**

**3.3 - SAFETY WARNINGS**

All of the preparation, use, maintenance, handling and transport operations should be carried out only after having acquired the perfect understanding of all instructions contained in this publication and the ability of interpreting the symbols applied on the machine in the correct way.



**IT IS NOT PERMITTED TO USE THE DUSTER FOR PURPOSES OTHER THAN ITS ORIGINAL USE, AS IT HAS BEEN DEVELOPED EXCLUSIVELY FOR DISTRIBUTING ANTI-MILDEW POWDERS ON AGRICULTURAL CULTIVATIONS.**

The following general rules must be respected scrupulously:



**STOP THE POWDER DELIVERY BEFORE DISENGAGING THE PdP WHEN THE FAN IS NOT RUNNING.**

- always stop the motor of the tractor before lifting the lid of the tank or carrying out any operation on the duster;
- check that the weight and power of the tractor are compatible with the duster to be used;
- before use, check the different components of the machine for correct tightness and fastening, paying special

attention to the safety protection devices and the running parts;

- use only transmission joints with protection devices, accompanied by EEC statement of conformity. Carry out the assembly only if the power take-off of the tractor and duster is equipped with a counter guard.
- check that the protection device of the transmission joint is fastened with the appropriate anti-rotation chains;
- clear people and animals away from the machine before starting it;
- do not wear clothes that can get caught in the running parts of the machine;
- reduce the speed when going over dips in the road or crossing ditches.



- All of the maintenance and repair operations should be carried out only after having carefully cleaned all the parts of the machine without water.
- It is forbidden to make weldings if ammonium salts have been used.
- It is forbidden to use the machine in a potentially explosive atmosphere.
- It is not permitted to spray paints and/or solvents, to wash areas and/or machinery or to utilize the air stream for purposes different from the distribution of phytopharmaceuticals.

### 3.4 - SAFETY DEVICES

All running parts of the machine are adequately protected and indicated with warning decals.



- It is forbidden to use the machine if the protection devices have been removed.
- Before lifting the tank lid or removing the protection devices, stop the motor of the tractor and take the key out of the control panel.
- Before beginning the distribution of the product, make sure that the lid is closed.

The picture shows the protected parts of the machine:

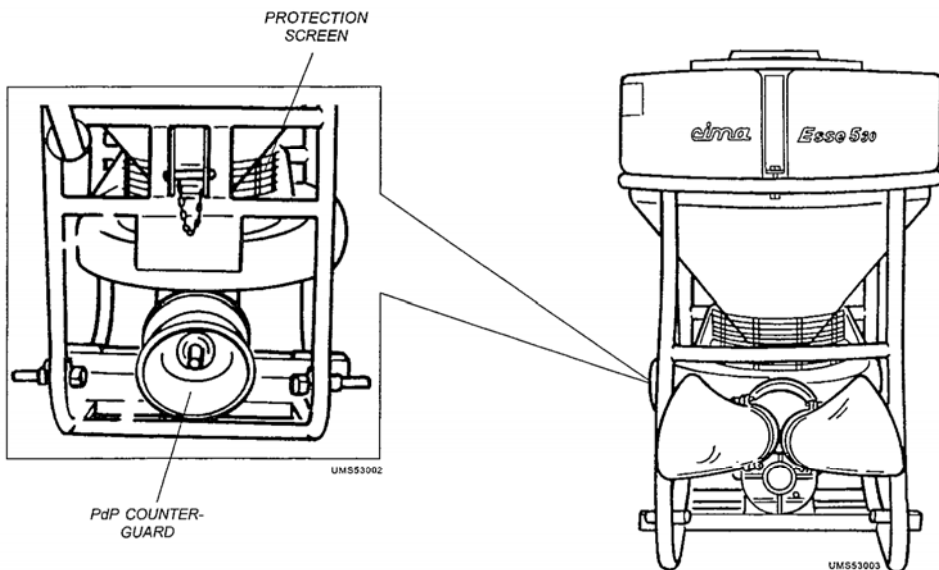

IT IS ALWAYS NECESSARY TO USE PERSONAL PROTECTION MEANS: OVERALLS, GLASSES AND MASKS.

### 7.1 - WITH A NEW DUSTER OR AT THE BEGINNING OF EACH TREATMENT

1. Before filling the tank, loosen the fastening handle on the adjustment. Bring the square indicator-tab to number 6 and block it again.
2. Bring the adjustment lever to "OFF".



Before lifting the lid of the tank, stop the tractor and take the key out of the control panel.

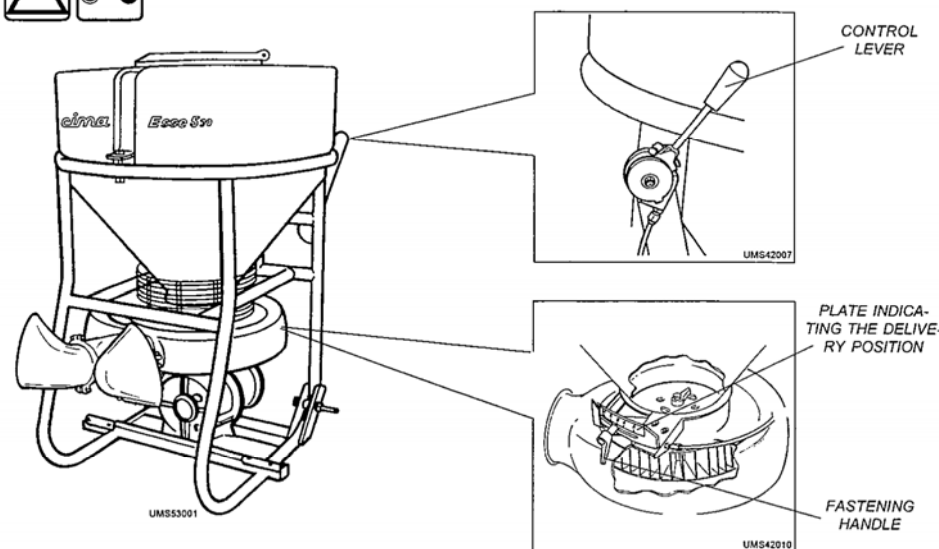

3. Fill the tank and close the lid.
4. Find the delivery suitable for the intended treatment and begin distribution.

### 7.2 - DURING TREATMENT



Before lifting the lid of the tank, stop the tractor and take the key out of the control panel.

1. Before filling the tank, stop delivery by bringing the control lever to the "0" position.
2. At the end of the operation, close the lid.



It is advisable to avoid travelling long distances when the tank is full.

**TYPES-IDENTIFICATION CODES-WEIGHTS  
FOR DUSTERS TYPE S 520-S 530**

1-TWO FISHTAILS.....	I.2V.S5.01.....	weight kg	6
2-TWO FISHTAILS WITH RIGHT OR LEFT CLOSURE.....	I.2V.CH.S5.01.....	weight kg	7
3-TWO FISHTAILS WITH EXTENSION.....	I.2V.L.S5.01.....	weight kg	9
4-TWO FISHTAILS WITH EXTENSION AND RIGHT OR LEFT CLOSURE.....	I.2V.LCH.S5.01.....	weight kg	10
5-SWINGING CANON.....	I.GCO.S.01.....	weight kg	2,5
6-SWINGING CANON.....	I.GC2.S.01.....	weight kg	5,5
7-HAZELNUTS.....	I.2C.S5.01.....	weight kg	6,5
8-PNEUMATIC BOOM 4m. (13 FT) 4 OUTLET.....	I.BR.S5.44.01.....	weight kg	63
PNEUMATIC BOOM 6m. (20 FT) 5 OUTLET.....	I.BR.S5.65.01.....	weight kg	66
PNEUMATIC BOOM 6m. (20 FT) 6 OUTLET.....	I.BR.S5.66.01.....	weight kg	69
PNEUMATIC BOOM 8m. (26 FT) 8 OUTLET.....	I.BR.S5.88.01.....	weight kg	81

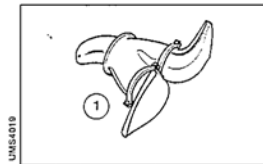

I.2V.S5.01

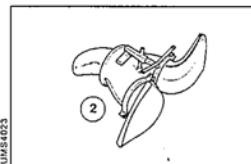

I.2V.CH.S5.01

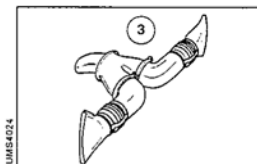

I.2V.L.S5.01

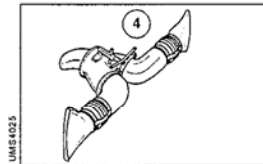

I.2V.LCH.S5.01

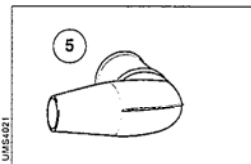

I.GCO.S.01

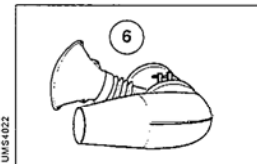

I.GC2.S.01

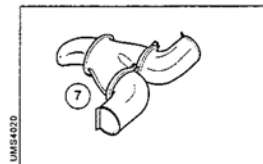

I.2C.S5.01

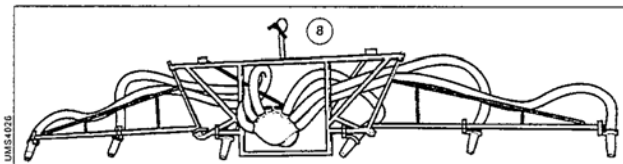

I.BR.S5.44.01

I.BR.S5.65.01

I.BR.S5.66.01

I.BR.S5.88.01

**3.5 - HANDLING OF PHYTOPHARMACEUTICALS**

The operator may be contaminated either by contact with or inhalation of the products and mixtures to be distributed. The environment may be polluted by the spillage of the products, the careless conservation of empty or unwashed packages, and by pouring the products into the water system.

To avoid these risks, the filling operations should be carried out in suitably prepared and adequately equipped areas, or on the treatment site.

**3.5.1 - Storage**

**Permanent/stationary:** the room used should be ventilated and provided with locking doors to prevent the accidental entry of children and unskilled persons.

**Mobile:** this means of storage should have a lock, to prevent children and unskilled persons from opening it in the absence of the operator. All packages, either full or partially used, must be placed in a way so as not to tip over, fall or break during transport.

Both types of storage should:

- have an appropriate container for storing the empty packages, if a special area is not available;
- have access to clean water for washing, through a container or connection to the water tap;
- have access to fire-extinguishers in the presence of inflammables.



- All packages, either full or partially used, should be kept in their original packaging and their labels should always be legible.
- The instructions for storage, use and disposal which are displayed on the original packaging of the products should always be scrupulously respected.

**3.5.2 - Specific equipment**

The preparation or filling area must provide:

- all equipment for the direct, easy introduction of products into the tank;
- all apparatuses necessary for measuring the amount of product to be poured into the tank at each filling;
- all the useful equipment and tools for mixing the powders and cleaning the operator in case of contamination;
- a supply of clothes and preventive measures to avoid contamination either by contact or inhalation during the operative stage of the intervention.

**3.5.3 - Disposal of empty packages and phytopharmaceutical residue**

Phytopharmaceuticals are classified as "special" waste and their disposal must be different from "urban" waste.



- The empty packages and the contaminated containers to be disposed of should not be neglected, burnt or buried in the ground.
- The tank residue and the water mixtures cannot be discharged on the ground or poured into channels, torrents or rivers.

The disposal of special waste is regulated by specific norms. To carry out the operation, it is necessary to obtain the appropriate information at the local competent offices. The non-observance of these laws may cause enormous damages to people, animals and environment.

### 3.5.4 - Personal protection means

The toxicity of phytopharmaceuticals compels the people using them to wear adequately protective clothing and accessories to avoid the risks of contamination by contact or inhalation.



During the filling operation, use protective glasses, masks and gloves.

**The operators must wear:**

- Polyethylene or polyvinyl gloves.
- Complete overalls in waterproof cotton, to guarantee transpiration, with side polypropylene coatings. It is possible to find disposable tyvek overalls that, after use (see picture) must be disposed of in the same way as the toxic waste.
- Half-size mask in neoprene rubber with 1 or 2 filters. It is possible to use filters for gas and organic vapors (European class A1) combined with filters against powder (European class P1) for mists and irritating powders, or P2 for mists and harmful or toxic powders.

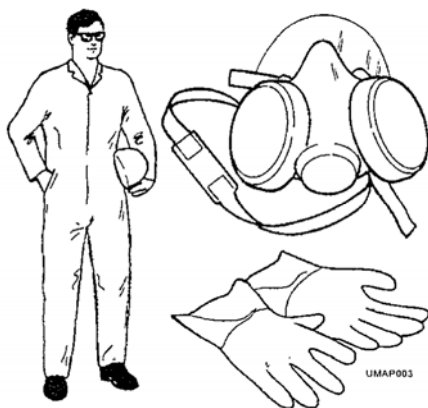

**The filters should be replaced:**

- when you notice odor/taste of phytopharmaceutical, for class A1 with activated carbon;
- when you feel resistance in the breathing function, for classes P1 and P2, against powders.

It is, however, necessary to use all personal protection means according to the suggestions of the manufacturer.

### DETERMINING LENGTH

Line the PdP up perfectly on the same axis and measure the distance "D" between their grooves. The length "L" of the drive joint to be used, measured between the two stop keys and with transmission closed, should be 25 mm shorter than the distance "D" (see decal). The insertion, the disassembly or other possible interventions on the drive joint should be carried out with the water off and the key out of the tractor's control panel.

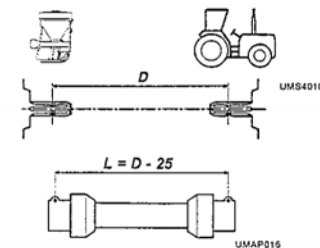

## DISTRIBUTION DEVICES

### TYPES-IDENTIFICATION CODES-WEIGHTS FOR DUSTERS TYPE S420-S430

1 - TWO FISHTAIL.....	I.2V.S4.01.....	weight kg.	6
2 - TWO FISHTAIL WITH RIGHT OR LEFT CLOSURE.....	I.2V.CH.S4.01.....	weight kg.	8
3 - SWINGING CANON.....	I.GC0.S.01.....	weight kg.	2,5
4 - SWINGING CANON WITH ADDITIONAL FAN.....	I.GC2.S.01.....	weight kg.	5,5
5 - HALZELNUTS.....	I.2C.S4.01.....	weight kg.	6,5

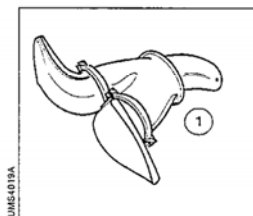

I.2V.S4.01

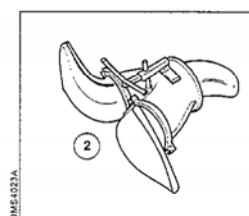

I.2V.CH.S4.01

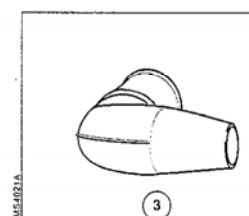

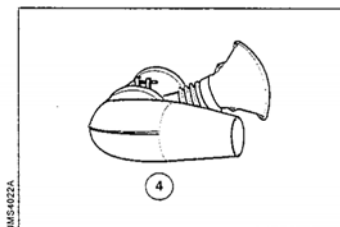

I.GC0.S.01



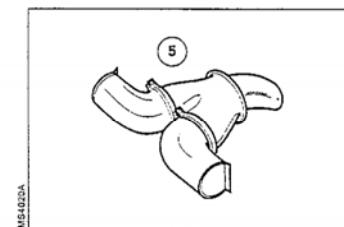

I.GC2.S.01



I.2C.S4.01

3.   Stop the tractor and take the key out of the control panel.

4. Insert the machine gudgeons in the articulated wheels and lock them with the release pins.
5. Take the tension rod off of the tractor's 3rd point and mount it on the machine, locking it with the release pin.
6. Hook the tension back on the tractor, locking it with the gudgeon and the release pin, and screw it slightly to put it in tension.
7. Start the tractor and lift the duster until the 2 PdPs are at the same height.

8.   Stop the tractor, take the key out of the control panel and make sure that nobody touches the hydraulic controls of the hoist. **AVOID STAYING OR OPERATING UNDER THE MACHINE OR ON ITS SURFACE WHICH IS SUBJECT TO A SUDDEN LOWERING.**

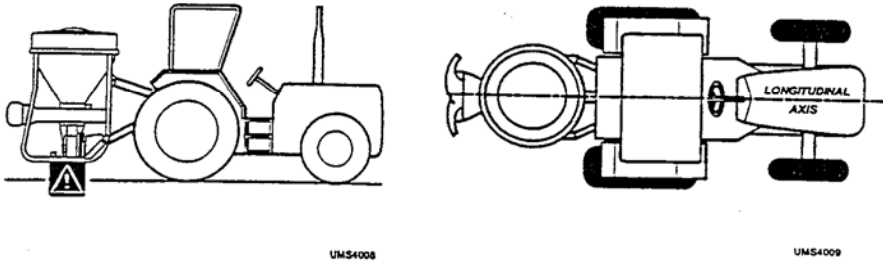

9. By means of the tension rod of the 3rd point, put the axis of the 2 PdPs on the same plane.
10. Lock the coupling by pulling the chains of the hoist arms.

 At the end of the operation the 2 PdPs must be positioned on the same axis.

### 5.2.- DRIVE JOINT ASSEMBLY

 Use drive joints provided with EEC certificate. **RESPECT THE INSTRUCTIONS CONTAINED IN THE USE AND MAINTENANCE BOOK DELIVERED BY THE MANUFACTURER OF THE JOINTS.**

 The drive joint must work with the 2 COAXIAL PdPs, or, if this is not possible with PARALLEL axis. In this case, misalignment should PREVENT the articulation of the drive joint from working with angles wider than 15°.

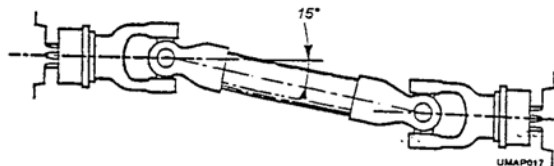

## 4 STRUCTURAL ANALYSIS OF THE MACHINE 4

The picture shows the position of the duster.

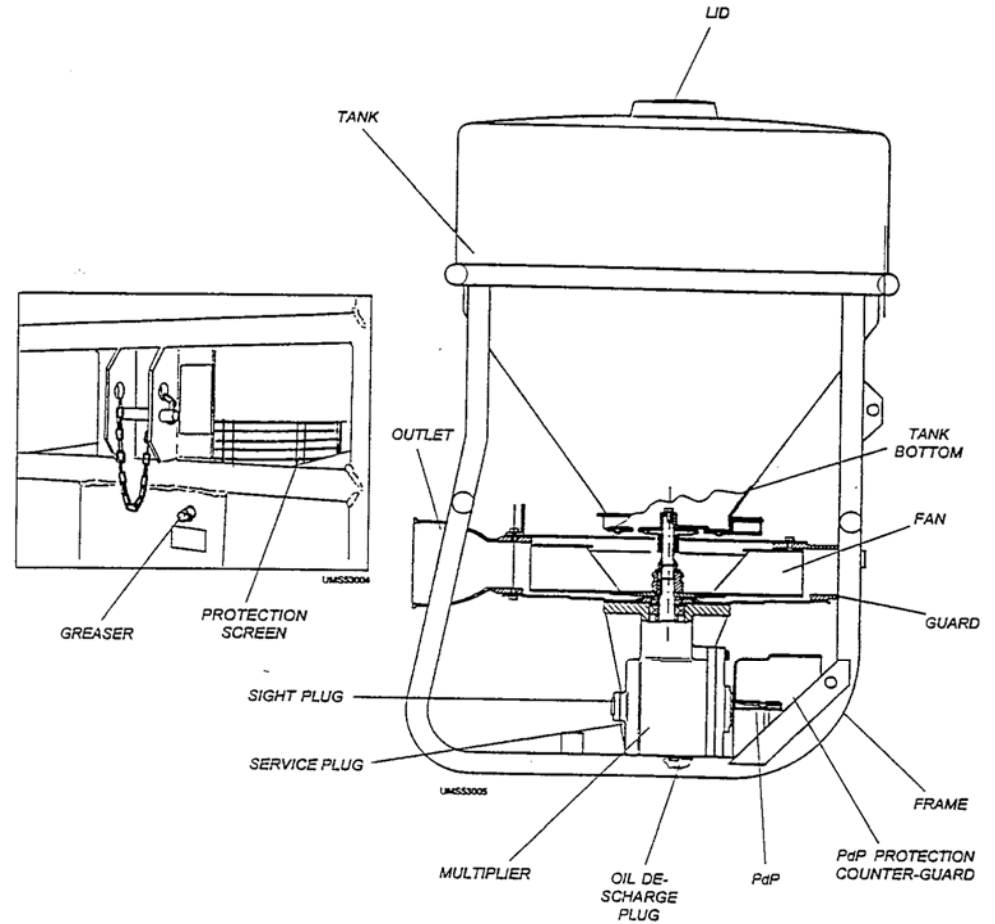

Mounted Duster, main components

#### 4.1 - TANK

- Tanks and lids are in polyethylene.
- Rubber closing tab.



- Before opening the lid, stop the tractor and take the key out of the control panel.
- Check that the lid is closed before starting the tractor again.

#### 4.2 - TANK BOTTOM

- It is made of aluminum and has 4 holes to let the powder fall. A distributing mixer controlled by the multiplier rotates. Underneath it, there is a register with 4 holes which allows the adjustment of the powder distribution.
- Between the lid with bush, which attaches the register to the bottom, and the pinion driving the mixer, is a felt seal against powders. Its functionality is guaranteed by a greaser inserted on the lid.

#### 4.3 - FAN

- Aluminum guard with rear outlet.
- Centrifuge fan enclosed in steel.
- A grill protects the entire suction part.

#### 4.4 - MULTIPLIER

- Aluminum body. On the side opposite the PdP. It has a sight plug for filling and checking the oil level; at the center there is another service plug to make interventions on the conical couple easier; underneath discharge plug.
- Conical Couple with high-tensile steel helicoidal teeth, dimensioned with a wide safety margin that works in oil bath. N.B.: The crown and its shaft are head blocked.
- PdP protection counterguard attached on the multiplier cover.



The multiplier should work with PdP at 540 rpm. This limit must never be exceeded during the use of the machine.

#### 4.5 - CAPACITY REGULATOR

The small square-type indicator slides on a graduated scale from 0 to 6, of the bayonet support of the remote control. It shows the width of the opening of the distribution holes. "0" means full closure, "6" maximum delivery. The handle locks the small square that keeps the opening of the control lever in the desired position.

#### 4.6 - FRAME

The frame may be coupled to hydraulic hoists of class "1". The diameter of the gudgeon is 22mm. The pin of the third point is 19mm. in diameter.

#### 4.7 - TECHNICAL DATA

	ESSE 420	ESSE 430	ESSE 520	ESSE 530
<u>Dimensions and weights without head</u>				
LENGTH mm	1225	1225	1235	1235
WIDTH mm	935	935	935	935
HEIGHT mm	1175	1325	1440	1590
NO-LOAD WEIGHT kg	103	105	136	138
FULL-LOAD WEIGHT kg	233	305	266	338
<u>Technical characteristics</u>				
TANK CAPACITY litres	200	300	200	300
TANK CAPACITY kg	130	200	130	200
MULTIPLICATION RATIO	1 : 5,8	1 : 5,8	1 : 5,8	1 : 5,8
PdP SHAFT	1 3/8" SAE DIN 9611/A	1 3/8" SAE DIN 9611/A	1 3/8" SAE DIN 9611/A	1 3/8" SAE DIN 9611/A
MULTIPLIER SAE 90 OIL kg	1	1	1	1
REAR OUTLET DIAAMETER mm	130	130	130	130
FAN DIAMETER mm	400	400	500	500
FAN SPEED rpm	3130	3130	2800	2800
AIR FLOW-RATE m <sup>3</sup> /h	2100	2100	3470	3470
AIR VELOCITY m/sec	90	90	90	90
ABSORBED POWER at PdP hp- kW	8 - 5,9	8 - 5,9	12 - 8,8	12 - 8,8
EQUIV. AVARAGE SOUND LEVEL L qA	90,2 ± 0,2	90,2 ± 0,2	98,9 ± 0,2	98,9 ± 0,2



The weight of the different heads is given in their specific documentation, and must be added to the machine and cardan joint weight.

5

### COUPLING MODE

5

#### 5.1 - TRACTOR HOOK-UP



Check that the "admitted transported weight" and the "admitted rear projection" of the tractor are compatible with the duster weight at full load and complete with the equipment for treatment (see para. 3.1 and 4.7).



PdP of the tractor should deliver a power higher than that absorbed by the duster in every working condition.

**COUPLING POWER WITH TRACTORS OF AT LEAST**

**15 HP (11 KW) FOR DUSTER TYPE S420-S430 20 HP (14,7 KW) FOR DUSTER TYPE S520-S530**

The duster should be mounted on a flat surface, taking care to clear away all people not involved in the operation, including children and animals.

EXECUTION:

1. Slack the chains of the hoist arms.
2. Start the tractor and bring the hoist arms to the height of the machine gudgeons.