

PLUS



OPERATION AND MAINTENANCE INSTRUCTIONS



Atomizzatori e Impolveratori

Dear Customer, thank you very much!

*We want to congratulate with you, for having chosen a **cima**[®] sprayer.*

Your choice shows the wisdom of the well-informed Purchaser, aware of the fact, that the required features of quality, technique and reliability must be satisfied at the right price!

Our continuous engagement in R&D and in testing our machines allows us to realize products able to offer the best performances, a high reliability and a great easiness of use at the same time !

Our first goal, is to get our Customers happy for having met us!

The "Spare parts catalogue" of this sprayer/sprayhead is available in the "restricted area" on website www.cima.it.

In order to accede, use:

User name: **sprayer**

Password: **844719KE**

Mounted Sprayers

Plus

Model:

Serial Number:

(Publication N° LUM-PLUS-08-EN)

OPERATION AND MAINTENANCE INSTRUCTIONS

© CIMA S.p.A. - 2000-2008 PRIVATE PROPERTY.
ANY REPRODUCTION, EVEN IF PARTIAL, IS FORBIDDEN IF NOT PREVENTIVELY AUTHORIZED IN WRITING BY THE
CIMA S.p.A. COMPANY.



CIMA S.p.A. - 27040 Montù Beccaria - Loc. Molino Quaroni - (PV) - ITALIA
Tel. +39.0385.246636 r.a. - Fax +39.0385.246637
<http://www.cima.it>

LISTING OF VALID PAGES

This publication consists of 78 pages, subdivided as follows:

N° OF PAGE	REVISION	BASE
da I a VI	08	November 2008
da 1 a 72	08	November 2008

ADDITIONAL RECORDS AND VARIANTS

REVISION	DESCRIPTION
00	First edition, June 2000
01	Second edition, November 2000
02	Revision, December 2001
03	Third edition, January 2002
04	Revision, April 2003
05	Revision, May 2004
06	Revision, March 2005
07	Revision, September 2008
08	Update, November 2008

GENERAL INDEX

1	FOREWORD	1
1.1	PUBLICATION IDENTIFICATION	1
1.2	ATTACHED PUBLICATIONS	1
1.3	PURPOSE OF PUBLICATION	1
1.4	REFERENCE TO REGULATIONS	1
1.5	USING THE MANUAL	1
1.6	UPDATES	2
2	GLOSSARY	3
2.1	TERMINOLOGY	3
2.2	ABBREVIATIONS	3
2.3	DECALS	3
3	GENERAL INFORMATION	7
3.1	MACHINE IDENTIFICATION	7
3.2	TECHNICAL ASSISTANCE	7
3.3	SAFETY NOTICES	7
3.4	SAFETY SYSTEMS	8
3.5	HANDLING OF AGRO-CHEMICALS	9
3.5.1	Storage	9
3.5.2	Specific equipment	9
3.5.3	Disposal of empty containers and agro-chemical residues	9
3.5.4	Personal means of protection	10
4	MACHINE STRUCTURAL ANALYSIS	11
4.1	FRAME	12
4.2	FAN SERVO AMPLIFIER	13
4.3	HYDRAULIC CIRCUIT COMPONENTS	14
4.4	TECHNICAL DATA	26
4.4.1	Sprayers dimensions and weights	26
4.4.2	Centrifugal Pump CD32	26
5	COUPLING MODALITIES	27
5.1	HITCHING TO THE TRACTOR	27
5.2	MOUNTING OF THE TRANSMISSION SHAFT	28
5.3	INSTALLATION OF REMOTE CONTROLS	29
5.3.1	Manual 2-tap distributor - P9	29

5.3.2	Electrical control panel - E10	29
5.3.3.	E.P.A. Control unit	30
6	DISTRIBUTION DEVICES	31
6.1	POSITIONING OF FAN CASING	32
6.2	ELBOW FITTINGS OF DISTRIBUTION DEVICES	32
7	ACCESSORIES	33
7.1	FILLER PIPE	33
7.2	PAIR OF WHEELS	33
7.3	SWIVELLING DEVICE	34
7.4	E.P.A. Kit DELIVERY PROPORTIONAL ADVANCEMENT	35
8	FILLING	36
8.1	FOREWORD – USE OF THE FAN DISENGAGEMENT	36
8.1.a	Disengagement of the fan	36
8.1.b	Fan engagement to perform the treatment	37
8.2	FILLING THROUGH POURING FROM THE TOP	37
8.3	FILLING WITH THE SPECIFIC PIPE	38
9	AGITATION	41
10	OPERATING PROCEDURES	41
10.1	PRELIMINARY OPERATIONS TO TREATMENT	41
10.2	PREPARATORY OPERATIONS TO TREATMENT	42
10.3	THE TREATMENT	43
10.4	PROCEDURE TO WASH THE HYDRAULIC CIRCUIT (HEAD-PUMP)	44
10.5	END OF TREATMENT - STORAGE	45
10.5.1	Daily	45
10.5.2	End of seasonal cycle	46
11	TANK AND HYDRAULIC CIRCUIT DRAINING	47
12	LIFTING AND TRANSPORT	48
13	MAINTENANCE OPERATIONS	49
13.1	LUBRICATION	49
13.2	FAN SHAFT SUPPORT OIL LEVEL CHECK	50
13.3	FAN SHAFT SUPPORT OIL REPLACEMENT	50
13.4	CLEANING OF FILTER'S CARTRIDGE	51
13.5	PURGING OF RESIDUES FROM FILTER	51

13.6	CLEANING OF THE FAN	52
13.7	FANBELTTENSIONER	52
13.8	PUMPBELTTENSIONER	53
13.9	TANKREMOVAL OR REPLACEMENT	53
13.10	TABLE OF MAINTENANCE OPERATIONS	55
14	FAULTS FINDING	56
15	REPAIRS ALLOWED	59
15.1	REPLACEMENT OF PUMP CONTROL BELT	59
15.2	REPLACEMENT OF ELECTRICAL PANEL'S FUSES	60
15.3	PRESSURE GAUGE REPLACEMENT	60
15.4	INSPECTION AND CLEANING PUMP FILTER	61
15.5	CHECK HYDRAULIC DELIVERY	62
16	INTEGRATIVE DIAGRAMS	61
16.1	HYDRO-PNEUMATIC DIAGRAM	61
16.2	WIRING DIAGRAM	65
17	NOISE LEVEL	66
18	ATTACHMENT : DECLARATION OF COMPLIANCE	67
19	WARRANTY	68

1.1 - PUBLICATION IDENTIFICATION

The "OPERATION AND MAINTENANCE INSTRUCTIONS" manual is an integrative part of the sprayers. It is identified by a Publication No. located on the frontispiece, and through which the document can be identified, traced and/or subsequently referred to.

The information elements contained herein are updated as at the date of publication. C.I.M.A. S.p.A. reserves the right to modify its machines without notice, with the purpose of applying technical enhancements, and it declines all responsibility for possible omissions from the publication. All rights reserved. No parts of this book may be reproduced or utilized in any form or by any means, electronic or mechanical, including photocopying, recording, or by any information storage and retrieval system, without permission in writing by C.I.M.A. S.p.A.

1.2 - ATTACHED PUBLICATIONS

- Spare parts catalogue;
- Distribution devices, "Operation and maintenance instruction"
- Distribution devices, "Spare parts catalogue"
- "Low Volume - Instructions for sprayer adjustment"

1.3 - PURPOSE OF PUBLICATION

All indications contained in this manual are aimed at the user of the sprayer.

The duration of the machine and its operation, the operator's safety and the respect for the environment are dependent upon scrupulous observance of the stated norms.

Before making use of the sprayer, the user must read, understand and abide by all regulations listed in this manual.

1.4 - REFERENCE TO REGULATIONS

This manual was set out conforming to the regulations contained in following documents:

- Attachment "I" to Directive 98/37/CE and subsequent modifications (letters "b", "c" of point 1.1.2 and point 1.7.4);
- UNI EN 907 - 1998 and to all the documents in it quoted.

1.5 - USING THE MANUAL

Read every part of this manual, paying attention to the **WARNING** and **DANGER** indications both on the text and on the machine or on components.

All operations suggested by the manual will have to be followed with the utmost care and only after having understood the negative consequences of improper usage.

The following “**symbols** “ are used within the text in order to highlight and visually identify the importance of the various types of information:



Indicates important additional information



Non observance can result in permanent damage to the sprayer.



Highlights possibly dangerous situations to people.

The manual, with relevant attachments and possible integrating issues, must be kept with the utmost care and must always be complete, integer and legible in every part. Should it be mislaid it is imperative to immediately request a duplicate from C.I.M.A. S.p.A. Should the decals originally applied on the machine be mislaid, damaged or become incomprehensible, they should be promptly replaced.

For every type of distribution device (Head) delivered with the sprayer, a specific user and maintenance manual is attached. All the head manuals must always accompany the one of the machine.



- **The manual must always be kept for the sprayer’s whole operational life.**
- **Any modification received must be permanently inserted in this publication.**
- **The manual must be ceded with the sprayer should this be sold.**

1.6 - UPDATES

Possible updates that C.I.M.A. S.p.A. will provide the owner of the sprayer will be accompanied by instructions to insert in this publication.

Should the machine be sold, the owner must inform the new purchaser that he should notify C.I.M.A S.p.A. of his address in order to receive possible future integrating issues and/or updates.

2 GLOSSARY 2

2.1 - TERMINOLOGY

The terms FRONT, REAR, RIGHT and LEFT utilised in this publication refer to the sprayer as seen by an operator from behind the operative unit along the drive line and facing it: **the rear part** of the machine is that closest to the operator, and is where the distribution device (Head) is mounted - and **the front part** is the one that gets attached to the tractor.

2.2 - ABBREVIATIONS

cm	centimetres
g	grams
h	hour
ha	hectare
ha/h	hectare per hour
l	litres
l/h	litres per hour
l/min	litres per minute
kg	kilogram
kg/cm ²	kilograms per square centimeter (atmosphere)
km	kilometre
km/h	kilometres per hour
L m	width in metres
m	metre
Mesh	N° of meshes per linear inch
Micron	1/1000 of millimetre
m m	millimetres
PTO	power take-off
RPM	revs per minute
s	seconds

2.3 - DECALS

The safety and use/maintenance decals applied to the machine are described in the following paragraph.



Every decal is marked with its part number, in case it needs to be replaced.

Safety

- 1 - 95001 - **STOP THE ENGINE AND REMOVE THE KEY FROM THE TRACTOR'S CONTROL PANEL BEFORE CARRYING OUT ALL MAINTENANCE OR REPAIR OPERATIONS**
 - Positioned on the right-hand side of the tank in the forward part of the machine.
- 2 - 95004 - **DANGER OF CONTAMINATION BY CONTACT OR POISONOUS PRODUCTS INHALATION**
 - Positioned above the tank, on the left-hand side, next to the filler spout.

- 3 - **95005 - DANGER, PARTS IN MOTION. BEFORE REMOVING PROTECTION GUARDS, STOP THE TRACTOR, REMOVE THE KEY FROM THE TRACTOR'S CONTROL PANEL AND ENSURE THAT ALL MOVING PARTS HAVE STOPPED**
 - Positioned on the fan casing next to the outflow vent.
- 4 - **95015 - BEFORE UTILISING THE RELEASE DEVICE, STOP THE TRACTOR, REMOVE THE KEY FROM THE TRACTOR'S CONTROL PANEL AND ENSURE THAT THE FAN HAS STOPPED**
 - Positioned in the forward part of the machine, on the mobile protection cover of the access to the release device.
- 5 - **95010 - MAXIMUM OPERATING SPEED OF THE DRIVE OUTLET (PTO): 540 RPM**
 - Positioned on the forward part of the machine, on the lower part of the tank and close to the drive outlet.
- 6 - **95007 - DANGER OF SPRAYS: KEEP AT A SAFE DISTANCE**
 - Positioned on the upper part of the fan casing.
- 7 - **95006 - WARNING: CONSULT THE USER AND MAINTENANCE MANUAL BEFORE USING OR INTERVENING ON THE MACHINE**
 - Positioned on the right hand side of the tank, in the forward part of the machine.
- 8 - **95009 - DANGER: GLOVES MUST BE USED TO EMPTY THE TANK**
 - Positioned on the right hand side and lower part of the tank, near the discharge lever tap.
- 9 - **95012 - DANGER: MOUNT THE WHEELS AFTER HAVING HITCHED THE MACHINE TO THE HOISTER AND DISMANTLE THEM BEFORE UNHITCHING THE MACHINE FROM THE HOISTER**
 - Positioned on the right hand side and lower part of the tank.

Use and maintenance

- 10 - **95059 - HOOKING POINT FOR THE LIFTING OF THE MACHINE**
 - Positioned on the frame, above the fan's casing.
- 11 - **95079 - CHECK THE OIL LEVEL EVERY 8 HOURS: FAN SHAFT BEARINGS**
 - Positioned on the chassis, over the fan casing.
- 12 - **95054 - GREASE EVERY 200 HOURS: FAN TIGHTENER SUPPORT AND FREEWHEEL**
 - Positioned on the chassis, in the low, rear side, on the left.
 - Positioned in the front section, on the tank, in a low position near the Power Takeoff.
- 13 - **95081 - INDICATION OF THE WHEELS OPERATING PRESSURE (ACCESSORY)**
 - Positioned on the wheel (accessory).
- 14 - **95057 - HAND WASHING TANK TAP**
 - Positioned on the right-hand side of the tank, next to the tap.
- 15 - **95065 - WARNING: NEVER OPERATE THE SPRAYER WITHOUT LIQUID IN THE TANK**
 - Positioned on the forward part of the tank, above the gauge.
- 16 - **95058 - INDICATION ON THE OPERATION OF THE 3-WAY TAP (P5)**
 - Positioned on the 3-way tap.
- 17 - **95084 - INDICATION ON THE OPERATION OF THE RINSING TAP (P16)**
 - Positioned on the right side, under the tank (For models on which it is foreseen)

Positioning of the safety, use and maintenance decals

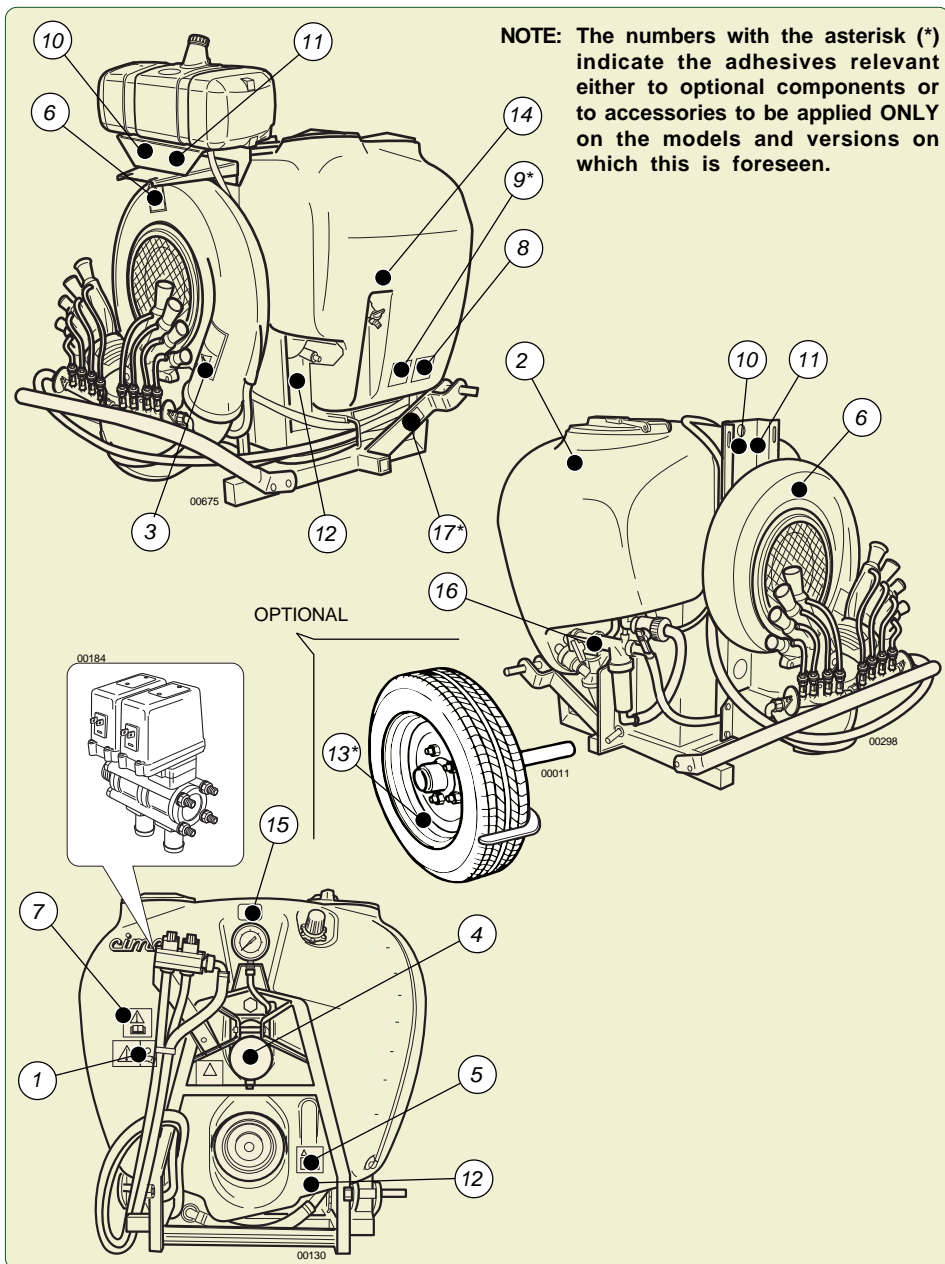

* Safety decals

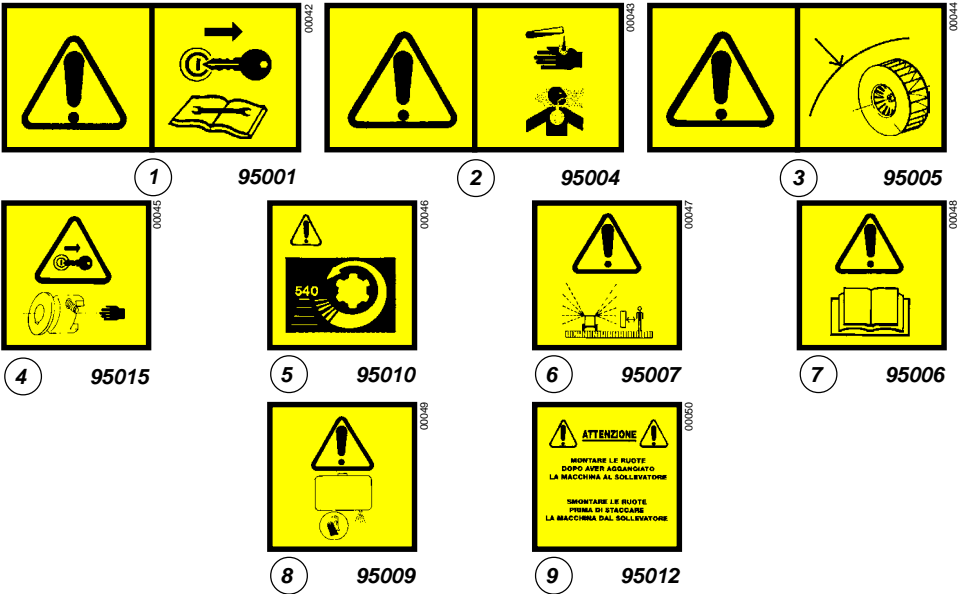

* Use and maintenance decals

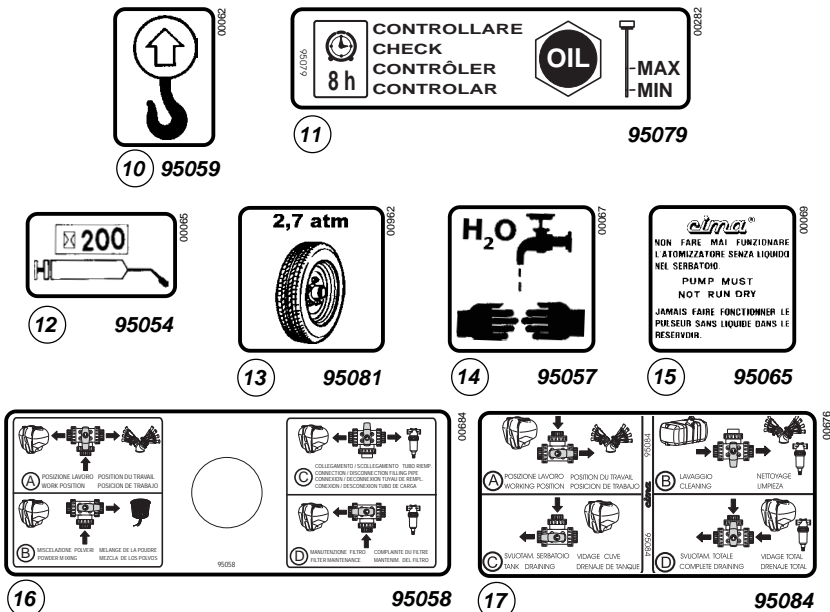

3.1 - MACHINE IDENTIFICATION

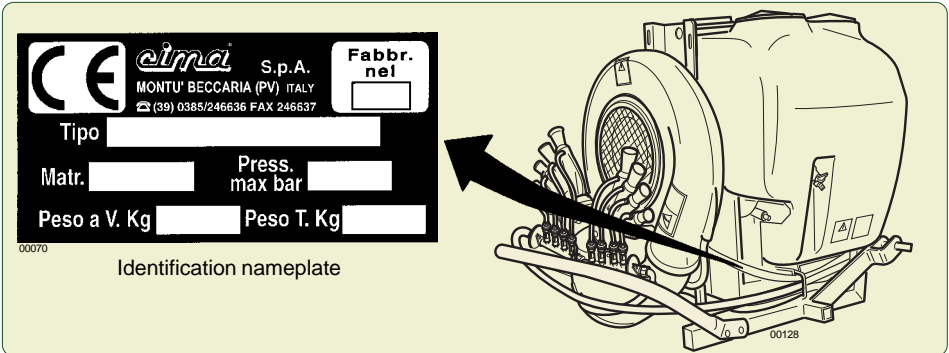

3.2 - TECHNICAL ASSISTANCE

C.I.M.A. S.p.A. is at the complete disposal of customers for any type of intervention. The names and addresses of its service network, both in Italy and in foreign countries, can be requested from:

C.I.M.A. S.p.A. - 27040 Montù Beccaria - Loc. Molino Quaroni (PV) - ITALIA
tel. 0385-246636 - fax 0385-246637
from abroad tel. +39-0385-246636 - fax +39-0385-246637
e.mail service@cima.it

3.3 - SAFETY NOTICES

All the preparation, use, maintenance, moving and transporting operations must be carried out only after having acquired a perfect knowledge of the regulations contained in this publication and the ability to appropriately interpret the symbols of the decals applied to the machine.



IT IS FORBIDDEN TO UTILISE THE SPRAYER FOR PURPOSES OTHER THAN FOR ITS INTENDED USE, SINCE IT WAS MANUFACTURED ONLY FOR SPRAYING AGRICULTURAL CROPS WITH ANTI-PARASITIC PRODUCTS.

It is necessary to scrupulously abide by the following general norms:

- always stop the tractor's engine before carrying out any operation on the sprayer;
- check that the weight and power of the tractor are compatible with the sprayer to be used;
- before utilisation, check the correct tightening and securing of the machine's various components, paying particular attention to the safety protections and to the moving parts;
- only utilise protected cardan shafts provided with CE conformity certification.
Carry out the assembly only if the drive outlets of both tractor and sprayer are equipped with the protection counter-guard;
- check that the cardan shaft is blocked by the appropriate anti-rotation chains;

- keep people and animals away from the machine before starting it up;
- don't wear articles of clothing that might get caught in moving parts;
- keep to a low speed while negotiating bumps or crossing ditches.



- All maintenance and repair operations must be carried out only after having rinsed the tank and flushed the system.
- Before operating within the tank it is necessary to wash it thoroughly with clean water.
- It is forbidden to perform welding operations if ammonium salts were previously used.
- It is forbidden to use the machine within a potentially explosive environment.
- The application of paints and/or solvents, the washing of closed environments and machinery as well as the utilisation of the air flow for purposes other than those expressly concerning the spraying of agro-chemicals is not permitted.
- It is forbidden to enter the tank.

3.4 - SAFETY SYSTEMS

All machine moving parts are suitably protected by guards and highlighted through the use of warning decals.



- It is forbidden to use the machine with these guards removed.
- Before removing the protection, stop the tractor's engine and remove the key from the control panel.

The pictures illustrate the machine's guarded parts:

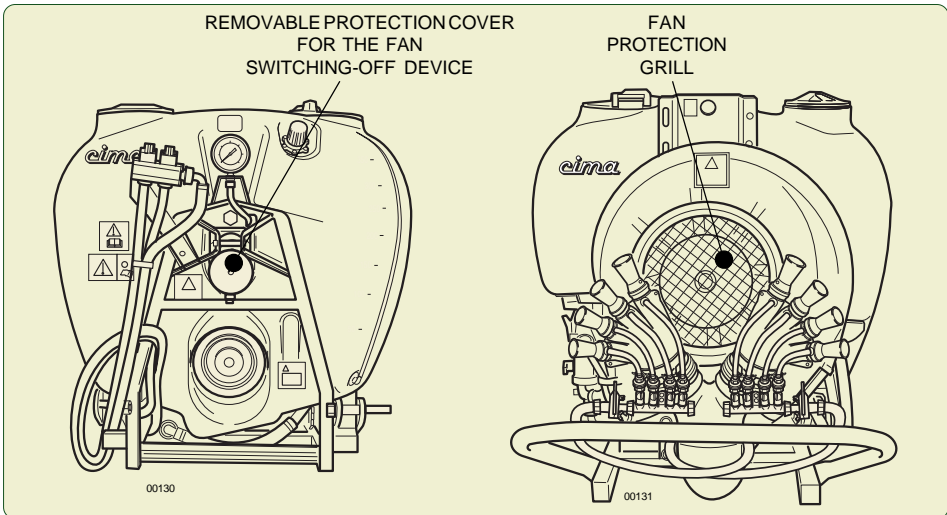

THE OWNER AND/OR THE OPERATOR OF THE SPRAYER ARE NOT PERMITTED TO MODIFY THE STRUCTURE OR THE SPECIFIC OPERATION OF THE SPRAYER ITSELF. ANY REPAIRING INTERVENTION HAS TO BE CARRIED OUT EITHER AT THE DEALERS' OR AT THE C.I.M.A. S.p.A. AUTHORIZED WORKSHOPS, OTHERWISE ANY KIND OF WARRANTY IMMEDIATELY CEASES AND C.I.M.A. S.p.A. IS CLEARED OF ANY CONSEQUENT AND/OR IMPLIED RESPONSIBILITY.

3.5 - HANDLING OF AGRO-CHEMICALS

The **operator** could become contaminated due to accidental spray, contact or inhalation of products or crop-spraying mixtures.

The **environment** could become polluted by mixture over-spills, puncturing of containers, uncontrolled storage of used and unwashed containers or spillage into waterworks.

In order to avoid these risks the preparation and filling operations must be carried out in suitably appointed and adequately equipped sites.

3.5.1 - Storage

Fixed / stationary: the site used must be well ventilated and secured by lockable doors in order to prevent even accidental access by children or unauthorised persons.

Mobile: the carrier equipment must be properly locked and kept under conditions whereby access by children or unauthorised persons can be prevented during the absence of the operator. All full or partially utilised containers must be secured against tipping, falling or breakage during transportation.

Both types of storage must:

- have a suitable container for the storing of empty packaging materials should a specific storage area not be available;
- have a clean water supply readily available for washing, by means of a specific container or through connection to the waterworks system;
- have the use of fire extinguishers, should flammable products and substances be stored.



- **All packages, whether whole or partially utilised, must be stored in their original packing and with the warning instructions clearly displayed and legible.**
- **The storage indications must always be scrupulously adhered to, as well as their utilisation and possible disposal as suggested on the product's original packaging.**

3.5.2 - Specific equipment

The site at which the preparation and filling out will take place must provide for:

- all the equipment necessary to the precise measuring of both the water quantity and the dose of product to be mixed in the tank at every filling;
- all the equipment and means useful to the preparation of the mixture and for the cleaning of the operator in case of contamination;
- all tools necessary to facilitate the direct introduction of the agro-chemicals in the tank;
- the allocation of clothing and specific equipment in order to avoid contamination by contact or inhalation during the whole operative phase of the intervention;
- the availability of proper equipment able to stop the uncontrolled spilling and flowing of the mixture;
- a retaining valve on the feed pipe when the filling of the tank takes place directly from the waterworks system.

3.5.3 - Disposal of empty containers and agro-chemicals residues

Agro-chemicals are classified as "special" waste and their disposal must take place separately from "urban" wastes.



Empty packaging and contaminated containers to be done away with cannot be dispersed, burned or buried.

The washing water for the cisterns and the tools utilised for the preparation of mixtures cannot be emptied on the ground, spilled into the sewage system or in waterways and rivers.

The disposal of special wastes is regulated by specific norms. In order to perform this operation it is necessary to obtain the relevant information from the Local Offices specifically appointed to rule on this subject. The non compliance with these regulations can cause considerable damage to persons and animals as well as polluting the environment.

3.5.4 - Personal means of protection

The toxicity of agro-chemicals forces persons working with them to wear adequate protective clothing and accessories in order to avoid risks of contamination by contact or inhalation.

In each of the following work stages:

- filling of tanks and adding of the agro-chemical,
- dusting and spraying,
- adjusting of the sprayer,
- emptying and cleaning of the tank,
- replacement of the agro-chemical,
- maintenance interventions,

it is necessary to wear personal protection clothing and accessories.

The following must be worn:

- Polyethylene or polyvinyl gloves.
- Full, waterproof cotton overalls, in order to guarantee transpiration, fitted with polypropylene side flaps.
In commerce, one-time 'tyvek' overalls are available which, after use (see picture), must be disposed of according to the modalities applicable to toxic waste.
- A protective half-mask in polychloroprene rubber with 1 or 2 filters. Filters for gases and organic fumes, of European A1-class vapours, are envisaged and these can be combined with anti-dust models of P1 European class, for harmful mists and powders, or P2, for harmful and toxic mists and powders.



The filters must be replaced:

-when the smell/taste of agro-chemicals can be detected, and that of active A1-class carbons;

-when difficulty in breathing is experienced for the anti-dust filters of class P1 and P2.

In any case it is necessary to make use of all personal means of protection as suggested by the manufacturers.

4 MACHINE'S STRUCTURAL ANALYSIS 4

The pictures indicate the position of the main components of the sprayer.

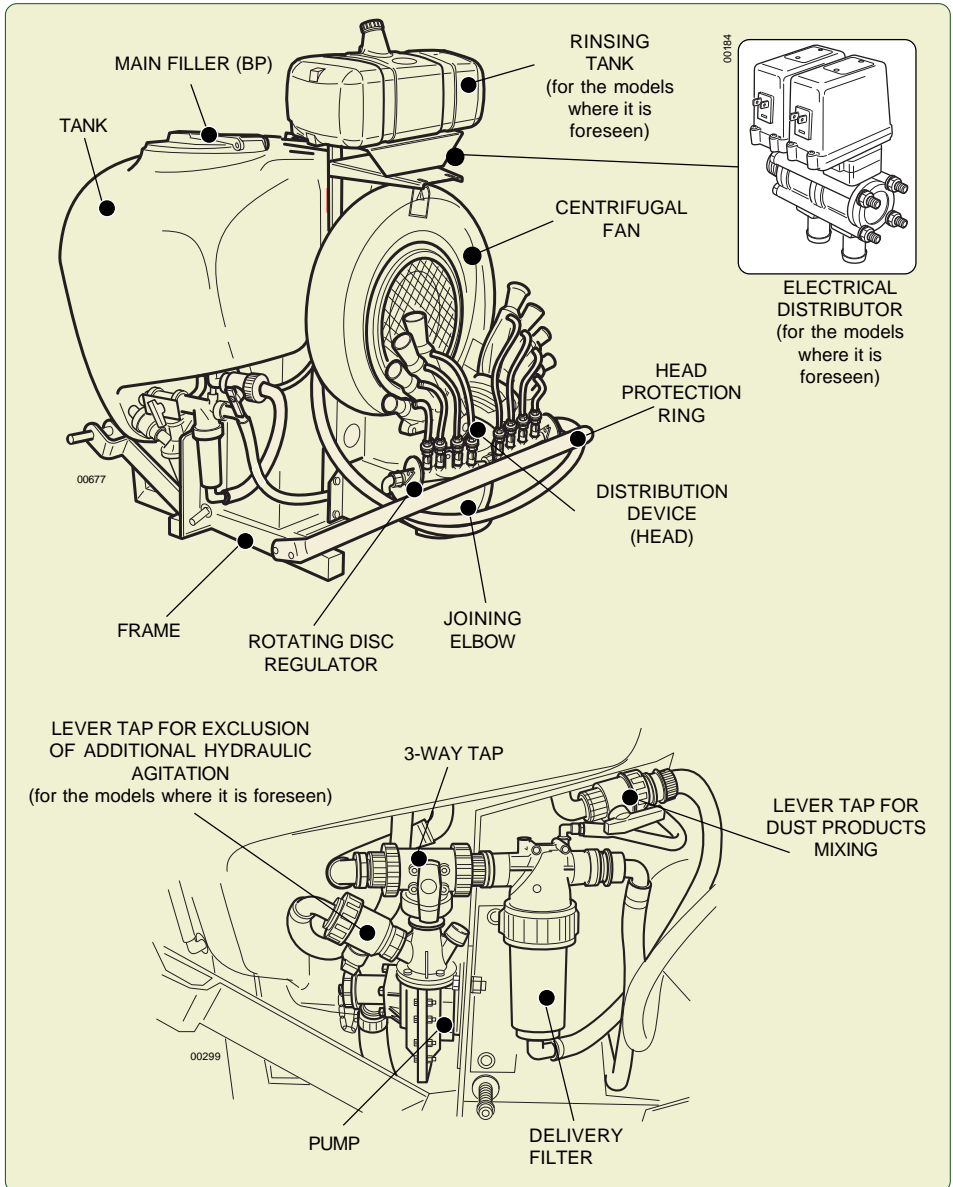

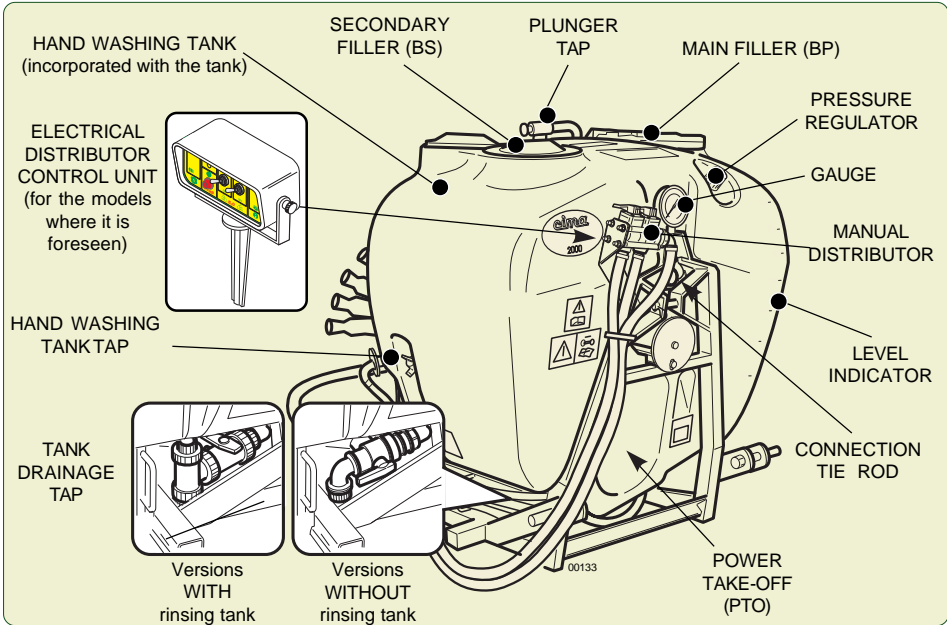

4.1 - FRAME

Frames of series Plus 42 and 45 can be coupled to category “1” three-point linkage. The plugs diameter is 22 mm. The diameter of the third-point plug is 19 mm.



In order to limit the shifting of the centre of gravity and to implement a functional coupling, ALL frames allow for the double positioning of plugs

Frames of series Plus 50, 55, 55S and 55E can be coupled to category “2” three-point linkage. The plugs diameter is 28.5 mm. The diameter of the third-point plug is 25 mm.

- The tank-securing bracket is mounted by means of 2 screws on the front, below the 3rd point. (see Paragraph 13.9).
- A tie-rod through the tank’s upper tunnel connects the front part of the frame to the rear. This must be dismantled should the tank be removed and it must be repositioned after having re-assembled the tank.
This operation is carried out from the front, below the 3rd point connection, by means of a spanner supplied with the machine.
- In the forward part, below the 3rd point connection, the removable protection cover of the fan release device is secured by means of a screw.

A rear bumper is provided to protect the sprayhead. This must be mounted in the most effective position, according to the operating conditions and in keeping with the type of heads utilised.

A chain with hooks, fixed to the front part of the frame, allows the support of the transmission joint when the machine is coupled to the tractor.

All frames are pre-set with axles for the application, on request, of a pair of wheels (see Paragraph 7.2).

4.2 - FAN SERVO AMPLIFIER

Servo amplifier

It is equipped with an automatic tensioner of the driving poly-V belts that keeps the belt tension constant, avoiding slipping and wear. **A free-wheeling gear is included** between the Power Take-off of the servo amplifier and the fan control pulley (for versions on which it is foreseen). In case of sudden decelerations or unexpected engine stoppage, this allows the fan to continue its free rotation, thus avoiding extreme mechanical stresses to be transmitted to the drive members.

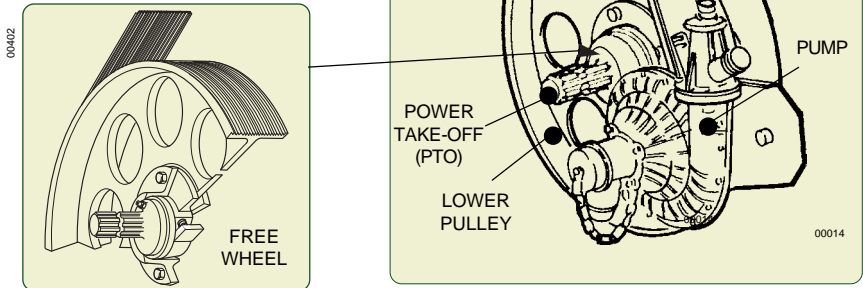

Centrifugal fan

The front-engaging clutch assembled on the fan shaft allows the operation of the centrifugal pump without the fan. (for versions on which it is foreseen).

The fan housing can rotate 360 degrees. This permits the positioning of the outlet spout at the point necessary for the assembling of the different distribution devices.

An air intake, pre-set on the outer edge of the housing, is connected to the plunger tap placed above the tank. Through this tap it is possible to carry out or exclude pneumatic agitation. The closed blades' impeller is sheet steel realized and dynamically balanced; the air intake opening on the casing is protected by a steel grating.

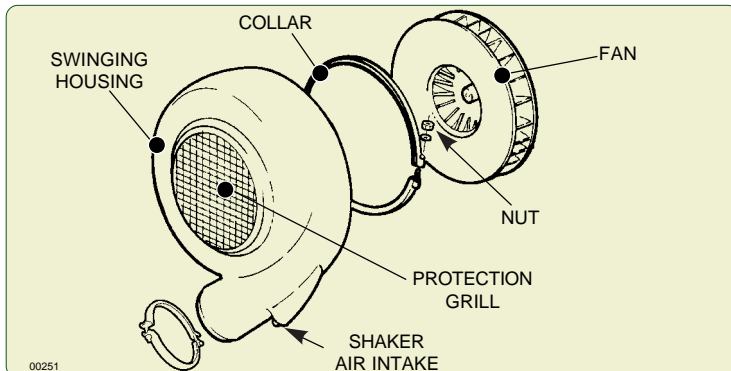

4.3 - HYDRAULIC CIRCUIT COMPONENTS

LEGEND:

P - E = elements of the circuit

T = piping

* = For versions in which this is envisaged

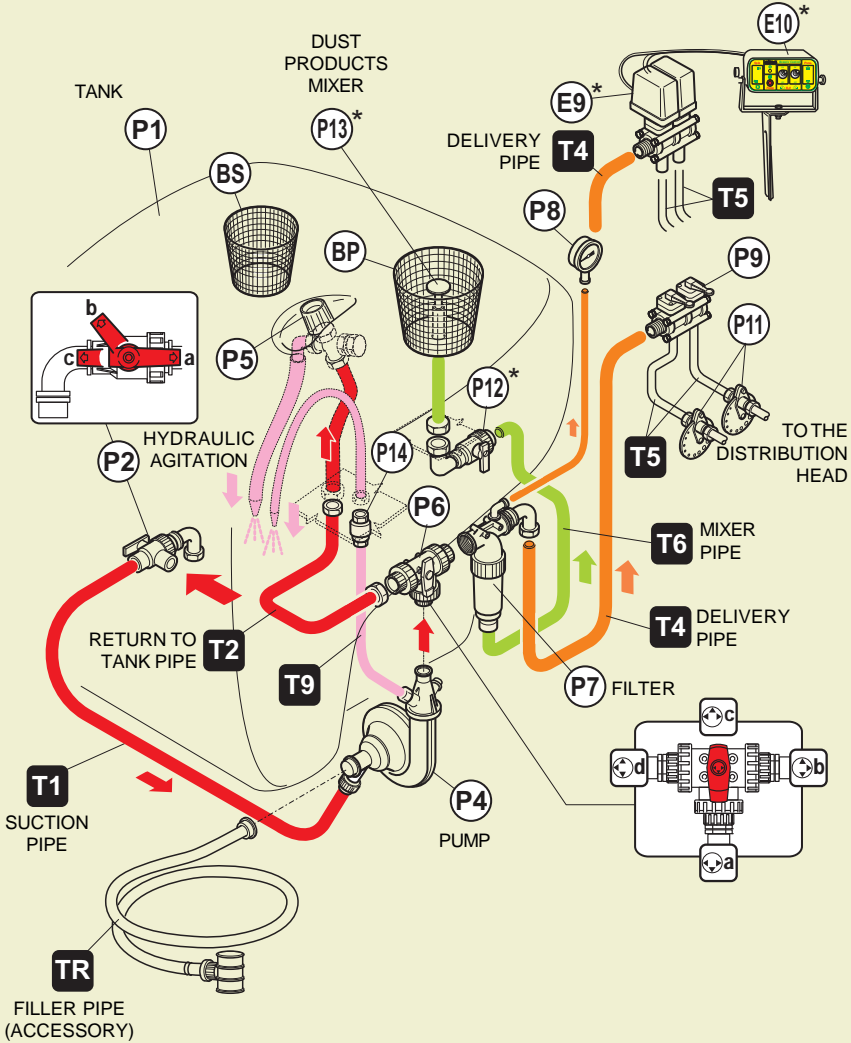

Hydraulic connections diagram

00243

Versions with spray-line rinsing tank

LEGEND:

P - E = elements of the circuit

T = piping

* = For versions in which this is envisaged

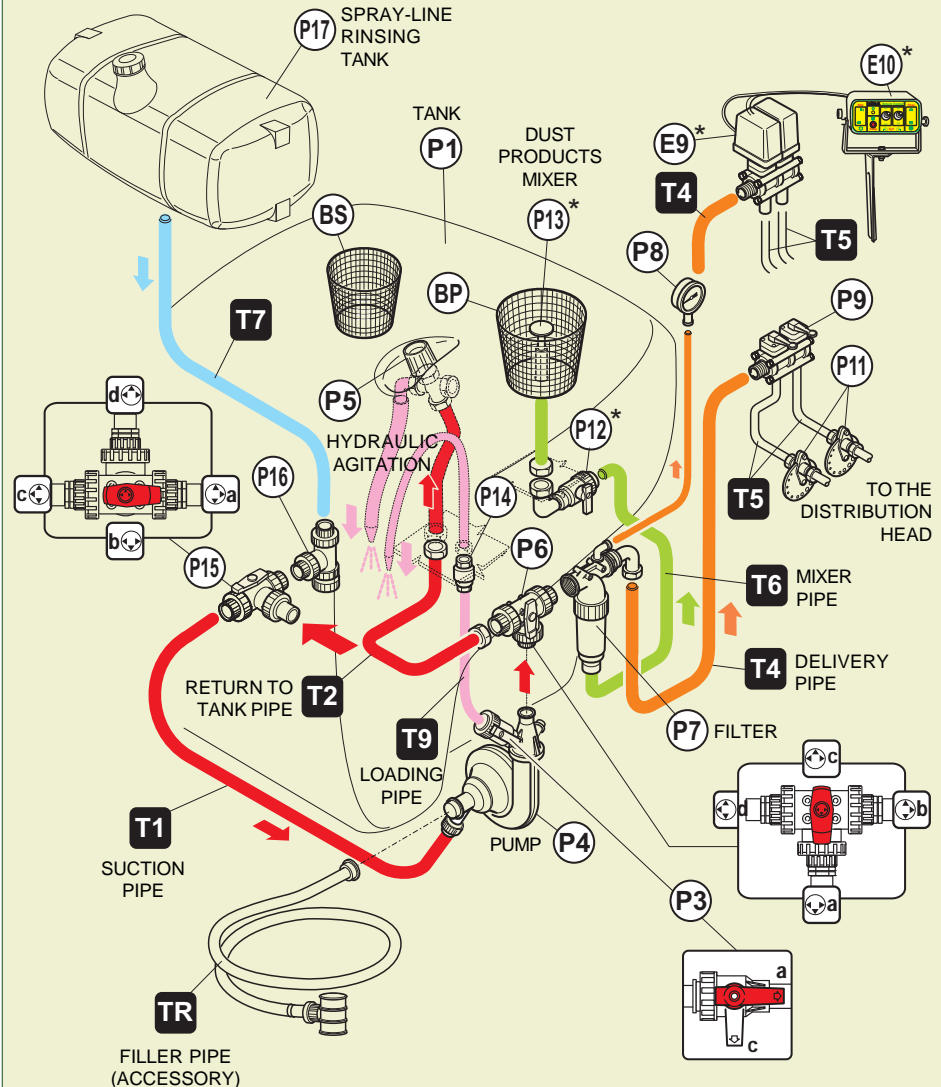

Hydraulic connections diagram

00678

E.P.A. Versions

LEGEND:

P - E = elements of the circuit

T = piping

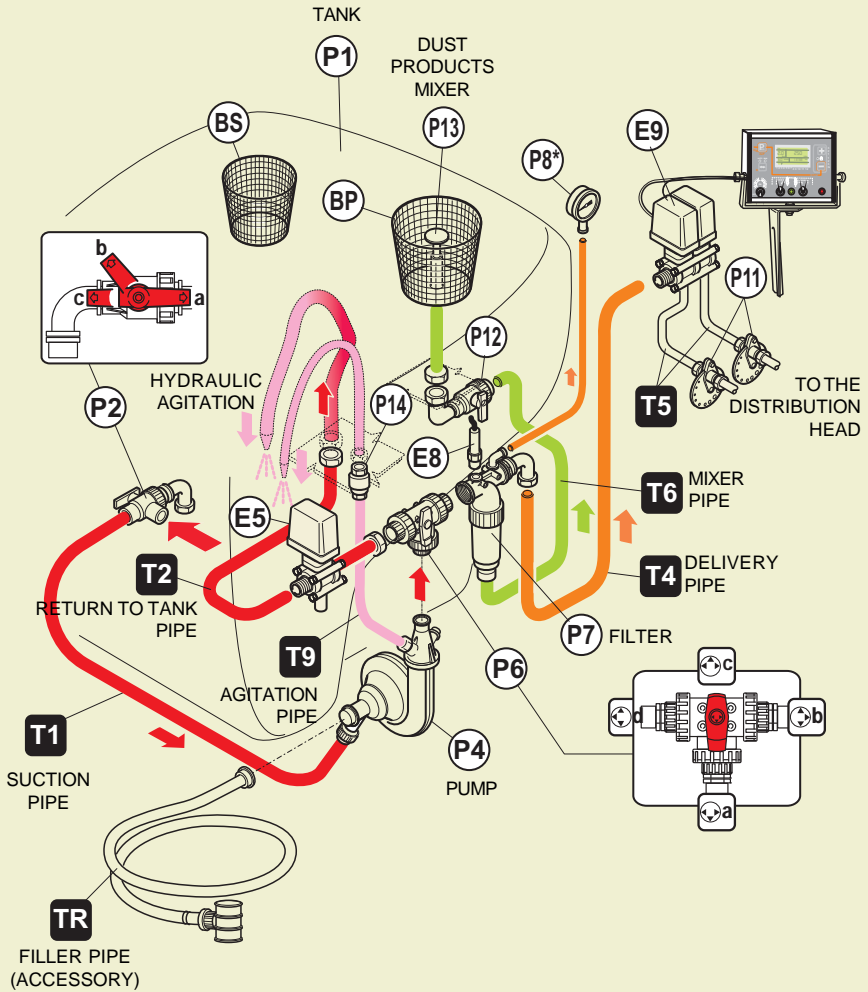
Hydraulic connections diagram

00964

E.P.A. Versions with spray-line rinsing tank

LEGEND:

P - E = elements of the circuit

T = piping

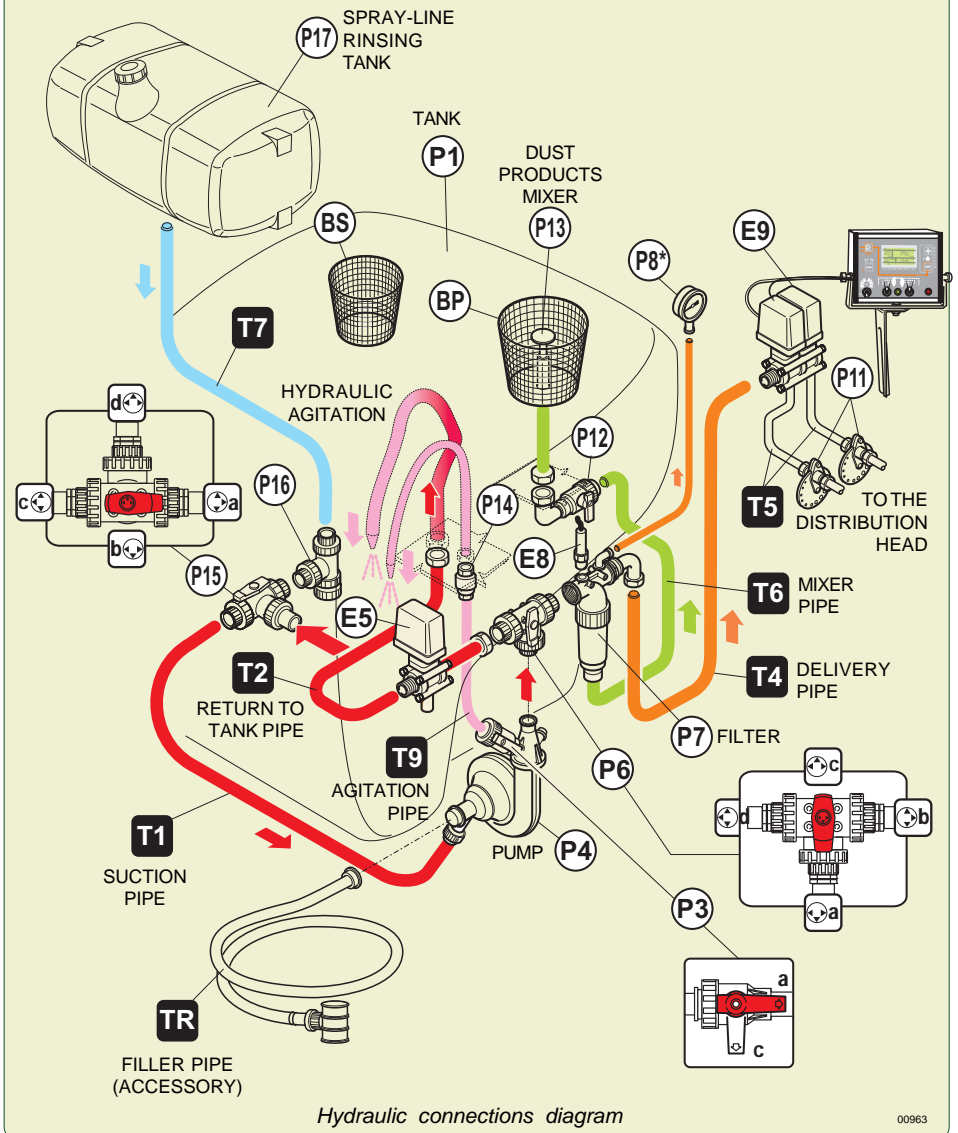

P1. TANK

Tanks utilised:

polyethylene tanks of 300, 400 and 600 litre capacity.

Each tank is made up of:

- tank main filler spout of 355 mm diameter, with collapsible lid, breather and labyrinth seal, for the filling with spraying products. Plastic cup-like filter: 302 mm external diameter, height 254 mm with powder mixing device (for versions in which this envisaged);
- supplementary tank filler with 250 mm diameter screw-type lid, for filling with clear water and plastic cup-like filter: external diameter 204 mm, height 240 mm;
- transparent level indicator external pipe with graduated scale;
- hydraulic agitation system connected to the regulator (P5) and to the pump (P4).
- pneumatic agitation, connected to the piston tap found above the tank and connected through piping to the air intake located on the fan casing.

A = OPEN

C = CLOSED

P22. HAND WASHING TANK

Incorporated polyethylene 17 litre capacity hand wash tank, with external service tap; opening through a 255 mm diameter screw lid.

P2 - 3-WAY LEVER TAP A WITH DISCHARGE FITTING

Fixed to tank (P1) and connected to the suction piping (T1).



With the machine in operation the tap's lever must face towards the suction piping (position "a").

By positioning the lever towards the drain plug (position "c"), total draining of the tank is obtained.

In order to carry out the complete discharge of any liquid remaining in the pump and pipes, set the tap to position "b".

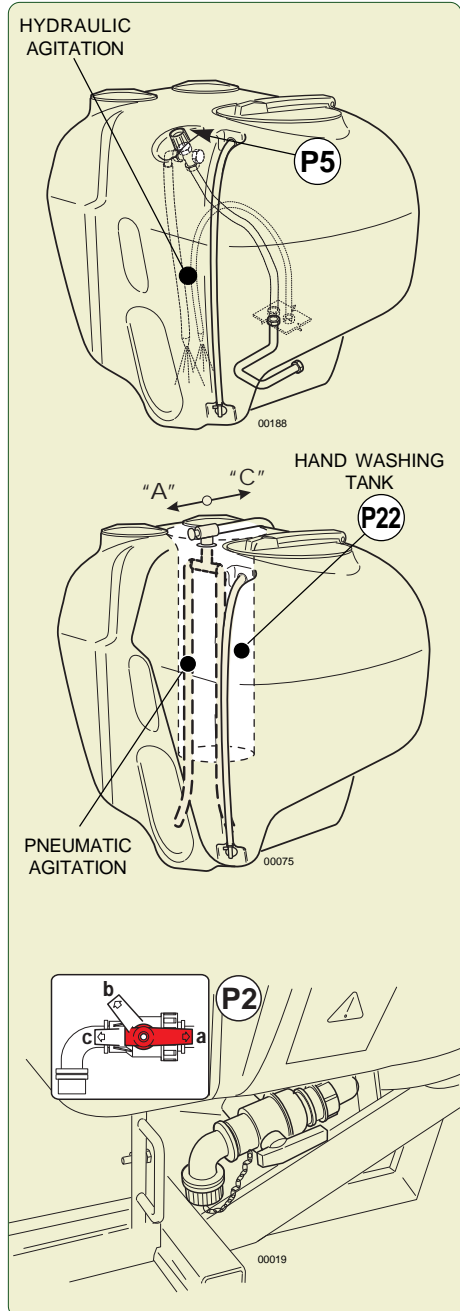



Remove the filler cap before shifting the drain cock lever. When the draining has taken place, return the lever to the working position (position “a”) and screw the cap back on. These operations must be carried out with the machine stopped.

P16 - DISCHARGE CONNECTION WITH PLUG (Versions with rinsing tank)

Connected to the spray-line rinsing tank trough suction piping (T7) and fixed to rinsing tap (P15).

- By positioning the lever in position “c”, draining of the tank is obtained.:
- In order to carry out the complete discharge of any liquid remaining in the pump and pipes, set the tap (P15) to position “d”.



Remove the filler cap before shifting the drain cock lever. When the draining has taken place, return the lever to the working position (position “a”) and screw the cap back on. These operations must be carried out with the machine stopped.

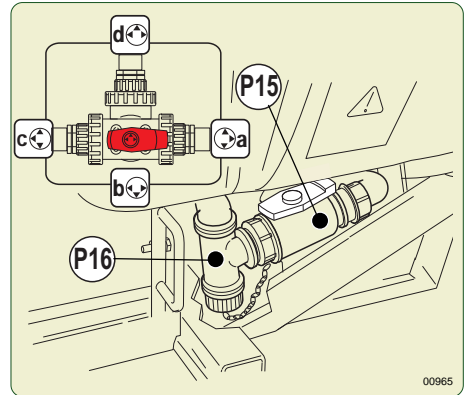

P4 - CENTRIFUGAL PUMP

Fixed to the left-hand side of the machine, it is connected to the tank through the pipeline (T1), to the three-way faucet (P6) and to the hydraulic agitation system for the mixture. The pump is provided by the suction side of a filter to prevent the accidental entry of foreign bodies in the pump body, such a possibility does not constitute a hazard and can only cause damage to the impeller shown by a drop in pressure reported by gauge.



THE PUMP MUST NEVER RUN DRY

P6 - 3-WAY LEVER TAP

It is mounted on the centrifugal pump (P4) and is connected to the body of the filter (P8). When the tap’s lever is set in position:

a. WORK (Vertically, downwards)

The mixture is sent both to the filter (P7) and the tank (P6) through the pipelines (T2) and (T9), for the hydraulic agitation of the mixture. In this position, by opening the distributor (P9) (or E9), the mixture is sent to the sprayhead.



TREATMENTS MUST BE CARRIED OUT ONLY WITH THE TAP IN THIS POSITION.

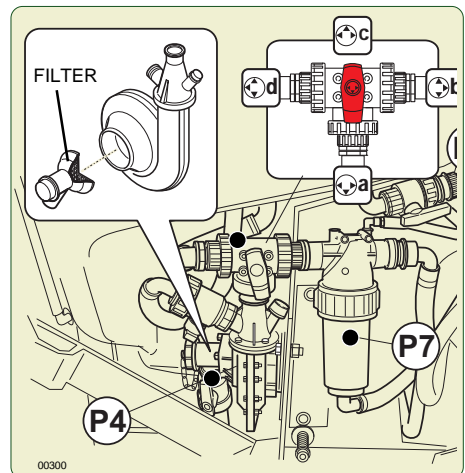

Furthermore, by opening the handle tap (P12) of the dust powder mixer, with manual distributor (P9) or electrical distributor (E9) closed, it is possible to carry out the product mixing. A different momentary positioning of the lever is required at times, but only for certain operations that will be specified from time to time.

b. POWDERS' MIXING (Horizontally, rightwards)



Only the mixing of powder products is to be carried out in this position

The pump delivery is sent to the filter (P7). By opening the faucet (P12) and closing the distributor (P9 or E9), the delivery is sent to the mixer (P13) of the main pipe union.



The flow to the tank is closed, through the regulator (P5) and (T2) and the delivery towards the distribution device (sprayhead), therefore there is no delivery and it is not possible to do the treatments. The hydraulic agitation is partially maintained through the additional agitation pipeline (T9)

c. DETACHMENT/REATTACHMENT OF THE FILLING PIPE (Vertically, upwards)

The flows towards piping (T2) is interrupted.



This is to be positioned AT THE END of the tank's filling operation, before disconnecting the filling up piping. (TR) (accessory). NEVER OPERATE THE SPRAYER WITH TAP (P6) IN THIS POSITION.

d. FILTER MAINTENANCE (Horizontally, leftwards)

The flow to piping (T2) is open. The capacity flow towards filter (P7) and to the feeding circuit is closed. This allows the cleaning of filter (P7) even with a full tank; check that tap (P12) is closed.

P5. MANUAL PRESSURE REGULATOR

It is mounted on the tank and is connected to tap (P6) through piping T2. It regulates the operating pressure by controlling the return flow to the tank.

- **By closing it: it REDUCES the return flow to the tank** and therefore, the agitation of the mixture, and it increases the operating pressure and capacity flow to the head (rotate the handle clockwise).
- **By opening it: it INCREASES the return flow to the tank** and therefore, the agitation of the mixture, while reducing the operating pressure and capacity flow to the head (rotate the handle anti-clockwise).

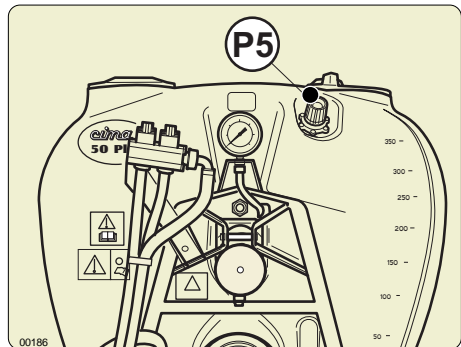

E5. PRESSURE CONTROL ELECTRO-VALVE

(for the version where foreseen)

It is connected to the delivery filter (P6) and to the tank (P1), through the pipe (T2). It adjusts the operating pressure checking the backflow into the tank.

In the E.P.A. versions, the pressure regulation is **automatically** controlled by the electronic control unit (see specific manual).

P3. LEVER TAP FOR EXCLUSION OF ADDITIONAL HYDRAULIC AGITATION

(for the version where foreseen)

Mounted on the pump (P4) it is connected to the tank (P1) through the pipe (T9).

- a = OPEN** when the control lever is parallel to the tap's body
- c = CLOSED** when the lever is perpendicular to the tap.



It must normally remain in the open position. The tap must **ONLY** be closed to wash the spray-line circuit (see point 10.4) and to completed the operation, it must be reopened.

P14. ONE-WAY VALVE (NON-RETURN)

It is positioned on the pipeline (T9) at the entrance in the tank and it prevents, with the pump still, the reflux of the mixture to the pump itself and the emptying of the tank in case of maintenance interventions on the pump with pesticide mixture in the tank.

P7. FILTER

The filter has a filtering capacity of 250 l/min., with a 50 mesh cartridge.

The dirty cartridge causes the operating pressure chute. This inconvenient is signalled by the pressure gauge (P8).

Mounted on the feeding pipe, it only filters the delivery flow to the heads, by sensibly reducing the possibility for the cartridge to get obstructed. On the body of the filter there is an attack, with internal thread 1/4", to make a functional test of the gauge (P8).

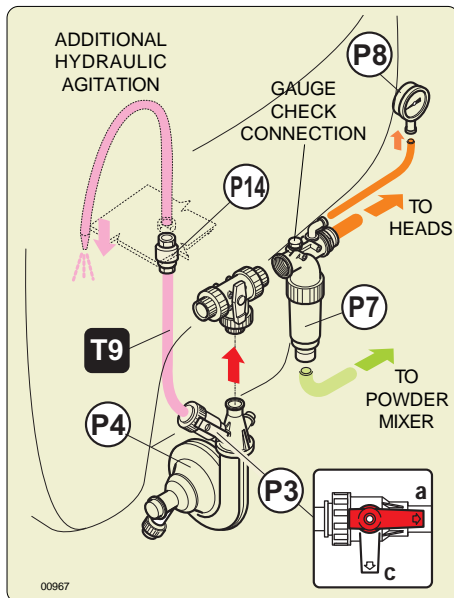
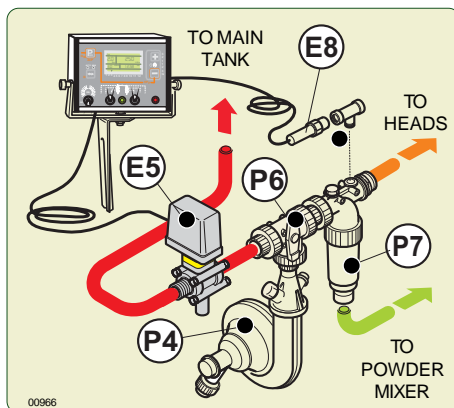

P8. GAUGE

Glycerine-dipped, with dial from 0 to 6 Kg/cm² (atmosphere) – adjustments scale of 1/10 of atmosphere, 100 mm diameter.



Set the working pressure, by acting on the regulator hand grip (P8), keeping the (P9) or (E9) opened.

E8. TRANSDUCER OF THE DELIVERY PRESSURE

(E.P.A. versions)

In the E.P.A. versions, the pressure transducer is connected to the delivery control computer. (see the specific manual).

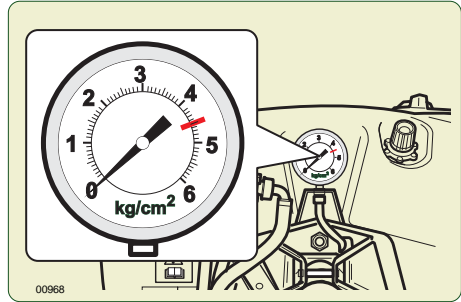

P12. POWDER MIXER LEVER TAP

(For versions in which his envisaged)

Positioned on the pipe (T6), between the filter (P7) and the mixer (P13) in corrispondenza dell'ingresso della tubazione nel serbatoio principale (P1); it can assume the following positions:

a - Open

From the centrifugal pump (P4), the liquid is sent to the mixer (P13) positioned on the bottom of the cup-like filter of the main filler (BP).

c - Closed

P13. POWDER MIXER

It makes the mixing of the powdery products during the filling of the tank. It is mounted on the basket filter of the main filler (BP) and it is connected to the pump (P4) by the pipe (T6). That device consists of a fine mesh-nylon basket, which is placed inside the tank main filler (BP). The basket is equipped with a mushroom outlet, through which the filling water coming from the pump (P4) streams out. Thanks to that system, the powder products contained inside the basket get more gradually dissolved, and the building of crumbs and thickenings can be avoided.

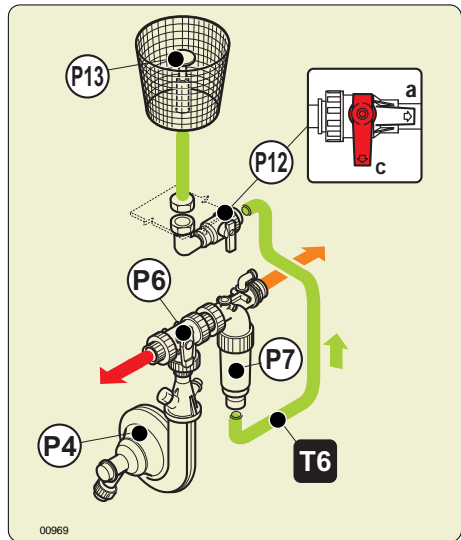

P25. SELF-CLEANING FILTER FAUCET (for the version where foreseen)

It is placed in the lower part of the filter body (P7) and connects it, through the pipeline (T6), to the tank.

a - Open, filter cleaning

The mixture coming from the pump (P4) passes through the filter (P7) removing residual product that can cause the obstruction of the filter.

c - Closed, treatment

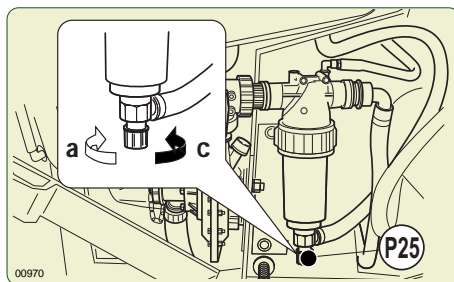

P9. MANUAL DISTRIBUTOR WITH 2 LEVER-OPERATED TAPS

It connects the feeding pipe (T4) to the distribution piping (T5). It remote-controls the closing and opening of the pulverising. The mount bracket, supplied with the machine, must be secured to the tractor within the driver's reach. When the machine is not hitched to the tractor, it must be placed on the forward part of the sprayer's frame.

Each tap permits the spraying from a single side of the head: to the right and to the left respectively. They are **open** when the levers are set in the **vertical** position.

They are **closed** when the levers are **horizontal**.

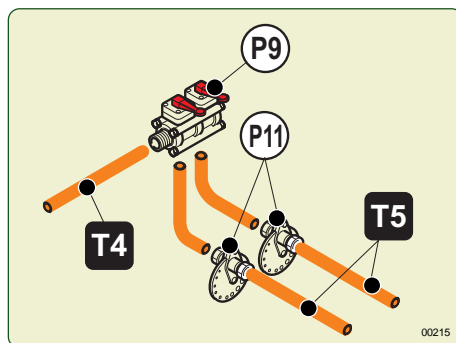

E9. ELECTRICAL DISTRIBUTOR WITH TWO SOLENOID VALVES

(for the version where foreseen)

It is connected with the feeding pipe (T4), the distribution pipes (T5) and the electrical unit (E10), which is fastened on the tractor. The solenoid valves open and close themselves, according with the action carried out on the electrical control unit switches.

In the E.P.A. versions, the controls of the cross section solenoid valves are situated on the electronic control unit (see specific manual).

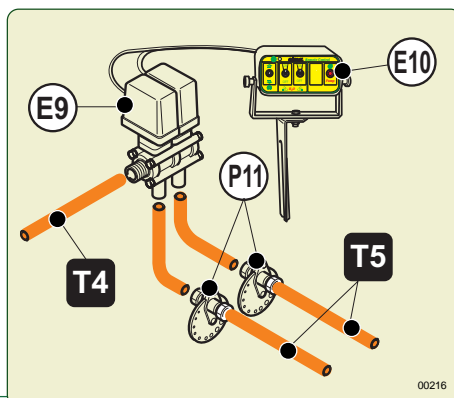

E10. CONTROL UNIT (for versions provided with)

It is electrically connected to the distributor with 2 motorised solenoid valves (E9) and to the main socket of the tractor (Lighter tap).

The 2 lever switches, controlling the solenoid valves (E9), have to be set to "ON" for opening and to "OFF" for closing. The control unit is equipped with a bayonet support to be inserted in the bracket provided. This must be mounted on the tractor, within the driver's reach. When the machine isn't hitched to the tractor, it must be placed in the position foreseen on the forward part of the machine frame.

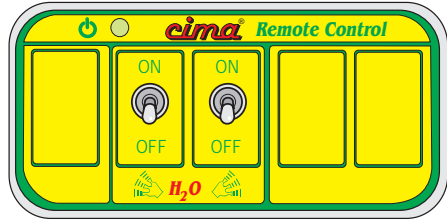

P11. CALIBRATION DISC (Patent N° 23238)

It selects the flow rates necessary to the treatment and is mounted on the distribution devices. It is made up of 2 flanges, held in position by two butterfly nuts, locking a disc with calibrated holes numbered from 1 to 15. A groove on the edge of the disc allows the exact positioning of the hole to be utilised. Its number must appear in the flange's semi-circular seat. The rotation of the disc is obtained by loosening the butterfly nuts by a few turns. After the operation is done, screw back carefully.



Any faulty sealing condition of the hydraulic circuit causes an intermittent issuing of the sprayed material. It is necessary to carefully check the efficiency of the sealers and clamps, the tightening of the ring nuts and fittings and the good working condition of the piping.

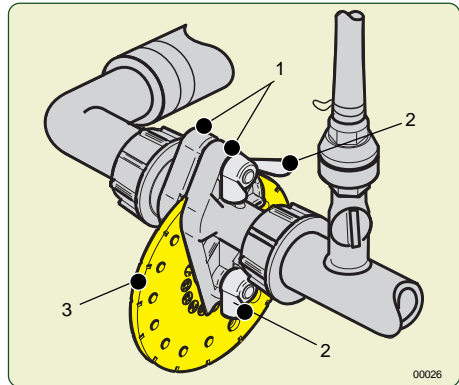

LEGEND

- 1 - UNION FLANGES
- 2 - LOCKING NUT
- 3 - ROTATING DISC WITH CALIBRATED HOLES

P17. SPRAY-LINE RINSING TANK

(for versions provided with)

The tank, 45 liters capacity, is made of polyethylene and is supplied with a filler and pipelines connecting to the machine hydraulic circuit.



P15 - 3-WAY PLANT-WASHING TAP (For the models on which it is foreseen)

The cock (P15) is joined to the tank (P1) and, on one side, to the plant-washing tank (P17) through pipe (T7), on the other side it is joined to the centrifugal pump (P4) through the suction pipe (T1).

The unit-washing circuit allows to wash the hydraulic circuit (with the exclusion of the tank), in every moment and independently on the tank load conditions, i.e., also with the mixture present inside the tank. When the tap (P15) is placed to position "b" the clean water for the unit washing is taken from the unit-washing tank (P17) by simultaneously excluding the suction from the main tank.

The 3-way cock lever can be positioned as here following specified:

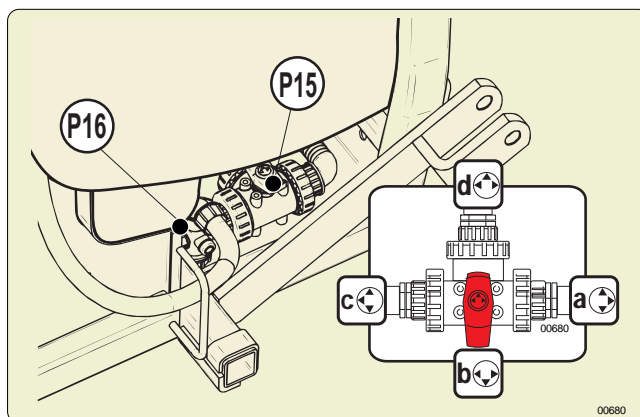

a – TREATMENT (WORK)

The liquid gets out from the tank (P1) and is sucked by the pump (P4); this is the **NORMAL** operating position, which is used in order to carry out the treatment and/or to keep the mixing on. The connection with washing tank **is closed**.

b – WASHING PROCESS

The fluid gets out from the unit-washing tank (P17) and is sucked by the pump (P4); that is the position which is used, in order to carry out the hydraulic circuit **WASHING**.



TO AVOID THE RETURN OF CLEAN WATER TO THE TANK, WITH CONSEQUENT DILUTION OF THE MIXTURE CONTAINED IN IT, CLOSE THE FAUCET (P3) AND COMPLETELY CLOSE THE REGULATOR by rotating the manual regulator handle (P5) clockwise or by turning the pressure up (keep the joystick on “+” for about 15 seconds for the versions with pressure regulation electrovalve), **DURING THE WASHING**.

c – EMPTYING OF THE TANK

In this position, the tank (P1) is emptied. **The union with the centrifugal pump is closed**. In order to empty the tank, the drain plug of the union tee (P16) must be removed.

d – COMPLETE DRAINAGE

In this position, it is possible to empty: the tank (P1), the pump (P4) and all the pipes of the hydraulic circuit. If the plant-washing tank is also filled, it is emptied too.

4.4 - TECHNICAL DATA

4.4.1 - Machines dimensions and weights

- with protection ring
- without distribution device
- without accessories

		Tank capacities (litres)		
		300	400	600
Plus 42	Total width (mm)	960	1120	-
	Total height (mm)	1160	1180	-
	Length (mm)	1380	1380	-
	Weight, empty (kg)	195	200	-
	Weight, full load (kg)	513	618	-
Plus 45	Total width (mm)	960	1120	-
	Total height (mm)	1160	1180	-
	Length (mm)	1380	1380	-
	Weight, empty (kg)	202	207	-
	Weight, full load (kg)	520	625	-
Plus 50	Total width (mm)	960	1120	1450
	Total height (mm)	1160	1180	1230
	Length (mm)	1450	1450	1450
	Weight, empty (kg)	225	230	244
	Weight, full load (kg)	543	648	862
Plus 55 55S 55E	Total width (mm)	-	1120	1450
	Total height (mm)	-	1180	1230
	Length (mm)	-	1480	1480
	Weight, empty (kg)	-	236	250
	Weight, full load (kg)	-	654	868

UNAPTO2

4.4.2 - Centrifugal pump CD32

Model C.I.M.A. CD32 - Grid/filter on suction - Drain plug - Filler for the connection of the filling pipe, with plug with chain.

Activated with trapezoid belt driven by the pulley mounted on the fan shaft.

Technical data printed on the body of the pump.

- Speed 4000 RPM Plus42
- Flow rate 120 litres/min. Plus42
- Speed 4250 RPM Plus 45-50-55S-E
- Flow rate 140 litres/min. Plus 45-50-55S-E
- Suction filter 7 mm
- Maximum pressure 4.5 Kg/cm²
- Power absorbed kW 2.5



The performance specified is obtained with the drive outlet (PTO) at 540 RPM
 For a good result of the treatments this condition **MUST ALWAYS BE OBSERVED** during the machine's operation. Utilisation is permitted with speed rates ranging between 500 and 620 RPM

5 COUPLING MODALITIES 5

5.1 - HITCHING TO THE TRACTOR



Check that the tractor’s “permissible carried weight” and the “rear overhang allowed” are compatible with the weight and dimensions of the fully loaded sprayer and complete with equipment mounted for the treatment (see Paragraphs “3.1” - “4.4.1” and the attached documentation).



The tractor’s power take-off (PTO), under all utilisation conditions, must provide a power exceeding that absorbed by the sprayer.



The hitching has to be carried out on a plane surface, after having checked that all the people not charged with the operation moved away, as well as the children and the animals possibly present.

Pairing suggested for tractors of at least	Type of mounted sprayer PLUS					
	42	45	50	55	55S	55E
CV	25	45	65	70	80	90
kW	18	33	48	52	58	66

UMAPT05

EXECUTION:

1. Loosen the chains of the lifter arms.
2. Start the tractor and take the lifter’s arms to the level of the machine’s pins.
3. **Stop the tractor and remove the key from the control panel.**
4. Insert the toggle joints on the machine’s pegs, locking them with the clip pins.
5. Hook the 3rd-point rod from the tractor to the machine and securing it with the peg and the clip pin.
6. Screw the rod to set it into tension.
7. Start the tractor and hoist the sprayer until the 2 PTO are the same height.
8. **Stop the tractor, remove the key from the control panel and make sure that no one approaches the hydraulic controls of the lifter.**
NEVER OPERATE OR STAND BENEATH THE MACHINE OR IN THE AREA THAT COULD BE INVOLVED IN ITS SUDDEN LOWERING.
9. By acting on the 3rd-point rod, vertically align the sprayer. **N.B.: block the 3rd-point rod with the specific lock ring.**
10. Block the coupling by tightening the chains of the hoister arms.



When the operation is completed the 2 drive outlets (PTO) must be positioned on the same axis, both in vertical and horizontal direction.

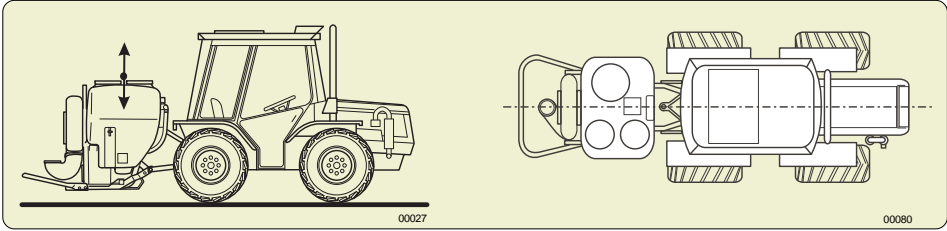

5.2 - MOUNTING THE CARDAN TRANSMISSION SHAFT



The mounting, disassembling or possible other interventions on the transmission shaft must be carried out with the engine switched off and with the starter key removed from the tractor's control panel.



USE TRANSMISSION SHAFTS WITH CE CERTIFICATION. OBSERVE THE REGULATIONS CONTAINED IN THE USE AND MAINTENANCE BOOK-LET PROVIDED BY THE SHAFT MANUFACTURER.



The cardan transmission shaft must work with the 2 COAXIAL drive outlets (PTO) or, should this not be possible, with the PARALLEL axles. In this case the angle of the joint MUST NOT EXCEED 15°.

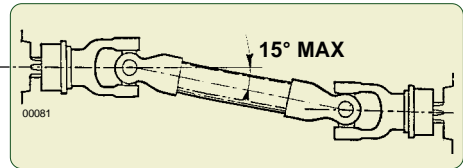

Definition of the length

Set the 2 drive outlets (PTO) perfectly on the same axis and measure the distance "D" between their grooves. Length "L" of the cardan transmission shaft (refer to the picture) to be deployed, measured between the 2 stopping pawls and with joint closed, must be 25÷40 mm lesser than distance "D".

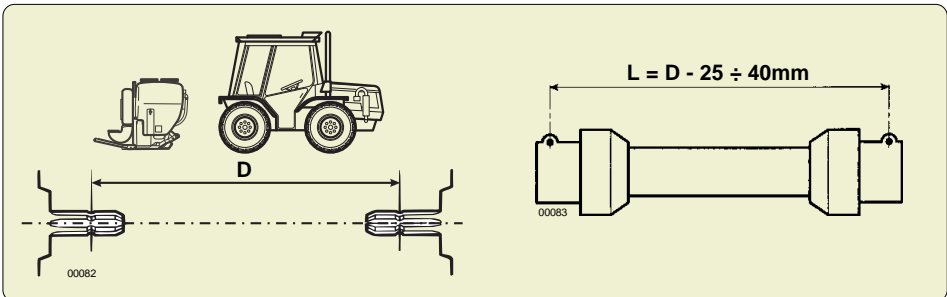

Using the cardan shaft too much short can cause the breach of it, with serious damages to the sprayer and/or to the tractor, and dangerous for the persons.



Using the cardan shaft too much long cause a push on the two PTO, that it can cause huge mechanical damages both to the tractor and to the sprayer.

5.3 - INSTALLATION OF REMOTE CONTROLS

5.3.1 - Manual 2-tap distributor - P9

- 1 - Mount the securing bracket on the tractor within the driver's reach (if this is not already present on the tractor).
- 2 - Insert the distributor's bayonet support in the securing bracket.
- 3 - Connect the feeding pipe (T4)
- 4 - Connect the distribution piping (T5) al circuito idraulico del dispositivo di distribuzione (testata) montato sulla macchina (seguire le istruzioni dello specifico libretto "uso-manutenzione" che lo accompagna).



Position the distribution piping (T5) and feed piping (T4) so as to avoid the risk of suffering damage or breakage during spraying. IT MAY BE NEEDED TO SHORTEN THE PIPES.

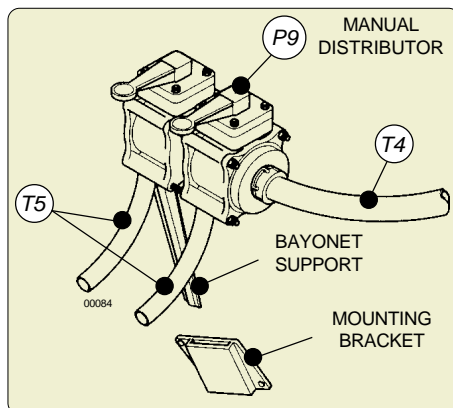

IN CASE OF A PIPE BURST:

- 1 - Stop the tractor and remove the key from the control panel.
- 2 - Close the 2 taps of distributor (P9).
- 3 - Move the 3-way cock (P6) lever to position "d"
- 4 - Repair or replace the broken pipes (for the elimination of these parts, please follow the current regulations).

5.3.2 - Electrical control panel - E10 (for versions provided with)

- 1 - Fix the fastening bracket near to the driver (if not already available on the tractor).
- 2 - Insert the bayonet support of the control panel in the securing clamp.
- 3 - Connect the distribution piping (T5) to the hydraulic circuit of the distribution device (head) mounted on the machine (follow the instructions of the specific "use and maintenance" book-let which is supplied with it).
- 4 - Connect the feeding pipe (T4) with the electrical distributor (E9).
- 5 - Connect the power supply cable (W1) plugging it in the socket of the tractor (cigar-lighter socket).



Position the electrical cables (W1) and (W2) in such a way as to avoid risking their being wrenched off during treatments. If necessary, use some securing clamps. A sudden interruption of power will lock the 2 solenoid valves of the electrical distributor (E9). Should this fault take place when they are in the open position, it is necessary to:

- Stop the tractor and remove the key from the control panel.
- Position tap (P6) on "d".
- Restore the electric current.

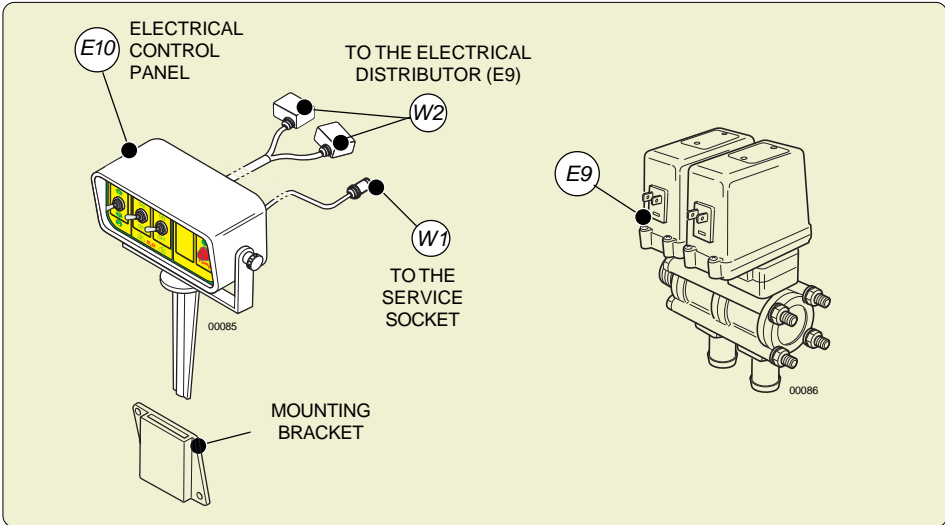

IN CASE OF A PIPE BURST:

- 1 - Stop the tractor and remove the key from the control panel.
- 2 - Close the electrovalves (E9), the switches on the control panel (E10) must be on OFF.
- 3 - Place the lever of the 3-way tap (P6) in position "d".
- 4 - Replace the broken pipe (for the elimination of these parts, please follow the current regulations).

5.3.3 - E.P.A. Control Unit



Act in a similar way as indicated for installing the electric control power plant (E10) (see Paragraph 5.3.2.)



Position the electric cables in such a way to prevent them from getting torn during the treatment.

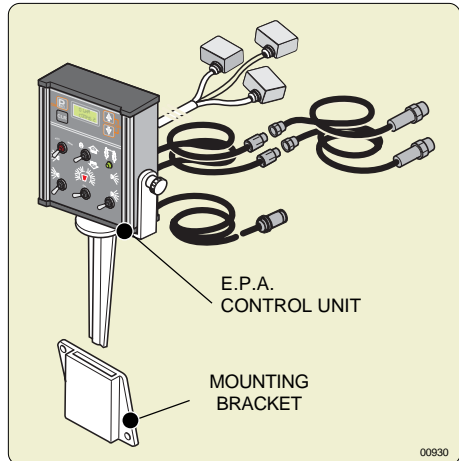

6 DISTRIBUTION DEVICES 6



Every distribution device is supplied with its own **USE AND MAINTENANCE** booklet that is, or will have to be, attached to this publication and will constitute one of its integral parts.

The "Distribution devices –Operatio and maintenance instructions" manual both shows and describes the wide range of the distribution devices (heads), to be employed on each sprayer in order to assure a perfect covering, always answering to the real requirements of the culture to be treated. All the heads can be very easily oriented and regulated, so to optimise the necessary covering.

Simple heads

DELIVERY ON THE TWO SIDES

00482

00117 00111

DELIVERY ON ONLY ONE SIDE

00493

00494 00495

Combined heads

DELIVERY ON THE TWO SIDES

00163

00122

DELIVERY ON ONLY ONE SIDE

00508

00509

6.1 - POSITIONING OF FAN CASING

The fan's air outlet must be positioned according to the distribution device to be mounted and the modality in which it is to be utilised. The operation is possible since the fan's casing can be rotated on its axis up to 360°.

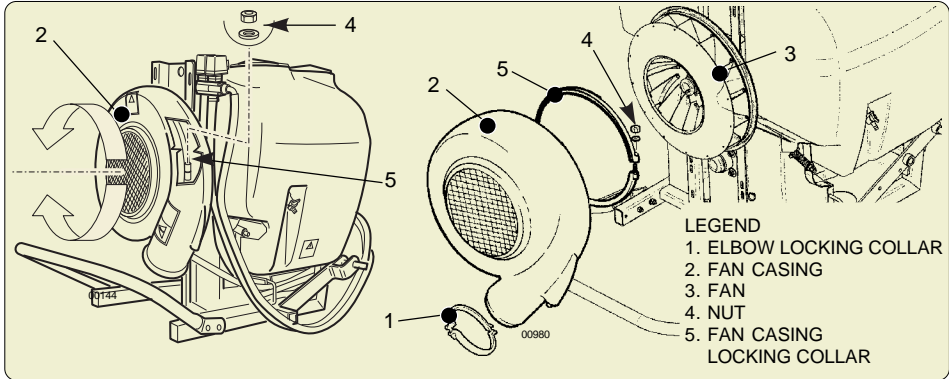

POSITIONING OF THE CASING:

1. Position the sprayer on the ground if it is mounted on the tractor.



Switch off the tractor and remove the key from the control panel.

2. By undoing the locking nut, loosen the collar which supports and locks the casing to the frame, located opposite the suction grill.
3. Rotate the casing and place the outlet in the position necessary for assembling (indications contained in the use and maintenance booklet of the distribution device).
4. After this has been done fasten the collar again.

6.2 - ELBOW FITTINGS OF DISTRIBUTION DEVICES

The elbow fittings support and connect the distribution devices to the fan casing. Several types are assembled on available standard machines, while others, must be supplied together with the distribution device.

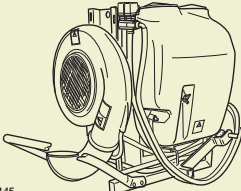
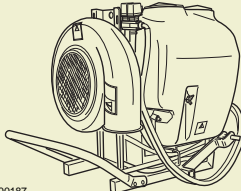
PLUSERIES	42 - 45 - 50	55 - 55S - 55E
STANDARD BASIC MODELS		
SPRAYER PROVIDED	WITH 180° ELBOW	WITHOUT ELBOW



In the "Distribution Heads - Operation and maintenance instruction" the type of elbow necessary for the connection is specified together with the assembling instructions.

7.1 - FILLER PIPE

The pipe is provided with a coupling elbow fitting and with a bottom-drawing valve. This is used for the filling of the tank.

It must be screwed into place on pump (P4) instead of the chain-held stopper.



The connection is **ALWAYS** to be done with the faucet (P2) closed (or P15 in position "c") and the faucet (P6) in position "c."



Before making use of it, it is necessary to check the operation and the proper sealing of the bottom-drawing valve, by pouring water into the pipe.

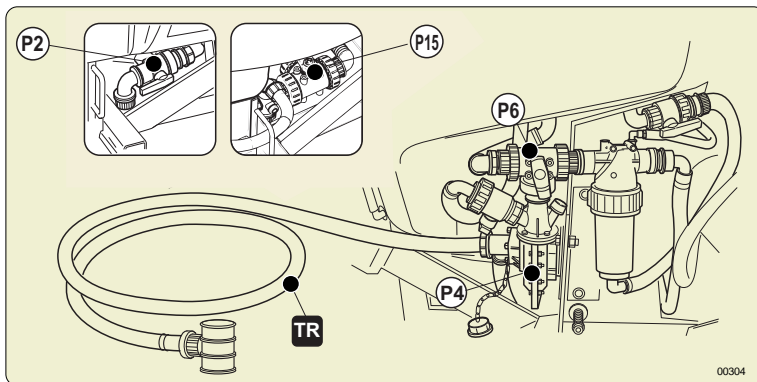

7.2 - PAIR OF WHEELS

The wheels thread can be adapted to that of the tractor.



MOUNT THE WHEELS AFTER HAVING HITCHED THE MACHINE TO THE THREE-POINT LINKAGE. DISMANTLE THE WHEELS BEFORE UNHITCHING THE MACHINE FROM THE THREE-POINT LINKAGE.

EXECUTION:

1. Hitch the machine to the tractor and lift it to a height at which the wheels can be mounted.



Stop the tractor, remove the key from the control panel and ensure that no one operates the three-point linkage's hydraulic controls. **AVOID OPERATING AND STANDING BENEATH THE MACHINE OR WITHIN THE AREA THAT MIGHT BE INVOLVED IN ITS SUDDEN LOWERING.**

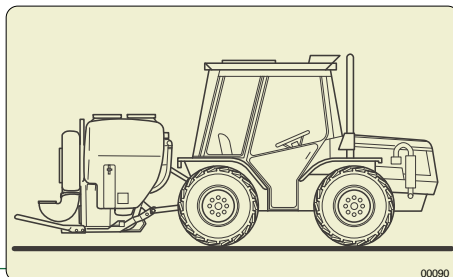

3. Insert the wheels' axle shafts into the machine's axle.
4. Adapt the wheels' track to that of the tractor.
5. Lock the axle shafts by means of the axle screws.
6. Start the tractor and keep the sprayer lifted during the transfers, lowering it to carry out the treatment.



THE SPRAYER MUST BE LIFTED AT EVERY DIRECTION CHANGE MAKING SURE THAT THE WHEELS ARE NOT RESTING ON THE GROUND.

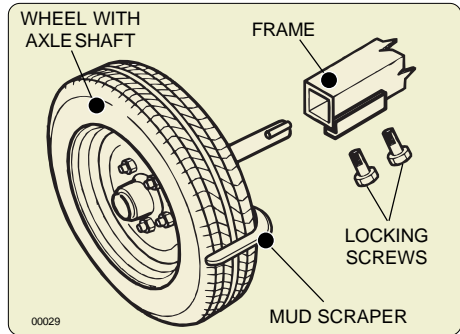

	Type of mounted sprayer PLUS					
	42	45	50	55	55S	55E
Wheel dimension	135/80 - R13 -70T			175/70-R13-82T		
Wheel pressure (atm)	2,7			2,7		
Wheel weight, with axles (kg)	40			44		

UNAPPT07



The utilisation of **NON ORIGINAL** pairs of wheels not equipped with mud scrapers will nullify the machine's warranty.



The operating pressure of the tyres is indicated on the decal placed on the rim of each wheel.

7.3 - SWIVELLING DEVICE

It is an accessory used to modify the direction of the spraying during the use of the sprayer; it can be used only with the distribution devices with delivery on the one side.

There is two type of swivelling device: manual controlled or electrical with remote control panel.



All indications and instructions are provided in the "Distribution heads - Operation and maintenance instruction" booklet of the distribution devices with which it can be used.

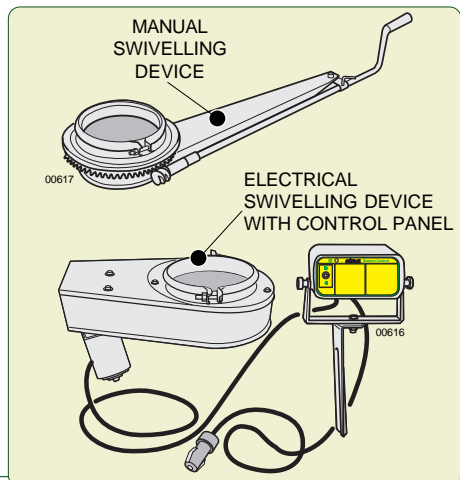

7.4 - E.P.A. Kit - DELIVERY PROPORTIONAL ADVANCEMENT

(for the version where foreseen)

The computerized E.P.A. system executes the monitoring of the distribution parameters for the active automatic control of the distribution proportional to the feed.

Through the constant takeover of the feed speed and the range of the product it is able to regulate the pressure continuously to keep the quantity of distributed product constant in relation to the treated surface.

The Kit is available in two versions:

- Version "Teejet® 76AB";
- Version "Teejet® 844AB."

Both versions are constituted from:

1. Magnetic induction proximity sensor (speed survey);
2. Pressure transducer (pressure survey);
3. Motorized electric valve (pressure regulation);
4. Computerized unit;
5. Dedicated printer ("Teejet® 844AB" version only).

For further information refer to the specific handbook.

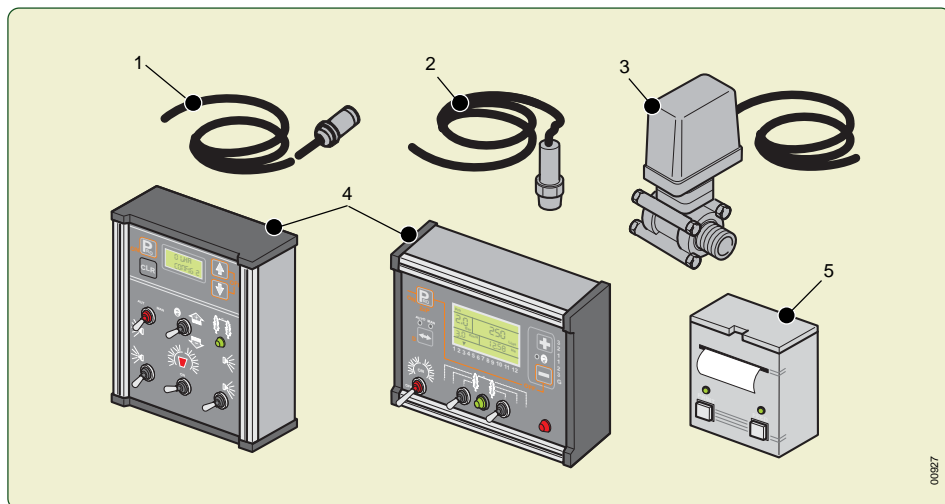

FILLING MUST BE CARRIED OUT WITH THE MACHINE ON A FLAT SURFACE. ON THE SITE BEFORE THE OPERATION, THE DOSES OR THE MIXTURES TO BE POURED INTO THE TANK MUST BE PREDISPOSED.





IT IS NECESSARY TO ALWAYS MAKE USE OF PERSONAL PROTECTION.

8.1 - FOREWORD - USE OF THE FAN DISENGAGEMENT

(for the version where foreseen)

8.1.a Disengagement of the fan

EXECUTION:

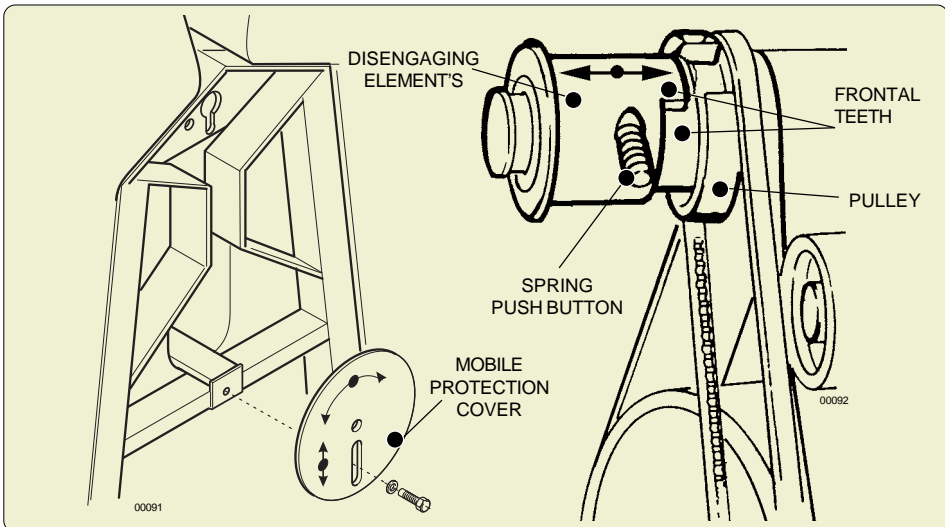

1. Take the sprayer to the area in which it is to be filled and rest it on the ground.
2.   Stop the tractor, remove the key from the control panel and check that the fan has stopped.
3. Undo the mobile protection cap's fixing screw and rotate it so as to access the disengagement tunnel.



4. Fully press the spring push button and pull the front element until it springs out. The body disengaged from the retaining joint must turn freely: the pump will operate and the fan will thus be excluded.
5. Reposition the mobile protection cover and fasten the locking screw properly.
6. Start the tractor, lift the sprayer to position the universal joint shaft and carry out the filling operation.

8.1.b Fan engagement to perform the treatment

EXECUTION:

1. Disengage the power take off (PTO) and rest the machine on the ground.
2.   **Stop the tractor, remove the key from the control panel and check that the fan is stopped.**
3. Undo the mobile protection cap's fixing screw and rotate it so as to access the disengagement tunnel.
4. Fully press the spring push button, push the front body forward, if necessary, turning it to the right or left, until the frontal teeth of the joint engage the corresponding teeth of the pulley; at the same time, the spring push button must return to the outward position. This way, the body is again integrated with the pulley, thus transmitting the movement to the fan.
5. Reposition the mobile protection cover and suitably tighten the securing screw.
6. Start the tractor and lift the sprayer to position the universal joint shaft.

8.2 - FILLING THROUGH POURING FROM THE TOP



For this type of filling, use the supplementary filler (BS) located in the upper right-hand side of the tank, towards the front of the sprayer (opposite the filler of the hand washing tank).

THE INLET OF THE FILLER PIPING MUST NEVER COME INTO CONTACT WITH THE ANTI-PARASITIC MIXTURE: IT MUST ALWAYS BE KEPT AT A SAFE HEIGHT ABOVE THE TANK FILLER AND MUST BE EQUIPPED WITH A NON-RETURN VALVE.



THE PUMP MUST NEVER RUN DRY

EXECUTION:

1. Disengage the fan (for the version where foreseen): see point 8.1.a.
 2. Close the taps of the 2-way distributor:
 - a. if manual (P9), set the levers in the horizontal position;
 - b. if electrical, position the latch switches (E10).on "OFF"
 3. Check that the following cocks
 - P2 (o P15): is open (lever on "a");
 - P6: is on working position (lever on "a");
 - P12 (for the version where foreseen): closed cock (lever on "c").
 - P6, pressure regulator: is completely open for the unit's first use, or on the already selected position for the outstanding treatment or for the previous one.
 4. Pour water in the tank to about 1/3 capacity through the supplementary filler BS.
- 5a. **FILLING WITH POWDER PRODUCTS BY UTILISING THE MIXER** (for which is foreseen)
- 5a1. Pour the dose of powder into the cup-like filter through the main filler (BP).
 - 5a2. Close the tank's main filler (BP).
 - 5a3. Open the tap (P12) (lever on "a").
 - 5a4. Set the lever of tap (P6) to the "b" position.
 - 5a5. Engage the Power Takeoff and set it up to a running rate of **at least 500 RPM**.
 - 5a6. Complete the filling with water and close the lid of the secondary filler (BS).



Use ONLY the PTO at 540 rpm. Engage the PTO with the engine of the tractor at low speed and with maximum modularity, obtaining soft and progressive graft and avoiding abrupt starts of the cardan shaft.

- 5a7. Close the cock (P12) (lever on "c").
- 5a8. Put the three-way faucet (P6) in work position (the lever on "a").
- 5b. **FILLING WITH MEDICINAL MIXTURES OR LIQUID PRODUCTS**
- 5b1. Pour the medicinal mixture envisaged for every loading (together with the water possibly used for the washing of product canisters and of the tools used in the preparation) into the main filler (BP).
- 5b2. Close the main filler (BP) of the tank.
- 5b3. Engage the drive outlet (PTO) and take it to a speed of at least 500 RPM
- 5b4. Complete the filling with water and close the lid of the secondary filler (BS)
6. Move to the treatment place, keeping the Power Takeoff running rate at a minimum value of 500 r.p.m. during all the way.

FILLING DIRECTLY IN THE TREATMENT AREA:

7. Disengage the drive outlet (PTO) and rest the sprayer on the ground.



Stop the tractor and remove the key from the control panel.

8. Ensure that the fan is stopped. Engage the fan to the servo amplifier as indicated at point 8.1, then re-close the mobile protection cover.



Tighten the protection-securing screw properly.

9. Start the tractor.
10. Lift the unit. Engage the Power Takeoff and set it up to a running rate of at least 500 r.p.m., **in order to carry out a further agitation.**



Use ONLY the PTO at 540 rpm. Engage the PTO with the engine of the tractor at low speed and with maximum modularity, obtaining soft and progressive graft and avoiding abrupt starts of the cardan shaft.



12. Regulate the operating pressure, by acting on the pressure regulator (P5) (or electric E5) with the distributor, hand (P9) or electric (E9), open (DISTRIBUTION).
13. CARRY OUT THE TREATMENT (See the paragraph 11.3).

8.3 - FILLING WITH THE SPECIFIC PIPE

(optional device)



USE ONLY IF CONCURRED FROM THE LAWS OF THE COUNTRY WHERE THE SPRAYER IS USED. Before utilisation, check the operation and proper sealing of the bottom-drawing valve by pouring water in the piping.



THE PUMP MUST NEVER RUN DRY.

EXECUTION:

1. Disengage the fan, see point 8.1.a.
2. Close the 2-way distributor:
 - a. se manual (P9), set the levers in the horizontal position;
 - b. if electrical, position the latch switches (E10) on "OFF".
3. Check that:
 - P6: is open (lever on "a");
 - P12: is closed (lever on "c");

- P5, pressure regulator: is completely open for the unit's first use, or on the already selected position for the outstanding treatment or for the previous one.
- 4. Close the faucets (P2) (or P15) by positioning the lever on "c."
- 5. Connect the filler piping to the pump.
- 6. Re-open the faucets (P2) (o P15) (lever on "a").
- 7. Immerse the filter with the bottom-drawing valve in the water to be loaded.



The filter must always be below the level of the water to be loaded. The piping must never be above the pump's suction point and must never be excessively bent in the vertical direction.

- 8. Through the secondary filler BS, pour approximately 15~20 litres of water into the tank: the quantity must be sufficient to FILL the piping and ACTIVATE the pump to start the recycle.
- 9. Activate the power take off (PTO) and take it to a rotation speed of **at least 500 RPM**.



Use ONLY the PTO at 540 rpm. Engage the PTO with the engine of the tractor at low speed and with maximum modularity, obtaining soft and progressive graft and avoiding abrupt starts of the cardan shaft.



- 10. When the pump has started the circulation of the water poured, close tap (P2) (o P15) (lever on "c") to start up the filling.

11a. **WITH MEDICINAL MIXTURES OR LIQUID PRODUCTS (WITHOUT MIXER DEVICE).**

- 11a1 Pour the mixture of medicinal envisaged through the main filler (BP), together with the water used to wash the canister of product and the tools used in the preparation.
- 11a2. Close the main filler (BP) of the tank.
- 11a3. After completing the filling, disengage the PTO
- 11a4. Close the tap (P6) setting the lever in position "c".
- 11a5. Disconnect the filler piping and replace the stopper on the pump.
- 11a6. Open the faucet (P2) (or p15) by putting the lever on position "a"
- 11a7. Open the tap (P6) setting the lever in position "a"

11b. **WITH POWDER PRODUCTS: UTILISING THE MIXTURE DEVICE**

- 11b1. Pour the dose of medicinal in powder form foreseen for each loading into the main filler (BP) of the tank.
- 11b2. Close the main filler (BP) of the tank.
- 11b3. Open the cock (P12) (lever on "a").
- 11b4. Wait for the filling to be completed.
- 11b5. Close the cock (P12) (lever on "c").
- 11b6. Disengage the power take off (PTO).
- 11b7. Close the faucet (P6) (lever on "c")
- 11b8. Disconnect the filler piping and replace the stopper on the pump.
- 11b9. Open the faucet (P2) (or p15) by putting the lever on position "a"
- 11b10. Open the tap (P6) setting the lever in position "a"
- 12. Engage the Power Takeoff and move to the treatment place, keeping the Power Takeoff running rate **at least 500 RPM during all the way.**

IN THE AREA OF THE TREATMENT

- 13. Disengage the power take off (PTO) and rest the machine on the ground.



- 14. **STOP THE TRACTOR AND REMOVE THE KEY FROM THE CONTROL PANEL.**

- 15. Make sure that the fan is stopped. Hook the fan to the servo amplifier as indicated at point 8.1.b.
- 16. Start the tractor, always observing the safety norms.

17. Lift the unit. Engage the Power Takeoff and set it up to a running rate of at least 500 r.p.m., **in order to carry out a further agitation.**
18. CARRY OUT THE TREATMENT (See the paragraph 10.3).

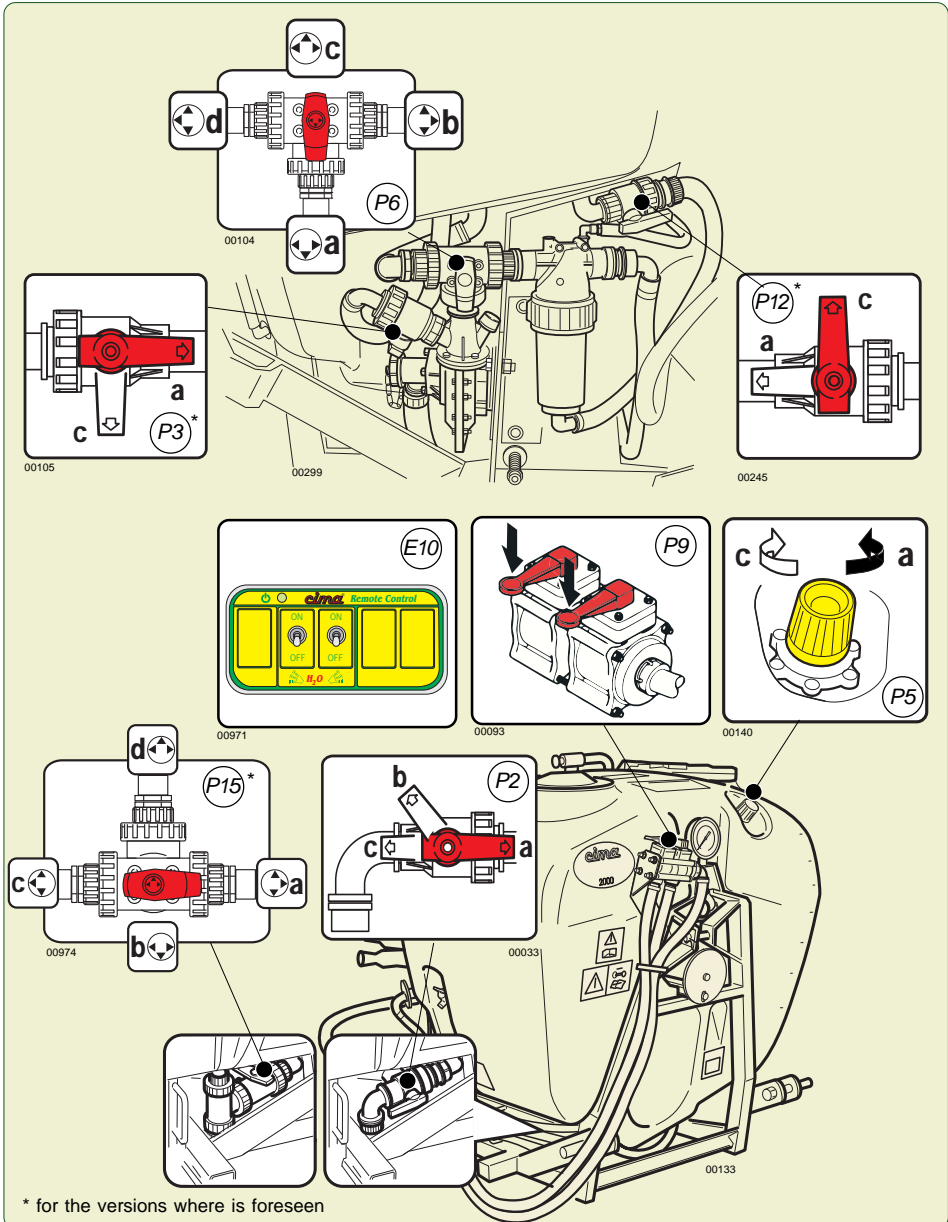

* for the versions where is foreseen

The **hydraulic** and the **pneumatic** circuits mounted inside the tank, allow to realize a **double agitation system**: with the pump water and with the fan air, **at the same time**. The pneumatic circuit can be excluded, when the products used have a quite strong foaming effect, by closing the piston cock, mounted over the tank. When that cock is opened again, check that the air outlet holes aren't obstructed.



It is advised however to also use always the pneumatic agitator, adding to the mixture, if necessary, a antifoam product.



Before starting the treatment it is essential to agitate the mixture in the tank, recirculating it completely for as long as it takes to make it homogeneous.



The piston cock mounted over the tank have to be open. This operation is of main importance, in order to get a uniform distribution of the active principle on the whole vegetative surface to be treated.

Should the activity need to be interrupted during a treatment with the sprayer, keep the agitator activated until the treatment is resumed. Should this be stopped and deferred to a later stage, the mixture that has remained in the tank must be **agitated again** properly.

THE MIXTURE AGITATION HAS TO BE CARRIED OUT WITH THE POWER TAKEOFF RUNNING AT A RATE OF AT LEAST 500 r.p.m..



Before using the atomizer fill the circuit-washer tank (if provided) and the hand-washer tank with clean water.

10.1 - OPERAZIONI PRELIMINARI AL TRATTAMENTO

- The operator must:
 - a. Ascertain that the condition of the crops, the progress of the disease or the need for its prevention actually justify the treatment to be applied.
 - b. Be aware of the meteorological conditions forecast for all the time necessary for carrying out the treatment.
 - c. If possible, avoid carrying out the spraying in strong wind conditions or when one detects that the sprayed mixture disperses away from the target crop (drifting). It is advisable to suspend the treatment when the wind speed exceeds 3 m/s (10 km/hour). Should it be imperative to operate anyway, the following suggestions are made:
 - reduce the distance of the target from the spraying points, even if detrimental to the quality of the spraying
 - increase the dimension of the droplets, suitably adjusting the machine.

- d. Check that multiple-product mixtures be physically, chemically and biologically compatible amongst themselves; if need be, obtain the necessary information from the products' sales representative.
- e. Carefully calculate the exact quantity of the product necessary for the treatment and establish the volume of water to be used for the intervention.
- f. Check that the product is available in a quantity sufficient to complete the intervention.
- g. Read the product's utilisation instructions carefully, in order to ascertain the usage conditions, the correct dosage and the expiration dates.
- h. Make sure of the parameters necessary to the adjustments of the machine and determine the exact dose of product to be applied to every loading. **Follow the instructions of the publication titled "The low volume - Instructions for sprayers adjustment" as well as those contained in the use and maintenance book-let of the distribution device.**

10.2 - PREPARATORY OPERATIONS TO TREATMENT



THE FILLING MUST BE CARRIED OUT WITH THE MACHINE ON A FLAT SURFACE. BEFORE THE OPERATION, IN THE ALLOCATED AREA, THE DOSES OR MIXTURES TO BE POURED IN THE TANK MUST BE MADE READY.

Before starting the filling cycle, check:

- **FAN SHAFT SUPPORT OIL LEVEL.**
- **THAT THE CARTRIDGE AND THE DELIVERY FILTER (P7) ARE CLEAN;**
- **THE EFFICIENCY OF THE DISTRIBUTION DEVICE (HEAD);**

• **The operator must:**

- a. Wear adequate protective clothing and accessories such as overalls, waterproof suits, gloves, glasses and masks to shield him from contamination by inhalation or contact with the products handled.



- **Anti-dust masks don't offer any protection against toxic vapours.**
- **Avoid wearing loose clothes that might entangle with moving parts.**

- b. With the parameters defined during the preliminary operations, carry out the adjustments of the sprayer.
- c. Prepare the mixtures in a well ventilated area. When in the open, the presence of wind increases the danger of contamination.
- d. Precisely weigh the previously calculated doses of products to be mixed at every filling operation.
- e. Avoid handling products close to open flames, embers, incandescent bodies or in the presence of flammable substances.
- f. In order to obtain the correct volume dosage of agro-chemicals and fertiliser mixtures, the fertiliser must be first diluted.

- g. Wash and rinse the just emptied product containers with clean water – collect the washing water and pour it in the tank before carrying out the filling – place the empty packaging in the specific container or in the collection area.
- h. Wash the equipment and tools utilised in the preparation and place them in the chemical products storage area.
- i. **Always** leave the area assigned to the loading and preparation of the mixtures in such condition as to avoid **any** possibility of contamination to persons or animals or of pollution to the environment.
- l. If necessary, mark the field or the area of machine passes in order to provide a guide for the treatment and avoid missing or double-treating coverage areas.



- **AT THE END OF THE OPERATIONS NECESSARY FOR CARRYING OUT THE INTERVENTION, THE LOCATION-STORAGE AREAS MUST BE LEFT IN THE CONDITION REQUIRED FOR THE CARRYING OUT OF THEIR PREVENTION AND PROTECTION FUNCTIONS.**
- **BEFORE STARTING THE TRACTOR, KEEP AWAY PERSONS OR ANIMALS AND NEVER LEAVE IT UNATTENDED DURING THE PREPARATION OPERATION.**

10.3 - THE TREATMENT



IT IS ADVISABLE TO BEGIN TREATMENT AT THE HEADLANDS..



WHEN THE TREATMENT IS OVER, OR IF THE SAME HAS TO BE TEMPORARILY INTERRUPTED, ALWAYS LET THE FAN STILL OPERATE FOR APPROXIMATELY 30 SECONDS AFTER CUTTING-OUT THE POWER SUPPLY (EITHER MANUAL DISTRIBUTOR P10 OR ELECTRICAL DISTRIBUTOR E11), IN ORDER TO FULLY ELIMINATE THE PRODUCT MIXTURE FROM THE DISTRIBUTING DEVICES, SO PREVENTING ANY POSSIBLE ANOMALOUS DRIPPING FROM TAKING PLACE.

- **The operator must:**
 - a. Shake the mixture in the tank before starting the treatment, re-circulating it completely for as long as it takes to make it homogeneous.
 - b. Check the orientation of the distributors (hands, guns and/or fishtails) of the distribution device (sprayhead) in relation to the dimensions, the shape and the thickness of the vegetation to be treated.
 - c. Continue to shake the mixture until the treatment is resumed should the intervention momentarily be interrupted. If the utilisation is to be deferred, check that the filter cartridge is clean before resuming and **agitate the mixture** that has remained in the tank.
 - d. Ensure that the hand wash supplementary tank is filled with clean water after each filling operation.
 - e. Make use of individual protections identical to those envisaged for the preparation of mixtures if the tractor is not equipped with a pressurised cabin with aeration filters.
 - f. wash immediately all the elements that might have become contaminated during the treatment, promptly remove the polluted garments and **interrupt the work if these cannot be immediately replaced.**

- g. Keep to the preliminary operations already indicated (10.1.c), in case of wind conditions prevailing.
- h. Stop the engine, remove the key from the tractor's control panel and lower the hoist during stoppages.
- i. Pay particular attention to the treatment when close to boundaries and in proximity of dwellings, waterways, roads or public-usage paths.

10.4 - PROCEDURE TO WASH THE HYDRAULIC CIRCUIT (head-pump)



In case of machines equipped with unit-washing tank, every time it is necessary to suspend the treatment, it is possible to carry out the hydraulic circuit washing process, independently on the loading conditions, i.e., also when the tank is still containing some product mixture, so avoiding any possible clogging and assuring the perfect efficiency of the machine when the treatment is carried on again.

In case of prolonged idle periods, it is recommended to keep the mixture agitated (see Chapter 9).

In order to carry out the hydraulic circuit washing process, follow the instructions here specified:

- a. Close the faucet (P3) of exclusion of the additional agitation.
- b. Close the pressure regulator completely, by rotating the hand regulator (P5) handle clockwise or by turning the pressure up (keep the joystick on "+" for about 15 seconds) for the E.P.A. versions.
- c. Open the cock (P15), by setting it to position "b"; in that way the clean water contained inside the unit-washing tank is sucked by the pump (P4) and gets into the hydraulic circuit.
- d. Engage the PTO and take it to the correct distribution condition (540 rev/min - see paragraph 4.4.2)



CAUTION: THE PUMP MUST NEVER RUN DRY

- e. Open the taps of the manual distributor (P9) (or electrovalves E9 by taking the switches of the control electric switchboard on ON); make the atomizer work spraying on the piece of ground not treated yet, for a sufficient time to test the leakage of clean water from the sparyhead.

That easy procedure allows to eliminate every fuel mixture residual from all the hydraulic circuit components, so assuring in first place the accurate cleaning and the consequent efficiency of the calibrated holes of the rotary disc regulators.

- f. Disengage the PTO.
- g. Close the cock (P15) by taking it to the **A-WORK** position
- h. Open the faucet (P3) of exclusion of the additional agitation.

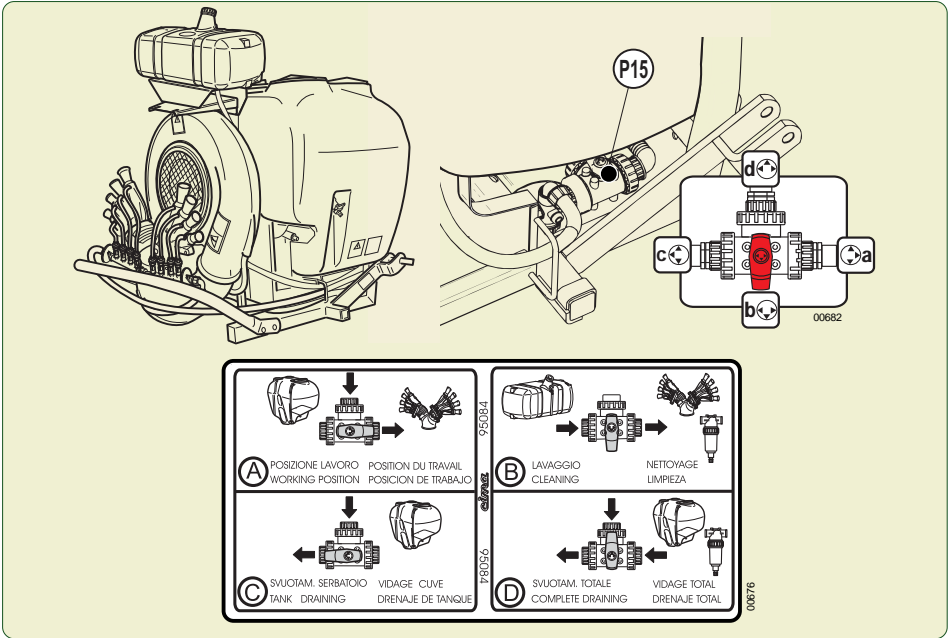

10.5 - END OF TREATMENT - STORAGE

10.5.1 - Daily

• **The operator must:**

- a. Wash the machine's exterior before cleaning out the hydraulic circuit. The operative sequence will permit the elimination of possible water residues from the fan casing and piping conveying the air flow to the heads.



The washing of the sprayer's exterior must be carried out in an area in which foul waters are collected in a disposal pit. DO NOT UTILISE HIGH-PRESSURE HYDRO-CLEANERS.

- b. Carry out the complete hydraulic circuit cleaning process, by washing the tank inside with a clean water jet; then, he has to operate the sprayer, by spraying the tank contents on the ground, in conformity with the antipollution directives in force in the country where the machine is employed: if necessary, repeat the whole procedure.
- c. Check the efficiency of the distribution device (head) and the cleaning of the pulverising points (diffusers), possibly replacing them if found to be damaged.
- d. Clean out the filter cartridge.
- e. Keep the machine in a ventilated place, sheltered from rain or sun: sunrays are the worst enemies — of plastic and rubber parts.

10.5.2 - End of seasonal cycle

- **The operator must:**

- a. Take the utmost care in carrying out the operations envisaged at the end of the daily treatments: the cleaning of the hydraulic circuit **and the main tank** must be done at least twice. Check that no product residues are left in any part of the circuit.
- b. Execute the necessary maintenance and lubrication operations (see paragraph 13.10), then let the atomizer operate for some minutes.



THE PUMP MUST NEVER RUN DRY.

- c. Completely drain the hydraulic circuit, paying a special attention to the centrifugal pump; in order to completely drain the pump, remove the draining plug, which is mounted on the pump itself.

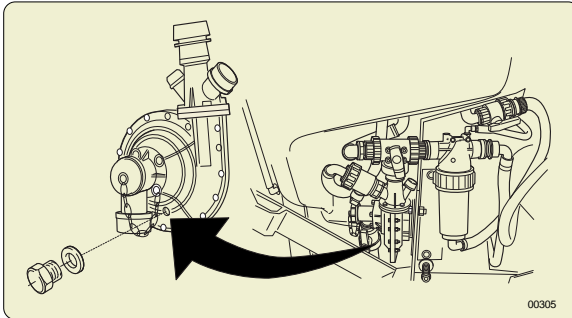

Avoid using anti-freeze solutions.

- d. Check the proper operation of all parts and of the machine structure. In case of faults being detected, request the intervention of one of our service points.
- e. Keep the machine in a well ventilated place, sheltered from rain, icing and direct sun rays.



The use of detergent products for the cleaning operations is allowed only in the observance of the regulations in force. For these, the operator must gather the relevant information from the specifically appointed bodies ruling on this subject.

11 TANK AND HYDRAULIC CIRCUIT DRAINING 11



- Stop the tractor and remove the key from the control panel.
- Wear suitable protective clothing and accessories in order to avoid contamination by contact or inhalation of the mixture.
- Carry out the discharging in a suitable and properly geared area for the collection of the washing liquid.

The operation is carried out through the drain plug (P2) (or P15) for machine equipped with unit-washing tank:

1. Unscrew the drain plug only when the tap's lever is in the "a" position. (Drain closed).
2. Turn the faucet (P2) lever in position "b". (Open exhaust).
3. After having carried out the draining, turn the faucet (P2) o (P15) lever to the position "a" (Draining closed) and screw again the draining plug.

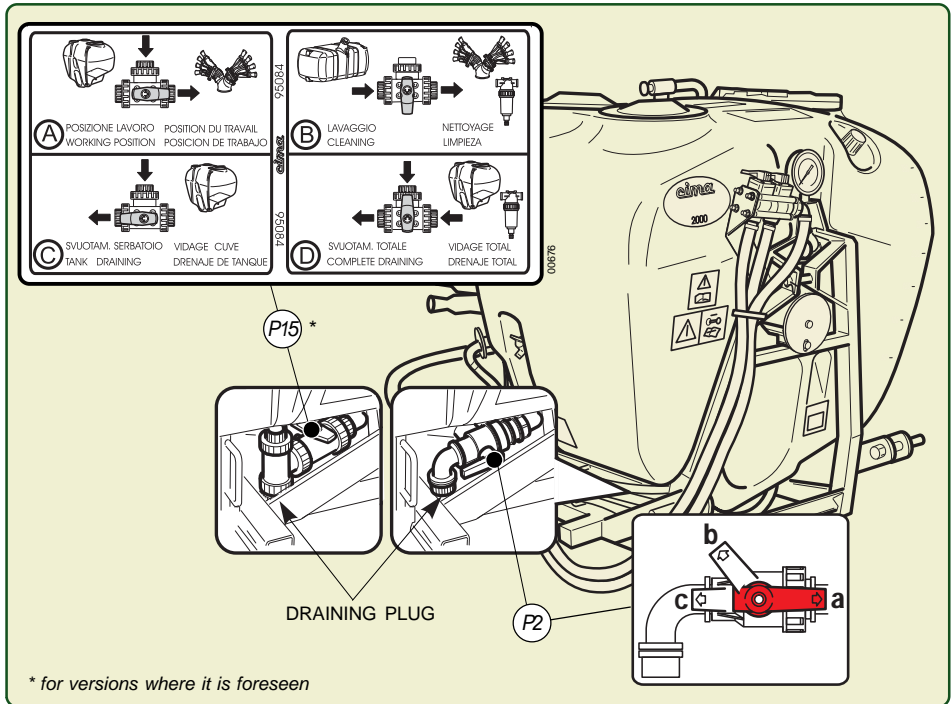

THE FOLLOWING ACTIONS ARE NOT ALLOWED:

- Transporting or lifting the sprayer with residual quantities of mixture in the tank for purposes differing from its destined usage.
- The transporting of people, animals or things.
- The trailing of vehicles or equipment.



Road transport must take place in the complete observance of road regulations in force in the Country where the machine is used.

- When the footprint of the sprayer exceeds that of the tractor, the specific notice sign for overhanging loads needs to be attached on the rear.
- It is necessary to replicate the tractor's number plate and tail lights when these are covered by the machine.

The operator is responsible for possible defaults due to the non observance of said regulations.

• Lifting and transport of the sprayer



Before carrying out any operation it is essential to verify that no mixture residues are left in the tank.

1. Check that the cables or chains used for the lifting are adequate for the weight to be lifted (machine – distribution devices - accessories).
2. Hook the machine through the specific support point indicated by the specific decal on the frame, checking all the parts involved in the operation.
3. Lift the machine, verifying that it is properly balanced, and, on those units equipped with either cables or hoisting chains, make sure that they DON'T get engaged with the plant-washing tank.

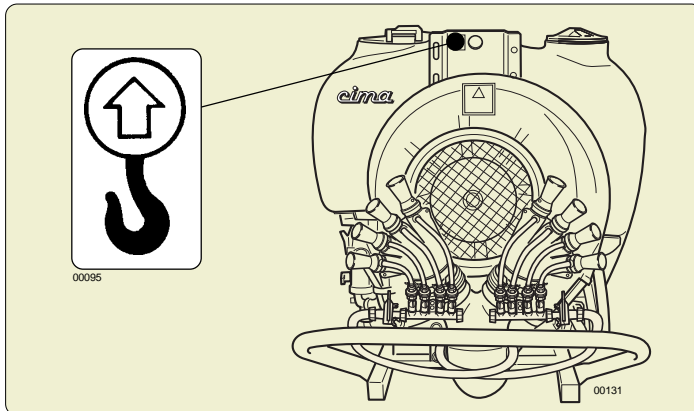

4. Position the sprayer on the transporting vehicle in perfectly stable conditions.
5. During transport the machine must be immobilised and fastened to the carrier by way of suitable strapping.

13 MAINTENANCE OPERATIONS 13



ALL OPERATIONS MUST BE CARRIED OUT WITH THE ENGINE SWITCHED OFF AND WITH THE IGNITION KEY REMOVED FROM THE CONTROL PANEL.

13.1 - LUBRICATION

Maintenance point	Action	Consumption material	Periodicity
Fan shaft bearings support	Check oil level	Oil SAE 90	8 hours
Fan belt-tensioner support	Greasing	Grease Type EP Classe NLGI 2	200 hours
Free wheel	Greasing	Grease Type EP Classe NLGI 2	200 hours
Fan shaft bearings support	Change oil	Oil SAE 90	Annuary

UMAP7011



Carefully clean the greasing nipples and the oil filler in order to avoid that, during lubrication, dirt might be introduced. In the case of intensive use of the machine, reduce the lubrication intervals.

00128

FAN BELT-TENSIONER SUPPORT

00085

FAN SHAFT BEARINGS SUPPORT

00298

00130

FREE WHEEL

00085

200

00085

8 h

CONTROLLARE
CHECK
CONTRÔLER
CONTROLAR

OIL

MAX
-
MIN

13.2 - FAN SHAFT SUPPORT OIL LEVEL CHECK

1. Unscrew and remove the oil filling plug with the dipstick.
2. Clean the dipstick and introduce it again.
3. Extract the dipstick and check the oil level, which has to be between the two minimum and maximum level notches of the dipstick itself.
Should it be necessary to top up the level, add some SAE 90 oil, up to reach the dipstick upper notch (MAX).
4. Introduce and screw the oil filling plug with the dipstick.

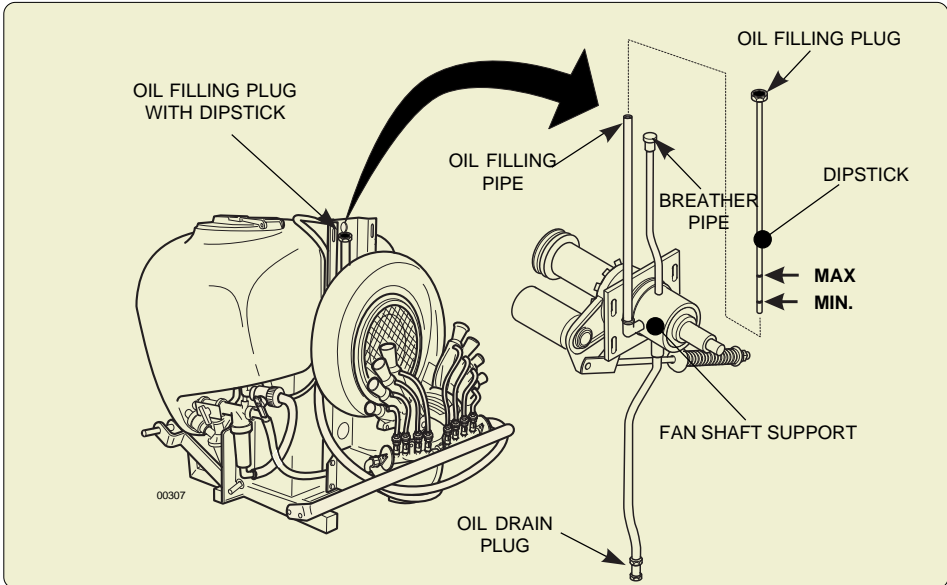

13.3 - FAN SHAFT SUPPORT OIL REPLACEMENT



Let the fan support oil replacement intervention be carried out at a C.I.M.A. customers' service centre, or observe the regulations in force for the disposal of the used oil.

1. Unscrew and remove the oil filling plug with the dipstick.
2. Remove the oil drain plug and let the oil completely flow out from the fan shaft support.
3. Check the oil drain plug and the relevant seal for integrity, replace them, if necessary, and close again the oil drain plug.
4. Through the filling pipe, pour a SAE 90 oil proper quantity, up to reach the MAX notch on the dipstick:
 - about 0,19 kg for the PLUS 42 and 45 models
 - about 0,24 kg for the PLUS 50 and 55 models.
5. Position again the plug with the dipstick and close the oil filling pipe.

13.4 - CLEANING OF FILTER'S CARTRIDGE

1. Set the lever of 3-way tap (P6) to the "d" position
2. Completely close the pressure regulator, by turning clockwise the handle of the manual regulator (P5) or by turning the pressure up (keep the joystick on "+" for about 15 seconds) if the atomizer is provided with electric regulator (E5).
3. Verify that the faucet (P12) of the powders mixer (or the faucet of the self-cleaning filter P25 - for the versions provided with) is closed.
4. Close the manual distributor's taps (P9) or position the switches of the control electric switchboard (E10) on "OFF"
5. Undo the thumb screw and remove the body of the filter.
6. Extract the cartridge: clean the grill and the retaining O.Ring.

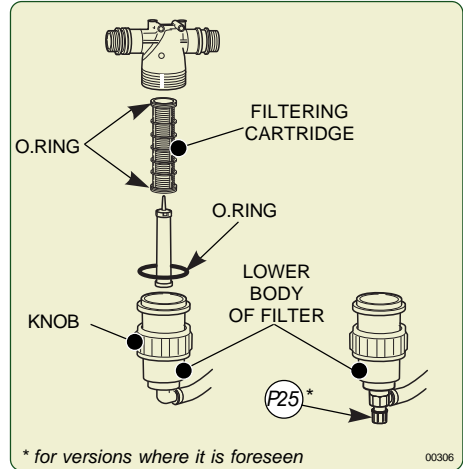

7. Reassemble the cartridge and secure the lid with the thumb screw. **Pay attention to the O-Ring of the lower body during the assembly:** the incorrect sealing of the filter will jeopardise the proper operation of the sprayer and cause loss of the mixture.

13.5 - PURGING OF RESIDUES FROM FILTER

With the machine in operation and the taps of the manual (P9) or electrical (E9) distributor closed. Opening the powder mixer tap (P12) (or the self-cleaning filter faucet P25 - for versions where it is foreseen) the delivery flow will drag possible sludge to the bottom of the filter within the tank through the piping (T6) thus partially cleaning the filtering cartridge. Close the tap when the operation is completed.



When the machine is in operation, check that the drain tap (P12) (or P25) is closed before opening the main feeder.

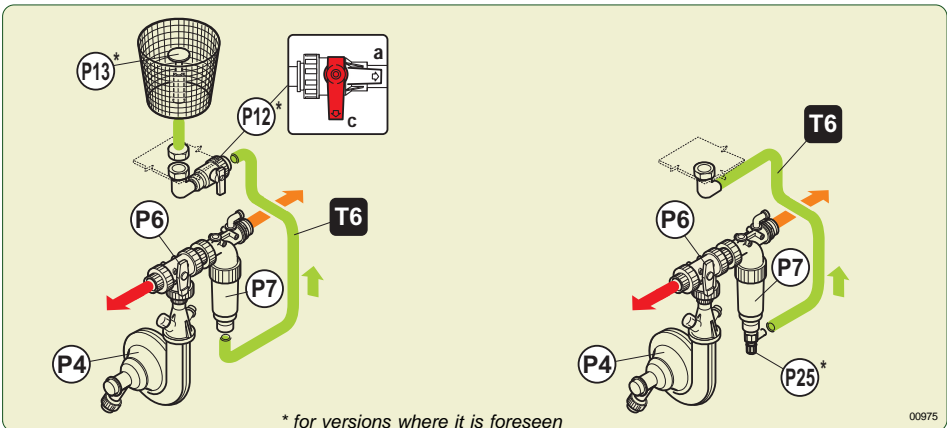

13.6 - CLEANING OF THE FAN



It is advisable for the cleaning of the fan to be carried out at a C.I.M.A service point. Dirt accumulation or incrustations can unbalance the fan, inducing vibrations that could cause breakage

1. Remove the distribution device (head).
2. Remove the fastening collar (1), fixing the fan casing outlet orifice to the union elbow.
3. Remove the two collar (5) fastening bolts, fixing the fan casing to the rear cover.
4. Remove the collar (5), locking the fan casing to the rear cover.
5. Extract the fan casing (2).



The fan hasn't to be disassembled.

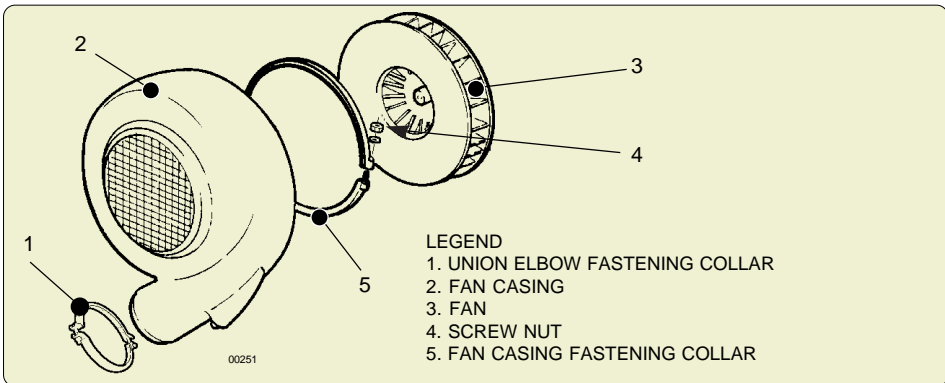

6. Clean the fan, by avoiding to use high pressure water jets: they can cause infiltrations into the fan shaft support and consequently damage the bearings.
7. Mount back the casing (2), by paying a particular attention to get it perfectly coupled with the rear cover.
8. Fasten the fan casing, with the collar (5), to the rear cover and with the collar (1) to the union elbow.
9. Mount back the distribution device (head).



Carefully tighten all the fastening collars' bolts.

13.7 - FAN BELT TENSIONER

Check length "L" of the spring (refer to Picture): it should be in tension between 9 and 12 cm.



If the fan control belt has to be replaced, the correct tensioning of the same one (spring length) has to be OBLIGATORILY checked after the first and after the second operation hour. If the value measured exceeds 12 cm, tighten the belt tightener screw, up to get the minimum length (9 cm).

The belt setting will take place within the first 2 operating hours; when that time has elapsed, verify the spring length, according with the time intervals (periodicity) indicated in the "Maintenance

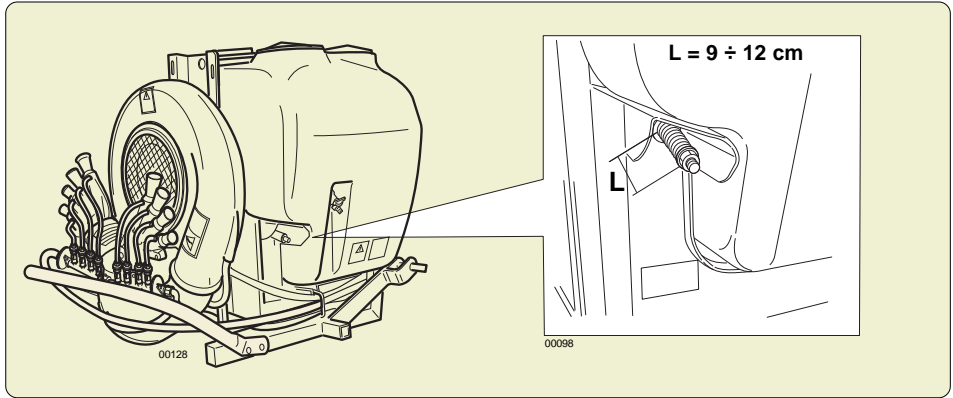

operations' table".

13.8 - PUMP BELT TENSIONER

Check length "L" of the spring (refer to picture): it should be in tension between **4 and 5 cm**. If the value measured exceeds 5 cm, tighten the belt tightener screw, up to get the minimum length (4 cm)

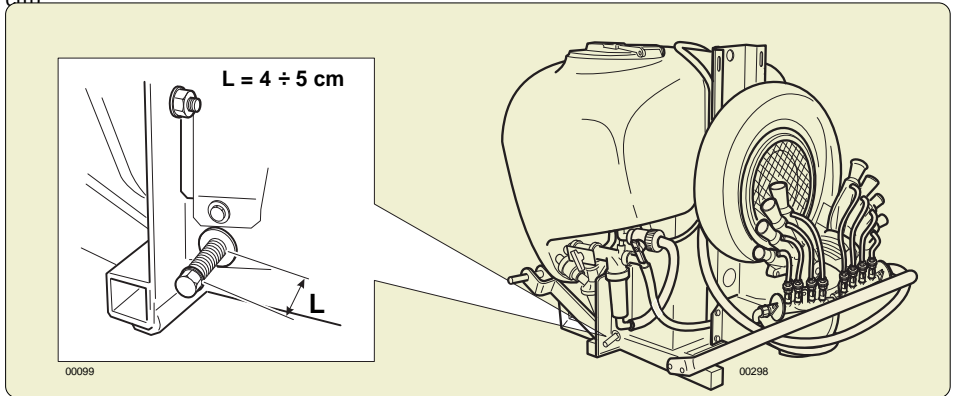

13.9 - TANK REMOVAL OR REPLACEMENT



It is recommended to have the operation performed by a C.I.M.A. assistance point, such a regulation is compulsory in case of REPLACEMENT of the tank.



The operation has to be carried out by complete absence of liquid residuals both inside the tank and in the hydraulic circuit.

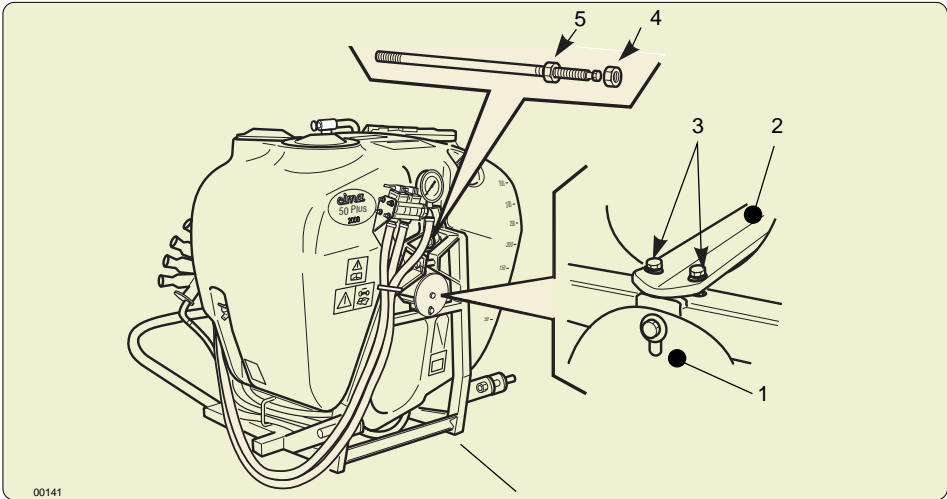

00141

Removal:

1. Free the tank of its hydraulic and pneumatic connections.
2. Dismantle the mobile protection cover (1) of the coupling.
3. Remove the tank securing bracket (2), undoing the 2 screws (3).
4. Undo the external nut (4) of the tie rod.
5. Tighten the internal nut (5) of the tie rod, utilising the spanner provided, moving it away from the plate.
6. Undo the tie rod from its securing point, located in the rear part of the frame. Remove it through the large hole on the frame's plate.
7. Remove the tank.

Installation:

1. Position the main tank on the frame.
2. Re-position the tie-rod in its seat, in other words the smaller one, first inserting it through the big hole.
3. Tightly screw in and secure the tie rod to the rear plate of the frame.
N.B. Lock tightly and with utmost care
4. Unscrew the internal nut (5) of the tie rod, slightly tightening it against the plate.
5. Securely tighten the external nut (4) of the tie rod against the plate.
6. Reassemble the tank's securing bracket (2), fastening it with the 2 screws (3).



Before every intervention, check the proper tightening of the 2 securing screws of the tank's mounting bracket..

7. Reassemble the mobile protection lid of the disengaging device, by securing it with the relevant screw.
8. Reinstall the hydraulic and pneumatic connections.

13.10 - TABLE OF MAINTENANCE OPERATIONS

CHECK	SEASON START TREATMENTS	BEFORE EVERY TREATMENTS	END OF EVERY TREATMENTS	SEASON - END TREATMENTS	RECOMMENDED FREQUENCY
Fan belt-tensioner spring: CHECK LENGTH 9-12cm..	YES	YES	**	**	**
Pump belt-tensioner spring: CHECK LENGTH 4-5cm. .	YES	YES	**	**	**
Fan shaft support: CHECK OIL LEVEL	YES	YES	**	**	8h
Fan shaft support: REPLACE OIL LEVEL	**	**	**	YES	1 year
Tank: CHECK SECURING TIE ROD AND ANCHORING BRACKET	YES	YES	**	**	**
Fan belt-tensioner support: GREASING	**	**	**	YES	200 h
Free wheel: GREASING	**	**	**	YES	200 h
Filter: CHECK CLEANING	YES	YES	YES	YES	**
Fittings and piping: CHECK GOOD CONDITION	YES	YES	**	YES	**
Clamps and fittings: CHECK FOR INTEGRITY, PERFECT SEALING AND TIGHTENING	YES	YES	**	**	**
Wheels: CHECK THE SCREW NUTS TIGHTENING AND TYRES PRESSURE	YES	YES	**	YES	**
Wheel hubs' fastening screws: CHECK THE TIGHTENING	YES	YES	**	YES	**
Hydraulic circuit and tank: COMPLETELY DRAIN AND WASH	**	**	YES	YES	**
Sprayer: EXTERIOR WASHING	**	**	YES	YES	**
Sprayer: STORAGE	**	**	**	YES	**

A. FAULT: By utilising the filler piping the pump doesn't operate (suction)

It is necessary to disengage the drive outlet (PTO) and wait for it to stop rotating before repeating the filling operation.

1. CAUSE: the quantity of water poured into the tank is insufficient to trigger the pump.
REMEDY: *Add water to the tank until the pump starts its cycle.*
2. CAUSE: the filler piping sucks in air.
REMEDY: *Completely submerge the suction filter of the filler piping.*
3. CAUSE: Lack of seal of the pipes.
REMEDY: *Check the tightening of ring nuts, fittings and clamps. Check the efficiency of sealers and that piping elements are not cracked or broken. Replace parts that are possibly found to be defective.*
4. CAUSE: Slipping of the pump's belt.
REMEDY: *Check the tension of the belt-tensioner's spring. (4÷5 cm).*
5. CAUSE: The pump's belt might be broken.
REMEDY: *Replace the belt.*

B. FAULT: Leakage and dripping from the pump

1. CAUSE: Non-sealing of the fittings and clamps connecting the piping to the pump.
REMEDY: *Check for proper tightening of ring nuts and clamps. Check the efficiency of the sealers. Replace parts that are possibly found to be defective.*
2. CAUSE: Mechanical sealing defective.
REMEDY: *Address a C.I.M.A. point of "Sale and Service".*

C. FAULT: Drop in pressure of the hydraulic circuit signalled by the gauge

1. CAUSE: Dirty filter.
REMEDY: *Clean the cartridge*
2. CAUSE: The pump filter is clogged.
REMEDY: *Clean the filter*
3. CAUSE: Faulty sealing of the hydraulic circuit.
REMEDY: *Check the operation of the pump and the tension of its belt. Check the proper tightening of ring nuts, fittings and clamps. Check the efficiency of the sealers and the integrity of the piping. Replace the parts that are possibly found to be defective.*
4. CAUSE: Gauge defective.
REMEDY: *Replace the pressure gauge.*
5. CAUSE: Suction or gauge connection pipe clogged.
REMEDY: *Clean.*

D. FAULT: Variations in the pressure of the hydraulic circuit (marked by the gauge)

1. CAUSE: Lack of seal of the pipes and/or the valves.
REMEDY: *Check the clamping of the ring nuts, the connections and the clamps. Verify the efficiency of the gaskets and the integrity of the pipes. Replace the possibly defective parts.*

2. CAUSE: Residue of product at the entrance of the gauge
REMEDY: *Clean.*
3. CAUSE: Wrong positioning of the circuit-washer faucet (P15) with the circuit-washer tank empty.
REMEDY: *Position the lever of the faucet correctly (P15 - pos". 1") and fill the circuit-washer tank.*
4. CAUSE: Lack of seal of the O-Ring gasket of the pump suction connection (cone).
REMEDY: *check the correct assembling and the efficiency of the O-Ring gasket, if necessary replace the gasket.*

E. FAULT: Vibrations of fan unit.

1. CAUSE: Dirty fan.
REMEDY: *Wash. (It is advisable to refer a C.I.M.A. point of "Sale and Service".*
2. CAUSE: The tractor and of the atomizer PTOs are not lined up or their position determines the overcoming of the maximum work angle of the drive cardan shaft.
REMEDY: *Raise or lower the sprayer in order to realign PTO so that cardan shaft functions correctly (see Paragraph 5.2.1).*

F. FAULT: Anomalous and continuous noisiness together with vibrations of the fan group.

1. CAUSE: Breaking of the fan shaft bearings.
REMEDY: *Address a C.I.M.A. point of "Sale and Service".*
2. CAUSE: Interference fan - case.
REMEDY: *Address a C.I.M.A. point of "Sale and Service".*

G. FAULT: Intermittent operation of the whole distribution device

1. CAUSE: Lack of seal of the hydraulic circuit that goes from the tank (T1) suction pipes to the manual distributor (P9) or to the electrovalves (E9)
REMEDY: *Carefully inspect all the points at which suction of air can take place, including as well those at which no liquid seepage is detected. Check the proper tightening of ring nuts, fittings and clamps. Check the efficiency of the sealers and the integrity of the piping. Reinstate the efficiency and replace parts that might have been found to be defective.*

H. FAULT: Intermittent spraying only on the one side of the distribution device

1. CAUSE: Faulty sealing of the hydraulic circuit going from the manual (P9) or electrical (E9) distributor to the distribution point involved.
REMEDY: *As per point G.1.*

I. FAULT: No spraying action delivered: totally.

1. CAUSE: Clogging up of the grill/filter on the pump, of the pump suction inside the tank or suction pipes of pump clogged up with deposits of hardened plant protection product.
REMEDY: *Clean.*

J. FAULT: No spraying action delivered: totally or only on the one side of the distribution device

1. CAUSE: Manual distributor (P9) taps dirty or clogged, or pump suction piping clogged by hardened product deposits.
REMEDY: Clean.
- 1b. CAUSE: Electrical distributor (E9) taps blocked by incrustations in the closed position.
REMEDY: Remove the cover, act on the opening/closing control rod.
Clean the distributor.
2. CAUSE Fuses of the electrical control panel (E10)
REMEDY: Replace the fuses.
- 3b. CAUSE: Power cable W1 of the electrical panel interrupted or oxidized connectors of the electric distributor (E7)
REMEDY: Connect and possibly replace the defective components correctly.
4. CAUSE: Defective electrical connections.
REMEDY: Address a C.I.M.A. point of "Sale and Service".
5. CAUSE: Pump defective (only in case total delivery missing).
REMEDY: Address a C.I.M.A. point of "Sale and Service".
6. CAUSE: Broken pump belt.
REMEDY: Replace the belt (See Paragraph 15.1).



THE CAUSES AND REMEDIES FOR THE FAULTS CONCERNING THE DELIVERY OF THE SPRAYING BY ONE OR MORE DIFFUSERS ARE INDICATED IN THE USE AND MAINTENANCE MANUAL OF EACH SPRAYHEAD.

K. FAULT: Anomalous consumption of oil of the fan support.

1. CAUSE: Oil drain plug not adequately closed.
REMEDY: Check, reposition and adequately close then handle the filling up of the oil level.
2. CAUSE: Damaged flexible oil waste pipe or damaged pipe fixing clamp.
REMEDY: Check, adequately then handle the filling up of the oil level. Replace the damaged parts: rivolgersi al punto "Vendita - Assistenza" C.I.M.A.
3. CAUSE: Drawings from the support mechanical seals.
REMEDY: Address a C.I.M.A. point of "Sale and Service".

L. FAULT: Noisiness (ticking) coming from the upper part of the mechanical drive at low runnings, above all when slowing down.

2. CAUSE: Consumption of the damping elements of the fan release.
REMEDY: Eventually have it replaced; address a C.I.M.A. point of "Sale and Service".

M. FAULT: Noisiness (ticking) coming from the lower part of the mechanical drive at low runnings, above all when slowing down.

1. CAUSE: Lack of grease in the multiplier free wheel.
REMEDY: Grease the free wheel.

15 REPAIRS ALLOWED 15



THE OWNER AND/OR THE OPERATOR OF THE SPRAYER ARE NOT PERMITTED TO MODIFY THE STRUCTURE OR THE SPECIFIC OPERATION OF THE SPRAYER ITSELF. ANY REPAIRING INTERVENTION HAS TO BE CARRIED OUT EITHER AT THE DEALERS' OR AT THE C.I.M.A. S.p.A. AUTHORIZED WORKSHOPS, OTHERWISE ANY KIND OF WARRANTY IMMEDIATELY CEASES AND C.I.M.A. S.p.A. IS CLEARED OF ANY CONSEQUENT AND/OR IMPLIED RESPONSIBILITY.

15.1 - REPLACEMENT OF PUMP CONTROL BELT



Stop the engine and remove the key from the tractor's control panel.

1. Remove the steel-plate guard located on the frame behind the pump, unscrewing the two securing screws.
2. Completely unscrew the tightener spring adjusting screw: the pump support plate will so freely turn.
3. Unscrew the fixing screw and turn the mobile protection cover to approach the tunnel of the disengagement.
4. Insert the pump control belt into the tunnel of fan disengagement. Feed the front part below the disengagement area and the rear area above, until it enters the upper pulley groove beyond the disengagement portion.
5. Insert the belt in the pump's pulley groove.
6. Reinstall the spring of the belt-tensioner according to the suggested tensioning conditions.
7. Re-assemble the steel-plate protection guards.

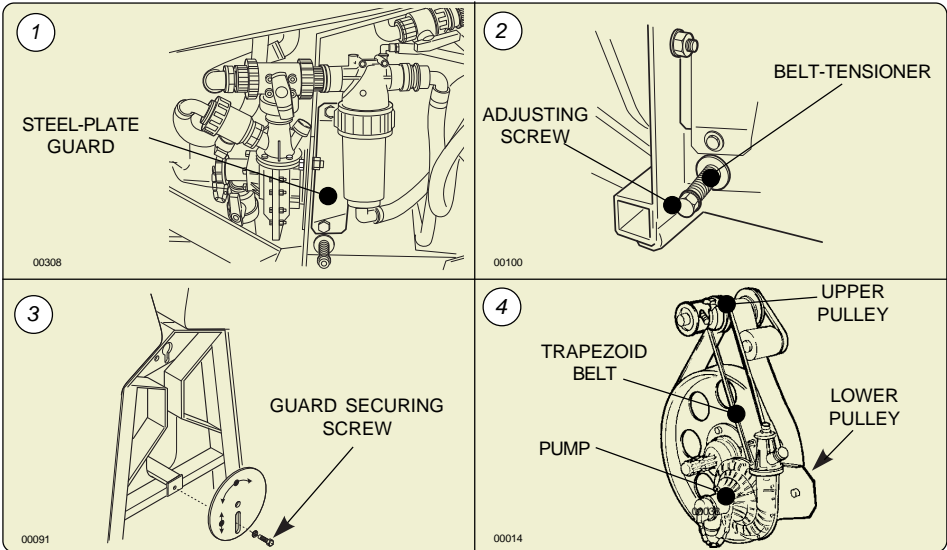

Carefully tighten the screws that were undone during the belt replacement.

15.2. - REPLACEMENT OF ELECTRICAL PANEL'S FUSES



Stop the engine and remove the ignition key from the tractor's control panel.

1. Replace the faulty fuse and screw back the cover.
 - Fuse: 10 A, delayed.



ANY OTHER INTERVENTION HAS TO BE CARRIED OUT AT A C.I.M.A. CUSTOMERS' SERVICING CENTER.

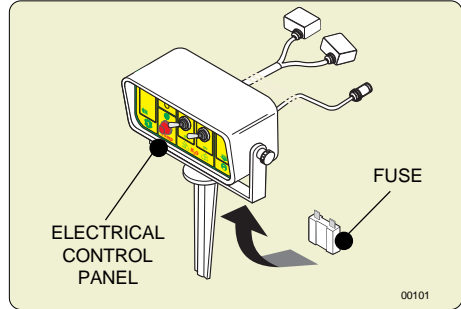

15.3. - PRESSURE GAUGE REPLACEMENT



Stop the motor and remove the starting key from the tractor control panel.

1. Unscrew and decouple the pipe-holder (3) from the connection of the pressure gauge (1).
2. Unscrew the ring nut (2) and remove the pressure gauge (1).
3. Replace the faulty pressure gauge (1).
4. Mount the new pressure gauge, by carrying out in reverse order the steps mentioned for its removal.

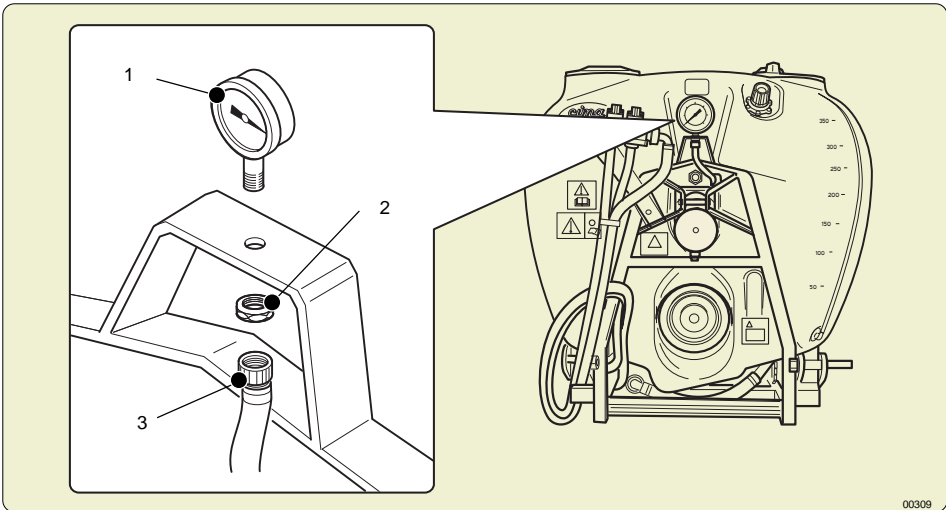

ANY OTHER INTERVENTION HAS TO BE CARRIED OUT AT A C.I.M.A. CUSTOMERS' SERVICING CENTER.

15.4. - INSPECTION AND CLEANING PUMP FILTER



The pump is provided by the suction side of a filter to prevent the accidental entry of foreign bodies in the pump body, such a possibility does not constitute a hazard and can only cause damage to the impeller shown by a drop in pressure reported by gauge..

The clogging of the filter pump causing an immediate lowering of pressure delivery.
If necessary check the cleanliness of the filter:

1. Position the lever of the three-way cock (P6) in position "c".
2. Position the lever of the three-way cock (P2) (or the cock P15 for the versions fitted with spray-line rinsing tank) in position "c".
3. Unscrew the plug (1) and eventually remove the foreign body present in to the filter.
4. If necessary, unscrew the nuts (2) and remove the filter (4), to clean completely.
5. Replace the filter by paying attention to the conditions and the proper placement of the O.Ring (5).
6. Close the screw plug (1).
7. Position the lever of the three-way cock (P2) (or the cock P15 for the versions fitted with spray-line rinsing tank) in position "a".
8. Position the lever of the three-way cock (P6) in position "a" - WORKING.

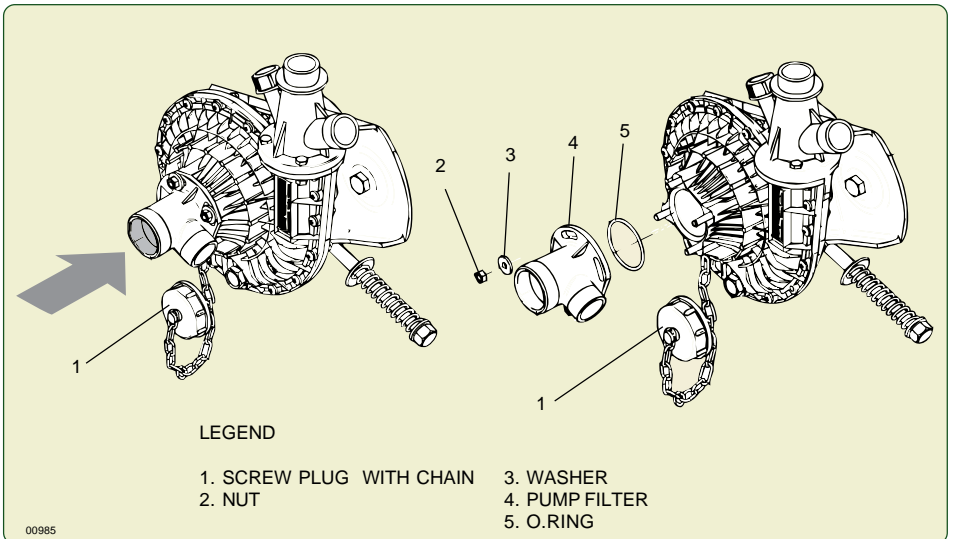

15.5. - CHECK HYDRAULIC DELIVERY



TESTING OF HYDRAULIC DELIVERY MUST BE MADE WITH THE SPRAYER ON A FLAT SURFACE. THE PROOF IS IN THE DETECTION OF TIME TO PROVIDE A KNOWN QUANTITY CONTENT OF LIQUID IN TANK

1. Disengage the fan (for versions where it is foreseen): see Paragraph 8.1.a.
2. Close the taps of the 2-way distributor:
 - a. if manual (P9), the levers are to be lowered (horizontally positioned);
 - b. if electric, position to "OFF" the quick-break switches (E10).
3. Fill the tank with about 250 liters of clean water (**USED AS REFERENCE THE MARK OF LEVEL INDICATOR ON THE TANK** - see Paragraphs 8.2/8.3).
4. Engage the fan (for versions where it is foreseen): see Paragraph 8.1.b.



The claimed performance is obtained with the PTO at 540 rpm. and with the fan running .

For correct verification result this condition MUST ALWAYS BE RESPECTED.

5. Bring the PTO to 540 rpm rotation rate.
6. Open the taps of the 2-way distributor:
 - a. if manual (P9), the levers are to be raised (vertically positioned);
 - b. if electric, position to "ON" the quick-break switches (E10).
7. Regulate the operating pressure, by acting on the pressure regulator (P5) (or electric E5) with the distributor, hand (P9) or electric (E9), open (DISTRIBUTION) and regulate the position of calibration disc (P11) in accord to "Delivery chart" relating to the sprayhead used.
8. Close the taps of the 2-way distributor:
 - a. if manual (P9), the levers are to be lowered (horizontally positioned);
 - b. if electric, position to "OFF" the quick-break switches (E10).
9. Add water to the tank until you reach the mark of 300 liters (reference).
10. Add additional 25 liters of water to the tank, the quantity required for the verification flow, using a graduated container or by weighing the amount payable (1liter = 1 kg).
11. Open the taps of the 2-way distributor (manual or electric) to start delivery.
12. Continue the delivery until the water reaches the mark 300 liters on the level indicator.



NOTED THE TIME ELAPSED BETWEEN THE RELEASE DELIVERY AND THE ACHIEVEMENT OF MARK 300 LITERS .

13. Apply the formula:
$$Q = \left(\frac{60}{t} \right) \times 25$$

where: **Q**, is the hourly delivery detected (lt./h);
t, is the time measured in minutes and seconds (centesimal).

TESTING IS CONSIDERED WITH POSITIVE RESULTS (machine properly calibrated) WHEN THE VALUE CALCULATED "Q" IS INDICATED ON THE "DELIVERY CHART" WITH A TOLERANCE OF ± 2.5%.

In case of different values to verify the efficiency of the pipe, the fittings, the pressure gauge and the proper positioning of the calibration discs (P11), if necessary replace the damaged or defective, and the test repeated.

16 INTEGRATIVE DIAGRAMS 16

16.1 - HYDRO-PNEUMATIC DIAGRAM

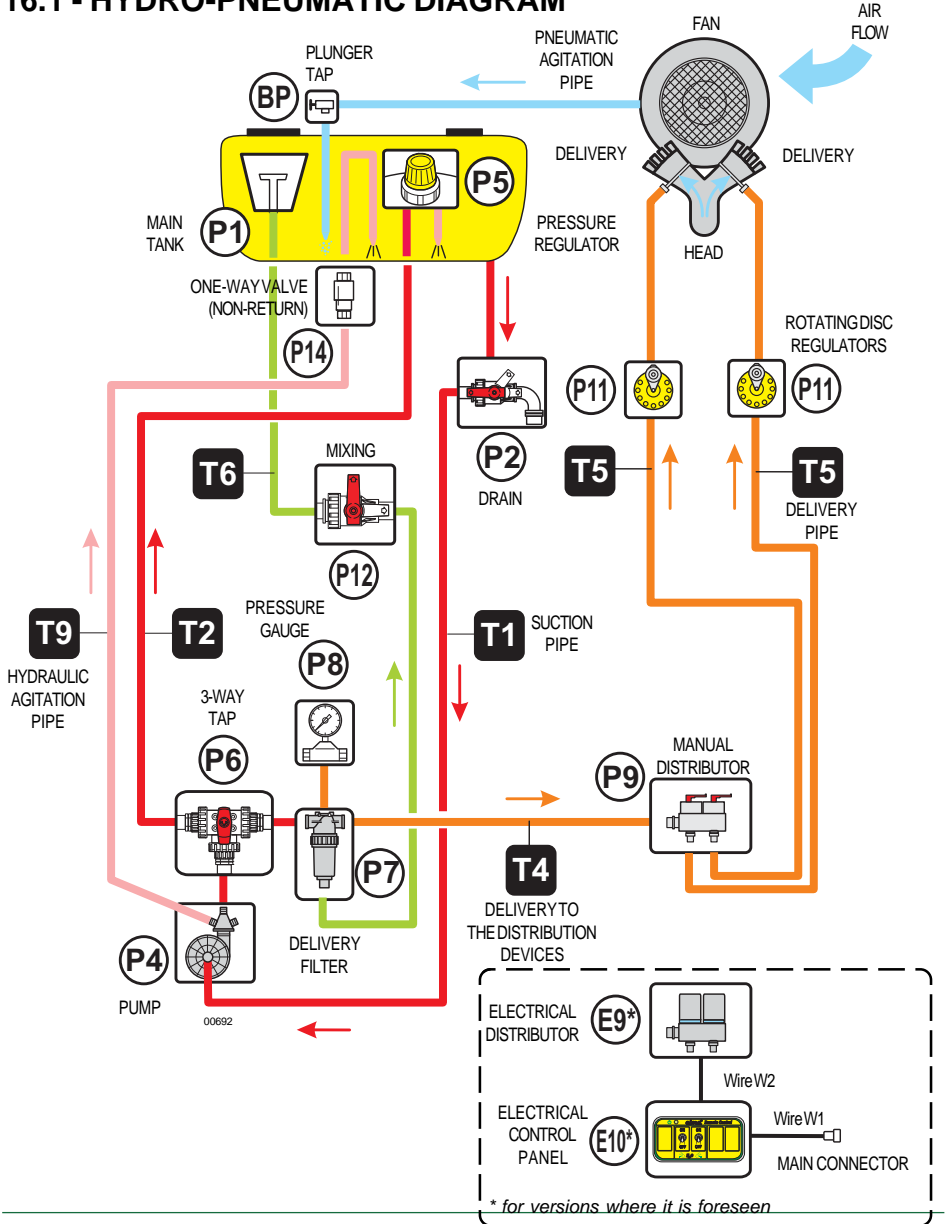

E.P.A. Versions

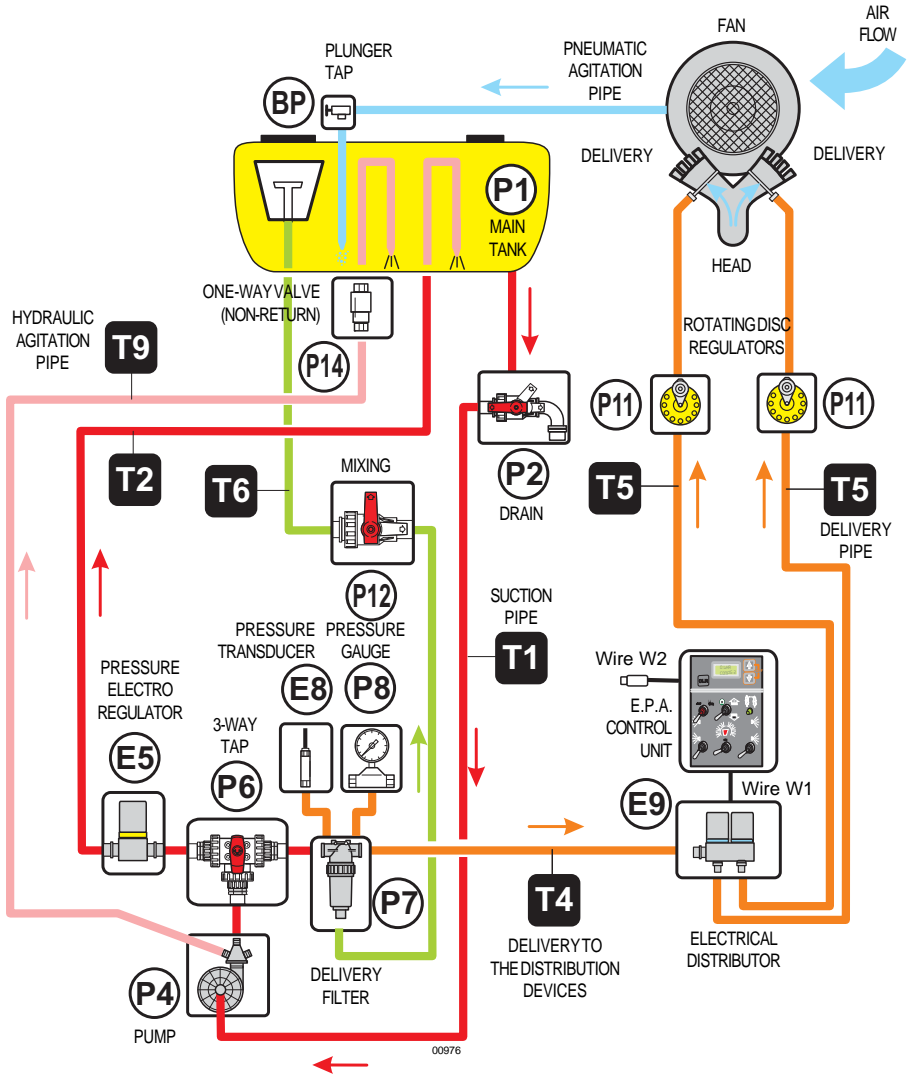

E.P.A. Versions with unit-washing tank

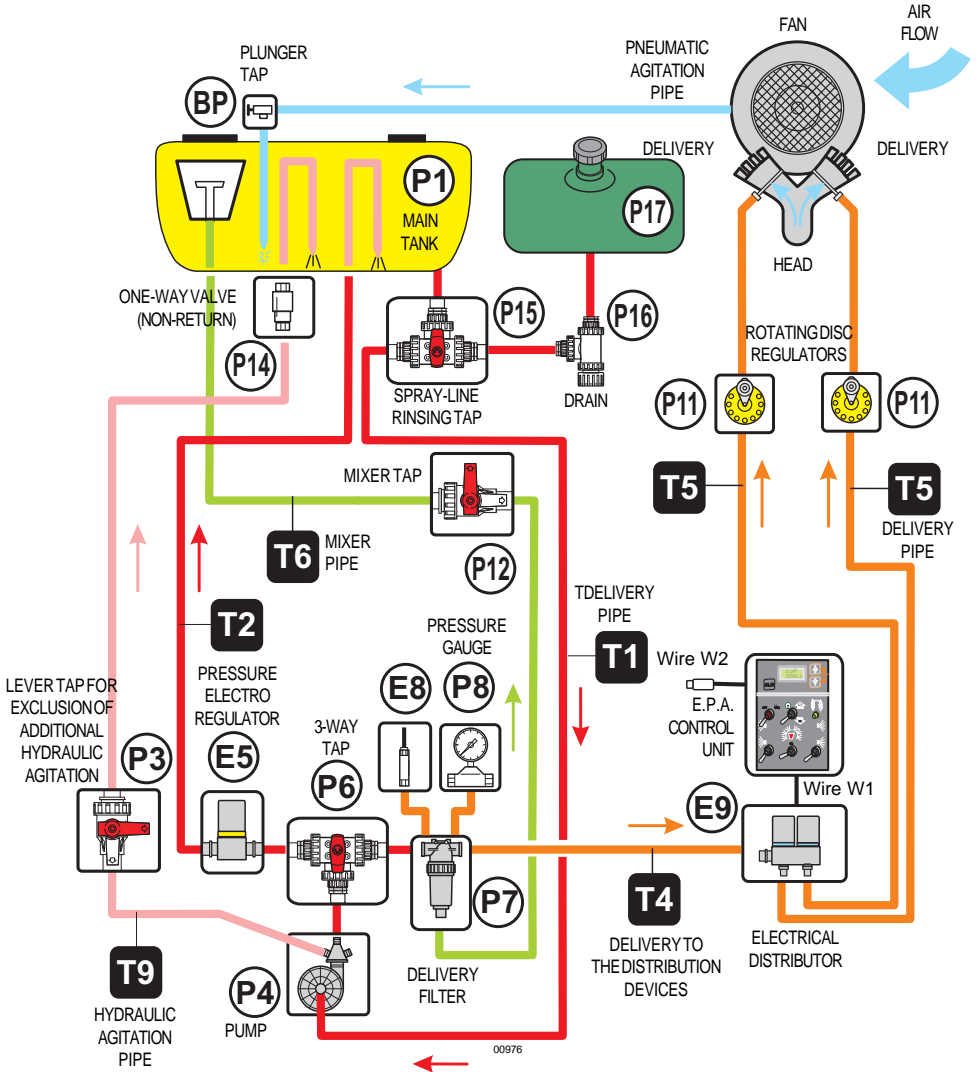

16.2 - WIRING DIAGRAM

(for versions where it is foreseen)

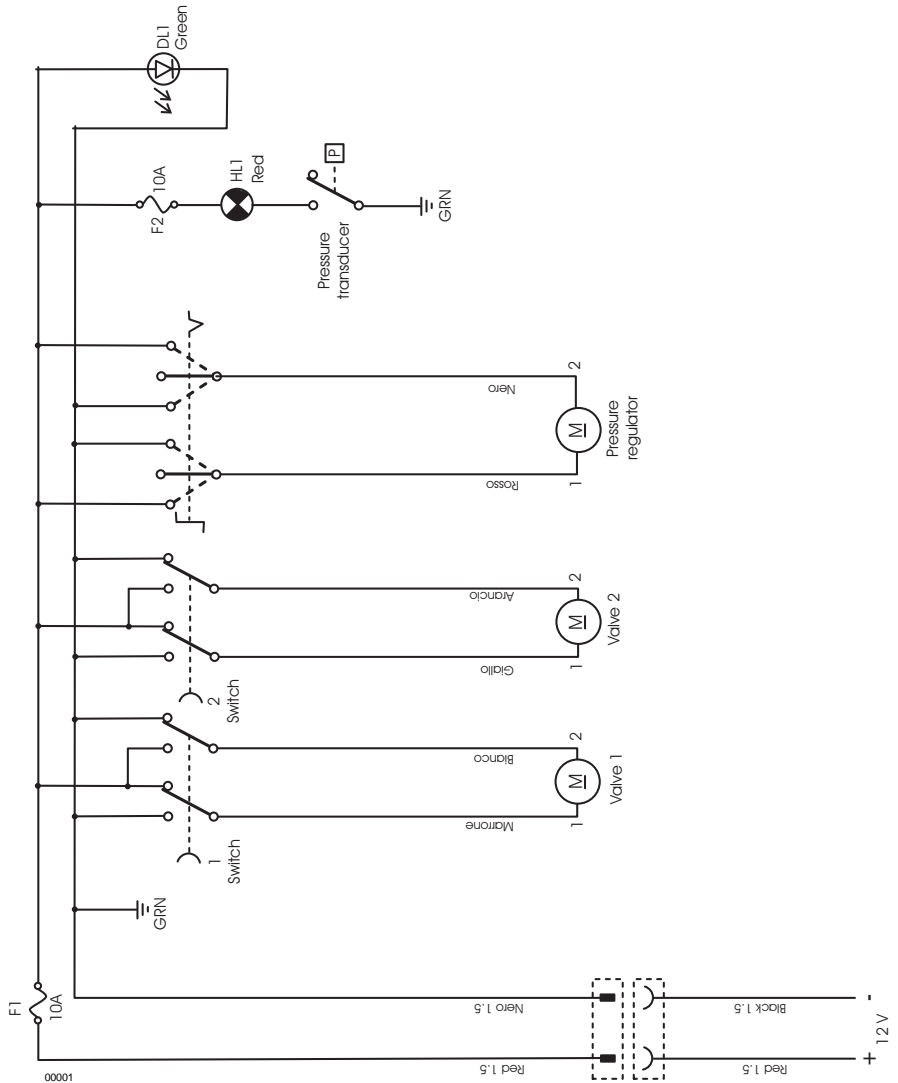

Sprayer model	Aerial noise emitted L qA - dB(A)
Plus 42	89,0 +- 0,2
Plus 45	92,4 +- 0,2
Plus 50	99,4 +- 0,2
Plus 55	95,4 +- 0,2
Plus 55S	95,4 +- 0,2
Plus 55E	95,4 +- 0,2

UMAPT013

18 ATTACHMENT: DECLARATION OF COMPLIANCE 18



DICHIARAZIONE DI CONFORMITÀ ai sensi della direttiva 98/37/CE del 22/06/98 e successive modificazioni		CE		
DECLARATION OF CONFORMITY as directive: 98/37/CE - 22/06/98 and subsequent modifications	CE	DECLARATION DE CONFORMITE selon la directive 98/37/CE - 22/06/98 et modifications ultérieures	CE	
ÜBERREINSTIMMUNGS-ERKLÄRUNG lt. Direktiven 98/37/CE - 22/06/98 und nachfolgenden Änderung	CE	DECLARACION DE CONFORMIDAD con arreglo a la Directiva 98/37/CE - 22/06/98 y modificaciones siguientes	CE	
CIMA s.p.a. 27040 MONTÙ BECCARIA (PV) - ITALY - Loc. Molino Quaroni				
DICHIARA SOTTO LA PROPRIA RESPONSABILITÀ CHE LA MACCHINA	HEREWITH DECLARES, UNDER THEIR PERSONAL RESPONSIBILITY THAT THE FOLLOWING MACHINE	DECLARONS SOUS NOTRE RESPONSABILITÉ QUE LA MACHINE DÉCRITE CI-APRÈS	ERSTÄTTET HERUNTER IHREN PERSÖNLICHEN VERANTWORTUNG, DAS DIE MASCHINE	DECLARA BAJO LA PROPIA RESPONSABILIDAD QUE LA MÁQUINA
SERIE, TIPO - MODEL, TYPE - SERIE, TYPE - MODEL, TYP - SERIE, TIPO:				
<input style="width: 100%; height: 20px;" type="text"/>				
MATRICOLA - SERIAL - MATRICULE - SERIAL - MATRICULA NR.:				
<input style="width: 100%; height: 20px;" type="text"/>				
E' conforme ai Requisiti essenziali di Sicurezza e di Tutela della Salute di cui alla Direttiva 98/37/CE del 22/06/98 e sue successive modificazioni. Per la verifica della Conformità di cui alla Direttiva sopra menzionata, sono state consultate le seguenti Norme armonizzate:				
EN 294 EN 349 EN 907				
Conforms to the essential Safety regulation as well as the Health requirements as per European Economic Community Directive 98/37/CE - 22/06/98 and subsequent modifications. For the verification of conformity as per above mentioned directives the following official EN norms have been consulted. Harmonized norms:			Est conforme aux exigences de Sécurité et de Sauvegarde de la Santé dont à la Directive 98/37/CE - 22/06/98 et modification ultérieures. Pour vérifier la conformité aux directives susmentionnées, ont été prises en compte les normes suivantes. Normes harmonisées:	
EN 294 EN 349 EN 907			EN 294 EN 349 EN 907	
Stimmt mit den wesentlichen Requiriten der Sicherheitsvorschriften und der Gesundheitsvorsorge lt. EWG Direktive Nr. 98/37/CE - 22/06/98 und nachfolgenden Änderungsbestimmungen. Für die Überprüfung dieser Übereinstimmungs-Erklärung lt. obigen Direktiven sind folgende Normen konsultiert worden. Normen:			Cumple con los requisitos esenciales de Seguridad y de Preservación de la Salud contemplados en la Directiva 98/37/CE - 22/06/98 y modificaciones siguientes. Para comprobar la conformidad a la que se refieren las Directivas anteriormente citadas, se han consultado las siguientes Normas Armonizadas.	
EN 294 EN 349 EN 907			EN 294 EN 349 EN 907	
Responsabile della Sicurezza - TM Security Officer - Responsable Sécurité et Homologation - Der Sicherheits-Beamte - Responsable de la Seguridad				
Smeraldi Paolo				
Montù Beccarà (PV) Data, Date, Datum, Datum, Fecha, _____				



THE OWNER AND/OR THE OPERATOR OF THE SPRAYER ARE NOT PERMITTED TO MODIFY THE STRUCTURE OR THE SPECIFIC OPERATION OF THE SPRAYER ITSELF. ANY REPAIRING INTERVENTION HAS TO BE CARRIED OUT EITHER AT THE DEALERS' OR AT THE C.I.M.A. S.p.A. AUTHORIZED WORKSHOPS, OTHERWISE ANY KIND OF WARRANTY IMMEDIATELY CEASES AND C.I.M.A. S.p.A. IS CLEARED OF ANY CONSEQUENT AND/OR IMPLIED RESPONSIBILITY.

18.1 - Warranty

The goods sold are covered by a general warranty that ensures the good quality of the materials, solid construction and regular operation for twelve months from the date of delivery.

During the warranty period, C.I.M.A. S.p.A. pledges to replace, free of charge, the parts which, in his unquestionable judgement, are considered defective, provided that the flaws and defects cannot be attributed to poor use or maintenance of the product or an unreasonable, inappropriate and unsuitable use of such product with respect to the technical instructions supplied by C.I.M.A. S.p.A.

The products which have been modified, repaired, assembled or tampered with by a third party, consumption materials and the parts subject to wear and tear are excluded from the warranty.

The replacements will be made free CIMA S.p.A. works and the buyer will be responsible for all shipping and return expenses.

The buyer will be responsible for the costs of the labour needed to replace the parts considered defective. The resolution of the contract and any compensation for damage cannot be claimed by the buyer except for serious faults to be proven by said buyer.

The warranty will no longer be extended to the buyer if he does not respect the agreed upon payment procedures and terms.

19.2 - Reporting defects in goods

The claims for flaws or defects in the goods shall be submitted within eight days from when such goods are received or from when hidden defects are discovered, in writing, by means of a registered letter. No claim can be made, nor as an exception, in a court of law if the goods, for which the claim is submitted, have not been regularly paid.

Any claim concerning a single delivery of goods will not exonerate the buyer from his obligation to pick-up the remaining quantity of goods within the limit of the order.

19.3 - To pass safety information

The buyer is responsible towards the final user for the safety information shown on the sale documentation, concerning use limit, performances and product features.

19.4 - Validity and acceptance

The guarantee is valid if the CERTIFICATE OF GUARANTEE is sent, to C.I.M.A. S.p.A., with every part of it filled in, within 30 days from the date of purchase (referring to the date of the postmark).



CERTIFICATE OF WARRANTY

Copy for the owner (to be kept in the manual "Instructions for the use and maintenance)

Last name, Name or
NAME OF THE FIRM

ADDRESS

Place PROVINCE ZIP

e.mail (*) telephone (*)

Date of purchase INVOICE N.

MACHINE MOD. MATRICULATION N.

SPRAYHEAD MOD.

Dealer's stamp (compulsory)

(*) NOT COMPULSORY DATA

PRIVACY

Consent for the personal data processing– **PROTECTION OF THE PRIVACY .**

I authorize you, according to the D.Lgs. 196/03 "Consolidated Text about the Privacy" to the processing of my personal data in observance of the law above mentioned, for the indicated purposes, and so that they can be communication to the subjects for the declared purposes.

Date Signature

Warranty conditions

1. Warranty

The goods sold are covered by a general warranty that ensures the good quality of the materials, solid construction and regular operation for twelve months from the date of delivery.

During the warranty period, C.I.M.A. S.p.A. pledges to replace, free of charge, the parts which, in his unquestionable judgement, are considered defective, provided that the flaws and defects cannot be attributed to poor use or maintenance of the product or an unreasonable, inappropriate and unsuitable use of such product with respect to the technical instructions supplied by C.I.M.A. S.p.A. The products which have been modified, repaired, assembled or tampered with by a third party, consumption materials and the parts subject to wear and tear are excluded from the warranty. The replacements will be made free CIMA S.p.A. works and the buyer will be responsible for all shipping and return expenses. The buyer will be responsible for the costs of the labour needed to replace the parts considered defective. The resolution of the contract and any compensation for damage cannot be claimed by the buyer except for serious faults to be proven by said buyer. The warranty will no longer be extended to the buyer if he does not respect the agreed upon payment procedures and terms.

2. Reporting defects in goods

The claims for flaws or defects in the goods shall be submitted within eight days from when such goods are received or from when hidden defects are discovered, in writing, by means of a registered letter.

No claim can be made, nor as an exception, in a court of law if the goods, for which the claim is submitted, have not been regularly paid.

Any claim concerning a single delivery of goods will not exonerate the buyer from his obligation to pick-up the remaining quantity of goods within the limit of the order.

3. To pass safety information

The buyer is responsible towards the final user for the safety information shown on the sale documentation, concerning use limit, performances and product features.

4. Validità ed accettazione

The guarantee is valid if the CERTIFICATE OF GUARANTEE is sent, to C.I.M.A. S.p.A., with every part of it filled in, within 30 days from the date of purchase (referring to the date of the postmark).

Informative according to the D. L. n. 196 of the 2003 ("Code in matter of protection of the personal data")

Dear customer,

according to art. 13 of the D.Lgs. 196/03 "Unique Text on Privacy" (referred to as 'Law' here below) we would like to inform you about the following:

1) the personal data given to C.I.M.A. S.p.A. when filling in the "Warranty Certificate" will be processed respecting the above mentioned regulations and the rules of privacy stated there in;

2) according to art.4, paragraph 1, lett. a) of the Law, the handling of personal data signifies "whatever operation or set of operations carried out (even without the aid of electronic instruments) regarding the collection, recording, organization, conservation, research, handling, modification, selection, extracting of details, comparison of, use of, connecting to, blockage, passing on, distributing, cancellation and destruction of data, even if not recorded in a data bank";

The handling of the personal data given is carried out by automatized and non automatized instruments, with controlled access and as specified by clause B of the Law;

3) the data are processed to an institutional end, in connection with or useful to the activities of C.I.M.A. S.p.A. for filing, processing and management;

4) the data are collected and recorded so that access is only allowed to authorized persons and they may be processed exclusively by C.I.M.A. S.p.A. to the above mentioned end;

5) the collected data may only be given to a third party exclusively in connection with accounting imposed by fiscal law and in the case of demands from the judicial authority.

In addition we inform you that any interested party may exercise his rights mentioned in art.7 of the Law; in the exercise of such rights the interested party may delegate or give a proxy, in writing, to persons or associations. The authority to carry out this processing is C.I.M.A. S.p.A., represented in person by a lawyer.

The data processing is done by instruments fit to guarantee the safety and privacy as specified in clause B of the Law.



CERTIFICATE OF WARRANTY

The warranty will not be considered valid if this coupon, with every part of it filled in, is not mailed to the following address: C.I.M.A. S.p.A. - 27040 Montù Beccaria, Loc. Molino Quaroni - (PV) - Italy), or sent by fax to the following number: +39.0385.246637, within 30 days from the date of purchase.

Last name, Name or
NAME OF THE FIRM

ADDRESS

Place PROVINCE ZIP

e.mail (*) telephone (*)

Date of purchase INVOICE N.

MACHINE MOD. MATRICULATION N.

SPRAYHEAD MOD.

Dealer's stamp (compulsory)

(*) NOT COMPULSORY DATA

PRIVACY

Consent for the personal data processing – **PROTECTION OF THE PRIVACY** .

I authorize you, according to the D.Lgs. 196/03 "Consolidated Text about the Privacy" to the processing of my personal data in observance of the law above mentioned, for the indicated purposes, and so that they can be communication to the subjects for the declared purposes.

Date Signature

CUT ALONG THE DOTTED LINE

Warranty conditions

1. Warranty

The goods sold are covered by a general warranty that ensures the good quality of the materials, solid construction and regular operation for twelve months from the date of delivery.

During the warranty period, C.I.M.A. S.p.A. pledges to replace, free of charge, the parts which, in his unquestionable judgement, are considered defective, provided that the flaws and defects cannot be attributed to poor use or maintenance of the product or an unreasonable, inappropriate and unsuitable use of such product with respect to the technical instructions supplied by C.I.M.A. S.p.A. The products which have been modified, repaired, assembled or tampered with by a third party, consumption materials and the parts subject to wear and tear are excluded from the warranty. The replacements will be made free CIMA S.p.A. works and the buyer will be responsible for all shipping and return expenses. The buyer will be responsible for the costs of the labour needed to replace the parts considered defective. The resolution of the contract and any compensation for damage cannot be claimed by the buyer except for serious faults to be proven by said buyer. The warranty will no longer be extended to the buyer if he does not respect the agreed upon payment procedures and terms.

2. Reporting defects in goods

The claims for flaws or defects in the goods shall be submitted within eight days from when such goods are received or from when hidden defects are discovered, in writing, by means of a registered letter.

No claim can be made, nor as an exception, in a court of law if the goods, for which the claim is submitted, have not been regularly paid.

Any claim concerning a single delivery of goods will not exonerate the buyer from his obligation to pick-up the remaining quantity of goods within the limit of the order.

3. To pass safety information

The buyer is responsible towards the final user for the safety information shown on the sale documentation, concerning use limit, performances and product features.

4. Validità ed accettazione

The guarantee is valid if the CERTIFICATE OF GUARANTEE is sent, to C.I.M.A. S.p.A., with every part of it filled in, within 30 days from the date of purchase (referring to the date of the postmark).

Informative according to the D. L. n. 196 of the 2003 ("Code in matter of protection of the personal data")

Dear customer,

according to art. 13 of the D.Lgs. 196/03 "Unique Text on Privacy" (referred to as 'Law' here below) we would like to inform you about the following:

1) the personal data given to C.I.M.A. S.p.A. when filling in the "Warranty Certificate" will be processed respecting the above mentioned regulations and the rules of privacy stated there in;

2) according to art.4, paragraph 1, lett. a) of the Law, the handling of personal data signifies "whatever operation or set of operations carried out (even without the aid of electronic instruments) regarding the collection, recording, organization, conservation, research, handling, modification, selection, extracting of details, comparison of, use of, connecting to, blockage, passing on, distributing, cancellation and destruction of data, even if not recorded in a data bank";

The handling of the personal data given is carried out by automatized and non automatized instruments, with controlled access and as specified by clause B of the Law;

3) the data are processed to an institutional end, in connection with or useful to the activities of C.I.M.A. S.p.A. for filing, processing and management;

4) the data are collected and recorded so that access is only allowed to authorized persons and they may be processed exclusively by C.I.M.A. S.p.A. to the above mentioned end;

5) the collected data may only be given to a third party exclusively in connection with accounting imposed by fiscal law and in the case of demands from the judicial authority.

In addition we inform you that any interested party may exercise his rights mentioned in art.7 of the Law; in the exercise of such rights the interested party may delegate or give a proxy, in writing, to persons or associations. The authority to carry out this processing is C.I.M.A. S.p.A., represented in person by a lawyer.

The data processing is done by instruments fit to guarantee the safety and privacy as specified in clause B of the Law.



cima[®] S.p.A.

27040 Montù Beccaria - Loc. Molino Quaroni - (PV) - ITALIA

Tel. +39.0385.246636 r.a. - Fax +39.0385.246637

<http://www.cima.it>