



**PLUS**

# OPERATION AND MAINTENANCE INSTRUCTIONS

**cima**® S.p.A.

27040 Montù Beccaria - Loc. Molino Quaroni - (PV) - ITALIA  
Tel. +39.0385.246636 r.a. - Fax +39.0385.246637  
<http://www.cimaitalia.com>

**cima**®

**atomizzatori e impolveratori**

Dear Customer, thank you very much!

We want to congratulate with you, for having chosen a **cima**® sprayer.

Your choice shows the wisdom of the well-informed Purchaser, aware of the fact, that the required features of quality, technique and reliability must be satisfied at the right price!

Our continuous engagement in R&D and in testing our machines allows us to realize products able to offer the best performances, a high reliability and a great easiness of use at the same time !

Our first goal, is to get our Customers happy for having met us!

The "Spare parts catalogue" of this sprayer/sprayhead is available in the "restricted area" on website [www.cima.it](http://www.cima.it).

In order to accede, use:  
User name: **sprayer**  
Password: **844719KE**

Where we are



# LOW-VOLUME SPRAYING ATOMISER CARRIED

**Plus 42-45**  
**Plus 50-55-55S-55E**

Serial Number: .....

## OPERATING AND MAINTENANCE INSTRUCTIONS

***cima***<sup>®</sup> S.p.A.

27040 Montù Beccaria - Loc. Molino Quaroni - (PV) - ITALIA  
Tel. +39.0385.246636 r.a. - Fax +39.0385.246637  
<http://www.cimaitalia.com>

**19ATTACHMENT: DECLARATION OF COMPLIANCE19**



<b>DICHIARAZIONE DI CONFORMITÀ</b>		<b>CE</b>
ai sensi della direttiva 98/37/CE del 22/06/98 e successive modificazioni		
<b>DECLARATION OF CONFORMITY</b>	<b>CE</b>	<b>DECLARATION DE CONFORMITE</b>
as directive: 98/37/CE - 22/06/98		selon la directive 98/37/CE - 22/06/98
and subsequent modifications		et modifications ultérieures
<b>ÜBEREINSTIMMUNGS-ERKLÄRUNG</b>	<b>CE</b>	<b>DECLARACION DE CONFORMIDAD</b>
It. Direktiven 98/37/CE - 22/06/98		con arreglo a la Directiva 98/37/CE - 22/06/98
und nachfolgenden Änderung		y modificaciones sucesivas
<b>CIMA s.p.a. 27040 MONTÙ BECCARIA (PV) - ITALY - Loc. Molino Quaroni</b>		
<b>DICHIARA</b> SOTTO LA PROPRIA RESPONSABILITÀ CHE LA MACCHINA:	<b>HEREWITH DECLARES</b> UNDER THEIR PERSONAL RESPONSIBILITY THAT THE FOLLOWING MACHINE:	<b>DECLARONS SOUS</b> NOTRE RESPONSABILITÉ QUE LA MACHINE DÉCRITE CI-APRÈS:
		<b>DECLARA</b> BAJO LA PROPIA RESPONSABILIDAD QUE LA MÁQUINA:
<b>SERIE, TIPO - MODEL, TYPE - SERIE, TYPE - MODELL, TYP - SERIE, TIPO:</b>		
<input style="width: 100%;" type="text"/>		
<b>MATRICOLA - SERIAL - MATRICULE - SERIAL - MATRICULA NR.:</b>		
<input style="width: 100%;" type="text"/>		
<p>E' conforme ai Requisiti essenziali di Sicurezza e di Tutela della Salute di cui alla Direttiva 98/37/CE del 22/06/98 e sue successive modificazioni. Per la verifica della Conformità di cui alle Direttive sopra menzionate, sono state consultate le seguenti: Norme armonizzate: EN 294 EN 349 EN 907.</p>		
<p>Conforms to the essential Safety regulation as well as the Health requirements as per European Economic Community Directive 98/37/CE - 22/06/98 and subsequent modifications. For the verification of conformity as per above mentioned directives the following norms have been consulted: Harmonized norms: EN 294 EN 349 EN 907.</p>	<p>Est conforme aux exigences de Sécurité et de Sauvegarde de la Santé dont à la Directive 98/37/CE - 22/06/98 et modification ultérieures. Pour vérifier la conformité aux directives susmentionnées, ont été prises en compte les normes suivantes: Normes harmonisées: EN 294 EN 349 EN 907.</p>	
<p>Stimmt mit den wesentlichen Vorschriften der Sicherheitsvorschriften und der Gesundheitsschutzvorgabe lt. EWG Richtlinie Nr. 98/37/CE - 22/06/98 und nachfolgenden Änderungsüberein. Für die Überprüfung dieser Übereinstimmungs-Erklärung lt. obigen Direktiven sind folgende Normen konsultiert worden: Normen: EN 294 EN 349 EN 907.</p>	<p>Cumple con los requisitos esenciales de Seguridad y de Preservación de la Salud contenidos en la Directiva 98/37/CE - 22/06/98 y modificaciones siguientes. Para comprobar la conformidad a la que se refieren las Directivas anteriormente citadas, se han consultado las siguientes: Normas Armonizadas: EN 294 EN 349 EN 907.</p>	
Responsabile della Sicurezza - The Security Official - Responsable Sécurité et Homologations - Der Sicherheits-Beamter - Responsable de la Seguridad		
<p>Montù Beccaria (PV) Data, Date, Datum, Fecha, _____</p>	<p>Smeraldi Paolo <i>Smeraldi Paolo</i></p>	

00102

Spray atomiser model	L qA - dB(A)
Plus 42	89,0 +- 0,2
Plus 45	92,4 +- 0,2
Plus 50	99,4 +- 0,2
Plus 55	95.4 +- 0,2
Plus 55S	95,4 +- 0,2
Plus 55E	95,4 +- 0,2

UMAPT013GB

**THE OWNER AND/OR THE OPERATOR OF THE SPRAY ATOMISER ARE NOT PERMITTED TO MODIFY THE STRUCTURE OR THE SPECIFIC OPERATION OF THE SPRAY ATOMISER ITSELF. ANY INTERVENTION NOT SPECIFICALLY AUTHORISED BY C.I.M.A. S.p.A. IMMEDIATELY VOIDS ANY KIND OF WARRANTY AND CLEARS C.I.M.A. S.p.A. OF ANY CONSEQUENT AND/OR IMPLIED RESPONSIBILITY.'**

The machines are guaranteed for **12 months** from the delivery date. During this period, spare parts not subject to wear and tear and confirmed as defective will be replaced free of charge, with the exclusion of transport and labour expenses.

The warranty will be void:

- a. should repairs be carried out without the consent of the manufacturer or one of its sale points.
- b. should original spares not be used.
- c. should the machine be used for purposes other than those for which it was specifically designed and destined.
- d. should the instructions of this manual, together with those relating to the integrative parts that make it up, not be observed.

This publication consists of 59 pages, subdivided as follows:

N° OF PAGE	REVISION	BASE
from I to VI	01	November 2000
from 1 to 53	01	November 2000

**ADDITIONAL RECORDS AND VARIANTS**

REVISION	DESCRIPTION
00	First Edition, June 2000
01	Second Edition, November 2000
02	
03	
04	
05	
06	
07	
08	

**GENERAL INDEX**

<b>1 FOREWORD</b> .....	<b>1</b>
1.1 PUBLICATION IDENTIFICATION .....	1
1.2 CONNECTED PUBLICATIONS .....	1
1.3 PURPOSE OF PUBLICATION .....	1
1.4 REFERENCE TO REGULATIONS .....	1
1.5 USING THE MANUAL .....	1
1.6 UPDATES .....	2
<b>2 GLOSSARY</b> .....	<b>3</b>
2.1 TERMINOLOGY .....	3
2.2 UNITS OF MEASURE - CODES .....	3
2.3 DECALS .....	3
<b>3 GENERAL NOTES</b> .....	<b>7</b>
3.1 MACHINE IDENTIFICATION .....	7
3.2 TECHNICAL ASSISTANCE .....	7
3.3 SAFETY INSTRUCTIONS .....	7
3.4 SAFETY SYSTEMS .....	8
3.5 MANAGING AGRO-CHEMICALS .....	9
3.5.1 STORAGE .....	9
3.5.2 SPECIFIC TOOLS .....	9
3.5.3 DISPOSAL OF EMPTY CONTAINERS AND AGRO-CHEMICAL RESIDUES .....	9
3.5.4 PERSONAL MEANS OF PROTECTION .....	10
<b>4 MACHINE STRUCTURAL ANALYSIS</b> .....	<b>11</b>
4.1 FRAME .....	12
4.2 SERVO-AMPLIFIER - FAN .....	13
4.3 HYDRAULIC CIRCUIT COMPONENTS .....	14
4.4 TECHNICAL DATA .....	21
4.4.1 Dimensions and weights of the spray atomisers .....	21
4.4.2 Technical specifications of fans - pump .....	21
<b>5 COUPLING MODALITIES</b> .....	<b>23</b>
5.1 CONNECTION TO THE TRACTOR .....	23
5.2 TRANSMISSION SHAFT ASSEMBLING .....	24
5.3 INSTALLATION OF REMOTE CONTROLS .....	24
5.3.1 Manual 2-tap distributor - P10 .....	24

**16.2 - ELECTRICAL COLLECTIONS**

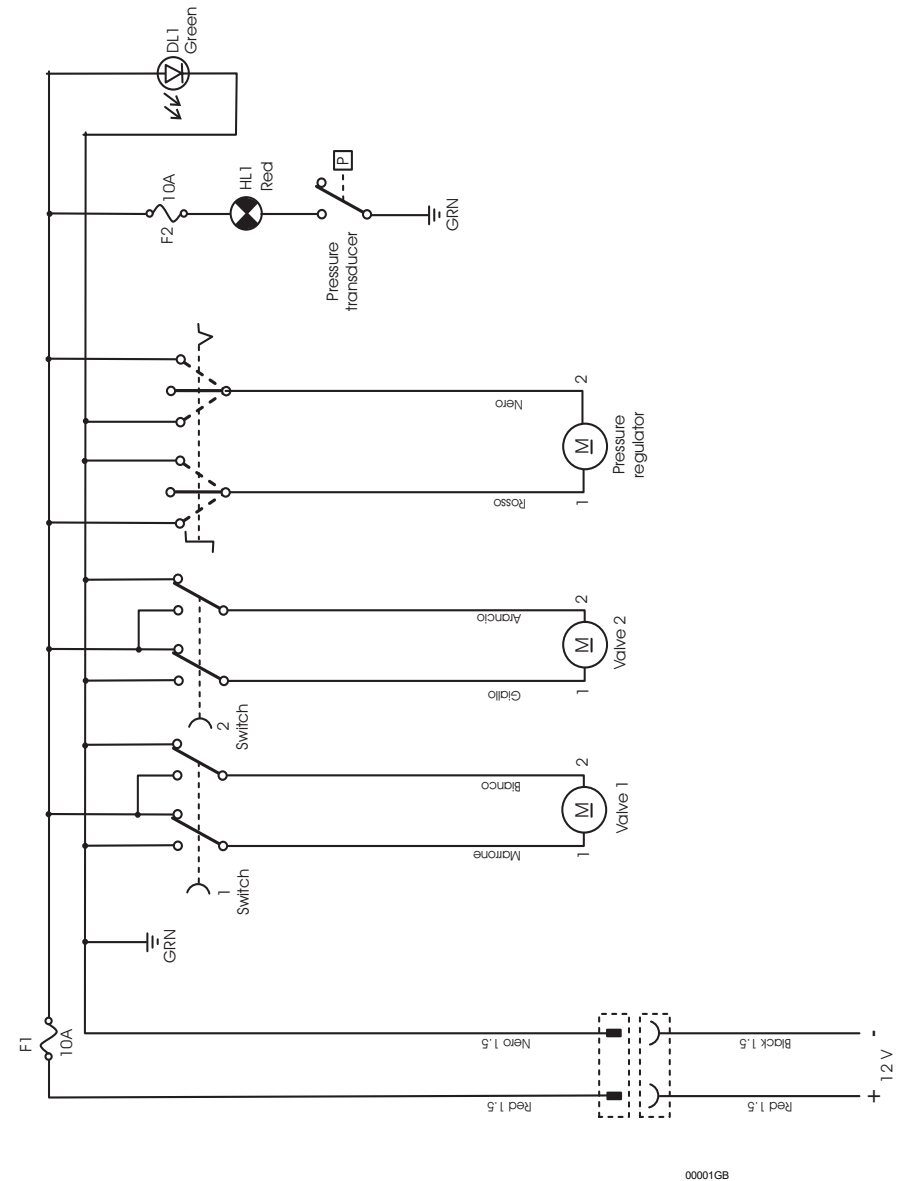

00001GB

16.1 - HYDRO-PNEUMATIC DIAGRAM

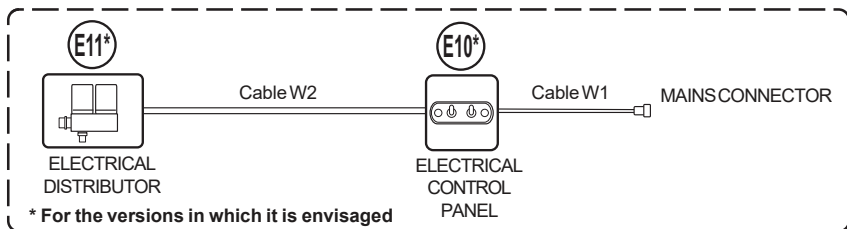
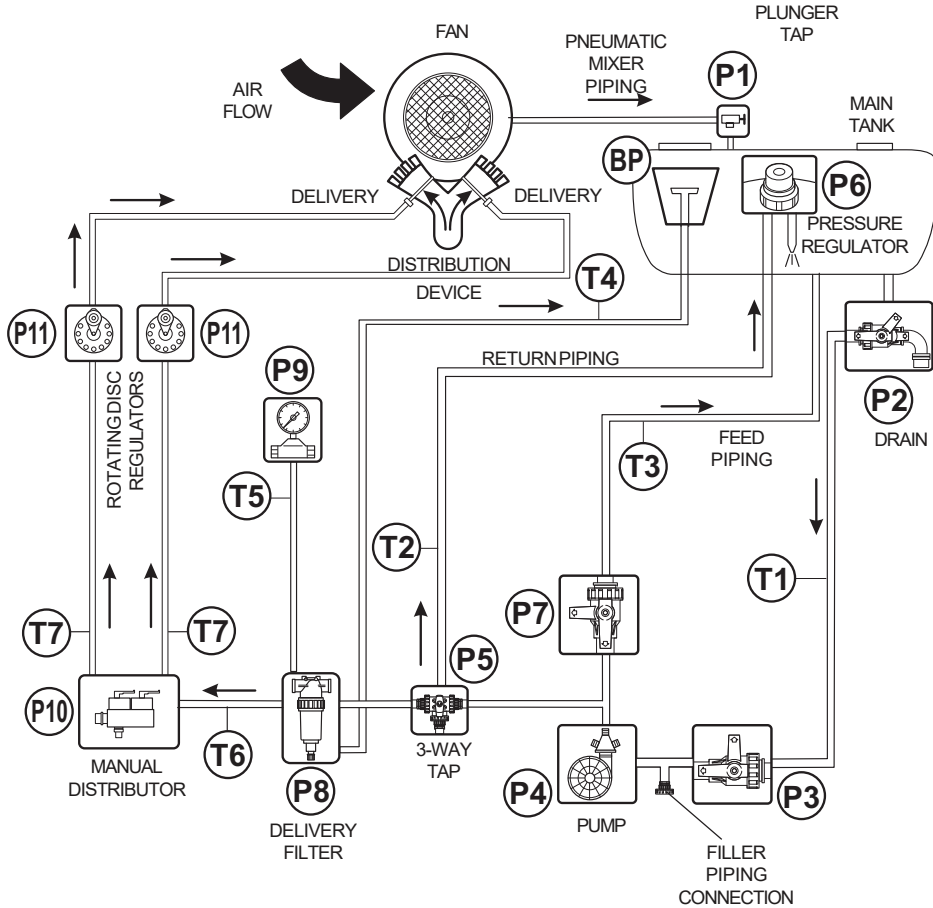

00143

5.3.2 Electrical control panel - E10 ..... 25

**6 DISTRIBUTION DEVICES ..... 26**

6. IDENTIFICATION TYPES AND CODES ..... 26

6.2 POSITIONING OF FAN-GUARD ..... 27

6.3 DISTRIBUTION DEVICES ELBOW FITTINGS ..... 27

**7 ACCESSORIES ..... 28**

7.1 FILLER PIPE ..... 28

7.2 PAIR OF WHEELS ..... 28

7.3 CRANK-CONTROLLED REVOLVING DEVICE ..... 29

7.4 ELECTRICALLY-CONTROLLED REVOLVING DEVICE ..... 29

**8 FILLING MODALITY ..... 30**

8.1 FOREWORD – USE OF THE FAN RELEASE ..... 30

8.1.a Fan release ..... 30

8.1.b Fan engagement to start the treatment ..... 31

8.2 FILLING THROUGH POURING FROM THE TOP ..... 31

8.3 FILLING THROUGH THE SPECIFIC PIPE ..... 32

**9 SHAKING OF MIXTURE ..... 35**

**10 HYDRAULIC CIRCUIT DISCHARGING ..... 36**

**11 OPERATING PROCEDURES ..... 36**

11.1 PRELIMINARY OPERATIONS TO TREATMENT ..... 36

11.2 PREPARATORY OPERATIONS TO TREATMENT ..... 36

11.3 THE TREATMENT ..... 38

11.4 END OF TREATMENT - STORAGE ..... 38

11.4.1 Daily ..... 38

11.4.2 End of seasonal cycle ..... 39

**12 LIFTING AND TRANSPORT ..... 40**

**13 MAINTENANCE OPERATIONS ..... 41**

13.1 LUBRICATION ..... 41

13.2 CLEANING OF FILTER CARTRIDGE ..... 42

13.3 PURGING OF RESIDUES FROM FILTER ..... 42

13.4 CLEANING OF THE FAN ..... 42

13.5 FAN BELT TENSIONER ..... 43

13.6	PUMP BELT TENSIONER .....	43
13.7	TANK REMOVAL OR REPLACEMENT .....	44
13.8	TABLE OF MAINTENANCE OPERATIONS .....	45
<b>14</b>	<b>FAULT FINDING .....</b>	<b>46</b>
<b>15</b>	<b>REPAIRS ALLOWED .....</b>	<b>48</b>
15.1	ASSEMBLING OF PUMP CONTROL BELT .....	48
15.2	REPLACEMENT OF ELECTRICAL PANEL FUSES .....	49
<b>16</b>	<b>INTEGRATIVE DIAGRAMS .....</b>	<b>50</b>
16.1	HYDRO-PNEUMATIC DIAGRAM .....	50
16.2	ELECTRICAL CONNECTIONS .....	51
<b>17</b>	<b>AERIAL NOISE .....</b>	<b>52</b>
<b>18</b>	<b>WARRANTY .....</b>	<b>52</b>
<b>19</b>	<b>ATTACHMENT : COMPLIANCE DECLARATION .....</b>	<b>53</b>

## 15.2. - REPLACEMENT OF THE ELECTRICAL PANEL'S FUSES



Stop the engine and remove the ignition key from the tractor's control panel.

1. Undo the fuse-carrier cover;
  2. Replace the faulty fuse and screw back the cover.
- Fuse: 1.25 A, delayed.



**ALL OTHER INTERVENTIONS MUST BE CARRIED OUT BY A C.I.M.A. SERVICE POINT.**

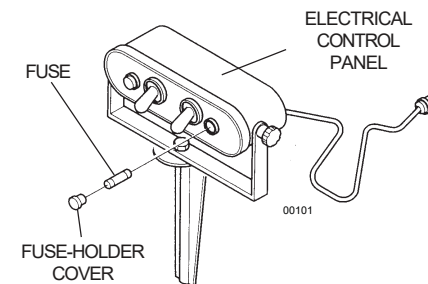





THE OWNER AND/OR THE OPERATOR OF THE SPRAY ATOMISER ARE NOT ALLOWED TO PERFORM MODIFICATIONS TO THE STRUCTURE OR OPERATION OF THE SPRAY ATOMISER. ANY INTERVENTION NOT AUTHORISED BY C.I.M.A. S.p.A. WILL FORTHWITH VOID ANY FORM OF WARRANTY AND CLEARS C.I.M.A. S.p.A. OF ANY CONSEQUENT BOND OR RESPONSIBILITY.

### 15.1 - ASSEMBLING OF THE PUMP CONTROL BELT



Stop the engine and remove the key from the tractor's control panel.

1. Remove the steel-plate guard located on the frame behind the pump, unscrewing the two securing screws.
2. Undo the spring adjustment screw of the belt-tensioner: the pump support plate will be free to rotate.
3. Open the coupling tunnel, below the 3<sup>rd</sup> connection point, rotating the mobile protection cover.
4. Insert the belt in the tank's tunnel, behind the third point. Feed the front part below the disengagement area and the rear area above, until it enters the upper pulley groove beyond the disengagement portion.
5. Insert the belt in the pump's pulley groove.
6. Reinstate the spring of the belt-tensioner according to the suggested tensioning conditions.
7. Re-assemble the steel-plate protection guards.

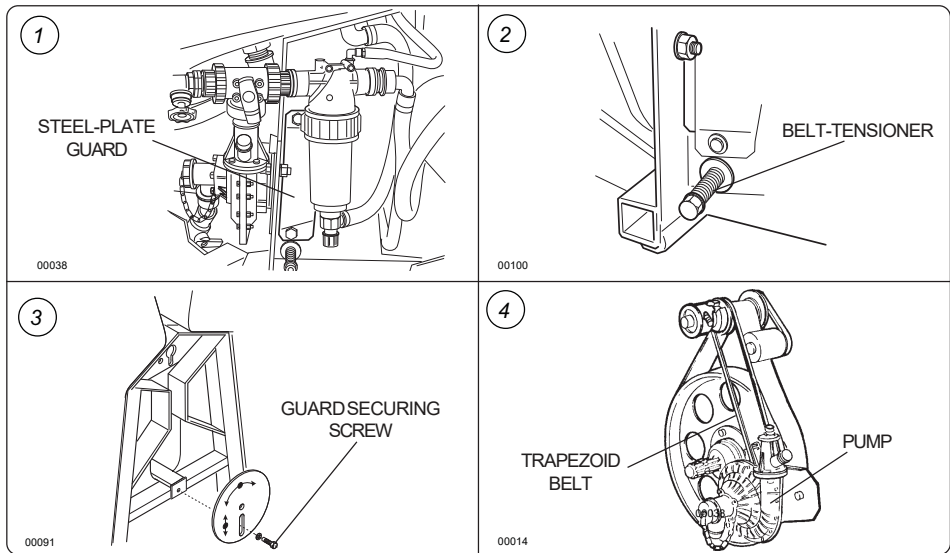

Carefully tighten the screws that were undone during the belt replacement.

### 1.1 - PUBLICATION IDENTIFICATION

The "OPERATIVE INSTRUCTIONS AND MAINTENANCE" manual is an integral part of the spray atomiser. It is identified by a Publication No. located on the third cover page, and through which the document can be identified, traced and/or subsequently referred to. The information elements contained herein are updated as at the date of publication. C.I.M.A. S.p.A. reserves the right to modify its machines without notice, with the purpose of applying technical enhancements, and it declines all responsibility for possible omissions from the publication.

### 1.2 - ATTACHED PUBLICATIONS

- Spare parts catalogue;
- Distribution devices, "Operative and maintenance instructions" for
- Distribution devices, "Spare parts catalogue"
- "Low Volume" Machine adjustment instructions"
- "Modalities for filling through the specific pipe" diagram
- "Modalities for filling through pouring from the top" diagram

### 1.3 - PURPOSE OF PUBLICATION

All indications contained in this manual are aimed at the user of the spray atomiser. The duration of the machine and its operation, the operator's safety and the respect for the environment are dependent upon scrupulous observance of the stated norms. Before making use of the spray atomiser, the user must read, understand and abide by all regulations listed in this manual.

### 1.4 - REFERENCE TO REGULATIONS

- This manual was set out conforming to the regulations contained in:
- Attachment "I" to Directive 89/392/C and subsequent modifications (letters "b", "c" of point 1.1.2 and point 1.7.4);
  - UNI EN 292/2 - 1992, point 5.5;
  - UNI EN 907 - 1997.

### 1.5 - USING THE MANUAL

Read every part of this manual, paying attention to the meaning of the **WARNING** and of **DANGER** indications contained in the text and displayed on the signs applied to the machine or on the parts that make it up. All operations suggested by the manual will have to be followed with the utmost care and only after having understood the negative consequences of their wrong interpretation and execution.

The following "symbols" are utilised within the text in order to highlight and visually identify the

importance of the various types of information:



Indicates important complementary information



The non observance of the relative indications can cause damage of an even irreparable nature to the spray atomiser.



Highlights possibly dangerous situations to persons.

The manual, with relevant attachment and possible integrating issues, must be kept with the utmost care and must always be complete, integer and legible in every part. Should it be mislaid it is imperative to immediately request a duplicate from C.I.M.A. S.p.A. Should the decals originally applied on the machine be mislaid, damaged or become incomprehensible, they should be promptly replaced.

For every type of distribution device (Head) delivered with the spray atomiser, a specific user and maintenance manual is attached. All the head manuals must always accompany the one of the machine.



- The manual must always be kept for the spray atomiser's whole operational life.
- Any modification received must be permanently inserted in this publication.
- The manual must be ceded with the spray atomiser should this be sold.

## 1.6 - UPDATES

Possible updates that C.I.M.A. S.p.A. will provide the owner of the spray atomiser will be accompanied by instructions to insert them in this publication.

Should the machine be sold, the owner must inform the new purchaser that he should notify C.I.M.A. S.p.A. of his address in order to receive possible future integrating issues and/or updates.

2

## GLOSSARY

2

2. CAUSE: the 2 drive outlets are out of alignment or are not parallel.  
**REMEDY:** Position the 2 drive outlets (PdP) correctly.

### E. FAULT: Continuous and abnormal noise level, accompanied by vibrations of fan unit.

1. CAUSE: Broken fan shaft bearings.  
**REMEDY:** Refer to the C.I.M.A. service point.

### F. FAULT: Intermittent operation of the whole distribution device

1. CAUSE: Faulty sealing of the hydraulic circuit, going from the tank's (T1) suction piping to the manual (P10) or electrical (E10) distributor.  
**REMEDY:** Carefully inspect all the points at which suction of air can take place, including as well those at which no liquid seepage is detected. Check the proper tightening of ring nuts, fittings and clamps. Check the efficiency of the sealers and the integrity of the piping. Reinstate the efficiency and replace parts that might have been found to be defective.

### G. FAULT: Intermittent spraying only on the one side of the distribution device

1. CAUSE: Faulty sealing of the hydraulic circuit going from the manual (P10) or electrical (E10) distributor to the distribution point involved.  
**REMEDY:** As per point F.1.

### H. FAULT: No pulverising action delivered: totally or only on the one side of the distribution device

1. CAUSE: Manual distributor (P10) taps dirty or clogged, or pump suction piping clogged by hardened product deposits.  
**REMEDY:** Clean.
- 1b.CAUSE: Electrical distributor (E10) taps blocked by incrustations in the closed position.  
**REMEDY:** After having lifted the lid off, turn the nut controlling the stroke of the tap.
- 2b.CAUSE: Fuses of the electrical control panel interrupted when the electrical (E10) distributor's taps are closed.  
**REMEDY:** Replace the fuses after having manually checked the solenoid valves' operation.
- 3b CAUSE: Power cable W1 of the electrical panel wrongly connected with the taps of the electrical distributor E10 in the closed position.  
**REMEDY:** Connect correctly.
4. CAUSE: Defective electrical connections.  
**REMEDY:** Refer to the C.I.M.A. service point.
5. CAUSE: Pump defective (only in case total delivery missing).  
**REMEDY:** Refer to the C.I.M.A. service point.
6. CAUSE: Broken pump belt.  
**REMEDY:** Replace the belt (See Paragraph 15.1).



**THE CAUSES AND REMEDIES FOR THE FAULTS CONCERNING THE DELIVERY OF THE PULVERISING BY ONE OR MORE DIFFUSERS ARE INDICATED IN THE USER AND MAINTENANCE MANUAL OF EVERY DISTRIBUTION DEVICE.**

**A. FAULT: By utilising the filler piping the pump doesn't operate (suction)**



**It is necessary to disengage the drive outlet (PdP) and wait for it to stop rotating before repeating the filling operation.**

- 1. CAUSE: the quantity of water poured into the tank is insufficient to trigger the pump.  
**REMEDY:** Add water to the tank until the pump starts its cycle.
- 2. CAUSE: the filler piping sucks in air.  
**REMEDY:** Completely submerge the suction filter of the filler piping.
- 3. CAUSE: Hydraulic circuit not sealing properly.  
**REMEDY:** Check the tightening of ring nuts, fittings and clamps. Check the efficiency of sealers and that piping elements are not cracked or broken. Replace parts that are possibly found to be defective.
- 4. CAUSE: Slipping of the pump's belt.  
**REMEDY:** Check the tension of the belt-tensioner's spring.
- 5. CAUSE: The pump's belt might be broken.  
**REMEDY:** Replace the belt.

**B. FAULT: Leakage and dripping from the pump**

- 1. CAUSE: Non-sealing of the fittings and clamps connecting the piping to the pump.  
**REMEDY:** Check for proper tightening of ring nuts and clamps. Check the efficiency of the sealers. Replace parts that are possibly found to be defective.
- 2. CAUSE: The sealers (O.Rings) of the external coupling flanges don't seal the pump properly.  
**REMEDY:** Refer to the C.I.M.A. service point.
- 3. CAUSE: Mechanical sealing defective.  
**REMEDY:** Refer to the C.I.M.A. service point.

**C. FAULT: Drop in pressure of the hydraulic circuit signalled by the gauge**

- 1. CAUSE: Dirty delivery filter.  
**REMEDY:** Clean the cartridge
- 2. CAUSE: Faulty sealing of the hydraulic circuit.  
**REMEDY:** Check the operation of the pump and its belt. Check the proper tightening of ring nuts, fittings and clamps. Check the efficiency of the sealers and the integrity of the piping. Replace the parts that are possibly found to be defective.
- 3. CAUSE: Centrifugal pump defective. See "B".  
**REMEDY:** As per point "B".
- 4. CAUSE: Gauge defective.  
**REMEDY:** Refer to the C.I.M.A. service point.

**D. FAULT: Vibration of fan unit**

- 1. CAUSE: Fan dirty.  
**REMEDY:** Clean. (It is advisable to refer to the C.I.M.A. service point).

**2.1 - TERMINOLOGY**

The terms FRONT, REAR, RIGHT and LEFT utilised in this publication refer to the spray atomiser as seen by an operator from behind the operative unit along the drive line and facing it: **the rear part** of the machine is that closest to the operator, and is where the distribution device (Head) is mounted - and **the front part** is the one that gets attached to the tractor.

**2.2 - ABBREVIATIONS**

g	.....	grams
g/1'	.....	revs per minute
h	.....	hour
ha	.....	hectare
ha/h	.....	hectare per hour
l	.....	litres
l/h	.....	litres per hour
l/ha	.....	litres per hectare
kg	.....	kilogram
kg/cm <sup>2</sup>	.....	kilograms per square centimetre (atmosphere)
km	.....	kilometre
km/h	.....	kilometres per hour
Lm	.....	width in metres
m	.....	metre
Mesh	.....	N° of meshes per linear inch
Micron	.....	1/1000 of millimetre
PTO	.....	power take-off
s	.....	seconds

**2.3 - DECALS**

The decals relative to the safety and the use/maintenance of the machine are applied to the machine and their meaning is described in the following paragraph.



Every decal is marked with its identification code, to be used for the necessary purchasing.

**Safety**

- 1 - 95001 - STOP THE ENGINE AND REMOVE THE KEY FROM THE TRACTOR'S CONTROL PANEL BEFORE CARRYING OUT ALL MAINTENANCE OR REPAIR OPERATIONS**  
- Positioned on the left-hand side of the tank in the forward part of the machine.
- 2 - 95004 - DANGER OF CONTAMINATION BY CONTACT OR POISONOUS PRODUCTS INHALATION**  
- Positioned above the tank, in the forward part, next to the filler spout.
- 3 - 95005 - DANGER, PARTS IN MOTION. BEFORE REMOVING PROTECTION GUARDS, STOP THE TRACTOR, REMOVE THE KEY FROM THE TRACTOR'S CONTROL PANEL AND ENSURE THAT ALL MOVING PARTS HAVE STOPPED**

- Positioned on the fan casing next to the outflow vent.
- 4 - 95015 - BEFORE UTILISING THE RELEASE DEVICE, STOP THE TRACTOR, REMOVE THE KEY FROM THE TRACTOR'S CONTROL PANEL AND ENSURE THAT THE FAN HAS STOPPED**
- Positioned on the tank in the forward part of the machine, on the mobile protection cover of the access to the release device.
- 5 - 95010 - MAXIMUM OPERATING SPEED OF THE DRIVE OUTLET (P.d.P): 540 REVS A MINUTE**
- Positioned on the forward part of the machine, on the lower part of the tank and close to the drive outlet.
- 6 - 95007 - DANGER OF SPRAYS: KEEP AT A SAFE DISTANCE**
- Positioned on the upper part of the fan casing.
- 7 - 95006 - WARNING: CONSULT THE USER AND MAINTENANCE MANUAL BEFORE USING OR INTERVENING ON THE MACHINE**
- Positioned on the left-hand side of the tank, in the forward part of the machine.
- 8 - 95009 - DANGER: GLOVES MUST BE USED TO EMPTY THE TANK**
- Positioned on the right hand side and lower part of the tank.
- 9 - 95012 - DANGER: MOUNT THE WHEELS AFTER HAVING HITCHED THE MACHINE TO THE HOISTER AND DISMANTLE THEM BEFORE UNHITCHING THE MACHINE FROM THE HOISTER**
- Positioned on the right hand side and lower part of the tank.

### Utilisation and maintenance

- 10 - 95059 - HOOKING POINT FOR THE LIFTING OF THE MACHINE**
- Positioned on the frame, above the fan's casing.
- 11 - 95052 - GREASE EVERY 20 HOURS: FAN SHAFT BEARINGS**
- Positioned on the rear of the frame, in the lower left-hand part.
- 12 - 95053 - GREASE EVERY 50 HOURS: FAN BELT-TENSIONER SUPPORT**
- Positioned on the rear of the frame, in the lower left-hand part.
- 13 - 95054 - GREASE EVERY 200 HOURS: FREE WHEEL AND WHEEL HUBS**
- Positioned on the front lower part of the tank, next to the power take-off (PTO.).
- Positioned on the wheel (accessory).
- 14 - 95067 - OIL EVERY 50 HOURS: PUMP BEARINGS**
- Positioned on the left-hand side of the machine, on the frame, behind the pump.
- 15 - 95057 - HAND WASHING TANK TAP**
- Positioned on the right-hand side of the tank, next to the tap.
- 16 - 95065 - WARNING: NEVER OPERATE THE SPRAY ATOMISER WITHOUT LIQUID IN THE TANK**
- Positioned on the forward part of the tank, above the gauge.
- 17 - 95069 - INDICATIONS FOR THE USE AND MAINTENANCE OF THE SOLENOID VALVES**
- Positioned on the tank, on the side of the electrical distributor.
- 18 - 95060 - INDICATION OF THE WHEELS OPERATING PRESSURE (ACCESSORY)**
- 95056** - Positioned on the wheel (accessory).
- 19 - 95058 - INDICATION ON THE OPERATION OF THE 3-WAY TAP (P5)**
- Positioned on the left-hand side of the tank, above the pump..

### Positioning of the safety, utilisation and maintenance decals

#### \* Safety decals

### 13.8 - MAINTENANCE OPERATIONS TABLE

CHECK	SEASON START TREATMENTS	BEFORE EVERY TREATMENT	END OF EVERY TREATMENT	SEASON-END TREATMENTS
Fan belt-tensioner spring: CHECK LENGTH 9-12cm.	YES	YES	**	**
Pump belt-tensioner spring: CHECK LENGTH 4-5cm.	YES	YES	**	**
Tank : CHECK SECURING TIE ROD AND ANCHORING BRACKET	YES	YES	**	**
Fan shaft support: GREASING	YES	**	**	YES
Fan belt-tensioner support: GREASING	**	**	**	YES
Pump bearing: OILING	**	**	**	YES
Free wheel: GREASING	**	**	**	YES
Fittings and piping: CHECK GOOD CONDITION'	YES	YES	**	YES
Clamps and fittings: CHECK PROPER TIGHTENING	YES	YES	**	**
Delivery filter: CHECK CLEANING	**	YES	YES	YES
Hydraulic circuit and tank: WASH	**	**	YES	YES
Hydraulic circuit and tank: CLEAN AND EMPTY COMPLETELY	**	**	**	YES
Tyre pressure: CHECK	YES	YES	**	**
Spray atomiser: EXTERIOR WASHING	**	**	YES	YES
Spray atomiser: STORAGE	**	**	**	YES

### 13.7 - REMOVING OR REPLACING THE TANK



This operation has to be carried out by a C.I.M.A. service point



It must in any case be performed without liquid residues in the hydraulic circuit..

1. Free the tank of its hydraulic and pneumatic connections.
2. Dismantle the mobile protection cover of the coupling.
3. Remove the tank securing bracket, undoing the 2 screws.
4. Undo the external nut (1) of the tie rod.
5. Tighten the internal nut of the tie rod, utilising the spanner provided, moving it away from the plate.
6. Undo the tie rod from its securing point, located in the rear part of the frame. Remove it through the large hole on the frame's plate.
7. Replace or reassemble the tank.
8. Re-position the tie-rod in its seat, in other words the smaller one, first inserting it through the big hole.
9. Tightly screw in and secure the tie rod to the rear plate of the frame.  
N.B. Lock tightly and with utmost care.
10. Unscrew the internal nut of the tie rod, slightly tightening it against the plate.
11. Securely tighten the external nut (1) of the tie rod against the plate.
12. Reassemble the tank's securing bracket, fastening it with the 2 screws.



Before every intervention, check the proper tightening of the 2 securing screws of the tank's mounting bracket..

13. Reassemble the mobile protection lid of the disengaging device, by securing it with the relevant screw.
14. Reinststate the hydraulic and pneumatic connections.

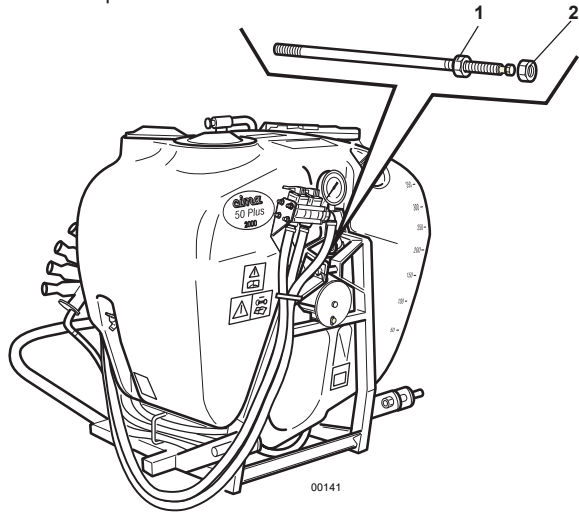

### \* Operation and maintenance decals

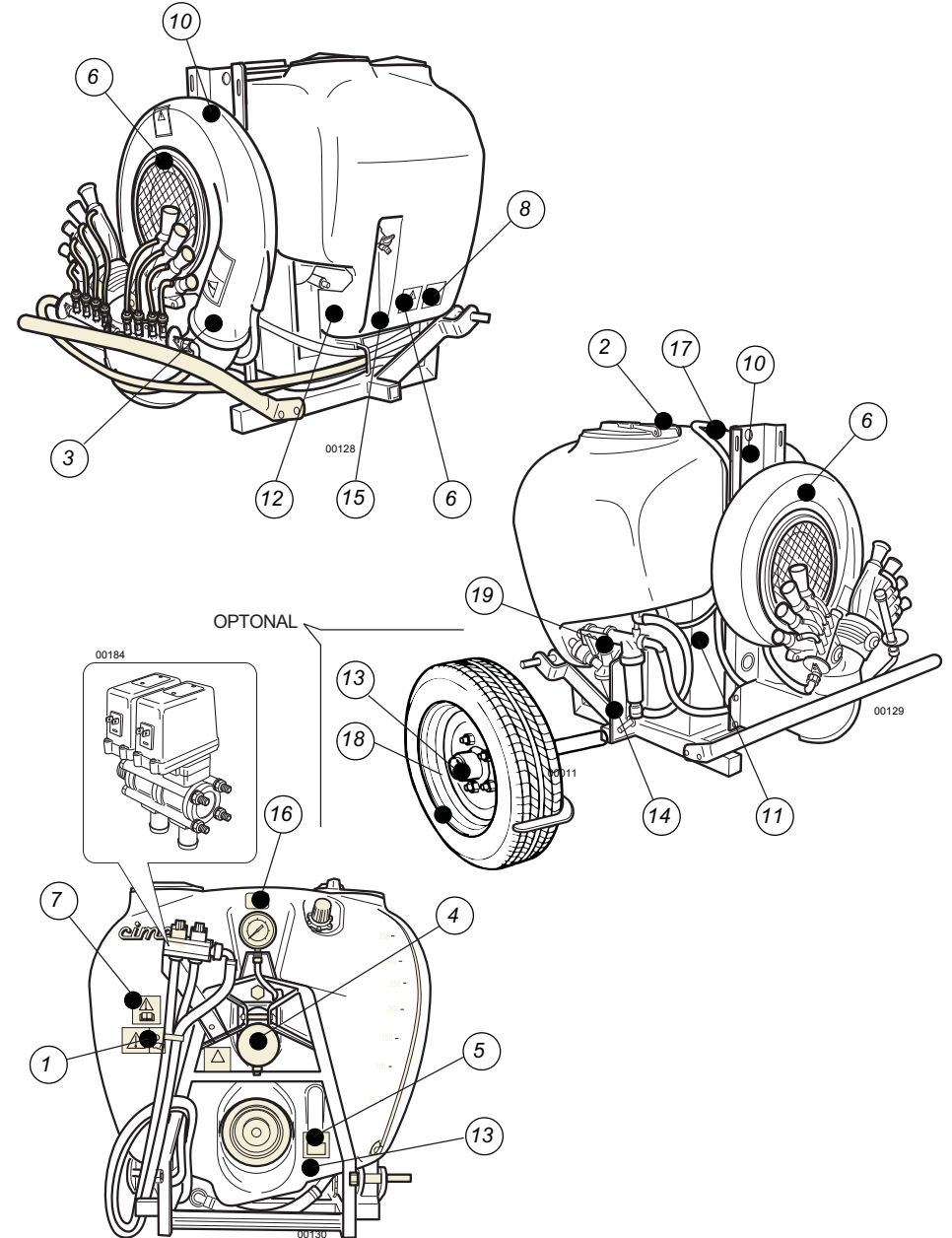

3 GENERAL INFORMATION 3



1

95001

2

95004

3

95005

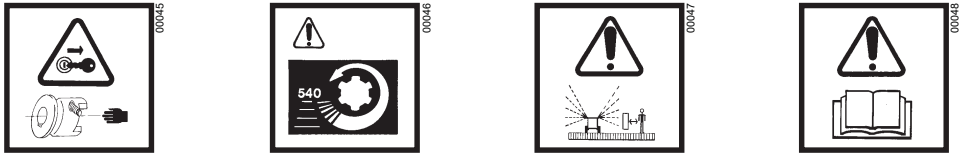

4

95015

5

95010

6

95007

7

95006



8

95009



9

95012



10 95059

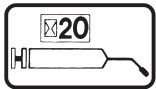

11

95052



12

95053



13

95054



14

95076



15

95057



16

95065



17

95069

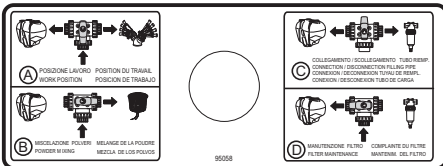

19

95058

13.5 - FAN BELT TENSIONER

Check length "L" of the spring (refer to Picture): it should be in tension between 9 and 12 cm

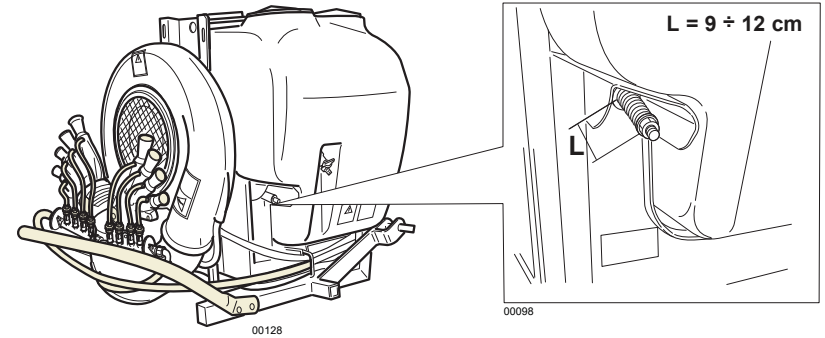

13.6 - PUMP BELT TENSIONER

Check length "L" of the spring (refer to Picture): it should be in tension between 4 and 5 cm.

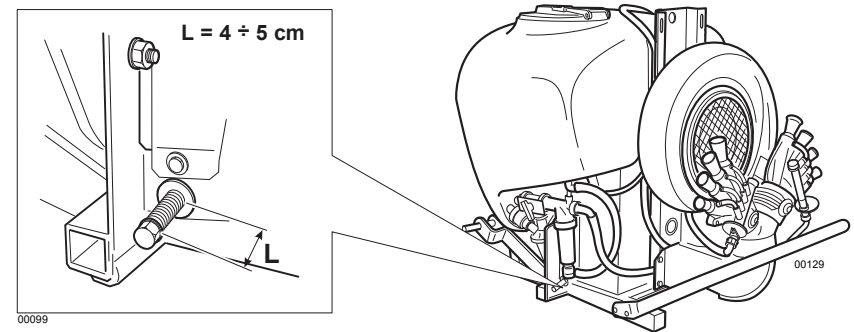

### 13.2 - CLEANING OF THE FILTER'S CARTRIDGE

1. Set the lever of 3-way tap (P5) to the "d" position
2. Close the manual distributor's taps (P10), or electrical (E10).
3. Undo the thumb screw and remove the body of the filter.
4. Extract the cartridge: clean the grill and the retaining "O" Ring.
5. Reassemble the cartridge and secure the lid with the thumb screw. Pay attention to the assembling of the lid's "O" Ring as the incorrect sealing of the filter will jeopardise the proper operation of the spray atomiser and cause loss of the mixture.

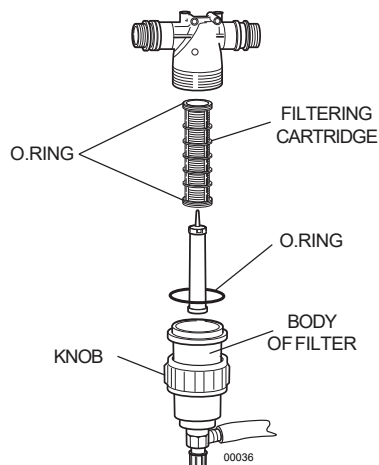

### 13.3 - PURGING OF THE FILTER RESIDUES

With the machine in operation and the taps of the manual (P10) or electrical (E10) distributor closed. Opening the tap below the lid (P8) (turn the knob anticlockwise), the delivery flow will drag possible sludge to the bottom of the filter within the tank through the piping (T4) thus partially cleaning the filtering cartridge. Close the tap when the operation is completed.



**When the machine is in operation, check that the drain tap is closed before opening the main feeder.**

### 13.4 - CLEANING OF THE FAN



**It is advisable for the cleaning of the fan to be carried out at a C.I.M.A service point. Dirt accumulation or incrustations can unbalance the fan, inducing vibrations that could cause breakage**

1. Remove the distribution device (head) and the relative elbow fitting.
2. Unscrew the two nuts securing the collar.
3. Remove the collar locking the fan's casing to the rear cover.
4. Dismantle the fan casing.



**The fan itself must not be dismantled..**

5. Clean the fan avoiding the use of high-pressure water jets: these could cause infiltration within the fan shaft's support and damage the bearings.
6. Reassemble the casing paying particular attention to the perfect coupling with the rear cover.

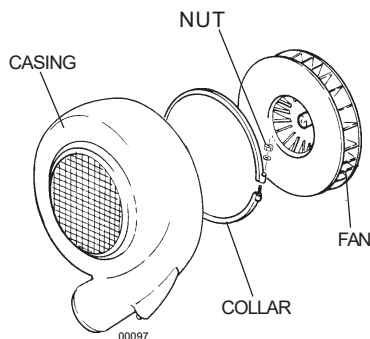

### 3.1 - IDENTIFICATION OF THE MACHINE

### 3.2 - TECHNICAL ASSISTANCE

C.I.M.A. S.p.A. is at the complete disposal of customers for any type of intervention. The names and addresses of its service network, both in Italy and in foreign countries, can be requested from:



00070 Identification nameplate

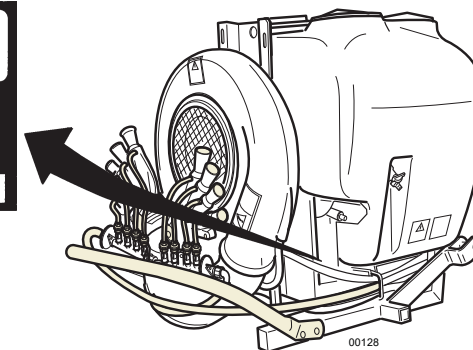

**C.I.M.A. S.p.A. - 27040 Montù Beccaria - Loc. Molino Quaroni (PV) - ITALIA**  
 tel. 0385-246636 - fax 0385-246637  
 dall'estero tel. +39-0385-246636 - fax +39-0385-246637  
 e.mail [tecnico@cimaitalia.com](mailto:tecnico@cimaitalia.com)

### 3.3 - SAFETY NOTICES

All the preparation, utilisation, maintenance, moving and transporting operations must be carried out only after having acquired a perfect knowledge of the regulations contained in this publication and the ability to appropriately interpret the symbols of the decals applied to the machine.



**IT IS FORBIDDEN TO UTILISE THE SPRAY ATOMISER FOR PURPOSES OTHER THAN FOR ITS INTENDED USE, SINCE IT WAS MANUFACTURED ONLY FOR DUSTING AGRICULTURAL CROPS WITH ANTI-PARASITIC PRODUCTS.**

It is necessary to scrupulously abide by the following general norms:

- always stop the tractor's engine before carrying out any operation on the spray atomiser;
- check that the weight and power of the tractor are compatible with the spray atomiser to be deployed;
- before utilisation, check the correct tightening and securing of the machine's various components, paying particular attention to the safety protections and to the moving parts;
- only utilise protected drive couplings provided with CE conformity certification. Carry out the assembly only if the drive outlets of both tractor and spray atomiser are equipped with the protection counter-guard;
- check that the drive coupling is blocked by the appropriate anti-rotation chains;
- keep people and animals away from the machine before starting it up;
- don't wear articles of clothing that might get caught in moving parts;
- keep to a low speed while negotiating humps or crossing ditches.



- All maintenance and repair operations must be carried out only after having washed the hydraulic circuit with clean water.
- Before operating within the tank it is necessary to wash it thoroughly with clean water.
- It is forbidden to perform welding operations if ammonium salts were previously used.
- It is forbidden to use the machine within a potentially explosive environment.
- The application of paints and/or solvents, the washing of closed environments and machinery as well as the utilisation of the air flow for purposes other than those expressly concerning the spraying of agro-chemicals are not permitted.
- It is forbidden to enter the tank.

### 3.4 - SAFETY SYSTEMS

All machine moving parts are suitably protected by guards and highlighted through the use of warning decals.



- It is forbidden to use the machine with these guards removed.
- Before removing the protection, stop the tractor's engine and remove the key from the control panel.

The Pictures illustrate the machine's guarded parts:

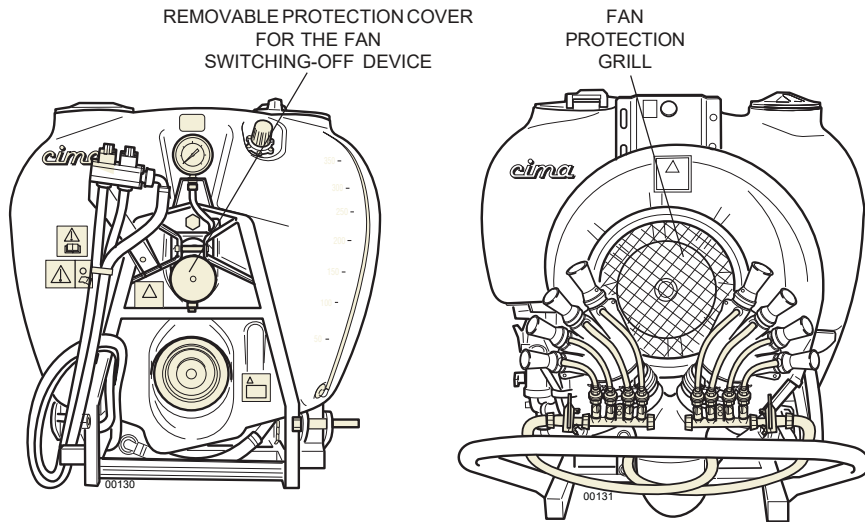

THE OWNER AND/OR THE OPERATOR OF THE SPRAY ATOMISER ARE NOT PERMITTED TO MODIFY THE STRUCTURE OR THE SPECIFIC OPERATION OF THE SPRAY ATOMISER ITSELF. ANY INTERVENTION NOT SPECIFICALLY AUTHORISED BY C.I.M.A. S.p.A. IMMEDIATELY VOIDS ANY KIND OF WARRANTY AND CLEARS C.I.M.A. S.p.A. OF ANY CONSEQUENT AND/OR IMPLIED RESPONSIBILITY.



ALL OPERATIONS MUST BE CARRIED OUT WITH THE ENGINE SWITCHED OFF AND WITH THE IGNITION KEY REMOVED FROM THE CONTROL PANEL.

### 13.1 - LUBRICATION

Maintenance point	Action	Consumption material	Periodicity
Fan shaft bearing support	Greasing	Grease type EP Classe NLGI 2	20 hours
Fan belt-tensioner support	Greasing	Grease type EP Classe NLGI 2	50 hours
Pump bearings	Oiling	Motor oil	50 hours
Free wheel	Greasing	Grease type EP Classe NLGI 2	200 hours



- Carefully clean the greasing nipples and the oil filler in order to avoid that, during lubrication, dirt might be introduced.
- In case of intensive machine usage, reduce lubrication times accordingly.

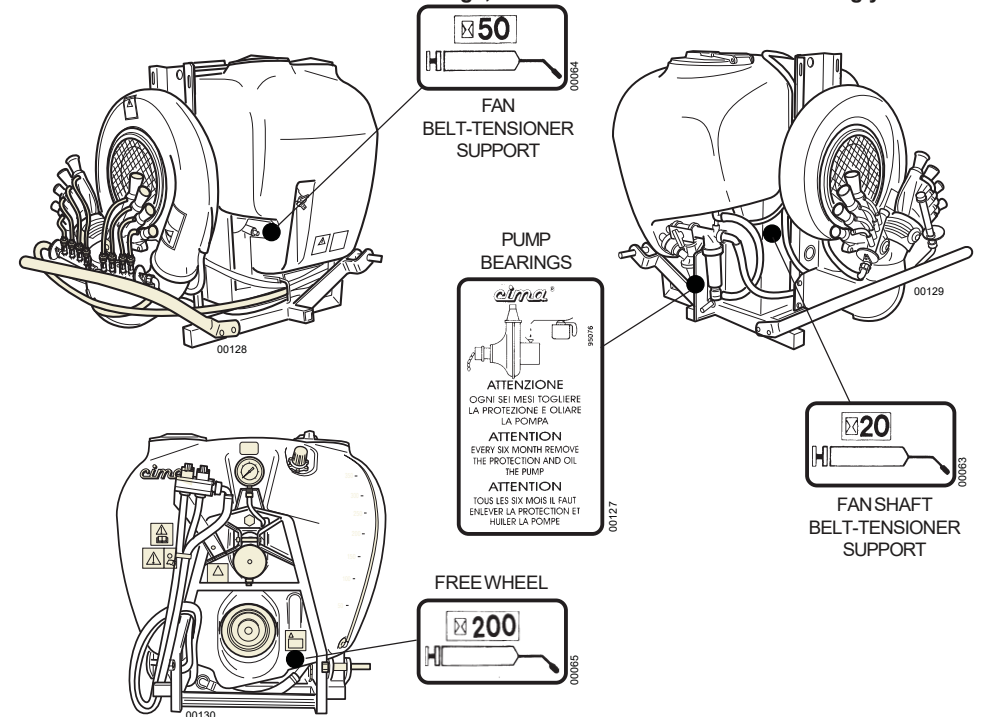



12 HOISTING AND TRANSPORTATION 12



**THE FOLLOWING ACTIONS ARE NOT ALLOWED:**

- Transporting or hoisting the spray atomiser with residual quantities of mixture in the tank for purposes differing from its destined usage.
- The transporting of persons, animals or things.
- The trailing of vehicles or equipment.



Road transport must take place in the complete observance of road regulations in force in the Country where the machine is deployed.

- When the footprint of the spray atomiser exceeds that of the tractor, the specific notice sign for overhanging loads needs to be attached on the rear.
- It is necessary to replicate the tractor's number plate and tail lights when these are covered by the machine.

The operator is responsible for possible defaults due to the non observance of said regulations.

• Hoisting and transportation of the spray atomiser



Before carrying out any operation it is essential to verify that no mixture residues are left in the tank.

1. Check that the cables or chains utilised for the hoisting are adequate for the weight to be lifted (machine – distribution devices - accessories).
2. Hook the machine through the specific support point indicated by the specific decal on the frame, checking all the parts involved in the operation.
3. Lift the machine, verifying that it is properly balanced.

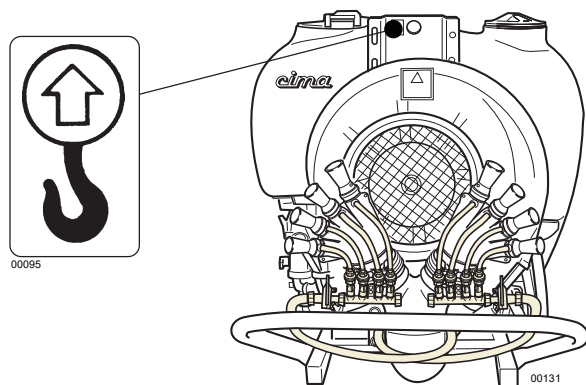

4. Position the spray atomiser on the transporting vehicle in perfectly stable conditions.
5. During transportation the machine must be immobilised and fastened to the carrier by way of suitable strapping.

3.5 - HANDLING OF AGRO-CHEMICALS

The **operator** could become contaminated due to accidental sprays, contact or inhalation of products or crop-dusting mixtures.

The **environment** could become polluted by mixture over-spills, puncturing of containers, uncontrolled storage of used and unwashed containers or spillage into waterworks.

In order to avoid these risks the preparation and filling operations must be carried out in suitably appointed and adequately equipped sites.

3.5.1 - Storage

**Fixed / stationary:** the site used must be well ventilated and secured by lockable doors in order to prevent even accidental access by children or unauthorised persons.

**Mobile:** the carrier equipment must be properly lockable and kept under conditions whereby access by children or unauthorised persons can be prevented during the absence of the operator. All full or partially utilised containers must be secured against tipping, falling or breakage during transportation.

Both types of storage must:

- have a suitable container for the storing of empty packaging materials should a specific storage area not be available;
- have a clean water supply readily available for washing, by means of a specific container or through connection to the waterworks system;
- have the use of fire extinguishers, should flammable products and substances be stored..



- All packages, whether whole or partially utilised, must be stored in their original packing and with the warning instructions clearly displayed and legible.
- The storage indications must always be scrupulously adhered to, as well as their utilisation and possible disposal as suggested on the product's original packaging.

3.5.2 - Specific equipment

The site at which the preparation and filling out will take place must provide for:

- all the equipment necessary to the precise measuring of both the water quantity and the dose of product to be mixed in the tank at every filling;
- all the equipment and means useful to the preparation of the mixture and for the cleaning of the operator in case of contamination;
- all tools necessary to facilitate the direct introduction of the agro-chemicals in the tank;
- the allocation of clothing and specific equipment in order to avoid contamination by contact or inhalation during the whole operative phase of the intervention;
- the availability of proper equipment able to stop the uncontrolled spilling and flowing of the mixture;
- a retaining valve on the feed pipe when the filling of the tank takes place directly from the waterworks system.

3.5.3 - Disposal of empty containers and agro-chemicals residues

Agro-chemicals are classified as "special" waste and their disposal must take place separately from "urban" wastes.



**Empty packaging and contaminated containers to be done away with cannot be dispersed, burned or buried.**  
**The washing water for the cisterns and the tools utilised for the preparation of mixtures cannot be emptied on the ground, spilled into the sewerage system or in water courses and rivers.**

The disposal of special wastes is regulated by specific norms. In order to perform this operation it is necessary to obtain the relevant information from the Local Offices specifically appointed to rule on this subject. The non compliance with these regulations can cause considerable damage to persons and animals as well as polluting the environment.

### 3.5.4 - Personal means of protection

The toxicity of agro-chemicals forces persons working with them to wear adequate protective clothing and accessories in order to avoid risks of contamination by contact or inhalation.

In each of the following work stages:

- filling of tanks and adding of the agro-chemical,
- dusting and spraying,
- adjusting of the spray atomiser,
- emptying and cleaning of the tank,
- replacement of the agro-chemical,
- maintenance interventions,

it is necessary to wear personal protection clothing and accessories.

The following must be worn:

- Polyethylene or polyvinyl gloves.
- Full, waterproof cotton overalls, in order to guarantee transpiration, fitted with polypropylene side flaps.  
 In commerce, one-time 'tyvek' overalls are available which, after use (see Picture), must be disposed of according to the modalities applicable to toxic waste.
- A protective half-mask in polychloroprene rubber with 1 or 2 filters. Filters for gasses and organic fumes, of European A1-class vapours, are envisaged and these can be combined with anti-dust models of P1 European class, for harmful mists and powders, or P2, for harmful and toxic mists and powders.

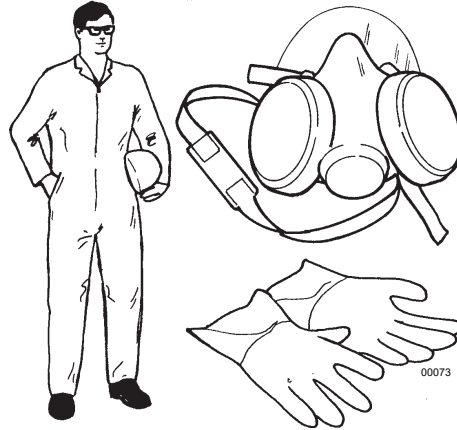

**The filters must be replaced:**

- when the smell/taste of agro-chemicals can be detected, and that of active A1-class carbons;
- when difficulty in breathing is experienced for the anti-dust filters of class P1 and P2.

**In any case it is necessary to make use of all personal means of protection as suggested by the manufacturers.**

- c. Check the efficiency of the distribution device (head) and the cleaning of the pulverising points (diffusers), possibly replacing them if found to be damaged.
- d. Clean out the filter cartridge.
- e. Keep the machine in a ventilated place, sheltered from rain or sun: sunrays are the worst enemies of plastic and rubber parts.

### 11.4.2 - End of seasonal cycle

• **The operator must:**

- a. Take the utmost care in carrying out the operations envisaged at the end of the daily treatments: the cleaning of the hydraulic circuit must be done at least twice. Check that no product residues are left in any part of the circuit.
- b. Apply suitable lubrication to all greasing points, then operate the spray atomiser for a few minutes.
- c. Empty the hydraulic circuit completely, with particular attention to the centrifugal pump.



**Avoid using anti-freeze solutions.**

- d. Check the proper operation of all parts and of the machine structure. In case of faults being detected, request the intervention of one of our service points.
- e. Keep the machine in a well ventilated place, sheltered from rain, icing and direct sun rays.



**The use of detergent products for the cleaning operations is allowed only in the observance of the regulations in force. For these, the operator must gather the relevant information from the specifically appointed bodies ruling on this subject.**

## 11.3 - THE TREATMENT



IT IS ADVISABLE TO BEGIN TREATMENT AT THE HEADLANDS..

- **The operator must:**
  - a. shake the mixture in the tank before starting the treatment, re-circulating it completely for as long as it takes to make it homogeneous.
  - b. continue to shake the mixture until the treatment is resumed should the intervention momentarily be interrupted. If the utilisation is to be deferred, check that the filter cartridge is clean before resuming and shake the mixture that has remained in the tank.
  - c. ensure that the hand wash supplementary tank is filled with clean water after each filling operation.
  - d. make use of individual protections identical to those envisaged for the preparation of mixtures if the tractor is not equipped with a pressurised cabin with aeration filters.
  - e. wash immediately all the elements that might have become contaminated during the treatment, promptly remove the polluted garments and **interrupt the work if these cannot be immediately replaced.**
  - g. keep to the preliminary operations already indicated (11.1.c), in case of wind conditions prevailing.
  - h. stop the engine, remove the key from the tractor's control panel and lower the hoist during stoppages.
  - i. pay particular attention to the treatment when close to boundaries and in proximity of dwellings, water courses, roads or public-usage paths.

## 11.4 - END OF TREATMENT - STORING

### 11.4.1 - Daily

- **The operator must:**
  - a. Wash the machine's exterior before cleaning out the hydraulic circuit. The operative sequence will permit the elimination of possible water residues from the fan casing and piping conveying the air flow to the heads.



**The washing of the spray atomiser's exterior must be carried out in an area in which foul waters are collected in a disposal pit. DO NOT UTILISE HIGH-PRESSURE HYDRO-CLEANERS.**

- b. Carry out the cleaning of the hydraulic circuit by washing the inner side of the tank with a clean water jet, then spraying it on the crop on which the treatment has just been completed: if necessary repeat this operation.

## 4 MACHINE'S STRUCTURAL ANALYSIS 4

The pictures indicate the position of the main components of the spray atomiser.

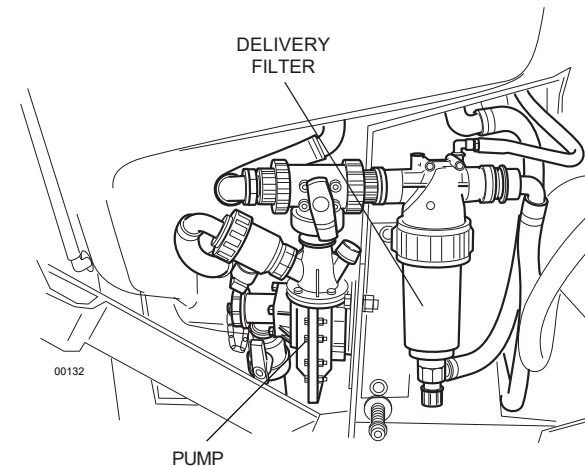
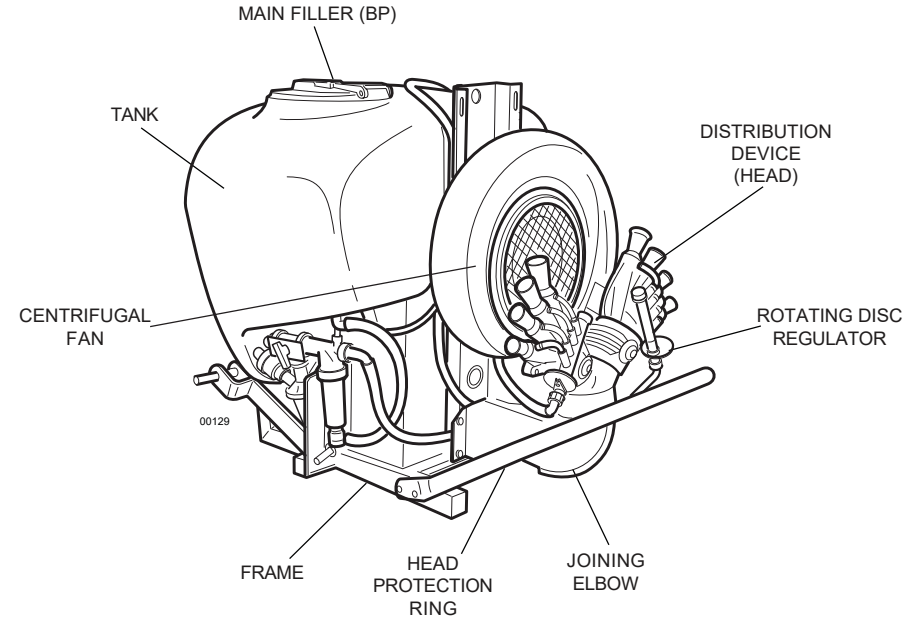

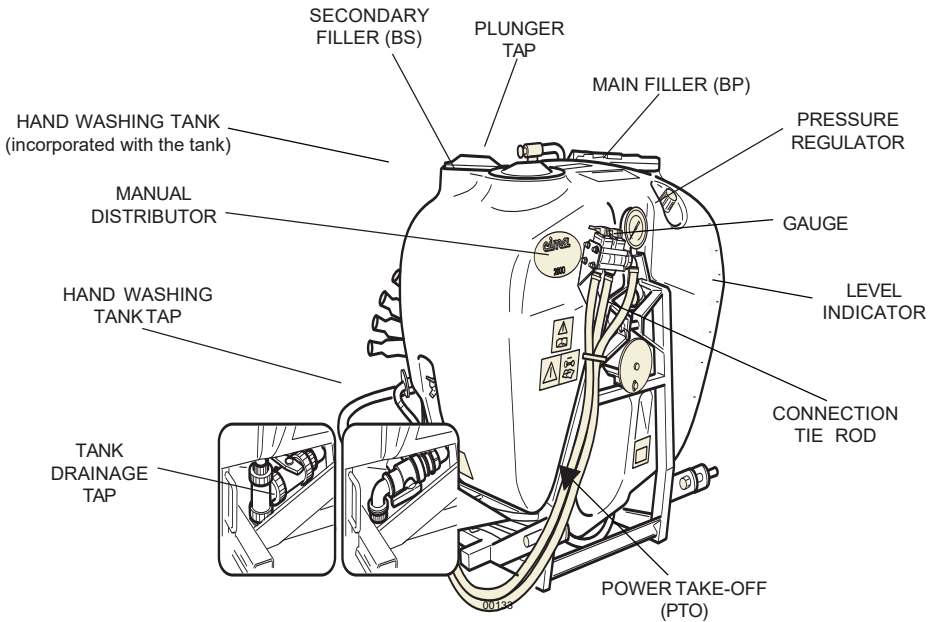

#### 4.1 - FRAME

Frames of series Plus 42 and 45 can be coupled to category “1” hydraulic hoists. The plugs diameter is 22 mm. The diameter of the third-point plug is 19 mm.

Frames of series Plus 50, 55, 55S and 55E can be coupled to category “2” hydraulic hoists. The plugs diameter is 28.5 mm. The diameter of the third-point plug is 25 mm.



**In order to limit the shifting of the centre of gravity and to implement a functional coupling, ALL frames allow for the double positioning of plugs**

- The tank-securing bracket is mounted by means of 2 screws on the front, below the 3<sup>rd</sup> point.
- A tie-rod through the tank’s upper tunnel connects the front part of the frame to the rear. This must be dismantled should the tank be removed and it must be repositioned after having re-assembled the tank.  
This operation is carried out from the front, below the 3<sup>rd</sup> point connection, by means of a spanner supplied with the machine.
- In the forward part, below the 3<sup>rd</sup> point connection, the removable protection cover of the fan release device is secured by means of a screw.

The application of a ring onto the frames in order to protect the distribution devices is envisaged. This must be mounted in the most effective position, according to the operating conditions and in keeping with the type of heads utilised.

A chain with hooks, fixed to the front part of the frame, allows the support of the transmission joint when the machine is coupled to the tractor.

All frames are pre-set with axles for the application, on request, of a pair of wheels (please refer to the installation accessories for the assembly, Paragraph 7.2).

**The operator must:**

- a. Wear adequate protective clothing and accessories such as overalls, waterproof suits, gloves, glasses and masks to shield him from contamination by inhalation or contact with the products handled.



- Anti-dust masks don't offer any protection against toxic vapours.
- Avoid wearing loose clothes that might entangle with moving parts.

- b. Check that the filters are clean and perform the checking and maintenance operations necessary to the correct setting of the machine.
- c. With the parameters defined during the preliminary operations, carry out the adjustments of the spray atomiser.
- d. Prepare the mixtures in a well ventilated area. When in the open, the presence of wind increases the danger of contamination.
- e. Precisely weigh the previously calculated doses of products to be mixed at every filling operation.
- f. Avoid handling products close to open flames, embers, incandescent bodies or in the presence of flammable substances.
- g. In order to obtain the correct volume dosage of agro-chemicals and fertiliser mixtures, the fertiliser must be first diluted.
- h. Wash and rinse the just emptied product containers with clean water – collect the washing water and pour it in the tank before carrying out the filling – place the empty packaging in the specific container or in the collection area.
- i. Wash the equipment and tools utilised in the preparation and place them in the chemical products storage area.
- l. **Always** leave the area assigned to the loading and preparation of the mixtures in such condition as to avoid any possibility of contamination to persons or animals or of pollution to the environment.
- m. Having completed the filling of the machine, suitably fill the tank used for personal cleansing with clean water.
- n. if necessary, mark the field or the area of machine passes in order to provide a guide for the treatment and avoid missing or double-treating coverage areas.



- **AT THE END OF THE OPERATIONS NECESSARY FOR CARRYING OUT THE INTERVENTION, THE LOCATION-STORAGE AREAS MUST BE LEFT IN THE CONDITION REQUIRED FOR THE CARRYING OUT OF THEIR PREVENTION AND PROTECTION FUNCTIONS.**
- **BEFORE STARTING THE TRACTOR, KEEP AWAY PERSONS OR ANIMALS AND NEVER LEAVE IT UNATTENDED DURING THE PREPARATION OPERATION.**

### 11.1 - OPERATIONS PRELIMINARY TO THE TREATMENT

- The operator must:
  - a. Ascertain that the condition of the crops, the progress of the disease or the need for its prevention actually justify the treatment to be applied.
  - b. Be aware of the meteorological conditions forecast for all the time necessary for carrying out the treatment.
  - c. If possible, avoid carrying out the spraying in strong wind conditions or when one detects that the sprayed mixture disperses away from the target crop (drifting). It is advisable to suspend the treatment when the wind speed exceeds 3 m/s (10 km/hour). Should it be imperative to operate anyway, the following suggestions are made:
    - reduce the distance of the target from the spraying points, even if detrimental to the quality of the pulverising
    - increase the dimension of the droplets, suitably adjusting the machine.
  - d. Check that multiple-product mixtures be physically, chemically and biologically compatible amongst themselves; if need be, obtain the necessary information from the products' sales representative.
  - e. Carefully calculate the exact quantity of the product necessary for the treatment and establish the volume of water to be used for the intervention.
  - f. Check that the product is available in a quantity sufficient to complete the intervention.
  - g. Read the product's utilisation instructions carefully, in order to ascertain the usage conditions, the correct dosage and the expiry dates.
  - h. Make sure of the parameters necessary to the adjustments of the machine and determine the exact dose of product to be applied to every loading. Follow the instructions of the publication titled "Instructions for the machine's adjustments – Suggestions and considerations on the low-volume treatments" as well as those contained in the use and maintenance booklet of the distribution device.

### 11.2 - OPERATIONS IN PREPARATION OF THE TREATMENT



**THE FILLING MUST BE CARRIED OUT WITH THE MACHINE ON A FLAT SURFACE. BEFORE THE OPERATION, IN THE ALLOCATED AREA, THE DOSES OR MIXTURES TO BE Poured IN THE TANK MUST BE MADE READY.**

Before starting the filling cycle, check:

- the EFFICIENCY of the Distribution device (HEAD);
- that the PULVERISING POINTS (DIFFUSERS) ARE CLEAN;
- that the CARTRIDGE AND THE DELIVERY FILTER (P8) ARE CLEAN;

### 4.2 - FAN SERVO AMPLIFIER

#### Servo amplifier

A free-wheeling gear is included between the Power Take-off of the servo amplifier and the fan control pulley (refer to the Picture).

In case of sudden decelerations or unexpected engine Stoppages, this allows the fan to continue its free rotation, thus avoiding extreme mechanical stresses to be transmitted to the drive members..

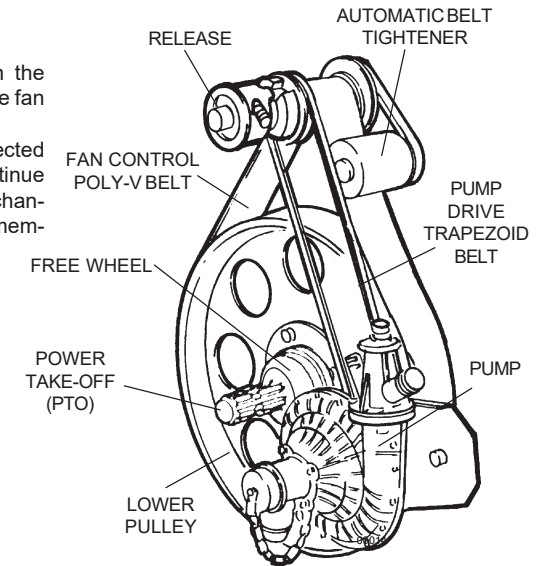

#### Centrifugal fan

The front-engaging clutch assembled on the fans shaft allows the operating of the centrifugal pump by excluding that of the fan.

The fan housing can rotate by 360 degrees. This permits the positioning of the outlet spout at the point necessary for the assembling of the different distribution devices.

An air intake, pre-set on the outer edge of the housing, is connected to the plunger tap placed above the tank. Through this tap it is possible to carry out or exclude the pneumatic shaking of the mixture. The centrifugal close-propellers fan is built out of steel plate; the air intake on the housing is protected by an apposite grill.

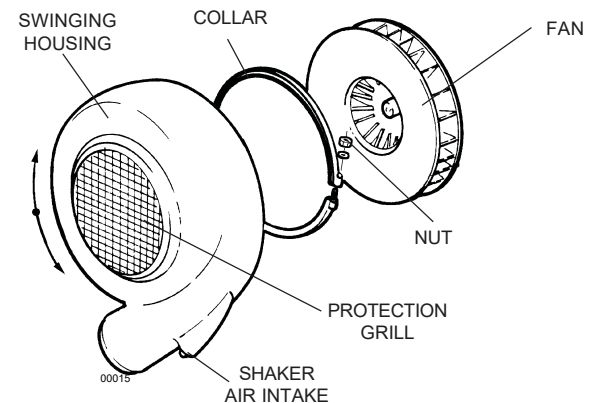

### 4.3 – HYDRAULIC CIRCUIT COMPONENTS

**LEGEND:**  
 P - E = elements of the circuit  
 T = piping

*\*For versions in which this is envisaged*

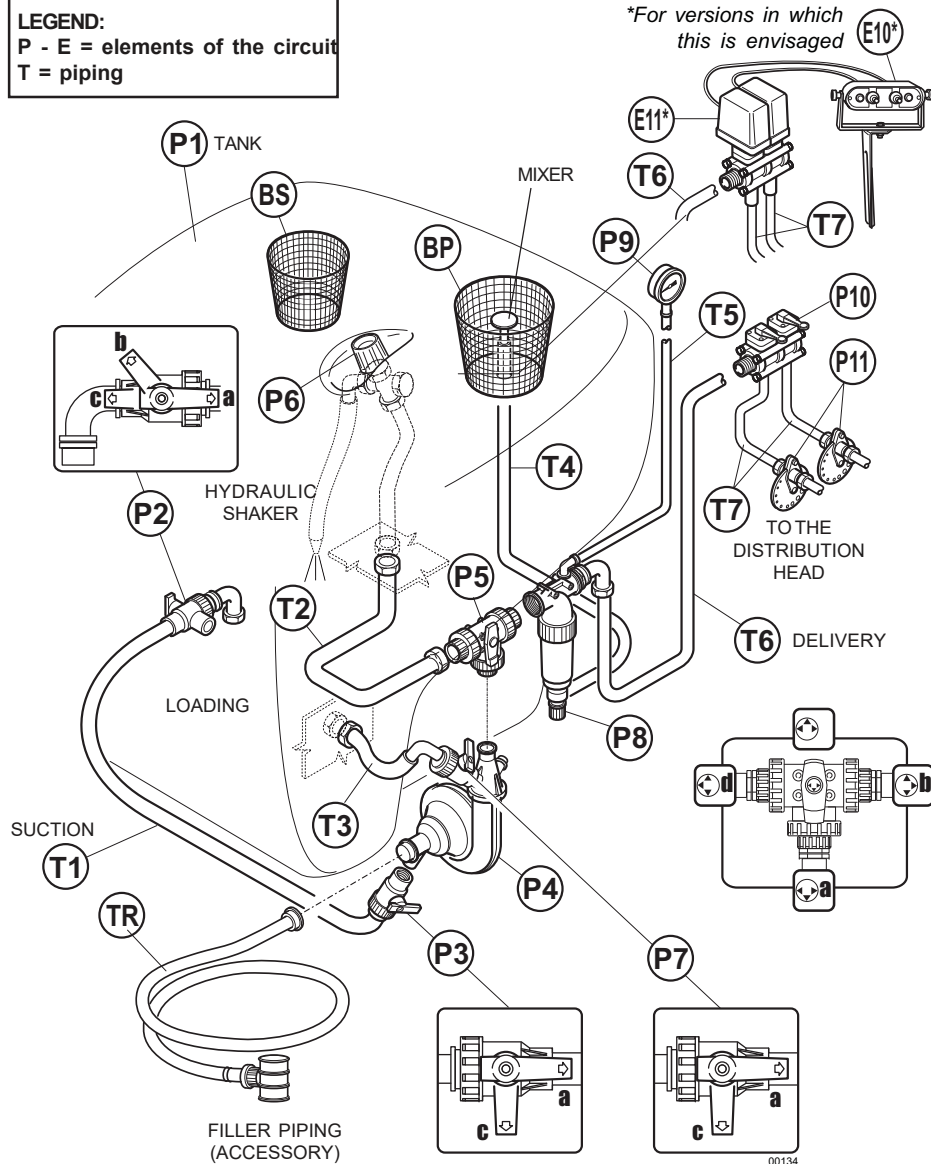

Hydraulic connections diagram

### 9 SHAKING OF THE MIXTURE 9

The hydraulic and pneumatic circuits assembled within the tank provide a double system for shaking the mixture: through the water from the pump and by means of the air from the fan, simultaneously. The pneumatic shaking can be excluded when products causing excessive foaming are used. In this case it is sufficient to close the plunger tap located above the tank. When it is reopened, check that the air outlet holes are not blocked.



Before starting the treatment it is essential to shake the mixture in the tank, recirculating it completely for as long as it takes to make it homogeneous.



The shaking action must be carried out with the pressure regulator (P6) open in case of first utilisation of the machine, or in the position already selected for the treatment in progress or for the preceding one. The plunger tap above the tank must also be open if the treatments involved don't use agro-chemicals generating excessive foam. This operation is of essential importance in obtaining a uniform distribution of the chemical's active agent over the whole crop to be treated.

Should the activity need to be interrupted during a treatment with the spray atomiser, keep the shaking activated until the treatment is resumed. Should this be stopped and deferred to a later stage, the mixture that has remained in the tank must be shaken again properly.

### 10 DISCHARGING OF THE HYDRAULIC CIRCUIT 10



- Stop the tractor and remove the key from the control panel.
- Wear suitable protective clothing and accessories in order to avoid contamination by contact or inhalation of the mixture.
- Carry out the discharging in a suitable and properly geared area for the collection of the washing liquid..

The operation is carried out through the drain plug P2:

1. Unscrew the drain plug only when the tap's lever is in the "a" position. (Drain closed).
2. Turn the lever to position "b". (Drain open)..

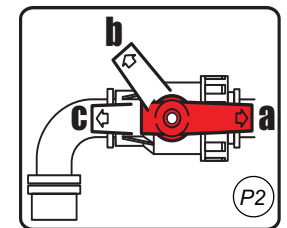
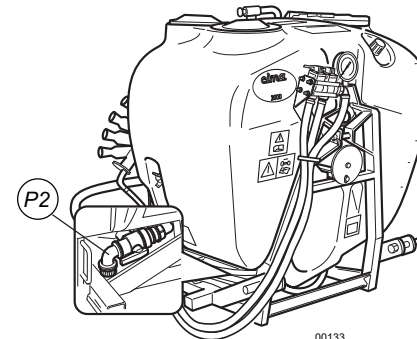

00033

00133

16. Lift the machine. Activate the drive outlet (P.d.P.) and keeping it at 500 revs/min, perform a further shaking cycle.  
CARRY OUT THE TREATMENT.

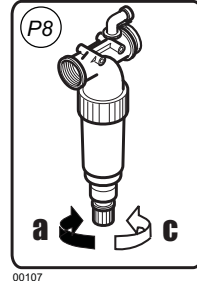
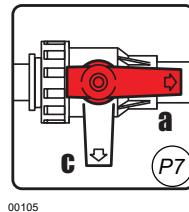
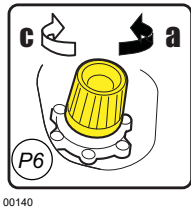
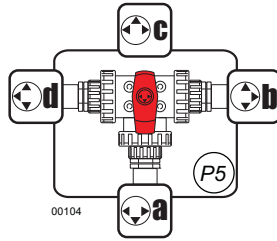
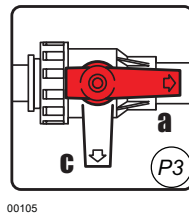
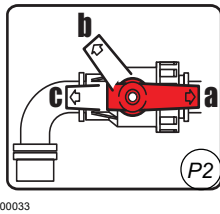
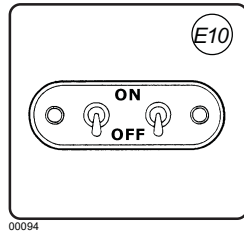
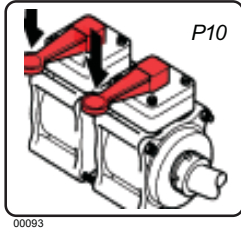

## P1. TANK

Tanks utilised:  
polyethylene tanks of 300, 400 and 600 litre capacity.

Each tank is made up of:

- tank main filler spout of 355 mm diameter, with collapsible lid, breather and labyrinth seal, for the filling with spraying products. Plastic cup-like filter: 302 mm external diameter, height 254 mm with powder mixing device;
- supplementary tank filler with 250 mm diameter screw-type lid, for filling with clear water and plastic cup-like filter: external diameter 204 mm, height 240 mm;
- incorporated polyethylene 17 litre capacity hand wash tank, with external service tap. Opening through a 255 mm diameter screw lid;
- hydraulic mixture shaker connected to the return piping T2;
- pneumatic mixture shaker, connected to the piston tap found above the tank and connected through piping to the air intake located on the fan casing.

A = OPEN  
C = CLOSED

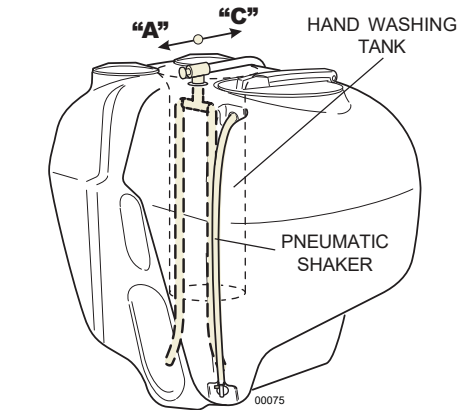
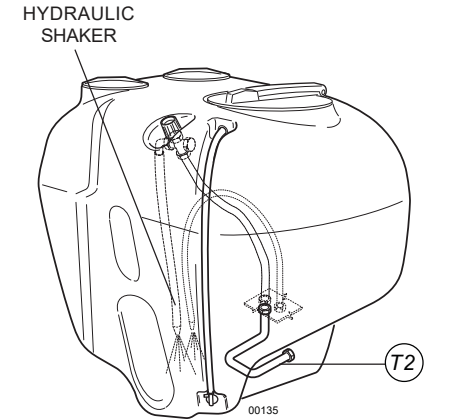

## P2 - 3-WAY LEVER TAP A WITH DISCHARGE FITTING

Fixed to tank P1 and connected to the suction piping T1.



With the machine in operation the tap's lever must face towards the suction piping T1 (position "a").  
By positioning the lever towards the drain plug (position "c"), total draining of the tank is obtained.  
In order to carry out the complete discharge of any liquid remaining in the pump and pipes, set the tap to position "b".

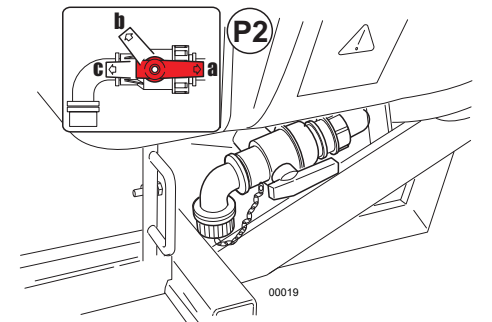



Remove the filler cap before shifting the drain cock lever. When the draining has taken place, return the lever to the working position (position "a") and screw the cap back on. These operations must be carried out with the machine stopped.

### T1 - SUCTION PIPING

It connects the tap P2 of the tank to tap P3 on the centrifugal pump.

### P3 - 2-WAY LEVER TAP

It is connected to the piping T1 and is secured to the suction fitting of pump P4.

**a = OPEN** when the control lever is parallel to the tap's body

**c = CLOSED** when the lever is perpendicular to the tap.

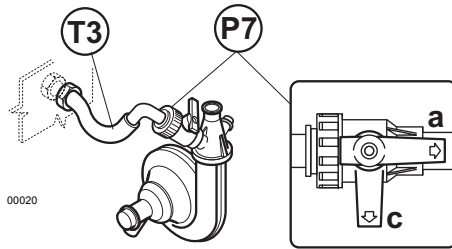

**IT MUST NORMALLY REMAIN IN THE OPEN POSITION.**

The tap must only be closed in order that the filling of the tank be carried out through the filler piping (see paragraph 8.3) AND ON COMPLETION OF THE OPERATION, IT MUST BE RE-OPENED (back to position "a").

### P4 - CENTRIFUGAL PUMP

It is mounted on the right-hand side of the machine and is connected to the three-way tap P5 and to the two two-way taps P7 and P3.

### P5 - 3-WAY LEVER TAP

It is mounted on the centrifugal pump (P4) and is connected to the body of the filter (P8).

When the tap's lever is set in position:

#### a. Pointing vertically downwards

The mixture is driven both to filter P8 and to the tank through piping T2. In this position, by opening distributor P10 (or E10) the mixture is driven to the head and the excess flow will return to the tank through the relative piping T2

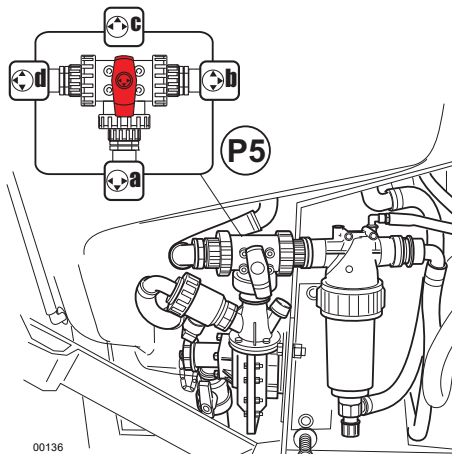

**TREATMENTS MUST BE CARRIED OUT ONLY WITH THE TAP IN THIS POSITION.**

4. Connect the filler piping to the pump.
5. Re-open P3-P7 (levers on "a").
6. Immerse the filter with the bottom-drawing valve in the water to be loaded.



**The filter must always be below the level of the water to be loaded. The piping must never be above the pump's suction point and must never be excessively bent in the vertical direction.**

7. Through the secondary filler BS, pour approximately 15~20 litres of water into the tank: the quantity must be sufficient to FILL the piping and ACTIVATE the pump to start the recycle.
8. Activate the power take off (PTO) and take it to a rotation speed of at least 500 revs / min.
9. When the pump has started the circulation of the water poured, close tap P3 (lever on "c") to start up the filling.

- 10a. WITH MEDICINAL MIXTURES OR LIQUID PRODUCTS (WITHOUT MIXER DEVICE)
  - 10a1. Pour the mixture of medicinal envisaged through the main filler (BP), together with the water used to wash the canister of product and the tools used in the preparation
  - 10a2. Close the main filler (BP) of the tank
  - 10a3. Having completed the filling with water, disengage the power take off (PdP)
  - 10a4. Close the tap (P5) setting the lever in position "c"
  - 10a5. Close the tap (P7) setting the lever in position "c"
  - 10a6. Disconnect the filler piping and replace the stopper on the pump
  - 10a7. Open the tap (P3) of the pump setting the lever in position "a"
  - 10a8. Open the tap (P5) setting the lever in position "a"
- 10b. WITH POWDER PRODUCTS: UTILISING THE MIXTURE DEVICE
  - 10b1. Pour the dose of medicinal in powder form foreseen for each loading into the main filler (BP) of the tank.
  - 10b2. Close the main filler (BP) of the tank
  - 10b3. Open the knob tap of filter (P8)
  - 10b4. Shift the lever of tap (P5) to the "b" position
  - 10b5. Wait for the filling to be completed
  - 10b6. Close the knob tap of the filter (P8)
  - 10b7. Disengage the power take off (PdP)
  - 10b8. Close taps P5 and P7 (levers on "c")
  - 10b9. Disconnect the filler piping and replace the stopper on the pump
  - 10b10. Open taps P3 and P5 (levers on "a")

11. Activate the power take off (PTO) and drive to the area to be treated, keeping a rotation speed of the power take off (PTO) of least 500 revs/min. for the whole distance.

#### IN THE AREA OF THE TREATMENT

12. Disengage the power take off (PTO) and rest the machine on the ground.



13. STOP THE TRACTOR AND REMOVE THE KEY FROM THE CONTROL PANEL.

14. Make sure that the fan is stopped. Hook the fan to the servo amplifier as indicated at point 8.1.b.
15. Start the tractor, always observing the safety norms.



- 5a5. Engage the drive outlet (PTO) and take it to a speed of at least 500 revs/min
- 5a6. Complete the filling with water and close the lid of the secondary filler (BS)
- 5a7. Close the filter's knob tap (P8)
- 5a8. Open the three-way tap (P5), setting its lever to position "a"

**5b. FILLING WITH MEDICINAL MIXTURES OR LIQUID PRODUCTS**

- 5b1. Pour the medicinal mixture envisaged for every loading (together with the water possibly used for the washing of product canisters and of the tools used in the preparation) into the main filler(BP).
- 5b2. Close the main filler (BP) of the tank
- 5b3. Engage the drive outlet (PTO) and take it to a speed of at least 500 revs/min
- 5b4. Complete the filling with water and close the lid of the secondary filler (BS)
- 6. Drive to the area to be treated, keeping a rotation speed of the drive outlet (PdP) of at least 500 revs/min. for the whole distance.

**FILLING DIRECTLY IN THE TREATMENT AREA:**

- 7. Disengage the drive outlet (PTO) and rest the spray atomiser on the ground.



**Stop the tractor and remove the key from the control panel.**

- 8. Ensure that the fan is stopped. Engage the fan to the servo amplifier as indicated at point 8.1, then re-close the mobile protection cover.



**Tighten the protection-securing screw properly.**

- 9. Start the tractor.
- 10. Hoist the machine. Engage the drive outlet (PTO) and, keeping the rotation speed around 500 revs/min, carry out a further shaking cycle.

CARRY OUT THE TREATMENT.

**8.3 - FILLING WITH THE SPECIFIC PIPING**



**Before utilisation, check the operation and proper sealing of the bottom-drawing valve by pouring water in the piping.**



**THE PUMP MUST NEVER RUN DRY.**

**EXECUTION:**

- 1. Disengage the fan, see point 8.1.a.
- 2. Close the 2-way distributor:
  - a. if manual (P10), set the levers in the horizontal position;
  - b. if electrical, position the latch switches (E10) on "OFF"
- 3. **Check that:**
  - P2 is open (lever on "a");
  - P5: is open (lever on "a");
  - P6: is open (work position); NOTE: at first filling of the spray atomiser CHECK that the pressure regulator is in the OPEN position;
  - P7 and P3: are closed (lever on "c");
  - P8: knob tap of the filter is closed.

Furthermore, by opening the handle tap of filter P8, with manual distributor P10 or electrical distributor E10 closed, it is possible to carry out the product mixing. A different momentary positioning of the lever is required at times, but only for certain operations that will be specified from time to time.

**b. Pointing horizontally to the right**



**Only the mixing of powder products is to be carried out in this position**

The whole flow from the pump is driven to filter P8. By opening the tap of filter P8 and by closing distributor P10 (or E10), the whole flow is driven to the mixer of the main filler BP.



**The return flow to the tank is closed through P6 and T2. The hydraulic shaking is stopped together with the flow towards the distribution device (head): this means that no flow is therefore present and it is not possible to carry out treatments.**

**c. Vertically upwards**

The flows towards both filter P8 and towards piping T2 are interrupted.



**This is to be positioned at the end of the tank's filling operation, before disconnecting the filling up piping. NEVER OPERATE THE SPRAY ATOMISER WITH TAP P5 IN THIS POSITION.**

**d. Pointing horizontally to the left**

The flow to piping T2 is open. The capacity flow towards filter P8 and to the feeding circuit is closed. This allows the cleaning of filter P8 even with a full tank; make sure that the handle tap of filter P8 is closed.

**P6. PRESSURE REGULATOR**

It is mounted on the tank and is connected to tap P5 through piping T2. It regulates the operating pressure by controlling the return flow to the tank.

- **By closing it: it REDUCES the return flow to the tank** and therefore, the shaking of the mixture, and it increases the operating pressure and capacity flow to the head (rotate the handle clockwise).
- **By opening it: it INCREASES the return flow to the tank** and therefore, the shaking of the mixture, while reducing the operating pressure and capacity flow to the head (rotate the handle anti-clockwise).



**When treatments are carried out with heavy powder products which have a tendency to form a deposit at the bottom of the tank, one must operate with a working pressure of 1 -1,5 atm, so as to allow for a better hydraulic shaking of the mixture.**

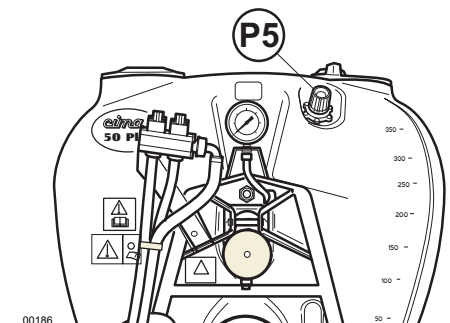

## T2. RETURN TO TANK PIPING

It connects tap P6 to tank P1, at the point on which the hydraulic shaker is mounted.

## P7. 2-WAY LEVER FILLING TAP

It is mounted on pump P4 and connected to tank P1 through the filler piping T3.

**a = OPEN** when the control lever is parallel at the tap's body

**c = CLOSED** when the lever is perpendicular to the tap.



It must normally remain in the closed position.

It is only opened to carry out the loading of the tank through the filler piping (see point 8.3).

When the operation is complete, it must be returned to the closed position.

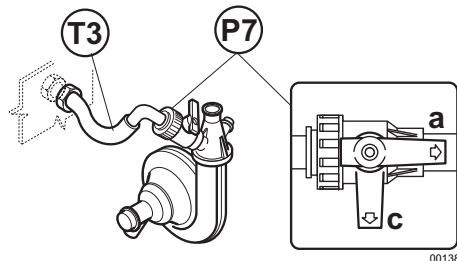

## T3. PIPING FOR THE LOADING

It connects tap P7 to tank P1 for the filling.

## P8. SELF-CLEANING IN-LINE DELIVERY FILTER

It is mounted on tap P5 and connected to the distributor (P10/E10) through the feed piping (T6).

A ring nut locks the lid to the filter body. The self-cleaning and mixing tap is set below the lid and is fitted with a control knob:

- OPEN (anticlockwise rotation) the tap to carry out the draining or the mixing of powder products;
- CLOSE (clockwise rotation) the tap in order that the operations are not carried out.

Filter (filtering capacity of 250 lt/min.), with a 50-mesh cartridge.

A soiled cartridge determines a lowering of the operating pressure.

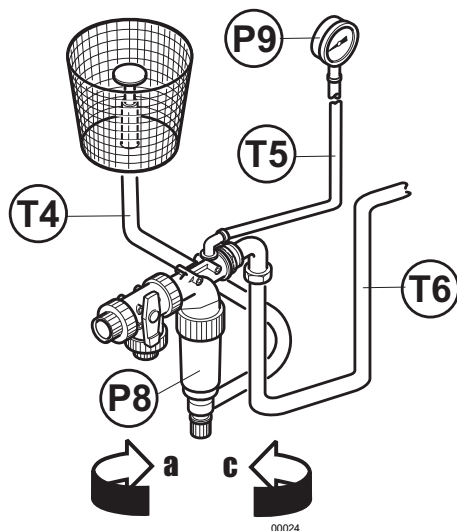

This malfunction is signalled by the relevant gauge.

This machine device only filters the feed flow to the heads, considerably reducing the chances of cartridge clogging.



## 8.1.b Latching of the fan to perform the treatment

EXECUTION:

1. Disengage the power take off (PTO) and rest the machine on the ground.
2.   Stop the tractor, remove the key from the control panel and check that the fan is stopped.
3. Undo the mobile protection cap's fixing screw and rotate it so as to access the disengagement tunnel.
4. Fully press the spring push button, push the front body forward, if necessary, turning it to the right or left, until the frontal teeth of the joint engage the corresponding teeth of the pulley; at the same time, the spring push button must return to the outward position. This way, the body is again integrated with the pulley, thus transmitting the movement to the fan.
5. Reposition the mobile protection cover and suitably tighten the securing screw.
6. Start the tractor and lift the spray atomiser to position the universal joint shaft.

## 8.2 - FILLING OPERATION THROUGH POURING FROM THE TOP



For this type of filling, utilise the supplementary filler (BS) located in the upper right-hand side of the tank, towards the front of the spray atomiser (opposite the filler of the hand washing tank).

**THE INLET OF THE FILLER PIPING MUST NEVER COME INTO CONTACT WITH THE ANTI-PARASITIC MIXTURE: IT MUST ALWAYS BE KEPT AT A SAFE HEIGHT ABOVE THE TANK FILLER AND MUST BE EQUIPPED WITH A NON-RETURN VALVE.**



**THE PUMP MUST NEVER RUN DRY**

EXECUTION:

1. Disengage the fan: see point 8.1.a.
  2. Close the taps of the 2-way distributor:
    - a. if manual (P10), set the levers in the horizontal position;
    - b. if electrical, position the latch switches (E10) on "OFF"
  3. Check that taps
    - P2 and P3: are open (lever in the "a" position);
    - P5: is in the working position (lever on "a");
    - P6: is open (working position). NOTE: upon the first filling of the spray atomiser CHECK that the pressure regulator is in the OPEN position;
    - P7: is closed (lever in the "c" position);
    - P8: filter knob tap is closed.
  4. Pour water in the tank to about 1/3 capacity through the supplementary filler BS.
- 5a. **FILLING WITH POWDER PRODUCTS BY UTILISING THE MIXER**
- 5a1. Pour the dose of the medicinal in powder form into the cup-like filter through the main filler (BP)
  - 5a2. Close the tank's main filler (BP)
  - 5a3. Open the filter's knob tap (P8)
  - 5a4. Set the lever of tap (P5) to the "b" position

THE FILLING MUST BE CARRIED OUT WITH THE MACHINE ON A FLAT SURFACE. ON THE SITE, BEFORE THE OPERATION, THE DOSES OR THE MIXTURES TO BE POURED INTO THE TANK MUST BE PREDISPOSED.





IT IS NECESSARY TO ALWAYS MAKE USE OF PERSONAL PROTECTION.

## 8.1 - FOREWORD - USE OF THE FAN DISENGAGEMENT

### 8.1.a Disengagement of the fan

EXECUTION:

1. Take the spray atomiser to the area in which it is to be filled and rest it on the ground.
2.   Stop the tractor, remove the key from the control panel and check that the fan has stopped.
3. Undo the mobile protection cap's fixing screw and rotate it so as to access the disengagement tunnel.

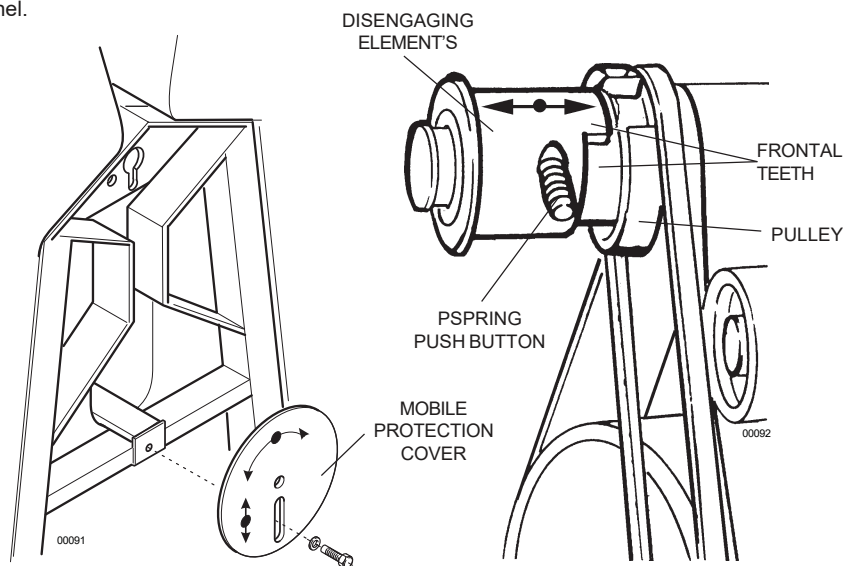

4. Fully press the spring push button and pull the front element until it springs out. The body disengaged from the retaining joint must turn freely: the pump will operate and the fan will thus be excluded.
5. Reposition the mobile protection cover and fasten the locking screw properly.
6. Start the tractor, lift the spray atomiser to position the universal joint shaft and carry out the filling operation..

## T4. PIPING FOR THE MIXING

It connects the self-cleaning tap of the filter (P8) with the cup-like filter in the tank.

## T5. GAUGE CONNECTION PIPING

It connects the filter (P8) to the gauge (P9).

## P9. GAUGE

Glycerine-dipped, with dial from 0 to 6 Kg/cm<sup>2</sup> (atmosphere) – adjustments scale of 1/10 of atmosphere, 100 mm diameter.



Adjust the operation pressure with distributors P10/E11 open.

## T6. PIPING FOR THE FEEDING

It connects the filter to the manual distributor (P10) or electric distributor (E11).

## P10. MANUAL DISTRIBUTOR WITH 2 LEVER-OPERATED TAPS

It is connected to the feeding pipes (T6) distribution piping (T7). It remote-controls the closing and opening of the pulverising. The anchoring bracket, supplied with the machine, must be secured to the tractor within the driver's reach. When the machine is not hitched to the tractor, it must be placed in the position envisaged on the forward part of the spray atomiser's frame. Each tap permits the dusting from a single side of the head: to the right and to the left respectively. They are **open** when the levers are set in the **vertical** position. They are **closed** when the levers are **horizontal**.

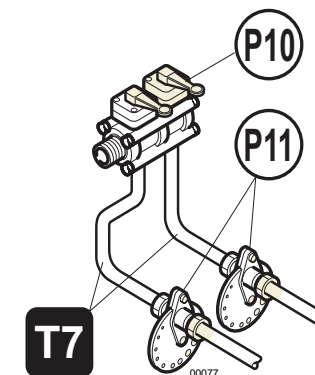

## E10. ELECTRICAL CONTROL UNIT

It is electrically connected to the distributor with 2 motorised solenoid valves (E11) and to the mains socket of the tractor. The unit is supplied with a complete electrical plug should the one present on the tractor be unsuitable for connection.

The 2 lever switches controlling solenoid valves E11, must be set to "ON" for opening and to "OFF" for closing.

The 2 lever switches controlling solenoid valves E11, must be set to "ON" for opening and to "OFF" for closing.

The unit is equipped with a bayonet support to be inserted in the bracket provided. This must be mounted on the tractor within the driver's reach. When the machine is not hitched to the tractor, it must be placed in the position envisaged on the forward part of the machine's frame.

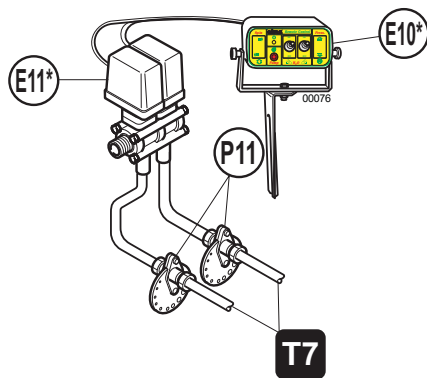

## E11. ELECTRICAL DISTRIBUTOR WITH 2 SOLENOID VALVES

It is connected to the feed piping (T6), the distribution piping (T7) and the electrical unit (E10) mounted on the tractor. The solenoid valves open and close following the command of the electrical control unit switches.

## T7. DISTRIBUTION PIPING

It connects the distributor P10/E10 to the rotating disc adjustment element (P11) assembled on the distribution devices.

## P11. ROTATING-DISC REGULATOR

It selects the flow rates necessary to the treatment and is mounted on the distribution devices.

It is made up of 2 flanges, held in position by two butterfly nuts, locking a disc with calibrated holes numbered from 1 to 15. A groove on the edge of the disc allows the exact positioning of the hole to be utilised.

Its number must appear in the flange's semi-circular seat. The rotation of the disc is obtained by loosening the butterfly nuts by a few turns. After the operation is done, screw back carefully.

 Any faulty sealing condition of the hydraulic circuit causes an intermittent issuing of the pulverised material. It is necessary to carefully check the efficiency of the sealers and clamps, the tightening of the ring nuts and fittings and the good working condition of the piping.

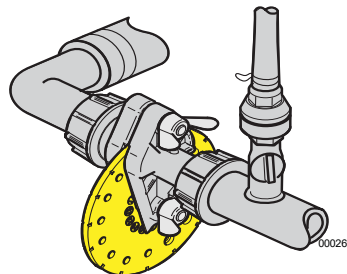

3. Introduce the wheels' axle shafts in the machine's axle.
4. Adapt the wheels' track to that of the tractor.
5. Lock the axle shafts by means of the axle screws.
6. Start the tractor and keep the spray atomiser lifted during the transfers, lowering it to carry out the treatment.

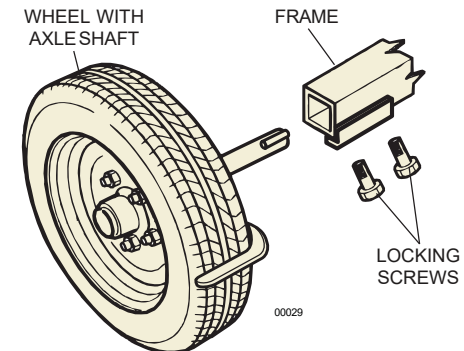

**THE SPRAY ATOMISER MUST BE LIFTED AT EVERY DIRECTION CHANGE MAKING SURE THAT THE WHEELS ARE NOT RESTING ON THE GROUND.**

	Plus					
	42	45	50	55	55S	55E
Wheel dimension	135/80 - 13			175-13		
Wheel pressure (atm)	3,3			2,5		
Wheel weight, with axles (Kg)	37			41		

UMAPT07GB



**The utilisation of NON ORIGINAL pairs of wheels not equipped with mud scrapers will nullify the machine's warranty.**



**The operating pressure of the tyres is indicated on the decal placed on the rim of each wheel.**

## 7.3 - GIREVOLE CON COMANDO A MANOVELLA



For its application, a 45° elbow is necessary.

It is an accessory utilised to modify the direction of the pulverising. It can be deployed only with some types of distribution devices.



**All indications and instructions are provided in the use and maintenance booklet of the distribution devices with which it can be used.**

## 7.4 - ELECTRICALLY CONTROLLED SWINGING DEVICE

It is an accessory utilised to modify the direction of the pulverising. It can be deployed only with some types of distribution devices.



**All indications and instructions are provided in the use and maintenance booklet of the distribution devices with which it can be used.**

### 7.1 - FILLER PIPING

The piping is provided with a coupling elbow fitting and with a bottom-drawing valve. This is used for the filling of the tank. It must be screwed into place on pump "P4" instead of the chain-held stopper.



The assembling must ALWAYS be carried out with taps P3 and P7 closed (all levers in position "c").



Before making use of it, it is necessary to check the operation and the proper sealing of the bottom-drawing valve, by pouring water into the pipe.

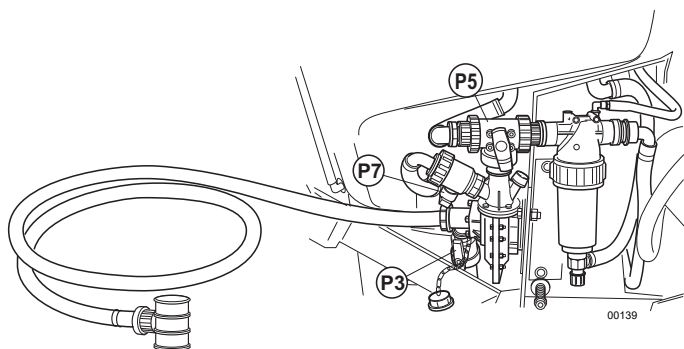

### 7.2 - PAIR OF WHEELS

The wheels thread can be adapted to that of the tractor.



**MOUNT THE WHEELS AFTER HAVING HITCHED THE MACHINE TO THE HOIST. DISMANTLE THE WHEELS BEFORE UNHITCHING THE MACHINE FROM THE HOIST.**

#### EXECUTION:

1. Hitch the machine to the tractor and lift it to a height at which the wheels can be mounted.



2. Stop the tractor, remove the key from the control panel and ensure that no one operates the hoist's hydraulic controls. **AVOID OPERATING AND STANDING BENEATH THE MACHINE OR WITHIN THE AREA THAT MIGHT BE INVOLVED IN ITS SUDDEN LOWERING.**

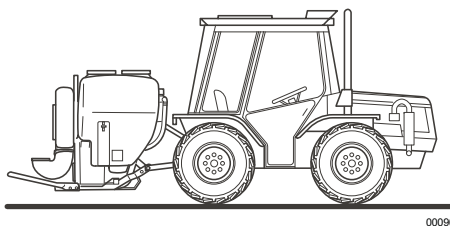

## 4.4 - TECHNICAL DATA

### 4.4.1- Spray atomiser dimensions and weights

(With protection ring - without distribution device - without accessories)

Plus		Tank capacity (litres)		
		300	400	600
42	Total width (mm)	960	1120	-
	Total height (mm)	1160	1180	-
	Length (mm)	1380	1380	-
	Weight, empty (kg)	195	200	-
	Weight, full load (kg)	513	618	-
45	Total width (mm)	960	1120	-
	Total height (mm)	1160	1180	-
	Length (mm)	1380	1380	-
	Weight, empty (kg)	202	207	-
	Weight, full load (kg)	520	625	-
50	Total width (mm)	960	1120	1450
	Total height (mm)	1160	1180	1230
	Length (mm)	1450	1450	1450
	Weight, empty (kg)	225	230	244
	Weight, full load (kg)	543	648	862
55 55S 55E	Total width (mm)	-	1120	1450
	Total height (mm)	-	1180	1230
	Length (mm)	-	1480	1480
	Weight, empty (kg)	-	236	250
	Weight, full load (kg)	-	654	868

UMAPT026B

### 4.4.2 - Technical specifications for fans and pumps

#### Centrifugal Fans

Plus	Type of spray atomiser carried					
	42	45	50	55	55S	55E
Fan diameter (mm)	450	450	500	550	550	550
Fan speed (revs/min.)	4000	4500	4000	3500	3700	3900
Air flow rate (m³/h)	4000	5400	7550	12500	14000	15500
Air speed (m/s)	228	188	175	150	170	180
Power absorbed (kW)	13	17	24	26	34	41

UMAPT026B

Plus	Type of spray atomiser carried			
	42	45	50	55-S-E
Steel fan	yes	yes	yes	yes
P.E. Casing	yes	yes	yes	yes
180° Elbow fitting	yes	yes	yes	-
Internal diameter casing outfeed (mm)	175	175	175	250
PTO shaft 1"3/8 SAE (DIN 9611/A)	yes	yes	yes	yes
Main pulley diameter (mm)	400	450	480	480
Fan control belt	610 J24	650 J32	690 J50	690 J50
Fan pulley diameter (mm)	54	54	64,5	75/70/66
Pump control pulley diameter (mm)	78	78	88	101/88/101
Pump control belt	3V 500	3V 500	3V 530	3V 530
Pump pulley diameter	78	82,5	82,5	82,5/88/82,5

UMAPTO4GB

### Centrifugal pump CD32

Model C.I.M.A. CD32 – Pressed in nylon – Turning open – Stainless steel shaft - Silicon carbide, stainless steel and viton mechanical seal, – Emptying cork – Oiling device with spring cover - Suction sleeve with supplementary service filler, provided with chain-retained cork. Activated with trapezoid belt driven by the pulley mounted on the fan shaft.

- Speed ..... 4000 revs/min. Plus42
- Flow rate ..... 120 litres/min. Plus42
- Speed ..... 4250 revs/min. Plus 45-50-55S-E
- Flow rate ..... 140 litres/min. Plus 45-50-55S-E
- Maximum pressure ..... 4.5 Kg/cm 2
- Power absorbed ..... kW 2.5



The performance specified is obtained with the drive outlet (PdP) at 540 revs/min. For a good result of the treatments this condition **MUST ALWAYS BE OBSERVED** during the machine's operation. Utilisation is permitted with speed rates ranging between 500 and 620 revs/min.

### 6.2 - POSITIONING OF THE FAN CASING

The fan's air outlet must be positioned according to the distribution device to be mounted and the modality in which it is to be utilised. The operation is possible since the fan's casing can be rotated on its axis up to 360°.

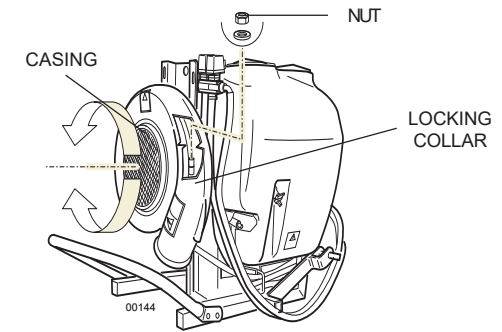

#### POSITIONING OF THE CASING:

1. Position the spray atomiser on the ground if it is mounted on the tractor.



**Switch off the tractor and remove the key from the control panel.**

2. By undoing the two locking nuts, loosen the collar which supports and locks the casing to the frame, located opposite the suction grill.
3. Rotate the casing and place the outlet in the position necessary for assembling (indications contained in the use and maintenance booklet of the distribution device).
4. After this has been done fasten the collar again.

### 6.3 - ELBOW FITTINGS OF THE DISTRIBUTION DEVICES

The elbow fittings support and connect the distribution devices to the fan casing. Several types are assembled on available standard machines (refer to Paragraph 4.4.2) while others, if not already available, must be supplied together with the distribution device.

COMPLETE SERIES PLUS	42 - 45 - 50	55 - 55S - 55E
STANDARD BASIC MODELS		
FAN PROVIDED	WITH 180° ELBOW	WITHOUT ELBOW



In the user and maintenance booklet of every distribution device the type of elbow necessary for the connection is specified together with the assembling instructions.



Every distribution device is supplied with its own **USE AND MAINTENANCE** booklet that is, or will have to be, attached to this publication and which will constitute one of its integral parts..

### 6.1 - TYPES AND IDENTIFICATION CODES

Distribution device - Head	PLUS			
	42	45	50	55-55S-55E
4+4 diffuser head with 8 taps	T.4+4.42.01	T.4+4.45.01	T.4+4.50.01	-
4+4 diffuser head with 8 Strasbourg-type taps	T.ST4.42P.01	T.ST4.45P.01	T.ST4.50P.01	-
5+5 diffuser head with 10 taps	T.5+5.42.01	T.5+5.45.01	T.5+5.50.01	-
7-diffuser canopy head	T.TND.42.01	T.TND.45.01	T.TND.50.01	-
4-diffuser multiple olive head	T.OL.000.42.01	T.OL.000.45.01	T.OL.000.50.01	T.OL.000.55.01
4-diffuser multiple olive head with 45°elbow	T.OL.045.42.01	T.OL.045.45.01	T.OL.045.50.01	T.OL.045.55.01
4-diffuser multiple olive head with 180°elbow	-	-	-	T.OL.180.55.01
Flexible cannon spout	T.GCF.42.01	T.GCF.45.01	T.GCF.50.01	-
Vertical cannon spout with 45°elbow	-	-	-	T.GCV.000.01
Tobacco cannon spout	-	-	-	T.GCV.045.01
Tobacco cannon spout with 45°elbow	T.GC.045.42.02	T.GC.045.45.02	-	-
Tobacco cannon spout (multiple diffuser)	-	-	T.GC.00.50P.02	T.GC.00.55P.01
Tobacco cannon spout (multiple diffuser) with 45°elbow	-	-	T.GC.045.50.02	T.GC.045.55.01
Tobacco cannon spout (multiple diffuser) with 180°elbow	-	-	-	T.GC.180.55.01
Crank control swing, dev., tobacco cannon spout command	T.GIR.M.175P	T.GIR.M.175P	T.GIR.M.175P	T.GIR.M.250P.01
Electrical swing dev. for tobacco cannon spout command	T.GIR.E.175P	T.GIR.E.175P	T.GIR.E.175P	T.GIR.E.250P.01
Manual pneumatic bar, 5 mt. with 8 x 2 diffuser spouts	BM.08.2.02	BM.08.2.02	-	-
Manual pneumatic bar, 7 mt. with 10 x 2 diffuser spouts	-	BM.10.2.02	BM.10.2.02	-
Hydraulic pneumatic bar, 12 mt. with 18 x 2 diffuser spouts and levelling pistons	-	-	B18.2.66.50.02	B18.2.66.55.02
2-fishtail sprayhead	-	T.2V35.45P.02	T.2V3L.50P.02	T.2V3L.55P.02
2-fishtail sprayhead	-	-	T.2V4.50P.01	T.2V8.55P.01
4-fishtail sprayhead	-	-	T.4V.50P.02	T.4V.55P.02
Head for potatoes with 180°elbow	-	-	-	T.PT.55P.02
Head for tomatoes with 180°elbow	-	-	-	T.PM.55P.02
Small cannon head, 2 lower hands and 2 upper cannons	-	TC.2M2M.45P.01	TC.2M2M.50P.01	TC.2M2M.55P.01
Small cannon head, France type, 2 lower hands and 2 upper cannons	-	TCF.2M2C.45P02	TCF.2M2C.50P02	TCF.2M2C.55P.02
Small cannon head, France type, 2 lower hand and 4 upper cannons	-	TCF.2M4C.45P02	TCF.2M4C.50P02	TCF.2M4C.55P02
Hydraulic movement head	-	TCI.2M4C.45P11	TCI.2M4C.50P11	TCI.2M4C.55P11
Coffee head	-	T.CA.45P.01	T.CA.50P.01	-

UMAP106

### 5.1 - HITCHING TO THE TRACTOR



Check that the tractor's "permissible carried weight" and the "rear overhang allowed" are compatible with the weight and dimensions of the fully loaded spray atomiser and complete with equipment mounted for the treatment (see Paragraphs "3.1" - "4.4.1" and the attached documentation).



The tractor's power take-off (PTO), under all utilisation conditions, must provide a power exceeding that absorbed by the spray atomiser.

The hitching between spray atomiser and tractor must be carried out on a flat surface, keeping away persons not involved in the operation, as well as children and animals.

Pairing suggested for tractors of at least	Plus					
	42	45	50	55	55S	55E
<b>CV</b>	25	45	65	70	80	90
<b>kW</b>	18	33	48	52	58	66

UMAP105

#### EXECUTION:

- Loosen the chains of the lifter arms.
- Start the tractor and take the lifter's arms to the level of the machine's pins..
- Stop the tractor and remove the key from the control panel.**
- Insert the toggle joints on the machine's pegs, locking them with the clip pins.
- Remove the 3<sup>rd</sup>-point rod of the tractor and mount it on the machine, securing it with the peg and the clip pin.
- Hook the rod to the tractor again, securing it with the peg and clip pin, screwing it finger-tight to set it into tension.
- Start the tractor and hoist the spray atomiser to take the 2 drive outlets (PdP) to the same height.
- Stop the tractor, remove the key from the control panel and make sure that no one approaches the hydraulic controls of the lifter. NEVER OPERATE OR STAND BENEATH THE MACHINE OR IN THE AREA THAT COULD BE INVOLVED IN ITS SUDDEN LOWERING.**
- By acting on the 3<sup>rd</sup>-point rod, vertically align the spray atomiser. **N.B.:** block the 3<sup>rd</sup>-point rod with the specific lock ring.
- Block the coupling by tightening the chains of the hoister arms.



When the operation is completed the 2 drive outlets (PTO) must be positioned on the same axis, both in vertical and horizontal direction.

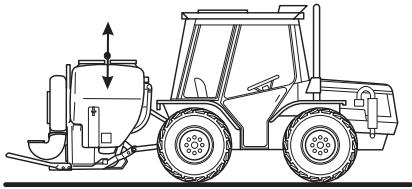

00027

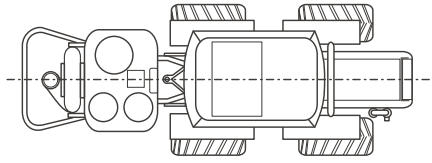

00080

## 5.2 - MOUNTING OF THE TRANSMISSION SHAFT



UTILISE TRANSMISSION SHAFTS WITH CE CERTIFICATION. OBSERVE THE REGULATIONS CONTAINED IN THE USE AND MAINTENANCE BOOKLET PROVIDED BY THE SHAFT MANUFACTURER.



The transmission shaft must work with the 2 COAXIAL drive outlets (PdP) or, should this not be possible, with the PARALLEL axles. In this case the angle of the joint MUST NOT EXCEED 15°.

### Definition of the length

Set the 2 drive outlets (PdP) perfectly on the same axis and measure the distance "D" between their grooves.

Length "L" of the transmission shaft (refer to the Picture) to be deployed, measured between the 2 stopping pawls and with joint closed, must be 25 mm lesser than distance "D".

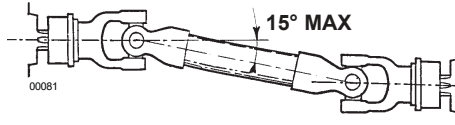

00081



The mounting, the disassembly or possible other interventions on the transmission shaft must be carried out with the engine switched off and with the starter key removed from the tractor's control panel.

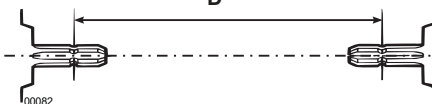
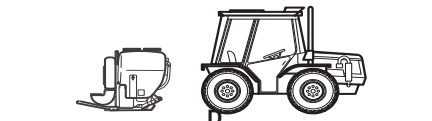

00082

$$L = D - 25$$

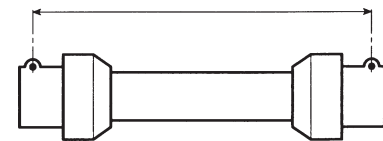

00083

## 5.3 - INSTALLATION OF THE REMOTE CONTROLS

### 5.3.1 - Manual distributor with 2 taps - P10

- 1 - Mount the securing bracket on the tractor within the driver's reach.
- 2 - Insert the distributor's bayonet support in the securing bracket.

- 3 - Connect the distribution piping T7 to the hydraulic circuit of the distribution device (head) mounted on the machine (follow the instructions of the specific "use and maintenance" booklet which is supplied with it).



Position the distribution piping T7 and feed piping T6 so as to avoid the risk of suffering damage or breakage during treatments. If necessary, utilise suitable securing clamps.

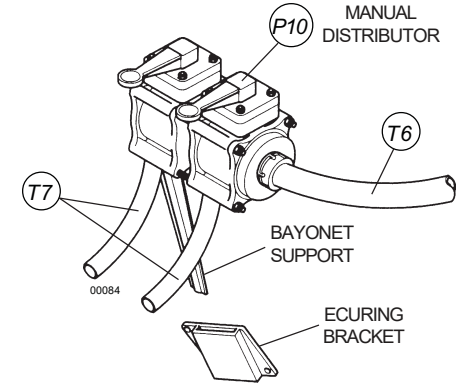

00084

### IN CASE OF BREAKAGE:

- 1 - Stop the tractor and remove the key from the control panel.
- 2 - Close the 2 taps of distributor "P10".
- 3 - Place the lever of the 3-way tap "P5" in position "d".

### 5.3.2 - Electrical control panel - E10

- 1 - Mount the securing clamp on the tractor within the driver's reach.
- 2 - Insert the bayonet support of the control panel in the securing clamp.
- 3 - Connect the mains cable "W1" inserting the plug into the mains socket of the tractor.



The mains cable "W1" is provided complete with mains socket to be mounted on tractors that might not be equipped with it, or to replace the existing one should it be incompatible with the plug.

4. Connect the distribution piping T7 to the hydraulic circuit of the distribution device (head) mounted on the machine (follow the instructions of the specific "use and maintenance" booklet which is supplied with it).



Position the electrical cables W1 and W2 in such a way as to avoid risking their being wrenched off during treatments. If necessary, utilise some securing clamps.

A sudden interruption of power will lock the 2 solenoid valves of the electrical distributor "E11". Should this fault take place when they are in the open position, it is necessary to:

- Stop the tractor and remove the key from the control panel.
- Position tap P5 on "d"..

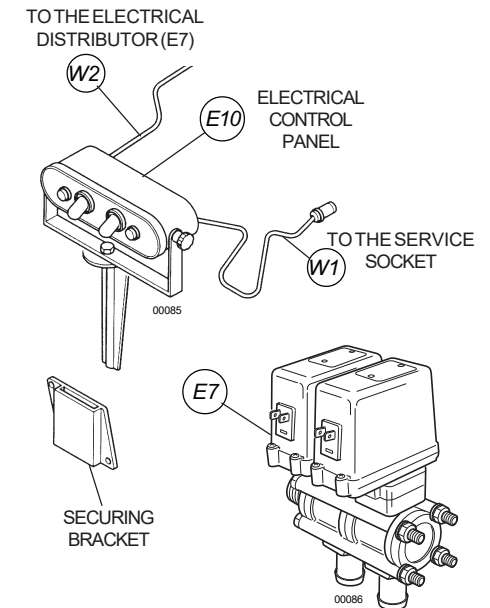

00085

00086