

**Low Volume
Mounted Sprayer**

OPERATION AND MAINTENANCE INSTRUCTIONS

cima® S.p.A.

27040 Montù Beccaria - Loc. Molino Quaroni - (PV) - ITALIA
Tel. +39.0385.246636 r.a. - Fax +39.0385.246637
<http://www.cimaitalia.com>

cima®

atomizzatori e impolveratori

Dear Customer, thank you very much!

*We want to congratulate with you, for having chosen a **cima**® sprayer.*

Your choice shows the wisdom of the well-informed Purchaser, aware of the fact, that the required features of quality, technique and reliability must be satisfied at the right price!

Our continuous engagement in R&D and in testing our machines allows us to realize products able to offer the best performances, a high reliability and a great easiness of use at the same time !

Our first goal, is to get our Customers happy for having met us!

The "Spare parts catalogue" of this sprayer/sprayhead is available in the "restricted area" on website www.cima.it.

In order to accede, use:

Username: **sprayer**

Password: **844719KE**

Where we are





| | | |
|---|---|--|
| DICHIARAZIONE DI CONFORMITÀ ai sensi della direttiva CEE 89/392 e successive modificazioni | | |
| DECLARATION OF CONFORMITY as per EEC directive: CEE 89/392 and subsequent modifications | DECLARATION DE CONFORMITÉ selon la directive 89/392/CEE et modifications ultérieures | |
| KONFORMITÄTSERKLÄRUNG im Sinne der Richtlinie 89/392/EWG und nachfolgenden Änderungen | DECLARACIÓN DE CONFORMIDAD con arreglo a la Directiva CEE 89/392 y sucesivas modificaciones | |
| CIMA S.p.A. - Loc. Molino Quaroni - 27040 MONTU' BECCARIA (PV) | | |
| dichiara sotto la propria responsabilità che la macchina: | | |
| hereby declares, under their personal responsibility, that the following machine: | | |
| déclarons sous notre responsabilité que la machine décrite ci-après: | | |
| erklärt hiermit auf eigene Verantwortung, daß das Gerät: | | |
| declara bajo la propia responsabilidad que la máquina: | | |
| na: | | |
| machine: | | |
| SERIE, TIPO - MODEL, TYPE - SERIE, TYPE - MODELL, TYP - SERIE, TIPO: | | |
| <input style="width: 100%; height: 20px;" type="text"/> | | |
| MATRICOLA - SERIAL NO. - MATRICULE - SERIENN. - MATRÍCULA N°: | | |
| <input style="width: 100%; height: 20px;" type="text"/> | | |
| è conforme ai requisiti essenziali di Sicurezza e di Tutela della Salute di cui alla Direttiva CEE 89/392 e sue successive modificazioni. | | |
| Per la verifica della Conformità di cui alle Direttive sopra menzionate, sono state consultate le seguenti: | | |
| Norme armonizzate EN: EN 294 EN 349. | | |
| conforms to the essential safety regulation as well as the Health requirements as per European economic community Directive: CEE 89/392 and subsequent modifications. For the verification of conformity as per above mentioned directives the following official En norms have been consulted: Harmonized EN norms: EN 294 EN 349. | est conforme aux exigences de Sécurité et de Sauvegarde de la Santé selon la directive 89/392/CEE et modification ultérieures. Pour vérifier la conformité aux directives susmentionnées, ont été prises en compte les normes suivantes: Normes harmonisées: EN 294 EN 349. | |
| mit den Grundvoraussetzungen für die Sicherheit und den Gesundheitsschutz laut der Richtlinie 89/392/EWG und nachfolgenden Änderungen übereinstimmt. Zur Überprüfung der Übereinstimmung mit den obengenannten Richtlinien wurden die folgenden Vorschriften konsultiert: EN-angeglichene Normen: EN 294 EN 349. | cumple con los requisitos esenciales de Seguridad y de Preservación de la Salud contenidos en la Directiva CEE 89/392 y sucesivas modificaciones. Para comprobar la Conformidad a la que se refieren las Directivas anteriormente citadas, se han consultado la siguientes: Normas Armonizadas EN: EN 294 EN 349. | |
| Responsabile della Sicurezza - The Security Official - Responsable Sécurité et Homologations - Der Sicherheitsverantwortliche - Responsable de la Seguridad | | |
| Data, Date, Date, Datum, Fecha, _____ | | |

UMAP072a

LOW VOLUME MOUNTED SPRAYER

P 42 - P 45 - P 50
P 55 - P 55S

Serial No.:

INSTRUCTIONS FOR USE AND MAINTENANCE



27040 MONTU' BECCARIA - PV - ITALIA
 Loc. Molino Quaroni - Tel. 0385/246636 r.a. - Fax 0385/246637

LIST OF VALID PAGES

This publication is composed of 64 pages divided in the following manner:

| PAGE NO. | REVISION | ISSUE DATE |
|--------------|----------|------------|
| from I to IV | 00 | March 1995 |
| from 1 to 60 | 02 | March 1999 |

REGISTRATIONS OF ADDITIONS AND CHANGES

| REVISION | DESCRIPTION |
|----------|---------------------|
| 00 | Edition, March 1995 |
| 01 | Edition, May 1996 |
| 02 | Edition, March 1999 |
| 03 | |
| 04 | |
| 05 | |
| 06 | |
| 07 | |
| 08 | |

18

NOISE LEVEL

18

L qA: Observed equivalent average sound level, expressed in dB (A).

| Sprayer model | Noise level L qA - dB(A) |
|---------------|-----------------------------|
| P42 | 89,0 +- 0,2 |
| P45 | 92,4 +- 0,2 |
| P50 | 99,4 +- 0,2 |
| P55 | 95.4 +- 0,2 |
| P55S | 95,4 +- 0,2 |
| P55E | 95,4 +- 0,2 |

UMAPT13I

19

GUARANTEE

19



THE OPERATOR IS NOT ALLOWED TO CARRY OUT MODIFICATION ON THE ATOMIZER STRUCTURES OR ON ITS OPERATION. THIS WOULD MEAN IMMEDIATE LOSS OF THE EXISTING RIGHTS OF GUARANTEE AND WOULD FREE C.I.M.A. S.P.A. FROM ANY CONSEQUENT RESPONSIBILITY.

The machines are guaranteed for **12 months** from the date of delivery. During this time, the parts that are not normally subject to wear and that are found defective, will be replaced free of charge, except for transport and workmanship costs.

The guarantee is no longer valid when:

- a. The machine is repaired without the permission of the manufacturer or of one of its service centers.
- b. Non-original spare parts are used.
- c. The machine is used for purposes different from its original intended use.
- d. The instructions contained in this manual and in its accompanying parts have not been complied with.

17.2 - ELECTRIC CONNECTIONS

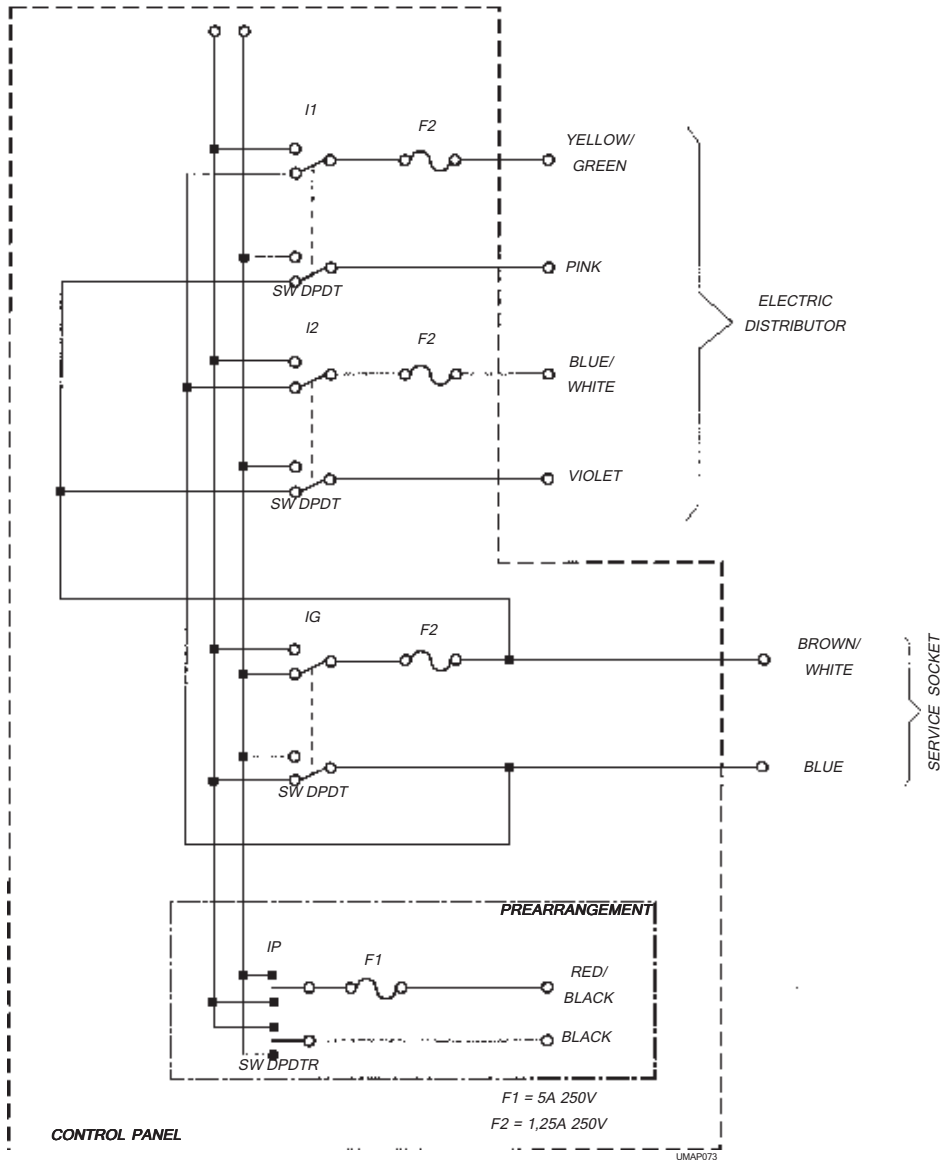

TABLE OF CONTENTS

| | | |
|----------|---|-----------|
| 1 | INTRODUCTION | 1 |
| 1.1 | PUBLICATION IDENTIFICATION | 1 |
| 1.2 | PUBLICATIONS ATTACHED | 1 |
| 1.3 | PURPOSE OF THE PUBLICATION | 1 |
| 1.4 | REFERENCES TO REGULATIONS | 1 |
| 1.5 | USE OF THE MANUAL | 1 |
| 1.6 | UPDATES | 2 |
| 2 | GLOSSARY | 3 |
| 2.1 | TERMINOLOGY | 3 |
| 2.2 | ABBREVIATIONS | 3 |
| 2.3 | SAFETY DECALS | 3 |
| 3 | GENERAL INFORMATION | 7 |
| 3.1 | IDENTIFICATION OF THE MACHINE | 7 |
| 3.2 | TECHNICAL ASSISTANCE | 7 |
| 3.3 | SAFETY WARNINGS | 7 |
| 3.4 | SAFETY DEVICES | 8 |
| 3.5 | HANDLING OF AGROCHEMICAL PRODUCTS | 9 |
| 3.5.1 | Storage | 9 |
| 3.5.2 | Specific equipment | 9 |
| 3.5.3 | Disposal of empty containers and agrochemical residue | 9 |
| 3.5.4 | Personal protection means | 10 |
| 4 | STRUCTURAL ANALYSIS OF THE MACHINE | 11 |
| 4.1 | FRAME | 11 |
| 4.2 | GEARBOX-FAN | 12 |
| 4.3 | HYDRAULIC CIRCUIT COMPONENTS | 13 |
| 4.4 | TECHNICAL DATA | 17 |
| 4.4.1 | Machines dimensions and weights | 17 |
| 4.4.2 | Fan-pump functional characteristics | 17 |
| 4.4.3 | Fan technical characteristics | 18 |
| 5 | COUPLING MODE | 19 |
| 5.1 | TRACTOR HOOK-UP | 19 |
| 5.2 | DRIVE JOINTS ASSEMBLY | 20 |
| 5.3 | INSTALLATION OF REMOTE CONTROLS | 21 |
| 5.3.1 | P7 - 2 cocks manual distributor | 21 |
| 5.3.2 | E8 - Electric control unit | 21 |
| 6 | DISTRIBUTION DEVICES | 23 |
| 6.1 | TYPES AND IDENTIFICATION CODES | 23 |
| 6.2 | ORIENTATION OF THE FAN-GUARD | 24 |
| 6.3 | ELBOW UNIONS FOR THE DISTRIBUTION DEVICES | 24 |
| 7 | INSTALLATION OF THE ACCESSORIES | 25 |
| 7.1 | FILLING PIPING | 25 |

| | | |
|-----------|--|-----------|
| 7.2 | COUPLE OF WHEELS | 25 |
| 7.3 | CRANK CONTROLLED ROTOR | 26 |
| 7.4 | ROTATING GROUP WITH ELECTRIC CONTROL | 26 |
| 8 | FILLING PROCEDURES | 27 |
| 8.1 | INTRODUCTION - USE OF THE FAN RELEASE | 27 |
| 8.2 | BY INLET | 28 |
| 8.3 | WITH FILLING PIPING | 29 |
| 9 | MIXTURE AGITATION | 31 |
| 10 | DISCHARGE OF THE HYDRAULIC CIRCUIT | 31 |
| 11 | SPRAYER ADJUSTMENT | 32 |
| 11.1 | BASIC INFORMATION: "LOW VOLUME" | 32 |
| 11.2 | DETERMINING THE ADJUSTMENT DATA | 35 |
| 12 | PROCEDURES FOR USE | 46 |
| 12.1 | OPERATIONS PRIOR TO TREATMENT | 46 |
| 12.2 | OPERATIONS IN PREPARATION FOR TREATMENT | 46 |
| 12.3 | TREATMENT | 47 |
| 12.4 | END OF TREATMENT - STORAGE | 48 |
| 12.4.1 | Daily | 48 |
| 12.4.2 | End of seasonal cycle | 48 |
| 13 | LIFTING AND TRANSPORT | 49 |
| 14 | MAINTENANCE OPERATIONS | 50 |
| 14.1 | LUBRICATION | 50 |
| 14.2 | CLEANING THE DELIVERY FILTER | 51 |
| 14.3 | CLEANING THE FAN (ONLY FOR P42E P45E P50E) | 51 |
| 14.4 | FAN BELT STRETCHER | 52 |
| 14.5 | PUMP BELT STRETCHER | 52 |
| 14.6 | TABLE OF MAINTENANCE OPERATIONS | 53 |
| 15 | TROUBLE SHOOTING | 54 |
| 16 | REPAIRS ALLOWED | 56 |
| 16.1 | ASSEMBLING THE PUMP CONTROL BELT | 56 |
| 16.2 | REPLACING THE FUSES OF THE ELECTRIC UNIT | 56 |
| 17 | INTEGRATIVE DIAGRAMS | 57 |
| 17.1 | HYDRO-PNEUMATIC DIAGRAM | 57 |
| 17.2 | ELECTRIC CONNECTIONS | 58 |
| 18 | NOISE LEVEL | 59 |
| 19 | GUARANTEE | 59 |
| 20 | ENCLOSED: STATEMENT OF CONFORMITY | 60 |

17

INTEGRATIVE DIAGRAMS

17

17.1 - HYDRO-PNEUMATIC DIAGRAM

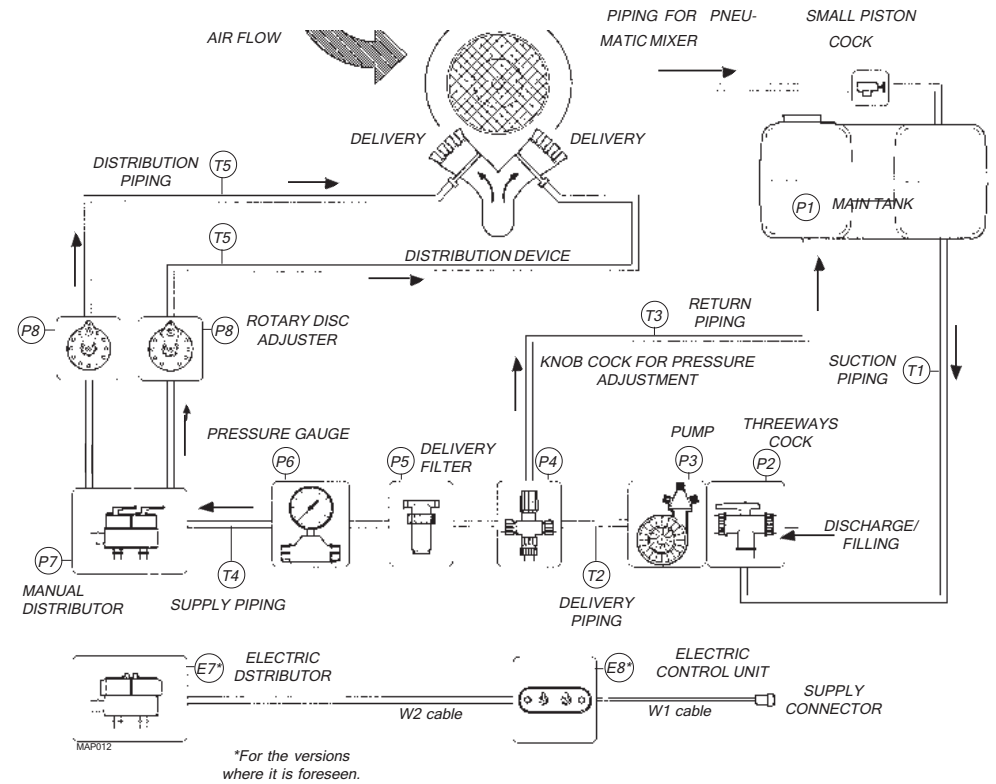

16 REPAIRS PERMISSIBLE 16



THE OPERATOR IS NOT ALLOWED TO CARRY OUT MODIFICATIONS ON THE ATOMIZER'S STRUCTURES OR IN ITS OPERATION. THIS WOULD MEAN THE IMMEDIATE LOSS OF ALL THE EXISTING RIGHTS OF GUARANTEE AND WOULD FREE C.I.M.A. S.p.A. OF ANY CONSEQUENT RESPONSIBILITY.

16.1 - ASSEMBLING THE PUMP CONTROL BELT



Stop the motor and take the ignition key out of the tractor control panel.

1. Remove the outer-guard protecting the PtO by unscrewing its 3 fastening screws.
2. Remove the mobile cover by unscrewing the nut fixing it to the frame and the 2 spring screws.
3. Unscrew the belt tensioner spring adjustment nut: the pump supporting plate is now free to rotate.
4. Introduce the belt into the pump pulley groove and then into the groove of the upper pulley, behind the release.
5. Reset the belt tensioner spring in in the prescribed tension condition.
6. Re-fit the mobile cover and the PtO counter-guard.

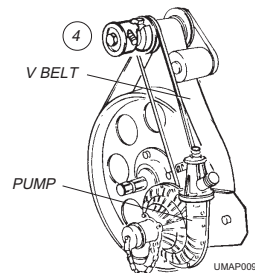
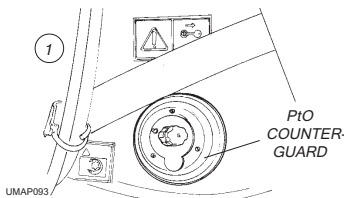
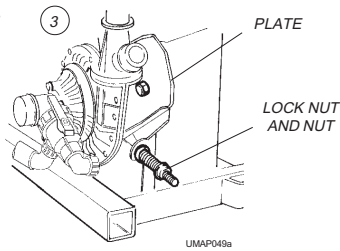
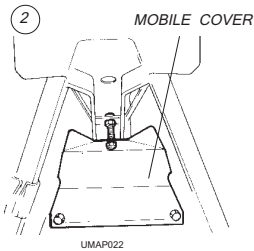

Accurately tighten the screws and the nut previously removed for assembly.

16.2. - REPLACING THE FUSES OF THE ELECTRIC UNIT



Stop the motor and take the ignition key out of the tractor's control panel.

1. Unscrew the fuse box cover;
2. Replace the fuse and screw the cover again.

* Fuse: 1,25 A with delay.

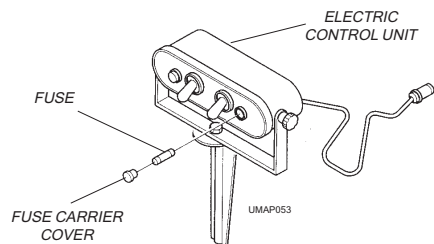

ALL OTHER TYPES OF REPAIRS MUST BE CARRIED OUT AT A CIMA S.P.A. AFTER-SALE SERVICE CENTER.

1 INTRODUCTION 1

1.1 - PUBLICATION IDENTIFICATION

The manual "INSTRUCTIONS FOR USE AND MAINTENANCE" is an official document issued by C.I.M.A. S.p.A. and is considered an additional part of the machine. The manual displays a publication number on the third cover page which allows for identification, tracing and reference.

All of the information contained herein has been accurately checked. C.I.M.A. S.p.A. reserves the right to modify this manual without prior notice and does not take responsibility for any errors and/or omissions.

1.2 - PUBLICATIONS ATTACHED

- Spare parts catalogue;
- Instructions for use and maintenance of the distribution devices;
- Distribution devices, Spare parts catalogue.

1.3 - PURPOSE OF THE PUBLICATION

All of the necessary indications for use and maintenance contained in this manual are intended for the utilization of the duster. The duration and functionality of the machine, the operator's safety and regard for the environment all depend on the careful observance of the regulations described herein.

Before using the duster, the operator should read and respect all of the instructions listed in this manual, which are updated through the publication date.

1.4 - REFERENCE TO REGULATIONS

This manual was created in conformity with the instructions contained in:

- Enclosure "I" of Instruction 89/392/C and subsequent modifications (letters "b", "c" of point 1.1.2 and point 1.7.4);
- UNI EN 292/2 - 1992, point 5.5.

1.5 - USE OF THE MANUAL

Read this manual from the beginning to the end without omitting any pages, paying special attention to the meaning of the warning or danger instructions in the text and indicated by the signs displayed on the machine or on its parts. All of the operations described herein should be carried out with the utmost care and only after having understood the negative consequences of executing them poorly.

The manual is divided into two parts.

* The first, whose pages are marked with Roman numerals, consists in:

- Title page
- List of valid pages
- Registration of additions and changes
- Table of contents

This allows for the identification of the publication and awareness of its level of updating and validity regarding the product. The table of contents allows the user to find the pages concerning the subject he/she is interested in quickly and efficiently.

* The second part, whose pages are marked with cardinal numbers, has been developed to give the user the necessary information for working while respecting the safety standards during all of the stages of preparation, use, handling and maintenance of the duster.

In the course of the text, we have used some symbols to highlight and visually distinguish the importance of the different kinds of information.

Graphic representation and meaning of the symbols:



Indicates important supplementary information.



The non observance of the instruction given herein may cause damage to the atomizer which could be irreparable.



Indicates possible situations of danger for persons.

The manual, its enclosures and its possible additions, should be kept with the utmost care and always be complete, integral and legible in all of its parts. In case of loss, the owner must immediately ask C.I.M.A. S.p.A. for a duplicate. If the decals originally placed on the machine should become lost, damaged or even partially incomprehensible, they must be replaced without delay.

Each type off head which can be used with the atomizer is delivered complete with a specific manual for use and maintenance. This constitutes an enclosure to this publication. All of the head manuals must always come with the machine manual.



- The manual should be kept for the entire life of the atomizer.
- All of the amendments received must be kept by inserting them in this publication.
- The manual should come with the atomizer when it is sold.

1.6 - UPDATES

The possible updates that C.I.M.A. S.p.A. may send to the owner of the atomizer will be accompanied by the necessary instructions for inserting them in this publication.

If the machine is sold, the owned must ask the buyer to communicate his/her address to C.I.M.A.S.p.A., in order for them to send the possible additions.

E. PROBLEM: Abnormal and constant noise with vibration of the fan group

1. CAUSE Breakage of the fan' shaft bearings.
REMEDY: Refer to C.I.M.A. after-sale service.

F. PROBLEM: Intermittent delivery of the whole distribution device

1. CAUSE Seal leak in that part of hydraulic circuit going from the tank's suction piping (T1) to the manual (P7) or electric (E7) distributor.
REMEDY: Carefully check all points where air suction may occur, included those where liquid leakage does not appear.
Check functionality of the pump and its belt. Check tightening of ring nuts, unions and clamps. Verify the efficiency of gaskets and the integrity of pipings. Reset the efficiency and replace the possible faulty parts.

G. PROBLEM: Intermittent delivery from one side only of the distribution device

1. CAUSE Seal leak of seal in that part of the hydraulic circuit going from the manual (P7) or electric (E7) distributor to the involved distribution point.
REMEDY: As per point F.1.

H. PROBLEM: Non-delivery of liquid: completely on side only of the distribution device

1. CAUSE The cocks of the manual distributor (P7) are dirty or clogged.
REMEDY: Clean them.
- 1b. CAUSE The cocks of the electric distributor (E7) are blocked by scaling in the closing position.
REMEDY: Clean them with clean water.
- 2b. CAUSE The fuses of the electric control unit are blown when the cocks of the electric distributor (E7) are closed.
REMEDY: Replace the fuses.
- 3b. CAUSE Incorrect connection of the W1 supply cable of the electric control unit to the cocks of E7 electric distributor E7 in closing position.
REMEDY: Connect it correctly.
- 4b. CAUSE Faulty electric connections.
REMEDY: Refer to C.I.M.A. after-sale service.
5. CAUSE Faulty pump (only in case of complete non-delivery).
REMEDY: As per point "B".
6. CAUSE Broken pump belt.
REMEDY: Replace the belt.



THE CAUSES AND REMEDIES FOR PROBLEMS IN DELIVERY OF LIQUID FROM ONE OR MORE SPRAYERS ARE DETAILED IN THE USE AND MAINTENANCE MANUAL OF EACH DISTRIBUTION DEVICE.

15 TROUBLE SHOOTING 15

A. PROBLEM:When using the self-filler the pump does not aspirate

1. CAUSE The quantity of water poured into the tank is not enough to prime the pump.
REMEDY: Add water to the tank until the pump begins to recycle.
2. CAUSE The foot valve takes air in.
REMEDY: Fully immerse the foot valve.
3. CAUSE Lack of seal of the hydraulic circuit.
REMEDY: Check tightening of ring nuts, unions and clamps. Verify the efficiency of gaskets and the integrity of pipings. restore working order and replace all possible faulty parts.
4. CAUSE Slippage of the pump belt.
REMEDY: Check the tension of the belt stretcher spring.
5. CAUSE Breakage of the pump belt.
REMEDY: Replace the belt.

B. PROBLEM:Leakages and drips from the pump

1. CAUSE Leak of seal in unions and clamps connecting the pipings to the pump.
REMEDY: Check tightening of ring nuts and clamps. Verify the efficiency of gasket. Replace the possible faulty parts.
2. CAUSE Leak of seal (O-ring) of the outside pump coupling flanges.
REMEDY: Refer to C.I.M.A. after-sale service.
3. CAUSE Breakage of mechanic seal.
REMEDY: Refer to C.I.M.A. after-sale service.

C. PROBLEM:Hydraulic circuit pressure drop signalled by the pressure gauge

1. CAUSE Delivery or suction filter are dirty.
REMEDY: Clean the cartridge.
2. CAUSE Lack of seal in the hydraulic circuit.
REMEDY: Check functionality of the pump and its belt. Check tightening of ring nuts, unions and clamps. Verify the efficiency of gaskets and the integrity of pipings. Restore working order and replace the possible faulty parts.
3. CAUSE Faulty centrifugal pump. See point "B".
REMEDY: As in point "B".
4. CAUSE Faulty pressure gauge.
REMEDY: Refer to C.I.M.A. after-sale service.

D. PROBLEM:Vibration of the fan group

1. CAUSE The fan is dirty.
RIMEDIO: Clean it. For the range P55DE and S call the C.I.M.A. after-sale service.
2. CAUSE The 2 PTOs are not aligned or are not parallel.
REMEDY: Position the 2 PTOs in the correct way.

2 GLOSSARY 2

2.1 - TERMINOLOGY

The terms FRONT, REAR, RIGHT and LEFT used in this publication are referred to the atomizer as seen by an operator standing behind the operative unit and looking at the same; the rear part of the machine is the nearest to the operator, where the head is mounted; the front part is where the atomizer is hitched to the tractor. The "distributing device" can also be called "distribution head".

2.2 - ABBREVIATIONS

| | |
|---------------------|---------------------------------|
| g | grams |
| g/1' | revolutions per minute |
| h | hour |
| ha | hectares |
| ha/h | hectares per hour |
| l | litres |
| l/h | litres per hour |
| kg | Kilograms |
| km | Kilometers |
| km/h | Kilometers per hour |
| Lm | Width in metres |
| m | metres |
| Mesh | No. of meshes per straight inch |
| Micron | 1/1000 of millimeter |
| PTO | power take-off |
| s | seconds |

2.3 - SAFETY DECALS

The machine is provided with decals concerning safety, use and maintenance.

Safety

- | | | |
|----------|----------------|---|
| 1 | - 95001 | - STOP THE MOTOR AND TAKE THE KEY OUT OF THE TRACTOR CONTROL PANEL BEFORE CARRYING OUT ANY MAINTENANCE OR REPAIR OPERATION. - Position: under the main tank, on the mobile protection. |
| 2 | - 95004 | - DANGER: CONTAMINATION DUE TO CONTACT WITH OR INHALATION OF POISONOUS PRODUCTS. - Position: on the main tank, near the loading opening. |
| 3 | - 95005 | - DANGER: ROTATING COMPONENTS. BEFORE REMOVING THE PROTECTIVE DEVICES, STOP THE TRACTOR, TAKE THE KEY OUT OF THE CONTROL PANEL AND MAKE SURE THAT ALL COMPONENTS HAVE STOPPED. - Position: on the fan's guard, near the outlet opening. |
| 4 | - 95008 | - THE MACHINE HAS NO ADDITIONAL HANDWASH TANK. - Compare sotto il serbatoio lavamani quando non è montato. |

- 5 - 95015 - **BEFORE USING THE RELEASE, STOP THE TRACTOR TAKE THE KEY OUT OF THE CONTROL PANEL AND MAKE SURE THAT THE FAN HAS STOPPED.**
- Position: On the frame, near the manometer.
- 6 - 95010 - **MAXIMUM WORKING SPEED OF THE POWER TAKE-OFF: 540 RPM.**
- Position: near the power take-off (PTO).
- 7 - 95007 - **DANGER: SPRAYS. REMAIN AT A SAFE DISTANCE.**
- Position: on the fan's guard.
- 8 - 95006 - **ATTENTION: CONSULT THE USE AND MAINTENANCE MANUAL BEFORE USE OR WORK ON THE MACHINE.**
- Position: up, right-hand side, on the machine front part.
- 9 - 95009 - **DANGER: USE PROTECTIVE GLOVES WHEN DISCHARGING THE TANK.**
- Position: on the frame, high left-hand side, near the pump.
- 10 - 95012 - **DANGER: FIT THE WHEELS ONLY AFTER HOOKING THE MACHINE TO THE HOIST AND REMOVE THEM AFTER RELEASING THE MACHINE FROM THE HOIST (ACCESSORY).**
- Position: on the frame, near the axle.
- 11 - 95059 - **HOOKING POINT FOR LIFTING THE MACHINE.**
- Position: on the frame, over the fan's guard.

Use and maintenance

- 12 - 95052 - **GREASE EVERY 20 HOURS: FAN SHAFT BEARINGS.**
- Position: on the frame, near the fan's guard, left-hand side.
- 13 - 95053 - **GREASE EVERY 50 HOURS: FAN BELT STRETCHER SUPPORT.**
- Position: on the frame, near the fan's guard, right-hand side.
- 14 - 95054 - **GREASE EVERY 200 HOURS: FREE WHEEL.**
- Position: on the front part, near the PTO protection guard.
- 15 - 95067 - **OIL EVERY 50 HOURS: PUMP BEARINGS.**
- Position: on the left-hand side, near the pump.
- 16 - 95057 - **HANDWASH TANK COCK.**
- Position: on the hand-wash tank.
- 17 - 95065 - **ATTENTION: NEVER LET THE ATOMIZER RUN WITHOUT LIQUID INSIDE THE TANK.**
- Position: on the main tank, front side.
- 18 - 95063 - **INSTRUCTIONS FOR USE AND MAINTENANCE OF THE ELECTROVALVES.**
- Position: on the tank, near the electric distributor.
- 19 - 95060 - **WHEEL OPERATING PRESSURE (ACCESSORY).**
- Position: on the wheel.
- 20 - 95074 - **OPERATION OF THE THREE-WAY VALVE.**
- Position: on the frame, low left-hand side, near the pump.



THE 5-FIGURE NUMBERS ARE THE CODES TO BE USED FOR ORDERING DECALS.

14.6 - TABLE OF MAINTENANCE OPERATIONS

| CHECK | AT THE BEGINNING OF SPRAYING SEASON | BEFORE EACH TREATMENT | AFTER EACH TREATMENT | END OF SPRAYING SEASON | RATE RECOMMENDED |
|--|-------------------------------------|-----------------------|----------------------|------------------------|------------------|
| Fan belt tensioner spring: CHECK LENGTH 9-12 cm. | YES | YES | ** | ** | ** |
| Pump belt tensioner spring: CHECK LENGTH 4-5 cm. | YES | YES | ** | ** | ** |
| Fan support and low support: GREASE. | YES | ** | ** | YES | 20 h |
| Fan belt tensioner support: GREASE. | YES | ** | ** | YES | 50 h |
| Pump bearing: OIL. | YES | ** | ** | YES | 50 h |
| Free wheel: GREASE. | YES | ** | ** | YES | ** |
| Couplings and pipings: CHECK THEIR INTEGRITY. | YES | YES | ** | ** | ** |
| Clamps and fittings: CHECK TIGHTENING. | YES | YES | ** | SI | ** |
| Delivery filter: CHECK CLEANLINESS. | ** | YES | YES | YES | ** |
| Hydraulic circuit and tank: WASH. | ** | ** | YES | YES | ** |
| Hydraulic circuit and tank: CLEAN AND COMPLETELY EMPTY. | ** | ** | ** | YES | ** |
| Calibration disk : CLEAN. | ** | YES | YES | YES | ** |
| Tyres pressure: CHECK. | ** | YES | ** | ** | ** |
| Sprayer: CHECK. | ** | ** | YES | YES | ** |
| Sprayer: STORE. | ** | ** | ** | YES | ** |

14.4 - FAN BELT TENSIONER

Check the length "L" of the spring (see picture): it must be in tension between 9 and 12 cm.

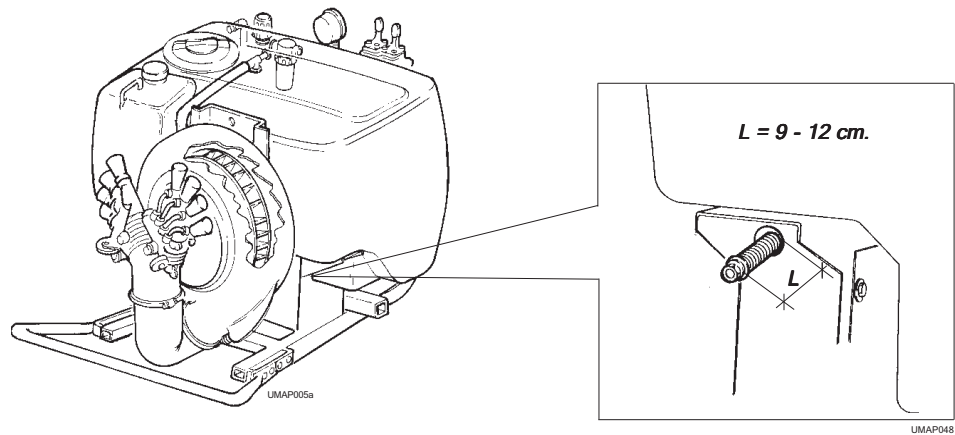

14.5 - PUMP BELT TENSIONER

Check the length "L" of the spring (see picture): it must be in tension between 4 and 5 cm.

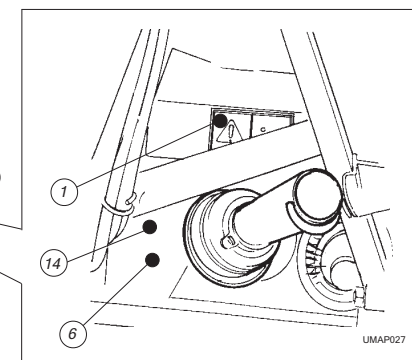
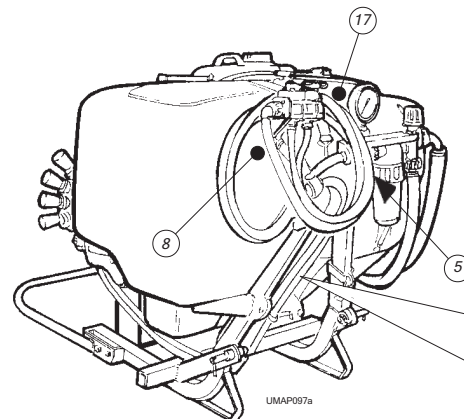
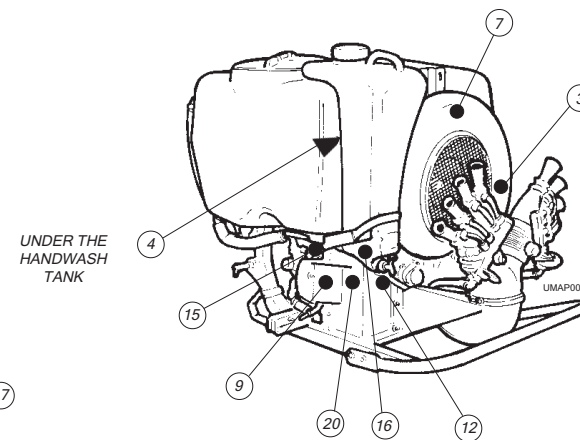
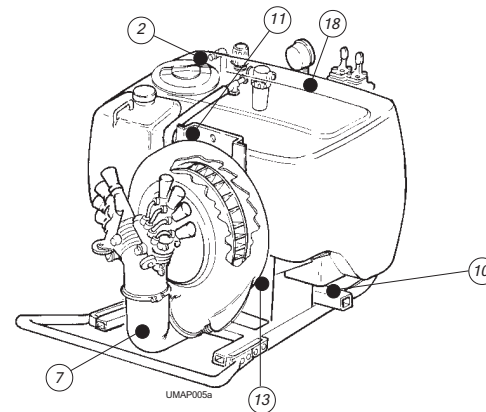
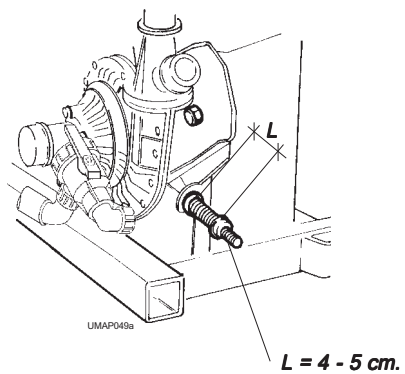

Positions of safety, use and maintenance decals

* Safety

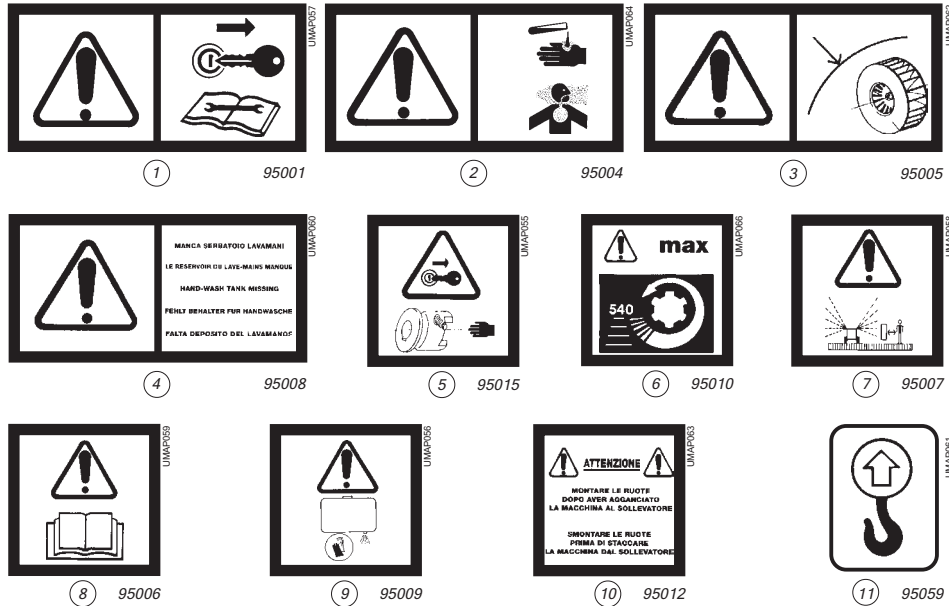

* Use and maintenance

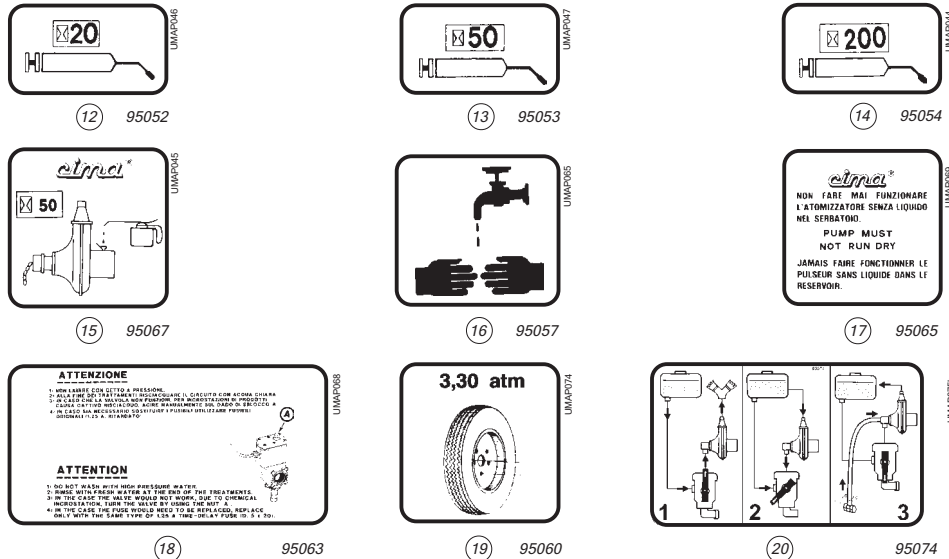

14.2 - CLEANING THE DELIVERY FILTER

1. Bring the lever of the P2 3-ways tap to position "3".
2. Close the P4 knob-valve.
3. Close the cocks of the P7 manual distributor or E7 electric distributor.
4. Loosen the ring nut and remove the cover.
5. Extract the cartridge: clean the net and the sealing O-rings.
6. Introduce the cartridge again and fix the cover by means of the ring nut. Pay attention to the cover O-ring during assembly: a lack in filter seal will compromise the performance of the distribution devices.

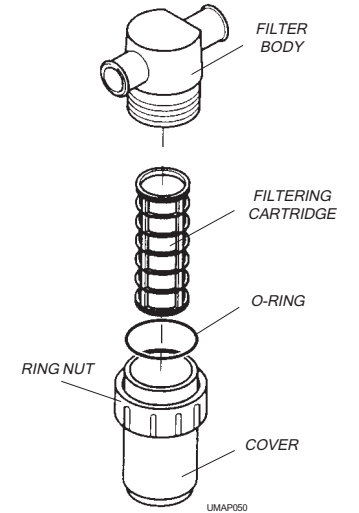

14.3 - CLEANING THE FAN (only for P42E - P45E - P50E)

For the models P55DE and P55DES this operation must be carried out at one of the C.I.M.A. after-sale service centers.

Dirt deposits or incrustations may unbalance the fan, thus causing vibrations.

1. Unscrew the nut fixing the collier.
 2. Remove the collier fastening the fan's guard to the plate of the frame located in the opposite side of the suction grid.
 3. Extract the fan's guard.
- The fan shall never be disassembled.
4. Clean the fan avoiding using jets of pressure water: they may cause infiltrations in the fan's shaft support and damage the bearings.
 5. Re-fit the guard by accurately tightening the screw of the collier.

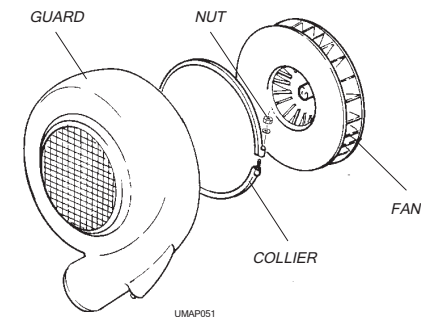

UMAP051

14 MAINTENANCE OPERATIONS 14

 ALL THE OPERATIONS SHOULD BE CARRIED OUT WHEN THE ENGINE IS OFF AND THE IGNITION KEY IS OUT OF THE CONTROL PANEL.

| Parts to be lubricate | Action | Material to be used | Periods |
|----------------------------|-----------|-----------------------------|---------|
| Fan shaft bearing support | Grease | Grease Type EP Class NLGI 2 | 20 h |
| Fan belt tensioner support | Grease | Grease Type EP Class NLGI 2 | 50 h |
| Pump bearing | Lubricate | Engine motor | 50 h |
| Free wheel | Grease | Grease Type EP Class NLGI 2 | 200 h |

14.1 - LUBRICATION

- Accurately clean the grease nipples and the air inlet to avoid introducing dirt during lubrication.
- In case of intensive use of the machine, decrease the lubrication time intervals.

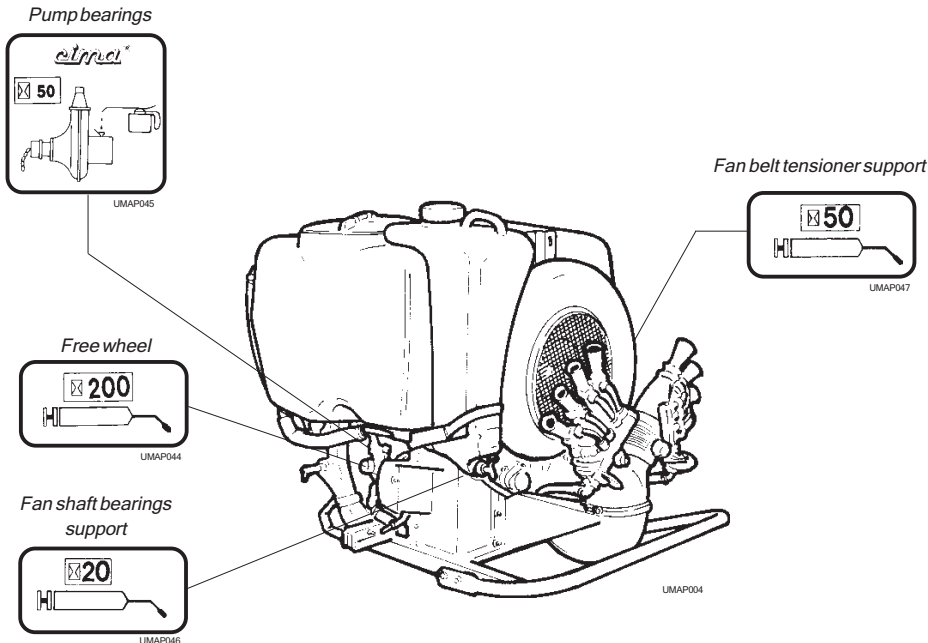

3 GENERAL INFORMATION 3

3.1 - IDENTIFICATION OF THE MACHINE

The identification nameplate form includes the following fields: CE mark, cima S.p.A. logo, address (MONTU' BECCARIA (PV) ITALY), phone and fax numbers, a box for 'Fabbr. nel', and fields for 'Tipo', 'Matr.', 'Press. max bar', 'Peso a V. Kg', and 'Peso T. Kg'.

UMAP001

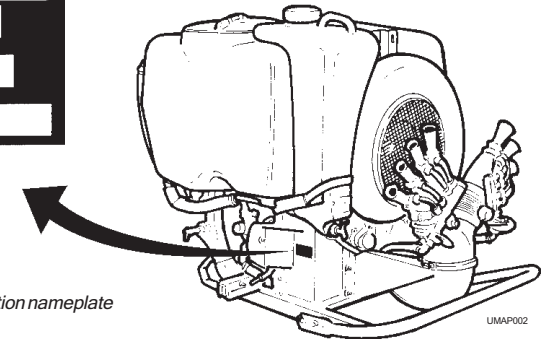

UMAP002

3.2 - TECHNICAL ASSISTANCE

C.I.M.A. S.p.A. is at its customers' full disposal for any kind of assistance. The names and addresses of its assistance centers, in Italy and abroad, may be requested at:

C.I.M.A. S.p.A.- Loc. Molino Quaroni - 27040 MONTU' BECCARIA (PV) - ITALIA
 tel. 0385-246636 - fax 0385-246637
 from abroad: 39-0385-246636- fax 39-0385-246637

3.3 - SAFETY WARNINGS

All of the preparation, use, maintenance, handling and transport operations should be carried out only after having acquired perfect understanding of all instructions contained in this publication and the ability to interpret in the correct way the symbols applied on the machine.

 **IT IS NOT PERMITTED TO USE THE DUSTER FOR PURPOSES OTHER THAN ITS ORIGINAL USE, AS IT HAS BEEN DEVELOPED EXCLUSIVELY FOR DISTRIBUTING INSECTICIDES ON AGRICULTURAL CULTIVATIONS.**

The following general rules must be respected scrupulously:

- always stop the motor before carrying out any operation on the atomizer;
- check that the weight and power of the tractor are compatible with the atomizer to be used;
- before use, check the different components of the machine for correct tightness and fastening, paying special attention to the safety protection devices and the running parts;
- only use U-joints with protection devices accompanied by EC statement of conformity. Carry out the coupling only if the power take-off of the tractor and atomizer is equipped with a counter guard;
- check that the protection device of the U-joint is fastened with the appropriate anti-rotation chains;
- clear people and animals away from the machine before starting it;
- do not wear clothes that could get caught in the running parts of the machine;

– reduce the speed when going over dips in the road or crossing ditches.



- All of the maintenance and repair operations should be carried out only after having carefully cleaned the hydraulic circuit with clean water.
- Before operating into the tank it is necessary to carefully wash it inside with clean water.
- It is forbidden to weld if ammonium salts have been used.
- It is forbidden to use the machine in a potentially explosive atmosphere.
- It is not permitted to spray paints and/or solvents, to wash areas and/or machinery or to utilize the air stream for purposes different from the distribution of agrochemicals.

3.4 - SAFETY DEVICES

All running parts of the machine are adequately protected and indicated with warning decals.



- It is forbidden to use the machine if the protection devices have been removed.
- Before lifting the tank lid or removing the protection devices, stop the motor of the tractor and take the key out of the control panel.

The picture shows the protected parts of the machine:

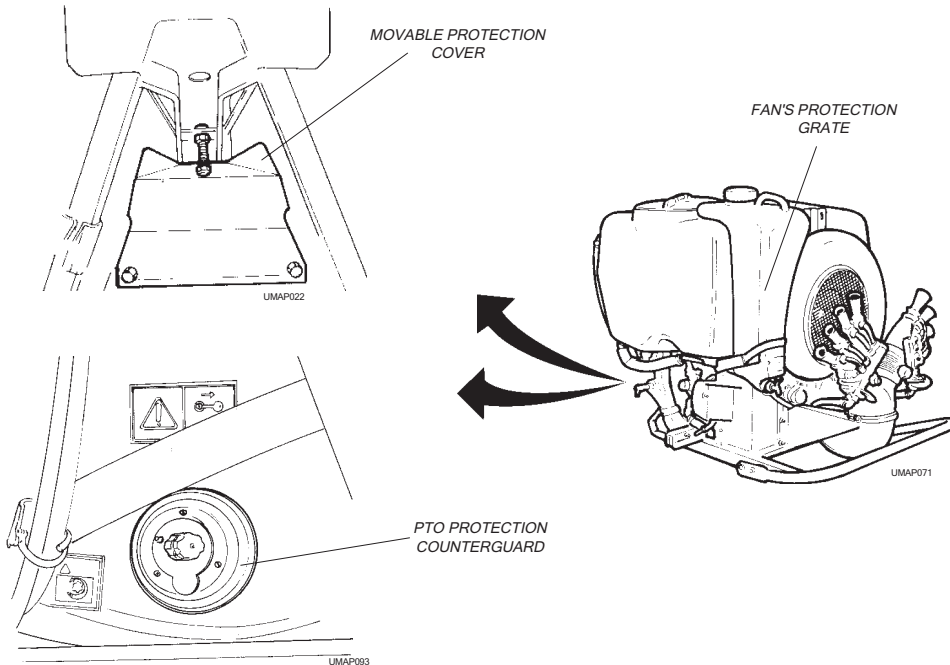

IT IS NOT PERMITTED:

- To transport or lift the sprayer with mixture residues in the tank for purposes different from its original use.
- To transport people, animals or objects.
- To tow vehicles or equipment.



Transport on the road must be carried out respecting the laws of the traffic code valid in the country where the machine is used.

- When the encumbrance of the duster is larger than that of the tractor, it is necessary to display the appropriate "wide load" sign on the back of the machine.
- It is necessary to duplicate the license plate and the rear lights of the tractor if they are covered by the machine.

The operator will be held responsible for non-observance of these laws.

• Lifting and transport of the sprayer



Before carrying out any operation it is essential to check that there are no mixture residues left in the tank.

1. Check that the cables or the chains are adequate for the weight to be lifted (machine - distribution devices - accessories).
2. Hook the machine in the supporting point indicated on the frame by the decal, and check the tightness of all parts involved in the operation.

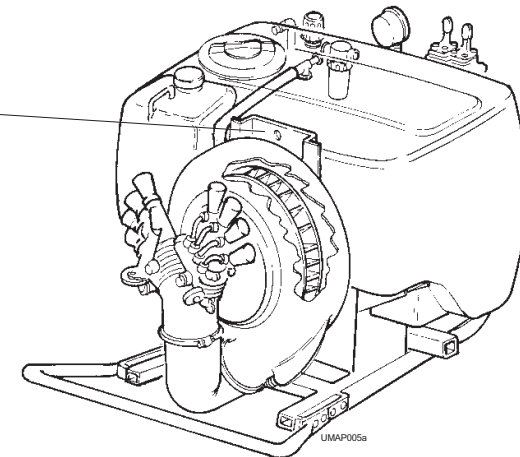
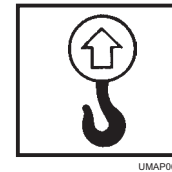

3. Lift the machine making sure it is balanced.
4. Place the sprayer on the means of transport in perfectly stable conditions.
5. During transport the machine must be locked and fastened to the means of transport by an appropriate harness.

- e. Immediately wash all elements contaminated during the treatment, promptly take off the contaminated protection clothes and **discontinue the job if these cannot be replaced.**
- f.  **Immediately clean the clogged jets. Avoid using hard and sharpened tools in presence of calibrated holes.**
- g. If wind increases, follow the instructions given in the preliminary operations (12.1.c).
- h. During the pauses, close all valve, stop the tractor and take the key out of the control panel and drop the hoist.
- i. Pay special attention to treatments near property boundaries, houses, waterways, roads or public paths.

12.4 - END OF TREATMENT - STORAGE

12.4.1 - Daily

- The operator must:
 - a. Wash the machine externally before cleaning the circuit. The sequence of operations will allow possible residues of water to be eliminated from the ventilating guard and from the pipings which bring the air flow to the heads. These operations must be done in a place where the waste water may be collected in a disposal pit.
 - b. Clean the hydraulic circuit, washing the interior of the tank with a jet of clean water then spraying the same on the field where treatment was done. If necessary, repeat this operation.
 - c. Check the efficiency of the distribution device (spray head) and the cleanliness of the pulverization points (diffusers), replacing them if they are damaged or in bad condition.



The cleaning of calibrated orifices must not be done with hard or sharpened tools.

- d. Put the machine in a ventilated place, sheltered from rain and sun; the rays of the sun are the worst enemies of plastic and rubber parts.

12.4.2 - End of seasonal cycle

- The operator must:
 - a. Carry out most accurately the operations described at the end of daily treatments; the hydraulic circuit cleaning must be done at least twice. Check that in no part of the circuit there is product residue.
 - b. Completely empty the hydraulic circuit, paying special attention to the centrifugal pump.



Avoid using antifreeze solutions.

- c. Check the functionality of the components and structures of the machine. In case of negative results, ask for the assistance of one of our after-sale service centers.
- d. Put the machine in a ventilated place, sheltered from rain, frost and rays of sun.



The use of detergent products for cleaning is allowed only following the norms in force. The operator should get the necessary information from the competent authorities.

3.5 - HANDLING OF AGROCHEMICAL PRODUCTS

The **operator** may be contaminated either by contact with or inhalation of the products and mixtures to be distributed. The **environment** may be polluted by the spillage of the products, the careless conservation of empty or unwashed packages, and by pouring the products into the water system. To avoid these risks, the filling operations should be carried out in suitably prepared and adequately equipped areas, or on the treatment site.

3.5.1 - Storage

Permanent/Stationary: the room used should be ventilated and provided with locking doors to prevent the accidental entry of children and unskilled persons.

Mobile: this means of storage should have a lock, to prevent children and unskilled persons from opening it in the absence of the operator. All containers, either full or partially used, must be placed in a way so as not to tip over, fall or break during transport.

Both types of storage should:

- have an appropriate container for storing the empty packages, if a special area is not available;
- have access to clean water for washing, by way of a container or connection to the water supply;
- have access to fire-extinguishers in the presence of inflammables.



- **All containers, either full or partially used, should be kept in their original packaging and their labels should always be legible.**
- **The instructions for storage, use and disposal which are displayed on the original packaging of the products should always be scrupulously respected.**

3.5.2 - Specific equipment

The preparation or filling area must provide:

- all the equipment necessary for measuring the exact quantity of water and of the product to be poured into the tank at each filling;
- all the necessary equipment and tools for preparing the mixture and cleaning the operator in case of contamination;
- all equipment for the easy direct introduction of agrochemical products into the tank;
- a supply of clothes and preventive measures to avoid contamination either by contact or inhalation during the operative stage of the intervention;
- the appropriate equipment for stopping spillage and overflow of the mixture without control;
- a non-return valve on the supply pipe, when the tank is filled with water running directly from the water supply.

3.5.3 - Disposal of empty containers and agrochemical residue

Agrochemicals are classified as "special" waste and their disposal must be different from "urban" waste.



- **The empty packages and the contaminated containers to be disposed of should not be abandoned, burnt or buried in the ground.**
- **The water used for washing the tanks and the equipment used for preparing the mixtures must not be drained onto the ground or poured into channels, streams or rivers.**

The disposal of special waste is regulated by specific norms. To carry out the operation, it is necessary to obtain the appropriate information at the competent local offices. The non-observance of these laws may cause enormous damages to people, animals and the environment.

3.5.4 - Personal protection means

The toxicity of agrochemicals compels people using them to wear adequate protective clothing and accessories to avoid the risks of contamination by contact or inhalation.

The operators must wear:

- Polyethylene or polyvinyl gloves.
- Full body overalls in waterproof cotton, to allow perspiration with side polypropylene coatings. It is possible to find disposable tyvek overalls that, after use (see picture), must be disposed of in the same way as the toxic waste.
- Half-size mask in neoprene rubber with 1 or 2 filters. It is possible to use filters for gas and organic vapors (European class A1) combined with filters against powder (European class P1), for mists and irritating powders, or P2 for mists and harmful or toxic powders.

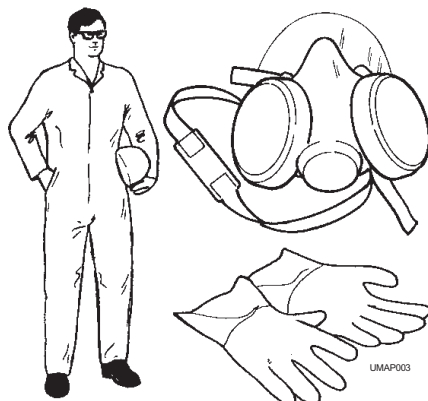

The filters should be replaced:

- when you notice odor/taste of agrochemicals, for class A1 with activated carbon;
- when you feel resistance in the breathing functions, for classes P1 and P2 against powders.

It is, however, necessary to use all personal protection means according to the recommendations of the manufacturer.

- c. Adjust the sprayer according to the parameters calculated during the preliminary operations.
- d. Prepare the mixtures in a well-ventilated place. If this is done outdoors, the presence of wind increases the danger of contamination.
- e. Exactly weigh the previously calculated quantity of product to be mixed at each loading.
- f. Avoid proximity of open flames, live coal or burning objects with flammable products.
- g. In case of mixtures with agrochemical products and fertilizers, to have a correct batching of volume, first dilute the fertilizer.
- h. Wash and rinse the emptied product packages with clean water; collect the water used and pour it into the tank before filling; put the packages in the appropriate container or in the storage room.
- i. Wash the equipment and the tools used for preparation and keep them in the storage area for chemical products.
- l. **Always** leave the product loading and preparation area in conditions which will not cause **any** contamination to persons or animals, and environmental pollution.
- m. After you have loaded the machine, fill the tank for personal cleaning with clean water.
- n. If necessary, mark the field or the machine passage area, to provide a guide for treatment and to avoid missing parts or overlapping layers.



- AT THE END OF THE SPRAYING OPERATION ALWAYS LEAVE THE PREPARATION AREA AND THE SPRAYED AREA CLEAN AND UNPOLLUTED.
- BEFORE RE-STARTING THE TRACTOR, CLEAR PEOPLE AND ANIMALS AWAY AND NEVER LEAVE THE MACHINE UNATTENDED DURING THE PREPARATION OPERATIONS.

12.3 - TREATMENT



IT IS ADVISIBLE TO BEGIN THE TREATMENT AT THE EDGE OF THE FIELD.

• The operator must:

- a. Prior to treatment, agitate the mixture in the tank, by RECYCLING its volume for the time necessary to make it homogeneous.
- b. Stop treatment from time to time, agitate the mixture then re-start treatment. If the re-start is delayed, before beginning check the filter cleanliness and agitate the mixture left in the tank.
- c. After each filling, make sure that the additional hand-wash tank is full of clean water.
- d. Use personal protection identical to those advised for the mixture preparation if the tractor is not equipped with a pressurized cab with aeration filters.

12 PROCEDURES FOR USE 12

12.1 - OPERATIONS PRIOR TO SPRAYING

- **The operator must:**
 - a. Make sure that the conditions, the disease stage or the precautionary measures justify the treatment.
 - b. Be aware of the weather-forecast for the period of time necessary to carry out the treatment.
 - c. If possible, avoid spraying in windy conditions or when mixture begins drifting out of its intended range. It is recommended treatment to be stopped when the wind speed exceeds 3m/sec. (10km/h). In case it is absolutely necessary to carry out the treatment, it is recommended:
 - the distance between the spraying points and the cultivation to be reduced, even if this means having a lower pulverization quality;
 - the drop size to be increased, adjusting the machine accordingly (lower pressure).
 - d. Check that the mixtures of different products are compatible from a physical, chemical and biological viewpoint; if necessary ask the retailer for information.
 - e. Calculate the exact quantity of product needed for treatment and the volume of water to be employed.
 - f. Check that a sufficient quantity of product for the whole treatment is available.
 - g. Carefully read the instructions for the use of the product, to check the conditions for use, the correct batching and the expiration dates.
 - h. Calculate the necessary parameters for adjusting the machine and determine the exact quantity of product to be used for each loading.
See instructions at par. 11.2 and those on the use and maintenance manual of the distribution device.

12.2 - OPERATIONS IN PREPARATION FOR TREATMENT

 **THE LOADING SHOULD BE DONE WITH THE MACHINE ON A FLAT SURFACE. THE QUANTITIES OR THE MIXTURES TO BE POURED INTO THE TANK SHOULD BE PREPARED ON TREATMENT SITE, BEFORE THE OPERATION.**

- **The operator must:**
 - a. Wear adequately protective clothes and accessories, to avoid contamination either by inhalation or by contact with the products used, such as overalls, waterproof jackets, gloves, glasses and masks.
-  - **Powder masks do not offer any protection against toxic vapors.**
- **Avoid using clothes that could get caught in the moving parts.**
- b. Check the filter cleanliness and carry out all checking and maintenance operations necessary for setting up the machine.

4 STRUCTURAL ANALYSIS OF THE MACHINE 4

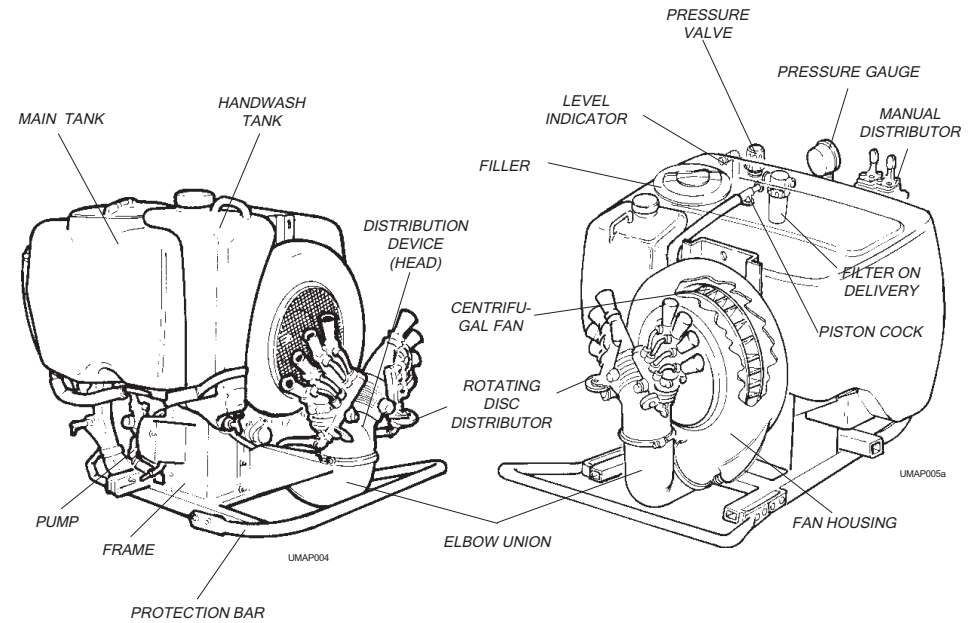

The pictures show the position of the main components of the atomizer.

4.1 - FRAME

The frames of the ranges P42 and P45 may be coupled to hydraulic hoists of class "1". The pins diameter is 22 mm. The pin of the top link is 19 mm dia.

The frames of the ranges P50, P55 and P55S may be coupled to hydraulic hoists of class "2". The pins diameter is 28,5 mm. The pin of the top link is 25 mm dia.

To limit moving the center of gravity and get a functional coupling, all frames allow a double positioning of the pins and two possibilities of connecting the top link. Frames are prepared for being fitted with a protection bar for the distribution devices; this bar shall be mounted in the most efficient position, considering the work conditions and the type of heads employed. A supporting bracket located in the frame front part, allows fitting the transmission joint when the machine is not coupled to the tractor. Under all frames there is an axle enabling fitting a couple of wheels, on request (see accessories installation, Par. 7.2).

4.2 - FAN DRIVE

Drive input shaft

Between the gearbox Pto and the fan control pulley there is a free wheel. In case of sudden decelerations or unexpected motor stop, it permits the fan to continue its free rotation thus avoiding the transmission of violent stresses (see picture) to the organs involved in the movement.

The poly-V belt which transmits the motion to the fan and the "V" belt of the centrifugal pump are equipped with automatic belt stretchers which make maintenance unnecessary.

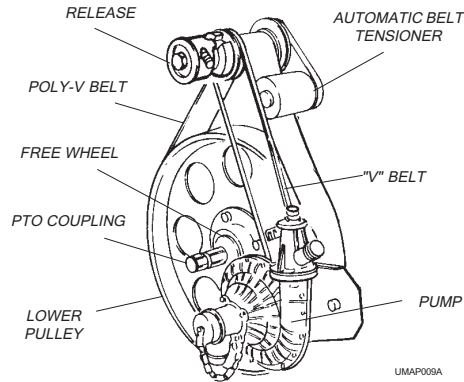

Centrifugal fan

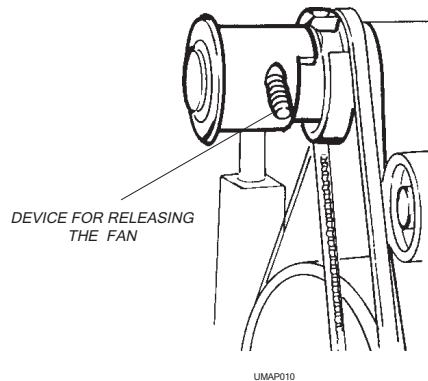
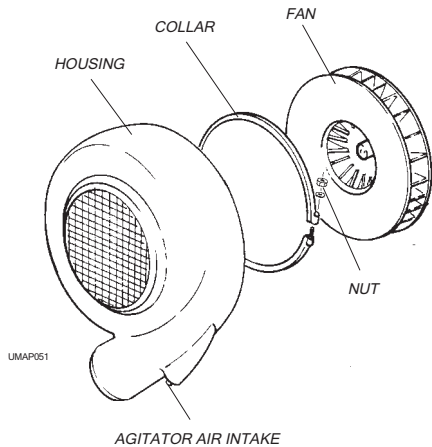

The front release device fitted to the fan shaft allows the running of the centrifugal pump, excluding that of the fan. The fans' guards can turn by 360°. This allows locking the outlet opening in the exact point which is necessary for fitting the various distribution devices.

An air intake on the guard outside the rim allows the pneumatic agitation of the mixture. It is connected to the cock above the tank by means of a pipe.

Centrifugal fan with closed blades, in steel sheet metal.

This information ends with some concise specifications regarding some details which characterize to this treatment technique.

The aim is to draw attention to certain aspects that are not normally considered and stimulate conclusions that must unavoidably be thoroughly explored.

That being stated, it is a good idea for the operator to stop and consider the relationship between the WORKING WIDTH, or the presence of plants with high leaf development and intensity, and the FORWARD SPEED in determining the SPRAYING CAPACITY PER HOUR.

These two parameters must complement each other and keep the capacity within values which guarantee pulverization adequate to the machine functional features. In other words it is opportune to pay attention to the principle that when the working width value increases, the forward speed value must decrease and viceversa. In the latter case it must be recalled that, to achieve the best results, the speed must always be limited.

On the whole it is therefore opportune to select balanced conditions between the forward speed and the be sprayed. The speed must permit penetration in the leaf mass that is to be treated and the volume of mixture to be distributed must be adequate to cover the whole vegetation surface of the plants without causing dripping.

An appropriate pulverization for a low volume treatment requires the original spraying capacity per hour never to be excessive. Therefore avoid high and above the norm forward speeds. Such conditions would imply the use of capacities that the air speed would not succeed in distributing effectively.

| | |
|---|--|
| <p>3 ha/h WORKED SURFACE PER HOUR</p> | <p>To calculate the hectares treated per hour of work multiply the working width (Lm) by the parameter of feed speed (2): (5 m x 0,52) = 2,6 ha</p> |
| <p>4 lt/ha LITRES PER HECTAR</p> | <p>It has been decided to carry out the treatment by using a quantity of water per hectare of = 200 lt</p> |
| <p>5 lt/h SPRAYING CAPACITY PER HOUR</p> | <p>The litres the sprayer must spray in 1 hour of work, essential for adjusting the machine, are obtained by multiplying the surface worked per hour (3) by the stated lt/ha (4): (2,6 x 240) = 520 lt</p> |
| <p>6 ADJUSTMENT OF THE MACHINE</p> | <p>On the capacities table concerning N+N spray heads, look for the value 624 lt (5). Position no. 7 of the adjustment discs, at a working pressure of 1 atmosphere corresponds to this capacity. TO ADJUST THE MACHINE IT IS SUFFICIENT TO POSITION ALL DISCS ON NO. 7 AND CARRY OUT TREATMENT WITH A PRESSURE OF 1 ATMOSPHERE.</p> |
| <p>7 MIXTURE BATCHING</p> | <p>In the treatments made during the previous season 3 Kg per hectare were distributed. With the atomizer you must use the same quantity of agrochemical product that will be distributed with the 240 lt of water selected to treat one hectare and the mixture must be prepared with 1.25 Kg of agrochemical product every 100 lt of water, i.e. 240 lt with 3 Kg of product per hectare. At the end of treatment 2160 lt of water and 27 Kg agrochemical product will have been distributed on the 9 ha of cultivation.</p> |
| <p>VARIANT TO POINT "6"</p> | <p>In case it is decided to carry out the treatment with 300 lt/ha, then the spraying capacity per hour (5) would be 780 lt (300 lt/ha x 2,6 ha). As such value is not listed in the table you must consider the closest one, i.e. 790 lt/h, which recommends the adjustment discs to be set on no. 8 with a working pressure of 2 atmospheres. The new capacity per hour of 790 lt divided by the ha/h worked (3) will give the new quantity distributed per hectare: (790 lt/h: 2,6 ha/h) 304 lt.</p> |

4.3 - HYDRAULIC CIRCUIT COMPONENTS

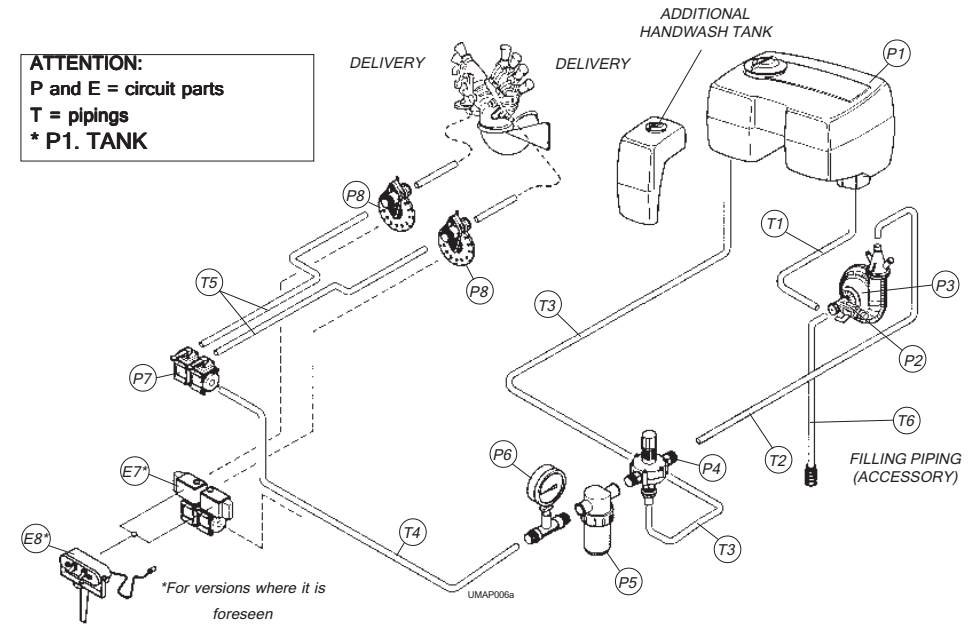

Hydraulic connection diagram

Tanks employed: 200 lt., fibreglass - 300, 400 and 600 lt., polyethylene.

Each tank is complete with:

- threaded tap, 355 mm. diameter, with double breather valve;
- cup plastic filter: outside diameter 302 mm., height 254 mm.;
- two nylon bands with screw hooks for fixing it on the frame;
- external transparent pipe, level indicator, with graduated scale on the tank;
- hydraulic mixture agitator connector to the return piping (T3);

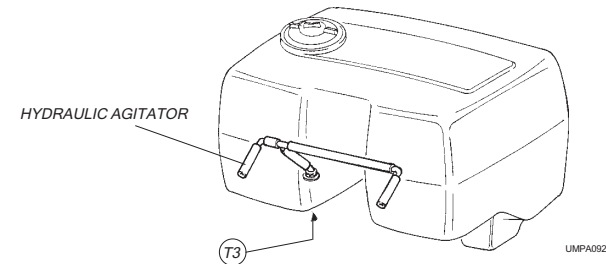

- pneumatic mixture agitator connected to the piston cock situated on the tank, and to the guard air inlet by means of a piping.
- N.B.** The tap is: **a** = open, **c** = closed
- additional polyethylene hand-wash tank with screw cap and service cock: 18 litri

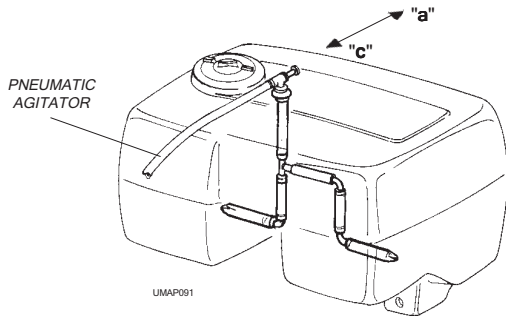

T1. SUCTION PIPING

It connects the tank with the P2 3-way valve, applied to the pump suction coupling.

P2. LEVER THREE-WAYS COCK

Way of the liquid with the cock's lever in position:

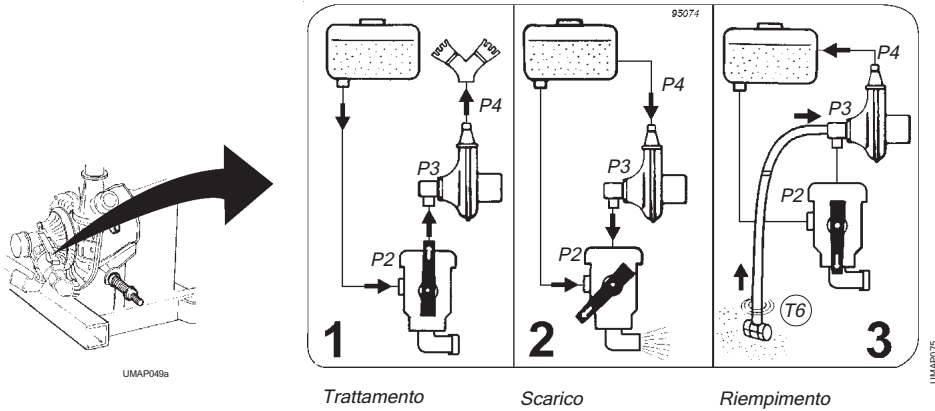

1 TREATMENT POSITION.

From P1 tank the liquid arrives at P2 cock, through T1 pipeline; it is sucked by the pump, sent to P4 with T2 hand grip cock and sent again to the tank with T3 pipeline.

2 UNLOADING POSITION.

The liquid of P1 tank arrives at P2 cock from T1 pipeline and P3 pump, through T2, T3 pipelines and P4 hand grip cock. Taking away P2 cock cap, it effects the unloading of the circuit.

3 FILLING POSITION.

The liquid flow is interrupted from P1 tank to P3 pump.

| TABLE OF CAPACITIES : N+N (*) SPRAYHEAD | | | |
|---|---|------|------|
| With 2 adjustment discs in position: | SPRAYHEAD SPRAYING CAPACITY (lt./h) with PTO at 540 rpm | | |
| | Working pressure kg/cm2 | | |
| | 1,5 | 2 | 2,5 |
| 1 | 67 | 81 | 86 |
| 2 | 107 | 119 | 129 |
| 3 | 119 | 141 | 155 |
| 4 | 167 | 166 | 198 |
| 5 | 219 | 241 | 262 |
| 6 | 243 | 271 | 293 |
| 7 | 371 | 409 | 438 |
| 8 | 457 | 484 | 520 |
| 9 | 547 | 605 | 655 |
| 10 | 643 | 719 | 769 |
| 11 | 852 | 930 | 1002 |
| 12 | 1218 | 1344 | 1471 |
| 13 | 1534 | 1788 | 1957 |
| 14 | 1746 | 2010 | 2285 |
| 15 | 2031 | 2412 | 2687 |

(*) Indicative values given ONLY as an example. For the adjustment of the machine always refer to the "Use and maintenance manual" of the distribution device.

Practical example of adjustment

- A)** Treatment with sprayer (equipped with N+N spray head as per EXAMPLE ABOVE) on 9 hectares of cultivation with rows of 2,50 mt. in which at each passage 2 rows are covered.
- B)** In the treatments performed during the previous seasons, with a traditional normal volume machine, 800 lt. of water and 3 kg. of agrochemical product were distributed, by preparing a mixture with 375 gr. of product for each 100 lt. The treatments required the use of 7200 lt. of water and 27 kg. of agrochemical product.

| | | |
|-------------|----------------------|--|
| Lm | | If at each passage 2 rows of 2,50 mt. distance are covered, |
| 1 | WORKING WIDTH | the working width to be considered is: (2 rows x mt. 2,50) = 5 m |
| Km/h | | |
| 2 | FEEDSPEED | After practical operation on the field, a speed of 5,2 km/h is stated. This value, divided by 10, gives a parameter of = 0,52 |

TABLE SUMMARIZING THE NECESSARY OPERATIONS FOR ADJUSTING THE MACHINE

| 1 TO DETERMINE WORKING WIDTH | 2 TO STATE FORWARD SPEED | 3 TO OBTAIN WORKED SURFACE PER HOUR | 4 TO STATE LITRES PER HECTARE | 5 TO OBTAIN SPRAYING CAPA- CITY PER HOUR |
|--|---|--|---|--|
| distance in metres be- tween the rows multipl. by the number of rows covered at each passage | according to the gear selected to carry out the treatment in km/h, divided by 10 | hectares treated per hour due to the working width multiplied by the feed speed | quantity of water selected to treating the hectare expressed in litres | quantity in litres that the machine must distribute per hour to perform the established treatment |
| Lm | x | $\frac{\text{km/h}}{10}$ | = | ha/h |
| | | | x | l/ha |
| | | | = | l/h |
| 6 MACHINE ADJUSTMENT | | | | |
| <p>In the Table of capacities, supplied with each spray head, look for the spraying capacity per hour obtained (5). Take note of the adjusting disc number, from 1 to 15, and of the working pressure value.</p> <p>If the value of spraying capacity per hour (5) does not coincide with those given in the table, make reference to the closest one. The new value, divided by the worked surface per hour (3) gives the new amount of litres sprayed per hectare.</p> <p>POSITION ALL ADJUSTMENT DISCS OF THE MACHINE ON THE NUMBER FOUND AND CARRY OUT TREATMENT WITH THE CORRESPONDING WORKING PRESSURE GIVEN IN THE TABLE.</p> | | | | |
| 7 MIXTURE BATCHING | | | | |
| <p>The quantity of agrochemical product to be employed must be calculated based on the surface to be treated. Independently from the type of equipment or the litres of water employed, each hectare of cultivation always needs the same quantity of product.</p> <p>FOR EACH HECTARE OF CULTIVATION ONE MUST EMPLOY THE SAME QUANTITY OF PRODUCT DISTRIBUTED DURING THE TREATMENTS OF THE PREVIOUS SEASONS, MIXING IT WITH THE VOLUME OF WATER SELECTED FOR THE TREATMENT.</p> <p>To rationalize the treatment, remember that "quantity distributed per hectare in the previous seasons" means that part of product actually distributed over the cultivation. If it refers to treatments made with normal volume systems, then the dose of agrochemical product per hectare can be reduced.</p> | | | | |

Model C.I.M.A. CD32 - Molded in nylon - Open impeller - Stainless steel shaft - Mechanical seal in silicon carbide and viton - Discharge valve - Suction fitting with additional service union with chain tap. The pump is driven by a "V"-belt, driven by the pulley fitted to the fan shaft.

• T2. DELIVERY PIPING

It connects the P3 pump with the P4 pressure adjustment valve.

• P4. PRESSURE REGULATOR

It is connected with the P5 delivery filter and pipings T2 and T3.

It adjusts the working pressure by controlling the flow returning to the tank.

- It opens when the knob is turned clockwise; the flow returning to the tank increases and the working pressure decreases.
- It closes when the knob is turned counter-clockwise: the flow returning to the tank decreases and the working pressure increases.



The cock must be fully open for mixture agitation and filling operations.

• T3. RETURN PIPING

It connects the P4 valve with the P1 tank at the point fitted with the hydraulic agitator.

• P5. DELIVERY FILTER

It is connected to the P4 cock and the P6 pressure gauge. A ring nut locks the cover to the filter body.

Filter capacity 240 lt./min. - Filtering cartridge: 50 meshes.



A dirty cartridge causes a drop in the working pressure. The problem is indicated by the pressure gauge.

The filter is fitted to the delivery and filters only the supply flow to the distribution devices, thus remarkably reducing the possibility for cartridge clogging.

• P6. PRESSURE GAUGE

In glycerine bath - Dial from 0 to 6 kg/cm² (atmospheres) - adjustment scale 1/10 of atmosphere.



To select the working pressure the valve of the P7 manual distributor or E7 electric distributor must be open.

The pressure must be checked again when it is necessary to operate with a closed valve.

• T4. SUPPLY PIPING

It connects the P6 pressure gauge to the P7 manual 2-way distributor.

It is not employed in the models with E7 2-way electric distributor.

• P7. MANUAL DISTRIBUTOR WITH 2 LEVERS

It is connected to the T4 piping and the two T5 distribution pipings.

It remote controls the spraying opening and closing.

Fix the anchor bracket delivered with the machine onto the tractor, within the driver's reach. During treatment the distributor must be inserted into the fastening bracket by means of its bayonet. When the machine is not coupled to the tractor, the distributor must be set in the appropriate seat on the frame, in the front part of the machine.

Each cock permits spraying from one side only: right or left.

The cock is **open** when the lever is **vertical**, and **closed** when it is **horizontal**.

• E7. ELECTRIC DISTRIBUTOR

It is connected to the P6 pressure gauge, the 2 T5 distribution pipings and to the E8 electric control group fitted to the tractor.

The valve open and close electrically.

Each valve permits spraying from one head side only: **right** or **left**.

• E8. ELECTRIC CONTROL UNIT

It is electrically connected with the E7 distributor and the socket on the tractor. The unit is delivered with a complete socket, in case the one on the tractor is not suitable for connection.

The 2 lever switches, controlling the E7 valves, must be turned to **"ON"** for **opening** and to **"OFF"** for **closing**.

The unit is equipped with a bayonet support, to be inserted in the standard bracket. This bracket must be fixed to the tractor in the reach of the driver. When the machine is not coupled to the tractor, it must be set in the appropriate seat on the frame, in the front part of the machine.

• T5. DISTRIBUTION PIPING

It connects the distributor P7/E7 with the P8 calibration disk adjustment unit, mounted on the distribution devices.

• P8. CALIBRATION DISK ADJUSTMENT UNIT

It selects the necessary deliveries during treatment and is mounted on the distribution devices.

It is made by two flanges, held by two butterfly nuts, locking a disc with calibrated holes, numbered from 1 to 15.

A slot in the disk rim allows the accurate positioning of the hole to be used. Its number must appear in the semicircular seat of the flange. The disk rotation is obtained by unscrewing the wing nuts by a few turns. At the end of the operation carefully rescrew the wing nuts.



ANY LACK IN THE SEAL OF THE HYDRAULIC CIRCUIT MAY CAUSE INTERMITTENT DELIVERY IN SPRAYING. CAREFULLY CHECK THE EFFICIENCY OF GASKETS AND CLAMPS, THE TIGHTENING OF RING NUTS AND UNIONS AND THE INTEGRITY OF THE PIPINGS.

After you have acquired sufficient operative experience, the concentration mixture can be partially modified, to obtain all the advantages offered by a low volume treatment from the sprayer.

In fact, contrary from what was previously said, the quantity per hectare can be reduced by approx. 25% without compromising the result of treatment.

This reduction of doses is suggested to the farmer who understands the functional principles of this technique and its practical possibilities, and wants to finalize his activity in the most economical way. To avoid the perplexities and fears that might be raised by this new operative condition, one must consider the different coverage modalities between the two treatment systems.

— When operating with traditional normal volume machines, the quantity of mixture prepared for treatment is used in an **UNECONOMICAL** way and without evaluating the possible negative consequences for the environment. With this coverage technique, in fact, one has a 25% average loss of the mixture employed, due to dripping on the ground, and dispersion in out-of-target treatment. It is therefore evident that, even with the traditional system, the treatment is made distributing over the vegetation surface only 75% of the prepared volume of mixture, corresponding to a quantity of active principle reduced by 25% with respect to quantity estimated at the beginning. The need to prepare a volume of mixture greater than the real requirements of the cultivation comes only from the coverage technique that, to distribute on the vegetation the necessary dose, i.e. 75% of that quantity, unavoidably disperses the remaining 25%. **"Therefore, of the 3 kg. of agrochemical product per hectare mentioned in the example, only 2250 gr. (75%) will actually be distributed on the plants, and the remaining 750 gr. (25%) will be dispersed in the environment".**

— A correct use of our pneumatic equipment, on the contrary, eliminates this negative aspect and its relevant consequences. The essential characteristics of a low volume treatment is to carry out treatments without mixture dripping or run of. If this happens, it means that the sprayer is not used according to its real operative possibilities. The numerous distribution devices that can be employed on our machines, also eliminate the dispersion effect. They allow, in fact, **"appropriate"** and **"specific" treatments**, as the air flow can be adapted to the shape of plants and the mixture distribution can be differentiated according to the real existing needs in different parts of the same plant. Therefore, with obvious economic advantage, this treatment system permits the reduction of the dose of agrochemical product per hectare normally foreseen, by that 25% subject to "dripping" and "dispersion", without compromising the coverage efficiency. The validity of this method is confirmed by the observation that both systems perform the coverage by distributing over the vegetation surface 75% of the dose indicated at the beginning.

"Reducing the 3 kg. of agrochemical product per hectare, considered in the example, by 25%, the mixture shall be prepared with 2250 gr., that will be fully distributed on the plants. "

TABLE SUMMARIZING THE NECESSARY OPERATIONS FOR ADJUSTING THE MACHINE

AFTER POSITIONING ALL ROTATING DISCS ON THE NUMBER INDICATED, YOU CAN BEGIN THE TREATMENT, BEARING IN MIND THAT THE WORKING PRESSURE VALUE MUST BE THE ONE OBTAINED FROM THE TABLE. THIS VALUE MUST BE SET ON THE PRESSURE GAUGE (P6) WITH THE MANUAL (P7) OR ELECTRIC (E7) DISTRIBUTOR VALVE OPEN.

When the value of the original spraying capacity does not match with those given in the table, you must take into consideration the nearest value and its adjustment data. By dividing this new value by the surface worked per hour (point 3) you will get the new quantity of liters sprayed per hectare. It will not be much different from the one previously stated.

7 Mixture batching

The quantity of agrochemical product to be used in the preparation of the mixture, must be calculated only according to the surface to be treated. INDEPENDENTLY FROM THE TYPE OF EQUIPMENT OR THE LITERS OF WATER EMPLOYED, EACH HECTARE OF CULTIVATION ALWAYS NEEDS THE SAME QUANTITY OF PRODUCT.

Considering that the surface of cultivation being treated is usually always the same, it results that, depending on the moment of treatment, also the quantity of product to be employed does not change and is the same as that employed for the treatments performed during the previous seasons. Therefore, the required quantity of agrochemical product per hectare is a value that can be considered constant and always known by those who carry out treatments.

With our sprayer, the product needed for the treatment may be distributed (see point 4) with a very reduced volume of water with respect to the traditional normal volume apparatuses. This implies the preparation of concentrated mixtures and the smaller the quantity of water used for treatment, the higher the concentration will be.

Here are some examples for preparing the mixture, assuming that one hectare cultivation is to be treated, in which 3 Kg. of product have always been used:

TRADITIONAL NORMAL VOLUME MACHINE

with 3 kg. in 1000 lt/ha = 300 gr. of product in 100 lt. of water
concentration "1 time" = normal volume

PNEUMATIC LOW VOLUME SPRAYER

with 3 kg. in 400 lt/ha = 750 gr. of product in 100 lt. of water
concentration "2.5 times" (1000:400)

with 3 kg. in 300 lt/ha = 1000 gr. of product in 100 lt. of water
concentration "3.3 times" (1000:300)

with 3 kg. in 250 lt/ha = 1200 gr. of product in 100 lt. of water
concentration "4 times" (1000:250)

with 3 kg. in 200 lt/ha = 1500 gr. of product in 100 lt. of water
concentration "5 times" (1000:200)

4.4 - TECHNICAL DATA

4.4.1- Machines dimensions and weights

(With protection bar - without distribution device - without accessories)

| | | Tank capacity (litres) | | | |
|---------------------|-----------------------|------------------------|------|------|------|
| | | 200 | 300 | 400 | 600 |
| P 42 | Total width (mm) | 1000 | 1060 | 1180 | - |
| | Total height (mm) | 1160 | 1140 | 1200 | - |
| | Total length (mm) | 1400 | 1400 | 1400 | - |
| | No-load weight (kg) | 160 | 180 | 188 | - |
| | Full-load weight (kg) | 378 | 498 | 606 | - |
| P45 | Total width (mm) | 1000 | 1060 | 1180 | - |
| | Total height (mm) | 1160 | 1140 | 1200 | - |
| | Total length (mm) | 1400 | 1400 | 1400 | - |
| | No-load weight (kg) | 162 | 187 | 190 | - |
| | Full-load weight (kg) | 380 | 505 | 608 | - |
| P50 | Total width (mm) | - | 1060 | 1180 | 1450 |
| | Total height (mm) | - | 1160 | 1220 | 1285 |
| | Total length (mm) | - | 1550 | 1550 | 1560 |
| | No-load weight (kg) | - | 227 | 230 | 249 |
| | Full-load weight (kg) | - | 545 | 648 | 845 |
| P55 P55S P55E | Total width (mm) | - | - | 1180 | 1450 |
| | Total height (mm) | - | - | 1220 | 1285 |
| | Total length (mm) | - | - | 1620 | 1630 |
| | No-load weight (kg) | - | - | 251 | 270 |
| | Full-load weight (kg) | - | - | 669 | 888 |

UMAPT02

4.4.2 - Fan-pump specifications

- Centrifugal fan

| | MODEL 3 POINT MOUNTED SPRAYER | | | | | |
|----------------------------------|-------------------------------|------|------|-------|-------|-------|
| | P42 | P45 | P50 | P55 | P55S | P55E |
| Fan diameter (mm) | 450 | 450 | 500 | 550 | 550 | 550 |
| Fan speed (RPM) | 3900 | 4500 | 4000 | 3500 | 3700 | 3900 |
| Air capacity (m ³ /h) | 4000 | 5400 | 7550 | 12500 | 14000 | 15500 |
| Air speed (m/s) | 228 | 188 | 179 | 150 | 170 | 180 |
| Absorbed power (kW) | 11 | 17 | 24 | 26 | 34 | 41 |

UMAPT03

• Centrifugal pump CD32

- Speed 4000rpm. P42
- Capacity 120t/min. P42
- Speed.....4250 rpm. P45-P50-P55/S-P55E
- Capacity.....140t/min. P45-P50-P55/S-P55E
- Max. pressure 4,5 Kg/cm²
- Absorbed power kW 2,5



The declared performances can be obtained with PTO at 540 rpm.
This condition must never be exceeded during the use of the machine.

4.4.3 - Fan technical specifications

| | MODEL 3 POINT MOUNTED SPRAYER | | | |
|--|-------------------------------|---------|---------|---------|
| | P42 | P45 | P50 | P55-S-E |
| Steel fan | yes | yes | yes | yes |
| Plastic housing | yes | yes | yes | - |
| 180° elbow union | yes | yes | yes | - |
| Inside diameter of housing outlet opening (mm) | 175 | 175 | 175 | 250 |
| PTO shaft 1"3/8 SAE (DIN 9611/A) | yes | yes | yes | yes |
| Main pulley diameter (mm) | 400 | 450 | 480 | 480 |
| Fan drive belt | 610 J24 | 650 J32 | 690 J50 | 690 J50 |
| Fan pulley diameter (mm) | 54 | 54 | 64,5 | 75 |
| Pump drive pulley diameter (mm) | 78 | 78 | 88 | 101 |
| Pump drive belt | 3V 450 | 3V 450 | 3V 450 | 3V 450 |
| Pump pulley diameter (mm) | 78 | 82,5 | 82,5 | 82,5 |

UMAPT041

at 5 km/h = (5 x 6 mt = 30, divided by 10) 3 worked ha/h

4 Determining the litres to be sprayed per hectare = "l/ha"

After determining the previous parameters it is necessary to find out how many litres of water must be employed to treat one hectare.

This choice, which is limited only by the condition that it ensures the coverage of the cultivation, is left to the user and to his working capacities. From this point of view the options may satisfy every need, even the most difficult one. Normally, our sprayers can perform at 1/4, 1/5 and even 1/10 of the volume required by a traditional normal volume machine.

As an indication, for one hectare of normal orchard approx. 300/350 lt. can be used, while, for a vineyard it is possible to reduce the volume to 100/200 lt. Of course these data represent an average of the values normally used. The choice of the volumes to be used per hectare depends, in fact, on the plant structure, their leaf density and the climatic conditions at the moment of treatment. With high ambient temperatures, the choice of very low volumes is not recommended.

Finally, and in case it is necessary, with our sprayer you can also make selections that allow normal volume treatments.

5 Spraying capacity per hour = "lt/h"

It indicates the litres the sprayer must spray in one hour to carry out the treatment with a stated volume of mixture per hectare.

This parameter has already been substantially defined with the information given above.

BY MULTIPLYING THE HECTARES TREATED PER HOUR (ha/h) BY THE STATED LITRES PER HECTARE (lt/ha) ONE OBTAINS THE SPRAYING CAPACITY PER HOUR (lt/h), according to which the sprayer will be adjusted.

$$ha/h \times l/ha = l/h$$

6 Adjustment of the machine

The regulator(P4), connected to the tank bypass, adjusts the pump discharge flow and, consequently, the treatment working pressure.

By means of the knob it is possible to gradually pass from a zero value of pressure, with open cock, to the max. value, with closed cock. Every change in pressure is shown on the pressure gauge (P6), which allows adjustments of 1/10 of atmosphere.

The adjuster with rotating disc, with 15 calibrated and numbered holes, allows the machine to be used with 15 different capacities, depending on the selected pressure value.

Each distribution device (spray head) comes with a "Use and maintenance manual" in which there is a table showing some pressure values with the 15 corresponding capacities.

Only those values which offer a range of capacities suitable to satisfy every possible operative need are considered.

Look in the table for the value of the spraying capacity per hour determined in point 5: you will see a position number on the rotating disc, from 1 to 15, and a pressure value.

Before finishing it is necessary to point out the importance of the forward speed for a rational and economically profitable treatment. A correct intervention requires that the mixture cloud penetrates the structure of the row, spraying the whole vegetation surface, and that it comes out beyond the plants, avoiding to involve wide areas of empty space. Disregarding this condition causes a dispersion of product. This inconvenience may be avoided by increasing the speed so as to reduce the time of penetration of the air flow in the row and maintain the mixture output within the limits required to avoid product dispersion. When the structural characteristics of the cultivation and the functional ones of the sprayers allow it, the speed may also be reduced. This choice, which increases the time of penetration, must be made only when pulverization can also reach and cover the rows corresponding to those in which the passage occurs.

3 Worked surface per hour = "ha/h"

It is the surface of ground which contains the cultivation covered in one hour of effective treatment.

The idle times for preparation, loading, transfer, etc. are not taken into consideration.

This parameter is easy to determine and you can have it using the two parameters obtained above. It is of fundamental importance because, only by knowing the exact surface worked per hour, it is possible to calculate the quantity of water the sprayer must spray in one hour, in order to carry out the treatment with the selected litres per hectare. In short, to state how many hectares of ground can be worked in one hour, it is sufficient to use the following formula:

$$Lm \times \frac{km/h}{10} = ha/h$$

BY MULTIPLYING THE VIRTUAL WIDTH OF TREATMENT IN METERS (Lm) BY THE FORWARD SPEED IN KILOMETERS PER HOUR DIVIDED BY TEN (km/h: 10) YOU GET THE SURFACE WORKED IN HECTARS PER HOUR (ha/h).

It is obvious that if the working width remains unchanged during the treatment, the worked ha/h changes if the speed is increased or decreased.

If a cultivation has 3 mt distance between the rows, and at each passage 2 rows are covered, the virtual working width of 6 mt (3 mt x 2) always remains unchanged, while the surface worked per hour changes according to the gear selected for treatment:

- at **4 km/h** = (4 x 6 mt = 24, divided by 10) **2,4** worked ha/h
- at **4,5 km/h** = (4,5 x 6 mt = 27, divided by 10) **2,7** worked ha/h

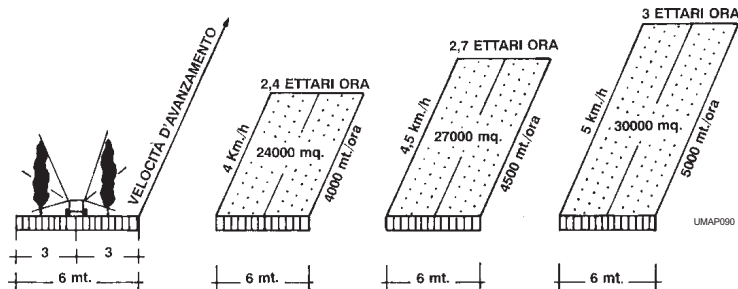

5.1 - TRACTOR HOOK-UP



Check that the "admitted transported weight" and the "admitted rear projection" of the tractor are compatible with the sprayer weight at full load and complete with the equipment for treatment (see paragraphs "3.1" - "4.4.1" and attached documentations).



The tractor's PTO should deliver a power higher than that absorbed by the sprayer under all work conditions.

The atomizer-tractor coupling should be mounted on a flat surface, taking care to clear away all people not involved in the operation, including children and animals.

| To be coupled with tractors of at least | P42 | P45 | P50 | P55 | P55S | P55E |
|---|-----|-----|-----|-----|------|------|
| CV SAE | 25 | 45 | 65 | 70 | 80 | 90 |
| kW | 18 | 33 | 48 | 52 | 58 | 66 |

EXECUTION:

1. Loosen the chains of the 3-point arms.
2. Start the tractor and bring the 3-point arms to the height of the machine gudgeons.
3. **Stop the tractor and take the key out of the control panel.**
4. Fit the pto shaft on the machine side, locking them with the release pins.
5. Take the tension rod off of the tractor's 3rd point and mount it on the machine, locking it with the release pin.
6. Hook the tension back on the tractor, locking it with the gudgeon and the release pin, and screw it slightly to put it in tension.
7. Start the tractor and lift the atomizer until the two PTO's are at the same height.
8. **Stop the tractor, take the key out of the control panel and make sur that nobody touches the hydraulic controls of the 3-point lift.**
AVOID OPERATING OR STAYING UNDER THE MACHINE OR ON THE SURFACE WHICH COULD BE AFFELTED BY A SUDDEN LOWERING OF THE MACHINE.

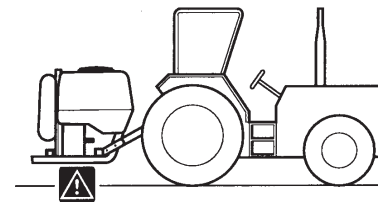

UMAP013

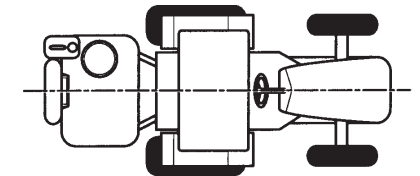

UMAP015

9. By means of the top link, set the axis of the 2 PTO's on the same plane.
10. Lock the 3-point arms by tichening the chains of the 3 point lift.



At the end of the operation the 2 PTO's must be positioned on the same plane.

5.2 - PTO SHAFT



USE DRIVE JOINTS WITH EC CERTIFICATE.
RESPECT THE INSTRUCTIONS CONTAINED IN THE USE AND MAINTENANCE BOOK DELIVERED BY THE MANUFACTURER OF THE JOINTS.



The drive joint must work with the 2 COAXIAL PTOs, or, if this is not possible with PARALLEL axis. In this case, PREVENT the articulation of the drive joint from working with angles wider than 15°.

- Determining the length

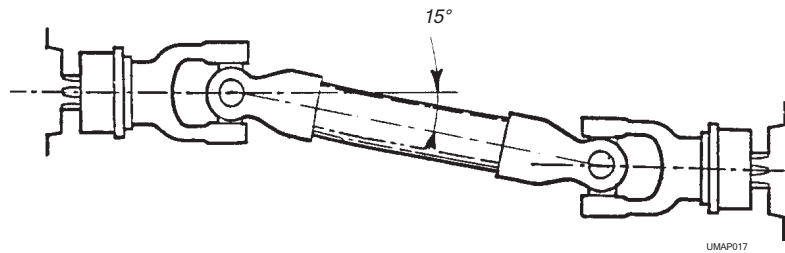

Line the 2 PTOs up perfectly on the same axis and measure the distance "D" between their grooves. The length "L" of the drive joint (see sketch) to be used, measured between the two stop keys and with transmission closed, should be 25 mm shorter than the distance "D".

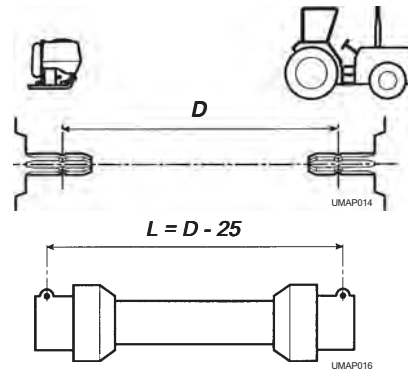

The assembling, disassembling or possible works on the drive joint must be carried out when the engine is stopped and the key is out of the tractor control panel.

3 = THREE ROWS, Lm = 3D (mt 9)

The virtual width corresponds to a strip of land three times as wide as the distance between the rows. It requires a passage every two rows.

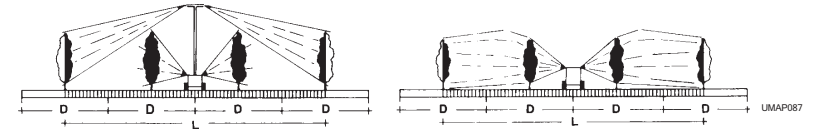

4 = FOUR ROWS, Lm = 4D (mT 12)

The virtual width corresponds to a strip of land four times as wide as the distance between the rows. It requires a passage every three rows.

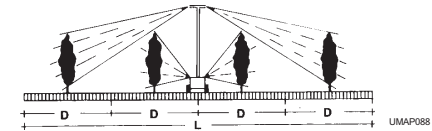

LARGE AREA SPRAYNG

The virtual width corresponds to the distance in meters actually covered by the pulverization.

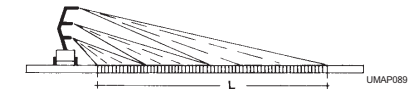

For those who are going to employ an sprayer for the first time, it is suggested that the "virtual width of treatment" be determined after you have verified in practice its coverage capacity. In fact, during the season, this width may change with respect to the moment of treatment: in some cultivations more rows are covered at the beginning of the growing season cycle than those covered during the period of maximum vegetation.

2 Forward = "km/h"

This is the speed of the tractor-sprayer operative unit when carrying out treatment.

It must be decided in practice on the field, depending on the ground conditions, how the cultivation is planted and the type of sprayer employed. It is also essential to select a gear which respects the functional characteristics of the machine. Normally, a speed lower than that used with traditional low volume apparatuses increases the treatment quality and efficiency without reducing its operative capacity.

THE FORWARD SPEED IN km/h IS DEDUCED FROM THE SPEEDS DECLARED FOR EACH TRACTOR, FOR THE GEAR SELECTED FOR TREATMENT, WITH THE PTO AT 540 RPM.

Knowing the length in meters of a row (mt) and calculating the time in seconds (sec) to cover it, it is possible to check or calculate the speed.

It is sufficient to use the formula: "**mt x 3,6 : sec = km/h**" (row length in metres, multiplied by 3,6 and divided for the seconds spent = km/h).

As an example "D" is stated to be 3 mt.

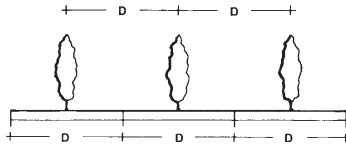

UMAP081

ROWS COVERED AT EACH PASSAGE

0,5 = HALF ROW, Lm = D:2 (mt 1,50)

The virtual width corresponds to a strip of land as wide as half of the distance between the rows. It requires two passages for each row.

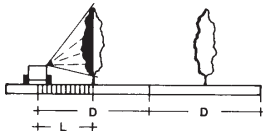

UMAP082

1 = ONE ROW, Lm = D (mt 3)

The virtual width corresponds to a strip of land as wide as the distance between the rows. It requires one passage for each row.

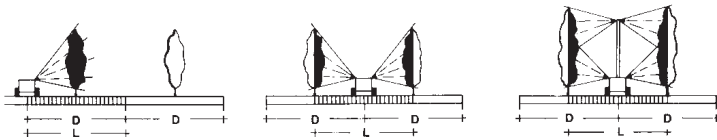

UMAP083

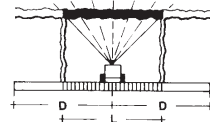
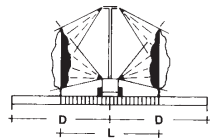

UMAP084

2 = TWO ROWS, Lm = 2D (mt 6)

The virtual width corresponds to a strip of land twice as wide as the distance between the rows. It requires the passage every other row.

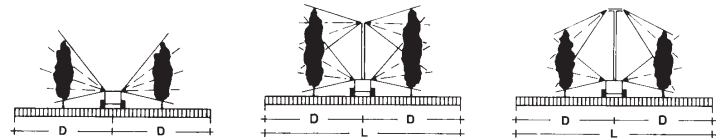

UMAP085

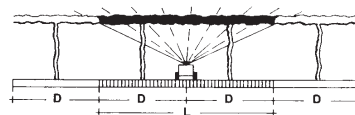
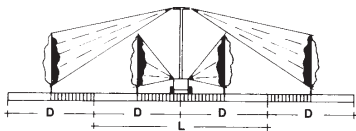

UMAP086

5.3 - INSTALLATION OF REMOTE CONTROLS

5.3.1 - P7 - 2 valve manual distributor

- 1 - Fix the fastening bracket onto the tractor, within the driver's reach.
- 2 - Insert the distributor bayonet support into the fastening bracket.
- 3 - Connect the T5 distribution pipings to the hydraulic circuit of the distribution device (head) fitted to the machine (follow the instructions of the use and maintenance manual supplied by the manufacturer).

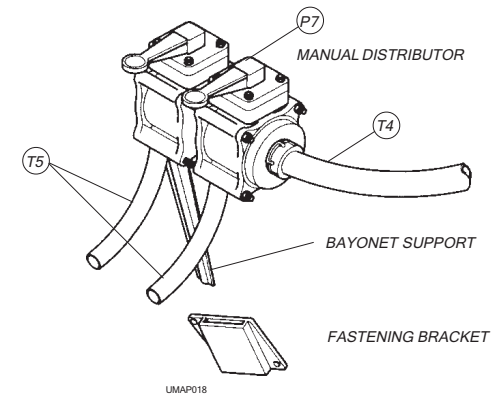

UMAP018



Position the T5 distribution hosing and T4 delivery hosing so as to protect them from damage and breaking during the spraying. If possible use appropriate fastening clamps.

IN CASE OF BREAKAGE:

- 1 - Stop the tractor and take the key out of the control panel.
- 2 - Shut the 2 valve of the "P7" distributor.
- 3 - Put the lever of the "P2" three-way valve in "C" position, i.e. filling.
- 4 - Shut the P4 pressure adjustment knob cock (turn clockwise).

5.3.2 - E8 - Electric control unit

- 1 - Fix the fastening bracket onto the tractor within the driver's reach.
- 2 - Insert the distributor's bayonet support into the fastening bracket.
- 3 - Connect the W1 supply cable by inserting the plug into the tractor socket.



The W1 supply cable is supplied complete with electric socket, to be fitted to the tractors which have none or to replace the existing one if it does not match with the plug.

4. Connect the T5 distribution hosing with the hydraulic circuit of the distribution device (head) fitted to the machine (follow the instructions of the use and maintenance manual delivered by the manufacturer).

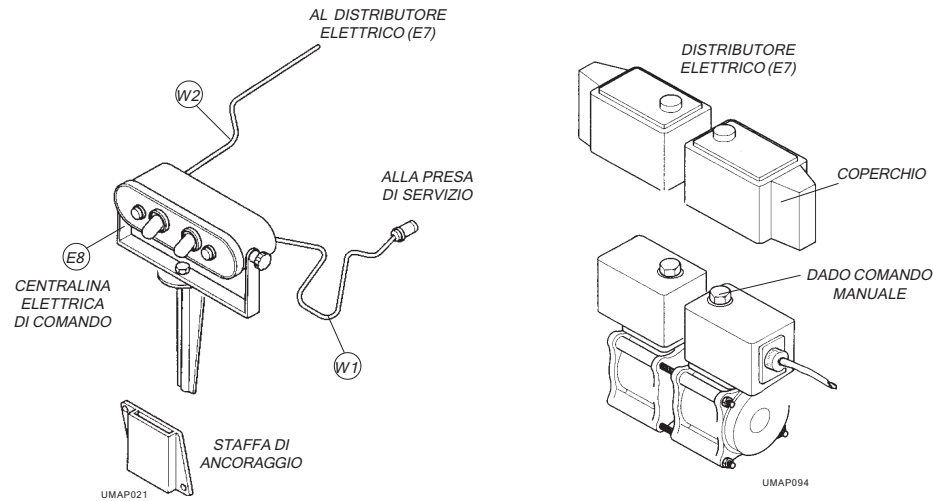

Position the W1 and W2 electric cables so as to protect them from damage during spraying. If possible, use appropriate fastening clamps.

A sudden power cut locks the 2 cocks of the E7 electric distributor. If this happens when the cocks are open, it is necessary to:

- Stop the tractor and remove the key from the control panel.
- Remove the two caps of the E7 distributor.
- Shut the cocks by turning the hexagonal nuts COUNTERCLOCKWISE.

11.2 - DETERMINING THE ADJUSTMENT DATA

The scientific principle of low volume spraying using pneumatic energy for fine droplet creation as used on our sprayers, remarkably enhances the traditional water coverage capacities and ensures, with much reduced water volumes, high-quality applications, which are economically profitable and respond to the present **IMPERATIVE** need to protect the environment against pollution.

Of course, to perform this type of treatment, all sprayers must be duly calibrated before being used. This operation is very simple but can only be done after determining some parameters related to the structural characteristic of the cultivation to be treated and corresponding to the results that must be achieved.

To this aim, it is therefore essential to specify what the parameters are and, moreover, what modalities are to be followed in order to determine them.

1 Virtual width of treatment = "Lm"

This measurement indicates the width of the field including the number of rows treated at each passage.

To make the determination of this parameter easy, it must be considered that each row occupies a strip of land, whose width of which is equal to the distance between the rows.

In a cultivation where the a.m. distance is 3 mt., each row occupies a strip of land 3 mt. wide: 1,5 mt. on one side and 1,5 mt. on the other. If each passage covers 2 rows, corresponding to 2 strips of land, the virtual width of treatment will be 6 mt.

The VIRTUAL WIDTH OF TREATMENT IS therefore OBTAINED by MULTIPLYING THE NUMBER OF ROWS TREATED AT EACH PASSAGE, BY THE DISTANCE IN METERS BETWEEN THE ROWS OF THE CULTIVATION. The calculation must of course also consider the half rows.

Determining this parameter is very simple because it is obtained from the defined and known measures which characterize the cultivation on which treatment shall be carried out.

When distribution devices (spray heads) that cover large areas (tobacco cannon or similar) are employed, the width in meters covered by the spray application must be considered.

To clarify this explanation, a concise illustration of the various possibilities of coverage of the standard available distribution devices is provided. The graphic indications represent the different conditions of the ground, and may help to better understand the modalities for determining this parameter, according to the specific characteristics of each treatment. It must be pointed out that the different possibilities depend on how the cultivation is planted, the structure and development of plants, the configuration of the ground and the power of the available tractor.



- REPRESENTATION OF THE VIRTUAL WIDTH OF TREATMENT = "Lm"

PRELIMINARY CONSIDERATION - "D" indicates the distance in meters between the cultivation rows. This measure is equal to the width of the strip of land occupied by each row.

FOR THE TREATMENT OF THE SAME SURFACE

| | MACHINE USED | PULVERIZATION SYSTEM | PRODUCT EMPLOYED | WATER EMPLOYED | MIXTURE CONCENTRATION |
|------|-------------------|----------------------|------------------|----------------|---------------------------------------|
| 1 ha | AIR-ASSISTED | NORMAL VOLUME | Kg 3 | 1000 lt. | ONCE OR NORMAL = 300 g/100 lt. |
| | PNEUMATIC SPRAYER | LOW VOLUME | Kg 3 | 500 lt. | TWICE OR DOUBLE = 600 g/100 lt. |
| | PNEUMATIC SPRAYER | LOW VOLUME | Kg 3 | 250 lt. | 4 TIMES OR QUADRUPLE = 1200 g/100 lt. |

UMAPT091

| | |
|--|---|
| <p>NORMAL VOLUME Treatment of 1 hectare with 1000 lt. of water and 3 Kg of product.</p> | <p>LOW VOLUME Treatment of 1 hectare with 3 Kg of product. The concentration of the mixture is to be selected, depending on the lt./ha to be employed.</p> |
| <p>AIR-ASSISTED 1000 lt</p>  | <p>PNEUMATIC SPRAYER 250 lt</p>  |
| <p>Mixture concentration: Once or normal.</p> | <p>Mixture concentration: 4 times or quadruple.</p> |

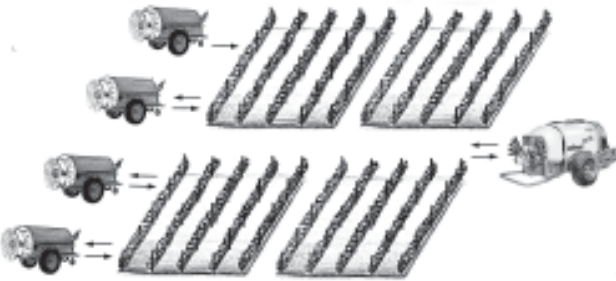
| | | |
|---|---|---|
| <p>AIR-ASSISTED 1000 lt</p> <p>Water employed 4000 lt 4 loadings</p> | <p>COVERAGE OF 4 HA with 12 Kg of product</p>  | <p>PNEUMATIC SPRAYER 1000 lt</p> <p>Water employed 1000 lt 1 loading</p> |
| <p>Mixture concentration: Once or normal.</p> | <p>Mixture concentration: 4 times or quadruple.</p> | |

UMAP092

6

DISTRIBUTION EQUIPMENT

6



Each distribution device is supplied with its USE and MAINTENANCE manual which must, or shall be, considered as an enclosure to this publication.

6.1 - TYPES AND IDENTIFICATION CODES

| Distribution device - spray head | P42 | P45 | P50 | P55 | P55S-E |
|---|----------------|-----------------|----------------|----------------|----------------|
| 4+4 diffuser sprayhead with 8 taps | T.4+4.42.01 | T.4+4.45.01 | T.4+4.50.01 | - | - |
| Strasbourg type sprayhead with 4+4 diffusers and 8 taps | T.ST4.42P.01 | T.ST4.45P.01 | T.ST4.50P.01 | - | - |
| 5+5 diffuser sprayhead with 10 taps | T.5+5.42.01 | T.5+5.45.01 | T.5+5.50.01 | - | - |
| Tendone sprayhead with 7 diffusers | T.TND.42.01 | T.TND.45.01 | T.TND.50.01 | - | - |
| Multiple sprayhead for olive-tree with 4 diffusers | T.OL.000.42.01 | T.OL.000.45.01 | T.OL.000.50.01 | T.OL.000.55.01 | T.OL.000.55.01 |
| Multiple sprayhead for olive-tree with 4 diffusers and 45° elbow | T.OL.045.42.01 | T.OL.045.45.01 | T.OL.045.50.01 | T.OL.045.55.01 | T.OL.045.55.01 |
| Multiple sprayhead for olive-tree with 4 diffusers and 180° elbow | - | - | - | T.OL.180.55.01 | T.OL.180.55.01 |
| Flexible cannon | T.GCF.42.01 | T.GCF.45.01 | T.GCF.50.01 | - | - |
| Vertical cannon | - | - | - | T.GCV.000.01 | T.GCV.000.01 |
| Vertical cannon with 45° elbow | - | - | - | T.GCV.045.01 | T.GCV.045.01 |
| Tobacco canon | T.GC.00.42P.02 | T.GC.00.45P.02 | - | - | - |
| Tobacco cannon with 45° elbow | T.GC.045.42.02 | T.GC.045.45.02 | - | - | - |
| Tobacco cannon(multiple distribution device) | - | - | T.GC.00.50P.02 | T.GC.00.55P.01 | T.GC.00.55P.01 |
| Tobacco cannon(multiple distribution device) with 45° elbow | - | - | T.GC.045.50.02 | T.GC.045.55.01 | T.GC.045.55.01 |
| Tobacco cannon(multiple distribution device) with 180° elbow | - | - | - | T.GC.180.55.01 | T.GC.180.55.01 |
| Rotating group with manual control device | T.GIR.M.175P | T.GIR.M.175P | T.GIR.M.175P | T.GIR.M.250P01 | T.GIR.M.250P01 |
| Rotating group with electric control device | T.GIR.E.175P | T.GIR.E.175P | T.GIR.E.175P | T.GIR.E.250P01 | T.GIR.E.250P01 |
| Manual 5m. air-boom with 8-2 diffuser outlets | BM.08.2.01 | - | - | - | - |
| Manual 7m. air-boom with 10-2 diffuser outlets | - | BM.10.2.01 | - | - | - |
| Hydraulic 10m. air-boom with 16-2 diffuser outlets and levelling piston | - | - | B16.2.66.50.01 | - | - |
| Hydraulic 12m. air-boom with 18-2 diffuser outlets and levelling piston | - | - | B18.2.66.50.01 | B18.2.66.55.01 | B18.2.66.55.01 |
| 2 fishtail sprayhead | - | T.2VS.45P.02 | T.2V.50P.01 | T.2V.55P.01 | T.2V.55P.01 |
| 4 fishtail sprayhead | - | - | T.4V.50P.02 | T.4V.55P.02 | T.4V.55P.02 |
| Potatoe sprayhead with 180° elbow | - | - | - | T.PT.55P.02 | T.PT.55P.02 |
| Tomatoe sprayhead with 180° elbow | - | - | - | T.PM.55P.02 | T.PM.55P.02 |
| 2hands+2 cannons sprayhead | - | TC.2M2C.45P.01 | TC.2M2C.50P.01 | TC.2M2C.55P.01 | TC.2M2C.55P.01 |
| 2hands+2 flexible cannons sprayhead | - | TCF.2M2C.45P.02 | CF.2M2C.50P.02 | CF.2M2C.55P.02 | CF.2M2C.55P.02 |
| 2hands+4 flexible cannons sprayhead | - | TCF.2M4C.45P.02 | CF.2M4C.50P.02 | CF.2M4C.55P.02 | CF.2M4C.55P.02 |
| 2hands+4 cannons sprayhead | - | T.2M4C.45P.01 | T.2M4C.50P.01 | T.2M4C.55P.01 | T.2M4C.55P.01 |

UMAPT093

6.2 - ORIENTATION OF THE FAN-HOUSING

The outlet opening of the fan must be positioned depending on the distribution device to be mounted and on the mode of use. This is possible because the fan housing can rotate on his axe by 360°.

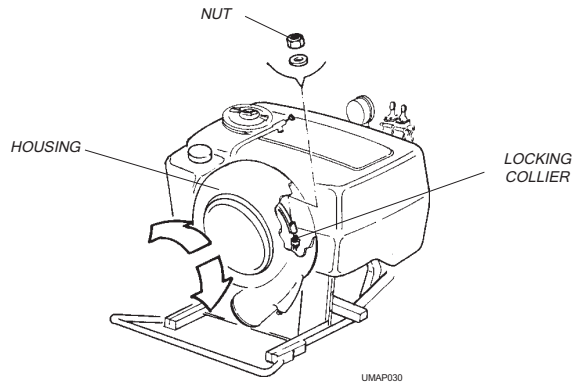

ORIENTATION OF THE GUARD:

1. Place the atomizer on the ground (in case it is mounted on the tractor)



Stop the tractor and remove the key from the control panel.

2. Unloose the collier, supporting and fastening the guard to the frame, situated on the side opposed to the suction grate, by unscrewing the screw.
3. Turn the guard and set the outlet opening on the position necessary for fitting the distribution device (see instructions in the use and maintenance manual of the distribution device).
4. Then lock the collier again.

6.3 - ELBOWS FOR THE DISTRIBUTION DEVICES

The elbow unions support and connect the distribution devices to the fan guard. Some models are fitted to the machine as standard accessories (see paragraph 4.4.3); the others must be delivered with the distribution devices, provided they are not already available.

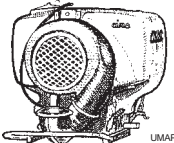
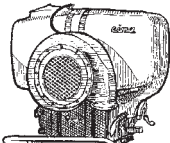
| COMPLETE RANGE | P42 - P45 - P50 | P55 - P55S - P55E |
|--------------------------|---|---|
| BASIC MODEL OF THE RANGE |  |  |
| FAN DELIVERED | WITH 180° ELBOW | WIHTOUT ELBOW |
| OUTLET OPENING | HORIZONTAL | RADIAL |



The use and maintenance manual of each distribution device gives the necessary type of elbow union and the assembling instructions.

It is easy to understand how it is possible, making smaller drops of one drop, to double, triplicate or quadruple its initial coverage. It is also easy to understand how, having a certain quantity of water at our disposal, the coverage possibilities are different and strictly bound to the capacity of "pulverization" of the machine employed.

The diameter of the produced drops is of fundamental importance and can be explained with the following physical observation: "1 lt. of pulverized liquid (1 dm³) may cover a surface of 1 hectare with a density of 20 drops per cm², if their diameter is 100s micron (pneumatic sprayers). If this diameter increases up to 300 microns (air-assisted) the number of drops per cm² will only be 0,7".

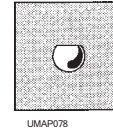

1 l/ha with Ø 300 microns = 0,7 drops per cm² (NORMAL VOLUME)

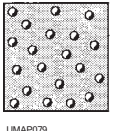

1 l/ha with Ø 100 microns = 20 drops per cm² (LOW VOLUME)



We recall to you that the QUANTITY OF AGROCHEMICAL PRODUCT to be distributed per HECTARE, depending on the cultivation to be treated, REMAINS UNCHANGED, independently from the type of machine employed. It can be deduced from the tables printed on the product packages and from the quantity of water used for "that" surface in the previous treatments.

WITH THE SAME VOLUME OF WATER

| TANK CAPACITY litres 1000 | MACHINE USED | PULVERIZATION SYSTEM | PRODUCT EMPLOYED | SURFACE SPRAYED | MIXTURE CONCENTRATION |
|---------------------------|-------------------|----------------------|------------------|-----------------|---------------------------------------|
| | AIR-ASSISTED | NORMAL VOLUME | KG 3 | 1 ha | ONCE OR NORMAL = 300 g/100 lt. |
| | PNEUMATIC SPRAYER | LOW VOLUME | KG 6 | 2 ha | TWICE OR DOUBLE = g/100 lt. |
| | PNEUMATIC SPRAYER | LOW VOLUME | KG 12 | 4 ha | 4 TIMES OR QUADRUPLE = 1200 g/100 lt. |

11 ATOMIZER ADJUSTMENT 11

11.1 - BASIC INFORMATION: "LOW VOLUME"

It is commonly known that to use agrochemical products, in spite of the development of appropriate instruments, we have always been obliged to use water as the carrying liquid, to obtain an adequate cultivation coverage. Its "droplet creation" in very small drops is the only way to complete a homogeneous distribution of small quantities of active principles over wide vegetation surfaces.

The measuring unit of the diameter of drops obtained is the MICRON, which is the thousandth part of a millimeter:

$$\text{MICRON} = \frac{1 \text{ mm}}{1000}$$

The traditional system to obtain this transformation of the water, usually called "NORMAL VOLUME" consists in forcing water at high pressure through one or more orifices of a very small diameter. By this principle knapsack pumps, pressure pumps and diaphragm or piston pumps, used for hydraulic and air-assisted sprayers and air assisted are being manufactures.

Another system of droplet creation was then developed, based on the "Venturi tube" principle. It consists in creating a very strong air stream, directing it into a tube and letting it out through a suitable narrow passage.

The water, without pressure, is introduced into the center of this narrow passage where it is atomized, as a consequence of the air speed. This principle is the essence behind the design of pneumatic sprayers.

Appropriate and specific technical checks have brought to light the considerable difference in the diameters of the drops produced by these two "pulverization" systems. In the "normal volume" (turbosprayers) 85% of the drops have a diameter of 250/300 microns, and this value cannot be reduced even increasing the working pressure. The second system (pneumatic sprayers) creates a cloud of water where 90% of drops have a diameter of 50-100 microns.

This considerable pulverization difference is fundamental! It allows the pneumatic sprayers, using an equal volume of water, to have a remarkably higher coverage with respect to the traditional pumps. In other words, the sprayers can cover the same vegetation surface treated by the "normal volume" machines, but with a considerably lower quantity of water, i.e. with a "LOW VOLUME" of water.

To figuratively express this concept, let us consider water drop "A", represented, for easier illustration as a square with 6 cm. sides.

The contact side is 6 cm.

From the same square "A" we have obtained 4 squares with 3 cm. sides, thus obtaining a contact line of 12 cm.

Once again from square "A" we have obtained 9 squares with 2 cm. sides, thus bringing the contact line to 18 cm.

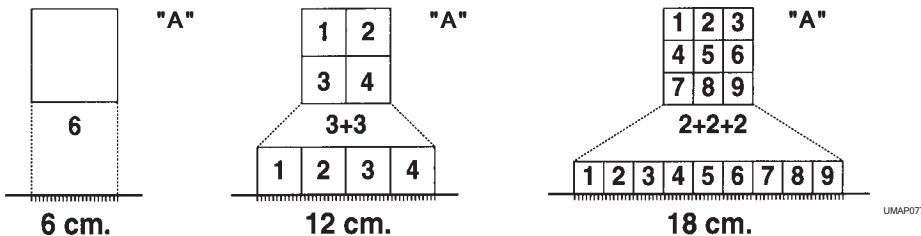

7 ACCESSORIES 7

7.1 - SELF FILLING DEVICE

This piping is complete with a coupling and a filter with foot valve for suction and is used fill the tank. It must be screwed on the P3 pump suction coupling .



The assembling should ALWAYS be carried out when the "P2" tap lever is in "3" position.



Before use, check the seal and see whether the foot valve is working correctly by pouring some water into the hose.

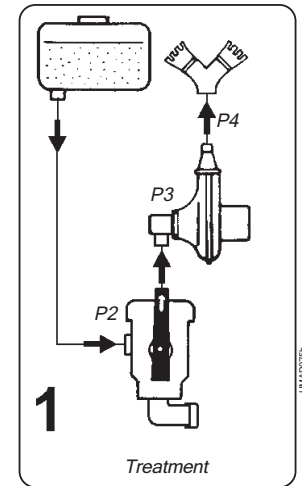
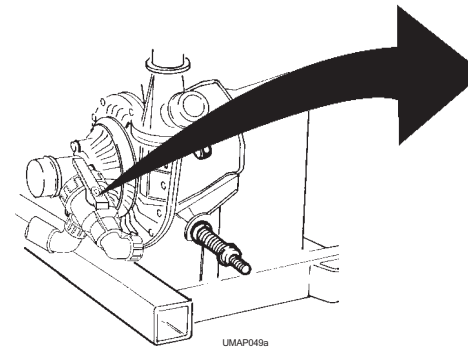

7.2 - COUPLE OF WHEELS

The wheels track can be adapted to the tractor's track.



FIT THE WHEELS AFTER HITCHING THE MACHINE TO THE HOIST.
REMOVE THE WHEELS BEFORE SEPARATING THE MACHINE FROM THE HOIST.

EXECUTION:

1. Hitch the machine to the tractor and lift it till it is possible to fit the wheels.



Stop the tractor, remove the key from the control panel and make sure that nobody can touch the hydraulic controls of the hoist.

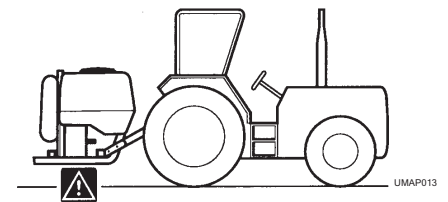

AVOID OPERATING OR STAYING UNDER THE MACHINE OR ON A SURFACE WHICH COULD BE INTERESTED BY ITS SUDDEN LOWERING.

3. Introduce the wheels axle shafts into the machine axle.
4. Adapt the track to the tractor's track.
5. Lock the axle shafts by means of the axle screws.
- 6 Start the tractor, leaving the wheels in raised position in case of transport; lower them for treatment.

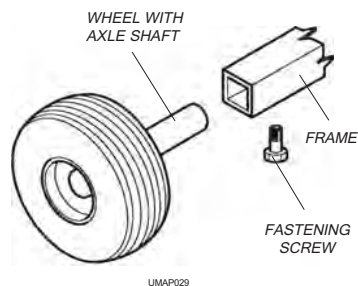

 **THE WHEELS MUST BE RAISED AT EACH CHANGE OF DIRECTION.**

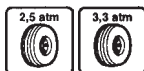

| | P42 | P45 | P50 | P55 | P55S | P55E |
|------------------------------|---------|-----|-----|--------|------|------|
| Tyres size | 5,50-12 | | | 175-13 | | |
| Tyres pressure (atm) | 3,3 | | | 2,5 | | |
| Weighth tyres with axle (Kg) | 37 | | | 41 | | |

UMAP7071

The working pressure of tires is given on the adhesive placed on the frame, near the axle.

7.3 - CRANK CONTROLLED ROTOR

 To fit it a 45° elbow union is necessary.

It is an accessory used to modify the spraying direction. It may be used with only a few types of distribution devices.

 All indications and instructions can be found in the use and maintenance manual of the distribution devices with which this group may be used.

7.4 - ELECTRIC SWIVELLING DEVICE

It is an accessory used to modify the spraying direction. It may be used with only a few types of distribution devices.



 All indications and instructions can be found in the use and maintenance manual of the distribution devices with which this group may be used.

The hydraulic and the pneumatic circuit mounted inside the tank, allow a double agitation system: with the water from the pump and with the air from the fan at the same time. The pneumatic circuit can be excluded when the product has a high foaming effect. When opening it again, check that the air outlet holes are not clogged.

 **Before beginning the treatment it is essential to agitate the mixture in the tank recycling its volume for the time necessary to make it homogeneous.**

-  - The agitation should take place with the pressure adjustment knob cocks (P4) and the piston cock on the tank completely open.
- This operation is essential to obtain a uniform distribution of the active ingredients over the whole vegetation surface to be sprayed.

In case of a short break in the treatment, keep the agitation running till it is re-started. In case of a long break, before re-starting duly agitate the mixture left in the tank.

-   - Stop the tractor and take the key out of the control panel.
- Wearprotective clothing and accessories to avoid risks of contamination by contact or inhalation of the mixture.
- Empty the tank and clean the hoses in an area suitably prepared and adequately equipped for collecting the waste liquid.

This operation is carried out by means of the 3-ways tap (P2):

1. open P4 hand grip cock.
2. take away the cap of P2 cock to the extremity of curve fitting, while the lever in position "1".

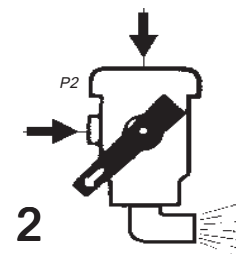

At the end of discharge, screw the cap with chain back in.

12. Pour the necessary quantity of insecticide and the possible water used to wash the product packages and the tools used for preparation.
13. At the end of filling to close the adjustment valve (P4).
14. Disengage the PTO. Remove the filling piping from the pump and re-fit the tap with chain.
15. Re-open P4 hand grip cock and turn the lever of the tap P2 on position "1".
16. To close the mobile protection cover of the tank.
17. Engage the PTO by turning the knob counter-clockwise.

ON TREATMENT SITE:

18. Disengage the PTO and lean the machine on the ground.

19.   **Stop the tractor and take the key out of the control panel. CHECK THAT THE FAN HAS STOPPED.**

20. Engage the fan in the gearbox: follow the instructions given in point 8.1, **pushing** the front body instead of pulling it.
21. Shut the mobile protection cover, start the tractor and lift the machine. Insert the Pto and, keeping it at 500 rpm, make another agitation.
START THE SPRAYING.

FILLING OPERATION SHOULD BE CARRIED OUT WHEN THE MACHINE IS ON A FLAT SURFACE. ON THE TREATMENT PLACE, BEFORE THIS OPERATION, PREPARE THE QUANTITIES OR THE MIXTURES TO BE POURED INTO THE TANK.



IT IS ALWAYS NECESSARY TO USE PERSONAL PROTECTIVE MEANS CLOTHING, GLOVES ETC.

8.1 - INTRODUCTION - USE OF THE FAN RELEASE





The tank filling and the mixture agitation outside the cultivations cannot be done without the help of the fan release.

The frontally restrained disengagement is fitted to the fan shaft and is situated on the machine front part, under the tank.

• Releasing the fan for filling operation

EXECUTION:

1. Bring the atomizer on the filling site and lean the machine on the ground.
2.   **Stop the tractor, take the key out of the control panel and check that the fan has**

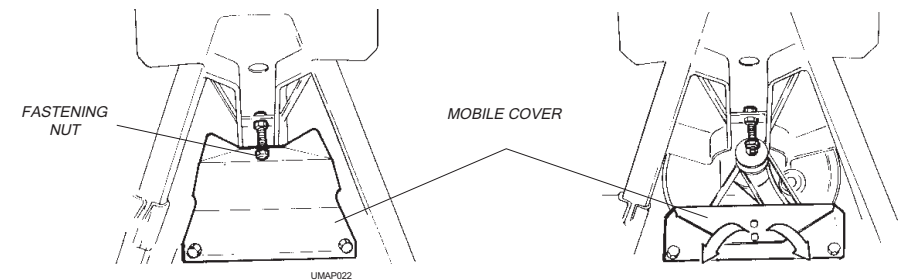

stopped.

3. Lower the mobile protection, cover by unscrewing the nut fastening it to the frame.
4. Press the spring push-button till the end and pull the front body until it is again released outwards. The released body should turn free: then the pump runs and the fan is excluded.
5. Lock the mobile cover to the frame, fastening it with the nut.
6. Start the tractor, lift the atomizer to position the joint and begin filling.

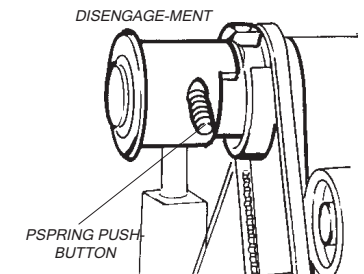

8.2 - USING THE TANK FILLER OPENING (LID).



The orifice of the inlet piping should never come into contact with the insecticide mixture: **IT MUST ALWAYS BE KEPT AT A CERTAIN HEIGHT OVER THE TANK OPENING AND MUST BE EQUIPPED WITH A NON RETURN VALVE.**



THE PUMP MUST NEVER RUN WITHOUT LIQUID.

EXECUTION:

1. Release the fan: follow the instructions given at point 8.1.
2. Turn the lever of the 3-ways tap (P2) on "a" position..
3. Shut the valve of the 2-ways distributor:
 - a. if it is handoperated (P7), put them in horizontal position;
 - b. if it is electric (E8), put the release switches on "OFF".
4. Completely open the adjustment tap (P4), by turning the knob counter-clockwise.
5. Pour water into the tank (approx 1/3 of its capacity).

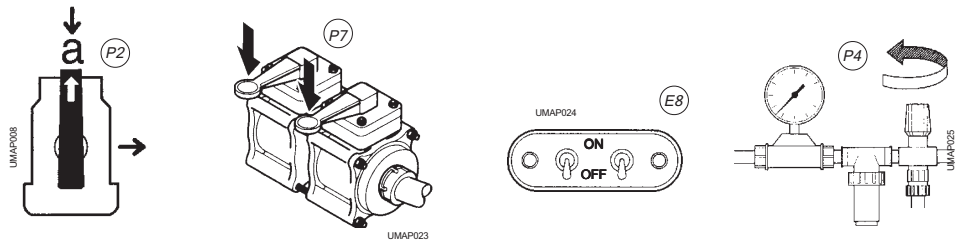

6. Start the tractor, respecting the safety norms, and lift the atomizetr in working position. Engage the PTO and keep it at 500 rpm.
7. Pour the necessary quantity of insecticide and the possible water used for washing the product packages and the tools used for preparation.
8. Finish filling and carefully screw the tank cover.
9. Keep on agitating the mixture in the tank and bring the sprayer to the area to be treated.

ON TREATMENT SITE:

10. Disengage the PtO and lean the machine on the ground.

11. **Stop the tractor and take the key out of the control table. CECK THAT THE FAN HAS STOPPED.**

12. Engage the fan in the gearbox: follow the instructions given at point 8.1, **pushing** the front body instead of pulling it.
13. Shut the mobile protection cover, start the tractor and lift the machine. Engage the PTO and carry out another agitation, keeping the PTO at 500 rpm.
START THE TREATMENT.

8.3 - WITH SELF- FILLING DEVICE



Before use, check the foot valve operation and seal, by pouring some water into the hosing.



THE PUMP MUST NEVER RUN WITHOUT LIQUID.

EXECUTION:

1. Release the fan, follow the instructions of point 8.1.
2. Turn the lever of the 3-ways tap(P2) on **position "3"**.
3. Shut the valve of the 2-ways distributor:
 - a. if it is handoperated (P8), put them in horizontal position;
 - b. if it is electric (E8), put the release switches on "OFF".

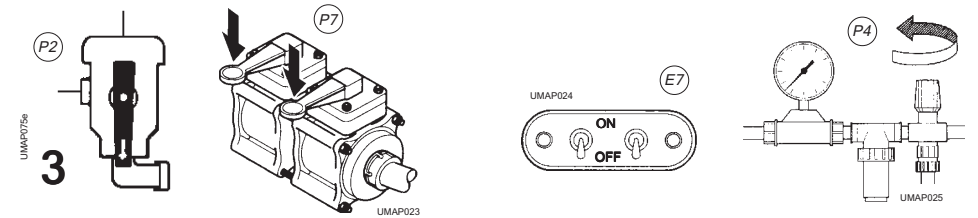

4. Completely **open** the adjustment valve (P4), by turning the knob counter-clockwise.
5. Screw the self-filling device on the pump P3, instead of the tap with chain
6. Plunge the filter into the water to be loaded.



The filter must always be under the water level. The piping never must exceed the pump suction point and should never be "kinked".

7. Place the lever of the 3-ways tap (P2) on **position "1"**.
8. Pour 15/20 lt. of water into the tank, to FILL the HOSE and prime the centrifugal pump.

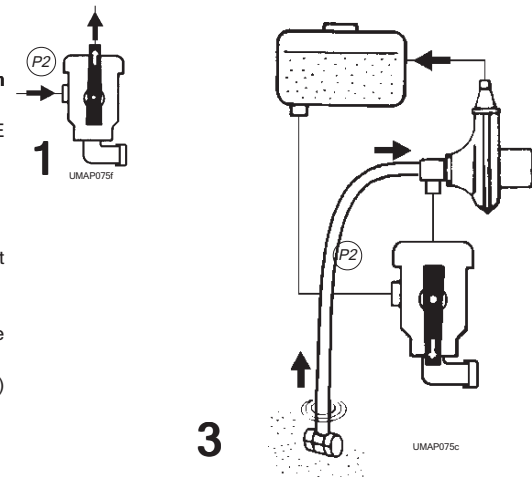

9. Start the tractor, respecting the safety norms, and lift the atomizer in working position.
10. Engage the PTO and keep it at 500 rpm.
11. Start the water recycle in the tank, move the P2 three way cock lever the position 3.
The tank filling begins through the return piping (T3)

3