

# cima<sup>®</sup>

ATOMIZZATORI-IMPOLVERATORI



cima<sup>®</sup>



## New Plus

Loc. Molino Quaroni n.7, Montù Beccaria - PV - (ITALY)  
Tel. +39.0385.246636 - [www.cima.it](http://www.cima.it)

### Operation and maintenance instructions

Dear Customer, thank you very much!  
We want to congratulate with you, for having chosen a **cima** sprayer.

Your choice shows the wisdom of the well-informed Purchaser, aware of the fact, that the required features of quality, technique and reliability must be satisfied at the right price!

Our continuous engagement in R&D and in testing our machines allows us to realize products able to offer the best performances, a high reliability and a great easiness of use at the same time !

Our first goal, is to get our Customers happy for having met us!

The "Spare parts catalogue" of this sprayer/sprayhead is available in the "restricted area" on website [www.cima.it](http://www.cima.it).

In order to accede, use:

User name: **sprayer**  
Password: **844719KE**



Warranty conditions

1. Warranty

The goods sold are covered by a general warranty that ensures the good quality of the materials, solid construction and regular operation for twelve months from the date of delivery. During the warranty period, C.I.M.A. S.p.A. pledges to replace, free of charge, the parts which, in his unquestionable judgement, are considered defective, provided that the flaws and defects cannot be attributed to poor use or maintenance of the product or an unreasonable, inappropriate and unsuitable use of such product with respect to the technical instructions supplied by C.I.M.A. S.p.A. The products which have been modified, repaired, assembled or tampered with by a third party, consumption materials and the parts subject to wear and tear are excluded from the warranty. The replacements will be made free CIMA S.p.A. works and the buyer will be responsible for all shipping and return expenses. The buyer will be responsible for the costs of the labour needed to replace the parts considered defective. The resolution of the contract and any compensation for damage cannot be claimed by the buyer except for serious faults to be proven by said buyer. The warranty will no longer be extended to the buyer if he does not respect the agreed upon payment procedures and terms.

2. Reporting defects in goods

The claims for flaws or defects in the goods shall be submitted within eight days from when such goods are received or from when hidden defects are discovered, in writing, by means of a registered letter. No claim can be made, nor as an exception, in a court of law if the goods, for which the claim is submitted, have not been regularly paid. Any claim concerning a single delivery of goods will not exonerate the buyer from his obligation to pick-up the remaining quantity of goods within the limit of the order.

3. To pass safety information

The buyer is responsible towards the final user for the safety information shown on the sale documentation, concerning use limit, performances and product features.

4. Validity and acceptance

The guarantee is valid if the CERTIFICATE OF GUARANTEE is sent, to C.I.M.A. S.p.A., with every part of it filled in, within 30 days from the date of purchase (referring to the date of the postmark).

Informative according to the D. L. n. 196 of the 2003 ("Code in matter of protection of the personal data")

Dear customer, according to art. 13 of the D.Lgs. 196/03 "Unique Text on Privacy" (referred to as 'Law' here below) we would like to inform you about the following:

- 1) the personal data given to C.I.M.A. S.p.A. when filling in the "Warranty Certificate" will be processed respecting the above mentioned regulations and the rules of privacy stated there in;
2) according to art.4, paragraph 1, lett. a) of the Law, the handling of personal data signifies "whatever operation or set of operations carried out (even without the aid of electronic instruments) regarding the collection, recording, organization, conservation, research, handling, modification, selection, extracting of details, comparison of, use of, connecting to, blockage, passing on, distributing, cancellation and destruction of data, even if not recorded in a data bank";
The handling of the personal data given is carried out by automatized and non automatized instruments, with controlled access and as specified by clause B of the Law;
3) the data are processed to an institutional end, in connection with or useful to the activities of C.I.M.A. S.p.A. for filing, processing and management;
4) the data are collected and recorded so that access is only allowed to authorized persons and they may be processed exclusively by C.I.M.A. S.p.A. to the above mentioned end;
5) the collected data may only be given to a third party exclusively in connection with accounting imposed by fiscal law and in the case of demands from the judicial authority.

In addition we inform you that any interested party may exercise his rights mentioned in art.7 of the Law; in the exercise of such rights the interested party may delegate or give a proxy, in writing, to persons or associations. The authority to carry out this processing is C.I.M.A. S.p.A., represented in person by a lawyer. The data processing is done by instruments fit to guarantee the safety and privacy as specified in clause B of the Law.

Mounted sprayer
New Plus

Model: .....

Serial Number: .....

(Pubblication N° LUM-NPLUS-00-EN)

OPERATION AND
MAINTENANCE INSTRUCTIONS

© CIMA S.P.A. 2001 - 2018 Private property.

Any reproduction, even if partial, is forbidden if not preventively authorized in writing by the Cima S.p.A. company.



**WARRANTY CERTIFICATE**

This warranty is valid only when this registration form is completed and returned, within thirty (30) days from the date of purchase, to the following address:  
C.I.M.A. S.p.A. - Loc.Molino Quaroni - 27040 Montù Beccaria - (PV) - Italy  
or sent by fax to the number +39.0385.246637 or by email to: info@cima.it

Owner's Name:.....

Company Name:.....

Address: .....

City: ..... State: ..... Postcode: .....

Email: ..... Tel. No:.....

Date of Purchase:..... Invoice No:.....

Machine Model: ..... Serial No:.....

Sprayhead Model: .....

Authorized Dealer's Stamp (compulsory)

**PRIVACY**

**Consent to the use of personal data**

"In compliance with the Italian legislative Decree no. 196 dated 30/06/2003, I hereby authorize C.I.M.A. S.p.A. to use and process my personal details contained in this document."

Date..... Signature.....

cut along the dotted line

**Warranty conditions**

**1. Warranty**

The goods sold are covered by a general warranty that ensures the good quality of the materials, solid construction and regular operation for twelve months from the date of delivery.

During the warranty period, C.I.M.A. S.p.A. pledges to replace, free of charge, the parts which, in his unquestionable judgement, are considered defective, provided that the flaws and defects cannot be attributed to poor use or maintenance of the product or an unreasonable, inappropriate and unsuitable use of such product with respect to the technical instructions supplied by C.I.M.A. S.p.A. The products which have been modified, repaired, assembled or tampered with by a third party, consumption materials and the parts subject to wear and tear are excluded from the warranty. The replacements will be made free C.I.M.A.S.p.A. works and the buyer will be responsible for all shipping and return expenses. The buyer will be responsible for the costs of the labour needed to replace the parts considered defective. The resolution of the contract and any compensation for damage cannot be claimed by the buyer except for serious faults to be proven by said buyer. The warranty will no longer be extended to the buyer if he does not respect the agreed upon payment procedures and terms.

**2. Reporting defects in goods**

The claims for flaws or defects in the goods shall be submitted within eight days from when such goods are received or from when hidden defects are discovered, in writing, by means of a registered letter.

No claim can be made, nor as an exception, in a court of law if the goods, for which the claim is submitted, have not been regularly paid.

Any claim concerning a single delivery of goods will not exonerate the buyer from his obligation to pick-up the remaining quantity of goods within the limit of the order.

**3. To pass safety information**

The buyer is responsible towards the final user for the safety information shown on the sale documentation, concerning use limit, performances and product features.

**4. Validity and acceptance**

The guarantee is valid if the CERTIFICATE OF GUARANTEE is sent, to C.I.M.A. S.p.A., with every part of it filled in, within 30 days from the date of purchase (referring to the date of the postmark).

**Informative according to the D. L. n. 196 of the 2003 (“Code in matter of protection of the personal data”)**

Dear customer, according to art. 13 of the D.Lgs. 196/03 “Unique Text on Privacy” (referred to as ‘Law’ here below) we would like to inform you about the following:

- 1) the personal data given to C.I.M.A. S.p.A. when filling in the “Warranty Certificate” will be processed respecting the above mentioned regulations and the rules of privacy stated there in;
- 2) according to art.4, paragraph 1, lett. a) of the Law, the handling of personal data signifies “whatever operation or set of operations carried out (even without the aid of electronic instruments) regarding the collection, recording, organization, conservation, research, handling, modification, selection, extracting of details, comparison of, use of, connecting to, blockage, passing on, distributing, cancellation and destruction of data, even if not recorded in a data bank”;
- The handling of the personal data given is carried out by automatized and non automatized instruments, with controlled access and as specified by clause B of the Law;
- 3) the data are processed to an institutional end, in connection with or useful to the activities of C.I.M.A. S.p.A. for filing, processing and management;
- 4) the data are collected and recorded so that access is only allowed to authorized persons and they may be processed exclusively by C.I.M.A. S.p.A. to the above mentioned end;
- 5) the collected data may only be given to a third party exclusively in connection with accounting imposed by fiscal law and in the case of demands from the judicial authority.

In addition we inform you that any interested party may exercise his rights mentioned in art.7 of the Law; in the exercise of such rights the interested party may delegate or give a proxy, in writing, to persons or associations. The authority to carry out this processing is C.I.M.A. S.p.A., represented in person by a lawyer.

The data processing is done by instruments fit to guarantee the safety and privacy as specified in clause B of the Law.

**LISTING OF VALID PAGES**

This publication consists of 85 pages, subdivided as follows:

N° OF PAGE	REVISION	BASE
from I to VI	00	January 2013
from 1 to 79	00	January 2013

**ADDITIONAL RECORDS AND VARIANTS**

REVISION	DESCRIPTION
00	First Edition, January 2013
01	
02	
03	
04	
05	
06	
07	
08	
09	

**GENERAL INDEX**

1 FOREWORD ..... 1

1.1 CHECKS TO BE CARRIED OUT AT MATERIAL RECEPTION ..... 1

1.2 PUBLICATION IDENTIFICATION ..... 1

1.3 ATTACHED PUBLICATIONS ..... 1

1.4 PURPOSE OF PUBLICATION ..... 1

1.5 REFERENCE TO REGULATIONS ..... 2

1.6 USING THE MANUAL ..... 2

1.7 UPDATES ..... 2

2 GLOSSARY ..... 3

2.1 TERMINOLOGY ..... 3

2.2 ABBREVIATIONS ..... 3

2.3 DECALS ..... 3

3 GENERAL INFORMATION ..... 7

3.1 MACHINE IDENTIFICATION ..... 7

3.2 TECHNICAL ASSISTANCE ..... 7

3.3 SAFETY NOTICES ..... 7

3.3.1 General ..... 7

3.3.2 Precautions against the fires ..... 8

3.4 SAFETY SYSTEMS ..... 9

3.5 HANDLING OF AGRO-CHEMICALS ..... 9

3.5.1 Storage ..... 10

3.5.2 Specific equipment ..... 10

3.5.3 Disposal of empty containers and agro-chemicals residues ..... 10

3.5.4 Personal Protective Equipment (PPE) ..... 11

4 MACHINE'S STRUCTURAL ANALYSIS ..... 12

4.1 FRAME ..... 13

4.2 FAN SERVO AMPLIFIER ..... 14

4.3 HYDRAULIC CIRCUIT ..... 15

4.3.1 Operating principle ..... 15

4.3.2 Hydraulic circuit components ..... 19

4.4 TECHNICAL DATA ..... 28

4.4.1 SPRAYERS DIMENSIONS AND WEIGHTS ..... 28

4.4.2 Weight of accessories ..... 29

4.4.3 Centrifugal pump CD32 ..... 31

4.4.4 Filters ..... 31

**WARRANTY CERTIFICATE**

Copy for the owner (to be kept in the manual "Operation an maintenance instructions").

Owner's Name: .....

Company Name: .....

Address: .....

City: ..... State: ..... Postcode: .....

Email: ..... Tel. No: .....

Date of Purchase: ..... Invoice No: .....

Machine Model: ..... Serial No: .....

Sprayhead Model: .....

Authorized Dealer's Stamp (compulsory)

**PRIVACY**

**Consent to the use of personal data**

"In compliance with the Italian legislative Decree no. 196 dated 30/06/2003, I hereby authorize C.I.M.A. S.p.A. to use and process my personal details contained in this document."

Date ..... Signature .....

**Appunti**

4.4.5 Tanks..... 31

4.4.6 Fans ..... 31

5 COUPLING MODALITIES ..... 32

5.1 HITCHING TO THE TRACTOR ..... 32

5.2 MOUNTING OF THE TRANSMISSION SHAFT..... 33

5.3 INSTALLATION OF REMOTE CONTROLS ..... 34

5.3.1 Electrical control panel - E10 ..... 34

5.3.2 Manual 2-tap distributor - P9..... 35

5.3.3 E.P.A. Control Unit ..... 35

6 DISTRIBUTION DEVICES ..... 36

6.1 POSITIONING OF FAN CASING ..... 37

7 ACCESSORIES ..... 38

7.1 FILLING PIPE ..... 38

7.2 PAIR OF WHEELS ..... 38

7.3 SWIVELLING DEVICE..... 39

7.4 E.P.A. KIT - DELIVERY PROPORTIONAL ADVANCEMENT ..... 40

8 FILLING ..... 41

8.1 FOREWORD - USE OF THE FAN DISENGAGEMENT ..... 41

8.1.a Disengagement of the fan ..... 41

8.1.b Fan engagement to perform the treatment ..... 42

8.2 FILLING THROUGH POURING FROM THE TO ..... 42

8.3 FILLING WITH THE SPECIFIC PIPE (OPTIONAL DEVICE) ..... 43

9 AGITATION ..... 46

10 OPERATING PROCEDURES ..... 46

10.1 PRELIMINARY OPERATIONS TO TREATMENT ..... 46

10.2 - PREPARATORY OPERATIONS TO TREATMENT ..... 47

10.3 THE TREATMENT..... 48

10.4 PROCEDURE TO WASH THE HYDRAULIC CIRCUIT ..... 49

10.5 END OF TREATMENT - STORAGE..... 51

10.5.1 Daily ..... 51

10.5.2 End of seasonal cycle ..... 53

11 TANK AND HYDRAULIC CIRCUIT DRAINING..... 54

12 LIFTING AND TRANSPORT..... 55





Dotted lines for notes.

1.1 CHECKS TO BE CARRIED OUT AT MATERIAL RECEPTION

At reception of the machine, make sure that this one is complete and in good condition in every part. If any damaged parts are found out, timely inform about that the machine Distributor, or directly contact C.I.M.A. SpA.

- Upon receipt of the machine, expressly verify the following conditions:
- that the machine is delivered assembled in all its parts, and that the equipment fully complies with the requested configuration (that procedure is necessary, because for overall dimensions' requirements the machine is often partially disassembled during the transport);
- that the connections are correctly mounted;
- that the cable clamps are correctly tightened, as well as all the fittings and connections;
- that all the protections are both present and firmly fastened;
- that the oil level inside the fan support is correct;
- that the fan, the fan protection casing or other parts of the machine ARE NOT damaged because of any bumps suffered during the transport.

1.2 PUBLICATION IDENTIFICATION

The "OPERATION AND MAINTENANCE INSTRUCTIONS" manual is an integrative part of the sprayers. It is identified by a Publication No. located on the frontispiece, and through which the document can be identified, traced and/or subsequently referred to. The information elements contained herein are updated as at the date of publication. C.I.M.A. S.p.A. reserves the right to modify its machines without notice, with the purpose of applying technical enhancements, and it declines all responsibility for possible omissions from the publication. All rights are reserved. No parts of this book may be reproduced or utilized in any form or by any means, electronic or mechanical, including photocopying, recording, or by any information storage and retrieval system, without permission in writing by C.I.M.A. S.p.A..

1.3 ATTACHED PUBLICATIONS

- Spare parts catalogue, available in the "restricted area" on website www.cima.it (see on the inside cover);
- Distribution devices, "Operation and maintenance instructions";
- Distribution devices, "Spare parts catalogue";
- "Low Volume - Instructions for sprayer adjustment".

1.4 PURPOSE OF PUBLICATION

All indications contained in this manual are aimed at the user of the sprayer. The duration of the machine and its operation, the operator's safety and the respect for the environment are dependent upon scrupulous observance of the stated norms. Before making use of the sprayer, the user must read, understand and abide by all regulations listed in this manual.

## 1.5 REFERENCE TO REGULATIONS

This manual was set out conforming to the regulations contained in following documents:

- Directive 2006/42/CE: Attachment 1 point 1.7.4;
- UNI 10653: Technical Documentation;
- UNI 10893: Technical Documentation.

## 1.6 USING THE MANUAL

Read every part of this manual, paying attention to the WARNING and DANGER indications both on the text and on the machine or on components.

All operations suggested by the manual will have to be followed with the utmost care and only after having understood the negative consequences of improper usage.

The following “symbols” are used within the text in order to highlight and visually identify the importance of the various types of information:



Indicates important additional information.



Non observance can result in permanent damage to the sprayer.



Highlights possibly dangerous situations to people.

The manual, with relevant attachments and possible integrating issues, must be kept with the utmost care and must always be complete, integer and legible in every part. Should it be mislaid it is imperative to immediately request a duplicate from C.I.M.A. S.p.A.

Should the decals originally applied on the machine be mislaid, damaged or become incomprehensible, they should be promptly replaced.

For every type of distribution device (Head) delivered with the sprayer, a specific user and maintenance manual is attached. All the head manuals must always accompany the one of the machine.



- The manual must always be kept for the sprayer's whole operational life.
- Any modification received must be permanently inserted in this publication.
- The manual must be ceded with the sprayer should this be sold.

## 1.7 UPDATES

Any amendments or additions that C.I.M.A. S.p.A. may send the sprayer's owner will be accompanied by the necessary instructions to be included with this publication, becoming an integral part of it.



**THE OWNER AND/OR THE OPERATOR OF THE SPRAYER ARE NOT PERMITTED TO MODIFY THE STRUCTURE OR THE SPECIFIC OPERATION OF THE SPRAYER ITSELF. ANY REPAIRING INTERVENTION HAS TO BE CARRIED OUT EITHER AT THE DEALERS' OR AT THE C.I.M.A. S.p.A. AUTHORIZED WORKSHOPS, OTHERWISE ANY KIND OF WARRANTY IMMEDIATELY CEASES AND C.I.M.A. S.p.A. IS CLEARED OF ANY CONSEQUENT AND/OR IMPLIED RESPONSIBILITY.**

## 19.1 General information

The goods sold are covered by a general warranty that ensures the good quality of the materials, solid construction and regular operation for twelve months from the date of delivery.

During the warranty period, C.I.M.A. S.p.A. pledges to replace, free of charge, the parts which, in his unquestionable judgement, are considered defective, provided that the flaws and defects cannot be attributed to poor use or maintenance of the product or an unreasonable, inappropriate and unsuitable use of such product with respect to the technical instructions supplied by C.I.M.A. S.p.A.

The products which have been modified, repaired, assembled or tampered with by a third party, consumption materials and the parts subject to wear and tear are excluded from the warranty.

The replacements will be made free CIMA S.p.A. works and the buyer will be responsible for all shipping and return expenses.

The buyer will be responsible for the costs of the labour needed to replace the parts considered defective. The resolution of the contract and any compensation for damage cannot be claimed by the buyer except for serious faults to be proven by said buyer.

The warranty will no longer be extended to the buyer if he does not respect the agreed upon payment procedures and terms.

## 19.2 Reporting defects in goods

The claims for flaws or defects in the goods shall be submitted within eight days from when such goods are received or from when hidden defects are discovered, in writing, by means of a registered letter.

No claim can be made, nor as an exception, in a court of law if the goods, for which the claim is submitted, have not been regularly paid.

Any claim concerning a single delivery of goods will not exonerate the buyer from his obligation to pick-up the remaining quantity of goods within the limit of the order.

## 19.3 To pass safety information

The buyer is responsible towards the final user for the safety information shown on the sale documentation, concerning use limit, performances and product features.

## 19.4 Validity and acceptance

The warranty is valid if the CERTIFICATE OF WARRANTY is sent, to C.I.M.A. S.p.A., with every part of it filled in, within 30 days from the date of purchase (referring to the date of the postmark).



### DICHIARAZIONE DI CONFORMITÀ

ai sensi della Direttiva 2006/42/CE come emendata dalla Direttiva 2009/127/CE e successive modificazioni

<b>DECLARATION OF CONFORMITY</b> as Directive 2006/42/EC as amended by the Directive 2009/127/EC and subsequent modifications	<b>DECLARATION DE CONFORMITE</b> selon la Directive 2006/42/CE comme modifiée par la Directive 2009/127/CE et modifications ultérieures
<b>ÜBEREINSTIMMUNGS-ERKLÄRUNG</b> II. Direktiven 2006/42/CE wie abändert von den Direktiven 2009/127/CE und nachfolgenden Änderung	<b>DECLARATION DE CONFORMIDAD</b> con arreglo a la Directiva 2006/42/CE según la enmendada por la Directiva 2009/127/CE y modificaciones siguientes

**CIMA S.p.A. - 27040 Montù Beccaria - Loc. Molino Quaroni - (PV) - ITALIA**  
 http://www.cima.it - e-mail: info@cima.it - Tel. +39.0385.246633 - Fax +39.0385.246637

DICHIARA SOTTO LA PROPRIA RESPONSABILITÀ CHE LA MACCHINA	HERE WITH DECLARES UNDER THEIR PERSONAL RESPONSIBILITY, THE FOLLOWING MACHINE:	DÉCLARE SOUS NOTRE RESPONSABILITÉ QUE LA MACHINE DÉCRITE CI-DESSOUS	BEZÄHRT MIT UNTER INHERER PERSÖNLICHEN VERBAUFORTUNG DAS DIE MASCHINE	DECLARA BAJO DE LA PROPIA RESPONSABILIDAD QUE LA MAQUINA
--	--	---	---	--

SERIE, TIPO - MODEL, TYPE, SERIE, TYPE, MODEL, TYPE, SERIE, TYPE

MATICOLA - SERIAL NUMBER, MATRICOLA - SERIAL NUMBER

È conforme ai Requisiti essenziali di Sicurezza e di Tutela della Salute di cui alla Direttiva: 2006/42/CE - 17/05/2006 2009/127/CE - 21/10/2009 e successive modificazioni.	Conforms to the essential safety regulations as set out in the European Community Directives: 2006/42/CE - 17/05/2006 2009/127/CE - 21/10/2009 and subsequent modifications.	Est conforme aux exigences essentielles de Sécurité et de Santé de la Santé de la Directive: 2006/42/CE - 17/05/2006 2009/127/CE - 21/10/2009 et modifications ultérieures.	Übereinstimmt mit den wesentlichen Vorschriften der Sicherheitsvorschriften in der Gesundheitsvorsorge II. EWG Direktive Nr.: 2006/42/CE - 17/05/2006 2009/127/CE - 21/10/2009 und nachfolgenden Änderungen/Änderungen.	Cumple con los requisitos esenciales de Seguridad y de Preservación de la Salud contenidos en las Directivas: 2006/42/CE - 17/05/2006 2009/127/CE - 21/10/2009 y modificaciones siguientes.
---	---	--	--	--

Per la verifica della Conformità di cui alle direttive sopra menzionate, sono state consultate le seguenti Norme armonizzate:  
 EN 13857  
 EN 349  
 EN 4254-1 e EN 4254-4

Pour vérifier la conformité aux directives susmentionnées, ont été prises en compte les Normes harmonisées suivantes:  
 EN 13857  
 EN 349  
 EN 4254-1 e EN 4254-4

Für die Überprüfung dieser Übereinstimmungs-Erklärung ist, obigen Direktiven sind folgende Normen konsultiert worden:  
 EN 13857  
 EN 349  
 EN 4254-1 e EN 4254-4

Para comprobar la conformidad a la que se refieren las Directivas anteriormente citadas, se han consultado las siguientes Normas Armonizadas:  
 EN 13857  
 EN 349  
 EN 4254-1 e EN 4254-4

Responsible del Fascicolo Tecnico - The Security and Technical File Official - Responsable Sécurité, Homologation et Dossier Technico - Technisch Dossier und Sicherheits-Beauftragter - Responsable de la Seguridad y del Fascículo Técnico

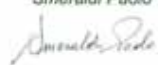
Smeraldi Paolo  

**cima** Atomizzatori e Impolveratori  
 CIMA S.p.A. - 27040 Montù Beccaria  
 Loc. Molino Quaroni - (PV) Italy

(\*) Prevista SOLO per il mercato interno Unione Europea (EU)

### 2.1 TERMINOLOGY

The terms FRONT, REAR, RIGHT and LEFT utilised in this publication refer to the sprayer as seen by an operator from behind the operative unit along the drive line and facing it: **the rear part** of the machine is that closest to the operator, and is where the distribution device (Head) is mounted - and **the front part** is the one that gets attached to the tractor.

### 2.2 ABBREVIATIONS

cm	.....	centimetres
g	.....	grams
h	.....	hour
ha	.....	hectare
ha/h	.....	hectare per hour
kg	.....	kilogram
kg/cm <sup>2</sup>	.....	kilograms per square centimeter (atmosphere)
km	.....	kilometre
km/h	.....	kilometres per hour
l	.....	litres
l/h	.....	litres per hour
l/min	.....	litres per minute
Lm	.....	width in metres
m	.....	metre
Mesh	.....	N° of meshes per linear inch
Micron	.....	1/1000 of millimetre
mm	.....	millimetres
PPE	.....	Personal Protective Equipment
PTO	.....	power take-off
RPM	.....	revs per minute
s	.....	seconds

### 2.3 DECALS

The safety and use/maintenance decals applied to the machine are described in the following paragraph.



Every decal is marked with its part number, in case it needs to be replaced.

The arrangement of the adhesives on the machine is shown in the following pictures.

Safety decals



95001

- STOP THE ENGINE AND REMOVE THE KEY FROM THE TRACTOR'S CONTROL PANEL BEFORE CARRYING OUT ALL MAINTENANCE OR REPAIR OPERATIONS
- CONSULT THE USER AND MAINTENANCE MANUAL BEFORE USING OR INTERVENING ON THE MACHINE



95098

- CONSULT THE USER AND MAINTENANCE MANUAL BEFORE USING THE MACHINE
- DANGER OF CONTAMINATION BY CONTACT OR POISONOUS PRODUCTS INHALATION
- IT IS FORBIDDEN TO GET INTO THE TANK!



95099

- DANGER OF SPRAYS: KEEP AT A SAFE DISTANCE
- DANGER, PARTS IN MOTION. BEFORE REMOVING PROTECTION GUARDS, STOP THE TRACTOR, REMOVE THE KEY FROM THE TRACTOR'S CONTROL PANEL AND ENSURE THAT ALL MOVING PARTS HAVE STOPPED.



95012

- DANGER: MOUNT THE WHEELS AFTER HAVING HITCHED THE MACHINE TO THE HOISTER AND DISMANTLE THEM BEFORE UNHITCHING THE MACHINE FROM THE HOISTER



95010

- OPERATING SPEED OF THE DRIVE OUTLET (PTO): 540 RPM



95015

- BEFORE UTILISING THE RELEASE DEVICE, STOP THE TRACTOR, REMOVE THE KEY FROM THE TRACTOR'S CONTROL PANEL AND ENSURE THAT THE FAN HAS STOPPED.



95009

- DANGER: GLOVES MUST BE USED TO EMPTY THE TANK.

Use and maintenance decals



95079

- CHECK THE OIL LEVEL EVERY 8 HOURS: FAN SHAFT BEARINGS.



95057

- HAND WASHING TANK TAP

Imprint next to the tap.



95115

- GREASE YEARLY: FAN TIGHTENER SUPPORT AND FREEWHEEL



95019

- FILL ONLY WITH CLEAN WATER

Hand washing tank filler,  
Rinsing tank filler.

17 NOISE LEVEL 17

Sprayer Model	Observed equivalent average level L <sub>qA</sub> - dB(A)
New Plus 42	89,0 ± 0,2
New Plus 45	92,4 ± 0,2
New Plus 50	99,4 ± 0,2
New Plus 55	95,4 ± 0,2
New Plus 55 Super	95,4 ± 0,2
New Plus 55 Extra	95,4 ± 0,2

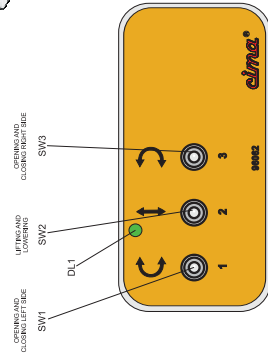
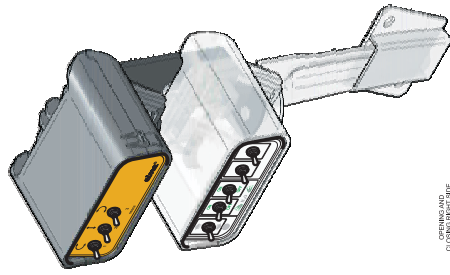

01670\_5

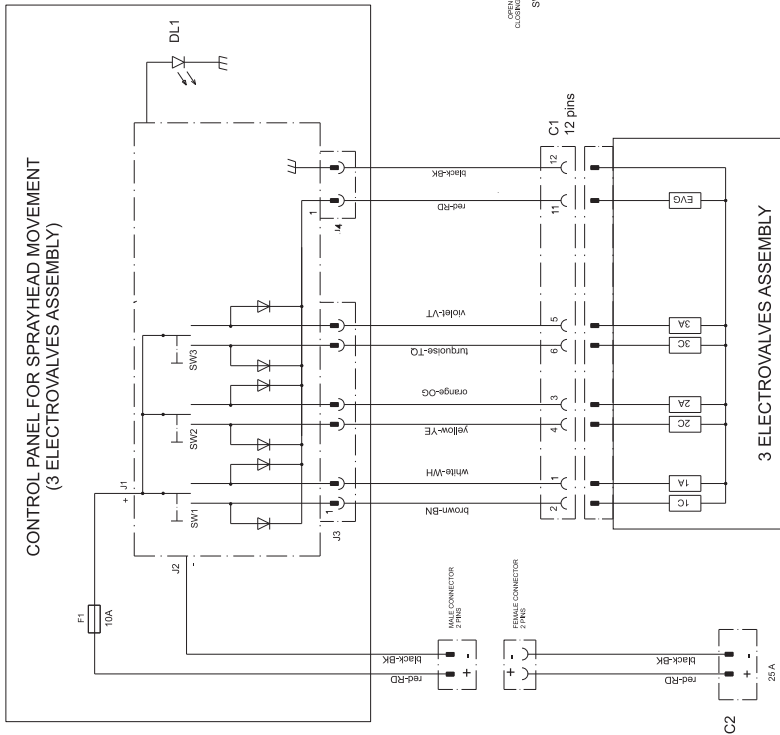

Wiring diagram - control panel for sprayhead movement (3 electrovalves assembly)

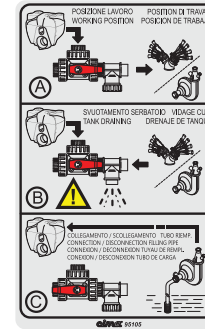

95105

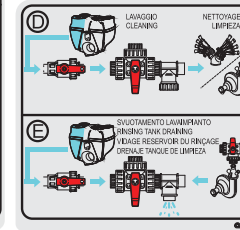

95104

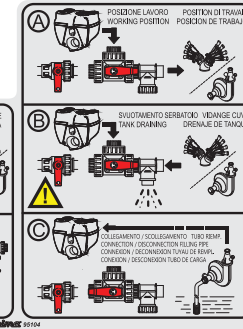

95059

- INDICATION ON THE OPERATION OF THE 3-WAY TAP (P2) (and P15 for the models where it is foreseen)

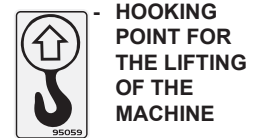

- INDICATION OF THE CHEMICAL EMPLOYED FOR THE TREATMENT

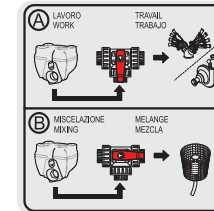

95058

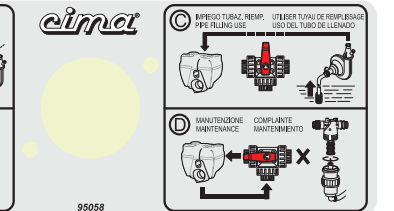

95058

- INDICATION ON THE OPERATION OF THE 3-WAY TAP (P6)

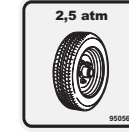

95066

- TIRES PRESSURE (for the models where it is foreseen)



95065

- WARNING: NEVER OPERATE THE SPRAYER WITHOUT LIQUID IN THE TANK

Positioning of the safety, use and maintenance decals

NOTE: The numbers with the asterisk (\*) indicate the adhesives relevant either to optional components or to accessories to be applied ONLY on the models and versions on which it is foreseen.

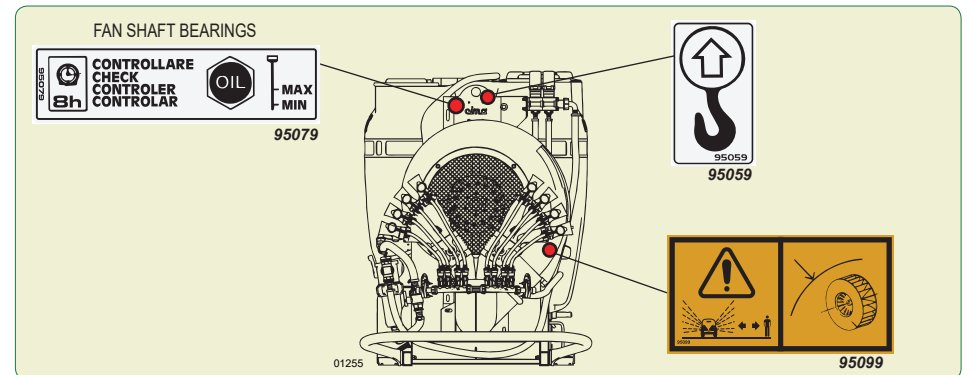

01255

95099

**95001**

**95065**

**95098**

**95115 (\*)**

**95009**

**95010**

**95057**

**95012**

**95014 (\*)**

**95015 (\*)**

**95056 (\*)**

**95105 (\*)**

(\*) For versions in which this is envisaged

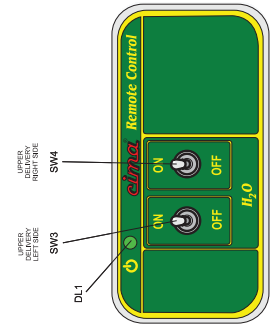
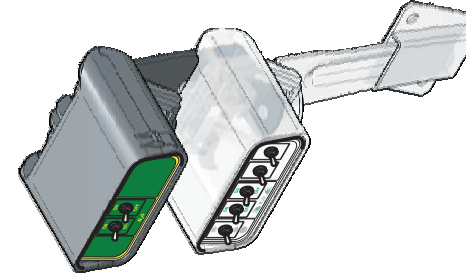

01670\_3

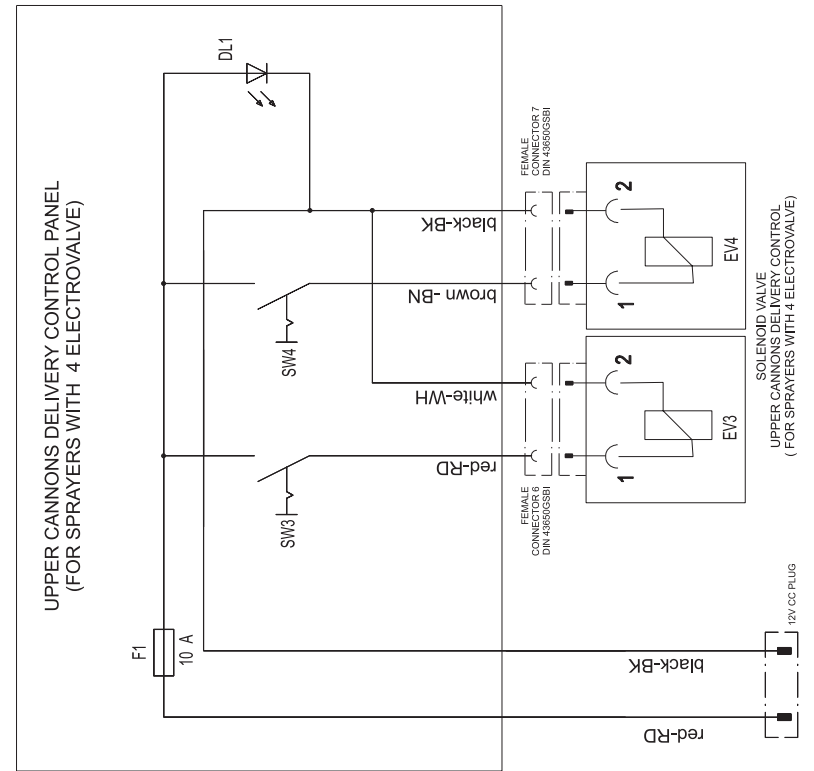

Wiring diagram - upper cannons delivery control panel

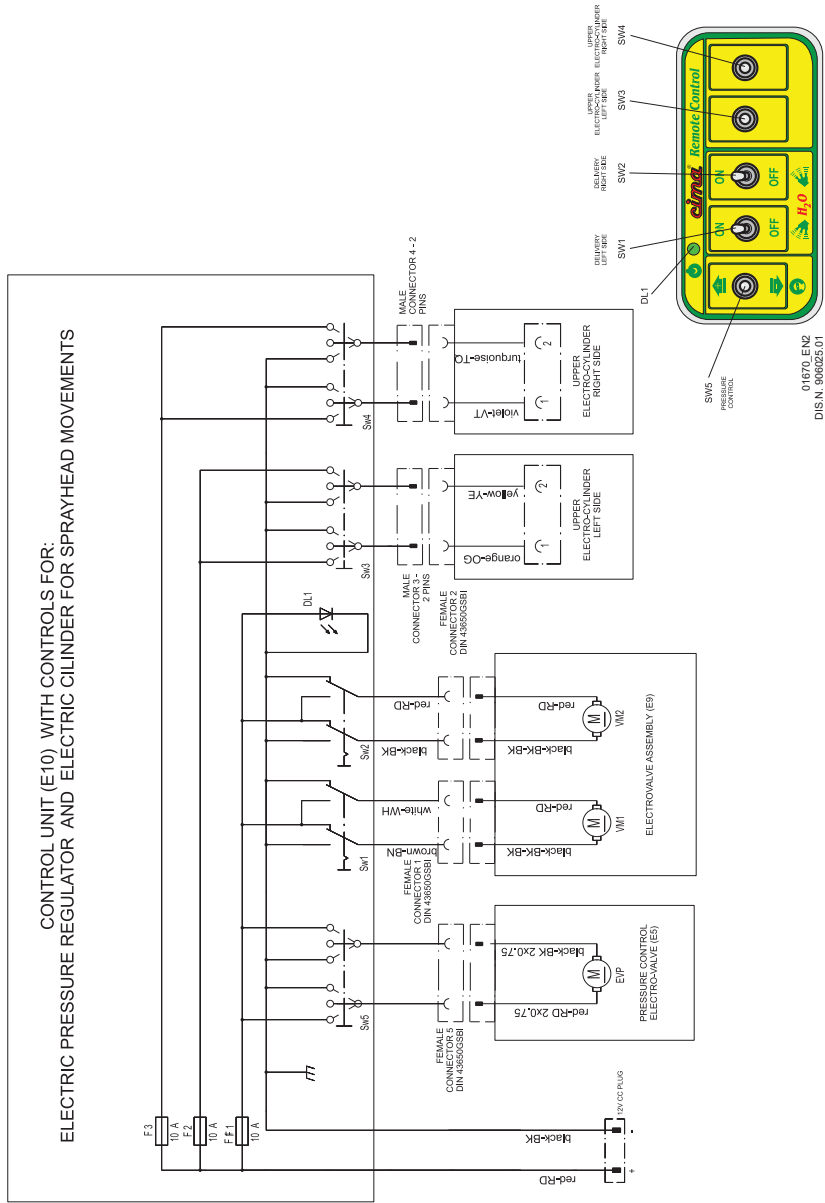

Wiring diagram - versions with electric pressure regulator and electric cylinder for sprayhead movements

3 GENERAL INFORMATION 3

3.1 MACHINE IDENTIFICATION

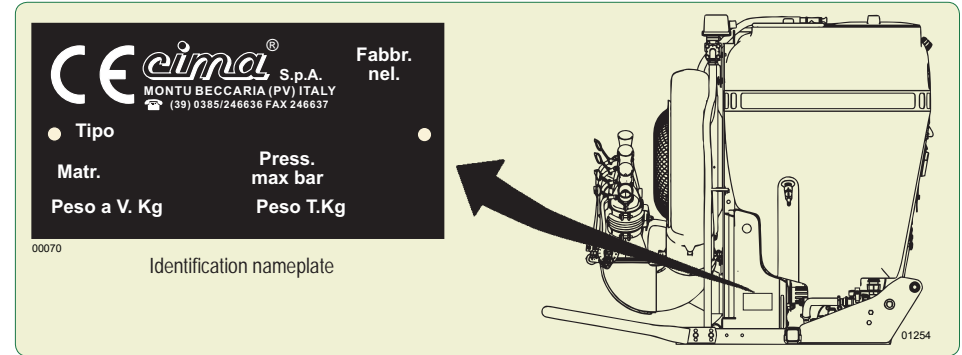

3.2 TECHNICAL ASSISTANCE

C.I.M.A. S.p.A. is at the complete disposal of customers for any type of intervention. The names and addresses of its service network, both in Italy and in foreign countries, can be requested from:

C.I.M.A. S.p.A. - 27040 Montù Beccaria - Loc. Molino Quaroni (PV) - ITALIA  
 tel. +39-0385-246636 - fax +39-0385-246637  
 e.mail service@cima.it  
 GPS: 45°03'19.3" N - 9°18'22.1" E

3.3 SAFETY NOTICES

3.3.1 General

The personnel appointed to the use of the machine must have acquired an exhaustive knowledge of the same one and of the dispositions contained inside this publication, be able to properly interpret the symbols of the adhesives applied on the machine, and, in addition, perfectly know the safety and the work hygienic rules in force in the country where the machine itself is to be used.

All the preparation, use, maintenance, moving and transporting operations must be carried out of the regulations contained in this publication.

**IT IS FORBIDDEN TO UTILISE THE SPRAYER FOR PURPOSES OTHER THAN FOR ITS INTENDED USE, SINCE IT WAS MANUFACTURED ONLY FOR SPRAYING AGRICULTURAL CROPS WITH ANTI-PARASITIC PRODUCTS. ANY USE OTHER THAN THOSE DESCRIBED IN THE USE PERMITTED IS CONSIDERED AS NOT CONFORMING AND THEREFORE IS NOT PERMITTED.**

It is necessary to scrupulously abide by the following general norms:  
 —check that the weight and power of the tractor are compatible with the sprayer to be used;  
 —verify that the tow capacity of the tractor is compatible with the total weight of the sprayer to be used;



On the identification plate, the full-load weight (PESO T.) of the machine is indicated, measured WITHOUT the distribution device, and WITHOUT the accessories possibly installed.

In order to calculate the weight on the hoister in operative conditions (at full load), add to the weight indicated on the identification plate (PESO T.), the weight of the distribution device which is used (see “Distribution devices – Use instructions” manual), the weight of the installed accessories (Par. 4.4.2) and the 50% of the weight of the used cardan shaft (see the relevant specific manual).

- before utilisation, check the correct tightening and securing of the machine’s various components, paying particular attention to the safety protections and to the moving parts;
  - only utilise protected cardan shafts provided with CE conformity certification.
- Carry out the assembly only if the drive outlets of both tractor and sprayer are equipped with the protection counter-guard;
- check that the cardan shaft is blocked by the appropriate anti-rotation chains;
  - keep people and animals away from the machine before starting it up;
  - don’t wear articles of clothing that might get caught in moving parts;
  - keep to a low speed while negotiating bumps or crossing ditches;
  - during the use of the machine, the operator must have a sufficiently good visibility on the working areas, consequently it is recommended to keep both clean and efficient the cab windows and the rear-view mirrors;
  - always stop the tractor’s engine and actuate the parking brake before carrying out any operation on the sprayer;
  - never leave the machine unguarded, when the key is inserted inside the tractor control panel;



- All maintenance and repair operations must be carried out only after having rinsed the tank and flushed the system.
- Before operating within the tank it is necessary to wash it thoroughly with clean water.
- The application of paints and/or solvents, the washing of closed environments and machinery as well as the utilisation of the air flow for purposes other than those expressly concerning the spraying of agro-chemicals is not permitted.
- It is forbidden to enter the tank.

### 3.3.2 Precautions against the fires

Don’t approach either flames or heat sources to the machines. The materials used for manufacturing the machine itself are made by widely using oil derivatives: tanks, pipes, wheels, plastic components; besides, the presence of lubricants and of chemical product residuals make them potentially flammable.



- It is forbidden to use the machine within a potentially explosive environment.
- It is forbidden to perform welding operations if ammonium salts were previously used.

## 16.2 WIRING DIAGRAM

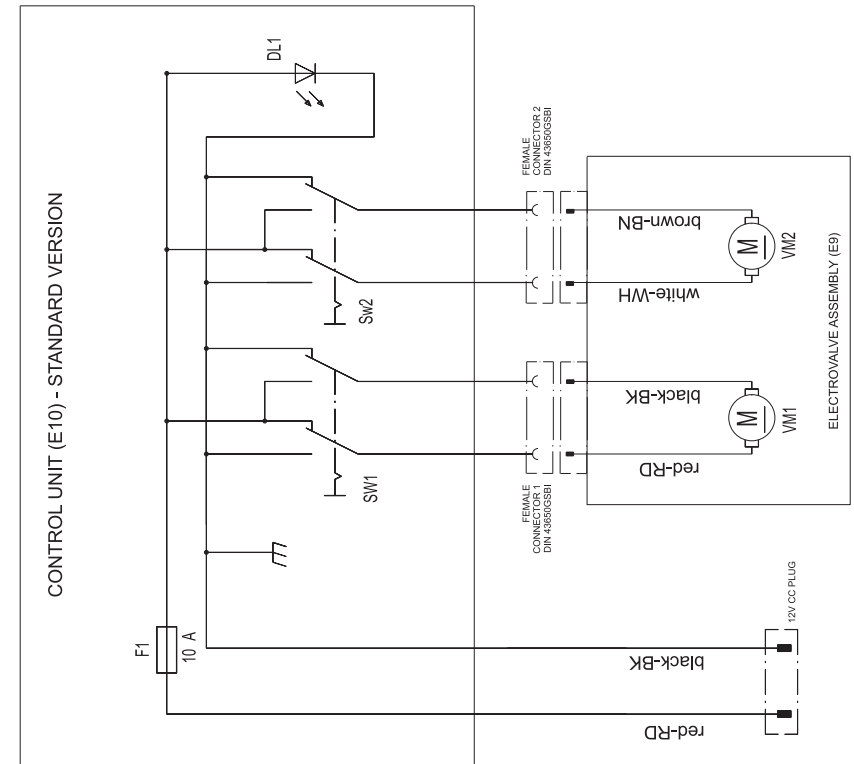
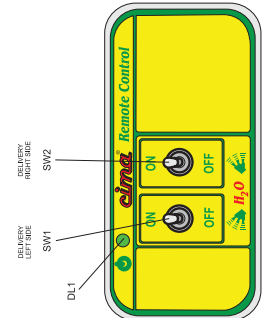

Wiring diagram - standard versions



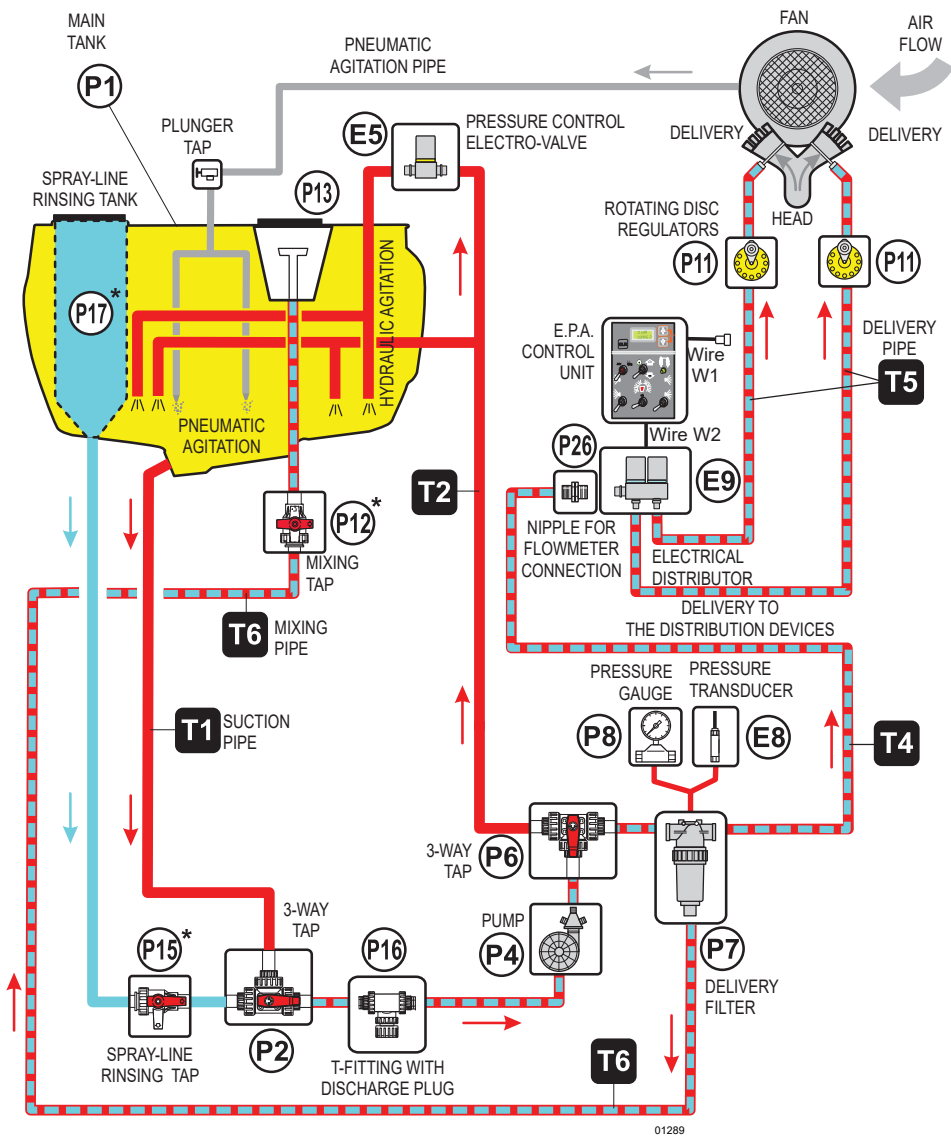

\* for versions on which it is foreseen

### 3.4 SAFETY SYSTEMS

All machine moving parts are suitably protected by guards and highlighted through the use of warning decals.



- It is forbidden to use the machine with these guards removed.
- Before removing the protection, stop the tractor's engine and remove the key from the control panel.

The pictures illustrate the machine's guarded parts::

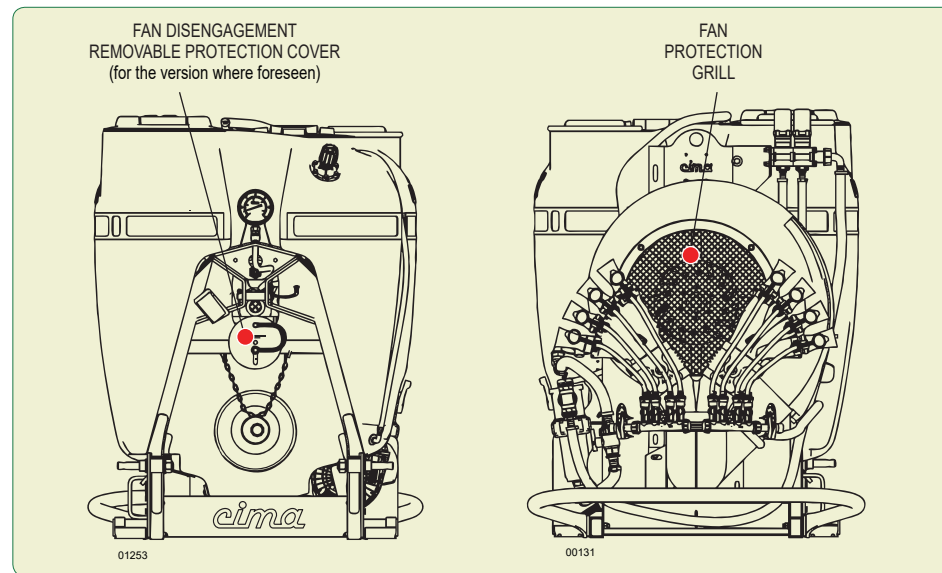

**THE OWNER AND/OR THE OPERATOR OF THE SPRAYER ARE NOT PERMITTED TO MODIFY THE STRUCTURE OR THE SPECIFIC OPERATION OF THE SPRAYER ITSELF. ANY REPAIRING INTERVENTION HAS TO BE CARRIED OUT EITHER AT THE DEALERS' OR AT THE C.I.M.A. S.p.A. AUTHORIZED WORKSHOPS, OTHERWISE ANY KIND OF WARRANTY IMMEDIATELY CEASES AND C.I.M.A. S.p.A. IS CLEARED OF ANY CONSEQUENT AND/OR IMPLIED RESPONSIBILITY.**

### 3.5 HANDLING OF AGRO-CHEMICALS

The operator could become contaminated due to accidental spray, contact or inhalation of products or crop-spraying mixtures.

The environment could become polluted by mixture over-spills, puncturing of containers, uncontrolled storage of used and unwashed containers or spillage into waterworks.

In order to avoid these risks the preparation and filling operations must be carried out in suitably appointed and adequately equipped sites.



To use pesticides (purchase, transport, loading, treatment planning, mixture preparation, field transfert, treatment performance, ending treatment liquid waste management, equipment rinsing and waste disposal) you must follow the country rules.



Absolutely respect the rules on the label of the product used referring to the dose for hectar and to the compatibility of other products.

### 3.5.1 Storage

**Fixed / stationary:** the site used must be well ventilated and secured by lockable doors in order to prevent even accidental access by children or unauthorised persons.

**Mobile:** the carrier equipment must be properly locked and kept under conditions whereby access by children or unauthorised persons can be prevented during the absence of the operator. All full or partially utilised containers must be secured against tipping, falling or breakage during transportation. Both types of storage must:

- have a suitable container for the storing of empty packaging materials should a specific storage area not be available;
- have a clean water supply readily available for washing, by means of a specific container or through connection to the waterworks system;
- have the use of fire extinguishers, should flammable products and substances be stored.



- All packages, whether whole or partially utilised, must be stored in their original packing and with the warning instructions clearly displayed and legible.
- The storage indications must always be scrupulously adhered to, as well as their utilisation and possible disposal as suggested on the product's original packaging.

### 3.5.2 Specific equipment

The site at which the preparation and filling out will take place must provide for:

- all the equipment necessary to the precise measuring of both the water quantity and the dose of product to be mixed in the tank at every filling;
- all the equipment and means useful to the preparation of the mixture and for the cleaning of the operator in case of contamination;
- all tools necessary to facilitate the direct introduction of the agro-chemicals in the tank;
- the allocation of clothing and specific equipment in order to avoid contamination by contact or inhalation during the whole operative phase of the intervention;
- the availability of proper equipment able to stop the uncontrolled spilling and flowing of the mixture;
- a retaining valve on the feed pipe when the filling of the tank takes place directly from the waterworks system.

### 3.5.3 Disposal of empty containers and agro-chemicals residues

Agro-chemicals are classified as “special” waste and their disposal must take place separately from “urban” wastes.



Empty packaging and contaminated containers to be done away with cannot be dispersed, burned or buried. The washing water for the cisterns and the tools utilised for the preparation of mixtures cannot be emptied on the ground, spilled into the sewage system or in waterways and rivers.

The disposal of special wastes is regulated by specific norms. In order to perform this operation it is necessary to obtain the relevant information from the Local Offices specifically appointed to rule on

## 16.1 HYDRO-PNEUMATIC DIAGRAM

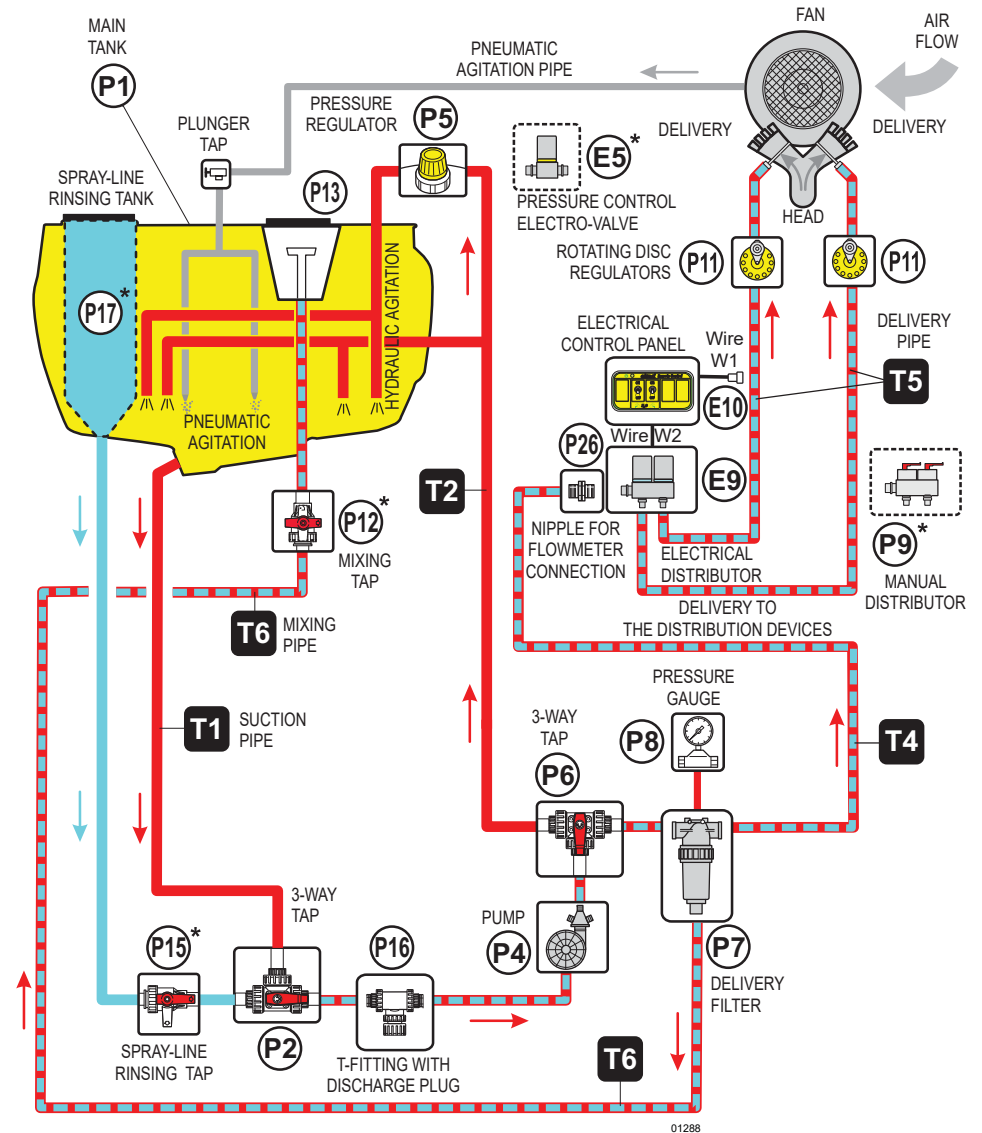

\*for versions on which it is foreseen

15.6.2 Check without flowmeter



**TESTING OF HYDRAULIC DELIVERY MUST BE MADE WITH THE SPRAYER ON A FLAT SURFACE. THE PROOF IS IN THE DETECTION OF TIME TO PROVIDE A KNOWN QUANTITY CONTENT OF LIQUID IN TANK**

1. Disengage the fan (for versions where it is foreseen): see Paragraph 8.1.a.
2. Close the taps of the 2-way distributor:
  - a. if manual (P9), the levers are to be lowered (horizontally positioned);
  - b. if electric, position to "OFF" the quick-break switches (E10).
3. Fill the tank with about 250 liters of clean water (**USED AS REFERENCE THE MARK OF LEVEL INDICATOR ON THE TANK** - see Paragraphs 8.2/8.3).
4. Engage the fan (for versions where it is foreseen): see Paragraph 8.1.b.



**The claimed performance is obtained with the PTO at 540 rpm. and with the fan running. For correct verification result this condition MUST ALWAYS BE RESPECTED.**

5. Bring the PTO to 540 rpm rotation rate.
6. Open the taps of the 2-way distributor:
  - a. if manual (P9), the levers are to be raised (vertically positioned);
  - b. if electric, position to "ON" the quick-break switches (E10).
7. Regulate the operating pressure, by acting on the pressure regulator (P5) (or electric E5) with the distributor, hand (P9) or electric (E9), open (DISTRIBUTION) and regulate the position of calibration disc (P11) in accord to "Delivery chart" relating to the sprayhead used.
8. Close the taps of the 2-way distributor:
  - a. if manual (P9), the levers are to be lowered (horizontally positioned);
  - b. if electric, position to "OFF" the quick-break switches (E10).
9. Add water to the tank until you reach the mark of 300 liters (reference).
10. Add additional 25 liters of water to the tank, the quantity required for the verification flow, using a graduated container or by weighing the amount payable (1 liter = 1 kg).
11. Open the taps of the 2-way distributor (manual or electric) to start delivery.
12. Continue the delivery until the water reaches the mark 300 liters on the level indicator.



**NOTED THE TIME ELAPSED BETWEEN THE RELEASE DELIVERY AND THE ACHIEVEMENT OF MARK 300 LITERS .**

13. Take the flow rate per hour:

Apply the formula: 
$$Q = \left( \frac{60}{t} \right) \times 25$$
 where: **Q**, is the hourly delivery detected (lt./h);  
**t**, is the time measured in minutes and seconds (centesimal).

this subject. The non compliance with these regulations can cause considerable damage to persons and animals as well as polluting the environment.

3.5.4 Personal Protective Equipment (PPE)

The use of phytosanitary products might imply a more or less high chemical risk for the workers on the basis of the toxicity and the dangerous properties of the phytosanitary product, of the level and duration of the exposure, of the absorption level through the respiratory tract, the skin, the mucosa and the ingestive tract, as well as the way and frequency of the use.

The "personal protective equipment" (PPE) are equipment that all the users of the machine need to wear and hold in order to be protected by one or more risks that are capable to treat the security or healthy during the job.

Regarding the basic requirements, PPE have to:

- be suitable to the risks that have to be prevented, without causing major risks themselves;
- be suitable to the existing conditions on the workplace;
- consider the ergonomic (easily adaptable, easy to wear and safe) or health needs for any users;
- be adaptable to the user according to his/her needs.

The PPE for the protection against dangerous chemical agents used for the operations that concern the exposition to phytosanitary products , pertains to the third class (3<sup>rd</sup> class – 0000).



**Use solely PPE equipped with the needed CE mark, in the scrupulous respect of the regulations in force in the country where the machine is in use and adequate to the phytosanitary product used.**

It's needed to use the PPE in each of the following working stage:

- tank filling and addition of the phytosanitary product;
- spraying,
- calibration of the sprayer,
- draining and cleaning of the tank,
- phytosanitary product replacement,
- servicing.

**The following must be worn:**

- for the protection of the body (gloves, suits, boots),
- for the protection of the respiratory tract, of the head and of the eyes (helmet, masks, filters, glasses, hoods and headdresses).



**Filters must be replaced following the producers' instructions, and in any case:**

- in case a bad smell is noticed;
- in case a resistance to the respiratory function is noticed;
- at least once a year in case of occasional use.

**For ALL PPE in use, follow the use instruction declared by the PPE producerse.**

The pictures indicate the position of the main components of the sprayer.

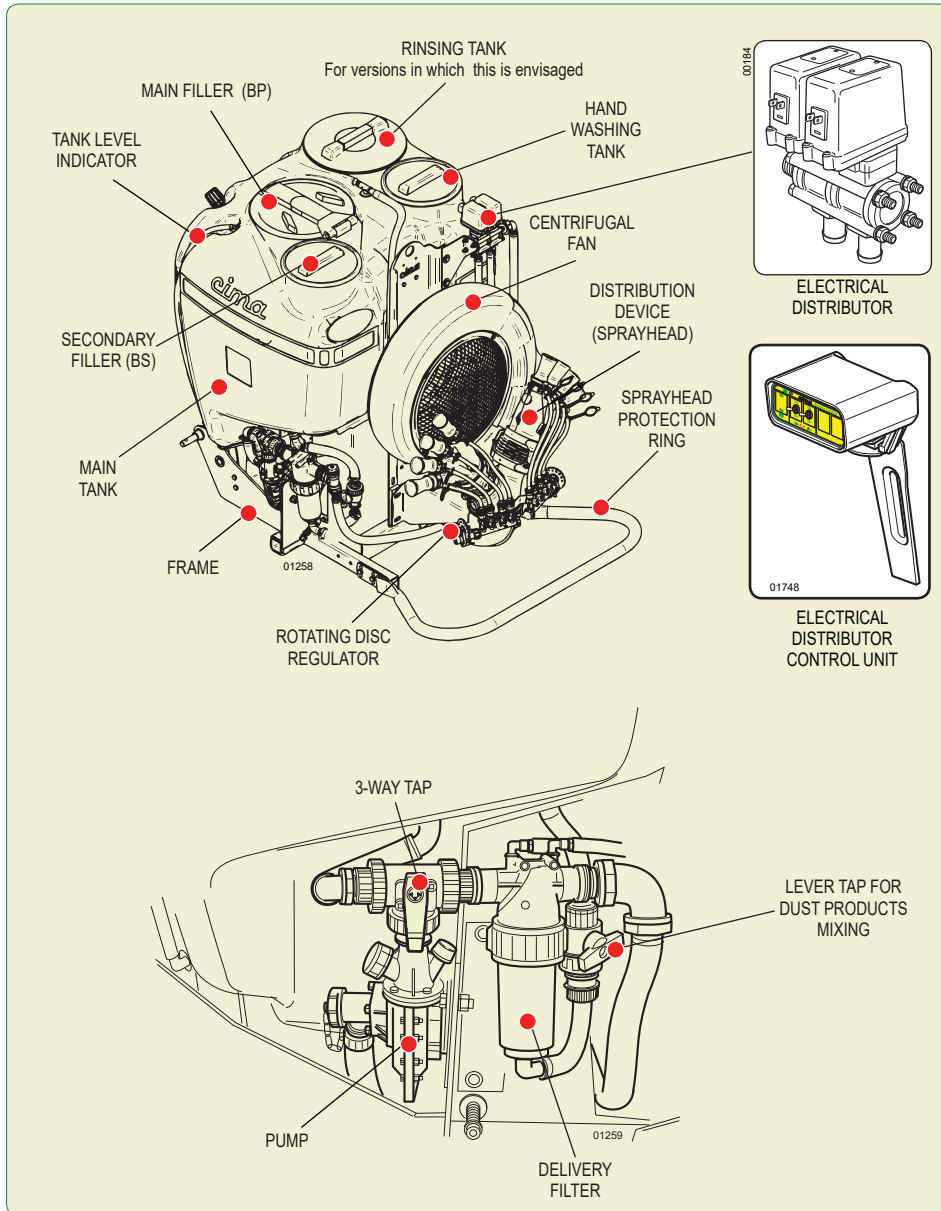

## 15.6 CHECK HYDRAULIC DELIVERY

**THE CHECK IS CONSIDERED TO BE SUCCESSFUL (THE MACHINE IS PROPERLY CALIBRATED) WHEN THE CALCULATED VALUE "Q" CORRESPONDS TO THE VALUE INDICATED ON THE "FLOW CHART" TABLE WITH A  $\pm 2.5\%$  TOLERANCE.**

If the resulting values are different, check the efficiency of the pipes, the fittings, the pressure gauge and the correct positioning of the calibration discs (P11). If necessary, replace the damaged or defective parts and repeat the test.

### 15.6.1 Check whit flowmeter

1. Disengage the fan (for versions where it is foreseen): see Paragraph 8.1.a.
2. Fill the tank with enough clean water to make the test.
3. Turn the 3-way valve (P6) to "D" position (Maintenance).
4. Disconnect the pipe (T4) from the electrical distributor (E9) or from manual distributor (P9).
5. Connect the appropriate flowmeter for the measurements to be made, between the pipe (T4) and the electrical distributor (E9) or the manual distributor (P9). If necessary, remove the fitting (P26) and use the fittings suitable for connecting the flowmeter.

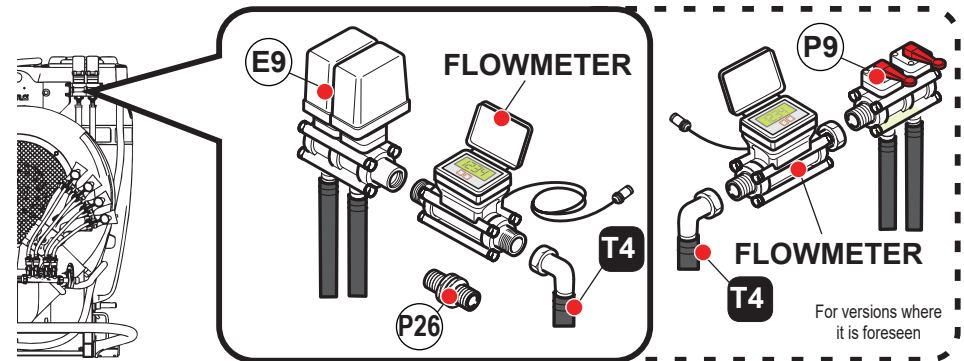

6. Turn the 3-way valve (P6) to "A" position (work)(Work - phytosanitary products distribution).
7. Engage the fan (for versions where it is foreseen): see Paragraph 8.1.b..



**The declared performance is achieved with the PtO at 540 rpm and with the fan running. For a correct result of the check, this condition MUST ALWAYS BE RESPECTED.**

8. Run the PtO at 540 rpm.
9. Open the taps of the 2-way distributor:
  - a. if electric (E10), set the switches to "ON"
  - b. if manual (P9) turn the levers vertically
10. Adjust the working pressure by using the manual pressure regulator (P5) (or the electric one E5) and the position of the calibration disc (P11) according to indications given on the "flow charts" for the distribution device (sprayhead) used.
11. Take the flow rate per hour.

### 15.5 LEVEL GAUGE CLEANING

1. With a suitable pliers release the clamp (1 and 4) fixing transparent tube of the level gauge.
2. Take off and remove the transparent tube (3).
3. Remove the red plastic ball (2).
4. Clean, with clean water, the transparent tube both in and outside.



Gather the rinsing water in a proper container provided to be waste according to the rules or used again, putting it in the tank, for a next treatment if suitable with the product to be used.

5. If the cleaning is not satisfactory, replace the transparent tube (3).



Waste the transparent tube according to the same method as per the pesticides container.

6. Put the red plastic ball (2) into the transparent tube (3).
7. Install the transparent tube (3) making slip it on the rubber fittings.
8. Place the clamps (1 and 4) fixing the transparent tube (3) of the level gauge and close them with a suitable pliers.

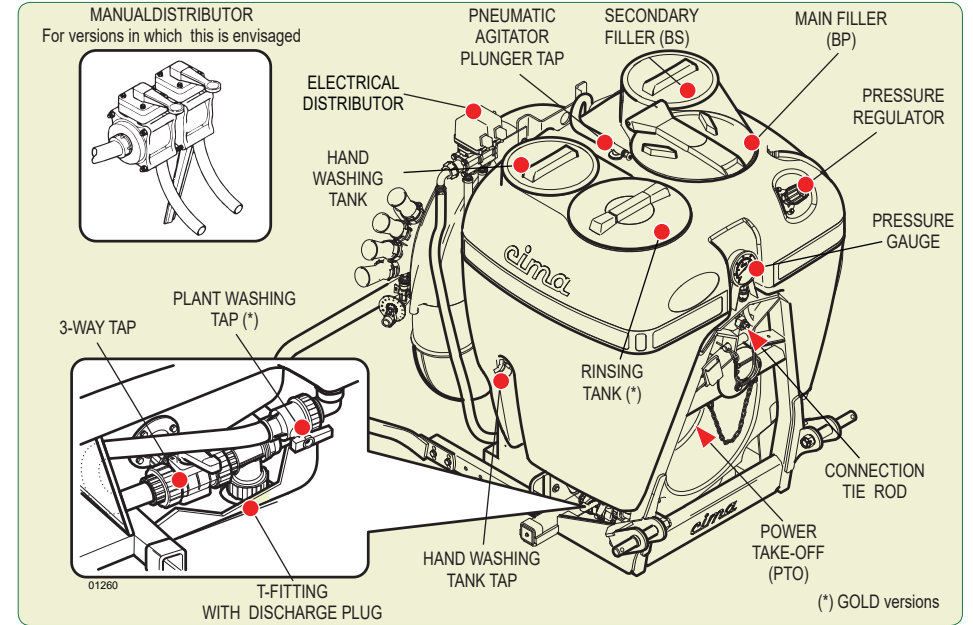
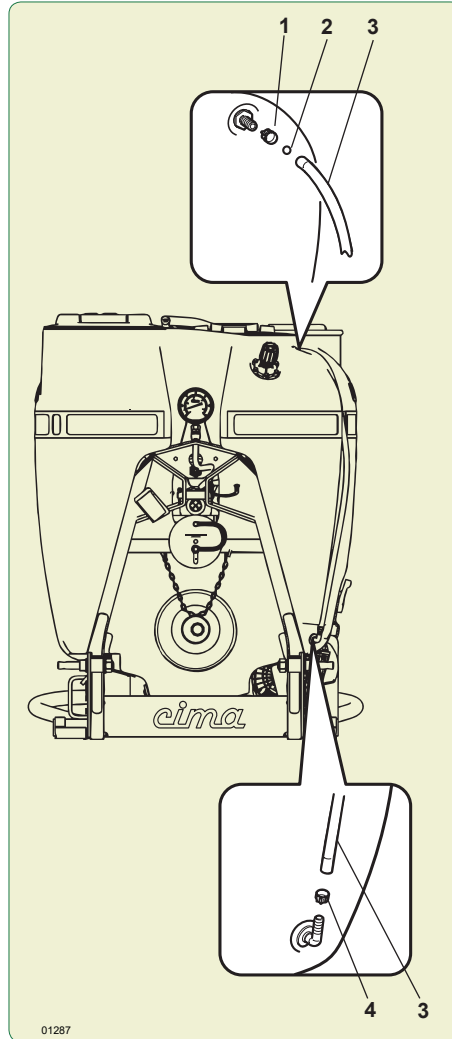

### 4.1 FRAME

The frame of the New Plus sprayers represents the framework of the machine. The accommodation and the fixing for the gearbox – fan casing group, the tank, the pump and the hydraulic circuit, are got out of the frame. The frames of the New Plus sprayers can be matched both with hydraulic hoist class "1" (diameter of the pins 22 mm and pin of the third point diameter of 19 mm) and with hydraulic hoist class "2" (diameter of the pins 28,5 mm and pin of the third point diameter of 25 mm): all the pins are provided with adapter bushes.

A rear bumper is provided to protect the sprayhead. This must be mounted in the most effective position, according to the operating conditions and in keeping with the type of heads utilised. A chain with hooks, fixed to the front part of the frame, allows the support of the transmission joint when the machine is coupled to the tractor. All frames are pre-set with axles for the application, of a pair of wheels on request (see Paragraph 7.2).

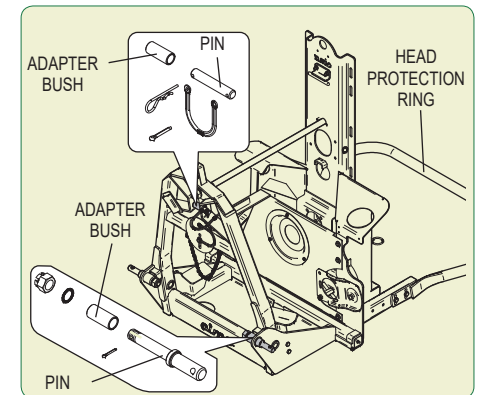

## 4.2 FAN SERVO AMPLIFIER

### Servo amplifier

It is equipped with an automatic tensioner of the driving poly-V belts that keeps the belt tension constant, avoiding slipping and wear. **A overrunning clutch is included** between the Power Take-off of the servo amplifier and the fan control pulley (for versions on which it is foreseen). In case of sudden decelerations or unexpected engine stoppage, this allows the fan to continue its free rotation, thus avoiding extreme mechanical stresses to be transmitted to the drive members.

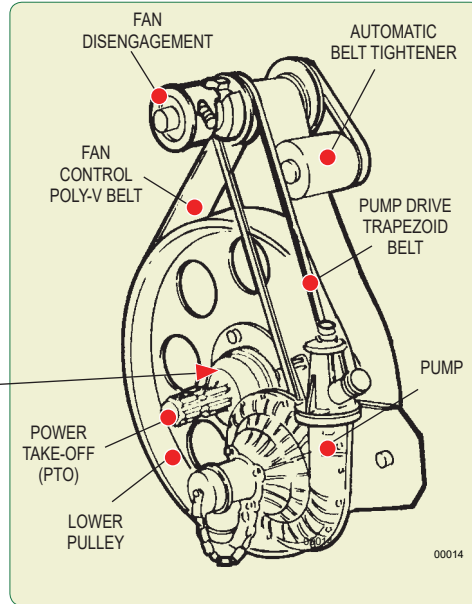
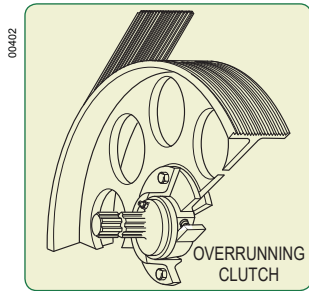

### Centrifugal fan

The front-engaging clutch assembled on the fan shaft allows the operation of the centrifugal pump without the fan. (for versions on which it is foreseen).

An air intake predisposed on the casing external edge is connected, by means of a pipe equipped with a cock, to the tank inner agitator.

Through this tap it is possible to carry out or exclude pneumatic agitation.

The closed blades' impeller is sheet steel realized and dynamically balanced; the air intake opening on the casing is protected by a steel grating.

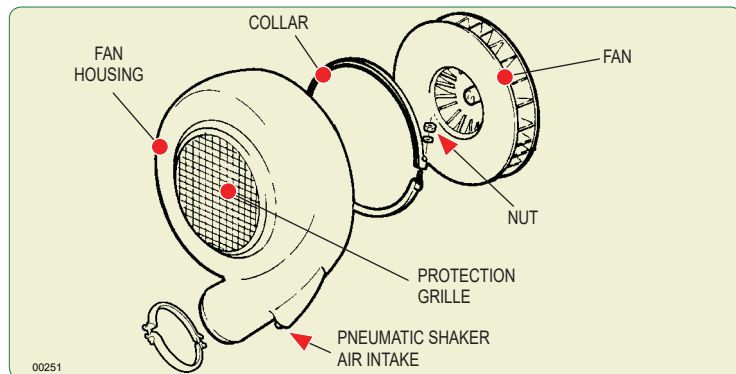

## 15.4 INSPECTION AND CLEANING PUMP FILTER



The pump is provided by the suction side of a filter to prevent the accidental entry of foreign bodies in the pump body, such a possibility does not constitute a hazard and can only cause damage to the impeller shown by a drop in pressure reported by gauge.

The clogging of the filter pump causing an immediate lowering of pressure delivery.

If necessary check the cleanliness of the filter:

1. Position the lever of the three-way cock (P6) in position "C".
2. Position the lever of the three-way cock (P2) in position "C".
3. Unscrew the plug (1) and eventually remove the foreign body present in to the filter.
4. If necessary, unscrew the nuts (2) and remove the filter (4), to clean completely.
5. Replace the filter by paying attention to the conditions and the proper placement of the O.Ring (5).
6. Close the screw plug (1).
7. Position the lever of the three-way cock (P2) in position "A" - **WORKING**.
8. Position the lever of the three-way cock (P6) in position "A" - **WORKING**.

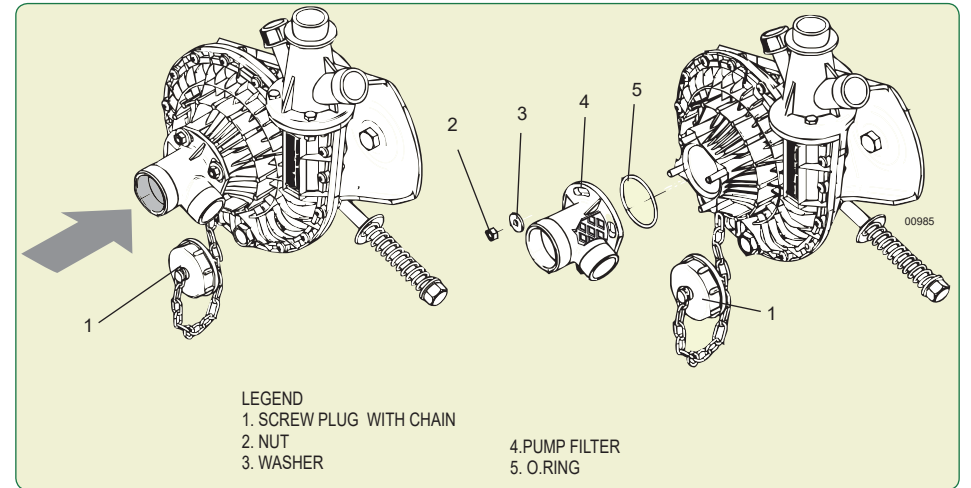

## 15.2 REPLACEMENT OF ELECTRICAL PANEL'S FUSES

1. Replace the faulty fuse and screw back the cover.

· Fuse: 10 A, delayed.



ANY OTHER INTERVENTION HAS TO BE CARRIED OUT AT A C.I.M.A. CUSTOMERS' SERVICING CENTER.

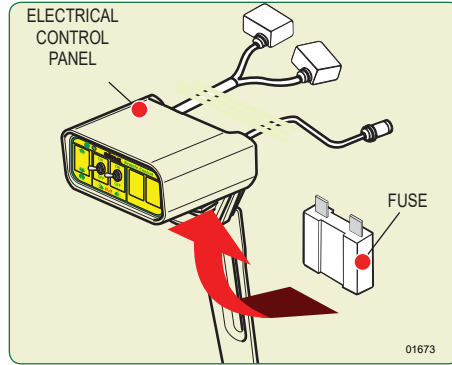

## 15.3 PRESSURE GAUGE REPLACEMENT

1. Unscrew and decouple the pipe-holder (3) from the connection of the pressure gauge (1).
2. Unscrew the ring nut (2) and remove the pressure gauge (1).
3. Replace the faulty pressure gauge (1).
4. Mount the new pressure gauge, by carrying out in reverse order the steps mentioned for its removal.

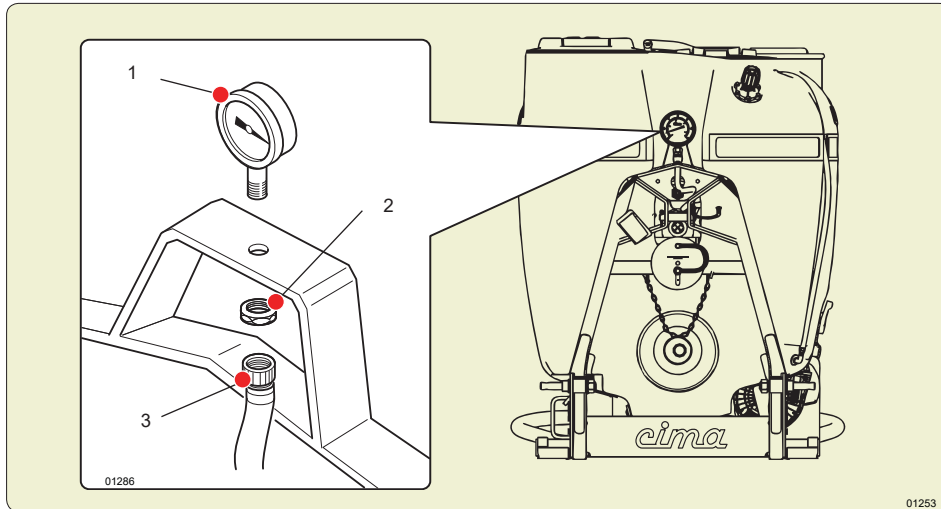

ANY OTHER INTERVENTION HAS TO BE CARRIED OUT AT A C.I.M.A. CUSTOMERS' SERVICING CENTER.

## 4.3 HYDRAULIC CIRCUIT

### 4.3.1 Operating principle

**WORK** – The tank (P1) contains the mixture that need to be sprayed on the growings to treat. The tank (P1) is connected with the pump (P4) by the 3-way tap (P2). When the tap (P2) is in position “A” - **WORK**, the mixture is sucked by the pump (P4) and sent to the pressure regulator (P5) and to the distribution device (sprayhead) through the 3-way tap (P6).

The regulator (P5), together with the correct position of the rotating disc regulator, allows to modify the spraying pressure of the sprayer so to can reach the correct litres/hectare distribution needed. The exceeded quantity of the liquid supplied by the pump through appropriate pipes is directed inside the tank in order to maintain as constant the mixing agitation.

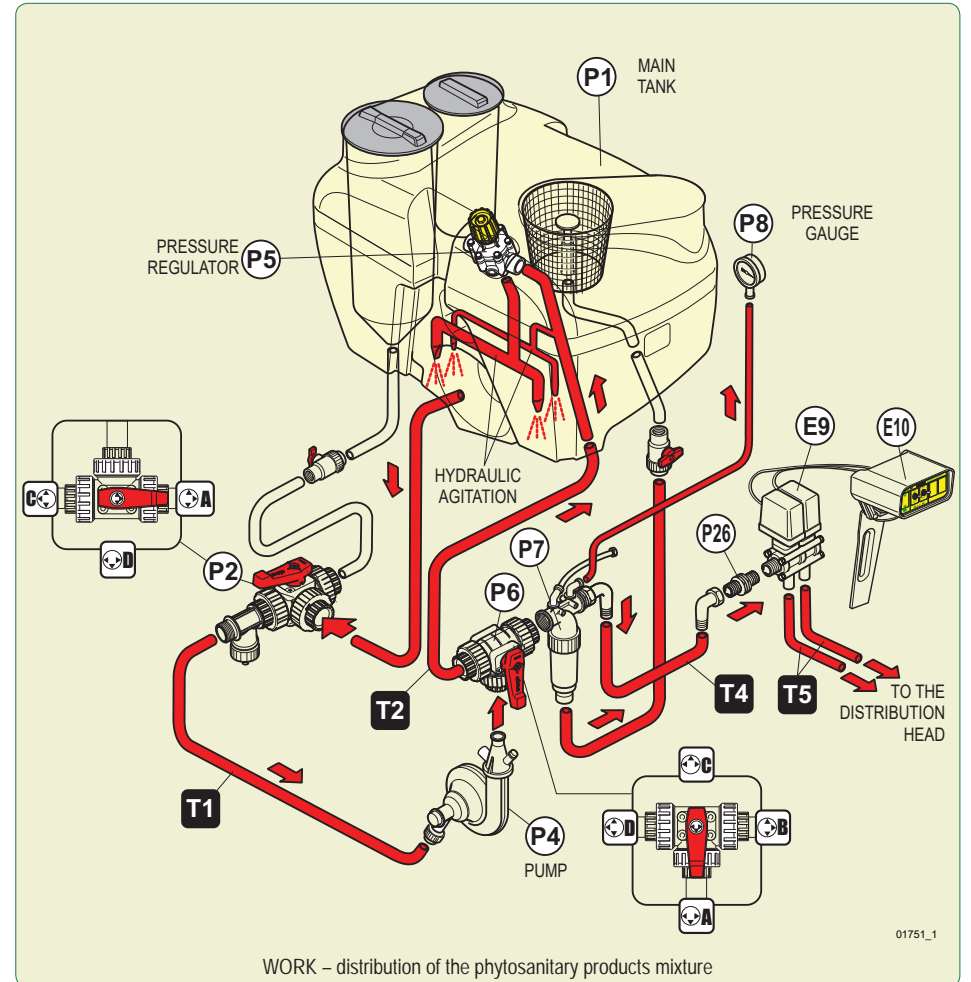

On the delivery to the distribution device (sprayhead), after the pump, the delivery filter is placed (P7); from the filter through the pipe (T4), the mixture to spray reaches the electrical distributor (or manual P9 for versions on which it is foreseen) that allows the mixture spraying (when open). The connection to the gauge (P8) for the spraying pressure control is derived from the filter's body (P7).

**MIXING:** from the base of the filter depart the pipe (T6) that connects the pump's delivery (P4) through the tap (P12) to the mixer agitator on the main union (on versions on which it is foreseen).

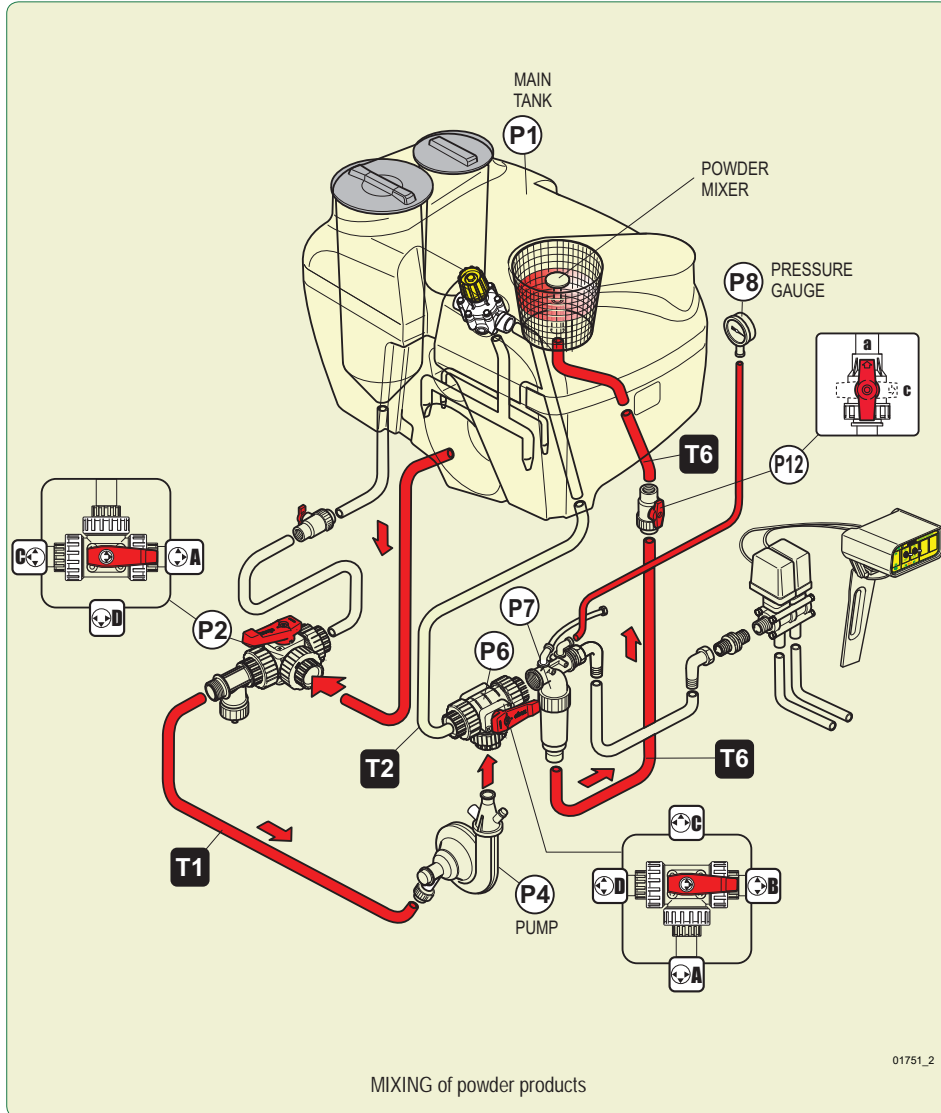

15 REPAIRS ALLOWED 15



**THE OWNER AND/OR THE OPERATOR OF THE SPRAYER ARE NOT PERMITTED TO MODIFY THE STRUCTURE OR THE SPECIFIC OPERATION OF THE SPRAYER ITSELF. ANY REPAIRING INTERVENTION HAS TO BE CARRIED OUT EITHER AT THE DEALERS' OR AT THE C.I.M.A. S.p.A. AUTHORIZED WORKSHOPS, OTHERWISE ANY KIND OF WARRANTY IMMEDIATELY CEASES AND C.I.M.A. S.p.A. IS CLEARED OF ANY CONSEQUENT AND/OR IMPLIED RESPONSIBILITY.**



**Stop the engine and remove the key from the tractor's control panel before any operation on the sprayer.**

15.1 REPLACEMENT OF PUMP CONTROL BELT

1. Remove the steel-plate guard located on the frame behind the pump, unscrewing the two securing screws.
2. Completely unscrew the tightener spring adjusting screw: the pump support plate will so freely turn.
3. Unscrew the fixing screw and turn the mobile protection cover to approach the tunnel of the disengagement.
4. Insert the pump control belt into the tunnel of fan disengagement. Feed the front part below the disengagement area and the rear area above, until it enters the upper pulley groove beyond the disengagement portion.
5. Insert the belt in the pump's pulley groove.
6. Reinstall the spring of the belt-tensioner according to the suggested tensioning conditions.
7. Re-assemble the steel-plate protection guards.

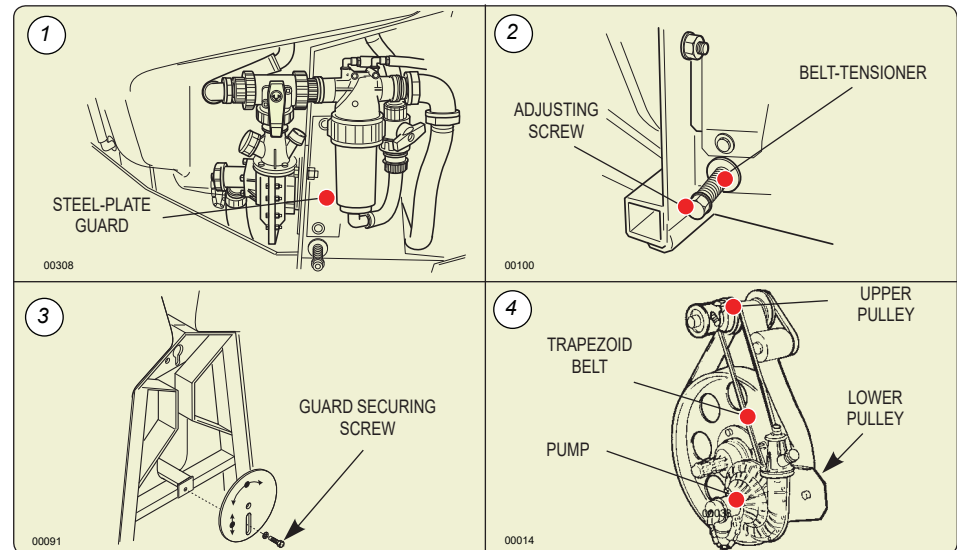

**Carefully tighten the screws that were undone during the belt replacement.**



- 1b. CAUSE: Electrical distributor (E9) taps blocked by incrustations in the closed position.  
**REMEDY:** Remove the cover, act on the opening/closing control rod.  
*Clean the distributor.*
- 2. CAUSE: Fuses of the electrical control panel (E10)  
**REMEDY:** Replace the fuses.
- 3b. CAUSE: Power cable W1 of the electrical panel interrupted or oxidized connectors of the electric distributor (E7)  
**REMEDY:** Connect and possibly replace the defective components correctly.
- 4. CAUSE: Defective electrical connections.  
**REMEDY:** Address a C.I.M.A. point of "Sale and Service".
- 5. CAUSE: Pump defective (only in case total delivery missing).  
**REMEDY:** Address a C.I.M.A. point of "Sale and Service".
- 6. CAUSE: Broken pump belt.  
**REMEDY:** Replace the belt (See Paragraph 15.1).



**THE CAUSES AND REMEDIES FOR THE FAULTS CONCERNING THE DELIVERY OF THE SPRAYING BY ONE OR MORE DIFFUSERS ARE INDICATED IN THE USE AND MAINTENANCE MANUAL OF EACH SPRAYHEAD.**

**K. FAULT: Anomalous consumption of oil of the fan support.**

- 1. CAUSE: Oil drain plug not adequately closed.  
**REMEDY:** Check, reposition and adequately close then handle the filling up of the oil level.
- 2. CAUSE: Damaged flexible oil waste pipe or damaged pipe fixing clamp.  
**REMEDY:** Check, adequately then handle the filling up of the oil level. Replace the damaged parts: Address a C.I.M.A. point of "Sale and Service".
- 3. CAUSE: Drawings from the support mechanical seals.  
**REMEDY:** Address a C.I.M.A. point of "Sale and Service".

**L. FAULT: Noisiness (ticking) coming from the upper part of the mechanical drive at low runnings, above all when slowing down.**

- 2. CAUSE: Consumption of the damping elements of the fan release.  
**REMEDY:** Eventually have it replaced; address a C.I.M.A. point of "Sale and Service".

**M. FAULT: Noisiness (ticking) coming from the lower part of the mechanical drive at low runnings, above all when slowing down.**

- 1. CAUSE: Lack of grease in the multiplier free wheel.  
**REMEDY:** Grease the free wheel.

**CIRCUIT WASHING** – In the GOLD version the spray-line rinsing tank (P17), included in the main tank (P1), is connected through the 3-way tap (P2) to the pump (P4); by operating on the tap (P2) and opening the tap (P15) it is possible to exclude the main tank and fuel the pump (P4) with the clean water contained in the circuit-washer tank, so to allow the washing of the distribution circuit also in case the main tank is full or partially filled.

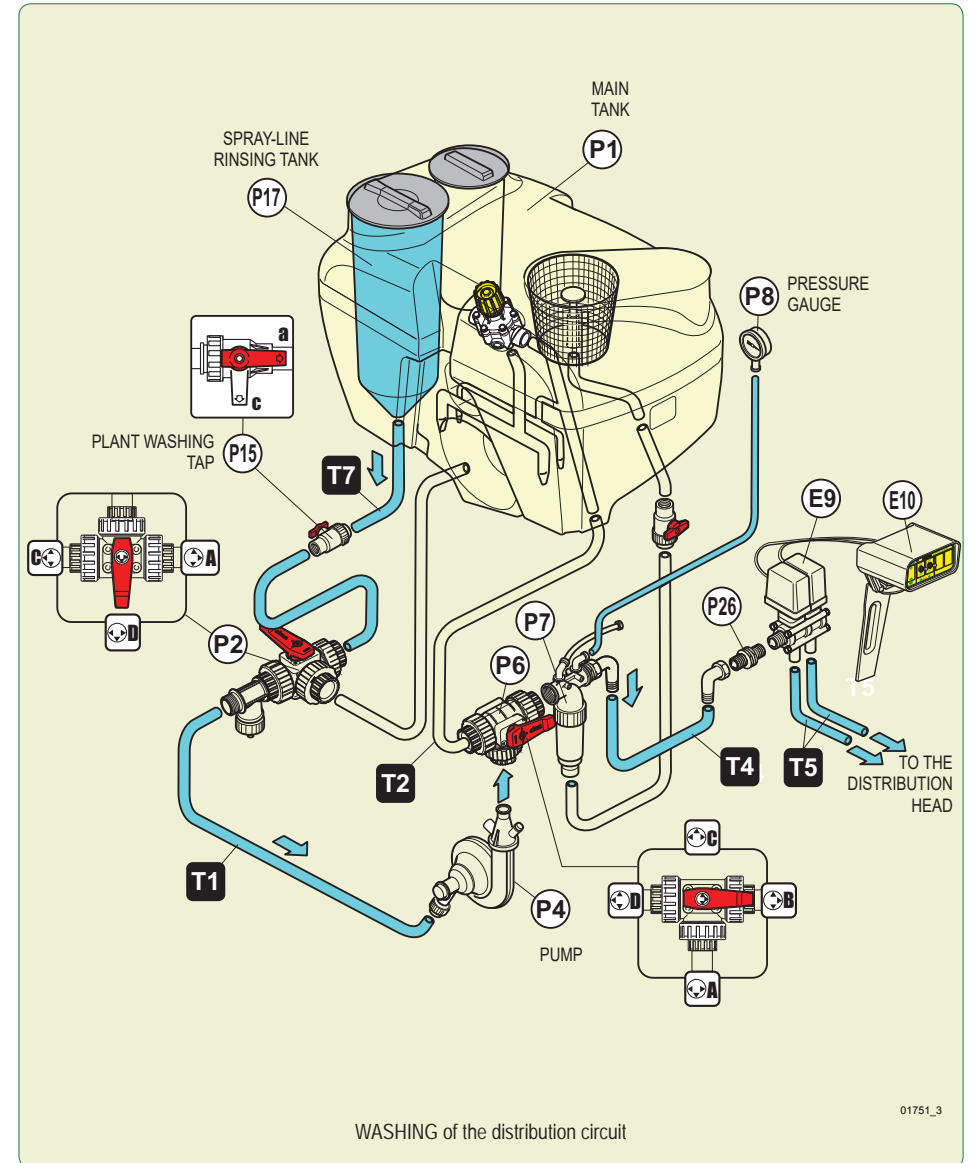

**FILLING** (with filling pipe). The filling pipe (TR) (accessory) can be connected to the pump (P4) to fill the tank by collecting the water needed for the dilution of the phytosanitary products mixture from an external tank, from a well or from a canal/channel (in case provided for by the regulations in force in the country where the machine is in use).

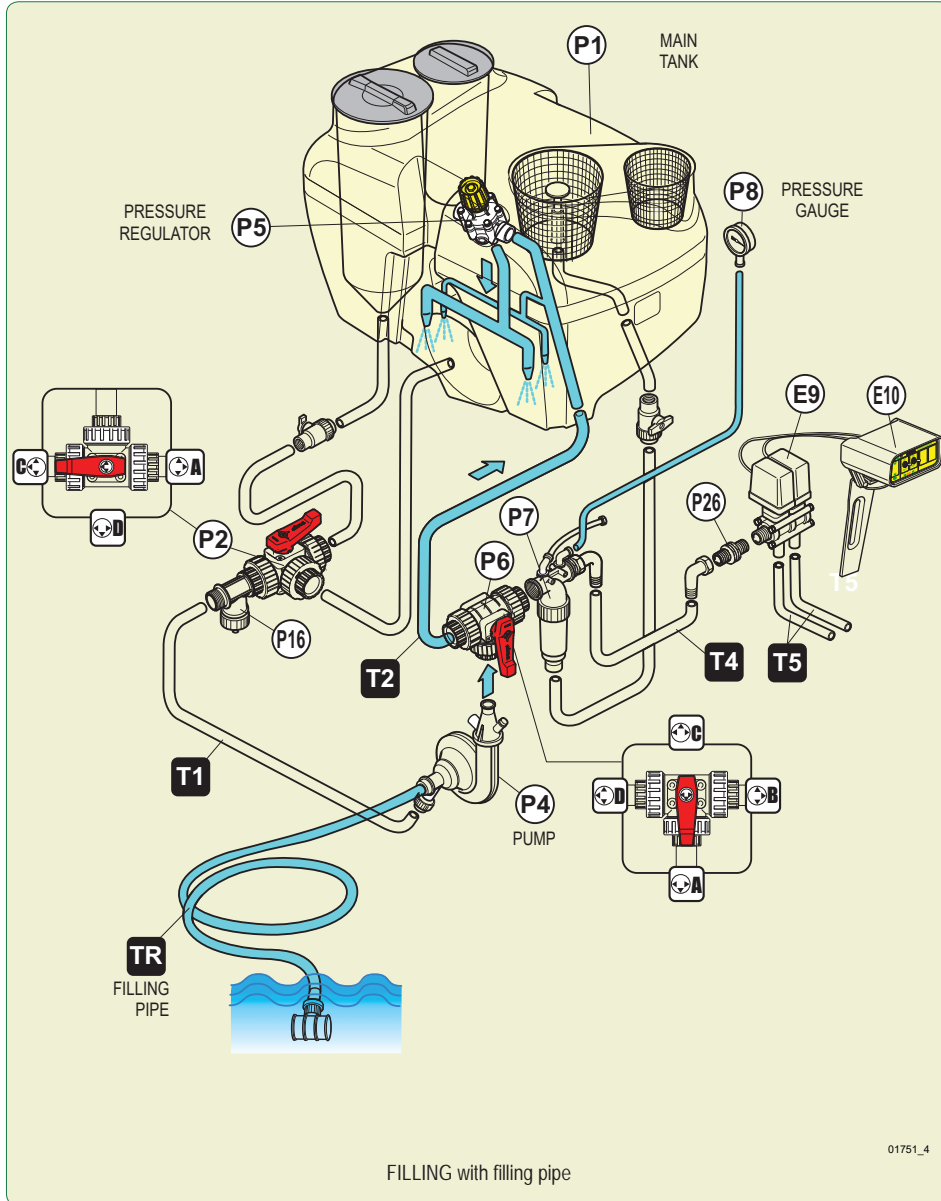

2. CAUSE: Residue of product at the entrance of the gauge  
**REMEDY:** Clean.
3. CAUSE: Wrong positioning of the circuit-washer faucet (P15) with the circuit-washer tank empty.  
**REMEDY:** Position the lever of the faucet correctly (P15 - pos". 1") and fill the circuit-washer tank.
4. CAUSE: Lack of seal of the O-Ring gasket of the pump suction connection (cone).  
**REMEDY:** check the correct assembling and the efficiency of the O-Ring gasket, if necessary replace the gasket.

**E. FAULT: Vibrations of fan unit.**

1. CAUSE: The tractor and of the atomizer PTOs are not lined up or their position determines the overcoming of the maximum work angle of the drive cardan shaft.  
**REMEDY:** Raise or lower the sprayer in order to realign PTO so that cardan shaft functions correctly (see Paragraph 5.2).

**F. FAULT: Anomalous and continuous noisiness together with vibrations of the fan group.**

1. CAUSE: Breaking of the fan shaft bearings.  
**REMEDY:** Address a C.I.M.A. point of "Sale and Service".
2. CAUSE: Interference fan - case.  
**REMEDY:** Address a C.I.M.A. point of "Sale and Service".

**G. FAULT: Intermittent operation of the whole distribution device**

1. CAUSE: Lack of seal of the hydraulic circuit that goes from the tank (T1) suction pipes to the manual distributor (P9) or to the electrovalves (E9)  
**REMEDY:** Carefully inspect all the points at which suction of air can take place, including as well those at which no liquid seepage is detected. Check the proper tightening of ring nuts, fittings and clamps. Check the efficiency of the sealers and the integrity of the piping. Reinstate the efficiency and replace parts that might have been found to be defective.

**H. FAULT: Intermittent spraying only on the one side of the distribution device**

1. CAUSE: Faulty sealing of the hydraulic circuit going from the manual (P9) or electrical (E9) distributor to the distribution point involved.  
**REMEDY:** As per point G.1.

**I. FAULT: No spraying action delivered: totally.**

1. CAUSE: Clogging up of the grill/filter on the pump, of the pump suction inside the tank or suction pipes of pump clogged up with deposits of hardened plant protection product.  
**REMEDY:** Clean.

**J. FAULT: No spraying action delivered: totally or only on the one side of the distribution device**

1. CAUSE: Manual distributor (P9) taps dirty or clogged, or pump suction piping clogged by hardened product deposits.  
**REMEDY:** Clean.

**A. FAULT:** By utilising the filler piping the pump doesn't operate (suction)



It is necessary to disengage the drive outlet (PTO) and wait for it to stop rotating before repeating the filling operation.

1. CAUSE: the quantity of water poured into the tank is insufficient to trigger the pump.  
**REMEDY:** Add water to the tank until the pump starts its cycle.
2. CAUSE: the filler piping sucks in air.  
**REMEDY:** Completely submerge the suction filter of the filler piping.
3. CAUSE: Lack of seal of the pipes.  
**REMEDY:** Check the tightening of ring nuts, fittings and clamps. Check the efficiency of sealers and that piping elements are not cracked or broken. Replace parts that are possibly found to be defective.
4. CAUSE: Slipping of the pump's belt.  
**REMEDY:** Check the tension of the belt-tensioner's spring. (4÷5 cm).
5. CAUSE: The pump's belt might be broken.  
**REMEDY:** Replace the belt.

**B. FAULT:** Leakage and dripping from the pump

1. CAUSE: Non-sealing of the fittings and clamps connecting the piping to the pump.  
**REMEDY:** Check for proper tightening of ring nuts and clamps. Check the efficiency of the sealers. Replace parts that are possibly found to be defective.
2. CAUSE: Mechanical sealing defective.  
**REMEDY:** Address a C.I.M.A. point of "Sale and Service".

**C. FAULT:** Drop in pressure of the hydraulic circuit signalled by the gauge

1. CAUSE: Dirty filter.  
**REMEDY:** Clean the cartridge
2. CAUSE: The pump filter is clogged.  
**REMEDY:** Clean the filter
3. CAUSE: Faulty sealing of the hydraulic circuit.  
**REMEDY:** Check the operation of the pump and the tension of its belt. Check the proper tightening of ring nuts, fittings and clamps. Check the efficiency of the sealers and the integrity of the piping. Replace the parts that are possibly found to be defective.
4. CAUSE: Gauge defective.  
**REMEDY:** Replace the pressure gauge.
5. CAUSE: Suction or gauge connection pipe clogged.  
**REMEDY:** Clean.

**D. FAULT:** Variations in the pressure of the hydraulic circuit (marked by the gauge)

1. CAUSE: Lack of seal of the pipes and/or the valves.  
**REMEDY:** Check the clamping of the ring nuts, the connections and the clamps. Verify the efficiency of the gaskets and the integrity of the pipes. Replace the possibly defective parts.

4.3.2 Hydraulic circuit components

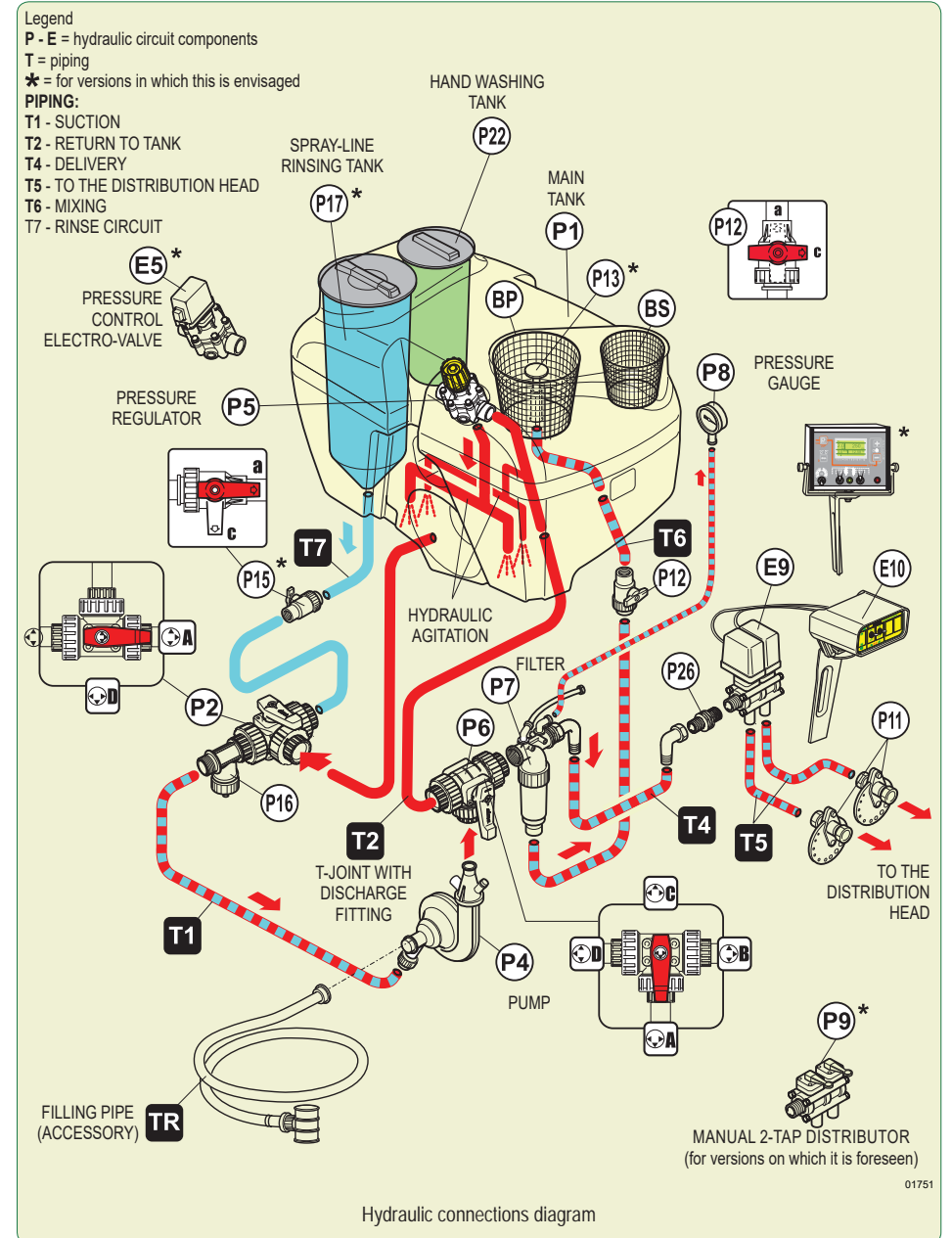

**P1. TANK**

Tanks utilised:  
polyethylene tanks of 300, 400 and 600 litre capacity.

Each tank is made up of:

- tank main filler (BP) spout of 355 mm diameter, with collapsible lid, breather and labyrinth seal, for the filling with spraying products. Plastic cup-like filter: 302 mm external diameter, height 254 mm with powder mixing device (for versions on which it is foreseen);
- supplementary tank filler (BS) with 255 mm diameter screw-type lid, for filling with clear water and plastic cup-like filter: external diameter 204 mm, height 240 mm;
- hydraulic agitation system connected to the regulator (P5) and to the pump (P4).
- transparent level indicator external pipe with graduated scale;
- pneumatic agitation, connected to the piston tap found above the tank and connected through piping to the air intake located on the fan casing.

**A = OPEN**  
**C = CLOSED**

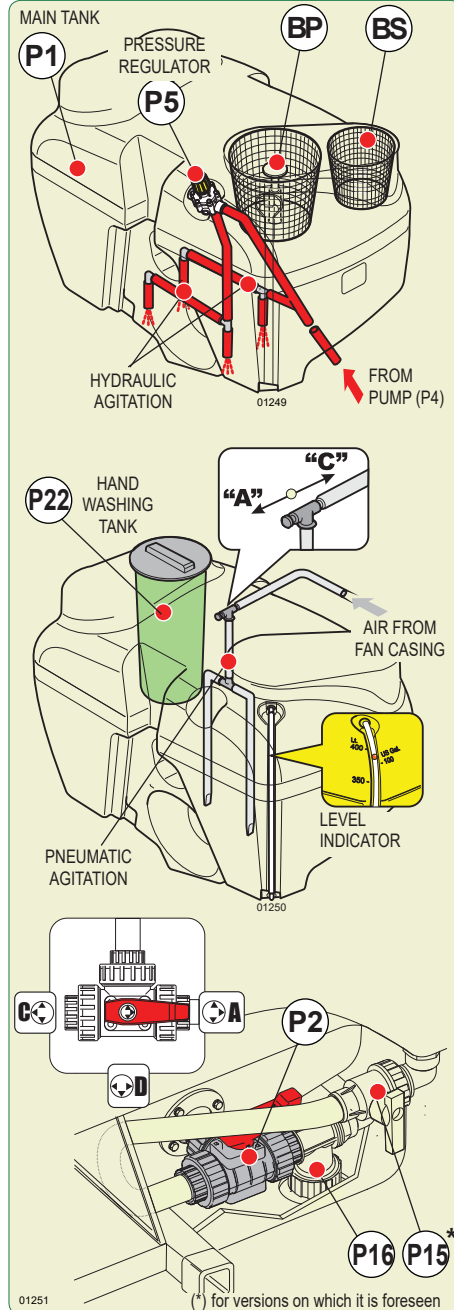

**P22. HAND WASHING TANK**

Incorporated polyethylene 17 litre capacity hand wash tank, with external service tap; opening through a 255 mm diameter screw lid.

**P2. 3-WAY LEVER TAP**

Fixed to tank (P1) and connected to the suction piping (T1).



**When the sprayer is working the lever tap must ALWAYS be oriented toward the suction pipe, in "A - WORKING" position.**

The different positions of tap (P2), displayed on the decal placed on the machine, are as follow:

- A - WORKING**  
(phytosanitary products distribution).
- D - CLEANING CIRCUIT**
- C - CONNECTION/DISCONNECTION FILLING PIPE**

**13.9 TABLE OF MAINTENANCE OPERATIONS**

CHECK	SEASON START TREATMENTS	BEFORE EVERY TREATMENTS	END OF EVERY TREATMENTS	SEASON-END TREATMENT	RECOMMENDED FREQUENCY
Fan belt-tensioner spring: CHECK LENGHT 9-12 cm	YES	YES	**	**	**
Pump belt-tensioner spring: CHECK LENGHT 4 - 5 cm	YES	YES	**	**	**
Fan shaft support: CHECK OIL LEVEL	YES	YES	**	**	8 hours
Fan shaft support: CHANGE OIL	**	**	**	YES	1 year
Tank: CHECK SECURING TIE ROD AND ANCHORING BRACKET	YES	YES	**	**	**
Fan belt-tensioner support: GREASING	**	**	**	YES	1 year
Free wheel: GREASING	**	**	**	YES	1 year
Filter: CHECK CLEANING	YES	YES	YES	YES	**
Tank level gauge: CHECK CLEANING AND GOOD CONDITIONS	YES	YES	YES	YES	**
Fittings and piping: CHECK GOOD CONDITIONS	YES	YES	**	YES	**
Fixed and mobile parts, clamps and fittings: CHECK FOR INTEGRITY, PERFECT SEALING AND TIGHTENING	YES	YES	**	**	**
Wheels: CHECK THE SCREW NUTS TIGHTENING AND TYRES PRESSURE	YES	YES	**	YES	**
Axle and wheel hubs: CHECK THE SCREWS AND NUTS TIGHTENING	YES	YES	**	YES	**
Hydraulic circuit and tank: COMPLETELY DRAIN AND WASH	**	**	YES	YES	**
Sprayer: EXTERIOR WASHING	**	**	YES	YES	**
Sprayer: STORAGE	**	**	**	YES	**

### 13.8 TANK REMOVAL OR REPLACEMENT



It is recommended to have the operation performed by a C.I.M.A. assistance point, such a regulation is compulsory in case of REPLACEMENT of the tank.



The operation has to be carried out by complete absence of liquid residuals both inside the tank and in the hydraulic circuit.

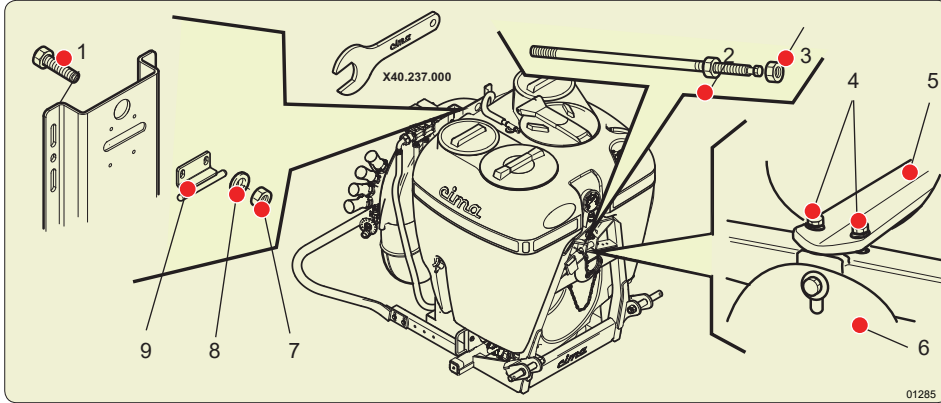

**Removal:**

1. Free the tank of its hydraulic and pneumatic connections.
2. Dismantle the mobile protection cover (6) of the coupling.
3. Remove the tank securing bracket (5), undoing the two screws (4) and the relevant washers.
4. Remove the tank securing bracket (9), undoing the two screws (1), the nuts (7) and the relevant washers (8).
5. Undo the external nut (3) of the tie rod.
6. Tighten the internal nut (2) of the tie rod, utilising the spanner provided (nr. X40.237.000 ), moving it away from the plate.
7. Undo the tie rod from its securing point, located in the rear part of the frame. Remove it through the large hole on the frame's plate.
8. Remove the tank.

**Installation:**

1. Position the main tank on the frame.
2. Re-position the tie-rod in its seat, in other words the smaller one, first inserting it through the big hole.
3. Tightly screw in and secure the tie rod to the rear plate of the frame.  
N.B. Lock tightly and with utmost care
4. Unscrew the internal nut (2) of the tie rod, slightly tightening it against the plate.
5. Securely tighten the external nut (3) of the tie rod against the plate.
6. Reassemble the tank's securing bracket (9), fastening it with the 2 screws (1).
7. Reassemble the tank's securing bracket (5), fastening it with the 2 screws (4).



Before every intervention, check the proper tightening of the 2 securing screws of the tank's mounting bracket.

8. Reassemble the mobile protection lid of the disengaging device, by securing it with the relevant screw.
9. Reinstall the hydraulic and pneumatic connections.

### P16. T-FITTING WITH DISCHARGE PLUG

Connected to the suction pipe (T1) of the tank and fixed to the 3-way tap (P2), it allows to drain the tank..



**WARNING:** the tank contains PHYTOSANITARY PRODUCTS. Discharge in an area equipped with catch basin and provide to draining in the scrupulous respect of the local regulations in force.

In the versions with circuit-washer it is possible also the drain of the sole circuit-washer tank through the fitting (P16)..

### P4. CENTRIFUGAL PUMP

Fixed to the left-hand side of the machine, it is connected to the tank through the pipeline (T1), to the three-way faucet (P6) and to the hydraulic agitation system for the mixture. The pump is provided by the suction side of a filter to prevent the accidental entry of foreign bodies in the pump body, such a possibility does not constitute a hazard and can only cause damage to the impeller shown by a drop in pressure reported by gauge.



**THE PUMP MUST NEVER RUN DRY**

The water must be always in the pump : ALWAYS check this point carefully at the start up and during the functioning.

**To avoid any damage to the pump:**

- At the first filling and at every next filling after the hydraulic circuit draining, fill the tank with an appropriate quantity of water to fill the pump completely; to do so, remove the cap from the pump body and allow water into the tank until it comes out of the pump's filler; refit the cap on the filler.
- In order to control that the pump is not running dry, AFTER engaging the PTO, check that the pressure gauge (P8) shows an operating pressure value above 0 (zero); otherwise, STOP THE PTO IMMEDIATELY.

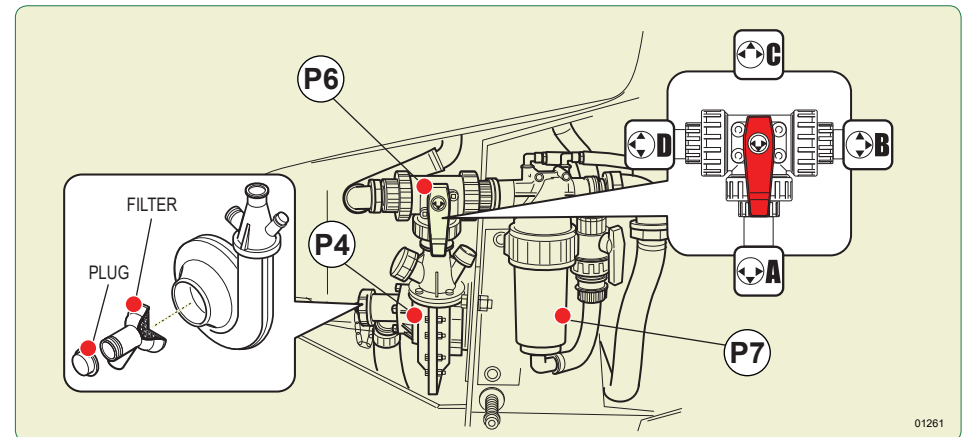

### P6. 3-WAY LEVER TAP

It is mounted on the centrifugal pump (P4) and is connected to the body of the filter (P7). The different positions of tap (P6), displayed on the decal placed on the machine, are as follow:

- A - WORKING (phytosanitary products distribution).
- B - MIXING POWDER
- C - PIPE FILLING USE
- C - FILTER MAINTENANCE

### P5. MANUAL PRESSURE REGULATOR

It is mounted on the tank and is connected to tap (P6) through piping T2. It regulates the operating pressure by controlling the return flow to the tank.

- **By closing it:** it reduces the return flow to the tank and **INCREASES the operating pressure** and capacity flow to the head (rotate the handle clockwise).
- **By opening it:** it increases the return flow to the tank while **REDUCING the operating pressure** and capacity flow to the head (rotate the handle anti-clockwise).

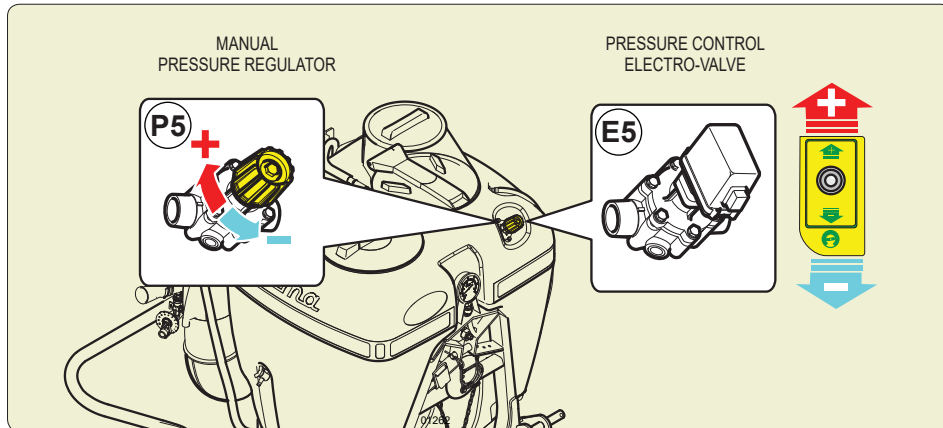

### E5. PRESSURE CONTROL ELECTRO-VALVE

(for versions in which this is envisaged)

It is mounted on the tank and connected to the cock (P6) through the pipe (T2). It adjusts the operating pressure checking the backflow into the tank.

- **Moving the joystick upwards (+)** on the electrical control gearbox, **the electrovalve closes:** in the tank both the backflow and the agitation decrease while **the values of the working pressure and the delivery to the sprayhead increase**.
- **Moving the joystick downwards (-)** on the electrical control gearbox, **the electrovalve open:** in the tank both the backflow and the agitation of the mixture increase while **the values of the working pressure and the delivery to the sprayhead decrease**.

### 13.6 FAN BELT TENSIONER

Check length "L" of the spring (refer to Picture): it should be in tension between **9 and 12 cm**.



If the fan control belt has to be replaced, the correct tensioning of the same one (spring length) has to be **OBLIGATORILY** checked after the first and after the second operation hour. If the value measured exceeds 12 cm, tighten the belt tightener screw, up to get the minimum length (9 cm).

The belt setting will take place within the first 2+3 operating hours; when that time has elapsed, verify the spring length, according with the time intervals (periodicity) indicated in the "Maintenance operations' table".

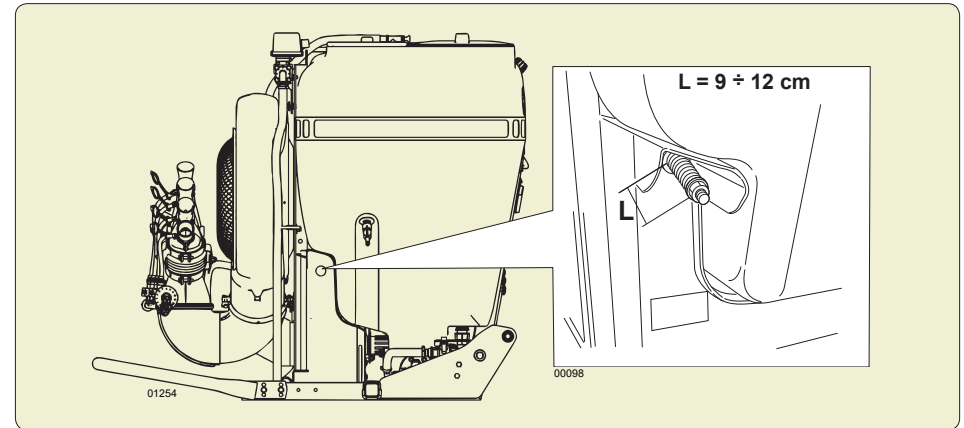

### 13.7 PUMP BELT TENSIONER

Check length "L" of the spring (refer to picture): it should be in tension between **4 and 5 cm**.

If the value measured exceeds 5 cm, tighten the belt tightener screw, up to get the minimum length (4 cm).

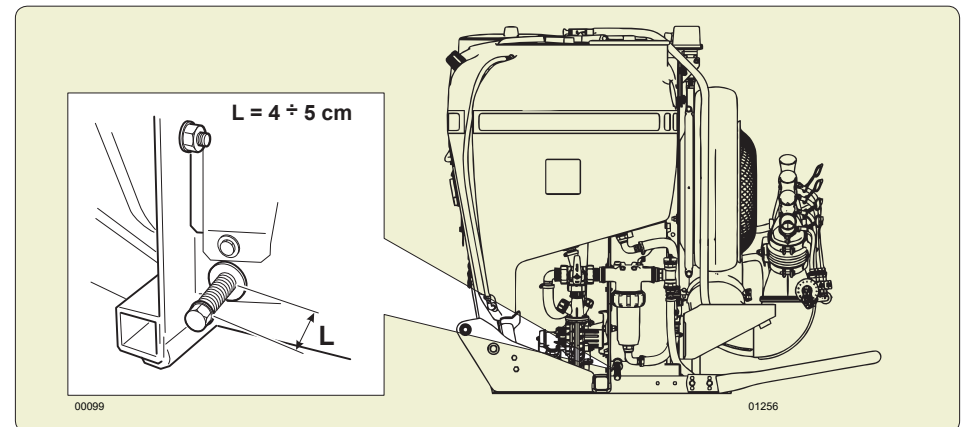

### 13.4 CLEANING OF FILTER'S CARTRIDGE

1. Set the lever of 3-way tap (P6) to the "D" position
2. Verify that the faucet (P12) of the powders mixer (or the faucet of the self-cleaning filter P25 - for versions on which it is foreseen) is closed.
3. Close the manual distributor's taps (P9) or position the switches of the control electric switchboard (E10) on "OFF"
4. Undo the thumb screw and remove the body of the filter.
5. Extract the cartridge: clean the grill and the retaining O.Ring.
6. Reassemble the cartridge and secure the lid with the thumb screw. **Pay attention to the O-Ring of the lower body during the assembly:** the incorrect sealing of the filter will jeopardise the proper operation of the sprayer and cause loss of the mixture

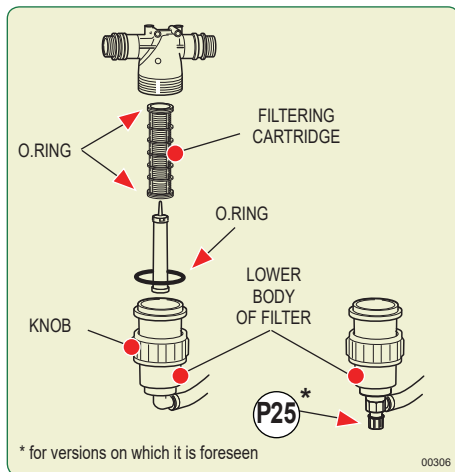

### 13.5 PURGING OF RESIDUES FROM FILTER

With the machine in operation and the taps of the manual (P9) or electrical (E9) distributor closed. Opening the powder mixer tap (P12) (or the self-cleaning filter faucet P25 - for versions on which it is foreseen) the delivery flow will drag possible sludge to the bottom of the filter within the tank through the piping (T6) thus partially cleaning the filtering cartridge. Close the tap when the operation is completed.



**When the machine is in operation, check that the drain tap (P12) (or P25) is closed before opening the main feeder.**

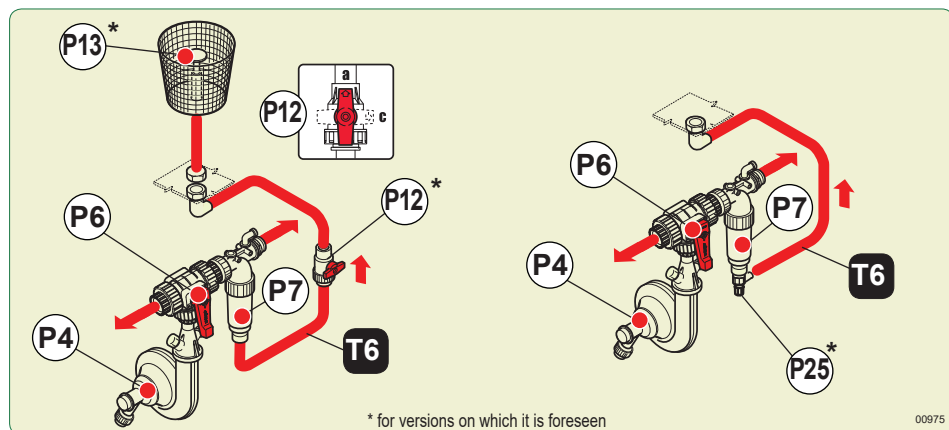

In the E.P.A. versions, the pressure regulation is **automatically** controlled by the electronic control unit (see specific manual).

### P7. FILTER

It is connected to pressure regulator (P5) and, through pipe (T4), to the distributor (E9/P9). The filter has a filtering capacity of 250 l/min., with a 32 mesh cartridge (white). The dirty cartridge causes the operating pressure chute. **This inconvenient is signalled by the pressure gauge.** Mounted on the feeding pipe, it only filters the delivery flow to the heads, by sensibly reducing the possibility for the cartridge to get obstructed. On the body of the filter there is an flexible fitting, with thread 1/4" F, to make a functional test of the gauge (P8).

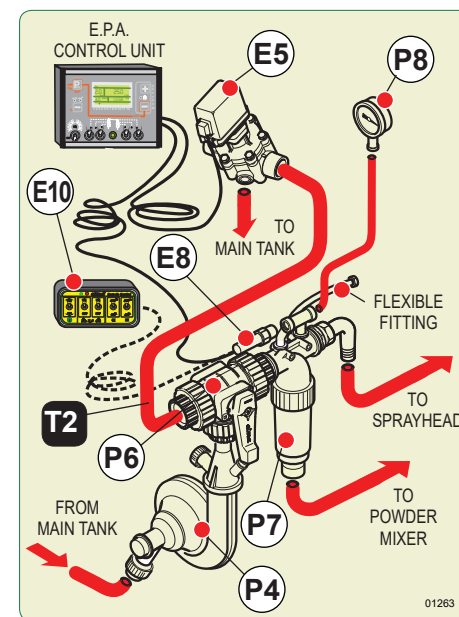

### P8. GAUGE

Glycerine-dipped, with dial from 0 to 6 Kg/cm<sup>2</sup> (atmosphere) – adjustments scale of 1/10 of atmosphere, 100 mm diameter, class 1,6%; it is connected to filter (P7).



**Set the working pressure, by acting on the regulator hand grip (P8), keeping the (P9) or (E9) opened, i.e. with the sprayhead running.**

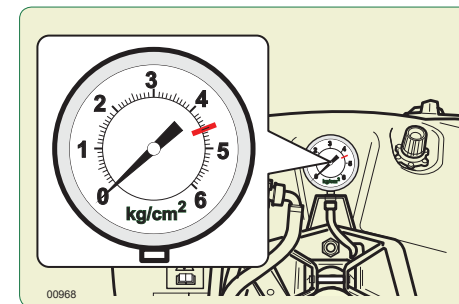

### E8. TRANSDUCER OF THE DELIVERY PRESSURE

(for versions in which this is envisaged)

In the E.P.A. versions, the pressure transducer is connected to the delivery control computer. (see the specific manual).

### P25. SELF-CLEANING FILTER FAUCET

(for versions on which it is foreseen)

It is placed in the lower part of the filter body (P7) and connects it, through the pipeline (T6), to the tank.

**a - Open, filter cleaning**

The mixture coming from the pump (P4) passes through the filter (P7) removing residual product that can cause the obstruction of the filter.

**c - Closed, treatment**

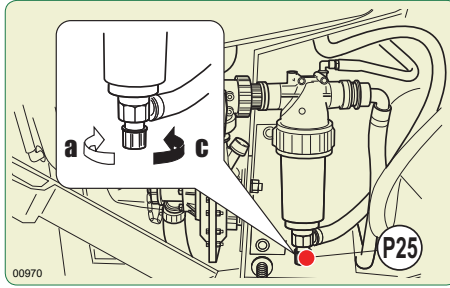

### P12. POWDER MIXER LEVER TAP

(for versions on which it is foreseen)

Positioned on the pipe (T6), between the filter (P7) and the mixer (P13) in correspondence with the inlet of the pipe into the main tank (P1); it can assume the following positions:

**a - Open (Mixing)**

From the centrifugal pump (P4), through the filter (P7), the liquid is sent to the mixer positioned on the bottom of the cup-like filter of the main filler (BP).

**c - Closed**

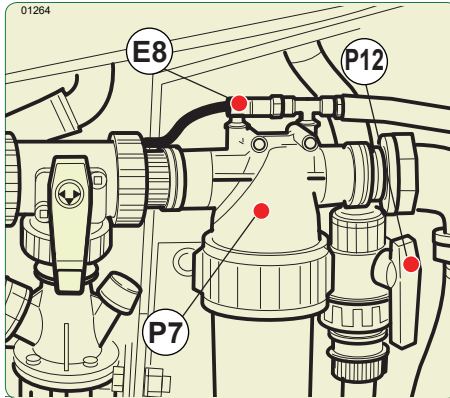

### P13. POWDER MIXER (For versions in which this envisaged)

It makes the mixing of the powdery products during the filling of the tank. It is mounted on the basket filter of the main filler (BP) and it is connected to the pump (P4) (or P19 for versions in which is envisaged) by the pipe (T6). That device consists of a fine mesh-nylon basket, which is placed inside the tank main filler (BP). The basket is equipped with a mushroom outlet, through which the filling water coming from the pump streams out. Thanks to that system, the powder products contained inside the basket get more gradually dissolved, and the building of crumbs and thickenings can be avoided.

The shower head can be replaced by a containers washing device.



**For the container washing procedure operate as for the washing of the circuit (see par. 10.4) with the tap (P6) in pos. "B" and the tap (P12) open.**

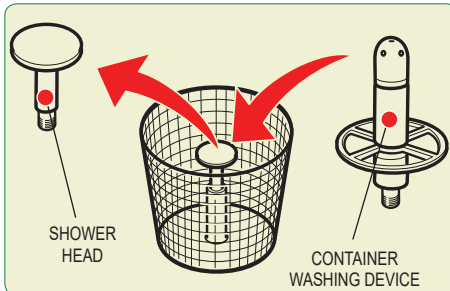

### 13.2 FAN SHAFT SUPPORT OIL LEVEL CHECK

1. Remove the oil filling plug with the dipstick.
2. Clean the dipstick and introduce it again.
3. Extract the dipstick and check the oil level, which has to be between the two minimum and maximum level notches of the dipstick itself.  
Should it be necessary to top up the level, add some SAE 90 oil, up to reach the dipstick upper notch (MAX) with oil dipstick completely inserted.



**NEVER exceed the MAX level mark of the dipstick.**

4. Reintroduce the oil filling plug with the dipstick; ensure that the oil plug locked.

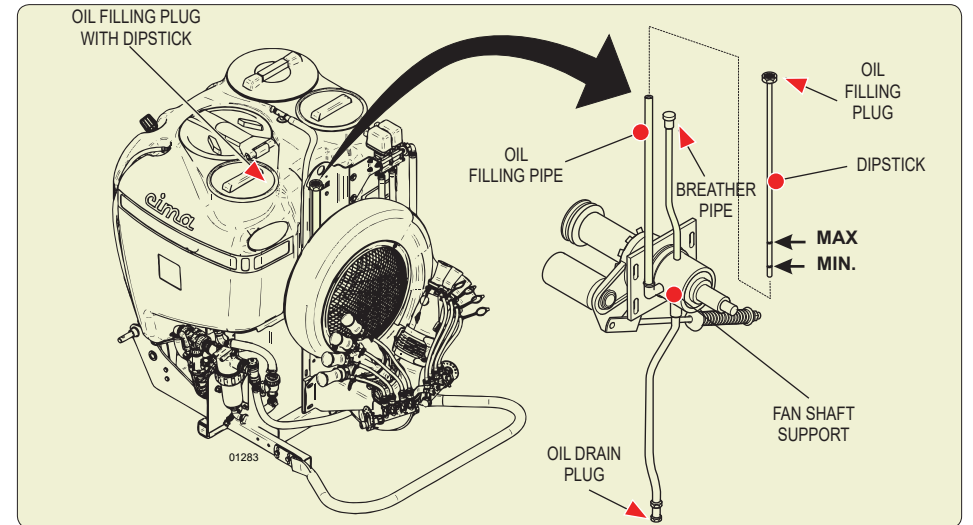

### 13.3 FAN SHAFT SUPPORT OIL REPLACEMENT



**Let the fan support oil replacement intervention be carried out at a C.I.M.A. customers' service centre, or observe the regulations in force for the disposal of the used oil.**

1. Remove the oil filling plug with the dipstick.
2. Remove the oil drain plug and let the oil completely flow out from the fan shaft support.
3. Check the oil drain plug and the relevant seal for integrity, replace them, if necessary, and close again the oil drain plug.
4. Through the filling pipe, pour a SAE 90 oil proper quantity, up to reach the MAX notch on the dipstick:
  - 0,12 liters for the NEW PLUS 42 and 45 models
  - 0,22 liters for the NEW PLUS 50 and 55 models.



**NEVER exceed the MAX level mark of the dipstick.**

5. Reintroduce the oil filling plug with the dipstick; ensure that the oil plug locked.



13 MAINTENANCE OPERATIONS 13



ALL OPERATIONS MUST BE CARRIED OUT WITH THE ENGINE SWITCHED OFF AND WITH THE IGNITION KEY REMOVED FROM THE CONTROL PANEL



The machine has to be periodically revised according to the country rules. The inspections and the release of the certificate have to be made by special provided structure of the country where the machine is used.

13.1 LUBRICATION

MAINTENANCE POINT	ACTION	COMSUMPTION MATERIAL	PERIODICITY
FAN SHAFT BEARINGS SUPPORT	Check oil level	Oil SAE 90	8 hours
FAN BELT TENSIONER SUPPORT	Greasing	Grease type EP Class NLGI 2	1 year
FREE WHEEL	Greasing	Grease type EP Class NLGI 2	1 year
FAN SHAFT BEARINGS SUPPORT	Change oil	Oil SAE 90	1 year



Carefully clean the greasing nipples and the oil filler in order to avoid that, during lubrication, dirt might be introduced. In the case of intensive use of the machine, reduce the lubrication intervals..

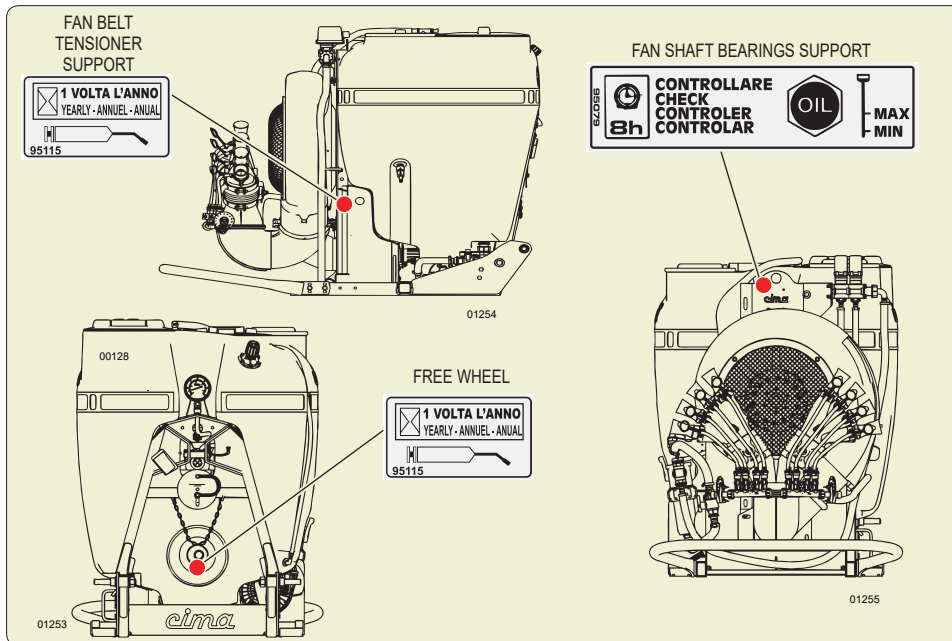

P26. NIPPLE FOR FLOWMETER CONNECTION

The 1" M/M nipple is placed between the delivery pipe for the sprayhead (T4) and the electrical distributor (E9), and it allows to disconnect the pipe and place a flowmeter between the pipe itself and the electrical distributor, to be used for the periodical revising tests.

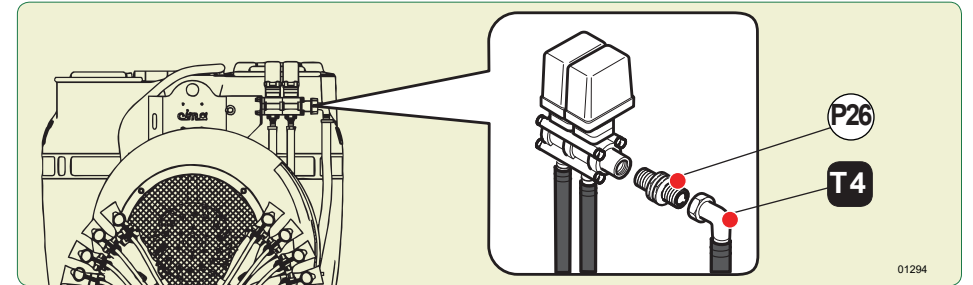

E9. ELECTROVALVES ASSEMBLY (with remote control)

It is connected with the feeding pipe (T4), the distribution pipes (T5) and the electrical unit (E10), which is fastened on the tractor. The solenoid valves open and close themselves, according with the action carried out on the electrical control unit switches.

In the E.P.A. versions, the controls of the cross section solenoid valves are situated on the electronic control unit (see specific manual).

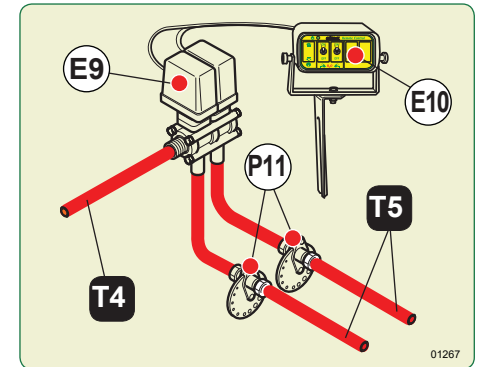

P9. MANUAL DISTRIBUTOR WITH 2 LEVER-OPERATED TAPS

(for versions in which this envisaged)

It connects the feeding pipe (T4) to the distribution piping (T5). It remote-controls the closing and opening of the pulverising. The mount bracket, supplied with the machine, must be secured to the tractor within the driver's reach. When the machine is not hitched to the tractor, it must be placed on the forward part of the sprayer's frame. Each tap permits the spraying from a single side of the head: to the right and to the left respectively.

They are **open** when the levers are set in the **vertical** position.

They are **closed** when the levers are **horizontal**.

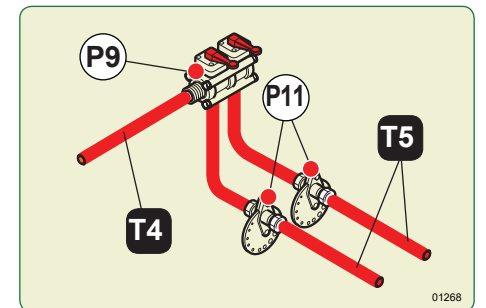

**E10. CONTROL UNIT**

Electrically connected with the distributor with 2 motor-operated valves (E9) and with the tractor's power socket. The two lever switches that control the valves (E9) must be "ON" to open and "OFF" to close. The control unit is fitted with a bayonet support to be inserted into the bracket provided. This must be fastened to the tractor within reach of the driver. When the machine is not coupled to the tractor, it must be housed in the seat on the frame at the front of the machine.

Depending on the machine/sprayhead set-up, the control unit has 2 configurations:

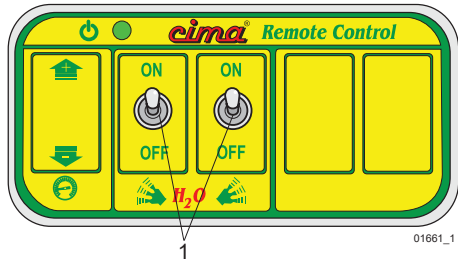

**STANDARD:**

1. distribution solenoid valves ON/OFF control.

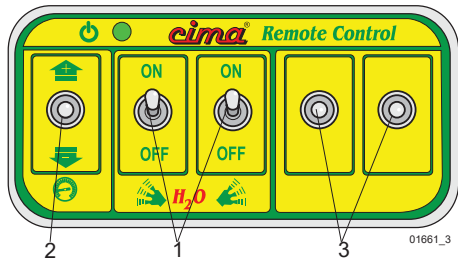

For versions **WITH ELECTRICAL PRESSURE REGULATOR (E5):**

1. distribution solenoid valves ON/OFF control;
2. pressure adjustment +/- control;
3. electrical diffusers operation (where envisaged).

The control unit has two sections for versions with **4 distribution SOLENOID VALVES**: the top for controlling distribution from the upper diffusers (4) and the bottom, which can be in standard configuration (5) or with electrical pressure regulator (6).

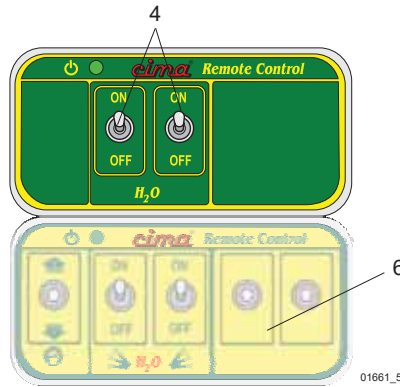
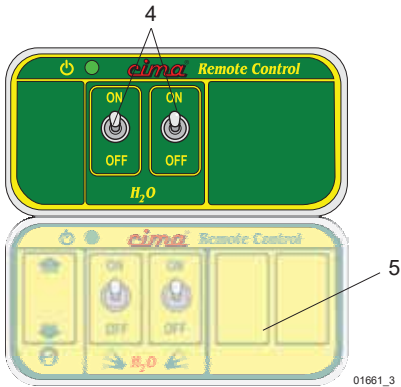

**THE FOLLOWING ACTIONS ARE NOT ALLOWED:**

- Transporting or lifting the sprayer with residual quantities of mixture in the tank for purposes differing from its destined usage.
- The transporting of people, animals or things.
- The trailing of vehicles or equipment.



Road transport must take place in the complete observance of road regulations in force in the Country where the machine is used.

- When the footprint of the sprayer exceeds that of the tractor, the specific notice sign for overhanging loads needs to be attached on the rear.
  - It is necessary to replicate the tractor's number plate and tail lights when these are covered by the machine.
- The operator is responsible for possible defaults due to the non observance of said regulations.

**• Lifting and transport of the sprayer**



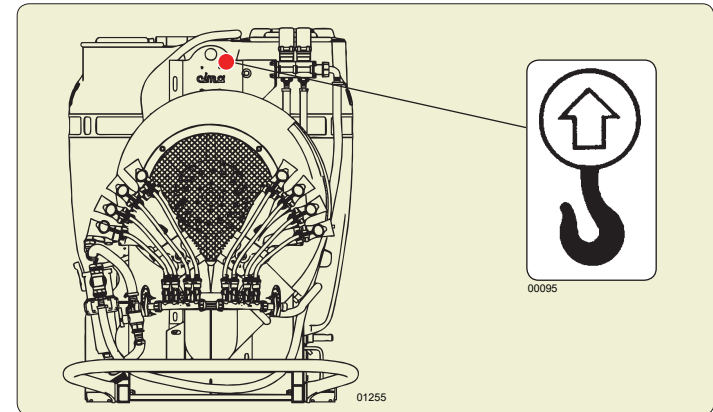

Before carrying out any operation it is essential to verify that no chemical mixture are left in the tank.

1. Check that the cables or chains used for the lifting are adequate for the weight to be lifted (machine – distribution devices - accessories).
2. Hook the machine through the specific support point indicated by the specific decal on the frame, checking all the parts involved in the operation.
3. Lift the machine, verifying that it is properly balanced, and, on those units equipped with either cables or hoisting chains, make sure that they DON'T get engaged with the plant-washing tank.
4. Position the sprayer on the transporting vehicle in perfectly stable conditions.



5. During transport the machine must be immobilised and fastened to the carrier by way of suitable strapping.

11 TANK AND HYDRAULIC CIRCUIT DRAINING 11

-   - Stop the tractor and remove the key from the control panel.
-  - Wear suitable protective clothing and accessories in order to avoid contamination by contact or inhalation of the mixture.
- Carry out the discharging in a suitable and properly geared area for the collection of the washing liquid.

EXECUTION:

1. Turn the tap lever (P2) in pos. "C" (drain closed).
2. Unscrew and remove the oil drain plug from the fitting (P16): to do only when the tap lever is in pos. "C" (drain closed).
- 3.a Turn the tap lever (P2) in pos. "D" (drain open).
- 3.b In order to drain also the spray-line rinsing tank (for versions on which it is foreseen) place the tap (P15) on pos. "a" (open).
4. Once the drain is completed, screw the oil drain plug and close the tap (P15) (lever on position "c") in case also the spray-line rinsing tank was drained (for versions on which it is foreseen).

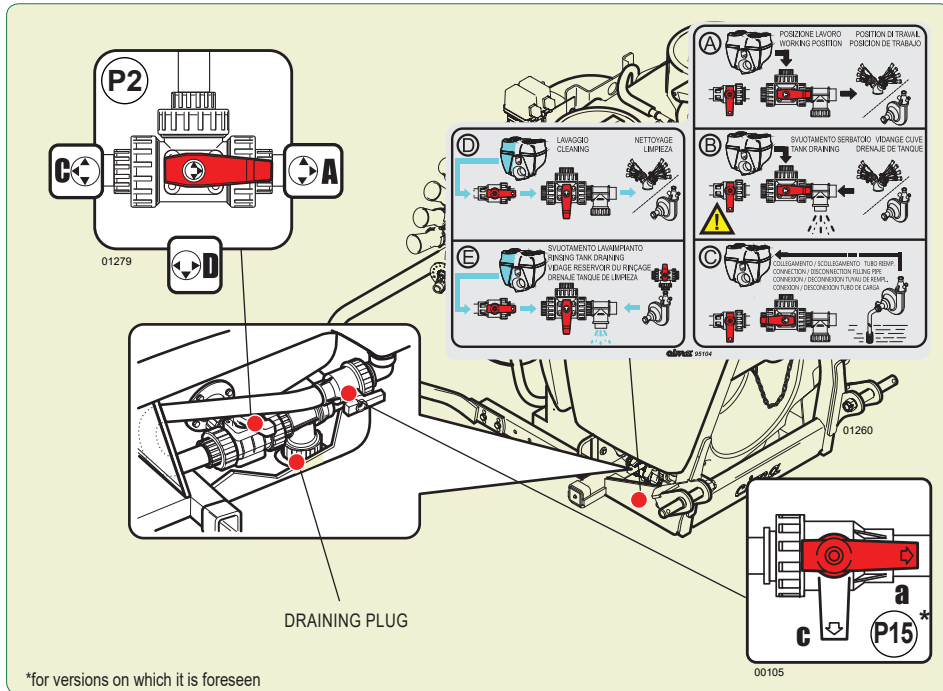

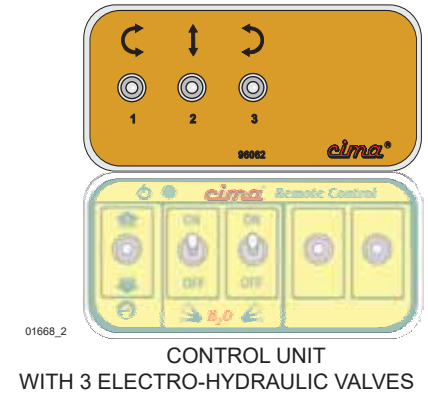

If the sprayer is equipped with a distribution device (sprayhead) fitted with hydraulic operation with 3 electro-hydraulic valves, in addition to the electrical control unit the machine will also be equipped with the respective control units (see manual "Distribution devices - Operation and maintenance instructions")

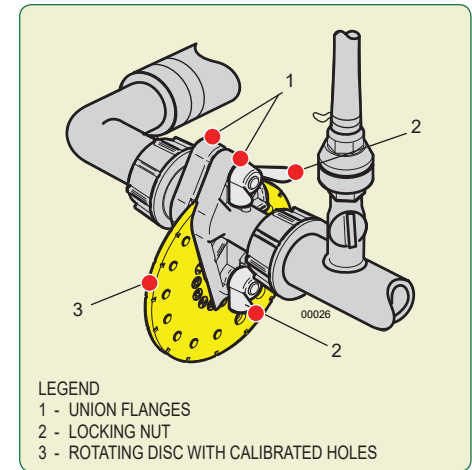

P11. CALIBRATION DISC (Patent n° 23238)

It selects the flow rates necessary to the treatment and is mounted on the distribution devices. It is made up of 2 flanges, held in position by two butterfly nuts, locking a disc with calibrated holes numbered from 1 to 15. A groove on the edge of the disc allows the exact positioning of the hole to be utilised. Its number must appear in the flange's semi-circular seat. The rotation of the disc is obtained by loosening the butterfly nuts by a few turns. After the operation is done, screw back carefully.



 Any faulty sealing condition of the hydraulic circuit causes an intermittent issuing of the sprayed material. It is necessary to carefully check the efficiency of the sealers and clamps, the tightening of the ring nuts and fittings and the good working condition of the piping.

P17. SPRAY-LINE RINSING TANK (for GOLD versions)

The tank is made of Polyethylene and is included in the main tank. It is provided with filling tank pipe union with D.355 mm screw lid. The pipe (T7) connects the tank to the sprayer hydraulic circuit through the 3 way tap (P2); the tap (P15) on the pipe connects or excludes the tank from the distribution circuit.

**P15. SPRAY-LINE RINSING TAP** (for GOLD versions)

The tap (P15) is connected on one side to the spray-line rinsing tank through pipe (T7) and on the other side to the centrifugal pump through the 3-way tap (P2). The plant washing tap allows the washing of the delivery circuit (tank not included) in any moment and independently from the loaded conditions of the tank, that is with mixture in the tank. The tap lever can be positioned as here following specified:

- a – OPEN (WASHING OF THE DELIVERY CIRCUIT)
- c – CLOSED

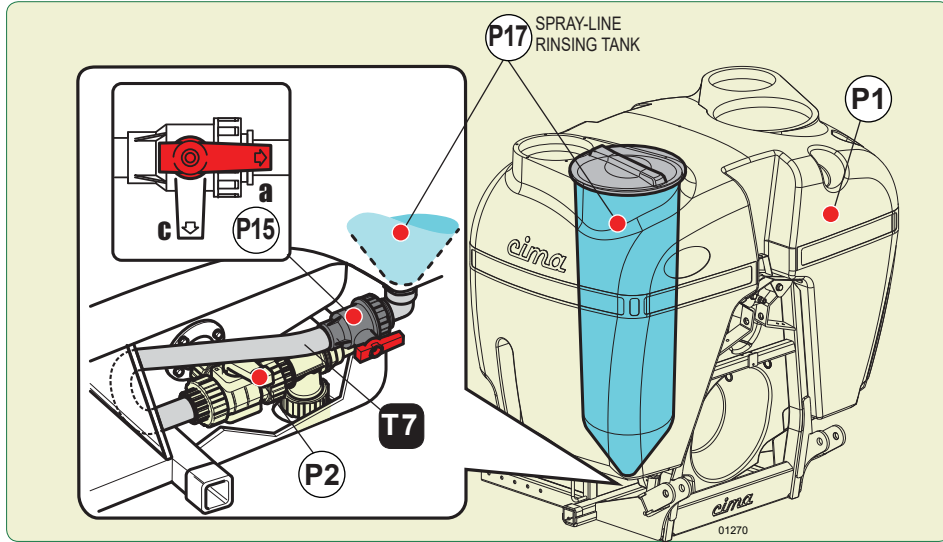

**4.4 TECHNICAL DATA**

**4.4.1 Sprayers dimensions and weights**

 On the identification plate, the full-load weight (PESO T.) of the machine is indicated, measured **WITHOUT** the distribution device, and **WITHOUT** the accessories possibly installed. In order to calculate the weight on the hoister in operative conditions (at full load), add to the weight indicated on the identification plate (PESO T.), the weight of the installed accessories, the weight of the distribution device which is used (see "Distribution devices – Use instructions" manual), and the 50% of the weight of the used cardan shaft (see the relevant specific manual).

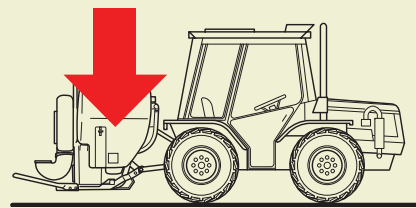

**TOTAL WEIGHT (PESO T.)**  
**+ SPRAYHEAD WEIGHT**  
**+ ACCESSORIES WEIGHT**  
**+ 50% CARDAN SHAFT WEIGHT**

---

**= WEIGHT ON THE TRACTOR**  
**THREE-POINT HOISTER**

01123



The machine must be stored in a secure or closed place, so as to prevent access to unauthorized personnel

**10.5.2 End of seasonal cycle**

- **The operator must:**
  - a. Take the utmost care in carrying out the operations envisaged at the end of the daily treatments: the cleaning of the hydraulic circuit and the main tank must be done at least twice. Check that no product residues are left in any part of the circuit.
  - b. Execute the necessary maintenance and lubrication operations (see paragraph 13.9), then let the atomizer operate for some minutes.



**THE PUMP MUST NEVER RUN DRY.**

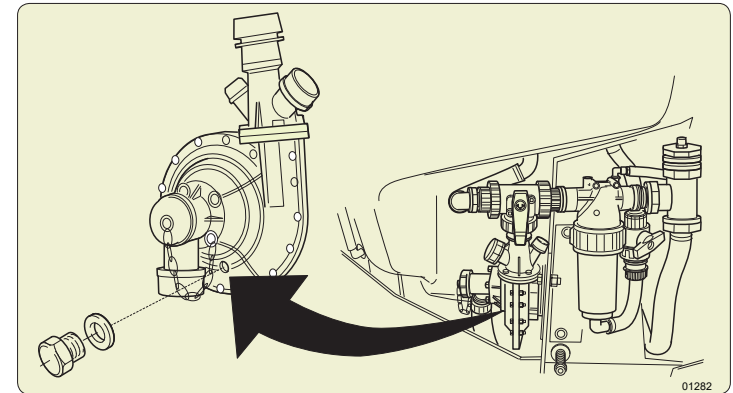

- c. Completely drain the hydraulic circuit, paying a special attention to the centrifugal pump; in order to completely drain the pump, remove the draining plug, which is mounted on the pump itself.



**Avoid using anti-freeze solutions.**

- d. Check the proper operation of all parts and of the machine structure. In case of faults being detected, request the intervention of one of our service points.
- e. Keep the machine on a plane surface with a suitable consistency, in a well ventilated place, sheltered from rain, icing and direct sun rays.



The machine must be stored in a secure or closed place, so as to prevent access to unauthorized personnel.

Or

11b. Spraying the rinsing water in the previously treated area. Discharge the remaining water of the tank and pipes (about 5,6 lt.), gathering it in a proper container to waste it following the country rules or use it again, putting in the tank, for a next treatment if thi will be suitable with the product tu use.

**if the machine HAS NOT a spray-line rinsing tank:**

a. Put about 15 lt.of clean water in the tank and spraying it in the already treated area.

b. Wash the tank:

1. Wash the main tank internally with a water jet employing a quantity of clean water equal to almost 10% of tank capacity, with the agitator while running
- 2a. Discharge the rinsing water in a proper area provided with a drain basin for the collection and take care of waste according to the country rules.

Or

2b. Spraying the rinsing water in the already treated area. Then, discharge the remainig water of the tank and pipes (about 5,6lt) gathering it in a proper container to waste it following the rules or use it again, putting it again in the tank, for a next treatment, if this will be suitable with the product to use.

If necessary repeat the washing procedure.

c. Wash the machine externally:



To wash it externally **DO NOT USE** high pressure washer (MAX 5 bar).

When each treatment has finished, it must wash the sprayer outside, in a proper area provided with a drain basin for collection and subsequently treatment of rinsing water.

These area are forbidden to unauthorized personnel, children and pets.

To outside sprayer rinsing, it is possible to use proper cleaning products and biodegradable to make the operation easier.

When the rinsing is finished, switch on the fan for few second (about 10) to remove residual water on carter and pipes which lead the flow to the sprayhead.









**The use of detergent products for the cleaning operations is allowed only in the observance of the regulations in force. For these, the operator must gather the relevant information from the specifically appointed bodies ruling on this subject.**

d. Check the efficiency of the distribution device (head) and the cleaning of the pulverising points (diffusers), possibly replacing them if found to be damaged.

e. Clean out the filter cartridge.

f. Keep the machine on a plane surface with a suitable consistency, in a ventilated place, sheltered from rain or sun: sunrays are the worst enemies of plastic and rubber parts.

		New Plus 42-45		New Plus 50			New Plus 55		
		lt. 300	lt. 400	lt. 300	lt. 400	lt. 600	lt. 300	lt. 400	lt. 600
	LENGHT	144 cm	144 cm	144 cm	144 cm	144 cm	144 cm	144 cm	144 cm
	WIDTH	96 cm	112 cm	96 cm	112 cm	137 cm	96 cm	112 cm	137 cm
	HEIGHT	119 cm	122 cm	119 cm	122 cm	127 cm	119 cm	122 cm	127 cm

		New Plus Gold 42-45		New Plus Gold 50			New Plus Gold 55		
		lt. 300	lt. 400	lt. 300	lt. 400	lt. 600	lt. 300	lt. 400	lt. 600
	LENGHT	144 cm	144 cm	144 cm	144 cm	144 cm	144 cm	144 cm	144 cm
	WIDTH	96 cm	112 cm	96 cm	112 cm	137 cm	96 cm	112 cm	137 cm
	HEIGHT	127 cm	130 cm	127 cm	130 cm	135 cm	127 cm	130 cm	135 cm

#### 4.4.2 Weight of accessories



The accessories and related data listed in this table are up to date at the time of publication of the manual. All products and accessories not included and their updated weights are available on the table (Pesi- Weights.pdf) in the ‘ restricted area ‘ in the website [www.cima.it](http://www.cima.it), direct link (<http://drawings.cima.it/search?Query=pesi-weights.pdf>).

Description	Model	Part Number	Peso (kg)
Pair of wheels with hubs and mud scrapers	New Plus 42/45 New Plus 50/55 400 lt.	T.CPP.RT.01	42,50
	New Plus 50/55 600 lt.	T.CPP.RT.02	46,50
Electrical pressure reg.valve with remote control	New Plus: all models	D.V.P01	-
4 electrovalves assembly	New Plus: 42/45/50/55	D.4E.P11	6,00
4 electrovalves assembly (E.P.A. versions)	New Plus 45	D.4E.P11E	-
Electrical pressure reg.valve + Electrical movement TC/TCS. 2M2C - 4M2C	New Plus 45/50	D.V.TC2.P01	-
	New Plus 55	D.V.TC2.P02	-

Description	Model	Part Number	Peso (kg)
Electrical pressure reg.valve + Electrical movement TC/TCS. 2M4C - 4M4C	New Plus 45/50/55	D.V.TC4.P01	-
Electrical pressure reg.valve + Electrical movement TCF. 2M4C - 4M4C	New Plus 45/50/55	D.V.TCF.P01	--
Electrical pressure reg.valve + Electrical movement TCI/TCIS. 2M4C - 4M4C	New Plus 50/55	D.V.TCI.P01	-
Electrical movement 2 upper cannons TC sprayheads	New Plus 45/50	D.TC2.P01	2,00
	New Plus 55	D.TC2.P02	1,50
Electrical movement 4 upper cannons TC sprayheads	New Plus: all models	D.TC4.P01	2,00
Electrical movement upper diffusers	New Plus 50/55	D.TCI.P01	2,5
Free wheel (France)	New Plus: all models	DIFF.R.LIB.	1,90
E.P.A. Delivery Proportional Advancement Kit	New Plus 42-45	E.04.P01	-
	New Plus 50	E.06.P01	-
E.P.A. + Electrical movement TC/TCS. 2M2C - 4M2C	New Plus 45	E.04.TC2.P01	-
	New Plus 50/55	E.06.TC2.P01	-
E.P.A. + Electrical movement TC/TCS. 2M4C - 4M4C	New Plus 45	E.04.TC4.P01	-
	New Plus 50/55	E.06.TC4.P01	-
E.P.A. + Electrical movement TCF. 2M4C - 4M4C	New Plus 45	E.04.TCF.P01	-
	New Plus 50/55	E.06.TCF.P01	-
E.P.A. + Electrical movement TCI/TCIS. 2M4C - 4M4C	New Plus 50/55	E.06.TCI.P01	-
Container washing device	New Plus: all models	KIT.LAV.BOX	0,20
Manual swivelling device D.175mm	New Plus 42/45	T.GIR.M.175P.13	9,00
Hydraulic swivelling device D.175mm	New Plus 42/45	T.GIR.I.175P.13	13,70
Manual swivelling device D.250mm	New Plus 55	T.GIR.M.250P.12	18,00
Hydraulic swivelling device D.250mm	New Plus 55	T.GIR.I.250P.12	28,00
Filling pipe with foot valve and filter	New Plus: tutti	TUBAZ.RIEMP	2,60
Extension D.175 x 200 mm	New Plus 42/45/50	X02.186.000	2,10
Extension D.175 x 400 mm	New Plus 42/45/50	X02.187.000	3,45
Extension D.175 x 600 mm	New Plus 42/45/50	X02.188.000	4,75
Extension D.175 x 800 mm	New Plus 42/45/50	X02.189.000	6,00
Extension D.250 x 200 mm	New Plus 55	X21.100.020	3,40
Extension D.250 x 400 mm	New Plus 55	X21.100.040	5,30
Extension D.250 x 600 mm	New Plus 55	X21.100.060	7,15
Extension D.250 x 800 mm	New Plus 55	X21.100.080	9,00
Collar for D.175mm. extensions and elbows	New Plus 42/45/50	X05.616.000	0,40
Collar for D.250mm. extensions and elbows	New Plus 55	X05.813.000	0,95

## 10.5 END OF TREATMENT - STORAGE

### 10.5.1 Daily

The operator must:

**if the machine is equipped with unit-washing tank:**

a. carry out the hydraulic circuit washing process (see paragraph 10.4) spraying on the piece of ground treated yet. Attention: to make to spray the sprayer for around 5 sec..

b. Wash the inside of the tank:

1. Disengage the fan (for the version where foreseen): see point 8.1.a.
2. Close the taps of the 2-way distributor:
  - if electrical, position the latch switches (E10).on "OFF"
  - if manual (P9), set the levers in the horizontal position;
3. Turn the tap lever (P6) in pos. "B" .
4. Open the cock (P15) and position the lever of tap (P2) to the "D" position.
5. Engage the drive outlet (PTO) and take it to a speed of 540 RPM



**Use ONLY the PTO at 540 rpm. Engage the PTO with the engine of the tractor at low speed and with maximum modularity, obtaining soft and progressive graft and avoiding abrupt starts of the cardan shaft.**

6. Open the tap (P12), lever on "a".
7. Rinse the tank until the water in the spray-line rinsing tank is totally run out, if needed wash the internal of the tank with a jet of clean water as expected for the machine without circuit-washer.
8. Disengage the drive outlet (PTO).
9. Close the tap (P12), lever on "c".
10. Close the cock (P15) and re-position the lever of tap (P2) to the "A - WORK" position.
- 11a. Discharge the rinsing water in area with a drain basin and arrange the waste following the country rules.

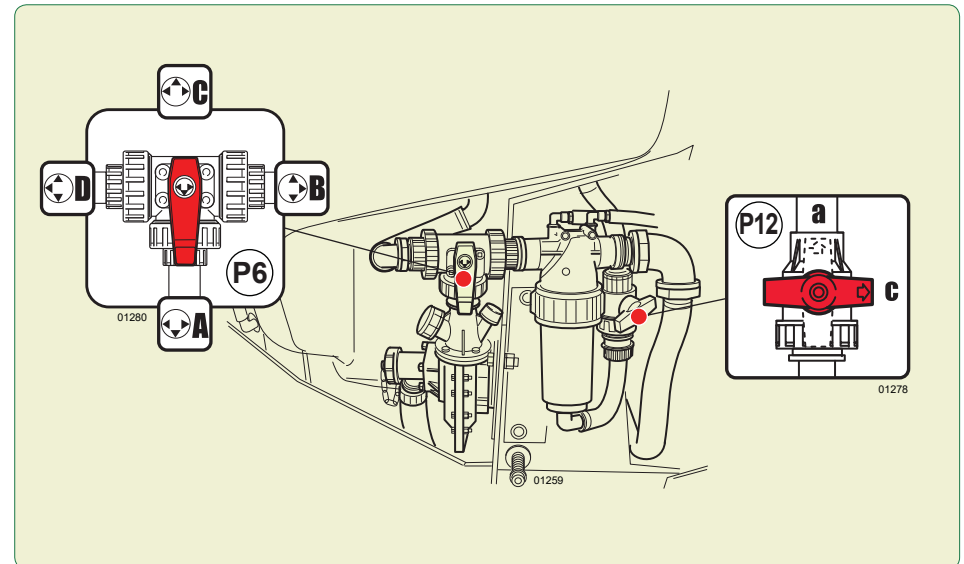



CAUTION: THE PUMP MUST NEVER RUN DRY.

d. Open the electrovalves E9 by taking the switches of the control electric switchboard on ON (or taps of the manual distributor P9); make the atomizer work spraying on the piece of ground not treated yet, for a sufficient time to test the leakage of clean water from the sprayhead.

That easy procedure allows to eliminate every fuel mixture residual from all the hydraulic circuit components, so assuring in first place the accurate cleaning and the consequent efficiency of the calibrated holes of the rotary disc regulators.

e. Disengage the PTO.

f. Close the cock (P15) and re-position the lever of taps (P2) and (P6) to the "A" position (WORKING POSITION).

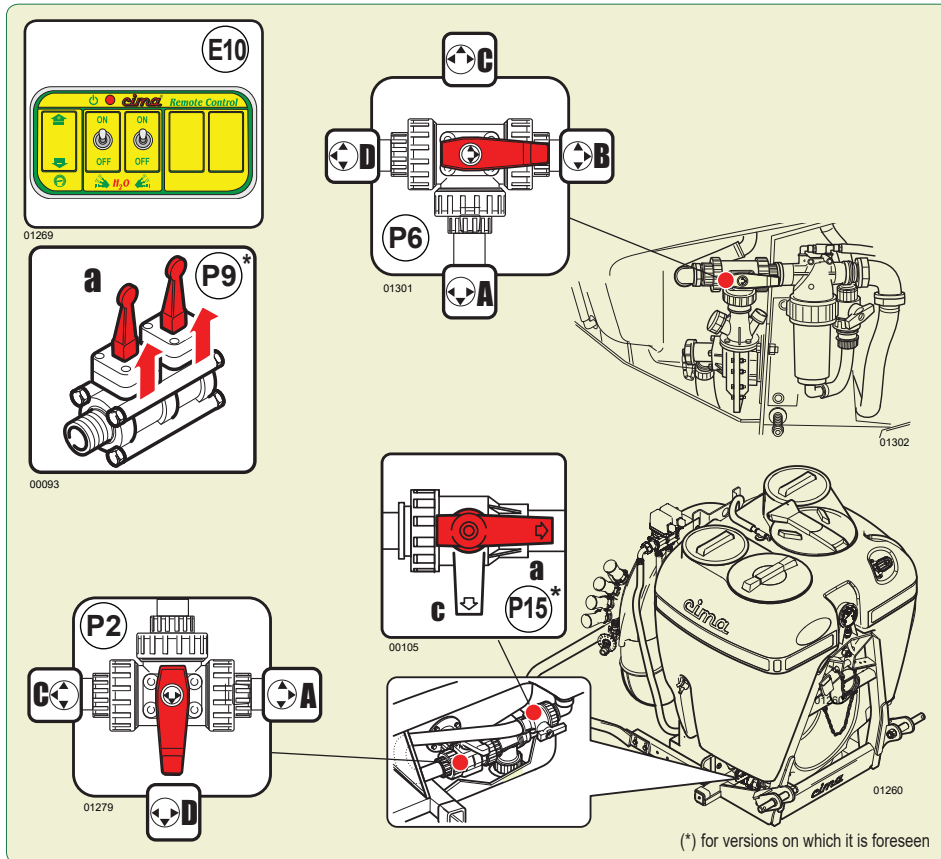

### 4.4.3 Centrifugal pump CD32

Model C.I.M.A. CD32 - Grid/filter on suction - Drain plug - Filler for the connection of the filling pipe, with plug with chain.

Activated with trapezoid belt driven by the pulley mounted on the fan shaft.

Technical data printed on the body of the pump:

- Speed .....4000 RPM New Plus 42
- Maximum Flow rate (operating conditions) ..... 120 litres/min. New Plus 42
- Speed .....4250 RPM New Plus 45-50-50S-55S-E
- Maximum Flow rate (operating conditions) ..... 140 litres/min. New Plus 45-50-50S-55S-E
- Pump's suction filter ..... 7 mm
- Maximum pressure ..... 4,5 Kg/cm<sup>2</sup>
- Power absorbed .....kW 2,1

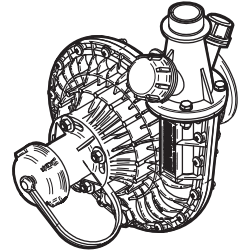

The performance specified is obtained with the drive outlet (PTO) at 540 RPM. For a good result of the treatments this condition MUST ALWAYS BE OBSERVED during the machine's operation. Utilisation is permitted with speed rates ranging between 500 and 620 RPM.

### 4.4.4 Filters

- Filter (P7) ..... 250 litres/min - 32 mesh
- Pump's suction filter ..... 7 mm
- Tank filling filters ..... 18 mesh
- Filling pipe filter (optional) ..... 16 mesh

### 4.4.5 Tanks

Sprayer model	Main tank volume (lt.)	Rinsing tank volume (lt.)	Main tank residual volume (lt.)
New Plus: 42-45	300	32	5,6
New Plus: all models	400	43,5	5,6
New Plus: 50-55	600	63,5	5,6

### 4.4.6 Fans

	New Plus					
	42	45	50	55	55 Super	55 Extra
Diameter (mm)	450	450	500	550	550	550
Speed (RPM)	4000	4360	3925	3390	3625	3840

### 5.1 HITCHING TO THE TRACTOR



Check that the tractor's "permissible carried weight" and the "rear overhang allowed" are compatible with the weight and dimensions of the fully loaded sprayer and complete with equipment mounted for the treatment (see Paragraphs "3.1" - "4.4.1" and the attached documentation).



The tractor's power take-off (PTO), under all utilisation conditions, must provide a power exceeding that absorbed by the sprayer..

Pairing suggested for tractors of at least :	New Plus					
	42	45	50	55	55 Super	55 Extra
CV - SAE	25	45	65	70	80	90
kW	18	33	48	52	58	66







The hitching has to be carried out on a plane surface with a suitable consistency, after having checked that all the people not charged with the operation moved away, as well as the children and the animals possibly present.



On-road use is permitted only in accordance with the rules in force in the country of use, without having loaded chemicals in the tank.

EXECUTION::

- Loosen the chains of the lifter arms.
- Start the tractor and take the lifter's arms to the level of the machine's pins.
- 

**Stop the tractor and remove the key from the control panel.**
- Insert the toggle joints on the machine's pegs, locking them with the clip pins.
- Hook the 3<sup>rd</sup>-point rod from the tractor to the machine and securing it with the peg and the clip pin.
- Screw the rod to set it into tension.
- Start the tractor and hoist the sprayer until the 2 PTO are the same height.
- 

**Stop the tractor, remove the key from the control panel and make sure that no one approaches the hydraulic controls of the lifter. NEVER OPERATE OR STAND BENEATH THE MACHINE OR IN THE AREA THAT COULD BE INVOLVED IN ITS SUDDEN LOWERING.**
- By acting on the 3<sup>rd</sup>-point rod, vertically align the sprayer. N.B.: block the 3<sup>rd</sup>-point rod with the specific lock ring..
- Block the coupling by tightening the chains of the hoister arms.



When the operation is completed the 2 drive outlets (PTO) must be positioned on the same axis, both in vertical and horizontal direction.

The operator must:

- Shake the mixture** in the tank before starting the treatment, re-circulating it completely for as long as it takes to make it homogeneous.
- Check** the orientation of the distributors (hands and/or cannons) of the distribution device (sprayhead) in relation to the dimensions, the shape and the thickness of the vegetation to be treated.
- Continue to shake the mixture until the treatment is resumed should the intervention momentarily be interrupted. If the utilisation is to be deferred, check that the filter cartridge is clean before resuming and **agitate the mixture** that has remained in the tank.
- Ensure that the hand wash supplementary tank is filled with clean water after each filling operation.
- Make use of individual protections identical to those envisaged for the preparation of mixtures if the tractor is not equipped with a pressurised cabin with aeration filters.
- Wash immediately all the elements that might have become contaminated during the treatment, promptly remove the polluted garments and **interrupt the work if these cannot be immediately replaced.**
- Keep to the preliminary operations already indicated (10.1.c), in case of wind conditions prevailing.
- During the breaks, stop the engine, remove the key from the grape harvester's control panel.
- Pay particular attention to the treatment when close to boundaries and in proximity of dwellings, waterways, roads or public-usage paths.

### 10.4 PROCEDURE TO WASH THE HYDRAULIC CIRCUIT

(sprayhead-pump)



In case of machines equipped with unit-washing tank, every time it is necessary to suspend the treatment, it is possible to carry out the hydraulic circuit washing process, independently on the loading conditions, i.e., also when the tank is still containing some product mixture, so avoiding any possible clogging and assuring the perfect efficiency of the machine when the treatment is carried on again.

In case of prolonged idle periods, it is recommended to keep the mixture agitated (see Chapter 9)

In order to carry out the hydraulic circuit washing process, follow the instructions here specified:

- Position the faucet (P6) on position "B".
- Position the faucet (P2) on position "D" and open the tap (P15); in that way the clean water contained inside the unit-washing tank is sucked by the pump (P4) and gets into the hydraulic circuit.
- Engage the PTO and take it to the correct distribution condition (540 RPM - see paragraph 4.4.3).



- h. Wash the equipment and tools utilised in the preparation and place them in the chemical products storage area.
- i. **Always** leave the area assigned to the loading and preparation of the mixtures in such condition as to avoid **any** possibility of contamination to persons or animals or of pollution to the environment.
- l. With indelible pen put the name of the product used for the treatment (or of several names) on the decal 10x10 cm and put it on the provided support on the machine.

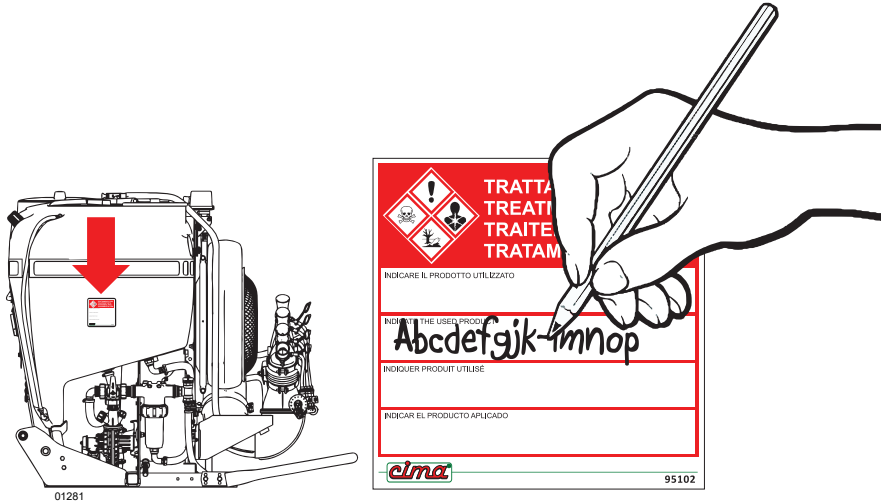

- m. If necessary, mark the field or the area of machine passes in order to provide a guide for the treatment and avoid missing or double-treating coverage areas.

- AT THE END OF THE OPERATIONS NECESSARY FOR CARRYING OUT THE INTERVENTION, THE LOCATION-STORAGE AREAS MUST BE LEFT IN THE CONDITION REQUIRED FOR THE CARRYING OUT OF THEIR PREVENTION AND PROTECTION FUNCTIONS.**
- BEFORE STARTING THE GRAPE HARVESTER, KEEP AWAY PERSONS OR ANIMALS AND NEVER LEAVE IT UNATTENDED DURING THE PREPARATION OPERATION.**

### 10.3 THE TREATMENT

- IT IS ADVISABLE TO BEGIN TREATMENT AT THE HEADLANDS.**

- WHEN THE TREATMENT IS OVER, OR IF THE SAME HAS TO BE TEMPORARILY INTERRUPTED, ALWAYS LET THE FAN STILL OPERATE FOR APPROXIMATELY 10 SEC. AFTER CUTTING-OUT THE POWER SUPPLY (either electrical distributor E9 or manual distributor P9), IN ORDER TO FULLY ELIMINATE THE PRODUCT MIXTURE FROM THE DISTRIBUTING DEVICES, SO PREVENTING ANY POSSIBLE ANOMALOUS DRIPPING FROM TAKING PLACE.**

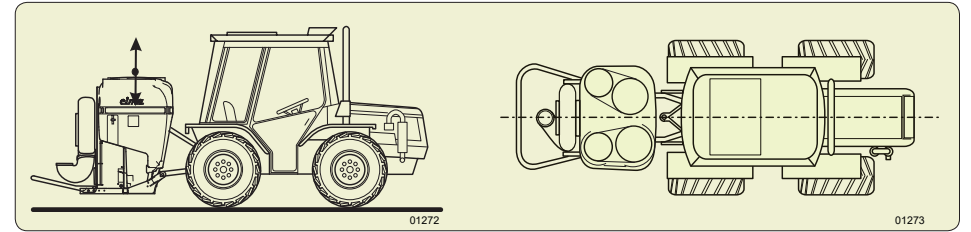

### 5.2 MOUNTING OF THE TRANSMISSION SHAFT

- The mounting, disassembling or possible other interventions on the transmission shaft must be carried out with the engine switched off and with the starter key removed from the tractor's control panel.**

- Use transmission shafts with CE certification. Observe the regulations contained in the use and maintenance booklet provided by the shaft manufacturer.**

- The cardan transmission shaft must work with the 2 COAXIAL drive outlets (PTO) or, should this not be possible, with the PARALLEL axles. In this case the angle of the joint MUST NOT EXCEED 15°.**

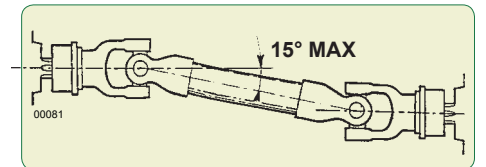

### Definition of the transmission shaft length

Set the 2 drive outlets (PTO) perfectly on the same axis and measure the distance "D" between their grooves. Length "L" of the cardan transmission shaft (refer to the picture) to be deployed, measured between the 2 stopping pawls and with joint closed, must be 40+50 mm lesser than distance "D".

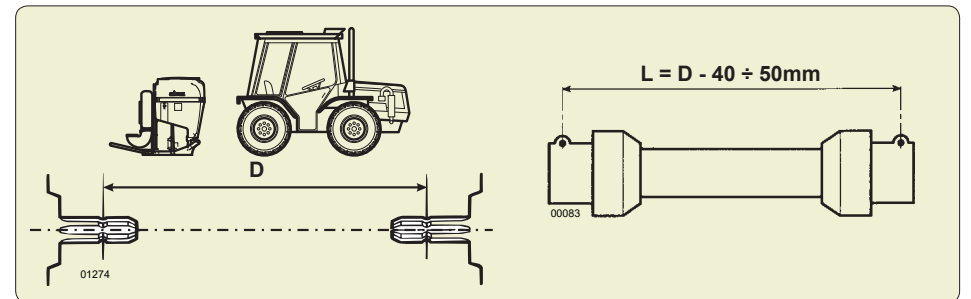

- Using the cardan shaft too much short can cause the breach of it, with serious damages to the sprayer and/or to the tractor, and dangerous for the persons.**

- Using the cardan shaft too much long can cause a push on the two PTO, that it can cause huge mechanical damages both to the tractor and to the sprayer.**

### 5.3 INSTALLATION OF REMOTE CONTROLS

#### 5.3.1 Electrical control panel - E10

1. Fix the fastening bracket near to the driver (if not already available on the tractor).
2. Insert the bayonet support of the control panel in the securing clamp and position it so that the controls are fully visible and accessible during use.
3. Connect the distribution piping (T5) to the hydraulic circuit of the distribution device (head) mounted on the machine (follow the instructions of the specific "use and maintenance" booklet which is supplied with it).
4. Connect the feeding pipe (T4) with the electrical distributor (E9).
5. Connect the power supply cable "W1" plugging it in the socket of the tractor..



Position the electrical cables W1 and W2 in such a way as to avoid risking their being wrenched off during treatments. If necessary, use some securing clamps. A sudden interruption of power will lock the 2 electrovalves of the electrovalves assembly "E9". Should this fault take place when they are in the open position, it is necessary to:

- Stop the tractor and remove the key from the control panel.
- Position the cock (P6) to "D".
- Restore the electric current.

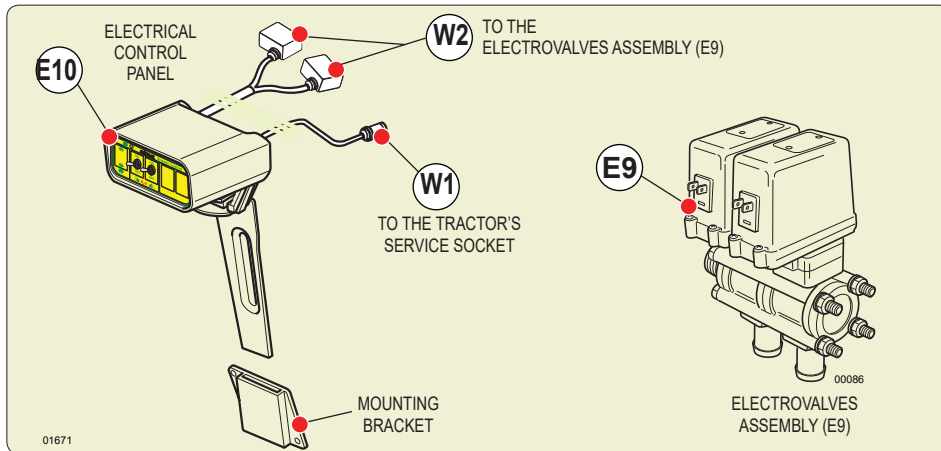

#### IN CASE OF A PIPE BURST:

1. Stop the tractor and remove the key from the control panel.
2. Close the electrovalves (E9), the switches on the control panel (E10) must be on OFF.
3. Place the lever of the 3-way tap (P6) in position "d".
4. Replace the broken pipe (for the elimination of these parts, please follow the current regulations).

- e. Carefully calculate the exact quantity of the product necessary for the treatment and establish the volume of water to be used for the intervention.
- f. Check that the product is available in a quantity sufficient to complete the intervention.
- g. Read the product's utilisation instructions carefully, in order to ascertain the usage conditions, the correct dosage and the expiration dates.
- h. Make sure of the parameters necessary to the adjustments of the machine and determine the exact dose of product to be applied to every loading. **Follow the instructions of the publication titled "The low volume - Instructions for sprayers adjustment" as well as those contained in the use and maintenance book-let of the distribution device.**

### 10.2 - PREPARATORY OPERATIONS TO TREATMENT



ITHE FILLING MUST BE CARRIED OUT WITH THE MACHINE ON A FLAT SURFACE. BEFORE THE OPERATION, IN THE ALLOCATED AREA, THE DOSES OR MIXTURES TO BE POURED IN THE TANK MUST BE MADE READY.

Before starting the filling cycle, check:

- THE LEVEL OF THE OIL OF THE FAN SHAFT SUPPORT;
- THE CLEANING OF THE FILTER CARTRIDGE (P7);
- THE EFFICIENCY OF THE DISTRIBUTION DEVICE (HEAD).
- THE CONDITIONS OF THE TANK LEVEL INDICATOR.

#### • The operator must:

- a. Wear adequate protective clothing and accessories such as overalls, waterproof suits, gloves, glasses and masks to shield him from contamination by inhalation or contact with the products handled.



- Anti-dust masks don't offer any protection against toxic vapours.
- Avoid wearing loose clothes that might entangle with moving parts.

- b. With the parameters defined during the preliminary operations, carry out the adjustments of the sprayer.
- c. Prepare the mixtures in a well ventilated area. When in the open, the presence of wind increases the danger of contamination.
- d. Precisely weigh the previously calculated doses of products to be mixed at every filling operation.
- e. Avoid handling products close to open flames, embers, incandescent bodies or in the presence of flammable substances.
- f. In order to obtain the correct volume dosage of agro-chemicals and fertiliser mixtures, the fertiliser must be first diluted.
- g. Wash and rinse the just emptied product containers with clean water – collect the washing water and pour it in the tank before carrying out the filling – place the empty packaging in the specific container or in the collection area.

The **hydraulic** and the **pneumatic** circuits mounted inside the tank, allow to realize a **double agitation system**: with the pump water and with the fan air, **at the same time**. The pneumatic circuit can be excluded, when the products used have a quite strong foaming effect, by closing the pneumatic agitator cock. When that cock is opened again, check that some air outlet holes aren't obstructed.



It is advised however to also use always the pneumatic agitator, adding to the mixture, if necessary, a antifoam product.

This operation is of main importance, in order to get a uniform distribution of the active principle on the whole vegetative surface to be treated. Should the activity need to be interrupted during a treatment with the sprayer, **keep the agitator activated until the treatment is resumed**.



Before starting the treatment, or return to work after a break, it is essential to agitate the mixture in the tank, re-circulating it completely for as long as it takes to make it homogeneous.



The agitation can be carried out with the manual pressure regulator (P5) or electric (E5), in any position. The tap of the pneumatic regulator has to be open.

**THE MIXTURE AGITATION HAS TO BE CARRIED OUT WITH THE POWER TAKEOFF RUNNING AT A RATE OF AT LEAST 500 RPM.**



Before using the atomizer fill the circuit-washer tank (if provided) and the hand-washer tank with clean water.

### 10.1 PRELIMINARY OPERATIONS TO TREATMENT

- The operator must:
  - a. Ascertain that the condition of the crops, the progress of the disease or the need for its prevention actually justify the treatment to be applied;
  - b. Be aware of the meteorological conditions forecast for all the time necessary for carrying out the treatment;
  - c. If possible, avoid carrying out the spraying in strong wind conditions or when one detects that the sprayed mixture disperses away from the target crop (drifting). It is advisable to suspend the treatment when the wind speed exceeds 3 m/s (10 km/hour). Should it be imperative to operate anyway, the following suggestions are made:
    - reduce the distance of the target from the spraying points, even if detrimental to the quality of the spraying
    - increase the dimension of the droplets, suitably adjusting the machine.
  - d. Check that multiple-product mixtures be physically, chemically and biologically compatible amongst themselves; if need be, obtain the necessary information from the products' sales representative.

### 5.3.2 Manual 2-tap distributor - P9 (for versions on which it is foreseen)

1. Mount the securing bracket on the tractor within the driver's reach (if this is not already present on the tractor).
2. Insert the distributor's bayonet support in the securing bracket and position it so that the controls are fully visible and accessible during use.
3. Connect the feeding pipe (T4)
4. Connect the distribution piping (T5) to the hydraulic circuit of the distribution device (head) mounted on the machine (follow the instructions of the specific "use and maintenance" book-let which is supplied with it)..

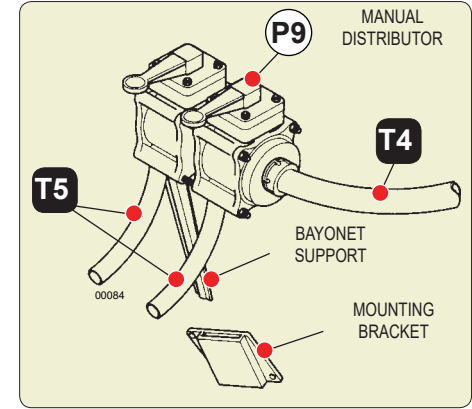

Position the distribution piping (T5) and feed piping (T4) so as to avoid the risk of suffering damage or breakage during spraying. IT MAY BE NEEDED TO SHORTEN THE PIPES.

IN CASE OF A PIPE BURST:

1. Stop the tractor and remove the key from the control panel.
2. Close the 2 taps of distributor (P9).
3. Move the 3-way cock (P6) lever to position "D".
4. Repair or replace the broken pipes (for the elimination of these parts, please follow the current regulations).

### 5.3.3 E.P.A. Control Unit (for versions on which it is foreseen)



Act in a similar way as indicated for installing the electric control panel (E10) (see Paragraph 5.3.1.)



Position the electric cables in such a way to prevent them from getting torn during the treatment.

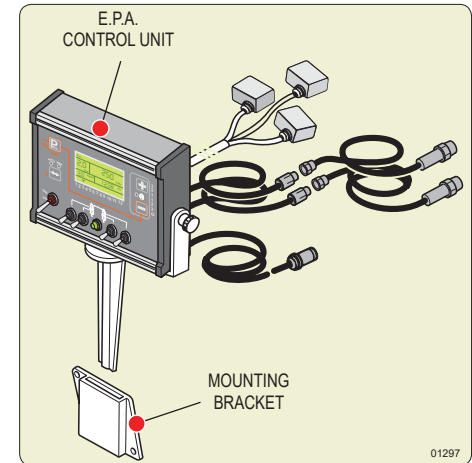



Every distribution device is supplied with its own USE AND MAINTENANCE booklet that is, or will have to be, attached to this publication and will constitute one of its integral parts.

The manual "Distribution devices - Operation and maintenance instructions" illustrates the wide range of distribution devices (sprayheads) that can be used with each sprayer and also contains assembly instructions; if necessary, a specific assembly diagram is provided with the "Spare parts catalogue" of each sprayhead. All usable distribution devices are easy to orient and adjust to guarantee perfect coverage, in compliance with the actual needs of the area being treated.

**Simple sprayheads**

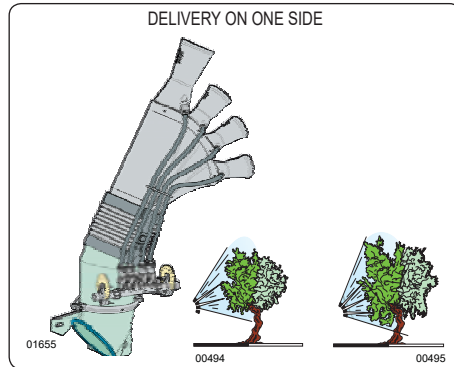
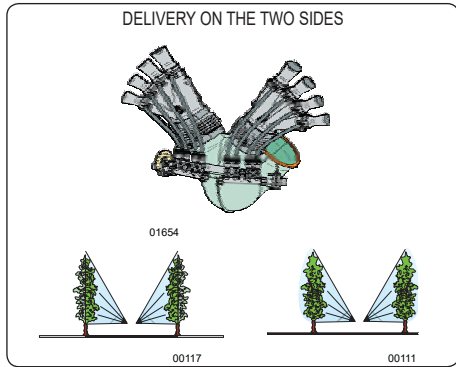

**Combined sprayheads**

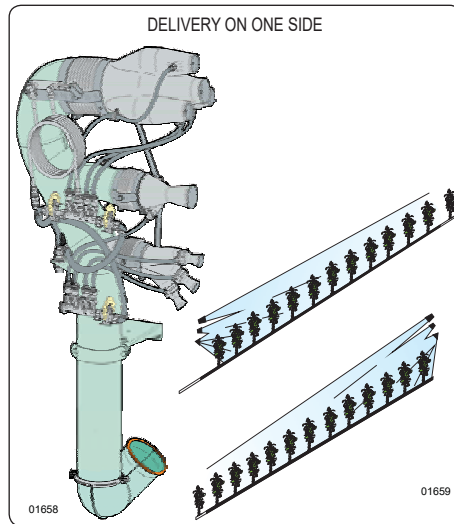
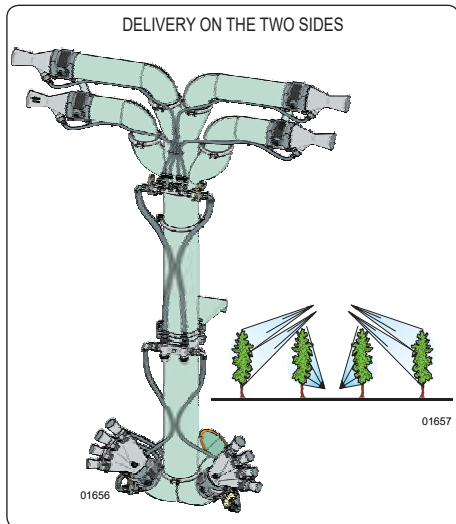

16. Start the tractor, always observing the safety norms.
17. Lift the unit. Engage the Power Takeoff and set it up to a running rate of **at least 500 RPM**, in order to carry out a further agitation.
18. CARRY OUT THE TREATMENT (See the paragraph 10.3).

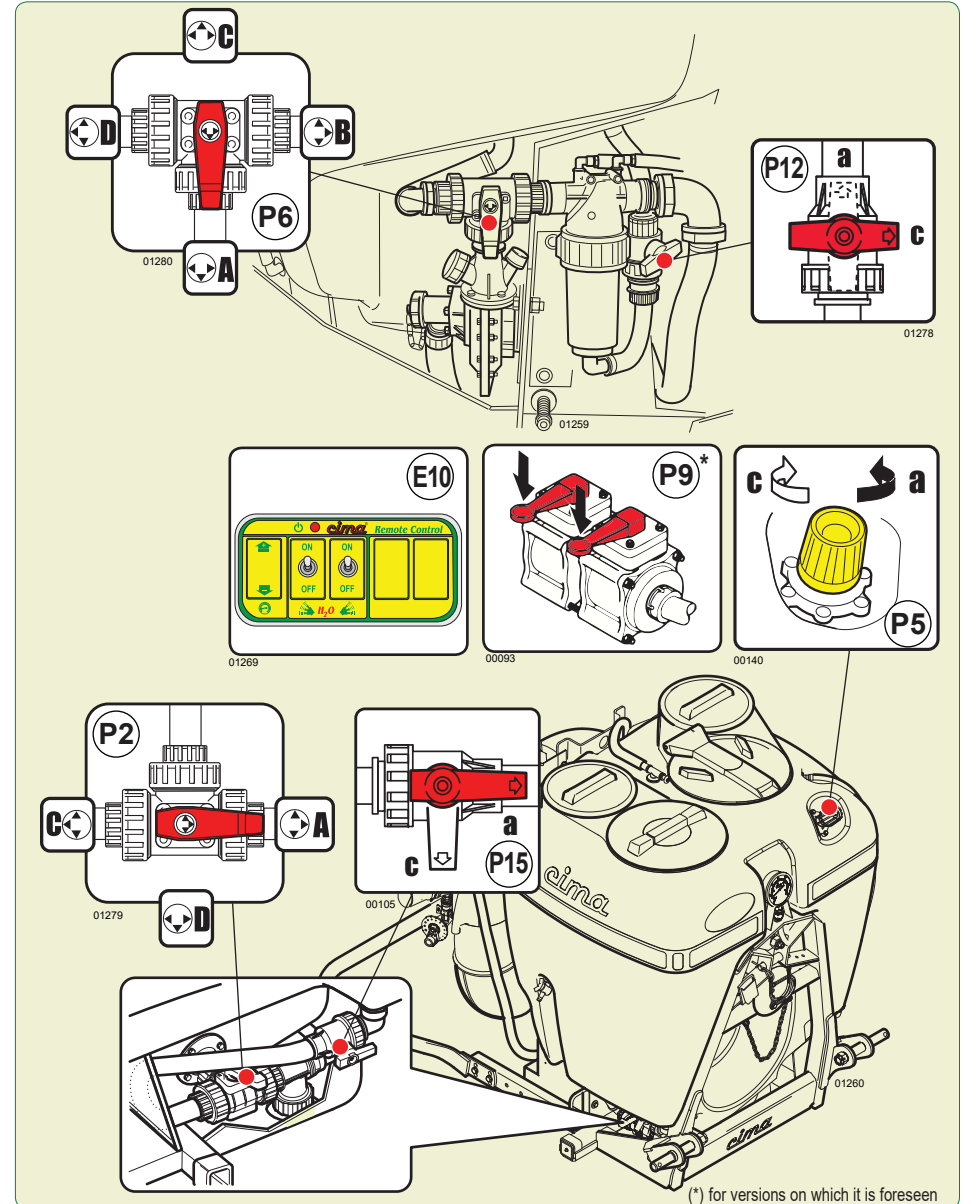

4. Check that the cock (P15) is closed and set the lever of taps (P2) and (P6) to the "C" position (CONNECTION/DISCONNECTION FILLING PIPE).
5. Connect the filling pipe to the pump.
6. Re-position the lever of taps (P2) and (P6) to the "A" position (WORKING POSITION).
7. Immerse the filter with the bottom-drawing valve in the water to be loaded.



**The filter must always be below the level of the water to be loaded. The piping must never be above the pump's suction point and must never be excessively bent in the vertical direction.**

8. Through the secondary filler BS, pour approximately 15~20 litres of water into the tank: the quantity must be sufficient to FILL the piping and ACTIVATE the pump to start the recycle.
9. Activate the power take off (PTO) and take it to a rotation speed of **at least 500 RPM**.



**Use ONLY the PTO at 540 RPM. Engage the PTO with the engine of the tractor at low speed and with maximum modularity, obtaining soft and progressive graft and avoiding abrupt starts of the cardan shaft.**

10. When the pump has started the circulation of the water poured, close tap (P2) (lever on "c") to start up the filling.

**11a. WITH MEDICINAL MIXTURES OR LIQUID PRODUCTS (WITHOUT MIXER DEVICE).**

- 11a1. Pour the mixture of medicinal envisaged through the main filler (BP), together with the water used to wash the canister of product and the tools used in the preparation.
- 11a2. Close the main filler (BP) of the tank.
- 11a3. After completing the filling, disengage the PTO
- 11a4. Position the lever of taps (P2) and (P6) to the "C" position (CONNECTION/DISCONNECTION FILLING PIPE)
- 11a5. Disconnect the filling pipe and remount the screw plug on the pump.
- 11a6. Open the faucet (P2) by putting the lever on position "A - WORKING POSITION".
- 11a7. Open the faucet (P6) by putting the lever on position "A - WORKING POSITION".

**11b. WITH POWDER PRODUCTS: UTILISING THE MIXTURE DEVICE**

- 11b1. Pour the dose of medicinal in powder form foreseen for each loading into the main filler (BP) of the tank.
- 11b2. Close the main filler (BP) of the tank.
- 11b3. Open the cock (P12) (lever on "a").
- 11b4. Wait for the filling to be completed.
- 11b5. Close the cock (P12) (lever on "c").
- 11b6. Disengage the power take off (PTO).
- 11b7. Position the lever of taps (P2) and (P6) to the "C" position (CONNECTION/DISCONNECTION FILLING PIPE)
- 11b8. Disconnect the filling pipe and remount the screw plug on the pump.
- 11b9. Open the faucet (P2) by putting the lever on position "A - WORKING POSITION".
- 11b10. Open the faucet (P6) by putting the lever on position "A - WORKING POSITION".
12. Engage the Power Takeoff and move to the treatment place, keeping the Power Takeoff running rate **at least 500 RPM during all the way**.

**IN THE AREA OF THE TREATMENT**

13. Disengage the power take off (PTO) and rest the machine on the ground.
14.  **STOP THE TRACTOR AND REMOVE THE KEY FROM THE CONTROL PANEL.**
15. Make sure that the fan is stopped. Hook the fan to the servo amplifier as indicated at point 8.1.b.

**6.1 POSITIONING OF FAN CASING**

The fan's air outlet must be positioned according to the distribution device to be mounted and the modality in which it is to be utilised. The operation is possible since the fan's casing can be rotated on its axis up to 360°.

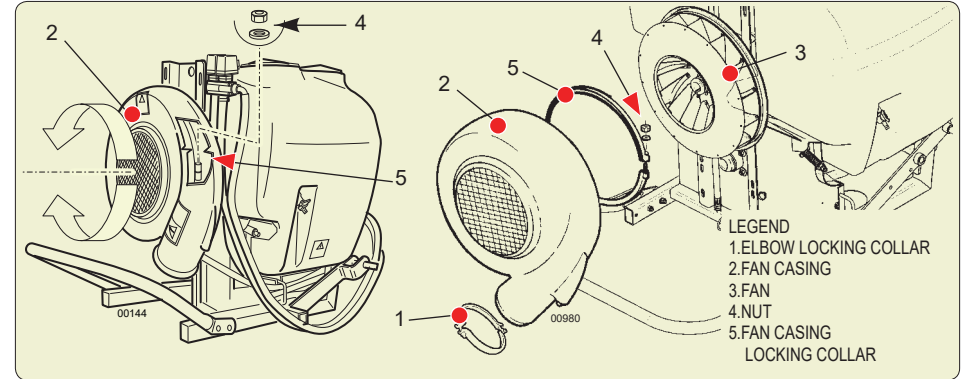

**POSITIONING OF THE CASING:**

1. Position the sprayer on the ground if it is mounted on the tractor.



**Switch off the tractor and remove the key from the control panel.**

2. By undoing the locking nut, loosen the collar which supports and locks the casing to the frame, located opposite the suction grill.
3. Rotate the casing and place the outlet in the position necessary for assembling (indications contained in the use and maintenance booklet of the distribution device).
4. After this has been done fasten the collar again.

### 7.1 FILLING PIPE

The pipe is provided with a coupling elbow fitting and with a **bottom-drawing valve**. This is used for the filling of the tank.

It must be connected to the pump suction (P4) instead of the chain-held stopper.



The connection is **ALWAYS** to be done with the faucet (P2) closed (in position “C”) and the faucet (P6) in position “C”.



**USE ONLY IF CONCURRED FROM THE LAWS OF THE COUNTRY WHERE THE SPRAYER IS USED.** Before utilisation, check the operation and proper sealing of the bottom-drawing valve by pouring water in the piping.

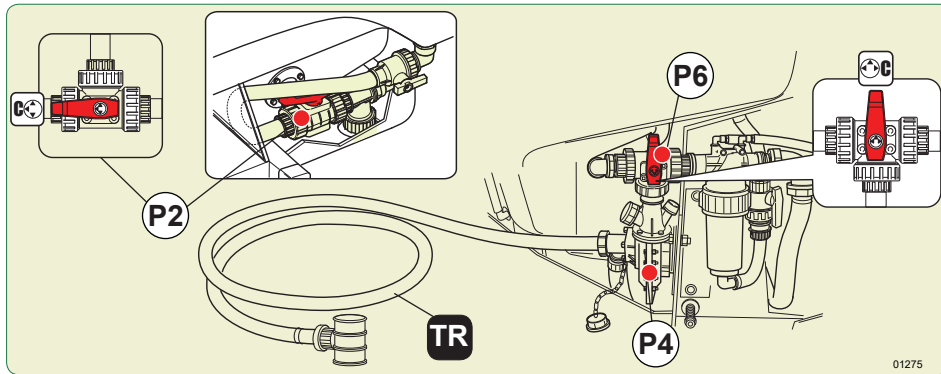

### 7.2 PAIR OF WHEELS



The wheels thread can be adapted to that of the tractor.



**MOUNT THE WHEELS AFTER HAVING HITCHED THE MACHINE TO THE THREE-POINT LINKAGE.**  
**DISMANTLE THE WHEELS BEFORE UNHITCHING THE MACHINE FROM THE THREE-POINT LINKAGE.**

#### ESECUZIONE:

1. Hitch the machine to the tractor and lift it to a height at which the wheels can be mounted.

2.   **Stop the tractor, remove the key from the control panel and ensure that no one operates the three-point linkage’s hydraulic controls. AVOID OPERATING AND STANDING BENEATH THE MACHINE OR WITHIN THE AREA THAT MIGHT BE INVOLVED IN ITS SUDDEN LOWERING.**

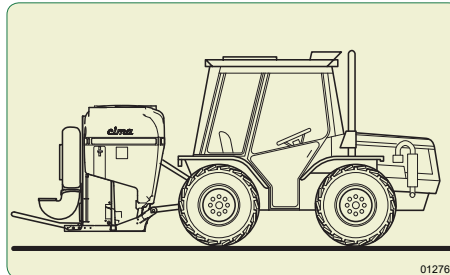

5a6. Complete the filling with water and close the lid of the secondary filler (BS).

5a7. Close the cock (P12) (lever on “c”).

5a8. Put the three-way faucet (P6) in work position (the lever on “A”).

#### 5b. FILLING WITH MEDICINAL MIXTURES OR LIQUID PRODUCTS

5b1. Pour the medicinal mixture envisaged for every loading (together with the water possibly used for the washing of product canisters and of the tools used in the preparation) into the main filler (BP).

5b2. Close the main filler (BP) of the tank.

5b3. Engage the drive outlet (PTO) and take it to a speed of at least 500 RPM

5b4. Complete the filling with water and close the lid of the secondary filler (BS)

6. Move to the treatment place, keeping the Power Takeoff running rate at a minimum value of 500 RPM during all the way.

#### IN THE TREATMENT AREA:

7. Disengage the drive outlet (PTO) and rest the sprayer on the ground.



**Stop the tractor and remove the key from the control panel.**

8. Ensure that the fan is stopped. Engage the fan to the servo amplifier as indicated at point 8.1, then re-close the mobile protection cover.



**Tighten the protection-securing screw properly.**

9. Start the tractor.

10. Lift the unit. Engage the Power Takeoff and set it up to a running rate of at least 500 RPM, in order to carry out a further agitation.



**Use ONLY the PTO at 540 rpm. Engage the PTO with the engine of the tractor at low speed and with maximum modularity, obtaining soft and progressive graft and avoiding abrupt starts of the cardan shaft.**

12. Regulate the operating pressure, by acting on the pressure regulator (P5) (or electric E5) with the distributor electric (E9), or manual (P9), open (DISTRIBUTION).

13. CARRY OUT THE TREATMENT (See the paragraph 10.3).

### 8.3 FILLING WITH THE SPECIFIC PIPE (optional device)



**USE ONLY IF CONCURRED FROM THE LAWS OF THE COUNTRY WHERE THE SPRAYER IS USED.** Before utilisation, check the operation and proper sealing of the bottom-drawing valve by pouring water in the piping.



**THE PUMP MUST NEVER RUN DRY.**

#### EXECUTION:

1. Disengage the fan, see point 8.1.a.

2. Close the 2-way distributor:



- a. if electrical, position the latch switches (E10) on “OFF”.
- b. if manual (P9), set the levers in the horizontal position;

3. Check that:

- P6: is on working position (lever on “A”);
- P12: is closed (lever on “c”);
- P5, pressure regulator: is completely open for the unit's first use, or on the already selected position for the outstanding treatment or for the previous one..

### 8.1.b Fan engagement to perform the treatment

EXECUTION:

1. Disengage the power take off (PTO) and rest the machine on the ground.
2.   **Stop the tractor, remove the key from the control panel and check that the fan is stopped.**
3. Undo the mobile protection cap's fixing screw and rotate it so as to access the disengagement tunnel.
4. Fully press the spring push button, push the front body forward, if necessary, turning it to the right or left, until the frontal teeth of the joint engage the corresponding teeth of the pulley; at the same time, the spring push button must return to the outward position. This way, the body is again integrated with the pulley, thus transmitting the movement to the fan.
5. Reposition the mobile protection cover and suitably tighten the securing screw.
6. Start the tractor and lift the sprayer to position the universal joint shaft.

### 8.2 FILLING THROUGH POURING FROM THE TO



For this type of filling, use the supplementary filler (BS) located in the upper right-hand side of the tank, towards the front of the sprayer (opposite the filler of the hand washing tank).

**THE INLET OF THE FILLER PIPING MUST NEVER COME INTO CONTACT WITH THE ANTI-PARASITIC MIXTURE: IT MUST ALWAYS BE KEPT AT A SAFE HEIGHT ABOVE THE TANK FILLER AND MUST BE EQUIPPED WITH A NON-RETURN VALVE.**



**THE PUMP MUST NEVER RUN DRY.**

EXECUTION:

1. Disengage the fan (for the version where foreseen): see point 8.1.a.
  2. Close the taps of the 2-way distributor:
    - a. if manual (P9), set the levers in the horizontal position;
    - b. if electrical, position the latch switches (E10) on "OFF"
  3. Check that the following cocks
    - P2: is on working position (lever on "A") (and P15, for the versions where foreseen, is closed - lever on "c");
    - P6: is on working position (lever on "A");
    - P12 (for the version where foreseen): closed cock (lever on "c").
    - P5, pressure regulator: is completely open for the unit's first use, or on the already selected position for the outstanding treatment or for the previous one.
  4. Pour water in the tank to about 1/3 capacity through the supplementary filler BS.
- 5a. **FILLING WITH POWDER PRODUCTS BY UTILISING THE MIXER** (for which is foreseen)
- 5a1. Pour the dose of powder into the cup-like filter through the main filler (BP).
  - 5a2. Close the tank's main filler (BP).
  - 5a3. Open the tap (P12) (lever on "a").
  - 5a4. Set the lever of tap (P6) to the "B" position.
  - 5a5. Engage the Power Takeoff and set it up to a running rate of **at least 500 RPM.**





**Use ONLY the PTO at 540 rpm. Engage the PTO with the engine of the tractor at low speed and with maximum modularity, obtaining soft and progressive graft and avoiding abrupt starts of the cardan shaft.**

3. Insert the wheels' axle shafts into the machine's axle.
4. Adapt the wheels' track to that of the tractor.
5. Lock the axle shafts by means of the axle screws.
6. Start the tractor and keep the sprayer lifted during the transfers, lowering it to carry out the treatment.

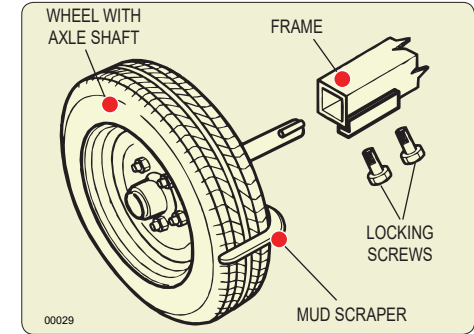

**THE SPRAYER MUST BE LIFTED AT EVERY DIRECTION CHANGE MAKING SURE THAT THE WHEELS ARE NOT RESTING ON THE GROUND.**



		New Plus 42-45		New Plus 50			New Plus 55	
		I. 300	I. 400	I. 300	I. 400	I. 600	I. 400	I. 600
	WHEEL	135/80-R13		135/80-R13	175/70-R13	135/80-R13	175/70-R13	
	INFLATION PRESSURE	2,5 atm		2,5 atm	2,5 atm	2,5 atm	2,5 atm	



**The utilisation of NON ORIGINAL pairs of wheels not equipped with mud scrapers will nullify the machine's warranty.**



**The operating pressure of the tyres is indicated on the decal placed on the rim of each wheel.**

### 7.3 SWIVELLING DEVICE

It is an accessory used to modify the direction of the spraying during the use of the sprayer; it can be used only with the distribution devices with delivery on the one side.

There is two type of swivelling device: manual controlled or hydraulic with remote control panel.



**All indications and instructions are provided in the "Distribution heads - Operation and maintenance instruction" booklet of the distribution devices with which it can be used.**

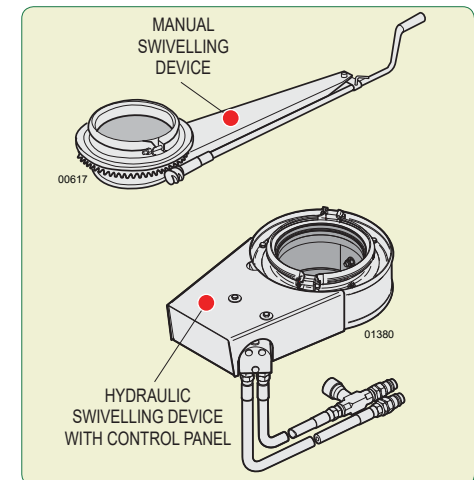

## 7.4 E.P.A. Kit - DELIVERY PROPORTIONAL ADVANCEMENT

(For versions in which his envisaged)

The computerized E.P.A. system executes the monitoring of the distribution parameters for the active automatic control of the distribution proportional to the feed.

Through the constant takeover of the feed speed and the range of the product it is able to regulate the pressure continuously to keep the quantity of distributed product constant in relation to the treated surface.

The Kit is available in the "Teejet® 844AB" version, constituted from:

1. Magnetic induction proximity sensor (speed survey);
2. Pressure transducer (pressure survey);
3. Motorized electric valve (pressure regulation);
4. Computerized unit;
5. Dedicated printer (on demand).

For further information refer to the specific handbook.

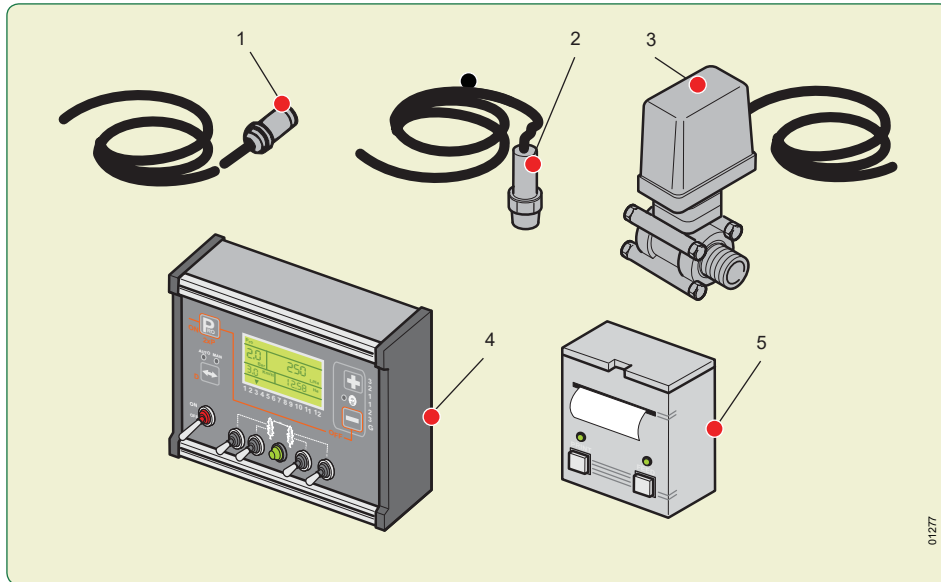

**FILLING MUST BE CARRIED OUT WITH THE MACHINE ON A FLAT SURFACE. ON THE SITE, BEFORE THE OPERATION, THE DOSES OR THE MIXTURES TO BE POURED INTO THE TANK MUST BE PREDISPOSED.**





**IT IS NECESSARY TO ALWAYS MAKE USE OF PERSONAL PROTECTION.**

## 8.1 FOREWORD - USE OF THE FAN DISENGAGEMENT

(For versions in which his envisaged)

### 8.1.a Disengagement of the fan

EXECUTION:

1.   **Stop the tractor, remove the key from the control panel and check that the fan has stopped**
3. Undo the mobile protection cap's fixing screw and rotate it so as to access the disengagement tunnel.

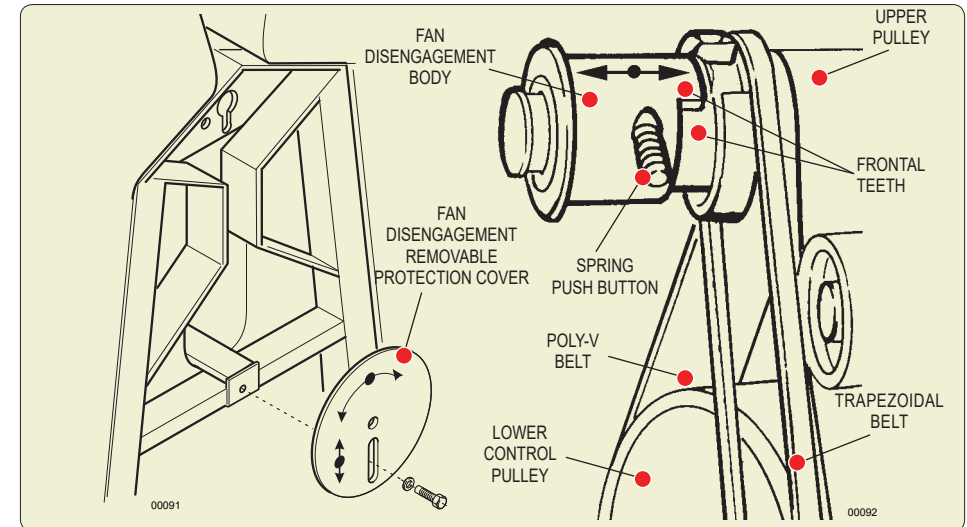

4. Fully press the spring push button and pull the front element until it springs out. The body disengaged from the retaining joint must turn freely: the pump will operate and the fan will thus be excluded.
5. Reposition the mobile protection cover and fasten the locking screw properly.
6. Start the tractor, lift the sprayer to position the universal joint shaft and carry out the filling operation..