

CE

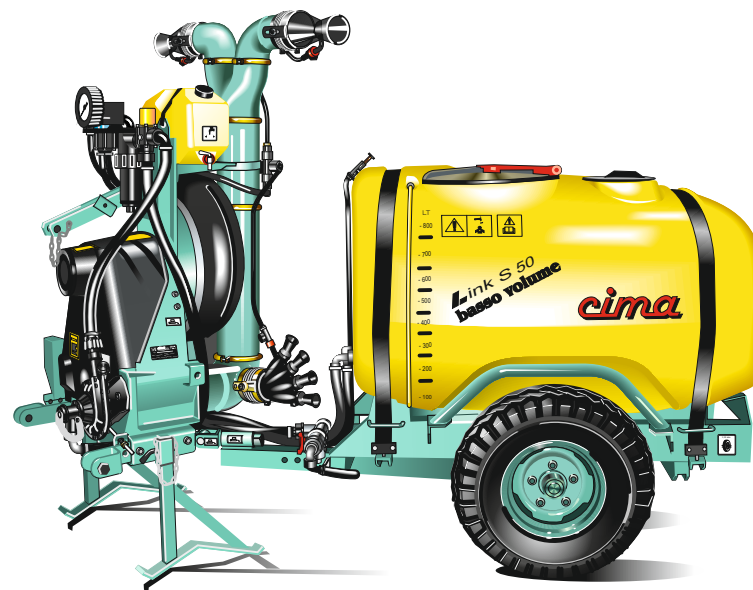

LINK

OPERATION AND MAINTENANCE INSTRUCTIONS

cima[®] S.p.A.

27040 Montù Beccaria - Loc. Molino Quaroni - (PV) - ITALIA
Tel. +39.0385.246636 r.a. - Fax +39.0385.246637
<http://www.cimaitalia.com>

cima[®]

atomizzatori e impolveratori

Dear Customer, thank you very much!

*We want to congratulate with you, for having chosen a **cima**® sprayer.*

Your choice shows the wisdom of the well-informed Purchaser, aware of the fact, that the required features of quality, technique and reliability must be satisfied at the right price!

Our continuous engagement in R&D and in testing our machines allows us to realize products able to offer the best performances, a high reliability and a great easiness of use at the same time !

Our first goal, is to get our Customers happy for having met us!

The "Spare parts catalogue" of this sprayer/sprayhead is available in the "restricted area" on website www.cima.it.

In order to accede, use:

Username: **sprayer**

Password: **844719KE**

Where we are





DICHIARAZIONE DI CONFORMITÀ		CE	
ai sensi della direttiva 98/37/CE del 22/06/98 e successive modificazioni			
DECLARATION OF CONFORMITY as directive: 98/37/CE - 22/06/98 and subsequent modifications	CE	DECLARATION DE CONFORMITE selon la directive 98/37/CE - 22/06/98 et modifications ultérieures	
ÜBERREINSTIMMUNGS-ERKLÄRUNG lt. Direktiven 98/37/CE - 22/06/98 und nachfolgenden Änderung	CE	DECLARACION DE CONFORMIDAD con arreglo a la Directiva 98/37/CE - 22/06/98 y modificaciones siguientes	
CIMA s.p.a. 27040 MONTÙ BECCARIA (PV) - ITALY - Loc. Molino Quaroni			
DICHIARA SOTTO LA PROPRIA RESPONSABILITÀ CHE LA MACCHINA:	HEREWITH DECLARES, UNDER THEIR PERSONAL RESPONSIBILITY, THAT THE FOLLOWING MACHINE:	DECLARONS SOUS NOTRE RESPONSABILITE QUE LA MACHINE DECRITE CI-APRES:	BESTÄTIGT HIERMIT UNTER IHRER PERSÖNLICHEN VERANTWORTUNG, DASS DIE MASCHINE:
SERIE, TIPO - MODEL, TYPE - SERIE, TYPE - MODEL, TYP - SERIE, TIPO:			
<input style="width: 100%;" type="text"/>			
MATRICOLA - SERIAL - MATRICULE - SERIAL - MATRICULA NR.:			
<input style="width: 100%;" type="text"/>			
E' conforme ai Requisiti essenziali di Sicurezza e di Tutela della Salute di cui alla Direttiva 98/37/CE del 22/06/98 e sue successive modificazioni. Per la verifica della Conformità di cui alle Direttive sopra menzionate, sono state consultate le seguenti: Norme armonizzate: EN 294 EN 349 EN 907.			
Conforms to the essential Safety regulation as well as the Health requirements as per European Economic Community Directive: 98/37/CE - 22/06/98 and subsequent modifications. For the verification of conformity as per above mentioned directives the following official EN norms have been consulted: Harmonized norms: EN 294 EN 349 EN 907.	Est conforme aux exigences de Sécurité et de Sauvegarde de la Santé dont à la Directive 98/37/CE - 22/06/98 et modification ultérieures. Pour vérifier la conformité aux directives susmentionnées, ont été prises en compte les normes suivantes: Normes harmonisées: EN 294 EN 349 EN 907.		
Stimmt mit den wesentlichen Requisiten der Sicherheitsvorschriften und der Gesundheitsvorsorge lt. EWG Direktive Nr. 98/37/CE - 22/06/98 und nachfolgenden Änderungen überein. Für die Überprüfung dieser Übereinstimmungs-Erklärung lt. obigen Direktiven sind folgende Normen konsultiert worden: Normen: EN 294 EN 349 EN 907.	Cumple con los requisitos esenciales de Seguridad y de Preservación de la Salud contenidos en la Directiva 98/37/CE - 22/06/98 y modificaciones siguientes. Para comprobar la conformidad a la que se refieren las Directivas anteriormente citadas, se han consultado las siguientes: Normas Armonizadas: EN 294 EN 349 EN 907.		
Responsabile della Sicurezza - The Security Official - Responsable Sécurité et Homologations - Der Sicherheits-Beamter - Responsable de la Seguridad			
Montù Beccaria (PV) Data, Date, Datum, Fecha, _____		Smeraldi Paolo 	

LOW-VOLUME SPRAYERS TRAILER-MOUNTED MODELS

LINK

Model:

Serial Number:

OPERATION AND MAINTENANCE INSTRUCTIONS



27040 Montù Beccaria - Loc. Molino Quaroni - (PV) - ITALIA
 Tel. +39.0385.246636 r.a. - Fax +39.0385.246637
<http://www.cimaitalia.com>

17 **NOISE LEVEL** **17**

Spray atomiser model	Aerial noise emitted L qA - dB(A)
LINK 45	92,0 – 0,2
LINK 50	93,0 – 0,2

LINK009GB

18 **WARRANTY** **18**



THE OWNER AND/OR THE OPERATOR OF THE SPRAYER ARE NOT PERMITTED TO MODIFY THE STRUCTURE OR THE SPECIFIC OPERATION OF THE SPRAYER ITSELF. ANY REPAIRING INTERVENTION HAS TO BE CARRIED OUT EITHER AT THE DISTRIBUTORS' OR AT THE C.I.M.A. S.p.A. AUTHORIZED WORKSHOPS, OTHERWISE ANY KIND OF WARRANTY IMMEDIATELY CEASES AND C.I.M.A. S.p.A. IS CLEARED OF ANY CONSEQUENT AND/OR IMPLIED RESPONSIBILITY.

The machines are guaranteed for **12 months** from the delivery date. During this period, spare parts not subject to wear and tear and confirmed as defective will be replaced free of charge, not including of transport and labour expenses.

The warranty will be void:

- a. should repairs be carried out without the consent of the manufacturer or one of its sale points.
- b. should original spares not be used.
- c. should the machine be used for purposes other than those for which it was specifically designed and destined.
- d. should the instructions of this manual, together with those relating to the integrative parts that make it up, not be observed.

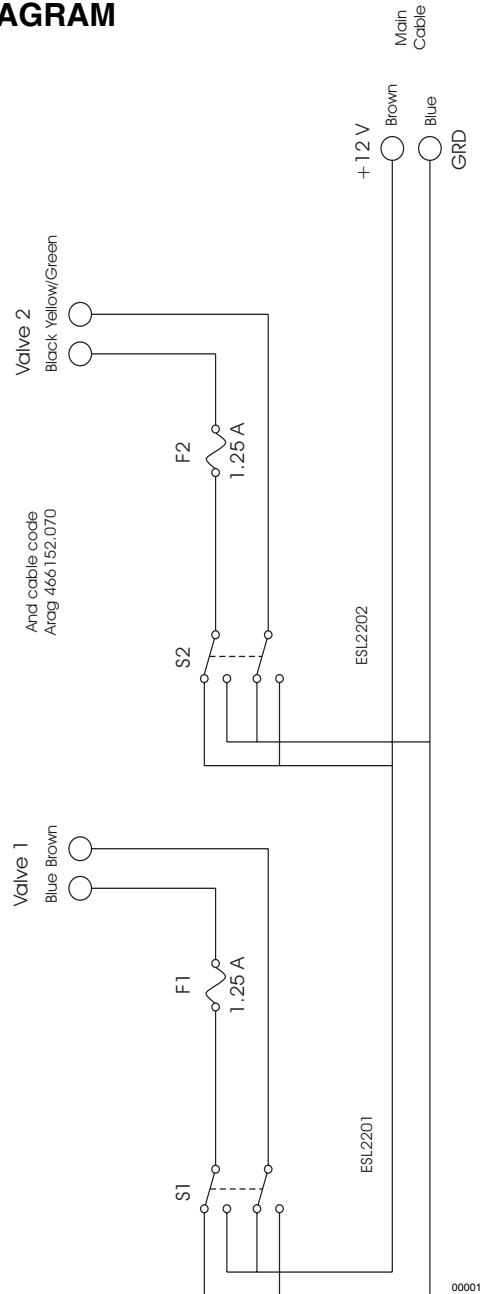

LISTING OF VALID PAGES

This publication consists of 64 pages, subdivided as follows:

N° OF PAGE	REVISION	BASE
from I to VI	01	January 2002
from 1 to 58	01	January 2002

ADDITIONAL RECORDS AND VARIANTS

REVISION	DESCRIPTION
00	First Edition, March 2001
01	Second Edition, January 2002
02	
03	
04	
05	
06	
07	
08	

GENERAL INDEX

1	FOREWORD	1
1.1	PUBLICATION IDENTIFICATION	1
1.2	ATTACHED PUBLICATIONS	1
1.3	PURPOSE OF PUBLICATION	1
1.4	REFERENCE TO REGULATIONS	1
1.5	USING THE MANUAL	1
1.6	UPDATES	2
2	GLOSSARY	3
2.1	TERMINOLOGY	3
2.2	ABBREVIATIONS	3
2.3	DECALS	3
3	GENERAL INFORMATION	8
3.1	MACHINE IDENTIFICATION	8
3.2	TECHNICAL ASSISTANCE	8
3.3	SAFETY NOTICES	8
3.4	SAFETY SYSTEMS	9
3.5	HANDLING OF AGRO-CHEMICALS	10
3.5.1	Storage	10
3.5.2	Specific equipment	10
3.5.3	Disposal of empty containers and agro-chemical residues	11
3.5.4	Personal means of protection	11
4	MACHINE'S STRUCTURAL ANALYSIS	12
4.1	FRAME	13
4.2	FAN SERVO AMPLIFIER	17
4.3	HYDRAULIC CIRCUIT COMPONENTS	18
4.4	TECHNICAL DATA	26
4.4.1	Sprayers dimensions and weights	26
4.4.2	Wheel's: dimensions and operating pressures	26
4.4.3	Technical specifications for fans and pump	27
5	COUPLING MODALITIES	28
5.1	HITCHING TO THE TRACTOR	28
5.2	MOUNTING OF THE TRANSMISSION SHAFT	29
5.3	INSTALLATION OF REMOTE CONTROLS	29

16

INTEGRATIVE DIAGRAMS

16

16.1 - HYDRO-PNEUMATIC DIAGRAM

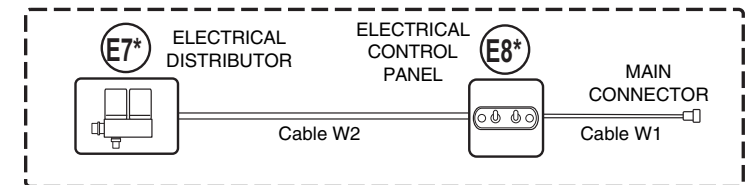
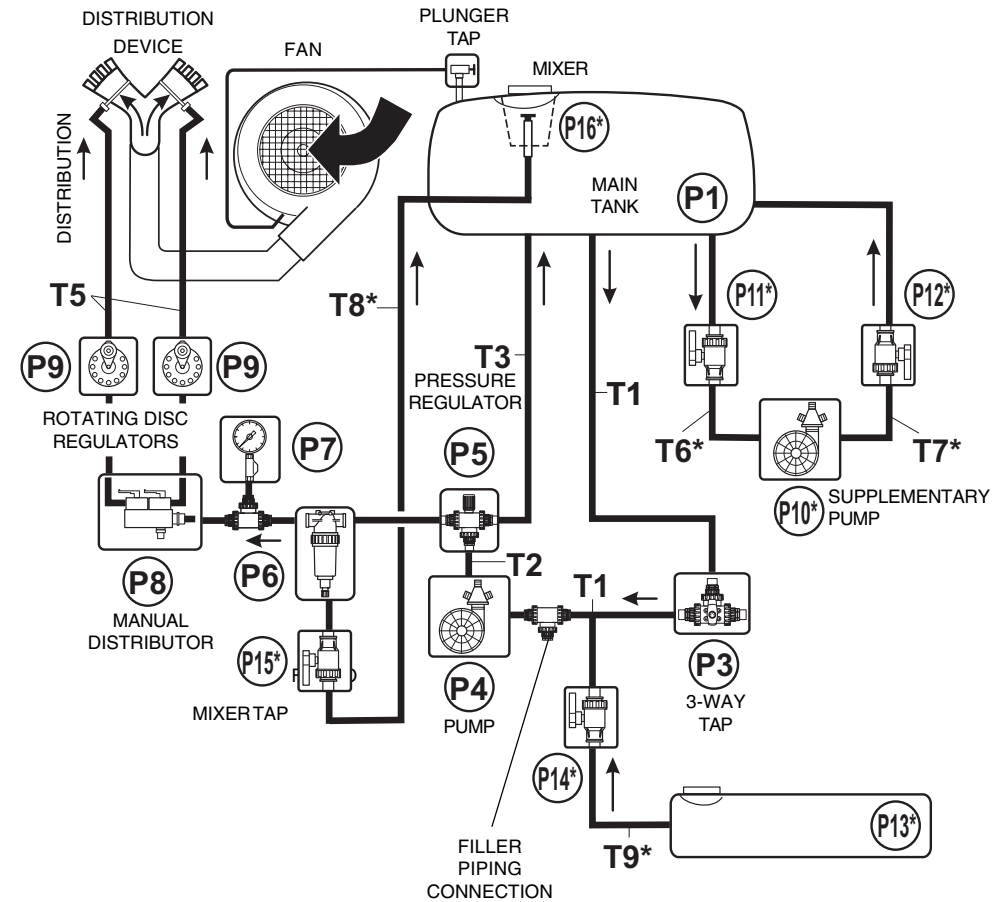

* For the versions in which it is envisaged

15.2. - REPLACEMENT OF ELECTRICAL PANEL'S FUSES



Stop the engine and remove the ignition key from the tractor's control panel.

1. Undo the fuse-carrier cover;
2. Replace the faulty fuse and screw back the cover.
 - Fuse: 1.25 A, delayed.

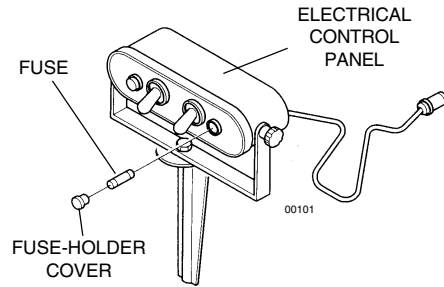

15.3. - PRESSURE GAUGE REPLACEMENT



Stop the motor and remove the starting key from the tractor control panel.

1. Unscrew and remove the defective pressure gauge ;
2. Replace the pressure gauge.

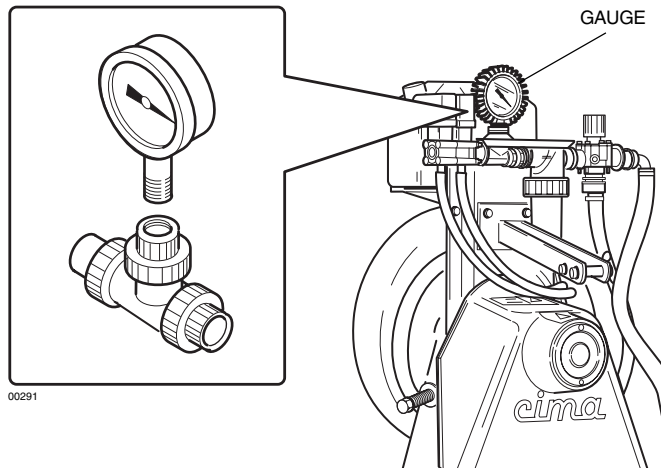

ANY OTHER INTERVENTION HAS TO BE CARRIED OUT AT A C.I.M.A. CUSTOMERS' SERVICING CENTER.

5.3.1	Manual 2-tap distributor - P8	29
5.3.2	Electrical control panel - E8	30
6	DISTRIBUTION DEVICES	31
6.	TYPE AND IDENTIFICATION CODES	31
7	ACCESSORIES	32
7.1	FILLER PIPE	32
7.2	MANUAL TURN DEVICE	32
8	FILLING	33
8.1	FOREWORD – USE OF THE FAN DISENGAGEMENT	33
8.1.a	Disengagement of the fan	33
8.1.b	Fan engagement to perform the treatment	34
8.2	FILLING THROUGH POURING FROM THE TOP	34
8.3	FILLING WITH THE SPECIFIC PIPE	35
9	AGITATION	38
10	TANK AND HYDRAULIC CIRCUIT DRAINING	38
11	OPERATING PROCEDURES	39
11.1	PRELIMINARY OPERATIONS TO TREATMENT	39
11.2	PREPARATORY OPERATIONS TO TREATMENT	39
11.3	THE TREATMENT	41
11.4	END OF TREATMENT - STORAGE	41
11.4.1	Daily	41
11.4.2	End of seasonal cycle	42
12	TRANSPORT	43
13	MAINTENANCE OPERATIONS	44
13.1	LUBRICATION	44
13.2	FAN SHAFT SUPPORT OIL LEVEL CHECK	45
13.3	FAN SHAFT SUPPORT OIL REPLACEMENT	45
13.4	CLEANING OF FILTER'S CARTRIDGE	46
13.5	PURGING OF RESIDUES FROM FILTER	47
13.6	CLEANING OF THE FAN	47
13.7	FAN BELT TENSIONER	48
13.8	PUMP BELT TENSIONER	48

13.9	TANK REMOVAL OR REPLACEMENT	49
13.10	TABLE OF MAINTENANCE OPERATIONS	50
14	FAULTS FINDING	51
15	REPAIRS ALLOWED	53
15.1	REPLACEMENT OF PUMP CONTROL BELT	53
15.2	REPLACEMENT OF ELECTRICAL PANEL'S FUSES	54
15.3	PRESSURE GAUGE REPLACEMENT	54
16	INTEGRATIVE DIAGRAMS	55
16.1	HYDRO-PNEUMATIC DIAGRAM	55
16.2	WIRING DIAGRAM	56
17	NOISE LEVEL	57
18	WARRANTY	57
19	ATTACHMENT : DECLARATION OF COMPLIANCE	58



THE OWNER AND/OR THE OPERATOR OF THE SPRAYER ARE NOT PERMITTED TO MODIFY THE STRUCTURE OR THE SPECIFIC OPERATION OF THE SPRAYER ITSELF. ANY REPAIRING INTERVENTION HAS TO BE CARRIED OUT EITHER AT THE DISTRIBUTORS' OR AT THE C.I.M.A. S.p.A. AUTHORIZED WORKSHOPS, OTHERWISE ANY KIND OF WARRANTY IMMEDIATELY CEASES AND C.I.M.A. S.p.A. IS CLEARED OF ANY CONSEQUENT AND/OR IMPLIED RESPONSIBILITY.

15.1 - REPLACEMENT OF PUMP CONTROL BELT



Stop the engine and remove the key from the tractor's control panel.

1. Remove the fan assembly protection, by unscrewing the screw fastening it to the frame.
2. Completely unscrew the tightener spring adjusting screw: the pump support plate will so freely turn.
3. Remove the worn out belt, by getting it first loose from the pump pulley and then from the upper control pulley.
4. Insert the belt first into the race of the upper pulley and then into the race of the pump pulley.
5. Reinstall the spring of the belt-tensioner according to the suggested tensioning conditions.
6. Mount back the fan assembly protection casing.

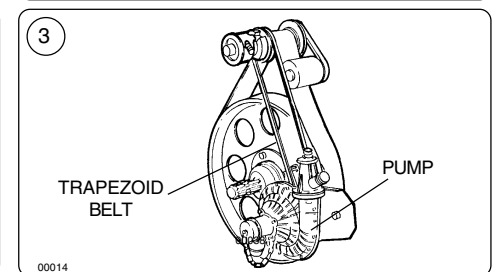
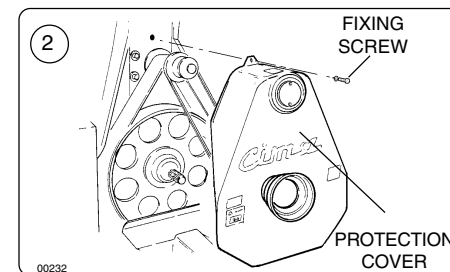
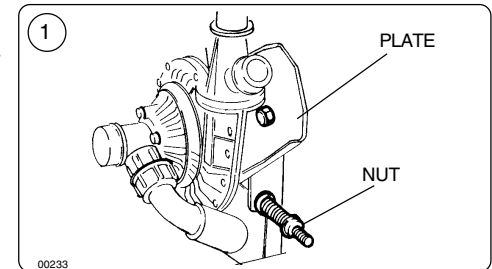

Carefully tighten the screws that were undone during the belt replacement.

2. CAUSE: the 2 drive outlets are out of alignment or are not parallel.
REMEDY: Position the 2 drive outlets (PTO) correctly.

E. FAULT: Continuous and abnormal noise level, accompanied by vibrations of fan unit.

1. CAUSE: Broken fan shaft bearings.
REMEDY: Refer to the C.I.M.A. service point.

F. FAULT: Intermittent operation of the whole distribution device

1. CAUSE: Faulty sealing of the hydraulic circuit, going from the tank's (T1) suction piping to the manual (P8) or electrical (E7) distributor.
REMEDY: Carefully inspect all the points at which suction of air can take place, including as well those at which no liquid seepage is detected. Check the proper tightening of ring nuts, fittings and clamps. Check the efficiency of the sealers and the integrity of the piping. Reinststate the efficiency and replace parts that might have been found to be defective.

G. FAULT: Intermittent spraying only on the one side of the distribution device

1. CAUSE: Faulty sealing of the hydraulic circuit going from the manual (P8) or electrical (E7) distributor to the distribution point involved.
REMEDY: As per point F.1.

H. FAULT: No spraying action delivered: totally or only on the one side of the distribution device

1. CAUSE: Manual distributor (P8) taps dirty or clogged, or pump suction piping clogged by hardened product deposits.
REMEDY: Clean.
- 1b.CAUSE: Electrical distributor (E7) taps blocked by incrustations in the closed position.
REMEDY: After having lifted the lid off, turn the nut controlling the stroke of the tap.
- 2b.CAUSE: Fuses of the electrical control panel interrupted when the electrical (E7) distributor's taps are closed.
REMEDY: Replace the fuses after having manually checked the solenoid valves' operation.
- 3b CAUSE: Power cable W1 of the electrical panel wrongly connected with the taps of the electrical distributor (E7) in the closed position.
REMEDY: Connect correctly.
4. CAUSE: Defective electrical connections.
REMEDY: Refer to the C.I.M.A. service point.
5. CAUSE: Pump defective (only in case total delivery missing).
REMEDY: Refer to the C.I.M.A. service point.
6. CAUSE: Broken pump belt.
REMEDY: Replace the belt (See Paragraph 15.1).



THE CAUSES AND REMEDIES FOR THE FAULTS CONCERNING THE DELIVERY OF THE SPRAYING BY ONE OR MORE DIFFUSERS ARE INDICATED IN THE USE AND MAINTENANCE MANUAL OF EACH SPRAYHEAD.

1.1 - PUBLICATION IDENTIFICATION

The "OPERATION AND MAINTENANCE INSTRUCTIONS" manual is an integrative part of the sprayers. It is identified by a Publication No. located on the third cover page, and through which the document can be identified, traced and/or subsequently referred to.
 The information elements contained herein are updated as at the date of publication. C.I.M.A. S.p.A. reserves the right to modify its machines without notice, with the purpose of applying technical enhancements, and it declines all responsibility for possible omissions from the publication.

1.2 - ATTACHED PUBLICATIONS

- Spare parts catalogue;
- Distribution devices, "Operation and maintenance instruction"
- Distribution devices, "Spare parts catalogue"
- "Low Volume - Instructions for sprayer adjustment"
- "Modalities for filling through the specific pipe" diagram
- "Modalities for filling through pouring from the top" diagram

1.3 - PURPOSE OF PUBLICATION

All indications contained in this manual are aimed at the user of the sprayer.
 The duration of the machine and its operation, the operator's safety and the respect for the environment are dependent upon scrupulous observance of the stated norms.
 Before making use of the sprayer, the user must read, understand and abide by all regulations listed in this manual.

1.4 - REFERENCE TO REGULATIONS

This manual was set out conforming to the regulations contained in following documents:

- Attachment "I" to Directive 89/392/C and subsequent modifications (letters "b", "c" of point 1.1.2 and point 1.7.4);
- UNI EN 907 - 1997 and to all the documents in it quoted.

1.5 - USING THE MANUAL

Read every part of this manual, paying attention to the **WARNING** and **DANGER** indications both on the text and on the machine or on components.
 All operations suggested by the manual will have to be followed with the utmost care and only after having understood the negative consequences of improper usage.

The following “symbols “ are used within the text in order to highlight and visually identify the importance of the various types of information:



Indicates important additional information



Non observance can result in permanent damage to the sprayer.



Highlights possibly dangerous situations to people.

The manual, with relevant attachments and possible integrating issues, must be kept with the utmost care and must always be complete, integer and legible in every part. Should it be mislaid it is imperative to immediately request a duplicate from C.I.M.A. S.p.A. Should the decals originally applied on the machine be mislaid, damaged or become incomprehensible, they should be promptly replaced.

For every type of distribution device (Head) delivered with the sprayer, a specific user and maintenance manual is attached. All the head manuals must always accompany the one of the machine.



- The manual must always be kept for the sprayer’s whole operational life.
- Any modification received must be permanently inserted in this publication.
- The manual must be ceded with the sprayer should this be sold.

1.6 - UPDATES

Possible updates that C.I.M.A. S.p.A. will provide the owner of the sprayer will be accompanied by instructions to insert in this publication.

Should the machine be sold, the owner must inform the new purchaser that he should notify C.I.M.A S.p.A. of his address in order to receive possible future integrating issues and/or updates.

A. FAULT: By utilising the filler piping the pump doesn’t operate (suction)



It is necessary to disengage the drive outlet (PTO) and wait for it to stop rotating before repeating the filling operation.

1. CAUSE: the quantity of water poured into the tank is insufficient to trigger the pump.
REMEDY: Add water to the tank until the pump starts its cycle.
2. CAUSE: the filler piping sucks in air.
REMEDY: Completely submerge the suction filter of the filler piping.
3. CAUSE: Hydraulic circuit not sealing properly.
REMEDY: Check the tightening of ring nuts, fittings and clamps. Check the efficiency of sealers and that piping elements are not cracked or broken. Replace parts that are possibly found to be defective.
4. CAUSE: Slipping of the pump’s belt.
REMEDY: Check the tension of the belt-tensioner’s spring.
5. CAUSE: The pump’s belt might be broken.
REMEDY: Replace the belt.
6. CAUSE Defective pump.
REMEDY: Contact the C.I.M.A. Customers’ service.

B. FAULT: Leakage and dripping from the pump

1. CAUSE: Non-sealing of the fittings and clamps connecting the piping to the pump.
REMEDY: Check for proper tightening of ring nuts and clamps. Check the efficiency of the sealers. Replace parts that are possibly found to be defective.
2. CAUSE: The sealers (O.Rings) of the external coupling flanges don’t seal the pump properly.
REMEDY: Refer to the C.I.M.A. service point.
3. CAUSE: Mechanical sealing defective.
REMEDY: Refer to the C.I.M.A. service point.

C. FAULT: Drop in pressure of the hydraulic circuit signalled by the gauge

1. CAUSE: Dirty filter.
REMEDY: Clean the cartridge
2. CAUSE: Faulty sealing of the hydraulic circuit.
REMEDY: Check the operation of the pump and its belt. Check the proper tightening of ring nuts, fittings and clamps. Check the efficiency of the sealers and the integrity of the piping. Replace the parts that are possibly found to be defective.
3. CAUSE: Centrifugal pump defective. See “B”.
REMEDY: As per point “B”.
4. CAUSE: Gauge defective.
REMEDY: Replace the pressure gauge.

D. FAULT: Vibration of fan unit

1. CAUSE: Fan dirty.
REMEDY: Clean. (It is advisable to refer to the C.I.M.A. service point).

13.10 - TABLE OF MAINTENANCE OPERATIONS

CHECK	SEASON START TREATMENTS I	BEFORE EVERY TREATMENT	END OF EVERY TREATMENT	SEASON-END TREATMENTS	INTERVAL
Fan belt-tensioner spring: CHECK LENGTH 9-12cm.	YES	YES	**	**	**
Pump belt-tensioner spring: CHECK LENGTH 4-5cm.	YES	YES	**	**	**
Fan shaft support: CHECK OIL LEVEL	YES	YES	**	**	8 hours
Fan shaft support: REPLACE OIL LEVEL	**	**	**	**	Yearly
Fan belt-tensioner support: GREASING	**	**	**	YES	200 hours
Free wheel: GREASING	**	**	**	YES	200 hours
Pump bearing: OILING	**	**	**	YES	6 month
Wheels bearings: GREASING	**	**	**	YES	200 hours
Articulated joint : GREASING (3 points)	**	**	**	YES	200 hours
Filter: CHECK CLEANING	**	**	YES	YES	**
Fittings and piping: CHECK GOOD CONDITION	YES	YES	**	YES	**
Clamps and fittings: CHECK PROPER TIGHTENING	YES	YES	**	YES	**
Wheels: CHECK THE NUT TIGHTENING AND CHECK TYRE PRESSURE	YES	YES	**	YES	**
Axle and wheels hubs: CHECK THE BOLT TIGHTENING	YES	YES	**	YES	**
Sprayer: EXTERIOR WASHING	**	**	YES	YES	**
Hydraulic circuit and tank: COMPLETELY DRAIN AND WASH	**	**	YES	YES	**
Sprayer: STORAGE	**	**	**	YES	**

2.1 - TERMINOLOGY

The terms FRONT, REAR, RIGHT and LEFT utilised in this publication refer to the sprayer as seen by an operator from behind the operative unit along the drive line and facing it: **the rear part** of the machine is that closest to the operator, and is where the distribution device (Head) is mounted - and **the front part** is the one that gets attached to the tractor.

2.2 - ABBREVIATIONS

g	grams
h	hour
ha	hectare
ha/h	hectare per hour
l	litres
l/h	litres per hour
l/ha	litres per hectare
kg	kilogram
kg/cm ²	kilograms per square centimetre (atmosphere)
km	kilometre
km/h	kilometres per hour
Lm	width in metres
m	metre
Mesh	N° of meshes per linear inch
Micron	1/1000 of millimetre
PTO	power take-off
RPM	revs per minute
s	seconds

2.3 - DECALS

The safety and use/maintenance decals are applied to the machine are described in the following paragraph.



Every decal is marked with its part number, in case it needs to be replaced.

Safety

- 1 - 95001 - **STOP THE ENGINE AND REMOVE THE KEY FROM THE TRACTOR'S CONTROL PANEL BEFORE CARRYING OUT ALL MAINTENANCE OR REPAIR OPERATIONS**
 - Positioned over the servo amplifier unit protection plastic casing.

- 2 - 95004 - **DANGER OF CONTAMINATION BY CONTACT OR POISONOUS PRODUCTS INHALATION**
 - Positioned above the main tank, in the forward part, next to the filler spoutes.
- 3 - 95005 - **DANGER, PARTS IN MOTION. BEFORE REMOVING PROTECTION GUARDS, STOP THE TRACTOR, REMOVE THE KEY FROM THE TRACTOR'S CONTROL PANEL AND ENSURE THAT ALL MOVING PARTS HAVE STOPPED**
 - Positioned on the fan casing next to the outflow vent.
- 4 - 95008 - **THE SPRAYER ISN'T EQUIPPED WITH THE PERSONAL CLEANING ADDITIONAL TANK**
 - Visible on the hands-washing tank housing, when this isn't mounted.
- 5 - 95015 - **BEFORE UTILISING THE RELEASE DEVICE, STOP THE TRACTOR, REMOVE THE KEY FROM THE TRACTOR'S CONTROL PANEL AND ENSURE THAT THE FAN HAS STOPPED**
 - Positioned on the servo amplifier unit protection plastic casing cover.
- 6 - 95010 - **MAXIMUM OPERATING SPEED OF THE DRIVE OUTLET (PTO): 540 RPM**
 - Positioned near the drive outlet.
- 7 - 95007 - **DANGER OF SPRAYS: KEEP AT A SAFE DISTANCE**
 - Positioned on the upper part of the fan casing.
- 8 - 95006 - **WARNING: CONSULT THE USER AND MAINTENANCE MANUAL BEFORE USING OR INTERVENING ON THE MACHINE**
 - Positioned on the left-hand side of the tank, in the forward part of this one.
- 9 - 95009 - **DANGER: GLOVES MUST BE USED TO EMPTY THE TANK**
 - Positioned on the unit's left side, near the draining cock.
- 10 - 95077 - **IT IS FORBIDDEN TO ENTER INTO THE TANK!**
 - Positioned on the tank left side, near the main filler.

Use and maintenance

- 11 - 95055 - **CAUTION, THE UNIT ISN'T HOMOLOGATED FOR CIRCULATING ON ROAD**
 - Positioned on the tank, in the left front section.
- 12 - 95079 - **CHECK THE OIL LEVEL EVERY 8 HOURS: FAN SHAFT BEARINGS**
 - Positioned on forward of the chassis, on the left-hand side
- 13 - 95054 - **IGREASE EVERY 200 HOURS: FAN TIGHTENER SUPPORT, FREEWHEEL AND WHEEL HUBS**
 - Positioned on the right front side frame
 - Positioned in the front section, near the Power Takeoff.
 - Positioned on the wheel
 - On the drawbar, near the articulated joint.
- 14 - 95076 - **LUBRICATE EVERY 6 MONTHS: PUMP BEARINGS**
 - Positioned on the left side of the servo amplifier unit protection plastic casing, near the pump.
 - Positioned on the right side of the servo amplifier unit protection plastic casing, near the additional agitation pump (for the models where it is foreseen)
- 15 - 95057 - **HAND WASHING TANK TAP**
 - Positioned on the left-hand side of the tank, next to the tap.
- 16 - 95065 - **WARNING: NEVER OPERATE THE SPRAYER WITHOUT LIQUID IN THE TANK**
 - Positioned on the tank, in the left section.

13.9- TANK REMOVAL OR REPLACEMENT



This operation has to be carried out by a C.I.M.A. service point



The operation has to be carried out by complete absence of liquid residuals both inside the tank and in the hydraulic circuit

1. Make the tank free from all the hydraulic and pneumatic connections.
2. Loosen the screw nut (4), for tensioning the tank fastening belt.
3. Remove the split pin (3).
4. Unscrew the belt end (2), in order to make the tank free; carry out the same operation for the second belt (1).
5. Lift the tank and remove it from the frame.
6. Either replace or reposition the tank.
8. Position again the belts in the relevant seats.
9. Screw on every belt the adjusting screw nut, in order to get the belts themselves tensioned and to firmly fasten the tank to the frame.
10. Mount back both the safety split pins.



Check the tank fastening belt tension before each treatments.

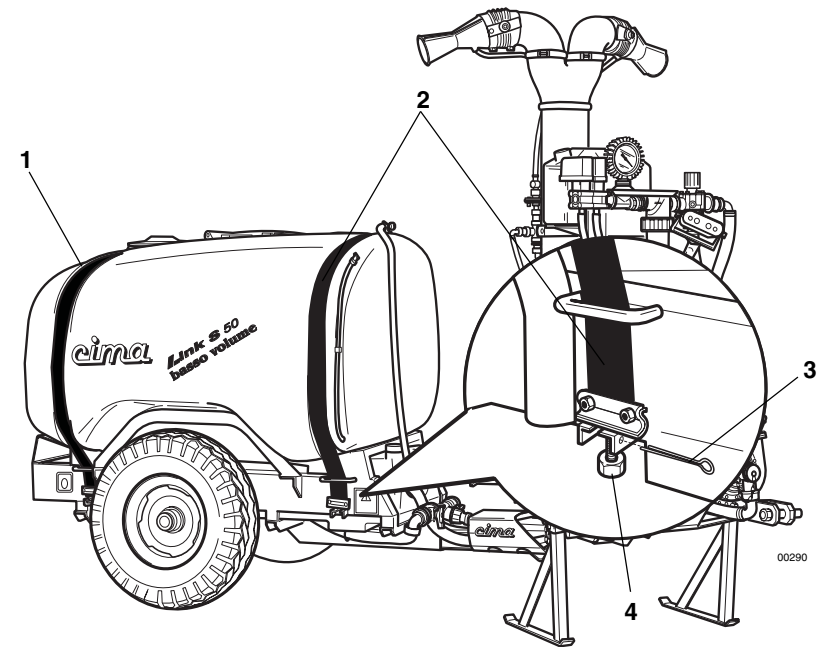

13.7 - FAN BELT TENSIONER

Check length "L" of the spring (refer to Picture): it should be in tension between 9 and 12 cm.

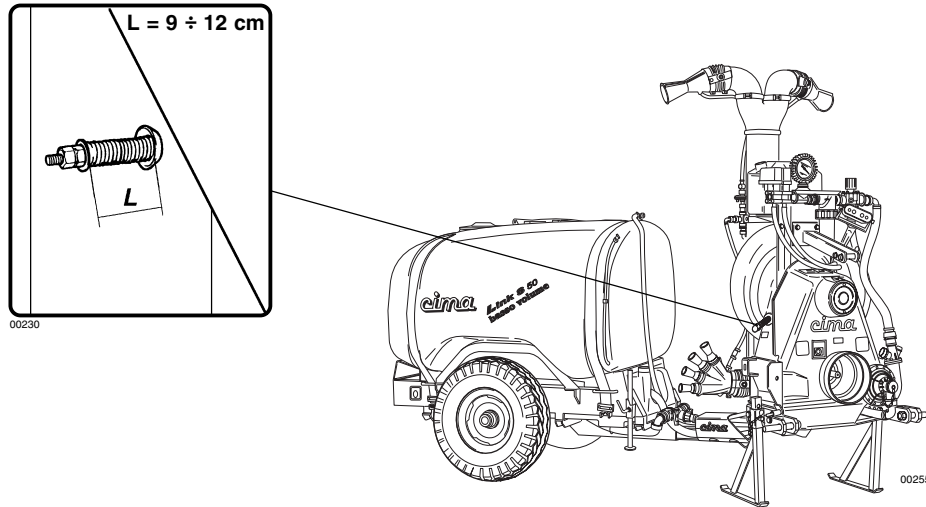

13.8 - PUMP BELT TENSIONER

Check length "L" of the spring (refer to picture): it should be in tension between 4 and 5 cm.

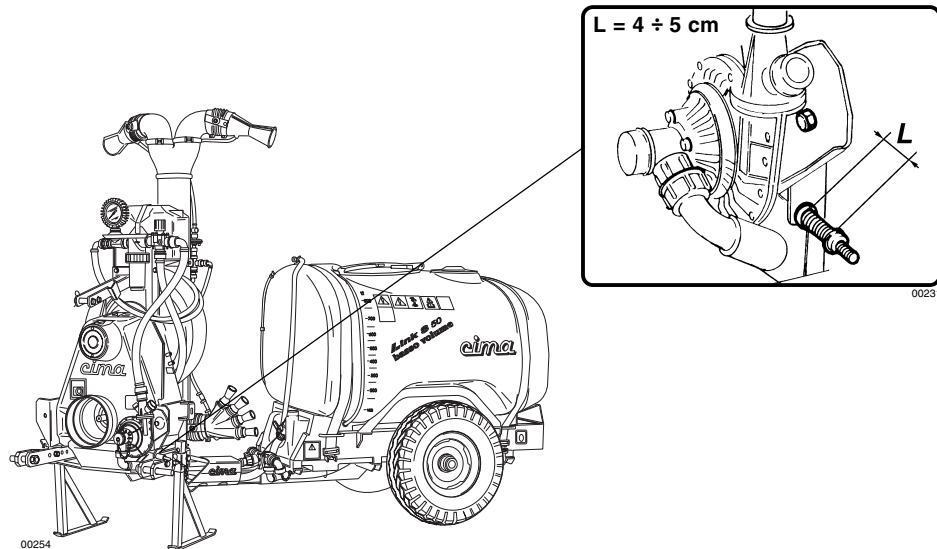

- 17 - 95069 - INDICATIONS FOR THE USE AND MAINTENANCE OF THE SOLENOID VALVES
 - Positioned on the right side of the servo amplifier unit protection plastic casing.
- 18 - 95060 - INDICATION OF THE WHEELS OPERATING PRESSURE
 - 95056 - POSITIONED ON THE FRAME LEFT AND RIGHT REAR SECTIONS.
- 19 - 95075 - INDICATION ON THE OPERATION OF THE 3-WAY TAP (P3)
 - Positioned on the articulated joint casing, near the cock (P3).

Positioning of the safety, use and maintenance decals

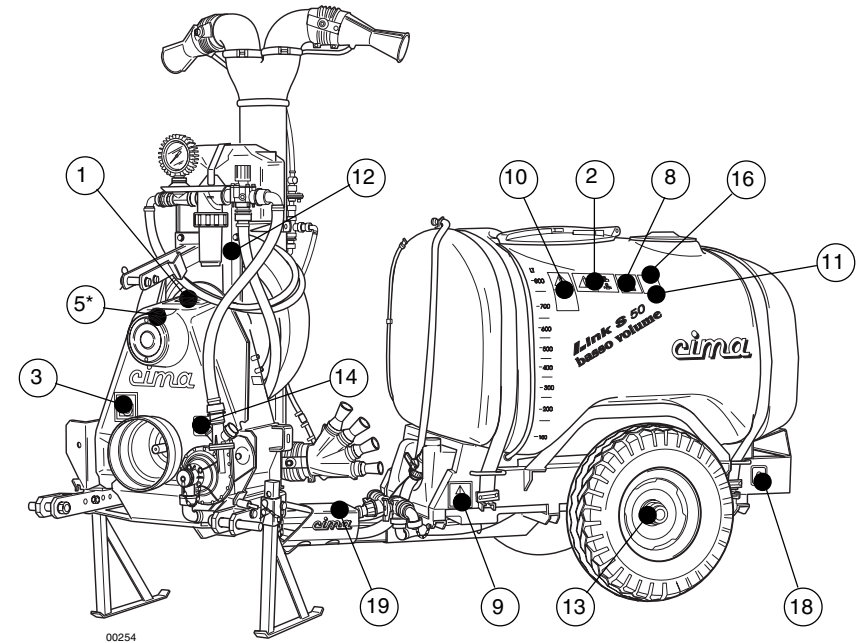

NOTE: The numbers with the asterisk (*) indicate the adhesives relevant either to optional components or to accessories to be applied ONLY on the models and versions on which this is foreseen.

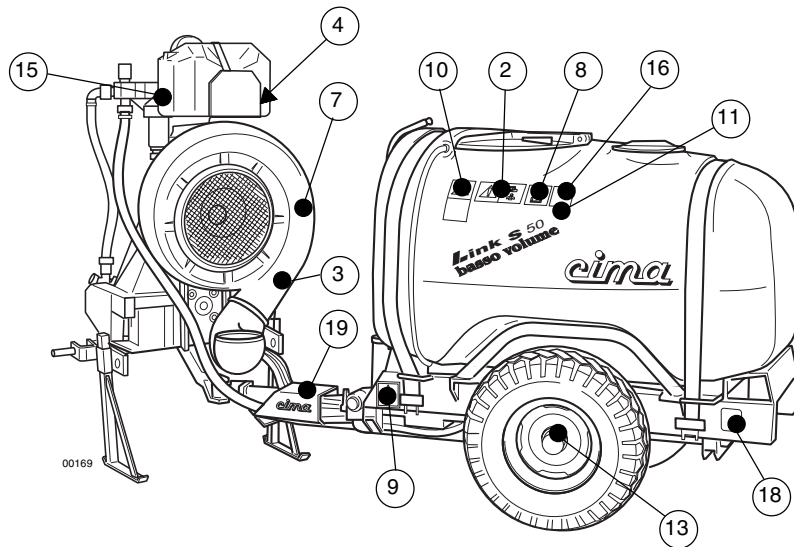
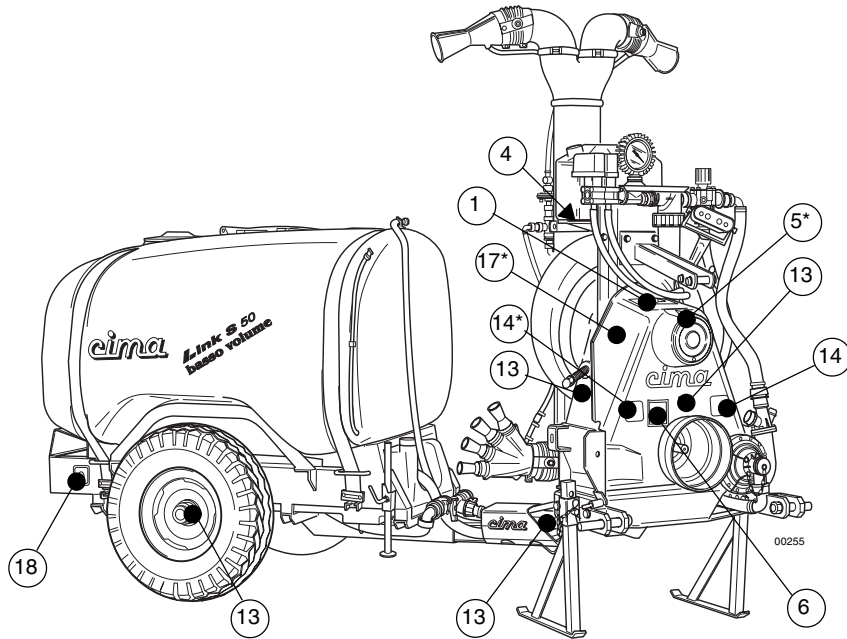

NOTE: The numbers with the asterisk (*) indicate the adhesives relevant either to optional components or to accessories to be applied **ONLY** on the models and versions on which this is foreseen.

00198

13.5 - PURGING OF RESIDUES FROM FILTER (Version with mixer)

With the machine in operation and the taps of the manual (P8) or electrical (E7) distributor closed. Opening the tap of the filter (P6) (turn counter-clockwise the handle), the delivery flow will drag possible sludge to the bottom of the filter within the tank through the piping (T4) thus partially cleaning the filtering cartridge. Close the tap when the operation is complete



When the machine is in operation, check that the drain tap is closed before opening the main feeder.

13.6 - CLEANING OF THE FAN



It is advisable for the cleaning of the fan to be carried out at a C.I.M.A service point. Dirt accumulation or incrustations can unbalance the fan, inducing vibrations that could cause breakage

1. Remove the distribution device (head).
2. Remove the fastening collar (1), fixing the fan casing outlet orifice to the union elbow.
3. Remove the two collar (5) fastening bolts, fixing the fan casing to the rear cover.
4. Remove the collar (5), locking the fan casing to the rear cover.
5. Extract the fan casing (2).



The impeller hasn't to be disassembled.

6. Clean the impeller, by avoiding to use high pressure water jets: they can cause infiltrations into the fan shaft support and consequently damage the bearings.
7. Mount back the casing (2), by paying a particular attention to get it perfectly coupled with the rear cover.
8. Fasten the fan casing, with the collar (5), to the rear cover and with the collar (1) to the union elbow.
9. Mount back the distribution device (head).



Carefully tighten all the fastening collars' bolts..

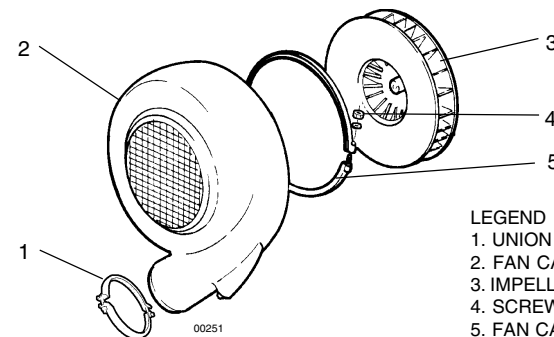

LEGEND

1. UNION ELBOW FASTENING COLLAR
2. FAN CASING
3. IMPELLER
4. SCREW NUT
5. FAN CASING FASTENING COLLAR

00251

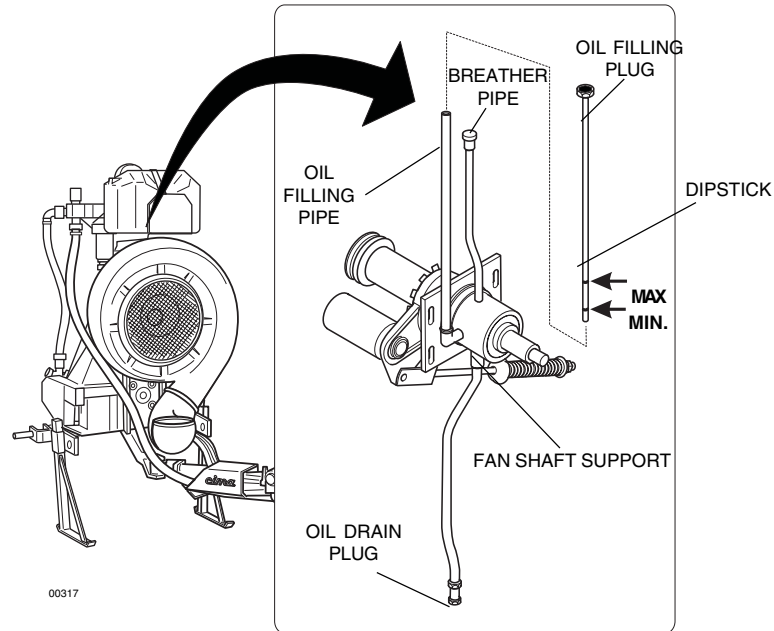

- Through the filling pipe, pour a SAE 90 oil proper quantity, up to reach the MAX notch on the dipstick:
 - about 0,10 kg for the 45 model
 - about 0,18 kg for the 50 model.
- Position again the plug with the dipstick and close the oil filling pipe.

13.4 - CLEANING OF FILTER'S CARTRIDGE

- Set the lever of 3-way tap (P3) to the "B" position.
- Completely close the pressure regulator (P5), by turning the handle clockwise.
- Close the manual distributor's taps (P8), or electrical (E7).
- Extract the cartridge: clean the grill and the retaining "O" Ring.
- Reassemble the cartridge and secure the lid with the thumb screw. Pay attention to the assembling of the lid's "O" Ring as the incorrect sealing of the filter will jeopardise the proper operation of the sprayer and cause loss of the mixture.

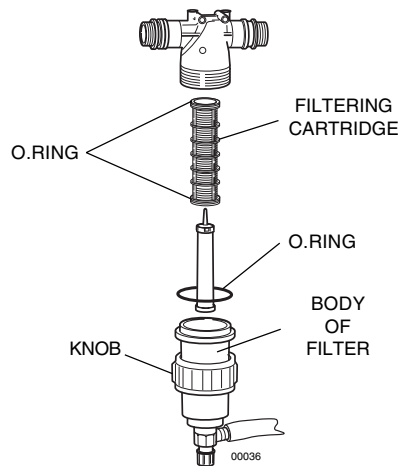

* Safety decals

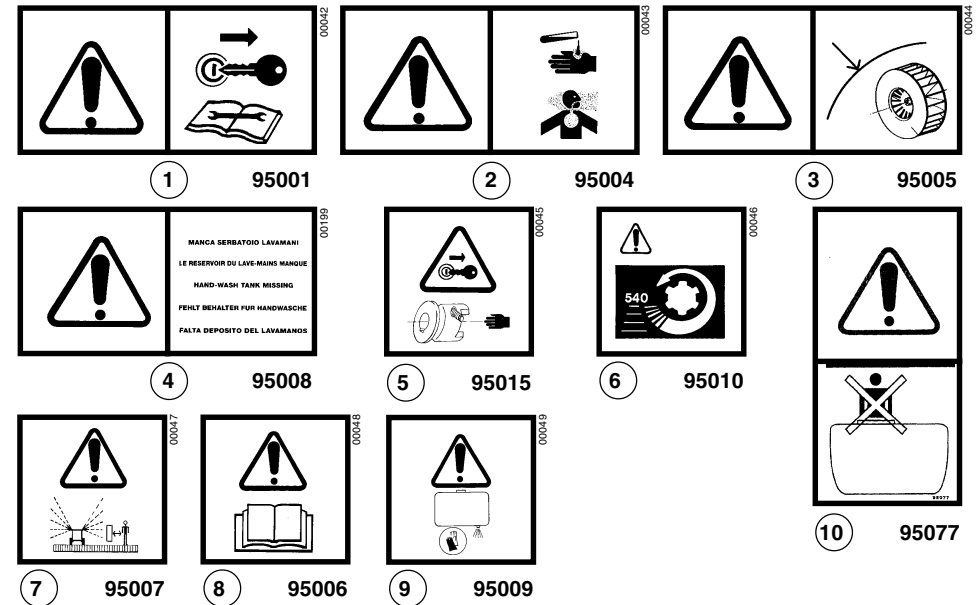

* Use and maintenance decals

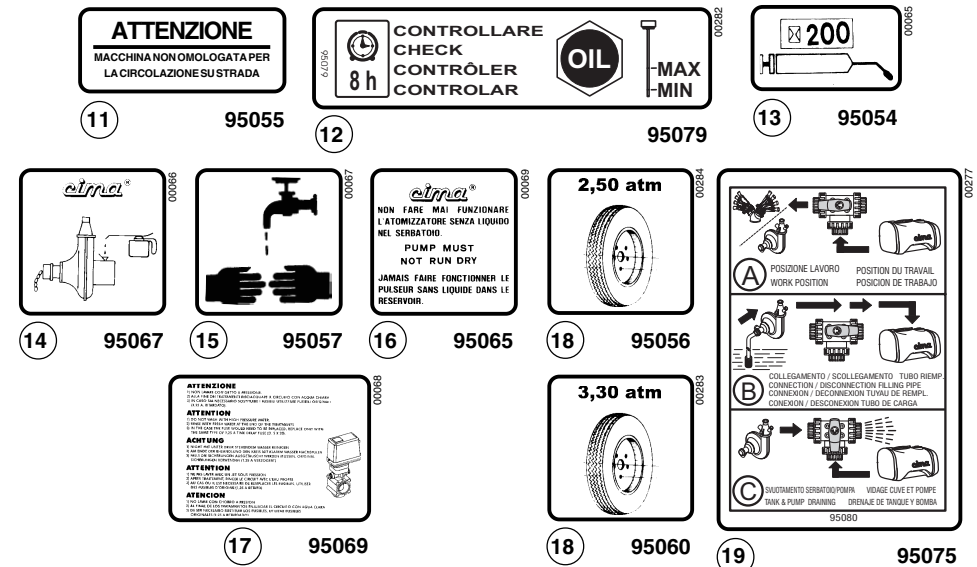

3 GENERAL INFORMATION 3

3.1 - MACHINE IDENTIFICATION

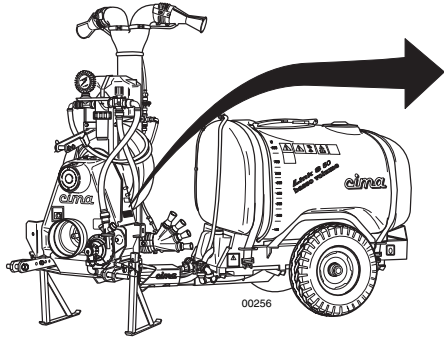

Identification nameplate

3.2 - TECHNICAL ASSISTANCE

C.I.M.A. S.p.A. is at the complete disposal of customers for any type of intervention. The names and addresses of its service network, both in Italy and in foreign countries, can be requested from:

C.I.M.A. S.p.A. - 27040 Montù Beccaria - Loc. Molino Quaroni (PV) - ITALIA
 tel. 0385-246636 - fax 0385-246637
 from abroad tel. +39-0385-246636 - fax +39-0385-246637
 e.mail tecnic@cimaitalia.com

3.3 - SAFETY NOTICES

All the preparation, use, maintenance, moving and transporting operations must be carried out only after having acquired a perfect knowledge of the regulations contained in this publication and the ability to appropriately interpret the symbols of the decals applied to the machine.



IT IS FORBIDDEN TO UTILISE THE SPRAYER FOR PURPOSES OTHER THAN FOR ITS INTENDED USE, SINCE IT WAS MANUFACTURED ONLY FOR SPRAYING AGRICULTURAL CROPS WITH ANTI-PARASITIC PRODUCTS.

It is necessary to scrupulously abide by the following general norms:

- always stop the tractor's engine before carrying out any operation on the sprayer;
 - check that the weight and power of the tractor are compatible with the sprayer to be used;
 - before utilisation, check the correct tightening and securing of the machine's various components, paying particular attention to the safety protections and to the moving parts;
 - only utilise protected cardan shafts provided with CE conformity certification.
- Carry out the assembly only if the drive outlets of both tractor and sprayer are equipped with the protection counter-guard;
- check that the cardan shaft is blocked by the appropriate anti-rotation chains;
 - keep people and animals away from the machine before starting it up;

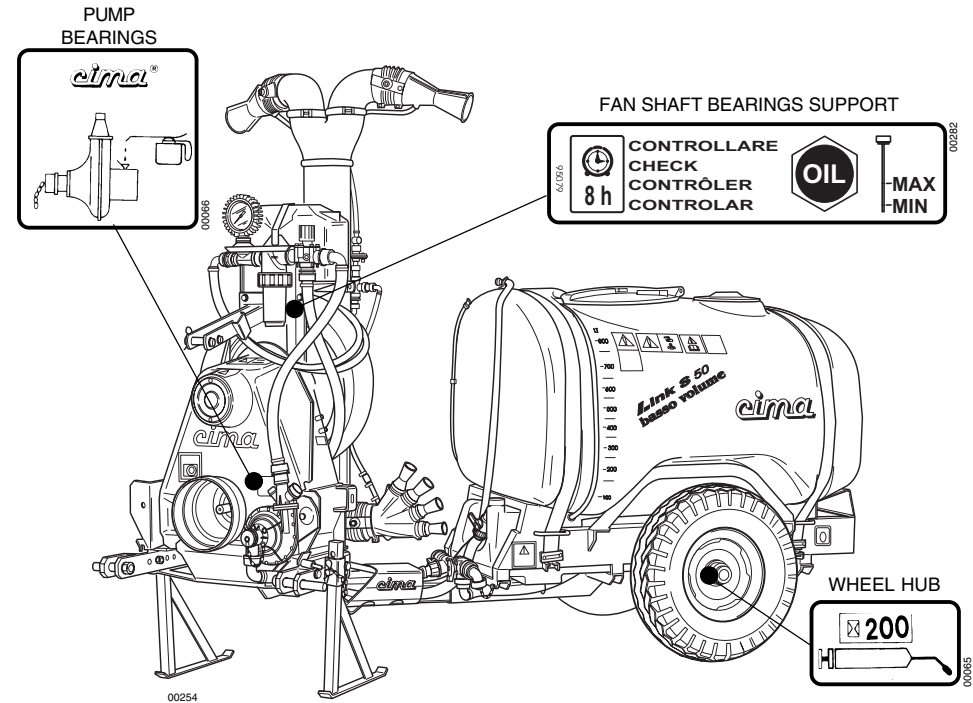

13.2 - FAN SHAFT SUPPORT OIL LEVEL CHECK

1. Unscrew and remove the oil filling plug with the dipstick.
2. Clean the dipstick and introduce it again.
3. Extract the dipstick and check the oil level, which has to be between the two minimum and maximum level notches of the dipstick itself.
Should it be necessary to top up the level, add some SAE 90 oil, up to reach the dipstick upper notch (MAX).
4. Introduce and screw the oil filling plug with the dipstick.

13.3 - FAN SHAFT SUPPORT OIL REPLACEMENT



Let the fan support oil replacement intervention be carried out at a C.I.M.A. customers' service centre.

1. Unscrew and remove the oil filling plug with the dipstick.
2. Remove the oil drain plug and let the oil completely flow out from the fan shaft support.
3. Check the oil drain plug and the relevant seal for integrity, replace them, if necessary, and close again the oil drain plug.

13 MAINTENANCE OPERATIONS 13

⚠ ALL OPERATIONS MUST BE CARRIED OUT WITH THE ENGINE SWITCHED OFF AND WITH THE IGNITION KEY REMOVED FROM THE CONTROL PANEL.

13.1 - LUBRICATION

Maintenance point	Action	Consumption material	Periodicity
Fan shaft bearings support	Check oil	Oil SAE 90	8 hours
Fan belt-tensioner support	Greasing	Grease Type EP Classe NLGI 2	200 hours
Pump bearings	Oiling	Engine oil	6 months
Free wheel	Greasing	Grease Type EP Classe NLGI 2	200 hours
Wheel hubs	Greasing	Grease Type EP Classe NLGI 2	200 hours
Frame articulated joint	Greasing	Grease Type EP Classe NLGI 2	200 hours
Fan shaft bearing support	Change oil	Oil SAE 90	Yearly

👁 Carefully clean the greasing nipples and the oil filler in order to avoid that, during lubrication, dirt might be introduced.

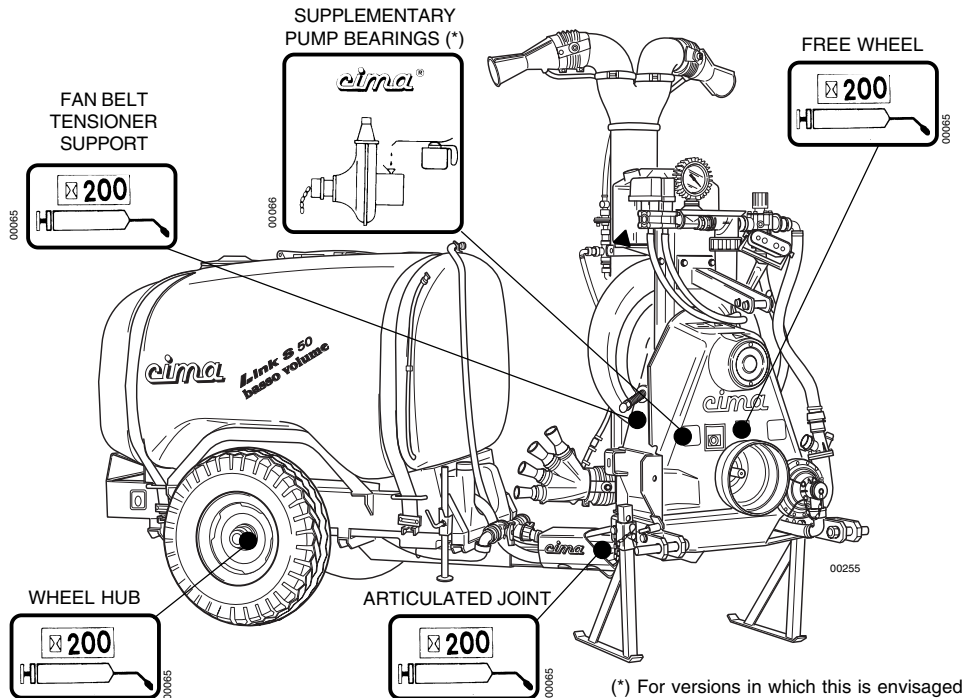

- don't wear articles of clothing that might get caught in moving parts;
- keep to a low speed while negotiating bumps or crossing ditches.

- ⚠**
- All maintenance and repair operations must be carried out only after having rinsed the tank and flushed the system.
 - Before operating within the tank it is necessary to wash it thoroughly with clean water.
 - It is forbidden to perform welding operations if ammonium salts were previously used.
 - It is forbidden to use the machine within a potentially explosive environment.
 - The application of paints and/or solvents, the washing of closed environments and machinery as well as the utilisation of the air flow for purposes other than those expressly concerning the spraying of agro-chemicals is not permitted.
 - It is forbidden to enter the tank.

3.4 - SAFETY SYSTEMS

All machine moving parts are suitably protected by guards and highlighted through the use of warning decals.

- ⚠**
- It is forbidden to use the machine with these guards removed.
 - Before removing the protection, stop the tractor's engine and remove the key from the control panel.

The pictures illustrate the machine's guarded parts:

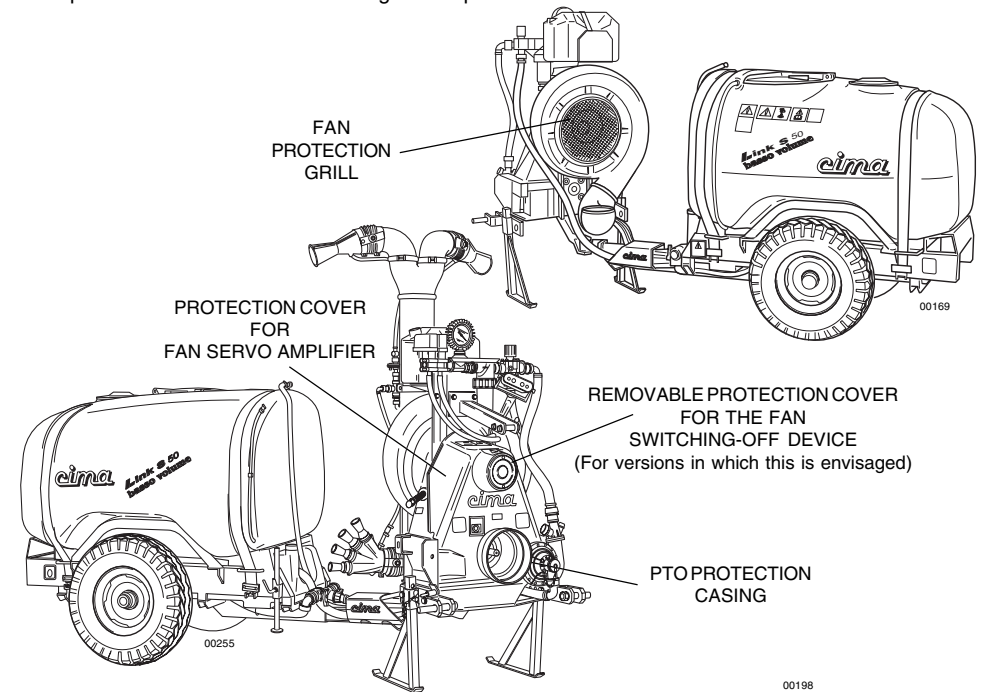



THE OWNER AND/OR THE OPERATOR OF THE SPRAYER ARE NOT PERMITTED TO MODIFY THE STRUCTURE OR THE SPECIFIC OPERATION OF THE SPRAYER ITSELF. ANY REPAIRING INTERVENTION HAS TO BE CARRIED OUT EITHER AT THE DISTRIBUTORS' OR AT THE C.I.M.A. S.p.A. AUTHORIZED WORKSHOPS, OTHERWISE ANY KIND OF WARRANTY IMMEDIATELY CEASES AND C.I.M.A. S.p.A. IS CLEARED OF ANY CONSEQUENT AND/OR IMPLIED RESPONSIBILITY.

3.5 - HANDLING OF AGRO-CHEMICALS

The **operator** could become contaminated due to accidental spray, contact or inhalation of products or crop-spraying mixtures.

The **environment** could become polluted by mixture over-spills, puncturing of containers, uncontrolled storage of used and unwashed containers or spillage into waterworks.

In order to avoid these risks the preparation and filling operations must be carried out in suitably appointed and adequately equipped sites.

3.5.1 - Storage

Fixed / stationary: the site used must be well ventilated and secured by lockable doors in order to prevent even accidental access by children or unauthorised persons.

Mobile: the carrier equipment must be properly locked and kept under conditions whereby access by children or unauthorised persons can be prevented during the absence of the operator. All full or partially utilised containers must be secured against tipping, falling or breakage during transportation.

Both types of storage must:

- have a suitable container for the storing of empty packaging materials should a specific storage area not be available;
- have a clean water supply readily available for washing, by means of a specific container or through connection to the waterworks system;
- have the use of fire extinguishers, should flammable products and substances be stored.



All packages, whether whole or partially utilised, must be stored in their original packing and with the warning instructions clearly displayed and legible.
The storage indications must always be scrupulously adhered to, as well as their utilisation and possible disposal as suggested on the product's original packaging.

3.5.2 - Specific equipment

The site at which the preparation and filling out will take place must provide for:

- all the equipment necessary to the precise measuring of both the water quantity and the dose of product to be mixed in the tank at every filling;
- all the equipment and means useful to the preparation of the mixture and for the cleaning of the operator in case of contamination;
- all tools necessary to facilitate the direct introduction of the agro-chemicals in the tank;
- the allocation of clothing and specific equipment in order to avoid contamination by contact or inhalation during the whole operative phase of the intervention;
- the availability of proper equipment able to stop the uncontrolled spilling and flowing of the mixture;
- a retaining valve on the feed pipe when the filling of the tank takes place directly from the waterworks system.



NO TRAILER-MOUNTED SPRAYER IS HOMOLOGATED FOR CIRCULATING ON ROAD
 THE FOLLOWING ACTIONS ARE NOT ALLOWED:

- Transporting the sprayer with residual quantities of mixture in the tank.
- The transporting of people, animals or things.
- The trailing of vehicles or equipment.



Road transport must take place in the complete observance of road regulations in force in the Country where the machine is used.

The operator is responsible for possible defaults due to the non observance of said regulations.

• Transport of the sprayer



Before carrying out any operation it is essential to verify that no mixture residues are left in the tank.

1. Check that the cables or chains used for the lifting are adequate for the weight to be lifted (machine – distribution devices - accessories).
2. Hook the winch cable of the transport vehicle (or of an other suitable towing mean) to the lower forks and to the upper arm for the coupling to the hoisting device, in order to make sure that the towing force parallel to the ground and to the transport mean plane is fully applied.
3. Hoist the sprayer on the transport mean, towing it with a careful and constant movement.

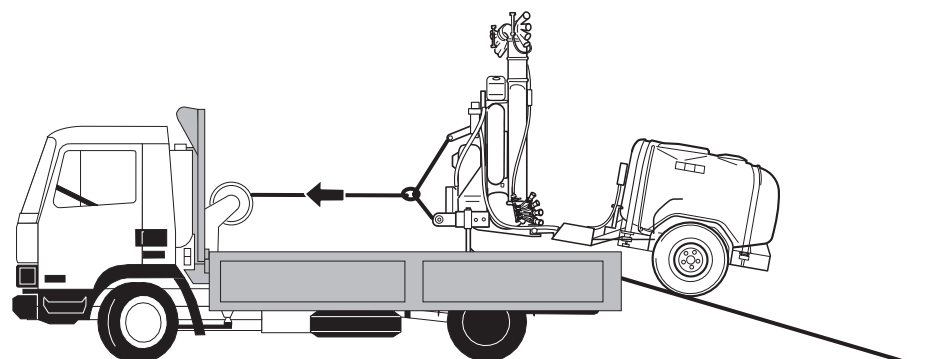

00289

4. Position the sprayer on the transporting vehicle in perfectly stable conditions.
5. During transport the machine must be immobilised and fastened to the carrier by way of suitable strapping.

- d. Clean out the filter cartridge.
- e. Keep the machine in a ventilated place, sheltered from rain or sun: sunrays are the worst enemies of plastic and rubber parts.

11.4.2 - End of seasonal cycle

- **The operator must:**
 - a. Take the utmost care in carrying out the operations envisaged at the end of the daily treatments: the cleaning of the hydraulic circuit must be done at least twice. Check that no product residues are left in any part of the circuit.
 - b. Lubricate all the greasing points, replace the fan support oil, then let the atomizer operate for some minutes.



THE PUMP HAS NEVER TO DRY-OPERATE.

- c. Completely drain the hydraulic circuit, paying a special attention to the centrifugal pump; in order to completely drain the pump, remove the draining plug, which is mounted on the pump itself.

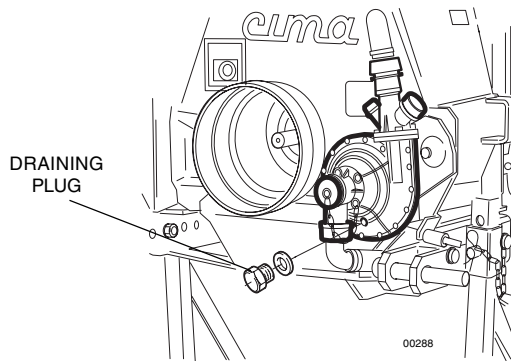

Avoid using anti-freeze solutions.

- d. Check the proper operation of all parts and of the machine structure. In case of faults being detected, request the intervention of one of our service points.
- e. Keep the machine in a well ventilated place, sheltered from rain, icing and direct sun rays.



The use of detergent products for the cleaning operations is allowed only in the observance of the regulations in force. For these, the operator must gather the relevant information from the specifically appointed bodies ruling on this subject.

3.5.3 - Disposal of empty containers and agro-chemicals residues

Agro-chemicals are classified as "special" waste and their disposal must take place separately from "urban" wastes.



Empty packaging and contaminated containers to be done away with cannot be dispersed, burned or buried.

The washing water for the cisterns and the tools utilised for the preparation of mixtures cannot be emptied on the ground, spilled into the sewage system or in waterways and rivers.

The disposal of special wastes is regulated by specific norms. In order to perform this operation it is necessary to obtain the relevant information from the Local Offices specifically appointed to rule on this subject. The non compliance with these regulations can cause considerable damage to persons and animals as well as polluting the environment.

3.5.4 - Personal means of protection

The toxicity of agro-chemicals forces persons working with them to wear adequate protective clothing and accessories in order to avoid risks of contamination by contact or inhalation.

In each of the following work stages:

- filling of tanks and adding of the agro-chemical,
- dusting and spraying,
- adjusting of the sprayer,
- emptying and cleaning of the tank,
- replacement of the agro-chemical,
- maintenance interventions,

it is necessary to wear personal protection clothing and accessories.

The following must be worn:

- Polyethylene or polyvinyl gloves.
 - Full, waterproof cotton overalls, in order to guarantee transpiration, fitted with polypropylene side flaps.
- In commerce, one-time 'tyvek' overalls are available which, after use (see picture), must be disposed of according to the modalities applicable to toxic waste.

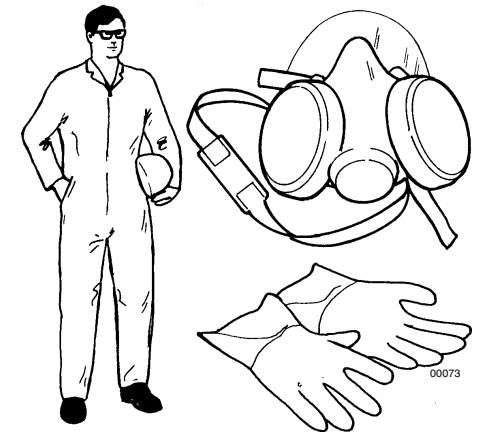

- A protective half-mask in polychloroprene rubber with 1 or 2 filters. Filters for gases and organic fumes, of European A1-class vapours, are envisaged and these can be combined with anti-dust models of P1 European class, for harmful mists and powders, or P2, for harmful and toxic mists and powders.



The filters must be replaced:

- when the smell/taste of agro-chemicals can be detected, and that of active A1-class carbons;
 - when difficulty in breathing is experienced for the anti-dust filters of class P1 and P2.
- In any case it is necessary to make use of all personal means of protection as suggested by the manufacturers.**

The pictures indicate the position of the main components of the sprayer.

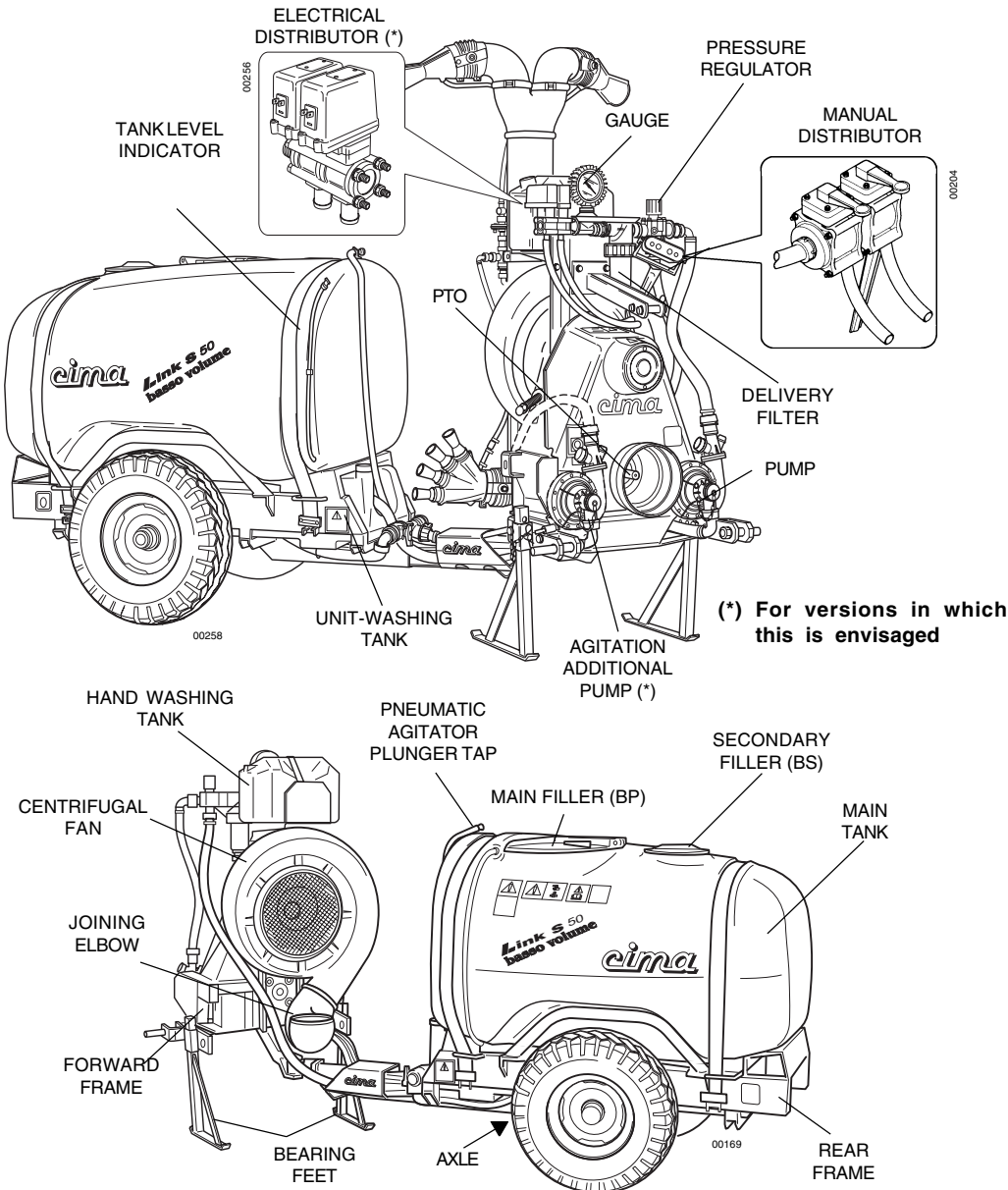

11.3 - THE TREATMENT



IT IS ADVISABLE TO BEGIN TREATMENT AT THE HEADLANDS..

- **The operator must:**
 - a. shake the mixture in the tank before starting the treatment, re-circulating it completely for as long as it takes to make it homogeneous.
 - b. continue to shake the mixture until the treatment is resumed should the intervention momentarily be interrupted. If the utilisation is to be deferred, check that the filter cartridge is clean before resuming and **agitate the mixture** that has remained in the tank.
 - c. ensure that the hand wash supplementary tank is filled with clean water after each filling operation.
 - d. make use of individual protections identical to those envisaged for the preparation of mixtures if the tractor is not equipped with a pressurised cabin with aeration filters.
 - e. wash immediately all the elements that might have become contaminated during the treatment, promptly remove the polluted garments and **interrupt the work if these cannot be immediately replaced.**
 - g. keep to the preliminary operations already indicated (11.1.c), in case of wind conditions prevailing.
 - h. stop the engine, remove the key from the tractor's control panel.
 - i. pay particular attention to the treatment when close to boundaries and in proximity of dwellings, waterways, roads or public-usage paths.

11.4 - END OF TREATMENT - STORAGE

11.4.1 - Daily

- **The operator must:**
 - a. Wash the machine's exterior before cleaning out the hydraulic circuit. The operative sequence will permit the elimination of possible water residues from the fan casing and piping conveying the air flow to the heads.



The washing of the sprayer's exterior must be carried out in an area in which foul waters are collected in a disposal pit. DO NOT UTILISE HIGH-PRESSURE HYDRO-CLEANERS.

- b. Carry out the cleaning of the hydraulic circuit by washing the inner side of the tank with a clean water jet, then spraying it on the crop on which the treatment has just been completed: if necessary repeat this operation.
- c. Check the efficiency of the distribution device (head) and the cleaning of the pulverising points (diffusers), possibly replacing them if found to be damaged.

- IL SERRAGGIO DELLE VITI E DEI BULLONI DI FISSAGGIO DI TIMONE, ASSALE, MOZZI ERUOTE;
- LA TENSIONE DELLE FASCE DI FISSAGGIO DEL SERBATOIO PRINCIPALE;
- LA PRESSIONE DEI PNEUMATICI.

- The operator must:
 - a. Wear adequate protective clothing and accessories such as overalls, waterproof suits, gloves, glasses and masks to shield him from contamination by inhalation or contact with the products handled.
 - b. With the parameters defined during the preliminary operations, carry out the adjustments of the sprayer.
 - c. Prepare the mixtures in a well ventilated area. When in the open, the presence of wind increases the danger of contamination.
 - d. Precisely weigh the previously calculated doses of products to be mixed at every filling operation.
 - e. Avoid handling products close to open flames, embers, incandescent bodies or in the presence of flammable substances.
 - f. In order to obtain the correct volume dosage of agro-chemicals and fertiliser mixtures, the fertiliser must be first diluted.
 - g. Wash and rinse the just emptied product containers with clean water – collect the washing water and pour it in the tank before carrying out the filling – place the empty packaging in the specific container or in the collection area.
 - h. Wash the equipment and tools utilised in the preparation and place them in the chemical products storage area.
 - i. **Always** leave the area assigned to the loading and preparation of the mixtures in such condition as to avoid **any** possibility of contamination to persons or animals or of pollution to the environment.
 - l. If necessary, mark the field or the area of machine passes in order to provide a guide for the treatment and avoid missing or double-treating coverage areas.



• **AT THE END OF THE OPERATIONS NECESSARY FOR CARRYING OUT THE INTERVENTION, THE LOCATION-STORAGE AREAS MUST BE LEFT IN THE CONDITION REQUIRED FOR THE CARRYING OUT OF THEIR PREVENTION AND PROTECTION FUNCTIONS.**

• **BEFORE STARTING THE TRACTOR, KEEP AWAY PERSONS OR ANIMALS AND NEVER LEAVE IT UNATTENDED DURING THE PREPARATION OPERATION.**

4.1 FRAME

The LINK trailer-mounted sprayer frame consists of two sections: the front section, supporting the fan-servo amplifier unit, and the rear one, supporting the tank.

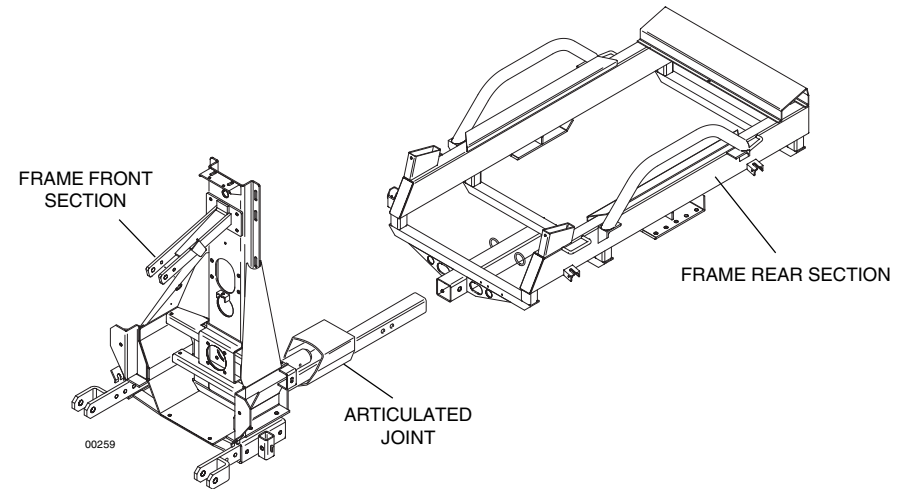

The connection between the frame two sections is realized by means of a special articulated joint, which is integral with the frame front section and assures a completely free movement to both the frame sections.

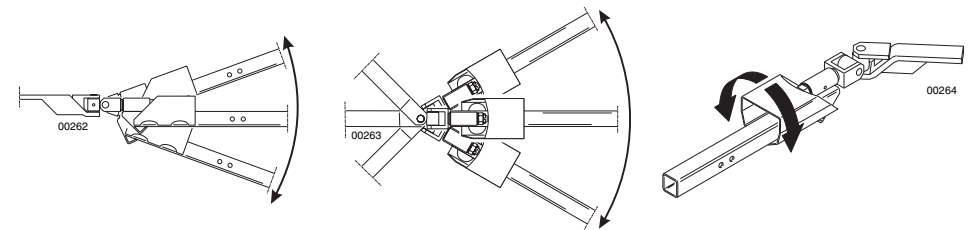

The front section is directly coupled with the three points-hydraulic hoisting device of the tractor. **The Blitz 45 range frames** can be coupled with the hydraulic hoisting devices of class “1”. The piston pins’ diameter measures 22 mm. The third point pin diameter measures 19 mm.

The Blitz 50 range frames can be coupled with the hydraulic hoisting devices of class “2”. The piston pins’ diameter measures 28,5 mm. The third point pin diameter measures 25 mm.

As it is possible to regulate the length of the coupling lower bars to the hydraulic hoisting device, the length of the coupling between the frame front and rear sections, the trailer axle and the track positions, the sprayer articulated joint can be exactly positioned **on half a way between the tractor rear axle and the trailer one**. On that condition, the trailer wheels exactly cover the same trajectory as the tractor wheels.

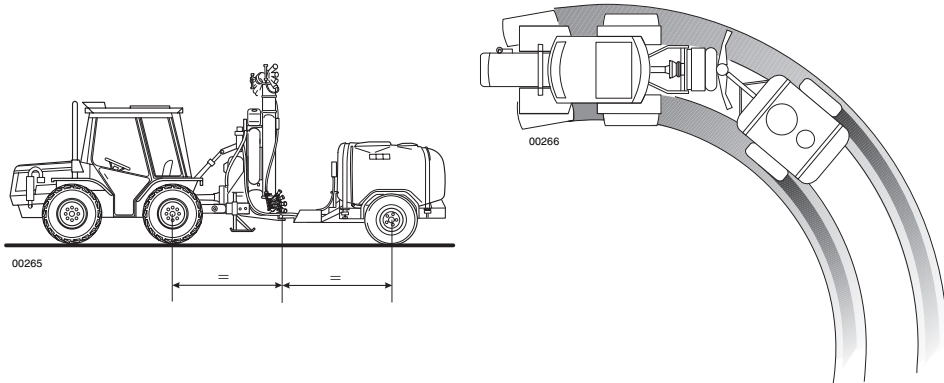

HOISTING DEVICE COUPLING LOWER FORKS

They are inserted in the articulated frame front section. Their position is regulated through the two lateral bolts, especially foreseen for this purpose. The forks can moreover be turned, in order to modify the hoisting device lower coupling width.

- To be length-regulated, by 5 – 10 cm. displacements.



After every regulation, carefully tighten all the screws and the bolts concerned by the intervention.

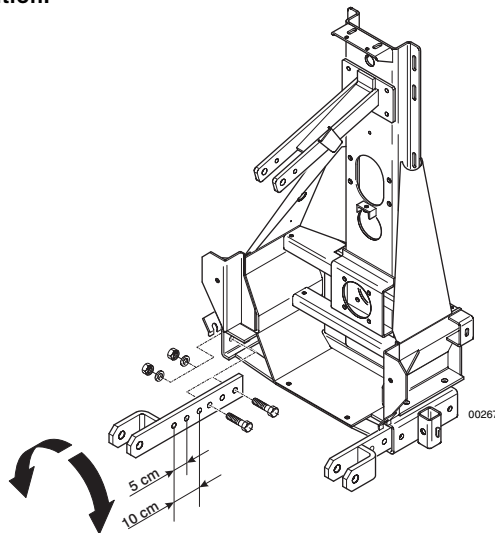

11.1 - PRELIMINARY OPERATIONS TO TREATMENT

- The operator must:
 - a. Ascertain that the condition of the crops, the progress of the disease or the need for its prevention actually justify the treatment to be applied.
 - b. Be aware of the meteorological conditions forecast for all the time necessary for carrying out the treatment.
 - c. If possible, avoid carrying out the spraying in strong wind conditions or when one detects that the sprayed mixture disperses away from the target crop (drifting). It is advisable to suspend the treatment when the wind speed exceeds 3 m/s (10 km/hour). Should it be imperative to operate anyway, the following suggestions are made:
 - reduce the distance of the target from the spraying points, even if detrimental to the quality of the spraying
 - increase the dimension of the droplets, suitably adjusting the machine.
 - d. Check that multiple-product mixtures be physically, chemically and biologically compatible amongst themselves; if need be, obtain the necessary information from the products' sales representative.
 - e. Carefully calculate the exact quantity of the product necessary for the treatment and establish the volume of water to be used for the intervention.
 - f. Check that the product is available in a quantity sufficient to complete the intervention.
 - g. Read the product's utilisation instructions carefully, in order to ascertain the usage conditions, the correct dosage and the expiration dates.
 - h. Make sure of the parameters necessary to the adjustments of the machine and determine the exact dose of product to be applied to every loading. Follow the instructions of the publication titled "Instructions for the machine's adjustments – Suggestions and considerations on the low-volume treatments" as well as those contained in the use and maintenance book-let of the distribution device.

11.2 - PREPARATORY OPERATIONS TO TREATMENT



THE FILLING MUST BE CARRIED OUT WITH THE MACHINE ON A FLAT SURFACE. BEFORE THE OPERATION, IN THE ALLOCATED AREA, THE DOSES OR MIXTURES TO BE POURED IN THE TANK MUST BE MADE READY.

Before starting the filling cycle, check:

- the EFFICIENCY of the Distribution device (HEAD);
- that the SPRAYING POINTS (DIFFUSERS) ARE CLEAN;
- that the CARTRIDGE AND THE DELIVERY FILTER (P6) ARE CLEAN

The **hydraulic** and the **pneumatic** circuits mounted inside the tank, allow to realize a **double agitation system**: with the pump water and with the fan air, **at the same time**. The pneumatic circuit can be excluded, when the products used have a quite strong foaming effect, by closing the piston cock, mounted over the tank. When that cock is opened again, check that the air outlet holes aren't obstructed.



It is advised however to also use always the pneumatic agitator, adding to the mixture, if necessary, a antifoam product.



Before starting the treatment it is essential to agitate the mixture in the tank, recirculating it completely for as long as it takes to make it homogeneous.



The agitation has to be carried out with the pressure regulator (P5) completely open. Also the cock of the pneumatic regulator has to be open. This operation is of main importance, in order to get a uniform distribution of the active principle on the whole vegetative surface to be treated.

Should the activity need to be interrupted during a treatment with the sprayer, keep the agitator activated until the treatment is resumed. Should this be stopped and deferred to a later stage, the mixture that has remained in the tank must be **agitated again** properly.

THE MIXTURE AGITATION HAS TO BE CARRIED OUT WITH THE POWER TAKEOFF RUNNING AT A RATE OF AT LEAST 500 RPM.

10 TANK AND HYDRAULIC CIRCUIT DRAINING



- Stop the tractor and remove the key from the control panel.
- Wear suitable protective clothing and accessories in order to avoid contamination by contact or inhalation of the mixture.
- Carry out the discharging in a suitable and properly geared area for the collection of the washing liquid.

This operation has to be carried out with the 3-way cock P3:

1. Position the lever of the 3-way cock (P3) to "A" (draining closed).
2. Unscrew the drainage plug.
3. Turn the lever to position "B" (draining open).
4. When the draining is completed, position again the lever of the 3-way cock (P3) to "a" (draining closed), and screw again the chain plug.

AXLE

The axle is secured to the frame rear section by means of especially foreseen screws, allowing to regulate its position, in order to modify the sprayer trailer wheel base. The five holes machined on the fastening plate allow to select three different axle positions, by 5,75 cm displacements.

The wheels' axle shafts, inserted in the frame axle and locked by some special screws, allow to regulate the track width, in order to fit it to the intervention requirements.

- The height with respect to the ground can be regulated. (The misalignment between the axle shaft and the wheels' hub allows a variation of 12 cm). It is enough to turn the axle shafts.



After every regulation, carefully tighten all the screws and the bolts concerned by the intervention.

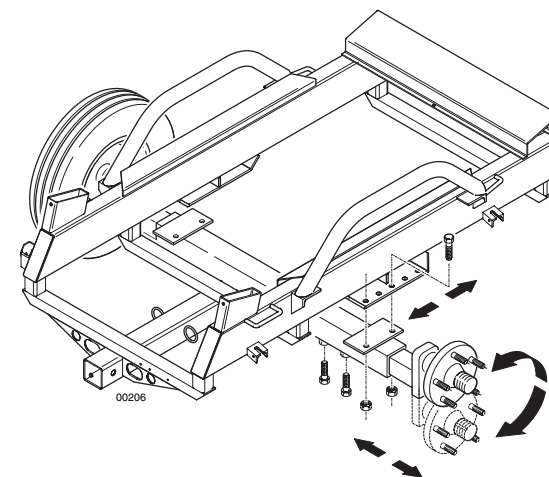

WHEELS. The wheels' hubs are equipped with grease nipples for the bearings lubrication (see 14.1). The tyres' size and the operating pressure are indicated at step 4.5.2.

BEARING FEET. They assure stability to the unit, when it isn't coupled to the tractor.



The sprayer **HAS NEVER** to be uncoupled from the tractor before having correctly positioned the bearing feet.



The **BEARING FEET** have always to be locked on "treatment position" during the unit operation.

The bearing feet can be fastened to the sprayer in 2 different positions, according with the different operational requirements:

Position A - front feet downwards and rear foot lowered: **THIS ALLOWS TO UNCOUPLE the tractor** and assures the sprayer stability, when it isn't coupled to the same one.

Position B - front feet vertically applied to the frame and rear foot lifted: it allows to use the sprayer, after that the same one was coupled to the tractor (**treatment position**).

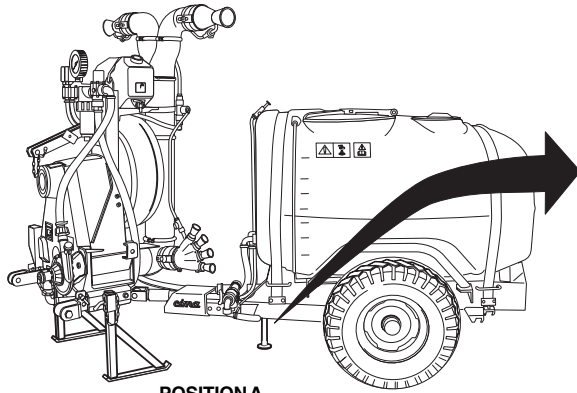

00270

POSITIONA
STATIONARY
POSITION

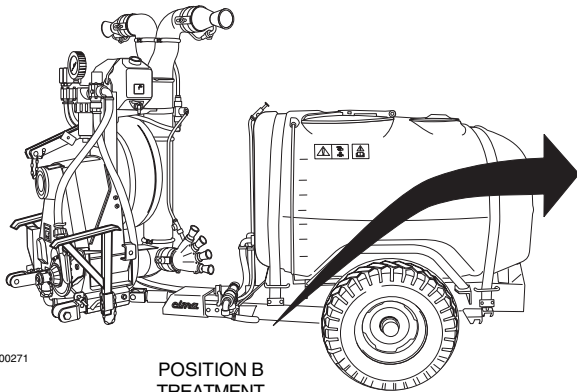
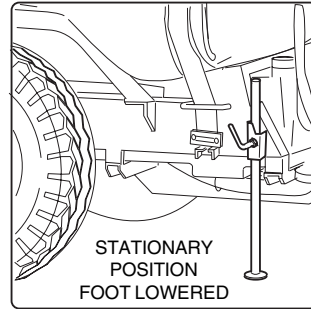

00271

POSITION B
TREATMENT

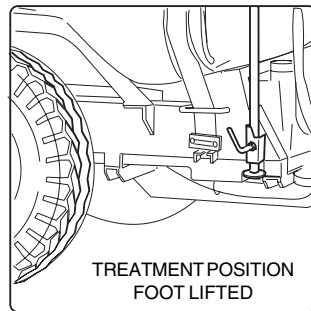

THE RESPONSIBILITY OF THE REGULATION, ASSEMBLY AND DISASSEMBLY OPERATIONS OF THE HOISTING DEVICE COUPLING FORKS, OF THE AXLE AND OF THE WHEELS IS CHARGED TO THE OPERATOR, WHO HAS BOTH TO REALIZE AND TO ASSURE THE NECESSARY SAFETY CONDITIONS, IN ORDER TO PREVENT ANY POSSIBLE ACCIDENT.

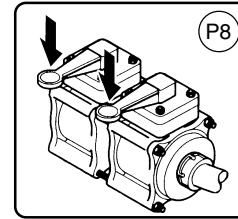

00093

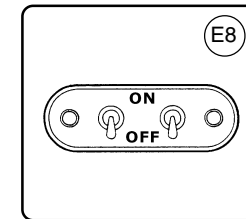

00094

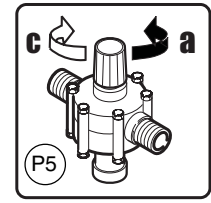

00240

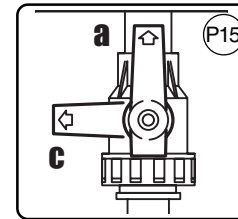

00315

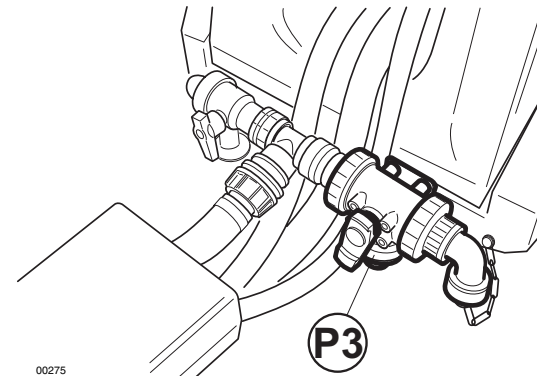

00275

A	POSIZIONE LAVORO WORK POSITION	POSITION DU TRAVAIL POSICION DE TRABAJO
B	COLLEGAMENTO / SCOLLEGAMENTO TUBO RIEMP. CONNECTION / DISCONNECTION FILLING PIPE CONEXION / DECONEXION TUYAU DE REMPL. CONEXION / DESCONEXION TUBO DE CARGA	
C	SVUOTAMENTO SERBATOIO/POMPA TANK & PUMP DRAINING	VIDAGE CUVE ET POMPE DRENAJE DE TANQUE Y BOMBA

95080

00277

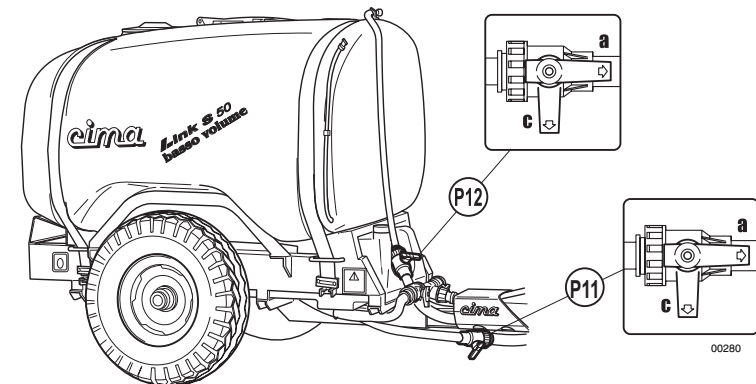

00280

12. Pour into the tank about 15/20 litres of water: this quantity has to be enough TO FILL the pipe and TO PRIME the pump (P4).
13. Start the tractor and engage the PTO; then bring it up to a 500 r.p.m. rotation rate.
14. When the pump will have started the recycling of the poured water, close the cock (P3), by positioning the lever to "B", in order to start the filling through the return pipe (T3).

15a. WITH MEDICINE MIXTURES OR LIQUID PRODUCTS (WHEN NOT USING THE MIXER)

- 15a1. Pour the medicine mixture foreseen for every loading (and the possible washing water for the medicine packs and for the instruments used for preparing the mixture) into the main filler (BP).
- 15a2. Close the main filler (BP) of the tank and wait until the filling is completed.

15b. WITH POWDER PRODUCTS, WHEN USING THE MIXER (IF FORESEEN)

- 15b1. Pour the powder medicine dose into the cup-like filter of the main filler (BP).
- 15b2. Close the main filler (BP) and the secondary filler (BS) of the tank.
- 15b3. Open the cock (P15) of the mixer and wait until the filling is completed.
- 15b4. Close the cock (P15) of the mixer.
16. Disengage the PTO.
17. Completely close the pressure regulator (P5), by turning the handle clockwise.
18. Remove the filling pipes from the pump (P4) and position again the closing plug.
19. Completely open the pressure regulator (P5), by turning the handle anti-clockwise.
20. Position the lever of the 3-way cock (P3) to "A".
21. Engage the Power Takeoff and move to the treatment place, keeping the Power Takeoff running rate **at least 500 RPM during all the way.**

IN THE AREA OF THE TREATMENT:

22. Disengage the power take off (PTO).
23.   **STOP THE TRACTOR AND REMOVE THE KEY FROM THE CONTROL PANEL.**
24. Make sure that the fan is stopped. Hook the fan to the servo amplifier as indicated at point 8.1.b.

 **Properly tighten the screw nut securing the mobile protection cover.**

25. Start the tractor.
26. Engage the Power Takeoff and set it up to a running rate of at least 500 r.p.m., **in order to carry out a further agitation.**
27. CARRY OUT THE TREATMENT.

4.2 - FAN SERVO AMPLIFIER

It is positioned in the unit front section and protected by a plastic casing.

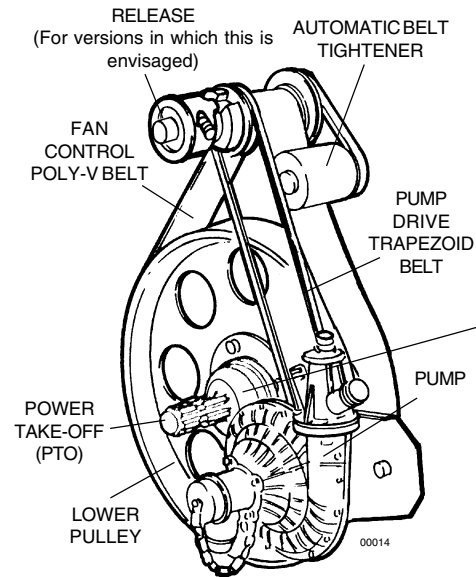

Servo amplifier

A free-wheeling gear is included between the Power Take-off of the servo amplifier and the fan control pulley (refer to the picture). In case of sudden decelerations or unexpected engine stoppage, this allows the fan to continue its free rotation, thus avoiding extreme mechanical stresses to be transmitted to the drive members.

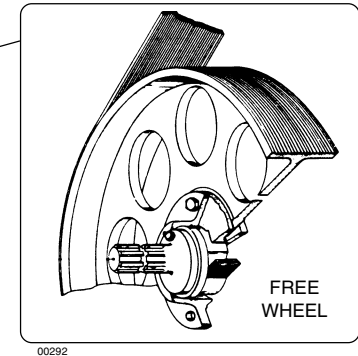

Centrifugal fan

The front-engaging clutch assembled on the fan shaft allows the operation of the centrifugal pump without the fan. (for versions in which this is envisaged). An air intake, pre-set on the outer edge of the housing, is connected to the plunger tap placed above the tank. Through this tap it is possible to carry out or exclude pneumatic agitation. The closed blades' impeller is sheet steel realized and dynamically balanced; the air intake opening on the casing is protected by a grating, especially foreseen for this purpose.

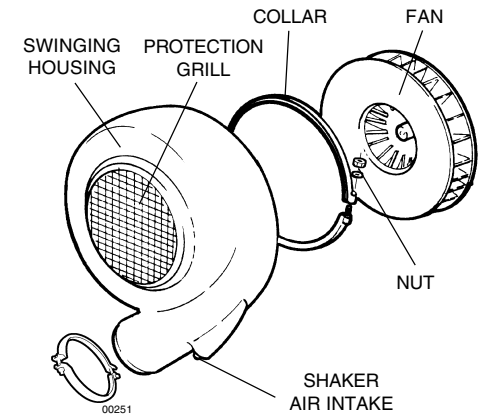

4.3 – HYDRAULIC CIRCUIT COMPONENTS

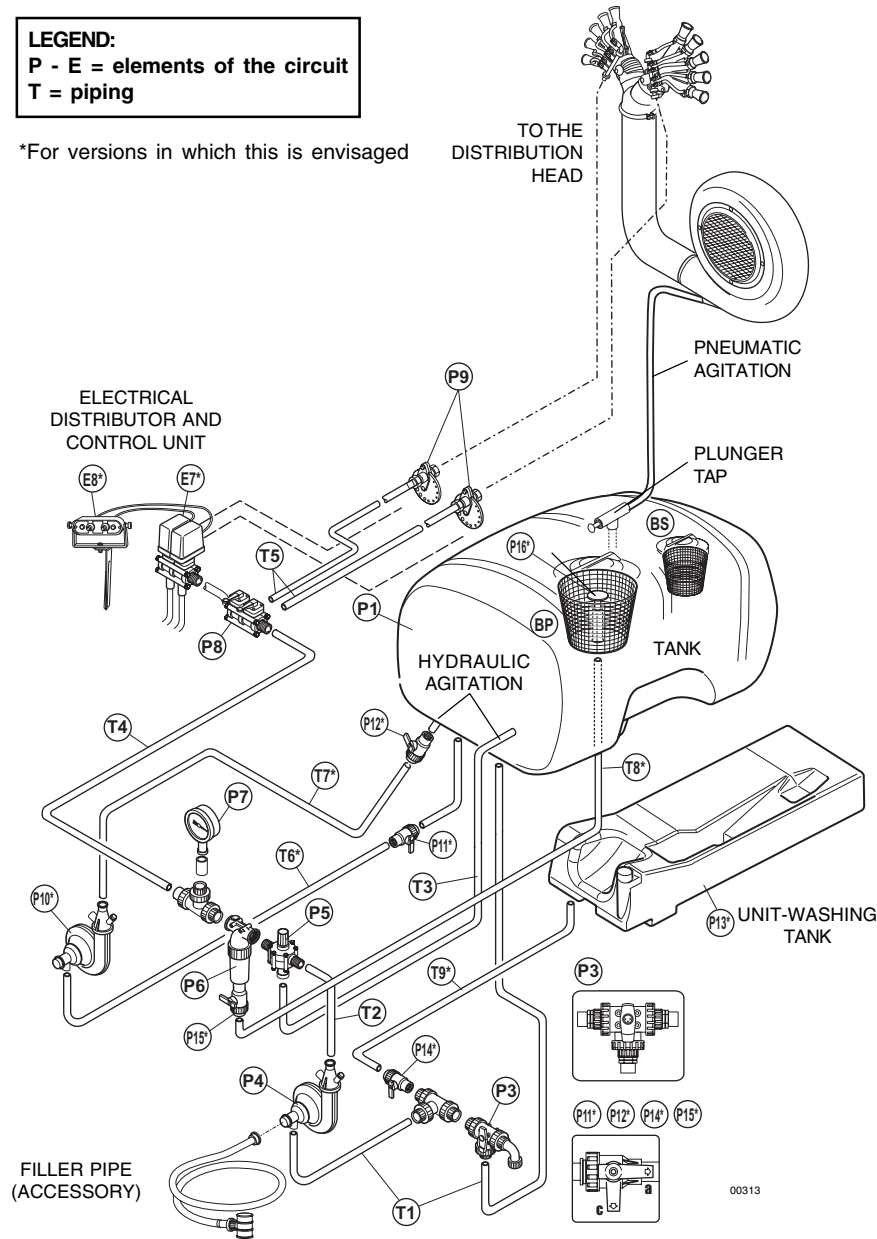

LEGEND:
P - E = elements of the circuit
T = piping

*For versions in which this is envisaged



- 9b1. Pour the powder medicine dose into the cup-like filter of the main filler (BP).
- 9b2. Close the main filler (BP) of the tank.
- 9b3. Open the cock (P15) of the mixer.
- 9b4. Complete the filling with water from the secondary filler (BS)
- 9b5. Close the secondary filler (BS) of the tank.
- 9b6. Close the cock (P15) of the mixer.
10. Move to the place to be treated, by keeping the mixture agitation at a 500 r.p.m. PTO turning rate along the whole way.

FILLING DIRECTLY IN THE TREATMENT AREA:

11. Disengage the drive outlet (PTO).
12.   **Stop the tractor and remove the key from the control panel.**
13. Ensure that the fan is stopped. Engage the fan to the servo amplifier as indicated at point 8.1.
-  **Tighten the protection-securing nut properly.**
14. Start the tractor.
15. Engage the Power Takeoff and set it up to a running rate of at least 500 r.p.m., **in order to carry out a further agitation.**
16. CARRY OUT THE TREATMENT.

8.3 - FILLING WITH THE SPECIFIC PIPE

 **Before utilisation, check the operation and proper sealing of the bottom-drawing valve by pouring water in the piping.**

EXECUTION:



1. Disengage the fan, see point 8.1.a.
2. For the models on which it is foreseen: check that the cocks (P11) and (P12) are open: (lever on "a").
3. Position the lever of the 3-way cock (P3) to "B".
4. Close the cocks of the 2-way distributor:
 - a. if manual (P8), the levers are to be lowered (horizontally positioned);
 - b. if electric, position to "OFF" the quick-break switches (E7).
5. For the models on which it is foreseen: close the cock (P15) of the mixer.
6. Completely close the pressure regulator (P5), by turning the handle clockwise.
7. Check that the drainage opening on the cock (P3) is closed by means of the relevant plug with safety chain.
8. Connect the filling pipe to the pump (P4).
9. Immerse the filter with the bottom-drawing valve in the water to be loaded.

 **The filter must always be below the level of the water to be loaded. The piping must never be above the pump's suction point and must never be excessively bent in the vertical direction.**

10. Position the lever of the 3-way cock (P3) to "A".
11. Completely open the pressure regulator (P5), by turning the handle anti-clockwise.

8.1.b Fan engagement to perform the treatment

EXECUTION:

- Disengage the power take off (PTO) and rest the machine on the ground.
- 

Stop the tractor, remove the key from the control panel and check that the fan is stopped.
- Undo the mobile protection cap's fixing nut and rotate it so as to access the disengaging element.
- Fully press the spring push button, push the front body forward, if necessary, turning it to the right or left, until the frontal teeth of the joint engage the corresponding teeth of the pulley; at the same time, the spring push button must return to the outward position. This way, the body is again integrated with the pulley, thus transmitting the movement to the fan.
- Reposition the mobile protection cover and suitably tighten the securing nut.
- Start the tractor.

8.2 - FILLING THROUGH POURING FROM THE TOP



For this type of filling, use the supplementary filler (BS) located in the upper side of the tank, towards the rear of the sprayer.

THE INLET OF THE FILLER PIPING MUST NEVER COME INTO CONTACT WITH THE ANTI-PARASITIC MIXTURE: IT MUST ALWAYS BE KEPT AT A SAFE HEIGHT ABOVE THE TANK FILLER AND MUST BE EQUIPPED WITH A NON-RETURN VALVE.



THE PUMP MUST NEVER RUN DRY

EXECUTION:

- Disengage the fan: see point 8.1.a.
 - Position the lever of the 3-way cock (P3) to "A".
 - Completely open the pressure regulator (P5), by turning the handle anti-clockwise.
 - For the models on which it is foreseen: position the lever of the cocks (P11) and (P12) of the additional agitation pump (P10) on "a".
 - Close the cocks of the 2-way distributor:
 - if manual (P8), the levers are to be lowered (horizontally positioned);
 - if electric, position to "OFF" the quick-break switches (E7).
 - For the models on which it is foreseen: close the cock (P15) of the mixer.
 - Pour some water into the tank, up to 1/3 of its capacity.
 - Start the tractor and engage the PTO; **then bring it up to a 500 r.p.m. rate.**
- 9a. **WHEN NOT USING THE MIXER (WITH MEDICINE MIXTURES OR LIQUID PRODUCTS)**
- Pour the medicine mixture foreseen for every loading (and the possible washing water for the product packs and for the instruments used for preparing the mixture) into the main filler (BP).
 - Close the main filler (BP) of the tank.
 - Complete the filling with water through the secondary filler (BS).
 - Close the cover of the secondary filler (BS).

9b. WITH POWDER PRODUCTS, WHEN USING THE MIXER (IF FORESEEN)

P1. TANK

Tanks utilised:

polyethylene tanks of 600, 800 and 1000 litre capacity

Each tank is made up of:

- tank main filler (BP) with overturning cover having a diameter of 355 mm, with breather pipe. Plastic cup-like filter: 302 mm external diameter, height 254 mm (powder mixing device, **on request**);
- supplementary tank filler with 250 mm diameter screw-type lid, for filling with clear water and plastic cup-like filter: external diameter 204 mm, height 240 mm;
- transparent level indicator external pipe with graduated scale, (One on the left-hand side of the tank L1 and one on the front side L2);
- hydraulic agitation connected to the return piping (T3);
- pneumatic agitation;
- piston cock, positioned over the tank and connected through a pipe to the air inlet, which is placed on the fan casing, for opening/closing the pneumatic agitation;
- additional 15 litres hands-washing tank, realized in polyethylene, with external utility cock.

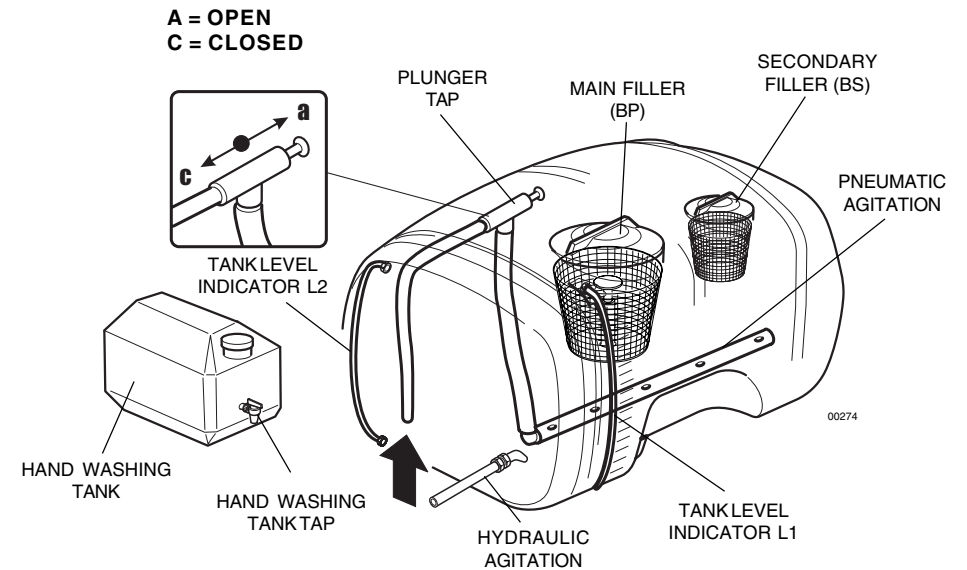

T1. SUCTION PIPING

It connects the main tank with the centrifugal pump (P4). In the connecting pipe between the tank and the pump, the 3-way cock (P3) is inserted.

P3. 3-WAY LEVER TAP A WITH DISCHARGE FITTING

Positioned on the pipe (T1), between the tank (P1) and the pump (P4), it is equipped with a closing plug of the discharge fitting, with the relevant safety chain.

The 3-way lever (P3) can be positioned as here following specified:

a – Treatment

The liquid gets out from the tank (P1) and is sucked by the pump (P4); this is the NORMAL operating position, which is used in order to carry out the treatment and/or to keep the mixing on. The discharge fitting is closed.

b – Filling

After having closed the discharge fitting by means of the relevant plug equipped with the safety chain, this position is used in order to fill the tank through the especially foreseen pipe, to be applied to the fitting on the pump (P4). Both the discharge fitting, by means of the safety chain, and the pump suction from the tank are closed.

c – Drainage

In this position, it is possible to empty: the tank (P1), the pump (P4) and all the pipes of the hydraulic circuit.

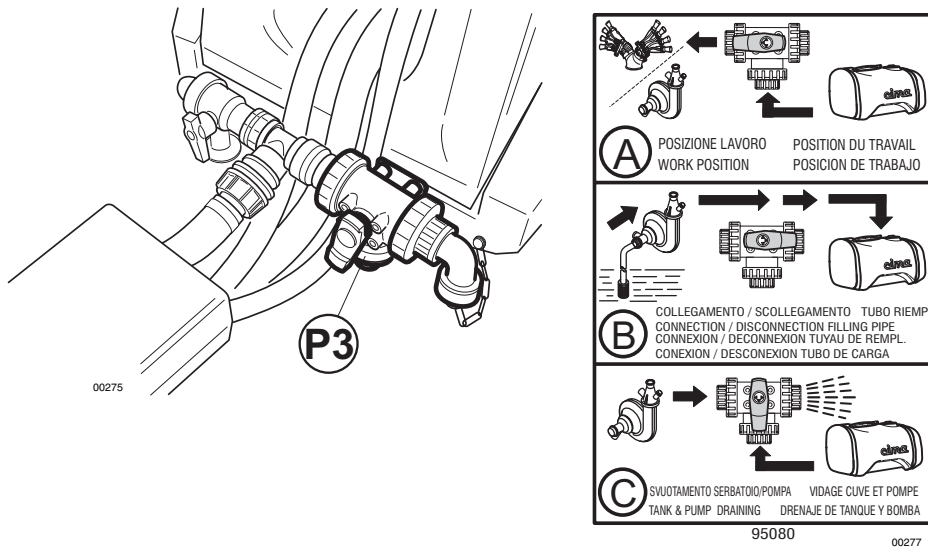

P4. CENTRIFUGAL PUMP

Fastened on the unit left front section, it is connected with the 3-way cock (P3) and with the pressure regulator (P5).



THE PUMP HAS NEVER TO RUN DRY

T2. PUMP (P4) DELIVERY PIPE

It connects the pump (P4) with the pressure regulator (P5).

FILLING MUST BE CARRIED OUT WITH THE MACHINE ON A FLAT SURFACE. ON THE SITE, BEFORE THE OPERATION, THE DOSES OR THE MIXTURES TO BE POURED INTO THE TANK MUST BE PREDISPOSED.





IT IS NECESSARY TO ALWAYS MAKE USE OF PERSONAL PROTECTION.

8.1 - FOREWORD - USE OF THE FAN DISENGAGEMENT (For versions in which this is envisaged)

8.1.a Disengagement of the fan

EXECUTION:

1.   Stop the tractor, remove the key from the control panel and check that the fan has stopped.
2. Undo the mobile protection cap's fixing nut and rotate it so as to access the disengaging element.

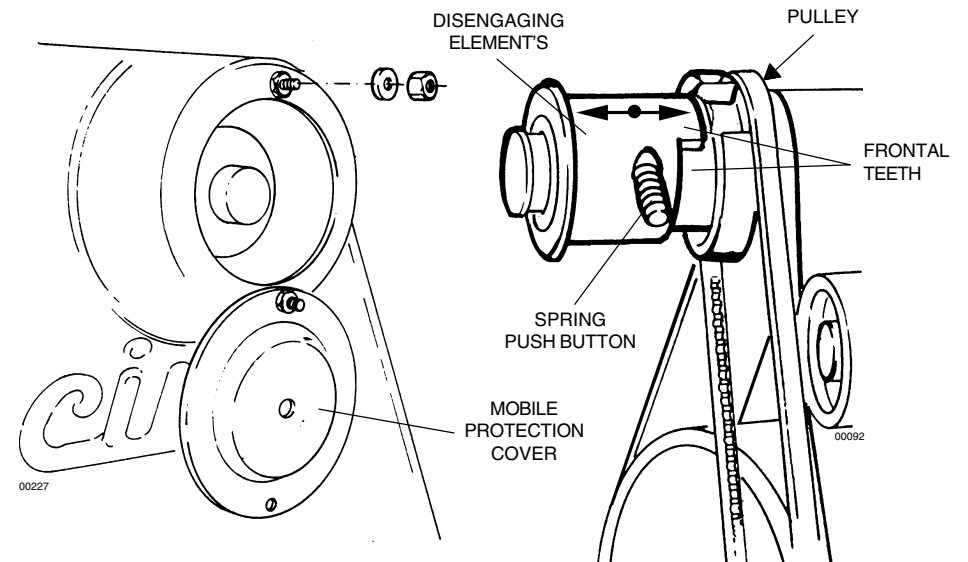

3. Fully press the spring push button and pull the front element until it springs out. The body disengaged from the retaining joint must turn freely: the pump will operate and the fan will thus be excluded.
4. Reposition the mobile protection cover and fasten the locking nut properly.
5. Start the tractor and carry out the filling operation.

7.1 - FILLER PIPE

The pipe is provided with a coupling elbow fitting and with a bottom-drawing valve. This is used for the filling of the tank. It must be screwed into place on pump "P4" instead of the chain-held stopper.

 The assembly has ALWAYS to be carried out with the P3 cock positioned on "B".

 Before making use of it, it is necessary to check the operation and the proper sealing of the bottom-drawing valve, by pouring water into the pipe.

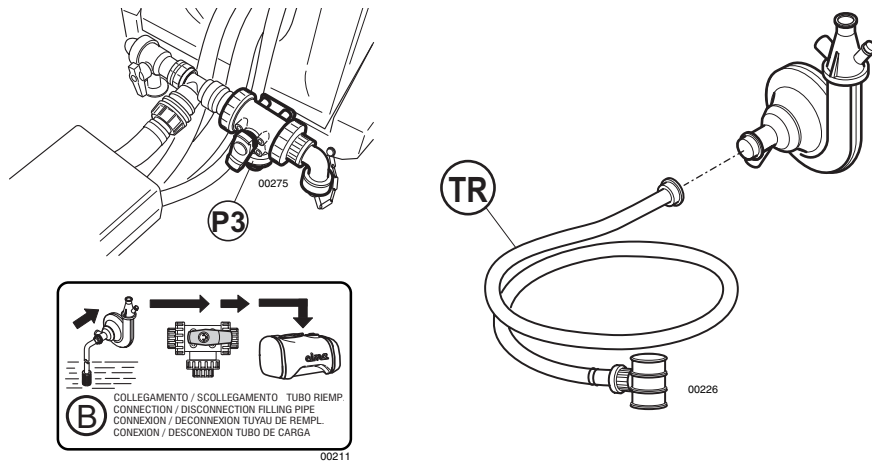

7.2 - ELECTRICAL TURN DEVICE

It is an accessory utilised to modify the direction of the pulverising. It can be used only with some types of distribution devices.

 All indications and instructions are provided in the use and maintenance booklet of the distribution devices with which it can be used.

P5. PRESSURE REGULATOR

It is connected to the delivery filter (P6) and, through pipe (T3), to the tank (P1). It regulates the operating pressure, by controlling the return flow to the tank.

- **By closing it: it REDUCES the return flow** to the tank and therefore, the agitation of the mixture, and increases the operating pressure and the capacity flow to the head (rotate the handle clockwise).
- **By opening it: it INCREASES the return flow** to the tank and therefore, the agitation of the mixture, while reducing the operating pressure and capacity flow to the head (rotate the handle anti-clockwise).

 When treatments are carried out with heavy powder products, which have a tendency to form a deposit on the tank bottom, it is necessary to operate with a working pressure of 1 – 1,5 atm, in order to get a better hydraulic agitation of the mixture.

T3. RETURN TO TANK PIPING

It connects filter (P6) to tank (P1), at the point on which the hydraulic agitation is mounted.

P6. FILTER

It is connected, through pipe (T4) to the distributor (P8/E7).

The filter has a filtering capacity of 250 l/min., with a 50 mesh cartridge.

The dirty cartridge causes the operating pressure to drop.

This inconvenient is signalled by the pressure gauge.

Mounted on the feeding pipe, it only filters the delivery flow to the heads, by sensibly reducing the possibility for the cartridge to get obstructed.

To the distributors:
either manual (E8)
or electric (E7)

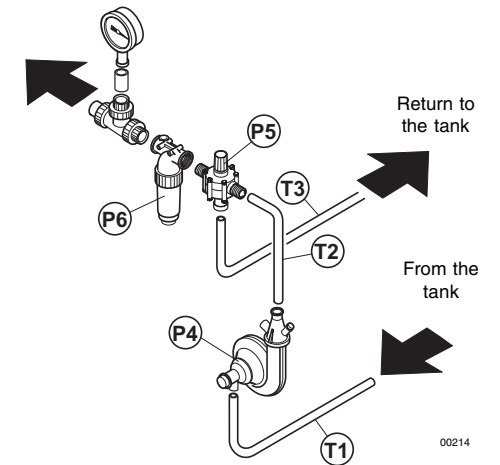

It is positioned on the pipe (T8) between the filter and the mixer, on the main filler, in correspondence with the point where the pipe enters into the tank.

- OPEN (position "a") the cock, in order to carry out the drainage or the mixing of the powder products;
- CLOSE (position "c") the cock when those operations aren't required.

T8. PIPING FOR THE MIXING (For versions in which this is envisaged)

It connects the filter cock (P6) with the cup-like filter of the tank main filler (BP).

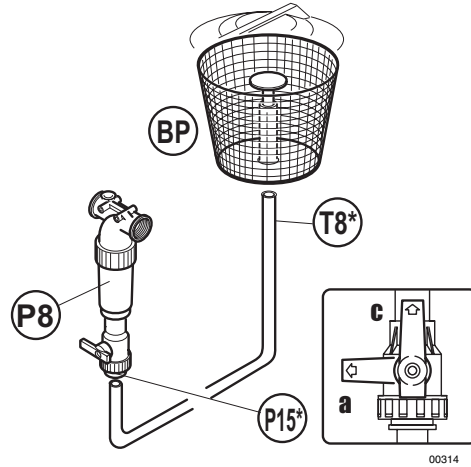

P16. MIXER (For versions in which this is envisaged)

It carries out the mixing of the powder insecticides, during the tank filling. Mounted on the cup-like filter of the main filler (BP), it is connected with the filter (P6) through the pipe (T8).

P7. GAUGE

Glycerine-dipped, with dial from 0 to 6 Kg/cm² (atmosphere) – adjustments scale of **1/10 of atmosphere**, 100 mm diameter; it is connected to filter (P6).



Set the working pressure keeping the P8 (or E7) distributors opened.

T4. PIPING FOR THE FEEDING

It connects the filter (P6) to the manual distributor (P8) or electric distributor (E7).

P8. MANUAL DISTRIBUTOR WITH 2 LEVER-OPERATED TAPS

It connects the feeding pipe (T4) to the distribution piping (T5). It remote-controls the closing and opening of the pulverising. The mount bracket, supplied with the machine, must be secured to the tractor within the driver's reach.

When the machine is not hitched to the tractor, it must be placed on the forward part of the sprayer's frame.

Each tap permits the spraying from a single side of the head: to the right and to the left respectively. They are **open** when the levers are set in the **vertical** position. They are **closed** when the levers are **horizontal**.

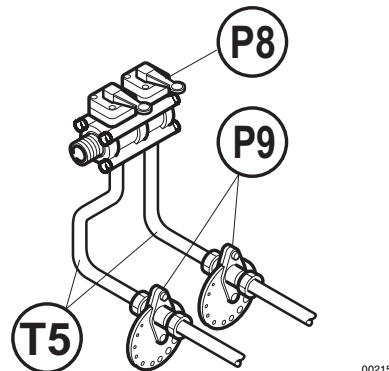

Every distribution device is supplied with its own **USE AND MAINTENANCE** booklet that is, or will have to be, attached to this publication and will constitute one of its integral parts.

6.1 - TYPES AND IDENTIFICATION CODES

Distribution device - Head	LINK 45	LINK 50
4+4 diffuser head with 8 taps	T4+4.45.01	T4+4.50.01
5+5 diffuser head with 10 taps	T5+5.45.01	T5+5.50.01
4+4 diffuser head with 8 taps Strasbourg type	T.ST4.45T.01	T.ST4.50T.01
7 diffuser canopy head	T.TND.45.01	T.TND.50.01
2-fishtail sprayhead with 3 sectors large	T.2V.3L.45T.02	T.2V.3L.50T.02
2-fishtail sprayhead with 4 sectors	-	T.2V.4.50T.01
Tobacco cannon jet with extension of 800 mm	T.GC.P06.45.02	-
Tobacco cannon jet (multiple diffuser) with extension of 800 mm	-	T.GC.P06.50.02
Olive multiple head with 4 diffuser	T.OL.000.45.01	T.OL.000.50.01
Olive multiple head with 4 diffuser and extension of 800 mm	T.OL.P06.45.01	T.OL.P06.50.01
2 lower hands and 2 upper cannons head	TC.2M2C.45S.01	TC.2M2C.50S.01
2 lower hands and 4 upper cannons head	TC.2M4C.45S.01	TC.2M4C.50S.01
2 lower hands and 2 upper cannons head, France type	TCF.2M2C.45S.02	TCF.2M2C.50S.02
2 lower hands and 4 upper cannons head, France type	TCF.2M4C.45S.02	TCF.2M4C.50S.02
2 hands and 4 cannons head with hydraulic control	TCI2M4C.45S.11	TCI2M4C.50S.11
4 hands head (2 lower and 2 upper)	TC.2M2M.45S.01	TC.2M2M.50S.01
Coffee head	TC.CA.45P.01	TC.CA.50P.01

3 – Connect the distribution piping T7 to the hydraulic circuit of the distribution device (head) mounted on the machine (follow the instructions of the specific “use and maintenance” book-let which is supplied with it).



Position the distribution piping T7 and feed piping T6 so as to avoid the risk of suffering damage or breakage during spraying. If necessary, utilise suitable securing clamps.

IN CASE OF BREAKAGE:

- 1 – Stop the tractor and remove the key from the control panel.
- 2 – Close the 2 taps of distributor “P8”.

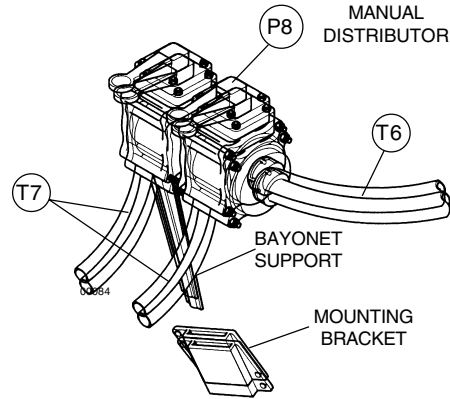

5.3.2 - Electrical control panel - E8

- 1 – Mount the securing clamp on the tractor within the driver’s reach.
- 2 – Insert the bayonet support of the control panel in the securing clamp.
- 3 – Connect the main cable “W1” inserting the plug into the mains socket of the tractor.



The mains cable “W1” is provided complete with main socket to be mounted on tractors that might not be equipped with it, or to replace the existing one should it be incompatible with the plug.

4. Connect the distribution piping T7 to the hydraulic circuit of the distribution device (head) mounted on the machine (follow the instructions of the specific “use and maintenance” book-let which is supplied with it).



Position the electrical cables W1 and W2 in such a way as to avoid risking their being wrenched off during treatments. If necessary, use some securing clamps. A sudden interruption of power will lock the 2 solenoid valves of the electrical distributor “E7”. Should this fault take place when they are in the open position, it is necessary to:
- Stop the tractor and remove the key from the control panel.

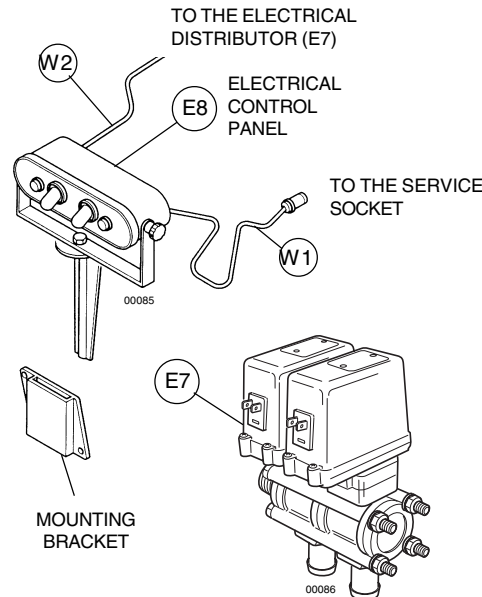

E7. ELECTRICAL DISTRIBUTOR WITH TWO SOLENOID VALVES

It is connected with the feeding pipe (T4), the distribution pipes (T5) and the electrical unit (E8), which is fastened on the tractor. The solenoid valves open and close themselves, according with the action carried out on the electrical control unit switches.

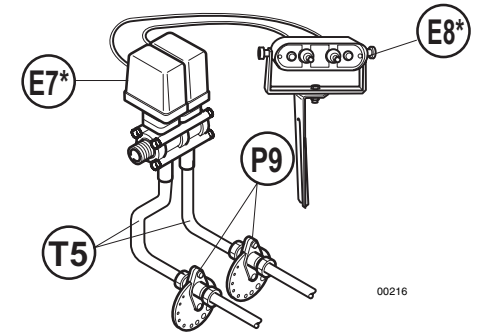

E8. CONTROL UNIT

It is electrically connected to the distributor with 2 motorised solenoid valves (E7) and to the main socket of the tractor. The control unit is supplied with a complete electrical plug, should the one present on the tractor be unsuitable for connection.

The 2 lever switches, controlling the solenoid valves (E7), have to be set to “ON” for opening and to “OFF” for closing. The control unit is equipped with a bayonet support to be inserted in the bracket provided. This must be mounted on the tractor, within the driver’s reach. When the machine isn’t hitched to the tractor, it must be placed in the position foreseen on the forward part of the machine frame.

T5. DISTRIBUTION PIPING

It connects the distributor (P8/E7) to the calibration disc (P9) assembled on the distribution devices.

P9. CALIBRATION DISC

It selects the flow rates necessary to the treatment and is mounted on the distribution devices. It is made up of 2 flanges, held in position by two butterfly nuts, locking a disc with calibrated holes numbered from 1 to 15. A groove on the edge of the disc allows the exact positioning of the hole to be utilised. Its number must appear in the flange’s semi-circular seat. The rotation of the disc is obtained by loosening the butterfly nuts by a few turns. After the operation is done, screw back carefully.



Any faulty sealing condition of the hydraulic circuit causes an intermittent issuing of the sprayed material. It is necessary to carefully check the efficiency of the sealers and clamps, the tightening of the ring nuts and fittings and the good working condition of the piping.

P10. ADDITIONAL AGITATION PUMP (For the models on which it is foreseen)

Fastened on the machine right front side, it is connected to the suction tank, through cock (P11), and to the delivery tank, through cock (P12).



THE PUMP HAS NEVER TO OPERATE DRY.

T6. ADDITIONAL PUMP SUCTION PIPE

(For the models on which it is foreseen)

It connects the main tank (P1) with the centrifugal pump (P10). On the suction pipe, the cock (P11) is inserted.

T7. ADDITIONAL PUMP DELIVERY PIPES

(For the models on which it is foreseen)

It connects the centrifugal pump (P10) with the main tank (P1). On the delivery pipe, the cock (P12) is inserted.

P11. ADDITIONAL PUMP SUCTION COCK

(For the models on which it is foreseen)

Positioned on the pipe (T6), between the main tank (P1) and the centrifugal pump (P10), it can be set to the following positions:

a – Open

The liquid is sucked from the main tank (P1) and, through the centrifugal pump (P10), it is sent back to the tank, by causing the mixture hydraulic agitation.

b – Closed

P12. ADDITIONAL PUMP DELIVERY COCK

(For the models on which it is foreseen)

Positioned on the pipe (T6), between the centrifugal pump (P10) and the main tank (P1), it can be set to the following positions:

a – Open

The liquid is sent from the centrifugal pump (P10) to the main tank (P1).

b – Closed

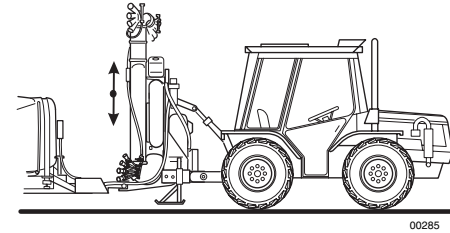
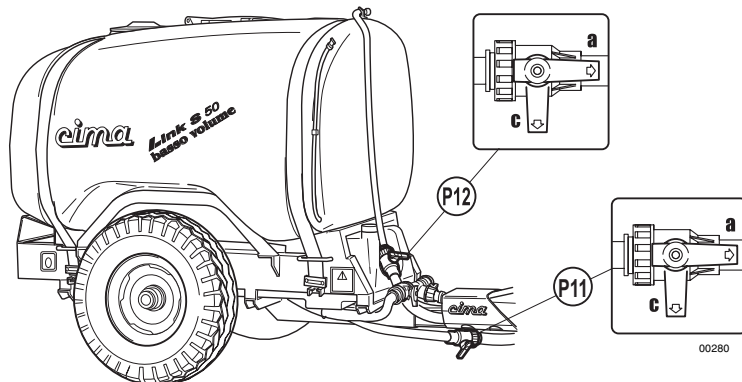

00285

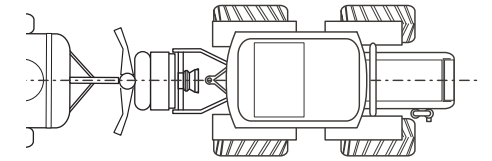

00286

5.2 - MOUNTING OF THE TRANSMISSION SHAFT



USE TRANSMISSION SHAFTS WITH CE CERTIFICATION. OBSERVE THE REGULATIONS CONTAINED IN THE USE AND MAINTENANCE BOOK-LET PROVIDED BY THE SHAFT MANUFACTURER.



The transmission shaft must work with the 2 COAXIAL drive outlets (PTO) or, should this not be possible, with the PARALLEL axles. In this case the angle of the joint MUST NOT EXCEED 15°.

Definition of the length

Set the 2 drive outlets (PTO) perfectly on the same axis and measure the distance "D" between their grooves.

Length "L" of the transmission shaft (refer to the picture) to be deployed, measured between the 2 stopping pawls and with joint closed, must be 25 mm lesser than distance "D".



The mounting, disassembling or possible other interventions on the transmission shaft must be carried out with the engine switched off and with the starter key removed from the tractor's control panel.

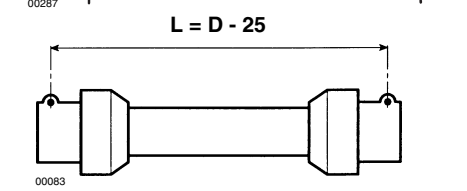
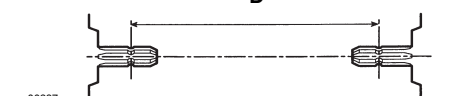
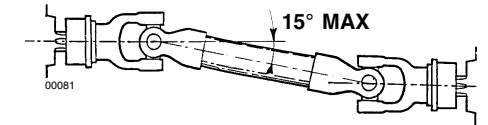

5.3 - INSTALLATION OF REMOTE CONTROLS

5.3.1 - Manual 2-tap distributor - P8

- 1 – Mount the securing bracket on the tractor within the driver's reach.
- 2 – Insert the distributor's bayonet support in the securing bracket..

5.1 - HITCHING TO THE TRACTOR



Check that the tractor's "permissible carried weight" and the "rear overhang allowed" are compatible with the weight and dimensions of the fully loaded sprayer and complete with equipment mounted for the treatment (see Paragraphs "3.1" - "4.4.1" and the attached documentation).







The tractor's power take-off (PTO), under all utilisation conditions, must provide a power exceeding that absorbed by the sprayer.

The hitching between sprayer and tractor must be carried out on a flat surface, keeping away people not involved in the operation, as well as children and animals.

Pairing suggested for tractors of at least	LINK 45	LINK 50
CV SAE	45	65
kW	33	48

LINK005GB

EXECUTION:

- Loosen the chains of the lifter arms.
- Start the tractor and take the lifter's arms to the level of the machine's pins.
- 

Stop the tractor and remove the key from the control panel.
- Insert the toggle joints on the machine's pegs, locking them with the clip pins.
- Hook the sprayer 3rd point rod, securing it with the peg and clip pin, screwing it finger-tight to set it into tension.
- Start the tractor and hoist the sprayer until the 2 PTO are the same height.
- 

Stop the tractor, remove the key from the control panel and make sure that no one approaches the hydraulic controls of the lifter. NEVER OPERATE OR STAND BENEATH THE MACHINE OR IN THE AREA THAT COULD BE INVOLVED IN ITS SUDDEN LOWERING.
- By acting on the 3rd-point rod, vertically align the sprayer. **N.B.:** block the 3rd-point rod with the specific lock ring.
- Block the coupling by tightening the chains of the hoister arms.



When the operation is completed the 2 drive outlets (PTO) must be positioned on the same axis, both in vertical and horizontal direction.

P13. UNIT WASHING TANK

(For the models on which it is foreseen)

The unit washing tank (P13), realized in polyethylene, having a capacity of 76 litres for the 600 and 800 litres' models, and in stainless steel plate, with a capacity of 100 litres for the 1000 litres' models, is positioned under the main tank (P1). The tank is equipped with a filler and is connected, through the pipe (T9) and the cock (P14) to the sprayer hydraulic circuit.

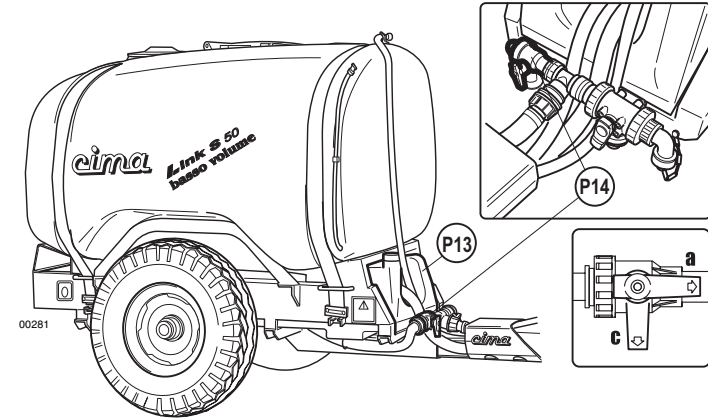

P14. UNIT WASHING COCK

(For the models on which it is foreseen)

Positioned on the pipe (T8), between the unit washing tank (P13) and the 3-way cock (P3), it can be set to the following positions:

a – Open

The liquid is sucked from the unit washing tank (P13) and, through the centrifugal pump (P4), it is sent for being delivered, through the pressure regulator (P5) and the filter (P6), so allowing to get the unit washed.

NOTE: In order to carry out the unit washing, the 3-way cock (P3) has to be set to position "B".

b – Closed

T9. UNIT WASHING PIPES

(For the models on which it is foreseen)

It connects the unit washing tank (P13) to the unit washing cock (P14).

4.4 - TECHNICAL DATA

4.4.1- Sprayer dimensions and weights

		Tank capacities (litres)		
		600	800	1000
LINK 45	Total width(mm)	1060	1090	1380
	Total height (mm)	1250	1370	1370
	Lenght (mm)	3050	3310	3350
	Weight, empty (kg)	340	360	420
	Weigth of washing system tank full	88	88	126
	Weight, full load (kg)	956	1166	1436
	Weight, full load, on hydraulic hoist (kg)	280	290	300
LINK 50	Total width(mm)	1060	1090	1380
	Total height (mm)	1250	1370	1370
	Lenght (mm)	3100	3370	3430
	Weight, empty (kg)	376	490	450
	Weigth of washing system tank full	88	88	126
	Weight, full load (kg)	986	1206	1466
	Weight, full load, on hydraulic hoist (kg)	310	320	330

LINK001GB

(without distribution devices)

4.4.2 - Wheels: dimensions and operating pressures

MODEL	MEASURE	WHEEL-HUB	PRESSURE
LINK 45 600 - LINK 50 800	175/70.13	5 F	atm. 2,5
LINK 45 800 - LINK50 800	7,00-12	5 F	atm. 2,5
LINK 45 1000 - LINK50 1000	10/80.12	5 F	atm. 3,3

LINK002GB

4.4.3 - Technical specifications for fans and pump Centrifugal Fan

	LINK 45	LINK50
Fan Diameter (mm)	450	500
Fan speed (giri/min.)	4500	4000
Air flow rate (m³/h)	5400	7550
Air speed (m/s)	188	175
Power absorbed (kW)	17	24

LINK003GB



The performance specified is obtained with the drive outlet (PTO) at 540 RPM. For a good result of the treatments this condition **MUST ALWAYS BE OBSERVED** during the machine's operation. Utilisation is permitted with speed rates ranging between 500 and 620 RPM

	LINK 45	LINK 50
Steel fan	si	si
P.E. Casing	si	si
Internal diameter casing outfeed (mm)	175	175
PTO shaft 1"3/8 SAE (DIN 9611/A)	si	si
Main pulley diameter (mm)	450	480
Fan control belt	650J32	690J50
Fan pulley diameter (mm)	54	64,5
Pump control pulley diameter (mm)	78	88
Pump control belt	3V 500	3V 500
Pump pulley diameter (mm)	82,5	82,5

LINK004GB

Centrifugal pump CD32

Model C.I.M.A. CD32 – Pressed in nylon – Turning open – Stainless steel shaft - Silicon carbide, stainless steel and viton mechanical seal, – Emptying cork – Oiling device with spring cover - Suction sleeve with supplementary service filler, provided with chain-retained cork.

Activated with trapezoid belt driven by the pulley mounted on the fan shaft.

- Speed 4250RPM
- Flow rate 140 litres/min.
- Maximum pressure 4.5 Kg/cm 2
- Power absorbed kW 2.5