

Sprayheads for sprayers

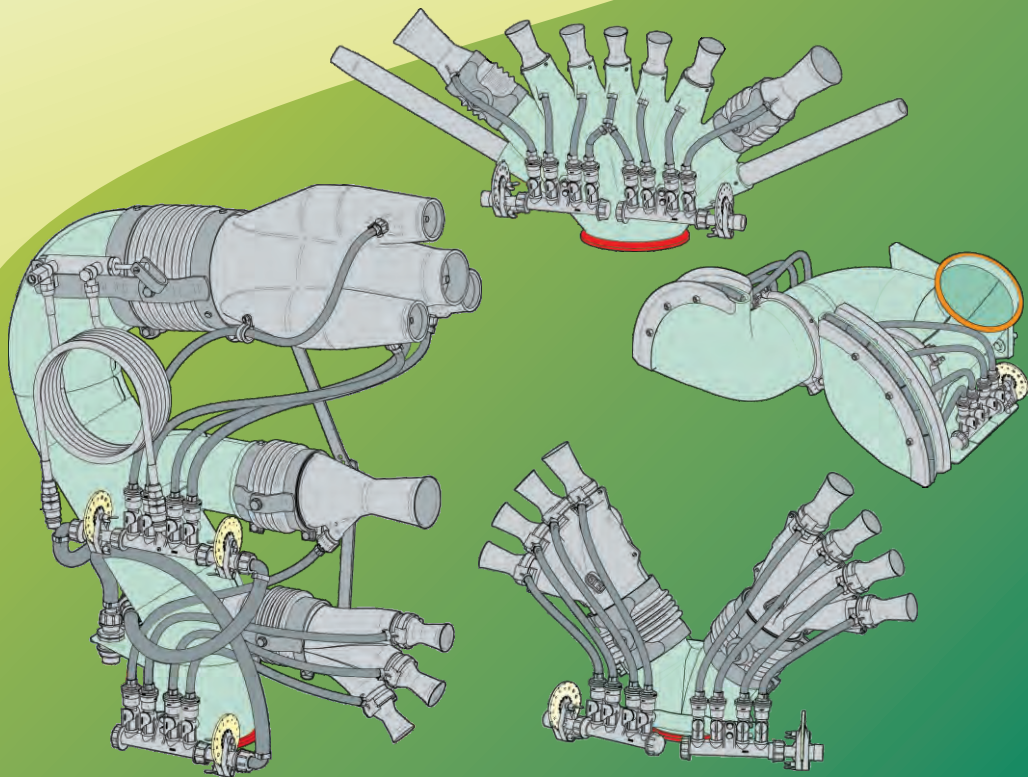

OPERATION AND MAINTENANCE INSTRUCTIONS

cima[®]

Atomizzatori e Impolveratori

Dear Customer, thank you very much!

*We want to congratulate with you, for having chosen a distribution device for **cima**[®] sprayer.*

Your choice shows the wisdom of the well-informed Purchaser, aware of the fact, that the required features of quality, technique and reliability must be satisfied at the right price!

Our continuous engagement in R&D and in testing our machines allows us to realize products able to offer the best performances, a high reliability and a great easiness of use at the same time !

Our first goal, is to get our Customers happy for having met us!

The “Spare parts catalogue” of this sprayer/sprayhead is available in the “restricted area” on website www.cima.it.

To identify the code of the sprayhead, please see the section 2.3 - Identification

In order to accede, use:

User name: SPRAYER

Password: 844719KE

Exclusively use UPPERCASE LETTER, and follow the instructions displayed on the screen

Sprayheads For Sprayers

OPERATION AND MAINTENANCE INSTRUCTIONS

(Publication n° LUM-DDA-04)

©CIMA S.P.A. - 2003-2012 PRIVATE PROPERTY

Any reproduction, even if partial, is forbidden if not preventively authorized in writing by the Cima S.p.A. company.



CIMA S.p.A. - 27040 Montù Beccaria - Loc. Molino Quaroni - (PV) - ITALIA

Tel. +39.0385.246636 r.a. - Fax +39.0385.246637

<http://www.cima.it>

LISTING OF VALID PAGES

This publication consists of 58 pages, subdivided as follows:

N° OF PAGE	REVISION	BASE
from I to V	04	February 2012
from 1 to 53	04	February 2012

REGISTRAZIONI AGGIUNTE E VARIANTI

REVISION	DESCRIPTION
00	First Edition, July 2003
01	Second Edition, June 2006
02	Third Edition, February 2006
03	Fourth Edition, February 2011
04	Fifth Edition, February 2012
05	
06	
07	
08	

GENERAL INDEX

1	FOREWORD	1
1.1	PUBLICATION IDENTIFICATION	1
1.2	ATTACHED PUBLICATIONS	1
1.3	PURPOSE OF PUBLICATION	1
1.4	REFERENCE TO REGULATIONS	1
1.5	USE OF THE MANUAL	1
2	GENERAL INFORMATION	2
2.1	IDENTIFICATION	2
2.2	CLASSIFICATION	3
2.2.1	Hands	4
2.2.2	Cannons jet	4
2.2.3	Fishtails	4
2.3	IDENTIFICATION	14
2.4	CUSTOMER SERVICE	23
2.5	SAFETY WARNINGS	23
3	DISTRIBUTION DEVICES' COMPONENTS	24
3.1	HANDS	24
3.2	CANNONS JET	27
3.3	FISHTAILS	28
3.4	VARIOUS COMPONENTS	28
4	MOUNTING FEATURES	33
4.1	MOUNTING	33
4.1.1	Electrical c connection	37
4.1.2	Hydraulic input connection for the sprayhead movement	37
4.2	HEIGHT ADJUSTMENT	38
5	PROCEDURE FOR SPRAYHEAD USE	42
5.1	HEADS	42
5.2	CANNONS JET	44
5.3	FISHTAIL	47
5.4	MANUAL SWIVELLING DEVICE	48



5.5	ELECTRICALSWIVELLINGDEVICE	48
6	DELIVERIES' TABLE	49
7	MAINTENANCE OPERATIONS	50
8	TROUBLESHOOTING	51
9	WARRANTY	53
9.1	WARRANTY	53
9.2	REPPONDING DEFECTS IN GOODS	53
9.3	TO PASS SAFETY INFORMATION	53

1.1 - PUBLICATION IDENTIFICATION

The "OPERATION AND MAINTENANCE INSTRUCTIONS" manual is an integrative part of the sprayers. It is identified by a Publication No. located on the frontispiece, and through which the document can be identified, traced and/or subsequently referred to.

The information elements contained herein are updated as at the date of publication. C.I.M.A. S.p.A. reserves the right to modify its machines without notice, with the purpose of applying technical enhancements, and it declines all responsibility for possible omissions from the publication.

All rights are reserved. No parts of this book may be reproduced or utilized in any form or by any means, electronic or mechanical, including photocopying, recording, or by any information storage and retrieval system, without permission in writing by C.I.M.A. S.p.A.

1.2 - ATTACHED PUBLICATIONS

— Spare parts catalogue.

1.3 - PURPOSE OF PUBLICATION

All indications contained in this manual are aimed at the user of the sprayer.

The duration of the sprayhead and its operation, the operator's safety and the respect for the environment are dependent upon scrupulous observance of the stated norms.

Before making use of the sprayer, the user must read, understand and abide by all regulations listed in this manual.

1.4 - REFERENCE TO SPECIFICATIONS

This manual was set out conforming to the regulations contained in the following documents:

- Directive 2006/42/CE: Attachment 1 point 1.7.4;
- UNI 10653: Technical Documentation;
- UNI 10893: Technical Documentation.

1.5 - USE OF THE MANUAL

Read every part of this manual, paying attention to the **WARNING** and **DANGER** indications both on the text and on the machine or on components.

All operations suggested by the manual will have to be followed with the utmost care and only after having understood the negative consequences of improper usage.

The following "**symbols**" are used within the text in order to highlight and visually identify the importance of the various types of information:



Indicates important additional information



Highlights possibly dangerous situations to people.



Non observance can result in permanent damage to the sprayer or sprayhead.

The manual, with relevant attachments and possible integrating issues, must be kept with the utmost care and must always be complete, integer and legible in every part. Should it be mislaid it is imperative to immediately request a duplicate from C.I.M.A. S.p.A. Should the decal originally applied on the sprayhead be mislaid, damaged or become incomprehensible, they should be promptly replaced.



- The manual must always be kept for the sprayer's whole operational life.
- Any modification received must be permanently inserted in this publication.
- The manual must be ceded with the sprayer should this be sold.

2**GENERAL INFORMATION****2****2.1 - IDENTIFICATION**

The Sprayheads realized for the sprayers 42, 45 and 50 have the same coupling diameter to the fan outlet mouth or to the connecting elbow. In order to differentiate the Sprayhead, according with the class of the sprayer on which it has to be used, on the same one a decal is applied, indicating the class of the fan on which the distribution device can be mounted.



The use of sprayheads belonging to a class different from the sprayer's one, negatively affects the delivery efficiency, by diminishing the treatment performance.

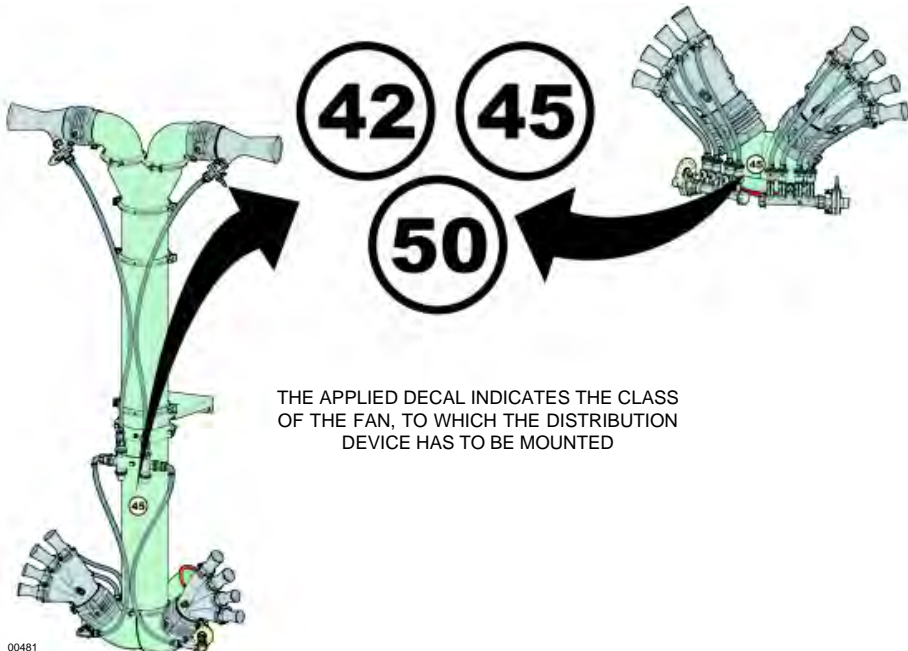

00481

2.2 - CLASSIFICATION

The distribution devices (sprayheads) are classified, according with the complexity of the device itself and on the basis of the type of outlet device used. The sprayheads are therefore divided into two categories, the simple sprayheads' and the combined sprayheads' ones. The combined sprayheads are characterized by the simultaneous use of outlet devices of different types, employed in order to obtain a covering really answering to the requirements of the culture to be treated, and, in case of particularly large cultures, by the use of suitable support frames.

Simple Sprayheads

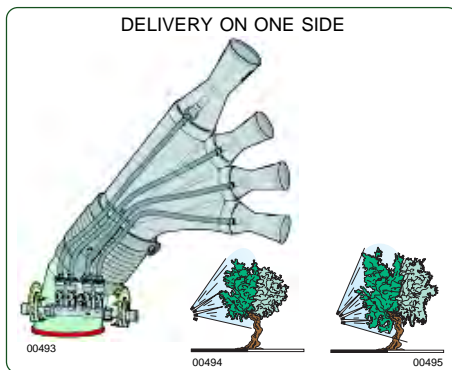
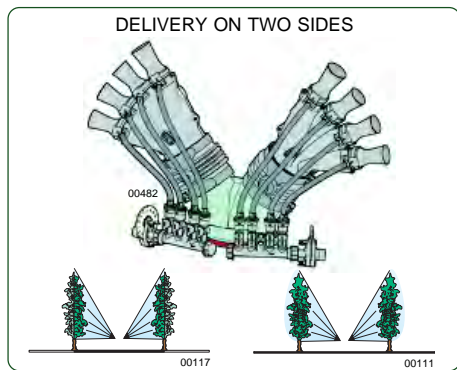

Combined Sprayheads

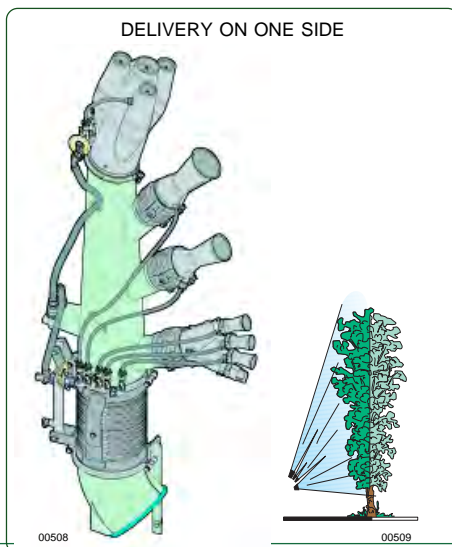
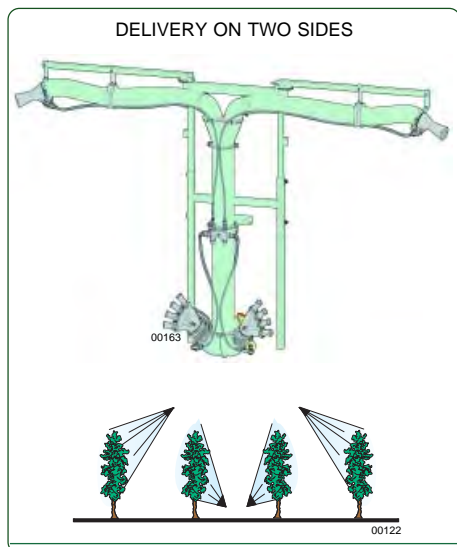

The outlets to be used can be subdivided into the following types:

- hands (with the relevant diffusers);
- cannons;
- fishtails.

2.2.1 - Hands

The “hands” consist of a central body, to which 2 up to 5 diffusers are applied.

The hands are connected to the sprayhead body through a flexible sleeve and a double joint clamp. Upon request, a hydraulic cylinder for remote-controlling the sprayhead orientation can be applied to the central body.

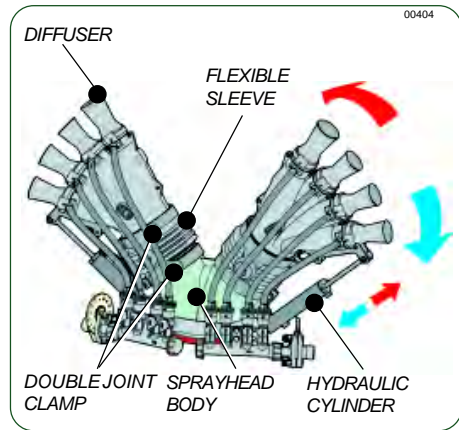

2.2.2 - Cannons jet

The “cannons jet” consist of a single body, which is directly fixed to the sprayhead body.

They are connected with the sprayhead body through a flexible sleeve and a double joint clamp which allows the proper orientation. Upon request, a hydraulic cylinder (or an electric piston) for remote-controlling the sprayhead orientation can be applied to the central body.

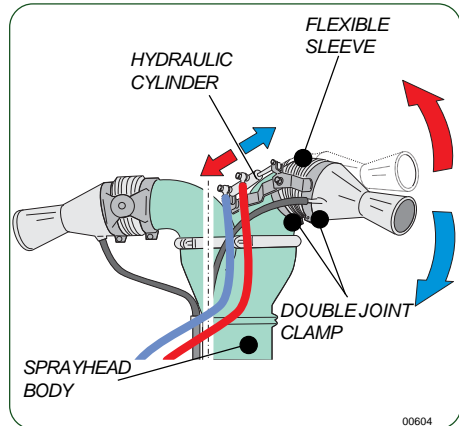

2.2.3 - Fishtails

The “fishtails” are either directly fixed to the sprayhead body or they are connected to it through a flexible sleeve and the relevant double joint clamp. They are realized according to different sizes, on the basis of the sprayhead and the machine on which they must be used.

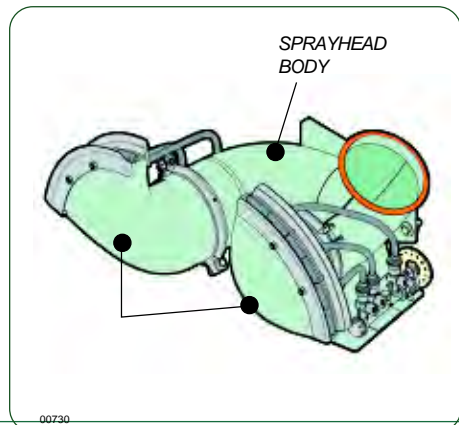

The following figures illustrate the most commonly sold distribution devices, which can be used with the **C.I.M.A. low volume sprayers**. Other models are available, or are realized upon a specific request, in order to meet special requirements; in order to get the necessary information about them, please directly contact **C.I.M.A. S.p.A. – Sales Dpt.**

4+4 SPRAYHEAD

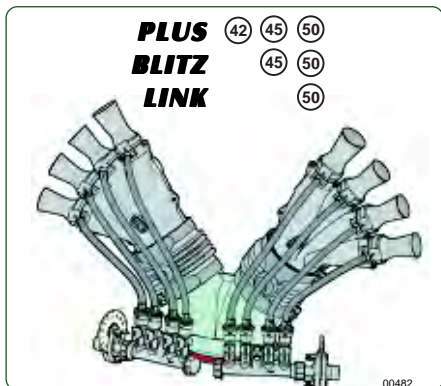

5+5 SPRAYHEAD

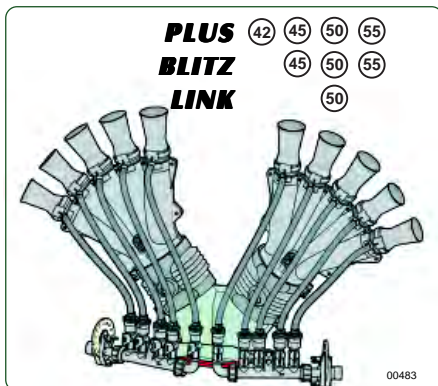

STRASBURGO SPRAYHEAD

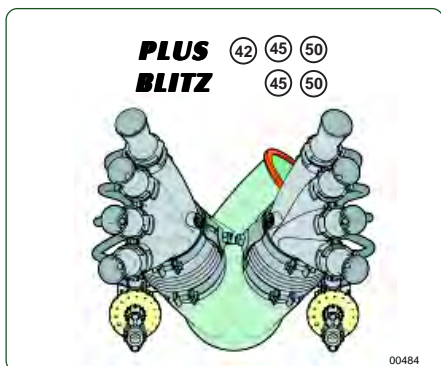

TWIN OLIVE SPRAYHEAD

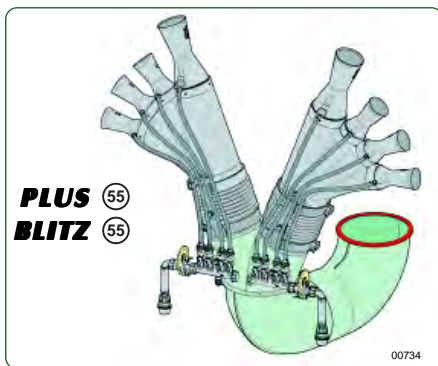

OLIVE SPRAYHEAD

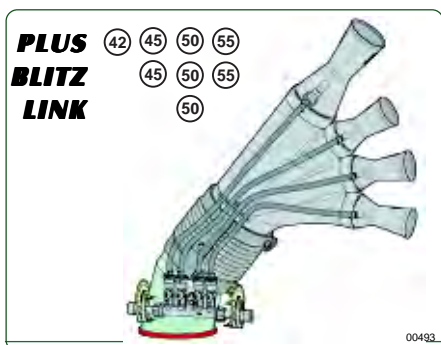

2 FISHTAILS SPRAYHEAD

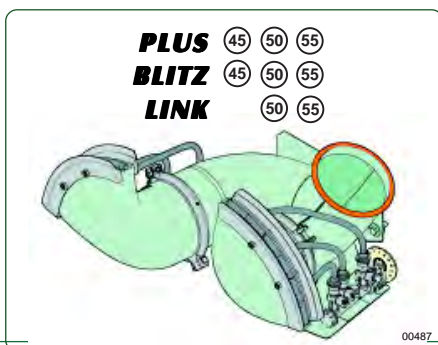

T. 4M

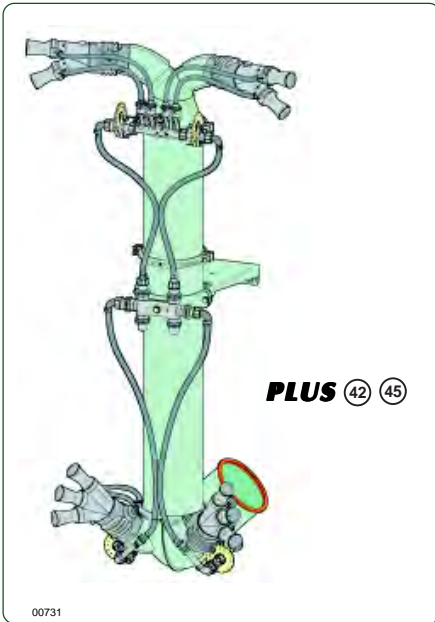

T. 6M

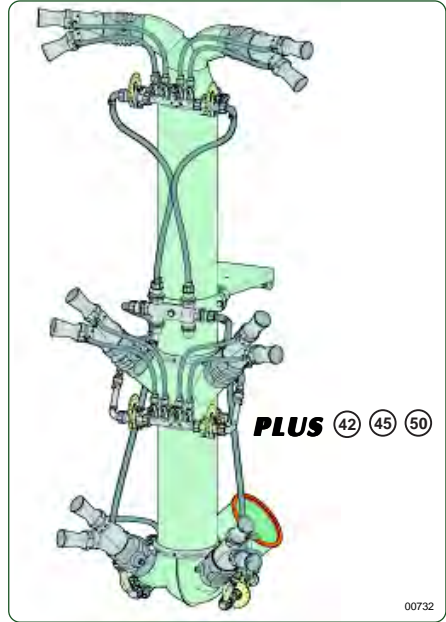

TENDONE SPRAYHEAD 7 NOZZLES



TENDONE SPRAYHEAD 9 NOZZLES



TC. 2M 2C

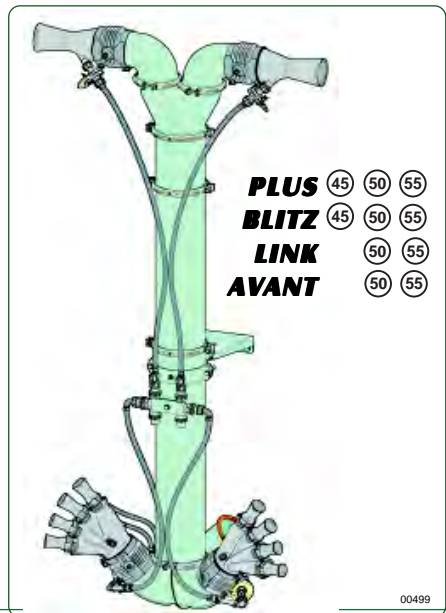

TCS. 2M 2C

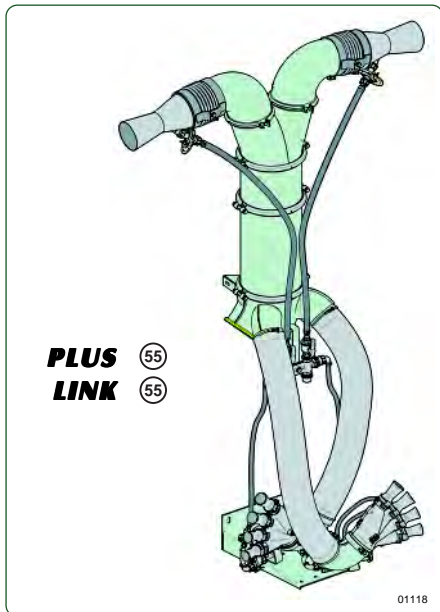

TC. 2M 2M

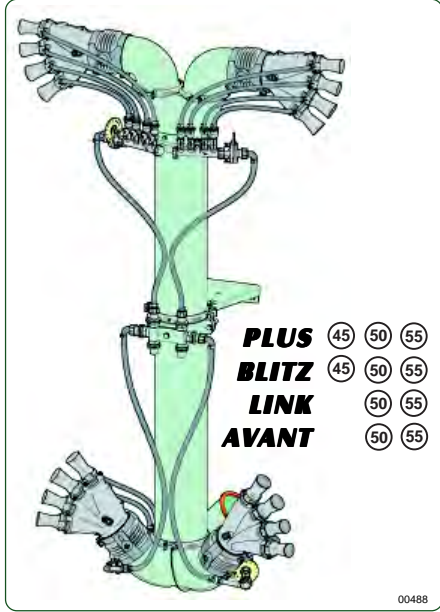

CAFFÈ SPRAYHEAD

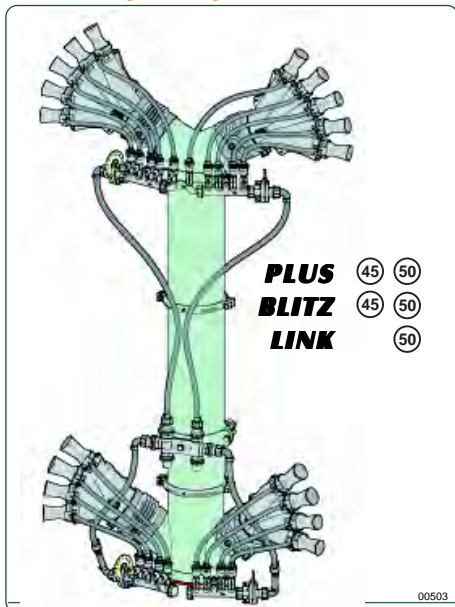

TCS. 2M 2M

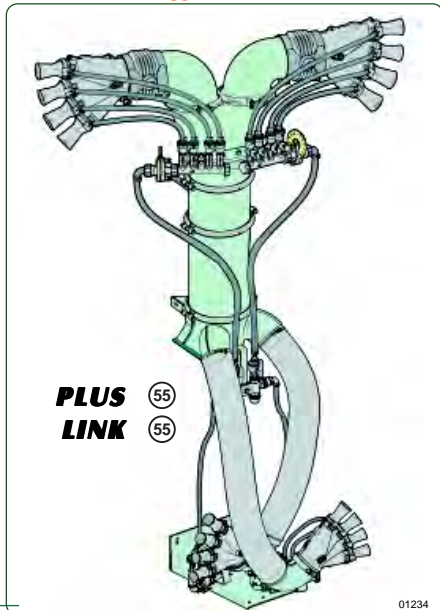

4 FISHTAILS SPRAYHEAD

6 FISHTAILS SPRAYHEAD

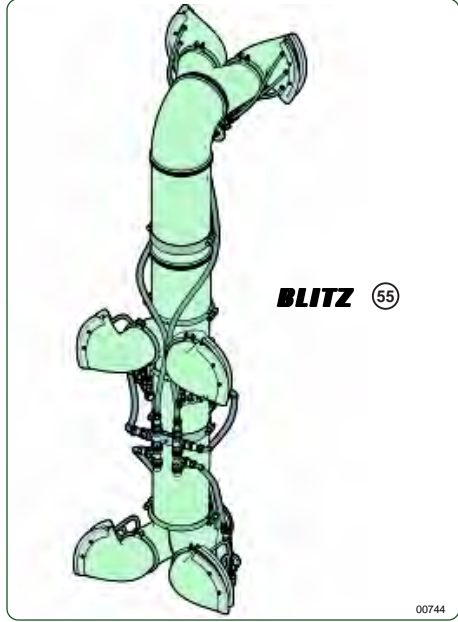
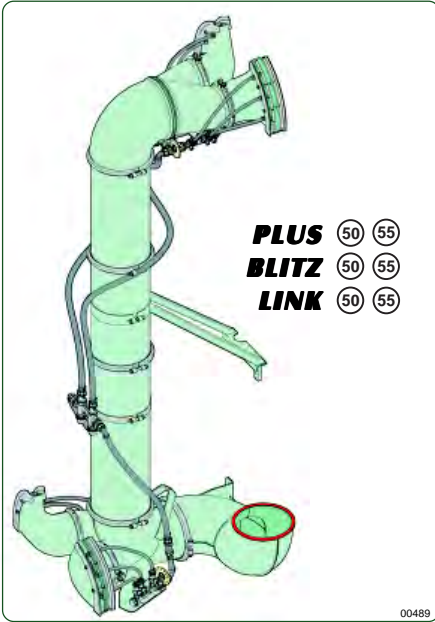

TC. 2M 4C

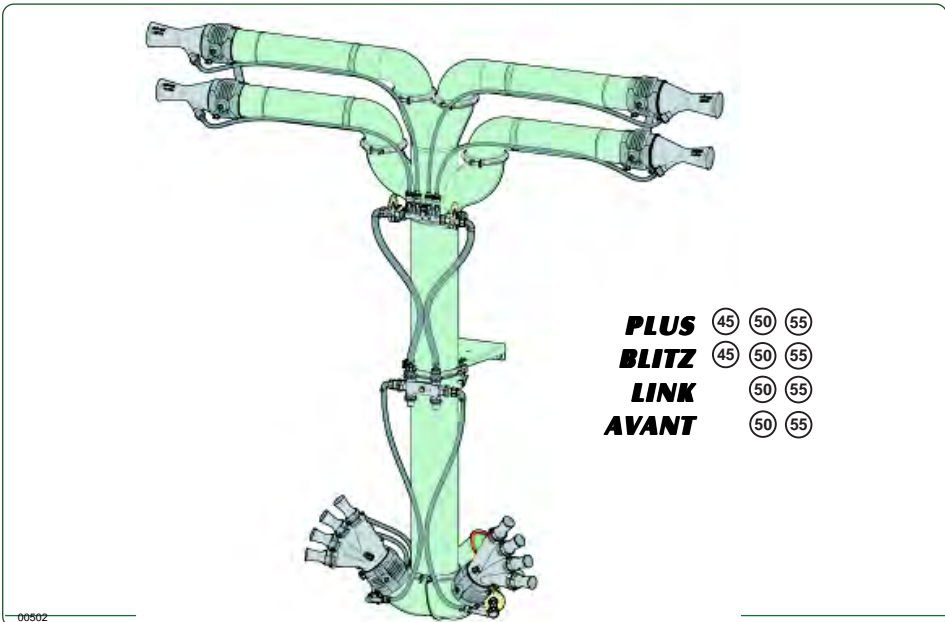

TCS. 2M 4C

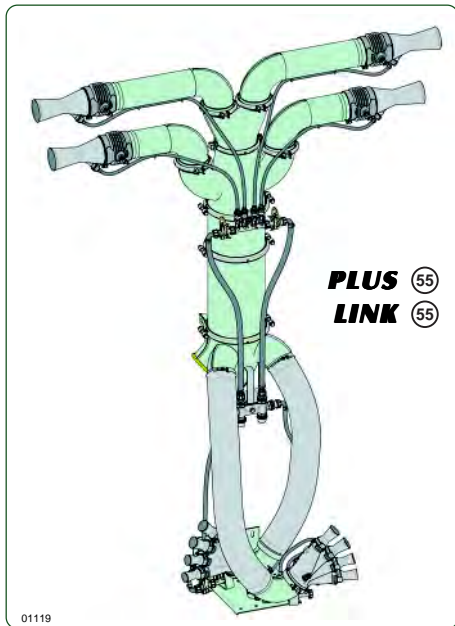

T. 2M 20L

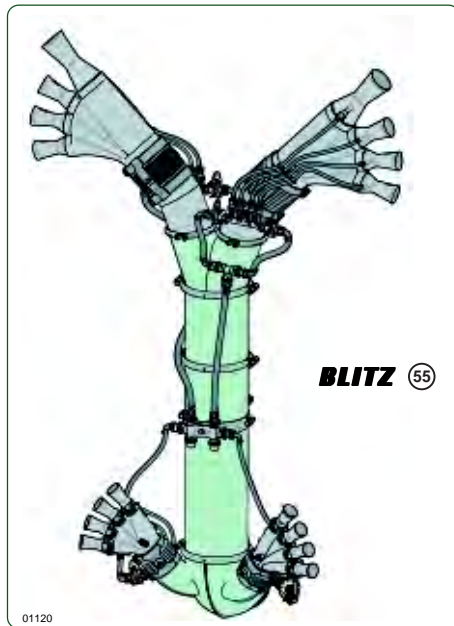

TCF. 2M 2M DOURO

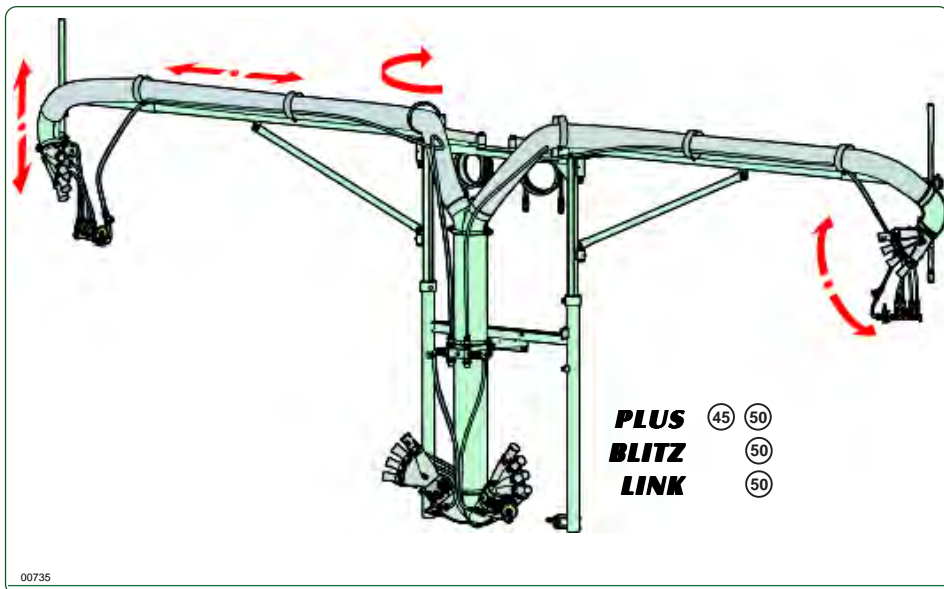

POTATOES SPRAYHEAD

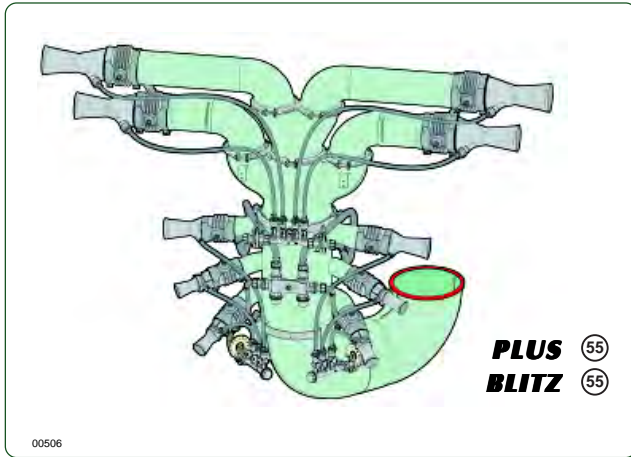

AVOMAC SPRAYHEAD

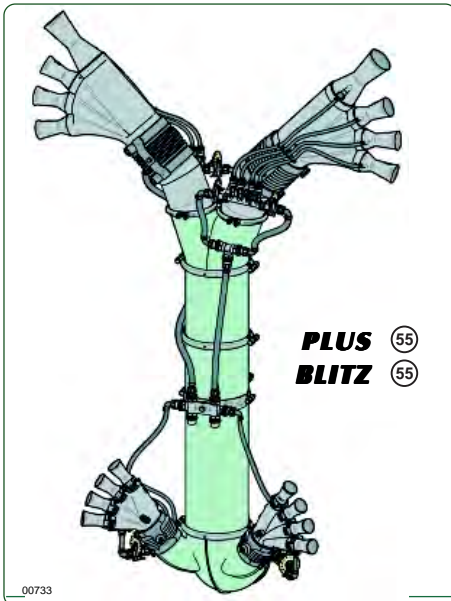

TOMATO SPRAYHEAD

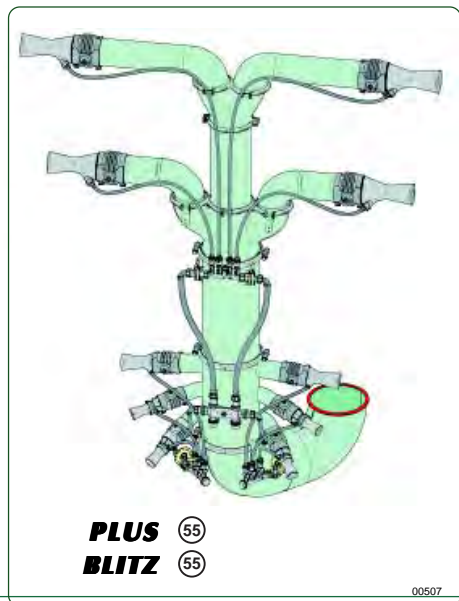

T. ROMAGNA

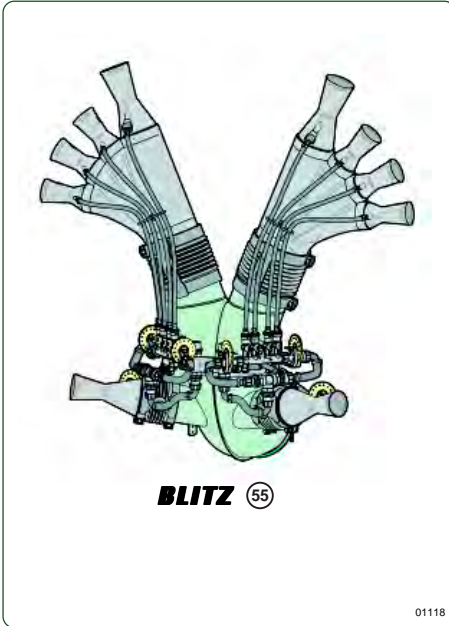

T. 4C 20L

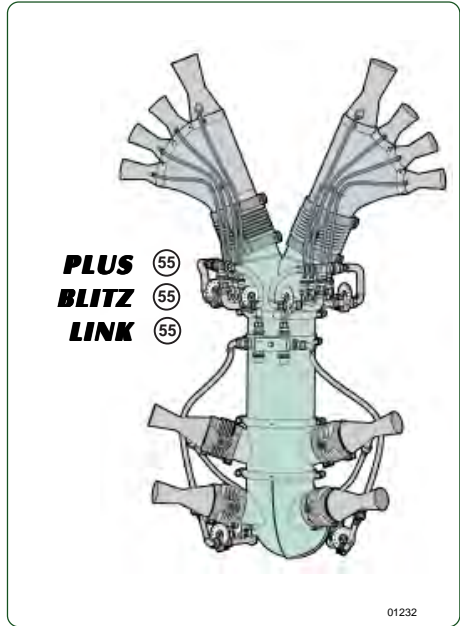

TCF. 2M 4C

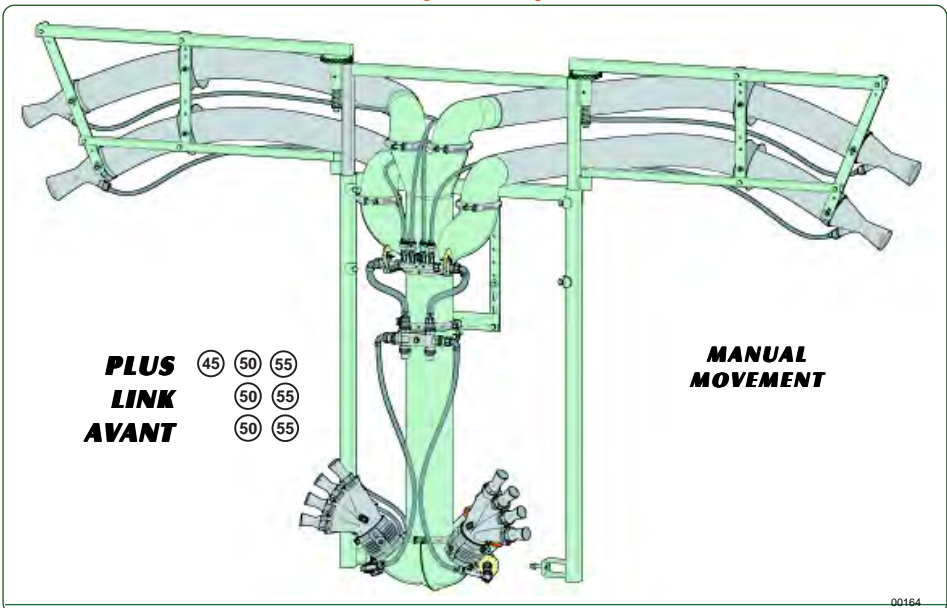

TCI. 2M 4C

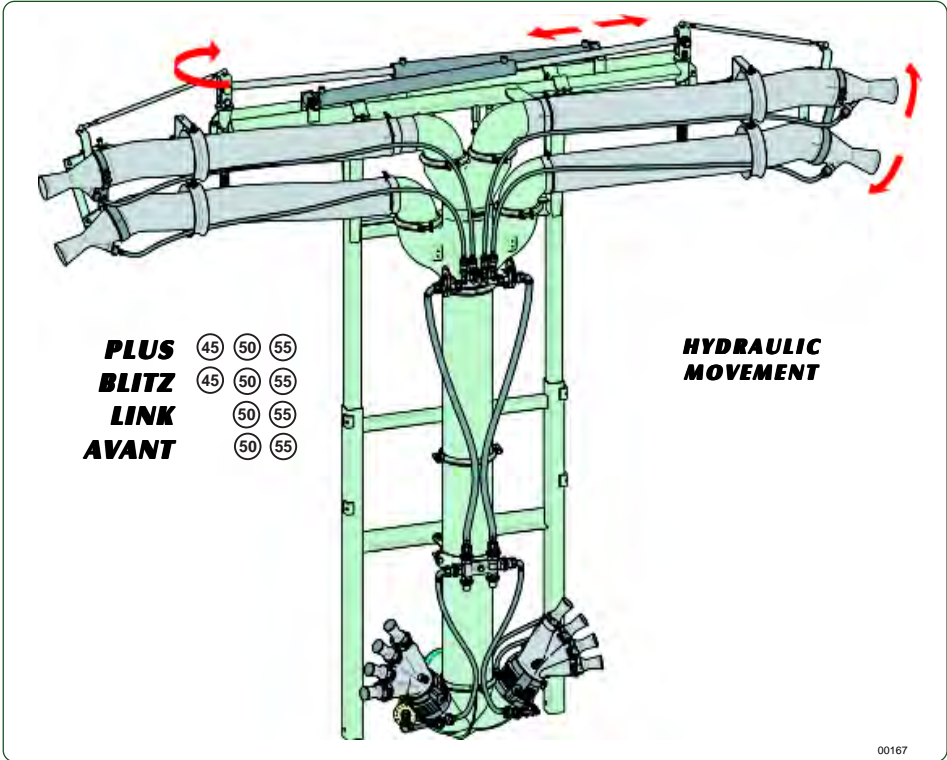

**COMPLETE BODY KIT
 2 HANDS WITH 2 NOZZLES EACH**

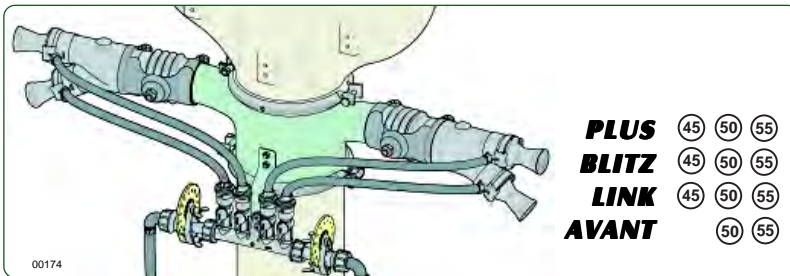

TOBACCO CANNON JET

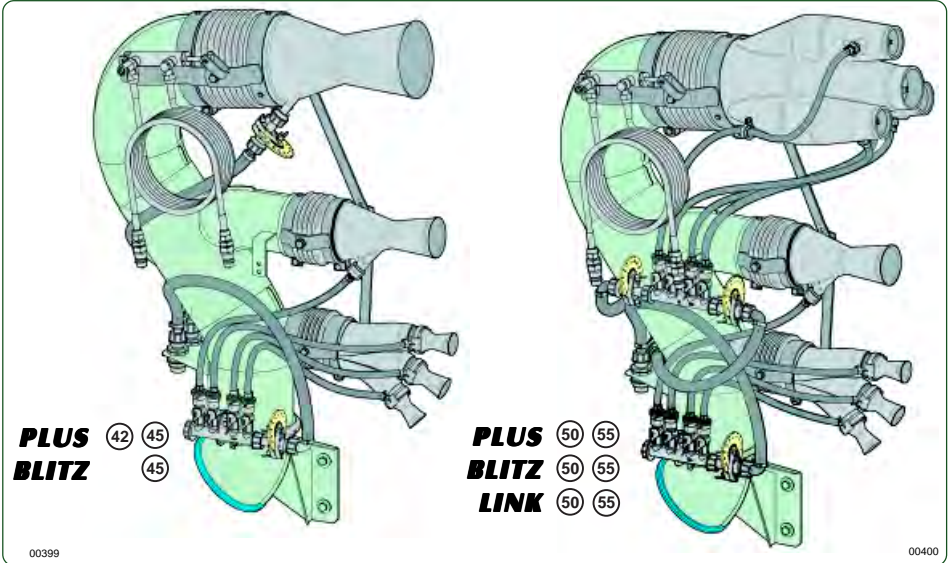

VERTICAL CANNON JET

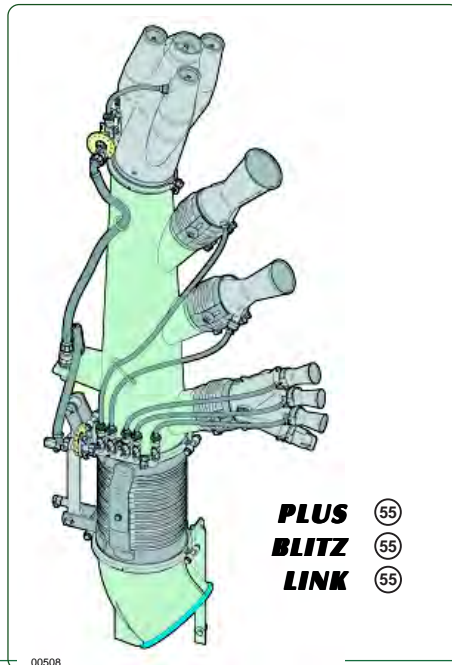

2.3 - IDENTIFICATION

In the table, the Sprayheads' identification codes are reported, associated with the model on which they can be mounted.

Description	Model	Part/Number	Weight (kg)
T.4+4 4+4 nozzles	Plus 42	T.4+4. 42.12	5,00
	Plus/Blitz 45	T.4+4. 45.12	5,00
	Plus/Blitz/Link 50	T.4+4. 50.12	5,00
T.5+5 5+5 nozzles	Plus 42	T.5+5. 42.12	6,00
	Plus/Blitz 45	T.5+5. 45.12	6,00
	Plus/Blitz/Link 50	T.5+5. 50.12	6,00
	Plus 55	T.5+5. 55P.12	34,00
	Blitz 55	T.5+5. 55T.12	
Extra charge for hydraulic movement T.4+4 - T.5+5	Plus 42-45-50 – Link 50	DIFF.I. 2M.01	7,50
	Blitz 45-50	DIFF.I. 2M.02	9,00
	Plus 55	DIFF.I. 2OL.01	9,00
	Blitz 55	DIFF.I. 2OL.02	9,00
STRASBURGO SPRAYHEAD 4+4 nozzles	Plus 42	T.ST4. 42P.12	9,00
	Plus 45	T.ST4. 45P.12	9,00
	Plus 50	T.ST4. 50P.12	9,50
	Blitz 45	T.ST4. 45T.12	5,00
	Blitz 50	T.ST4. 50T.12	5,00
TENDONE SPRAYHEAD 7 nozzles	Plus 42	T.TND .42.12	7,60
	Plus/Blitz 45	T.TND .45.12	7,60
	Plus/Blitz 50	T.TND .50.12	7,60
TENDONE SPRAYHEAD 9 nozzles	Plus 55	T.TND. 55P.12	12,80
	Blitz 55	T.TND. 55T.12	17,70
2 FISHTAILS SPRAHEAD			
3 sector narrow	Plus 45	T.2V3S. 45P.12	13,00
4 sector	Plus/Link 50	T.2V4. 50P.12	14,00
3 sector wide	Plus/Link 50	T.2V3L. 50P.12	14,00
8 sector	Plus 55	T.2V8. 55P.12	26,00
3 sector wide	Plus 55	T.2V3L. 55P.12	23,40
3 sector narrow	Blitz 45	T.2V3S. 45T.12	9,00
4 sector	Blitz 50	T.2V4. 50T.12	10,00
3 sector wide	Blitz 50	T.2V3L. 50T.12	9,00
3 sector wide	Blitz 55	T.2V3L. 55T.12	11,00
4 sector	Blitz 55	T.2V4. 55T.12	12,00
8 sector	Blitz 55	T.2V8. 55T.12	13,00
3 sector wide	Link 55	T.2V3L. 55S.12	50,00
4 FISHTAILS SPRAYHEAD			
2 sector	Plus - Link 50	T.4V.5 0P.12	
3 sector wide	Plus 55	T.4V.5 5P.12	75,00
3 sector wide	Link 55	T.4V.5 5S.12	
2 sector	Blitz 50	T.4V.5 0T.12	
3 sector wide	Blitz 50	T.4V.50 T. 10.12	65,00
3 sector wide	Blitz 55	T.4V.5 5T.12	58,00

Description	Model	Part/Number	Weight (kg)
6 FISHTAILS 3 fishtails each side	Blitz 55	T.6V.55T .12	64,00
	Blitz 55 Extra	T.6V.55T E.12	64,00
TC. 2M 2M 2 hands at 4 nozzles each side	Plus 45	TC.2M2M.45P.12	35,00
	Plus/Link 50	TC.2M2M.50P.12	35,50
	Plus 55	TC.2M2M.55P.12	64,00
	Link 55	TC.2M2M.55S.12	
	Blitz 45	TC.2M2M.45T.12	30,00
	Blitz 50	TC.2M2M.50T.12	30,00
	Blitz 55	TC.2M2M.55T.12	48,00
TCS. 2M 2M 2 hands at 4 nozzles each side	Plus 55	TCS.2M2M.55P.12	56,00
	Link 55	TCS.2M2M.55S.12	56,00
TC. 2M 2C 2 lower hands at 4 nozzles each and 2 upper cannons	Plus 45	TC.2M2C.45P.12	36,00
	Plus/Link 50	TC.2M2C.50P.12	37,00
	Plus 55	TC.2M2C.55P.12	67,00
	Link 55	TC.2M2C.55S.12	
	Blitz 45	TC.2M2C.45T.12	31,00
	Blitz 50	TC.2M2C.50T.12	31,00
	Blitz 55	TC.2M2C.55T.12	53,00
TCS. 2M 2C 2 lower hands at 4 nozzles each and 2 upper cannons	Plus 55	TCS.2M2C.55P.12	40,00
	Link 55	TCS.2M2C.55S.12	51,00
Extra charge for the hydraulic movement of the upper nozzles/cannons TC./TCS. 2M 2M TC./TCS. 2M 2C	Plus/Link/Blitz A 45-50	DIFF.I.2C.TC.01	9,00
	Blitz 45-50	DIFF.I.2C.TC.02	10,5
	Plus/Link55/Blitz A 55	DIFF.I.2C.TC.03	7,00
	Blitz 55	DIFF.I.2C.TC.04	8,50
Extra charge for the electrical movement of the upper nozzles/cannons TC./TCS. 2M 2M TC./TCS. 2M 2C	Plus/Link/Blitz A 45-50	DIFF.E.2C.TC.01	1,50
	Blitz 45-50	DIFF.E.2C.TC.02	1,50
	Plus/Link55/Blitz A 55	DIFF.E.2C.TC.03	1,50
	Blitz 55	DIFF.E.2C.TC.04	1,50
TC. 2M 4C 2 lower hands at 4 nozzles 4 upper cannons	Plus 45	TC.2M4C.45P.12	44,00
	Plus/Link 50	TC.2M4C.50P.12	55,00
	Plus 55	TC.2M4C.55P.12	74,00
	Link 55	TC.2M4C.55S.12	
	Blitz 45	TC.2M4C.45T.12	48,00
	Blitz 50	TC.2M4C.50T.12	48,00
	Blitz 55	TC.2M4C.55T.12	69,00
TCS. 2M 4C 2 lower hands at 4 nozzles + 4 upper cannons.	Plus 55	TCS.2M4C.55P.12	70,00
	Link 55	TCS.2M4C.55S.12	70,00

TABE_002

Description	Model	Part/Number	Weight (kg)
Extra charge for the hydraulic movement of the upper cannons TC./TCS. 2M 4C	Plus/Link/Blitz A	DIFF.I.4C.TC.01	2,30
	Blitz	DIFF.I.4C.TC.02	5,00
Extra charge for the electrical movement of the upper cannons TC./TCS. 2M 4C	Plus/Link/Blitz A	DIFF.E.4C.TC.01	2,50
	Blitz	DIFF.E.4C.TC.02	2,50
2 hands at 2 nozzles kit TC./TCS. 2M2C - 2M4C	All 45/50	K.2M2D.175.112	5,00
	Plus/Blitz 55	K.2M2D.250.12	7,00
2 hands at 2 nozzles kit TCS. 2M2C - 2M4C	Link 55	K.2M2D.A250.12	6,50
TCF. 2M 2M - DOURO 4 hands at 4 nozzles with hydr.movement for arms folding Interrow distance 1,80 a 2,30 m	Plus 45	TCF.2M2M.45P.12	88,00
	Plus 50	TCF.2M2M.50P.12	126,00
	Link 50	TCF.2M2M.50S.12	95,00
	Blitz 50	TCF.2M2M.50T.12	90,00
TCF. 2M 2M - DOURO 4 hands at 4 nozzles with hydr.movement for arms folding Interrow distance 2,30 a 3,50 m	Plus 50	TCF.2M2M.50P12L	140,00
	Link 50	TCF.2M2M.50S12L	140,00
	Blitz 50	TCF.2M2M.50T12L	184,00
TCF. 2M 4C 2 hands at 4 nozzles 4 flex. cannons	Plus 45	TCF.2M4C.A45P12	105,00
	Plus 50	TCF.2M4C.A50P12	108,00
	Plus 55	TCF.2M4C.A55P12	
	Link 50	TCF.2M4C.A50S12	72,00
	Link 55	TCF.2M4C.A55S12	72,00
Hydraulic kit for arms folding TCF 2M 4C Sprayheads	Plus	K.2.TCF.P01	8,00
	Link	K.2.TCF.A01	8,50
Extra charge for the electrical movement of the upper cannons Sprayhead TCF 2M 4C	Plus/Link	DIFF.E.4C.TCF01	4,00
TCI. 2M 4C 2 hands at 4 lower nozzles 4 upper cannons hydraulic movement for the width adjustment, vertical orientation of the cannons, opening and closing of the external sections	Plus 45	TCI.2M4C.45P12	128,00
	Plus 50	TCI.2M4C.50P12	128,00
	Plus 55	TCI.2M4C.55P12	162,00
	Link 50	TCI.2M4C.50S12	152,00
	Link 55	TCI.2M4C.55S12	167,00
	Blitz 45	TCI.2M4C.45T12	128,00
	Blitz 50	TCI.2M4C.50T12	143,00
Blitz 55	TCI.2M4C.55T12	153,00	

Description	Model	Part/Number	Weight (kg)
TCIS. 2M 4C 2 hands at 4 lower nozzles 4 upper cannons hydraulic movement for the width adjustment, vertical orientation of the cannons, opening and closing of the external sections	Plus 55	TCIS.2M4C.55P12	162,00
	Link 55	TCIS.2M4C.55S12	167,00
2 hands at 2 nozzles kit TCF - TCI	All 45/50	K.2M2D.175.12	4,00
	Plus/Blitz 55	K.2M2D.250.12	7,00
2 hands at 2 nozzles kit TCIS	Link 55	K.2M2D.A250.12	6,50
Extra charge for the electrical movement of the upper cannons TCI	Plus/Link/Blitz A	DIFF.E.4C.TCI01	2,50
	Blitz	DIFF.E.4C.TCI02	3,80
T. 4M 2 upper hands at 2 nozzles 2 lower hands at 2 nozzles	Plus 42	T.4M.42P.1 2	28,00
	Plus 45	T.4M.45P.1 2	28,00
T. 6M 6 hands at 2 nozzles	Plus 42	T.6M2D.42P. 12	34,00
	Plus 45	T.6M2D.45P. 12	34,00
	Plus 50	T.6M2D.50P. 12	34,70
COFFEE SPRAYHEAD 2 lower hands at 4 nozzles 2 upper hands at 5 nozzles	Plus 45	T.CA.45P.1 2	30,00
	Plus/Link 50	T.CA.50P.1 2	30,00
	Blitz 45	T.CA.45T.1.2	28,00
	Blitz 50	T.CA.50T.1.2	28,00
Potato Sprayhead with 90°elbow D. 250mm	Blitz 55	T.PT.55T.1 2	47,00
Potato Sprayhead with 180°elbow D. 250mm	Plus 55	T.PT.55P.1 2	64,00
Tomato Sprayhead with 90°elbow D. 250mm	Blitz 55	T.PM.55T.1 2	60,00
Tomato Sprayhead with 180°elbow D. 250mm	Plus 55	T.PM.55P.1 2	74,00

Description	Model	Part/Number	Weight (kg)
OLIVE SPRAYHEAD without elbow	Plus 42	T.OL.000.42.12	8,00
	Plus/Blitz 45	T.OL.000.45.12	9,25
	Plus/Blitz/Link 50	T.OL.000.50.12	10,00
OLIVE SPRAYHEAD with 45° elbow Only for the the models without spray-line rinsing tank system	Plus 42	T.OL.045.42.12	13,00
	Plus 45	T.OL.045.45.12	13,00
	Plus 50	T.OL.045.50.12	15,00
	Plus 55	T.OL.045.55.12	25,00
OLIVE SPRAYHEAD with 180° elbow D. 250mm	Plus 55	T.OL.180.55.12	31,00
OLIVE SPRAYHEAD with 600mm extension D. 175mm	Blitz 45	T.OL.P06.45.12	15,00
	Blitz 50	T.OL.P06.50.12	15,00
OLIVE SPRAYHEAD with 800mm extension D. 175mm	Plus 45	T.OL.P08.45.12	18,50
	Plus/Link 50	T.OL.P08.50.12	18,50
OLIVE SPRAYHEAD with 90°elbow and 600mm extension D. 250mm	Blitz 55	T.OL.P06.55.12	28,00
Extra charge for hydraulic orientation Olive Sprayhead	Plus/Link	DIFF.I.OL.01	4,00
	Blitz	DIFF.I.OL.02	5,00
DOUBLE OLIVE SPRAYHEAD with 180° elbow	Plus 55	T.2OL.180.55.12	34,00
DOUBLE OLIVE SPRAYHEAD with 90° elbow	Blitz 55	T.2OL.090.55.12	23,00
ROMAGNA SPRAYHEAD 2 lower cannons and upper double olive	Blitz 55	T.2C2OL.55T.12	55,50
T.4C 2OL 4 lower cannons and upper double olive	Plus 55	T.4C2OL.55P.12	
	Blitz 55	T.4C2OL.55T.12	
	Link 55	T.4C2OL.55S.12	
T.2M 2OL 2 lower hands and upper double olive	Blitz 55	T.2M2OL.55T.12	36,00
Extra Charge for hydraulic orientation T. Double Olive – T.Romagna T.2M.2OL	Plus 55	DIFF.I.2OL.01	9,00
	Blitz 55	DIFF.I.2OL.02	10,50
AVOMAC SPRAYHEAD	Plus 55	T.2OL2M.55P.12	69,50
	Blitz 55	T.2OL2M.55T.12	55,50

Description	Model	Part/Number	Weight (kg)
Tobacco cannon without elbow with hydraulic piston	Plus 42	T.GC.00.42P.1 2	22,00
	Plus 45	T.GC.00.45P.1 2	22,00
	Plus/Link 50 Multiple Diffusers	T.GC.00.50P.1 2	22,00
	Blitz 45	T.GC.00.45T.1 2	22,00
	Blitz 50 Multiple Diffusers	T.GC.00.50T.1 2	23,50
Tobacco cannon with 45° elbow and hydraulic piston Only for the the models without spray line rinsing tank system	Plus 42	T.GC.045.42.12	26,00
	Plus 45	T.GC.045.45.12	26,00
	Plus 50	T.GC.045.50.12	27,00
	Plus/Link 55 Multiple Diffusers	T.GC.045.55.12	33,00
Tobacco cannon with 800mm extension D. 175mm and hydraulic piston	Plus 45	T.GC.P08.45.1 2	32,00
Tobacco cannon (Multiple diffusers) 800mm extension D. 175mm and hydraulic piston	Plus 50 / Link 50	T.GC.P08.50.1 2	32,50
Tobacco cannon with 180° elbow D. 250mm and hydraulic piston	Plus 55 Multiple Diffusers	T.GC.180.55.1 2	44,00
Tobacco cannon with 180°elbow 800mm extension D. 250mm and hydraulic piston	Plus 55 Multiple Diffusers	T.GC.180.55P. 12	54,00
Tobacco cannon with 600mm extension D. 175mm and hydraulic piston	Blitz 45	T.GC.P06.45.1 2	58,50
	Blitz 50 Multiple Diffusers	T.GC.P06.50.1 2	60,00
Tobacco cannon with 90° elbow 600mm extension D. 250mm and hydraulic piston	Blitz 55 Multiple Diffusers	T.GC.P06.55.1 2	70,00
Vertical cannon with 180° elbow 800mm extension D. 250mm and hydraulic piston	Plus 55	T.GCV.180.55P 12	59,00
Vertical cannon with 45° elbow and hydraulic piston	Plus/Link 55	T.GCV.045.1 2	48,00
Vertical cannon with 90° elbow 800mm extension D. 250mm and hydraulic piston	Blitz 55	T.GCV.P08.1 2	54,00

Wrap-a-round sprayheads (see specific publications)



Description		Model	Part/Number	Weight (kg)
Wrap-a-round boom Hydraulically controlled 2 rows 4 hands at 3 nozzles 4 hands at 2 nozzles	Interrow (mt.) 1,50 ÷ 1,90	Blitz 50 lt.800/1000	TS5.4M4M.J50M12	
Wrap-a-round boom Hydraulically controlled 3 rows 6 hands at 3 nozzles 6 hands at 2 nozzles	Interrow (mt.) 1,50 ÷ 1,90	Blitz 50 lt.800/1000	TS5.6M6M.J50M12	
Wrap-a-round boom Hydraulically controlled 2 rows 12 hands at 2 nozzles	Interrow (mt.) 1,50 ÷ 1,90	Blitz 50 lt.800/1000	TS5.12M.J50M12	
Wrap-a-round boom Hydraulically controlled 3 rows 18 hands at 2 nozzles	Interrow (mt.) 1,50 ÷ 1,90	Blitz 50 lt.800/1000	TS5.18M.J50M12	
Wrap-a-round boom Hydraulically controlled 2 rows 4 hands at 3 nozzles 4 hands at 2 nozzles	Interrow (mt.) 1,80 ÷ 2,20	Blitz 50 lt.800/1000	TS5.4M4M.A50M12	
Wrap-a-round boom Hydraulically controlled 3 rows 6 hands at 3 nozzles 6 hands at 2 nozzles	Interrow (mt.) 1,80 ÷ 2,20	Blitz 50 lt.800/1000	TS5.6M6M.A50M12	430,00
Wrap-a-round boom Hydraulically controlled 2 rows 12 hands at 2 nozzles	Interrow (mt.) 1,80 ÷ 2,20	Blitz 50 lt.800/1000	TS5.12M.A50M12	
Wrap-a-round boom Hydraulically controlled 3 rows 18 hands at 2 nozzles	Interrow (mt.) 1,80 ÷ 2,20	Blitz 50 lt.800/1000	TS5.18M.A50M12	440,00

Description		Model	Part/Number	Weight (kg)
Wrap-a-round boom Hydraulically controlled 2 rows 4 hands at 4 nozzles	Interrow (mt.) 2,30 ÷ 3,10	Blitz 50 lt.1000	TS5.4M.B50M12	
		Blitz 50 lt.1500	TS5.4M.B50D12	
Wrap-a-round boom Hydraulically controlled 2 rows 4 hands at 4 nozzles	Interrow (mt.) 2,30 ÷ 3,10	Blitz 55 lt.1000	TS5.4M.B55M12	
		Blitz 55 lt.1500/2000	TS5.4M.B55D12	
Wrap-a-round boom Hydraulically controlled 3 rows 6 hands at 4 nozzles	Interrow (mt.) 2,30 ÷ 3,10	Blitz 50 lt.1000	TS5.6M.B50M12	476,00
		Blitz 50 lt.1500	TS5.6M.B50D12	
Wrap-a-round boom Hydraulically controlled 3 rows 6 hands at 4 nozzles	Interrow (mt.) 2,30 ÷ 3,10	Blitz 55 lt.1000	TS5.6M.B55M12	484,00
		Blitz 55 lt.1500/2000	TS5.6M.B55D12	
Wrap-a-round boom Hydraulically controlled 3 rows 6 hands at 4 nozzles	Interrow (mt.) 2,30 ÷ 3,10	Blitz 55 lt.1000	TS5.4M4C.B55M12	
		Blitz 55 lt.1500/2000	TS5.4M4C.B55D12	
Wrap-a-round boom Hydraulically controlled 3 rows 6 hands at 4 nozzles 4 cannons 14/120	Interrow (mt.) 2,30 ÷ 3,10	Blitz 55 lt.1000	TS5.6M6C.B55M12	
		Blitz 55 lt.1500/2000	TS5.6M6C.B55D12	
Wrap-a-round boom Hydraulically controlled 2 rows 4 hands at 4 nozzles	Interrow (mt.) 3,00 ÷ 4,20	Blitz 50 lt.1500	TS5.4M.C50D12	
Wrap-a-round boom Hydraulically controlled 2 rows 4 hands at 4 nozzles	Interrow (mt.) 3,00 ÷ 4,20	Blitz 55 lt.1500/2000	TS5.4M.C55D12	
Wrap-a-round boom Hydraulically controlled 3 rows 6 hands at 4 nozzles	Interrow (mt.) 3,00 ÷ 4,20	Blitz 50 lt.1500	TS5.6M.C50D12	
Wrap-a-round boom Hydraulically controlled 3 rows 6 hands at 4 nozzles	Interrow (mt.) 3,00 ÷ 4,20	Blitz 55 lt.1500/2000	TS5.6M.C55D12	531,00
Wrap-a-round boom Hydraulically controlled 3 rows 6 hands at 4 nozzles	Interrow (mt.) 3,00 ÷ 4,20	Blitz 55 lt.1500/2000	TS5.4M4C.C55D12	535,00
Wrap-a-round boom Hydraulically controlled 3 rows 6 hands at 4 nozzles 4 cannons 14/120	Interrow (mt.) 3,00 ÷ 4,20	Blitz 55 lt.1500/2000	TS5.6M6C.C55D12	
Extra Charge for 5 ways electro-hydraulic gearbox with electrical remote control and hydr.oil hoses			DIFF.C.EI.5	
Extra charge for 4 nozzles hand in alternative to the upper cannons			DIFF.M4D.12	

Sprayheads for sprayer homologated for use on public roads

Description	Sprayer	Part/Number	Weight (kg)
T.5+5	Blitz 50 lt. 1000	T.5+5.50.12	6,00
TC 2M 2C 2 lower hands at 4 nozzles each and 2 upper cannons	Blitz 50 lt. 1000	TC.2M2C.50T.12	30,00
	Blitz 55 lt. 1000	TC.2M2C.55T.12	52,00
TC 2M 4C 2 lower hands at 4 nozzles each and 4 upper cannons	Blitz 50 lt. 1000	TC.2M4C.50T.12	48,00
	Blitz 55 lt. 1000	TC.2M4C.55T.12	58,00
TCI 2M 4C (hydraulic movement) 2 hands at 4 lower nozzles 4 upper cannons	Blitz 50 lt. 1000	TCI.2M4C.50T12	143,00
	Blitz 55 lt. 1000/1500	TCI.2M4C.55T12	170,00
2 FISHTAILS SPRAYHEAD	Blitz 50 lt. 1000	T.2V3L.50T.12	8,00
	Blitz 55 lt. 1000	T.2V3L.55T.12	8,00
	Blitz 55 lt. 1000/1500	T.2V4.55T.12	8,00
4 FISHTAILS SPRAYHEAD	Blitz 55 lt. 1000/1500	T.4V.55T.12	58,00
DOUBLE OLIVE SPRAYHEAD	Blitz 55 lt. 1000/1500	T.2OL.090.55.12	21,00
T. 2M2OL	Blitz 55 lt. 1000/1500	T.2M2OL.55T.12	36,00
T.2C2OL ROMAGNA	Blitz 55 lt. 1500	T.2C2OL.55T.12	25,00

TABT_003

Airbooms for 3-point mounted sprayers

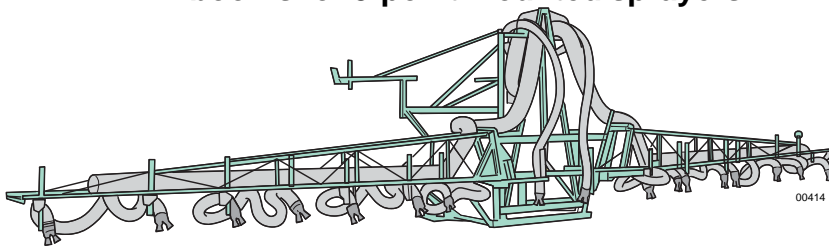

Description	Model	Part/Number	Weight (kg)
5 meters manual boom 8 outlets at 2 nozzles each	Plus 45	BM.08.2.02	
7 meters manual boom 10 outlets at 2 nozzles each	Plus 45/50	BM.10.2.02	111,00
12 meters pneumatic boom 18 outlets at 2 nozzles each Section closing,height adjustment and section level hydraulically controlled	Plus 50	B18.2.66.50.02	
	Plus 55-S-E	B18.2.66.55.02	
Extra Charge for 5 ways electro-hydraulic gearbox with electrical remote control and hydraulic oil hoses	Boom mt. 12	DIFF.C.EI.5	

TABT_010

Sprayheads for Blitz Avant sprayer

Description	Sprayer	Part/Number	Weight (kg)
TC 2M 2C 2 lower hands +2 upper cannons	Blitz A 50	TC.2M2C.A50T12	35,00
	Blitz A 55	TC.2M2C.A55T12	50,00
TC 2M 4C 2 lower hands+ 4 upper cannons	Blitz A 50	TC.2M4C.A50T12	45,00
	Blitz A 55	TC.2M4C.A55T12	60,00
TC 2M 2M 2 lower hands +2 upper hands	Blitz A 50	TC.2M2M.A50T12	36,00
	Blitz A 55	TC.2M2M.A55T12	51,00
TCF 2M 4C 2 lower hands+ 2 flex cannons	Blitz A 50	TCF.2M4C.A50T12	75,00
	Blitz A 55	TCF.2M4C.A55T12	98,00
Hydraulic kit for arms folding	TCF Sprayheads	K.2.TCF.A01	8,50
TCI 2M 4C 2 lower hands at 4 nozzles 4 upper cannons	Hydraulic movement for the width adjustment, vertical movement of the cannons opening and closing of the external sections		
	Blitz A 50	TCI.2M4C.A50T12	128,00
	Blitz A 55	TCI.2M4C.A55T12	160,00
2 hands 2 nozzles kit TC/TCF/TCI	Blitz A 50	K.2M2D.175.112	5,00
	Blitz A 55	K.2M2D.A250.12	7,00

TAB.01

2.4 - CUSTOMER SERVICE

C.I.M.A. S.p.A. is at complete disposal of its customers for every type of intervention. The names and addresses of its customer service network, both in Italy and abroad, can be obtained by contacting:

C.I.M.A. S.p.A. - 27040 Montù Beccaria - Loc. Molino Quaroni (PV) - ITALY
+39-0385-246636 - fax +39-0385-246637
e.mail service@cima.it

2.5 - SAFETY WARNINGS



IT IS ABSOLUTELY NECESSARY TO CAREFULLY OBSERVE BOTH THE INDICATIONS SUPPLIED IN THIS MANUAL AND THE SAFETY RULES CONTAINED IN THE SPRAYER OPERATION AND MAINTENANCE INSTRUCTIONS MANUAL.

- stop the tractor engine and remove the ignition key from the control panel before to mount the distribution device.
- before use, check that the distribution device was correctly mounted to the sprayer and secured to it.

3 DISTRIBUTION DEVICES' COMPONENTS 3

3.1 - HANDS

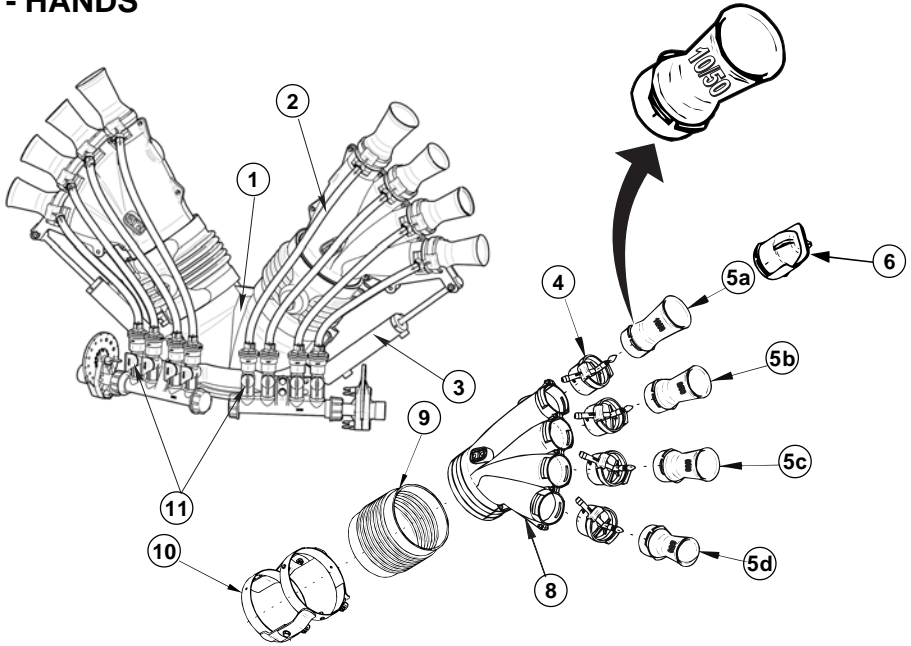

LEGEND

1. SPRAYHEADBODY
2. DIFFUSERS FEEDING TUBE
3. HYDRAULIC CYLINDER
4. FAST COUPLING TUBE-CARRIER FITTING WITH OLIVE STOPPER
5. DIFFUSER
6. AIR FLOW CLOSING CAP
(upon request)
7. Y JOINT
8. DIFFUSER-CARRIER SIDEBODY
9. FLEXIBLE SLEEVE
10. DOUBLE JOINT CLAMP
11. DELIVERY CLOSING COCK

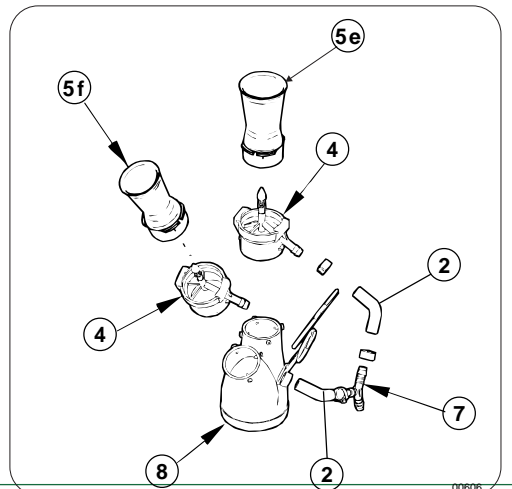

00606

DELIVERY CLOSING COCK (11)

It either opens or closes the delivery of the liquid into the diffuser. The cock is open, when the control wing is positioned towards the outlet flow of the liquid. It is closed, when the wing is 90° rotated. In order to stop also the air flow when the cock is closed, the diffuser has to be replaced with the cap (4), to be supplied upon request.

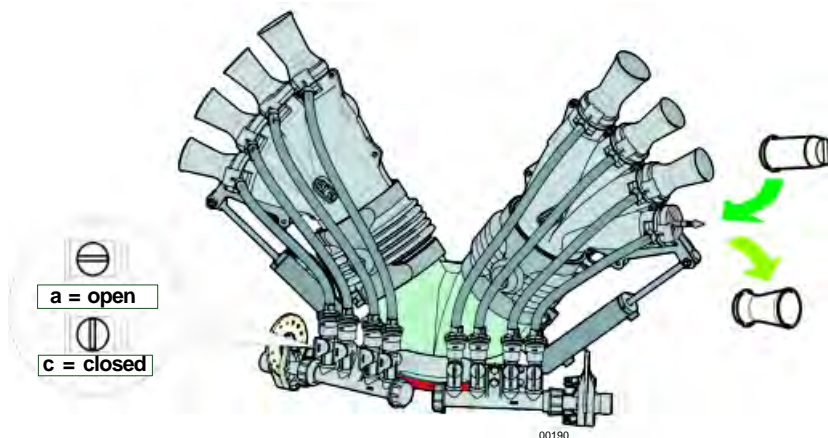

HYDRAULIC ORIENTATION (3)

The hands' diffuser-carrier side body can be equipped, either as a standard supply or as an option, with an hydraulic kit to be coupled to the power outlets of the tractor, through which the sprayhead vertical orientation movements can be remotely controlled in a separate way either on the right side or on the left one.

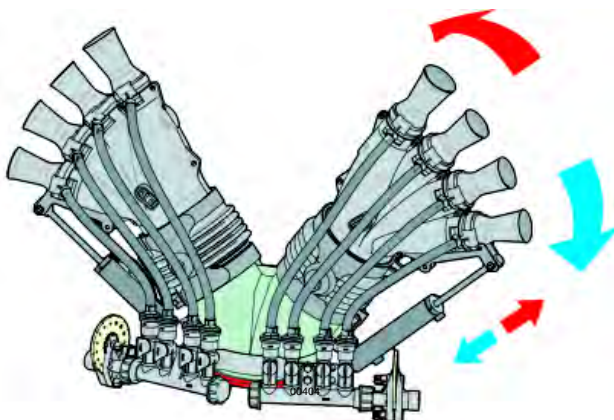

DIFFUSERS (5)

The single diffuser is characterized by a couple of numbers: the first one indicates the area expressed in cm^2 of the outlet section of the same one, while the second one is the diameter expressed in mm of the junction. The diffusers are replaceable and interchangeable the one with the other only on the same side body, in such a way to keep the total section unchanged.

EXECUTION FOR THE DIFFUSERS' REMOVAL AND MOUNTING: rotate the diffuser 90° in order to remove it. Introduce into the seat the new one and rotate it: a click will assure that the operation was carried out correctly.

The diffusers have different outlet sections and are chosen according with the type of sprayer on which the sprayhead is employed (see point 5.1).

AIR FLOW CLOSING CAP (6) (upon request)

The cap is mounted in place of the diffuser on which the delivery of the liquid is closed by acting on the diffuser cock.

DOUBLE JOINT CLAMP (10)

By acting on the 2 external nuts, it is possible to either rotate upwards and downwards or to move backwards the diffuser-carrier side bodies. On the joint clamp is obtained or applied a graduated scale that indicates the position of the nozzle.

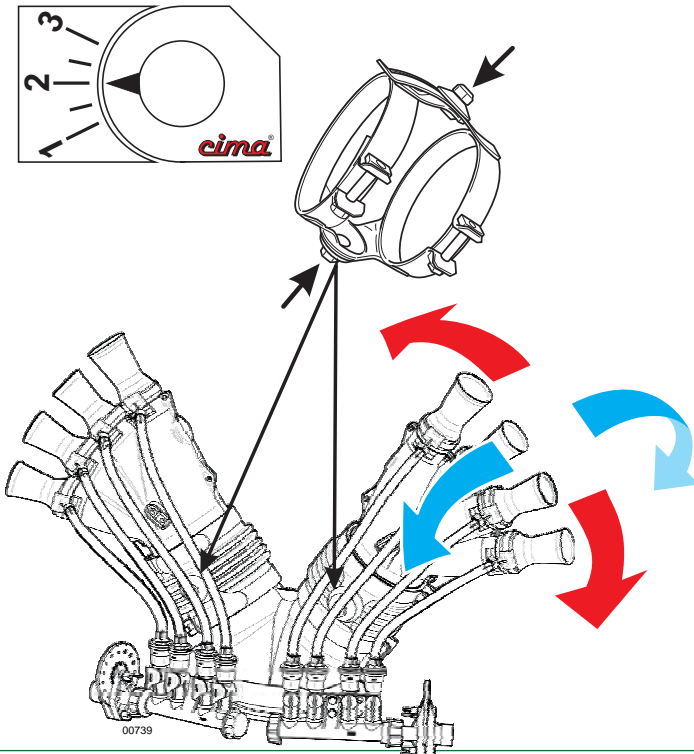

3.2 - CANNONS JET

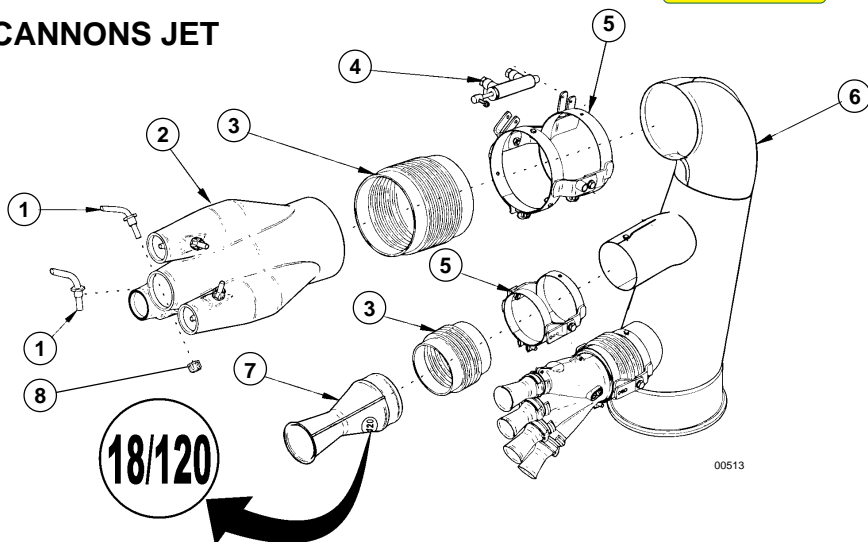

LEGEND

- | | |
|----------------------------|------------------------------------|
| 1. DIFFUSERS' FEEDING TUBE | 5. DOUBLE JOINT CLAMP |
| 2. MULTIPLE CANNON BODY | 6. PRAYHEAD BODY/AIR DELIVERY DUCT |
| 3. FLEXIBLE SLEEVE | 7. CANNON DIFFUSER |
| 4. HYDRAULIC CYLINDER | 8. FEEDING TUBE FASTENING RING NUT |

HYDRAULIC ORIENTATION (4)

The sprayhead with cannons can be equipped, as a standard supply or as an option, with a hydraulic kit to be coupled to the power outlets of the tractor, through which the sprayhead vertical orientation movements can be remotely controlled.

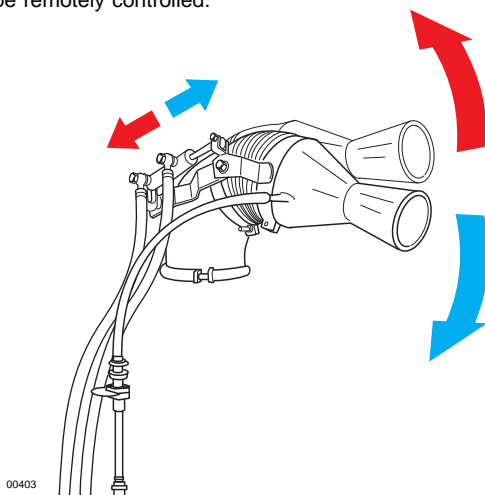

3.3 - FISHTAILS

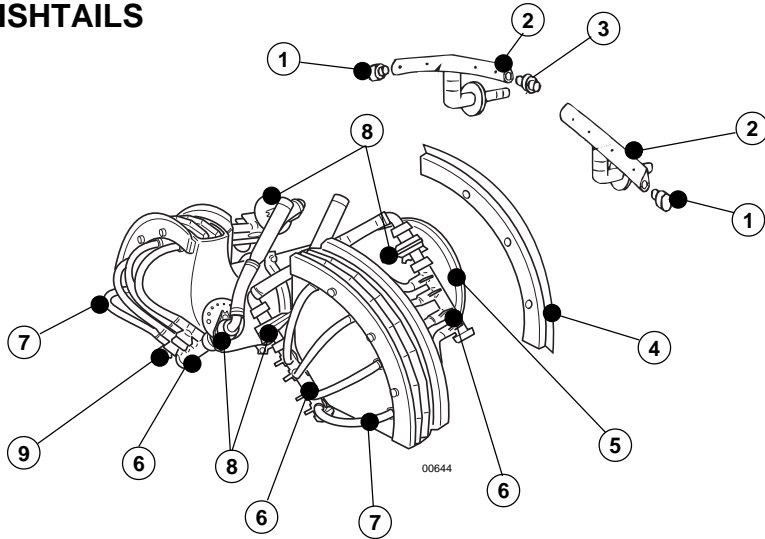

LEGEND

- | | |
|---------------------------------|---------------------------|
| 1. CLOSING CAP | 6. DISTRIBUTOR |
| 2. FISHTAIL FEEDING SECTOR TUBE | 7. DIFFUSERS FEEDING TUBE |
| 3. CONNECTING PIPE FITTING | 8. ROTARY DISC REGULATOR |
| 4. FISHTAIL GUARD | 9. DELIVERY STOPCOCK |
| 5. SPRAYHEAD BODY | |

3.4 - VARIOUS COMPONENTS

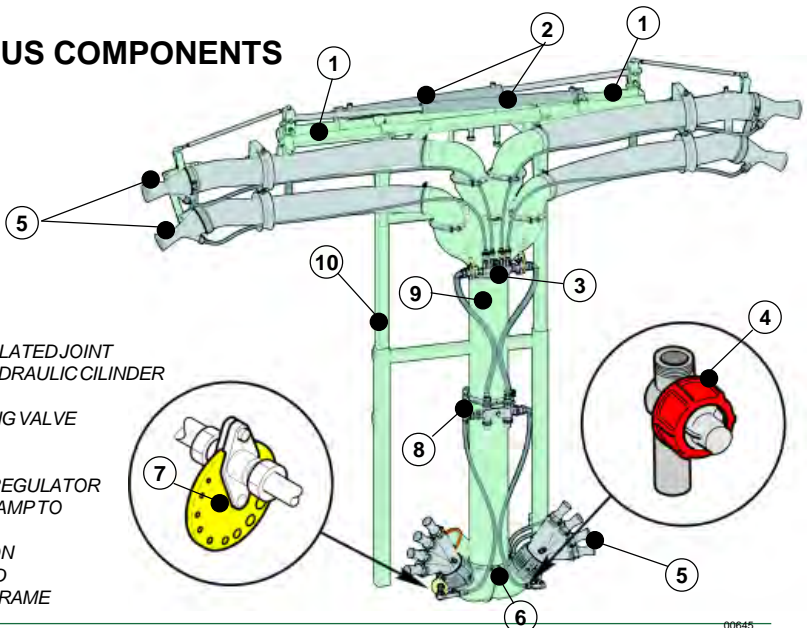

LEGEND

- | |
|------------------------------------|
| 1. FRAME ARTICULATED JOINT |
| 2. MOVEMENT HYDRAULIC CYLINDER |
| 3. DISTRIBUTOR |
| 4. DROP-STOPPING VALVE |
| 5. DIFFUSERS |
| 6. COLLAR |
| 7. ROTARY DISC REGULATOR |
| 8. FASTENING CLAMP TO THE SPRAYER |
| 9. PIPE EXTENSION |
| 10. FASTENING AND SUPPORTING FRAME |

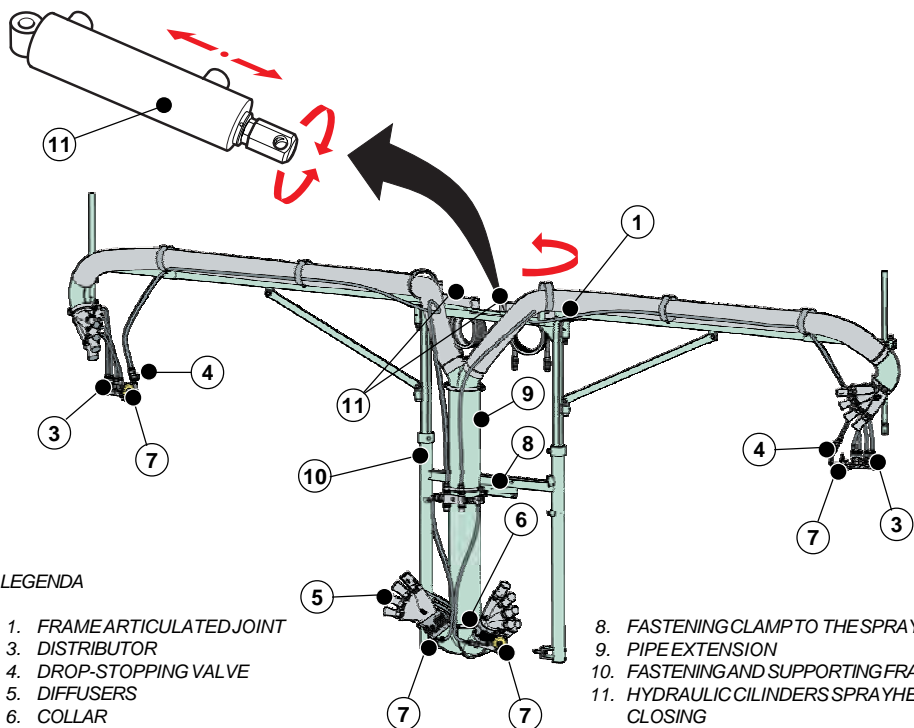

LEGENDA

1. FRAME ARTICULATED JOINT
3. DISTRIBUTOR
4. DROP-STOPPING VALVE
5. DIFFUSERS
6. COLLAR
7. ROTARY DISC REGULATOR

8. FASTENING CLAMP TO THE SPRAYER
9. PIPE EXTENSION
10. FASTENING AND SUPPORTING FRAME
11. HYDRAULIC CYLINDERS SPRAYHEAD CLOSING

CALIBRATION DISC (7)

Two flanges (1), kept in position by two throttle nuts (2) lock the disc (5) with calibrated holes, numbered from 1 to 15. **A slot (4) machined on the edge allows to exactly position the hole to be used.**

Its number has to appear in the semicircular seat of the flange. The disc rotation is obtained by loosening for a few rounds the throttle nuts. When the operation is over, carefully tighten the nuts back.

In order to determine the capacity, strictly follow the indications supplied in the publication "The low volume – Instructions for regulating the sprayer".

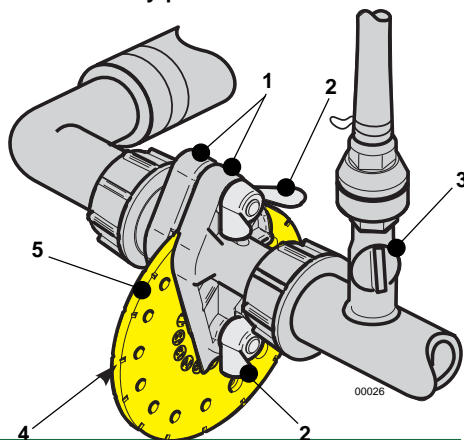

LEGEND

1. LOCKING FLANGES
2. THROTTLE NUT
3. DELIVERY STOPPING COCK
4. POSITIONING SLOT
5. ROTATING DISC WITH CALIBRATED HOLES

In some special cases, the delivery of the capacities required for the treatment is realized by the regulator directly mounted on the drop-stopping valve of the sprayhead feeding tube and consists of a metal pin provided with a calibrated hole.

In those cases, the sprayhead is supplied complete with a set of plates, with holes having a different diameter, for every regulator.

Usually, the plates mounted on the unit supply are the most suitable for the sprayhead use.

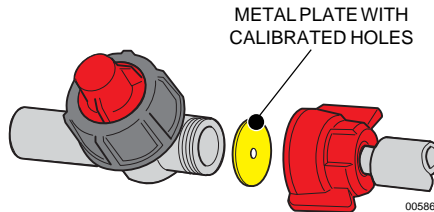

The diameter of the metal plate calibrated hole is indicated on the plate itself.

In the following table, the correspondences between the **position** of the rotary disc regulator and the **diameter** of the metal plate to be used for regulating the sprayer are reported.

CALIBRATED DISC POSITION	PLATE DIAMETER
2	1
3	1,2
4	1,5
5	-
6	1,8
7	2

TABSP1_001

DROP-STOPPING VALVES (4)

In order to avoid unwished droppings of mixture, when the sprayer is stopped and the mixture contained inside the tubes would tend, for gravity, to reach the lowest parts of the hydraulic circuit, on the heads are mounted specially purposed valves, which impede the reflux of the liquid by absence of pressure inside the circuit itself.

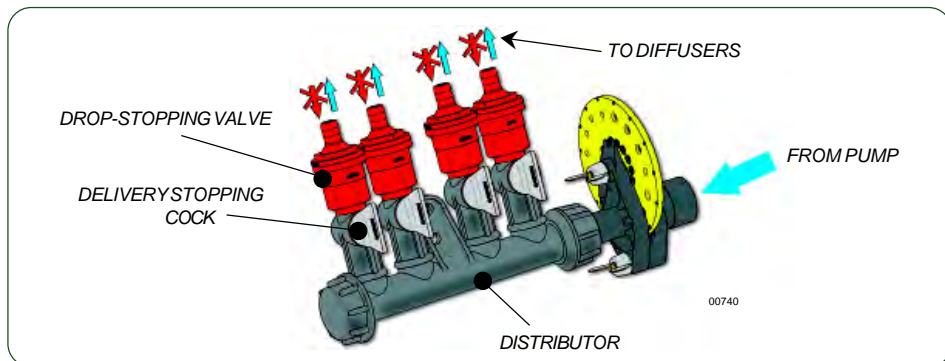

Besides, on the greatest and complex sprayheads, are used valves of different types and materials, they are of the ball-type and of the diaphragm one, used according with the different features of the sprayhead on which they are mounted, and assure the complete absence of losses and droppings, in the full observance of the antipollution rules in force.

BALL VALVES

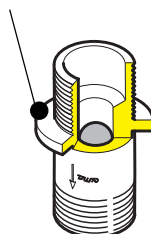

DIAPHRAGM VALVES

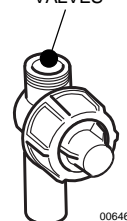

COUPLING COLLARS (6)

The coupling collars are the connecting device of the stiff tubes composing the sprayhead: connecting elbows, extensions, "Y" joints, etc. All the stiff tubes are equipped at their ends with a coupling lip, allowing to fix the collar and so assuring the perfect union and the required stiffness and etching between the different parts.

SPRAYERS CLASS

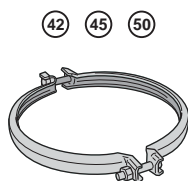

D = 175mm

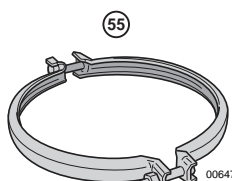

D = 250mm

(9) EXTENSIONS

In order to assure the necessary adjustments in height of the sprayheads, several extension tubes of different lengths are available (see Paragraph 4.2).

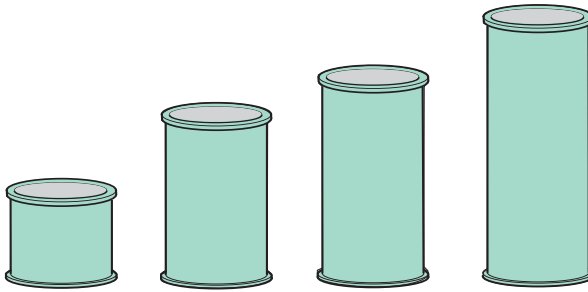

00746

HYDRAULIC CYLINDERS (2) and (11)

Double effect hydraulic cylinders were used to move the sprayheads. According to their different use, they can position the diffusers, they can regulate the sprayhead in high and width, they can withdraw the sprayhead. In TCF and TS5 sprayhead models, the hydraulic cylinders (3) have an adjustable eye (2) which enable to adjust the piston length to obtain the correct adjustment of the sprayhead closing angle.



The hydraulic cylinder adjustment is done during the mounting process and does not need any working's assistance.

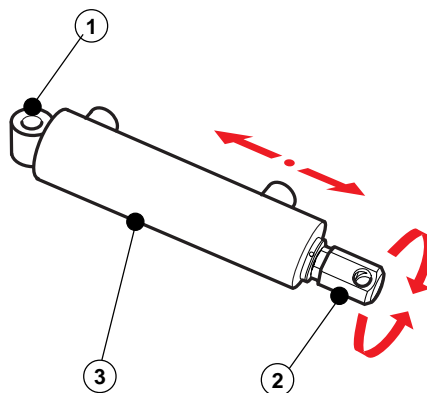

LEGENDA

1. FIXED EYE
2. HYDRAULIC CYLINDER SPRAYHEAD CLOSING
3. ADJUSTABLE EYE

4 MOUNTING FEATURES 4

4.1 - MOUNTING

All the types of sprayheads can be installed on the machines, either directly applied to the fan outlet mouth, or connected to the same one through connecting elbows or extension tubes, in order to obtain the most suitable position to the type of culture to be treated. The sprayers, according to their type or class, are supplied either complete with the connecting elbows or without them. In the same way, the sprayheads are supplied, if necessary, complete with the connecting elbow. In the example reported in the table, the same sprayhead can be mounted on different machines, provided that they belong to the same class.

<p>180° CONNECTING ELBOW</p> <p>00155</p>	<p style="text-align: center;">PLUS 50</p> <p>T.5+5.50.01</p> <p>00156</p>
<p>90° CONNECTING ELBOW</p> <p>00157</p>	<p style="text-align: center;">BLITZ 50</p> <p>UMDD007</p> <p>T.5+5.50.01</p>
<p>180° CONNECTING ELBOW</p> <p>00322</p>	<p style="text-align: center;">LINK 50</p> <p>T.5+5.50.01</p> <p>00342</p>

On the contrary, for other types of sprayheads (for example TC.2M.2C - 2 hands and 2 cannons), it isn't possible to realize the mounting on different sprayers, even not if they belong to the same class, as the head results to be specific for every series of sprayers: PLUS (P = Mounted sprayers), BLITZ (T = Trailer-mounted sprayers) and LINK (S = Joint-articulated sprayers).

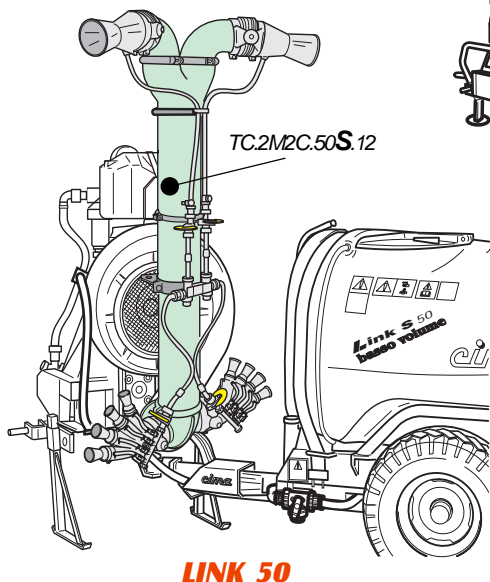
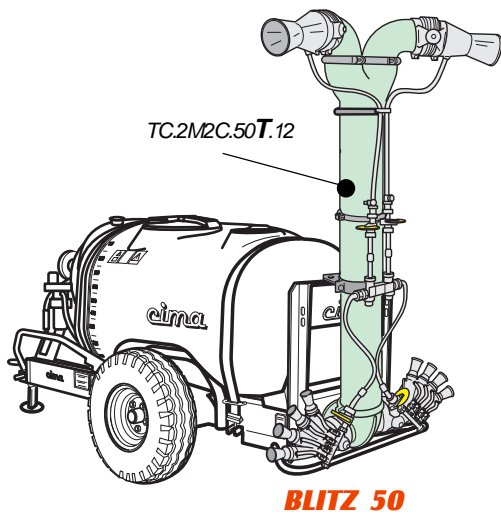
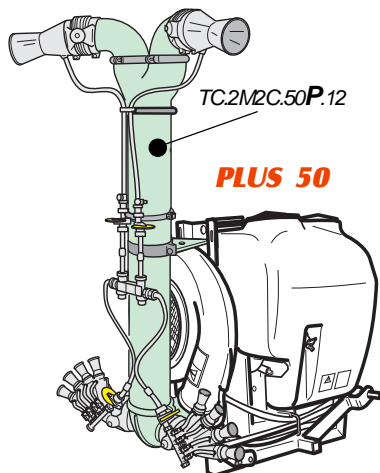

Besides, the same type of head can't be used on sprayers belonging to different classes, not even if of the same type; in that case, it is necessary to use the specific head for that sprayer class/type.

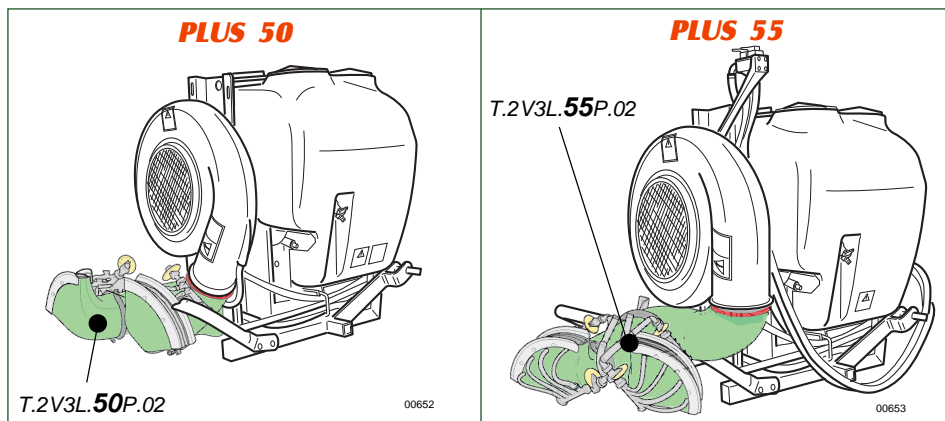

The fixing of the head to the fan outlet mouth (or to the outlet mouth of the fan connecting tunnel, in case of sprayers belonging to the BLITZ series) is realized by means of the fixing collar. In order to better explain how the head fixing is realized, the procedure is illustrated in the following figures; operate in the same way, in order to fix the connecting elbows or the extension tubes.

CONNECTION OF THE SPRAYHEAD TO THE FAN

- Remove the collar (4) from the outlet mouth (6) by unscrewing the nut (5) which locks it in position.
- Place the sprayhead coupling mouth (2) on the fan vertical mouth, by locking them by means of the collar which had been previously removed.



The mounted sprayhead must have the distributors with the rotary disc regulators positioned back and towards the sprayer outside.

- Connect the 2 feeding tubes (1) and (3) of the sprayer to the sprayhead rotary disc regulators.

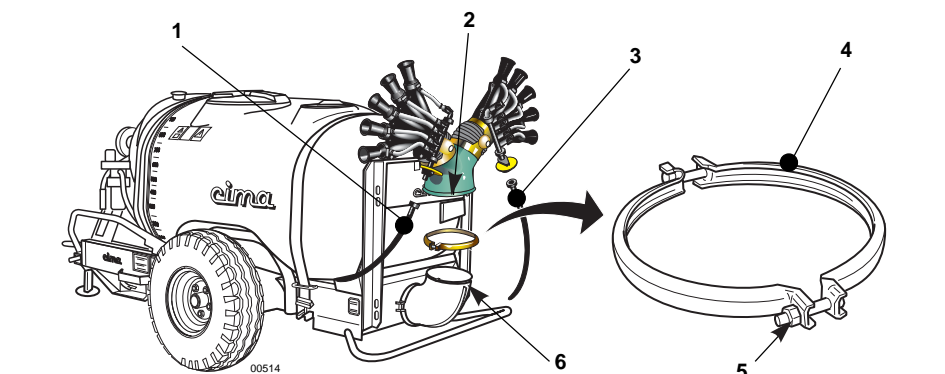

According with their dimension, their weight and their complexity, the sprayheads can be equipped with brackets, collars or, in the most complex cases, frames, for fixing the sprayhead to the sprayer. If necessary, the sprayhead is correlated with a mounting graphic card, enclosed to the "Spare parts' catalogue".

MOUNTING CARD

T.2M.2C
type TC.2M2C.50T.12

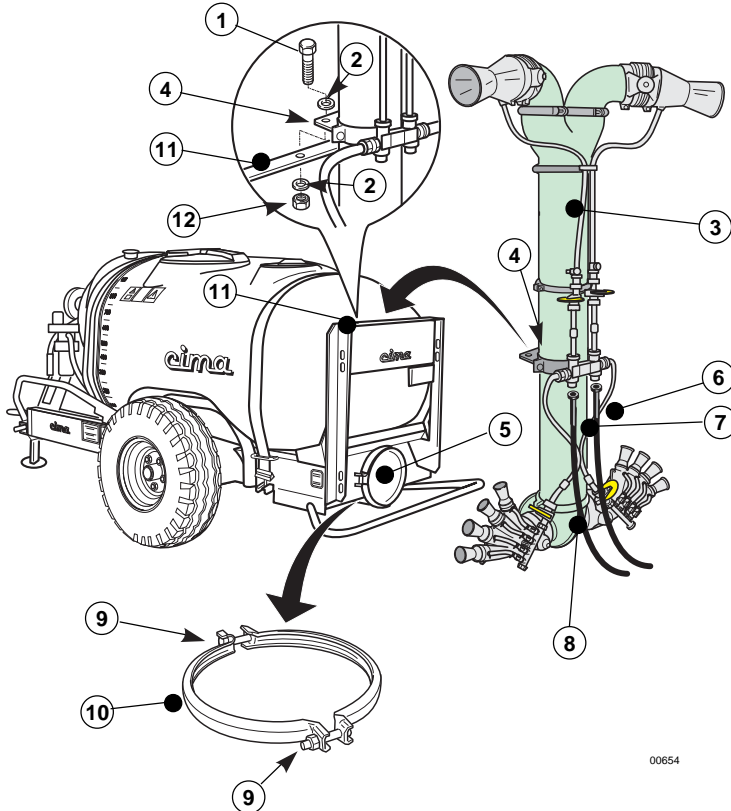

00654

Procedure:

1. Loosen the nuts (9) and remove the collar (10) from the outlet mouth (5) of the fan tunnel.
3. Position the sprayhead (3) and fix the bracket (4) to the sprayer frame (11) by means of the screws (1) with the relevant washers (2) and nuts (12).
3. Fix the connecting elbow (8) of the sprayhead to the outlet mouth (5) of the fan tunnel, locking it by means of the collar (10) which had been previously removed.
4. Connect the two sprayer tubes (6) and (7) with the sprayhead rotary disc regulators' union tees.

4.1.1.- Electrical connection

If the distribution device has electric actuator for the movement, their control is in the gearbox (E10). For the connection, please follow the sprayer manual user.

4.1.2 - Hydraulic input connection for the sprayhead movement

To connect the hydraulic cylinders moving the sprayhead they use pipes and rapid joints to connect directly to the hydraulic plant of the tractor.



The hydraulic pipes have to be connected according to the connection schema forseen for the accessories use (see the manual user of the used tractor).



1. Stop the tractor, remove the key from the control panel.



Before doing any pipes connection / moving acts, please be sure that the circuit **IS NOT** in pressure (see the manual "Instruction for use and maintenance" of the used tractor).

A oil leakage when the machine is in pressure can cause serious damages. Avoid any contact with eyes, mounth and skin: **ALWAYS** use personal protection devices: fans, eyewears, gloves, etc. Put in the closing area a proper basin to gather possible hydraulic oil leaks. Limit possible discharge with sand or different absorbing material proper to soak up all the oil: to dispose it, please follow the user country rules.

2. Remove the protection cap from the flexible pipe and from the distributor socket on the tractor.
3. Connect the pipes to flexible fittings until the complete connection.



After the hydraulic connection to the tractor, check it.



After completing the hydraulic connection to the sprayer check the hydraulic oil level (see the manual user of the used tractor).

4.2 - HEIGHT ADJUSTEMENT

It is possible to vary the mounting height of the distribution device by interposing between the same one and the standard elbow the especially purposed extensions available in different sizes. This type of adjustment can be realized on any type of sprayhead, according with the covering requirements of the culture structure to be treated.

Simple sprayheads

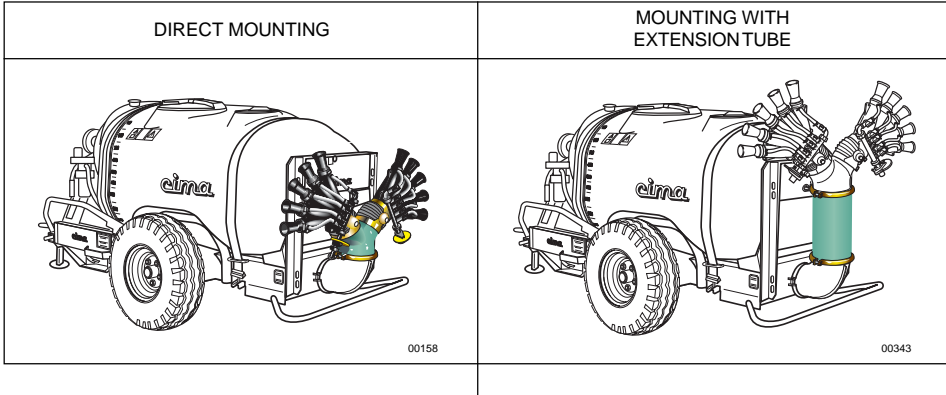

Combined sprayheads without supporting frame

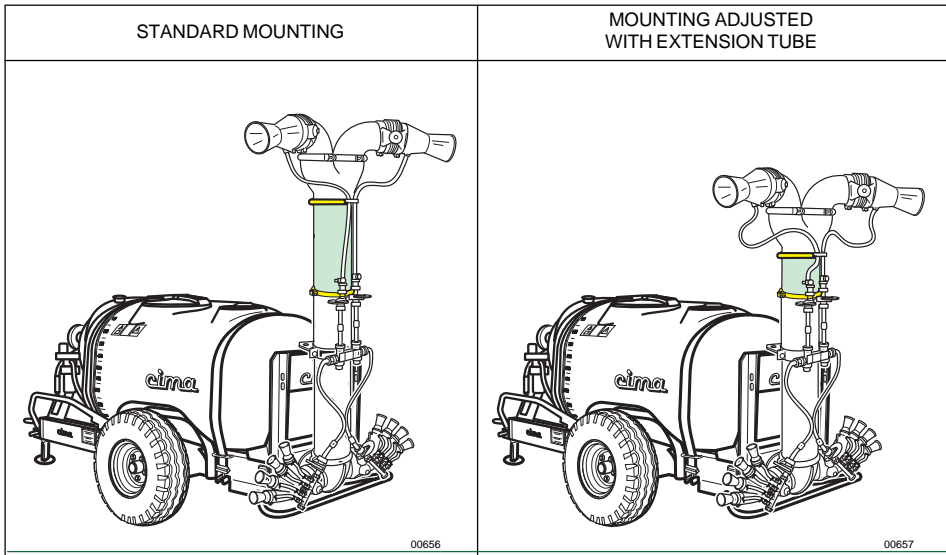

The following table reports the sizes and the weight of the available extensions for every type of machine.

Description	Model	Part/Number	Weight (kg)
D.175 x 200 mm Extension	All 42/45/50 models	X02.186.000	2,10
D.175 x 400 mm Extension	All 42/45/50 models	X02.187.000	3,45
D.175 x 600 mm Extension	All 42/45/50 models	X02.188.000	4,75
D.175 x 800 mm Extension	All 42/45/50 models	X02.189.000	6,25
D.250 x 200 mm Extension	All 55 models	X21.100.020	3,40
D.250 x 400 mm Extension	All 55 models	X21.100.040	5,30
D.250 x 600 mm Extension	All 55 models	X21.100.060	7,15
D.250 x 800 mm Extension	All 55 models	X21.100.080	9,00
Collars	For D.175mm. extensions and elbows	X05.616.000	0,40
	For D.250mm. extensions and elbows	X05.813.000	0,95

TABLE_013

Combined sprayheads with supporting frame

In the bigger sized sprayheads, the supporting frames are realized in such a way to allow an excursion of the diffusers both in height and in width.

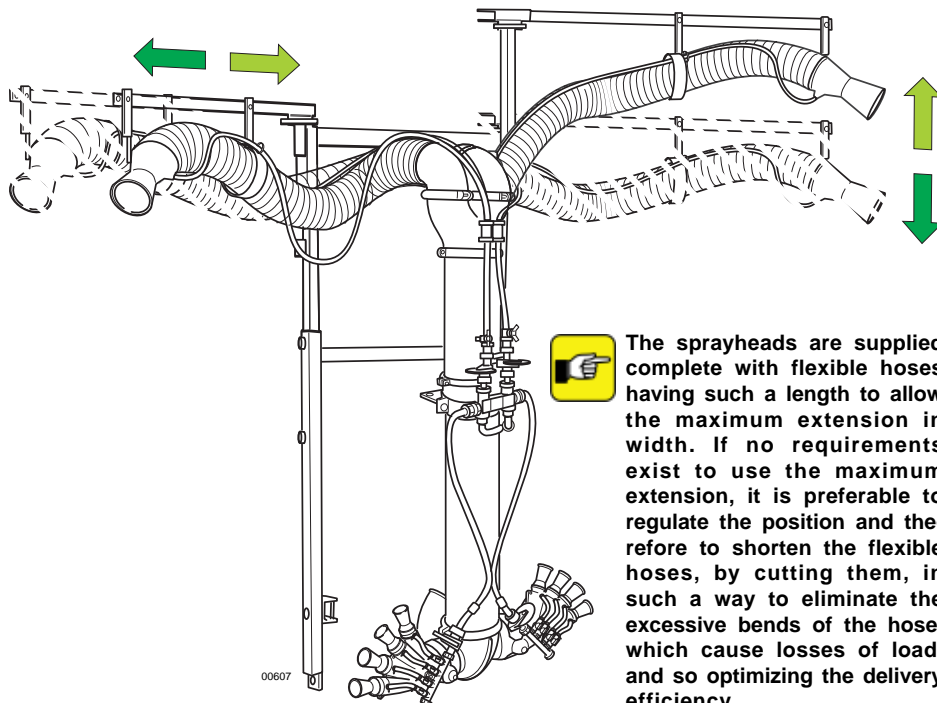

The guaranteed excursion in height by means of the simple frame adjustment is of approximately $20 \div 30$ cm; should it be necessary to reach a higher height, it is anyway possible to use the extension tubes, like for the other sprayheads.



Check the maximum extension in height admitted by the frame BEFORE mounting the extension tube.

According with the treatment covering requirements, the sprayheads' height can also be varied by using the extensions with diffusers (Body-2 diffusers' kit – 2 hands-2 diffusers' kit). This allows to increase the treatment vertical amplitude on the row inner sides, so optimizing the delivery, according with the culture to be treated.

**COMPLETE BODY KIT
2 HANDS WITH 2 NOZZLES EACH**



00174

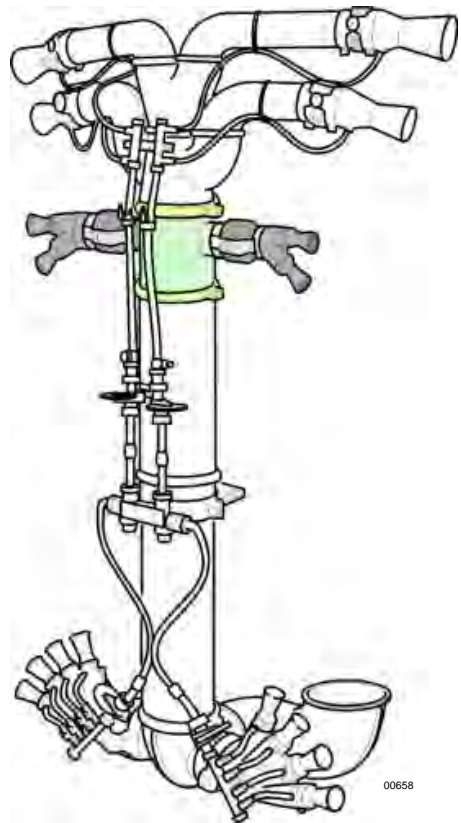

00658

Besides, it is possible to regulate the combined sprayheads' maximum width, by varying the orientation of the "Y" pipe fitting, connecting the main pipe with the diffusers. This solution can result to be especially useful when the rows are particularly narrow.

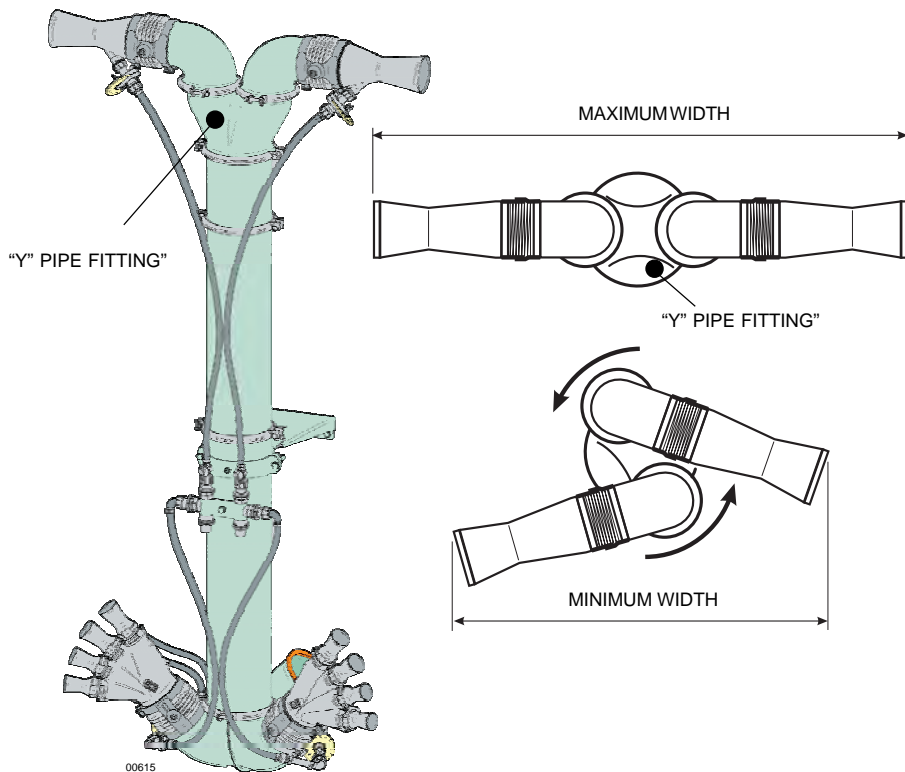

When, on the contrary, it would be necessary to increase the combined sprayheads' upper part width, in order to approach the upper diffusers to the external row, it is possible to use 90° extension elbows longer than the standard ones. The elbows are supplied in a single length version; anyway it is possible to shorten them by following the points foreseen for that operation, in order to reduce them to the wished length.

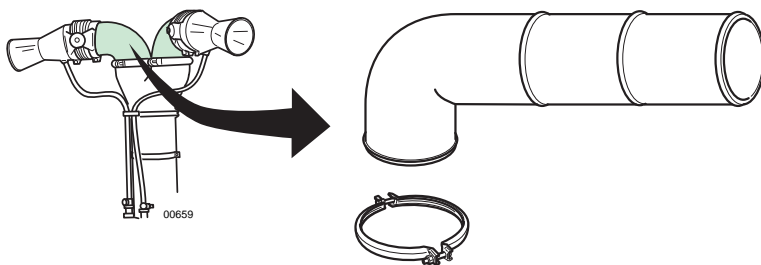

5 PROCEDURE FOR SPRAYHEAD USE 5

Before carrying out the treatment, the sprayhead has to be adjusted, in order to orient the sprayed jet on the target in the most efficacious way. The diffuser-carrier side bodies can be oriented both vertically, by rotating them upwards or downwards, and horizontally, by moving them backwards. It is sufficient to loosen the central nuts of the double joint clamps.

5.1 HANDS

VERTICAL ADJUSTMENT.

The air flow has to cover the whole surface to be treated, without missing the target.

- Vertically move the diffuser-carrier side bodies, in order to eliminate all mixture dispersion.

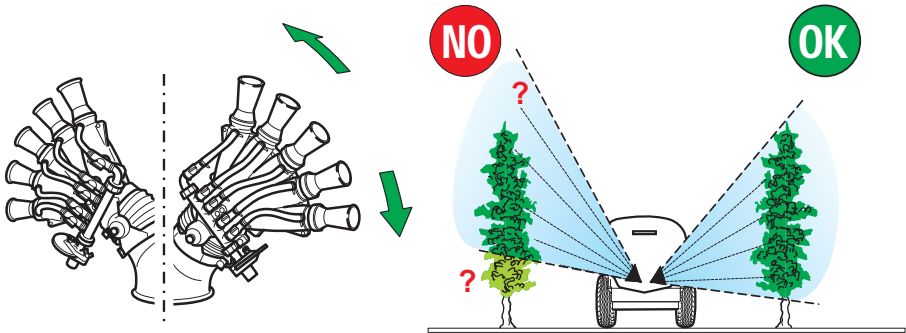

00608

- Eventually close the delivery of some diffusers and orient the sprayhead, if the covering angle would result to be too wide.

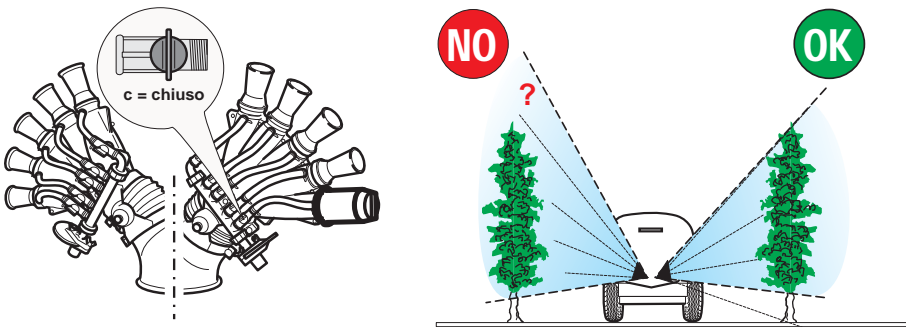

00609



To close a diffuser, in order to avoid all mixture dispersion during the treatment, has to be considered as a particular condition to adopt, for example during the first treatments of the season, when the vegetal covering doesn't still reach its 100% potentiality.

If, on the contrary, the situation requires to constantly operate with one or more closed diffusers, it is better to replace the sprayhead in use with another model, having less diffusers, like for example a **4+4 SPRAYHEAD** instead than a **5+5 SPRAYHEAD**.



To operate with one or more closed nozzles reduces the mixture penetration into the vegetation, what consequently results in a treatment lower efficacy.

- If necessary, rotate the nut (1) fastening the double joint clamp and rotate the diffuser-carrier side body by inclining it. By doing that, the vertical covering angle gets reduced, and in the same time, the "stripes" effect of the row covering gets reduced.

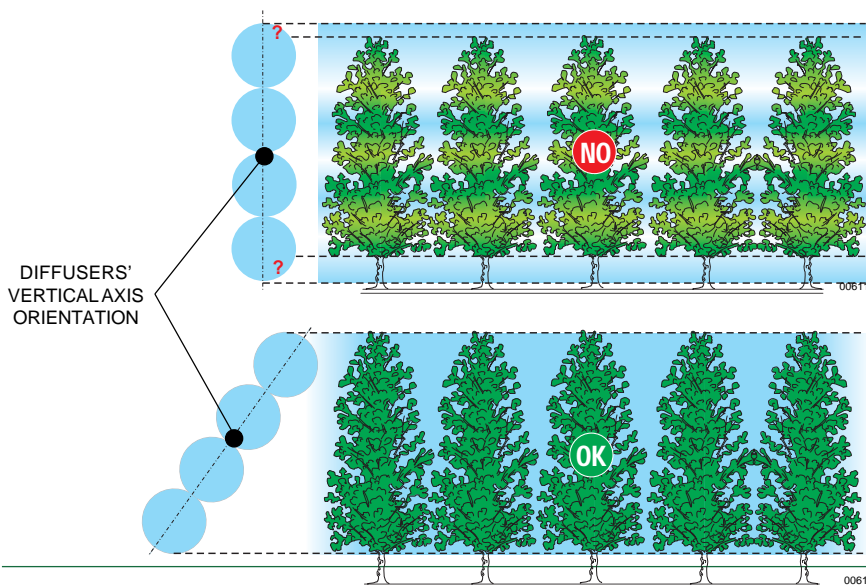
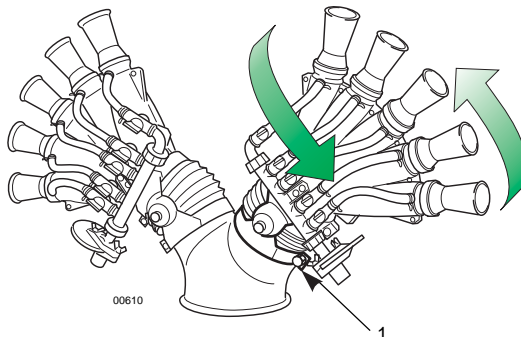

HORIZONTAL ADJUSTMENT.

The air flow has to cover the whole surface to be treated, without missing the target.

In order to better penetrate into the foliage, the air flow has to obliquely hit the culture rows.

- Position lightly backwards the diffuser-carrier side bodies (hands), in order to avoid to perpendicularly hit the culture.



After having completed the sprayhead adjustment, carefully tighten the double joint clamps.

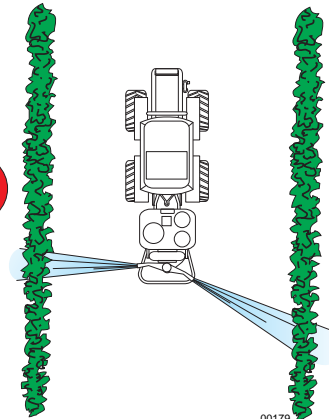

In order to get an optimal covering, especially on rows being less distanced than 2 meters, the best solution is to combine the horizontal adjustment with the diffusers' vertical axis orientation.

5.2 CANNONS JET

VERTICAL ADJUSTMENT.

The air flow has to cover the whole surface to be treated, without missing the target.

- Vertically move the cannon diffusers, in order to eliminate all mixture dispersion; adjust the sprayhead in height, by using, if necessary, some extension tubes having a suitable length.

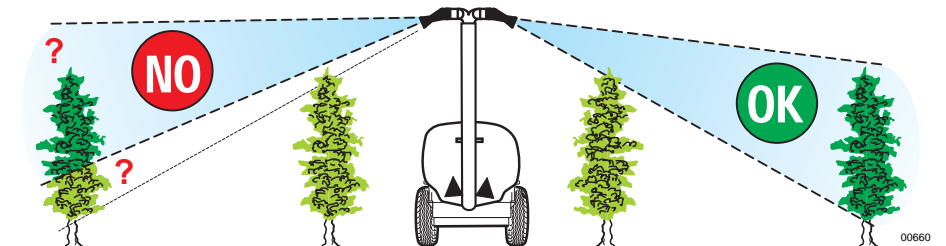
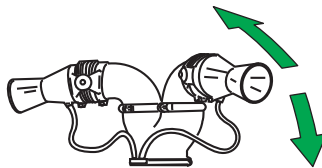

HORIZONTAL ADJUSTMENT.

The air flow has to cover the whole surface to be treated, without missing the target.
 In order to better penetrate into the foliage, the air flow has to obliquely hit the culture rows.

- Position lightly backwards the diffuser-carrier side bodies (cannons), in order to avoid to perpendicularly hit the culture.



After having completed the sprayhead adjustment, carefully tighten the double joint clamps

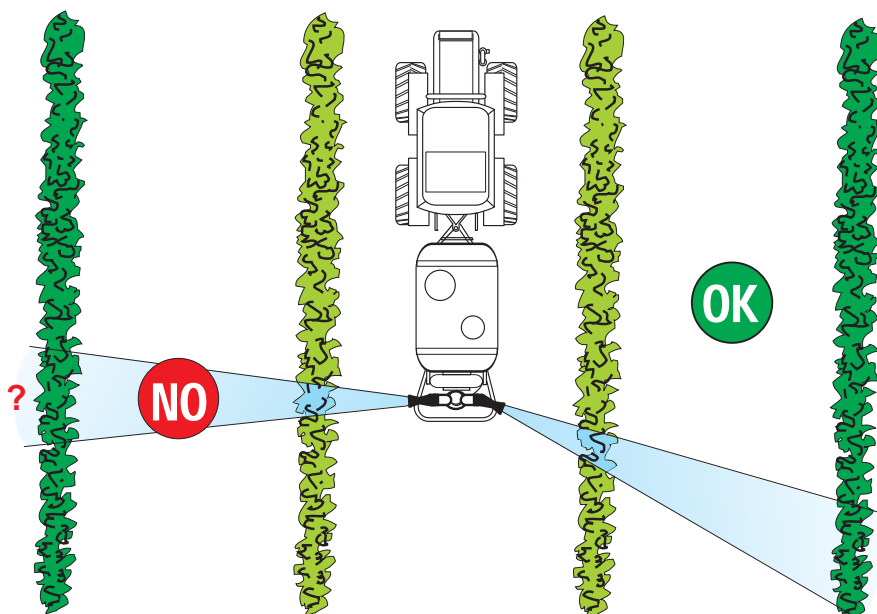
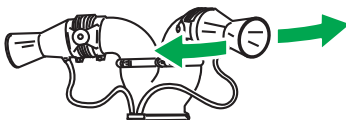

00661



The distribution heads provided with big cannons nebulizing the product to notable distance, over the 20/40 meters (to full field, on trees to tall stem or on crops inside which it is not possible to enter with the sprayer) they don't allow to check the exact distribution along the whole treated area. The wind, the turbulence of the flow of air, the obstacle furnished by the same vegetation by to treat, dissuades the use of cannons of big dimensions with chemical products that need a very precise distribution; **TO AVOID THE USE OF HERBICIDES OR SIMILAR PRODUCT.** To avoid besides to operate in proximity of urbanized areas or different crops from thet to treat for avoiding the risk of contamination.

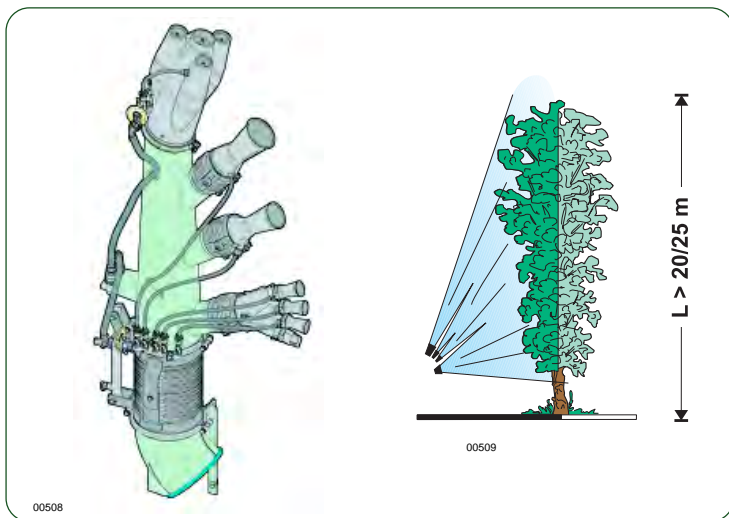
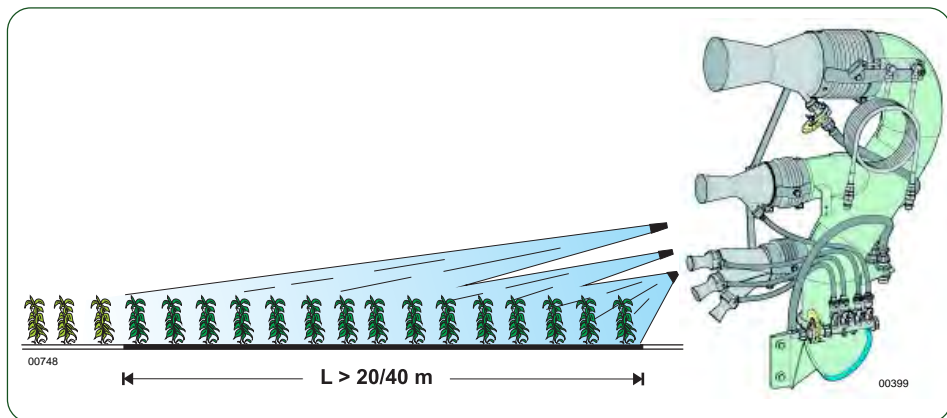

5.3 FISHTAILS

VERTICAL ADJUSTMENT.

The air flow has to cover the whole surface to be treated, without missing the target.

- Loosen the nut of the collar locking the fishtail to the sprayhead body.
- Vertically move the fishtail, in order to eliminate all mixture dispersion.
- When the adjustment is completed, tighten the nut of the fishtail locking collar.

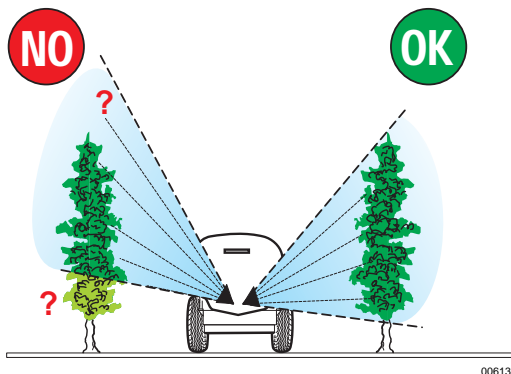
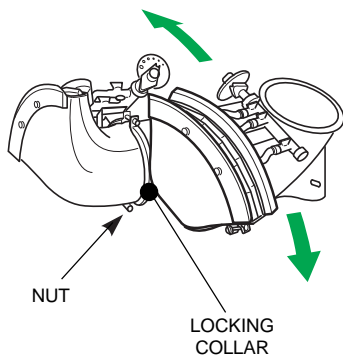

00613

- Eventually close the delivery for some fishtail sectors, if the covering angle would result to be too wide.

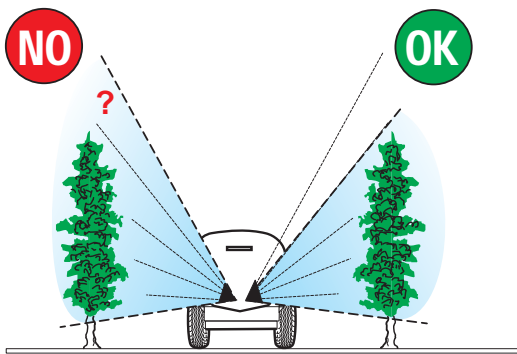
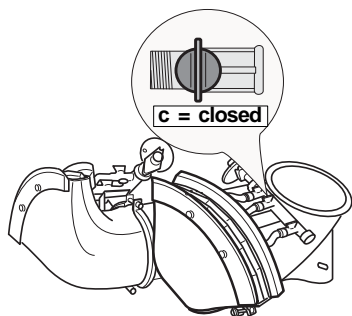

00614

5.4 - MANUAL SWIVELLING DEVICE



In order to apply that fitting, the sprayer has to be equipped with a **VERTICAL** outlet mouth.

This fitting is used in order to modify the spraying direction. It can be exclusively used with distribution devices realized for delivering the mixture on one side.

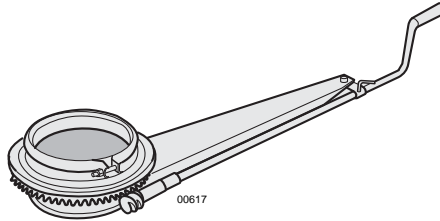

5.5 - ELECTRICAL SWIVELLING DEVICE



In order to apply that fitting, the sprayer has to be equipped with a **VERTICAL** outlet mouth.

This fitting is used in order to modify the spraying direction. It can be used as an alternative to the crank-operated revolving device, but exclusively with distribution devices realized for delivering the mixture on one side.

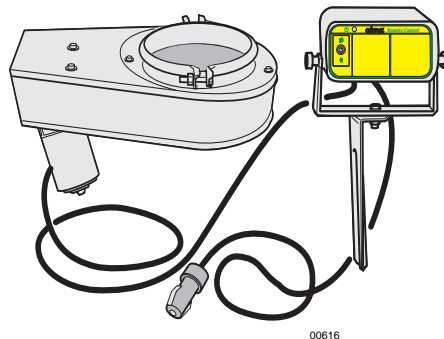

6 DELIVERIES' TABLE 6

Every distribution device is supplied with its specific deliveries' table. Through that table it is possible to determine the sprayer working pressure and the correspondent position of the rotary disc regulator, according with the required delivery expressed in liters/hour.



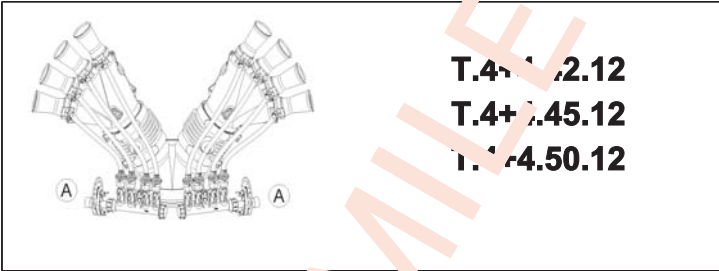





N° 2



1, Kg/cm²



1,5 Kg/cm²



2 Kg/cm²

A	A	l/h	l/h	l/h
1	1	80	100	110
2	2	100	120	135
3	3	140	160	180
4	4	190	210	230
5	5	250	260	280
6	6	285	310	340
7	7	375	400	440
8	8	460	495	550
9	9	560	610	665
10	10	630	695	790
11	11	760	850	970
12	12	980	1080	1220
13	13	1360	1480	1600
14	14	1620	1780	2180
15	15	1840	2100	2480

Info at www.cima.it or mail to: tecnic@cima.it 6E

01/26



**ALL OPERATIONS HAVE TO BE CARRIED OUT WITH THE TRACTOR MOTOR SWITCHED OFF AND WITH THE IGNITION KEY REMOVED FROM THE CONTROL PANEL.
NO SPECIFIC TYPE OF MAINTENANCE OPERATIONS IS FORESEEN.**

After every treatment, clean the hydraulic circuit, as indicated on the sprayer "Operation and Maintenance Instructions" manual. Use clean water in order to wash the tank inside, then let the sprayer operate, by spraying the liquid according with the law directives in force in the country where the unit is used: if necessary, repeat the operation.

The execution of that easy procedure allows to eliminate all mixture residuals from all the hydraulic circuits components, especially assuring the cleanness and the consequent efficiency of the calibrated holes of the rotary disc regulators and of the metal pins of the regulators directly mounted on the sprayhead feeding tube drop-stopping valve.



On the machines equipped with unit-washing tank, every time that it is necessary to interrupt the treatment, it is possible to wash the hydraulic circuit, independently on the tank loading conditions, i.e., also when the tank is still containing some mixture, what allows to avoid any clogging and assures the perfect efficiency of the machine when the treatment is carried on.

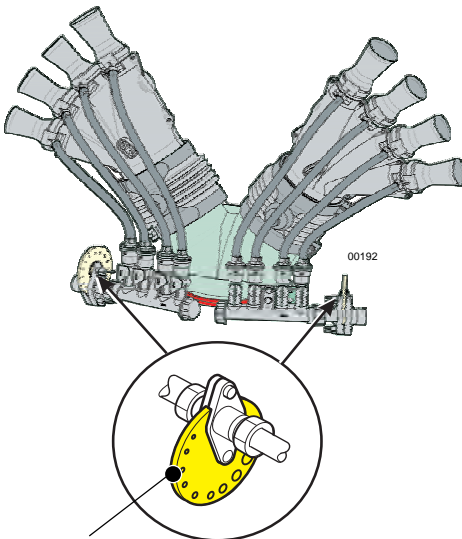

CALIBRATION DISC

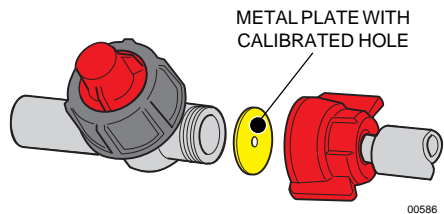

A. FAULT: SPRAYING ACTION IS MISSING only on one sprayhead side.

- 1st CAUSE The hole of the rotary disc regulator or of the metal pin is clogged.
REMEDY: *clean the clogged hole.*



Use exclusively water in order to clean the hole. DON'T USE EITHER SHARP OR METAL TOOLS.

- 2nd CAUSE Cocks are closed.

REMEDY: *open the cocks.*

- 3rd CAUSE The distributor is clogged by chemical products' residuals.

REMEDY: *clean the distributor.*

- 4th CAUSE The sprayer hydraulic circuit is defective.

REMEDY: *consult the sprayer operation and maintenance instruction manual.*

B. FAULT: SPRAYING ACTION IS MISSING from one diffuser only.

- 1st CAUSE Cock is closed.

REMEDY: *open the cock.*

- 2nd CAUSE Cock is clogged.

REMEDY: *clean the clogged cock.*

- 3rd CAUSE The rubber tube connecting the cock and the pipe union with fast coupling olive stopper is clogged.

REMEDY: *clean the clogged rubber tube.*

- 4th CAUSE The plastic tube with fast coupling olive stopper is clogged.

REMEDY: *clean the clogged plastic tube.*

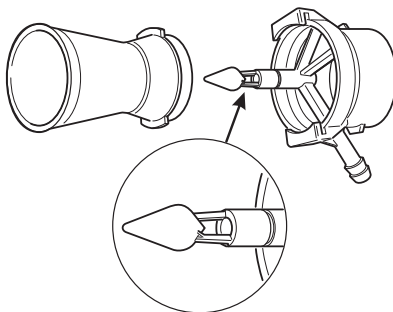

00193

C. FAULT: INTERMITTENT SPRAYING DELIVERY only on one sprayhead side.

- 1st CAUSE Missed sealing of the hydraulic circuit connecting the rotary disc regulator with the distributor.

REMEDY: *check the correct tightening of the rotary disc regulator throttle screws, check the proper operation of the regulator "O-ring" seal, check the clamps, the sealing of the pipe fittings and the integrity of the pipes and seals.*

Restore the full efficiency of the components and replace the parts which were possibly found defective.

2nd CAUSE Missed sealing of the distributor cap.

REMEDY: *tighten the distributor cap.*

3rd CAUSE Missed sealing of the sprayer hydraulic circuit.

REMEDY: *consult the sprayer operation and maintenance instruction manual.*

**D. FAULT: INTERMITTENT SPRAYING DELIVERY
from one diffuser only.**

1st CAUSE Slight cracking of cock-carrier fitting feeding the diffuser concerned.

REMEDY: *replace the distributor.*

2nd CAUSE Slight cracking of the cock feeding the diffuser concerned.

REMEDY: *replace the cock.*

3rd CAUSE Breakage of the cock "O-ring" inner seals.

REMEDY: *replace the cock.*

4th CAUSE Breakage of the cock "O-ring" seal.

5th CAUSE Plastic tube with fast coupling olive stopper is either clogged or cracked.

REMEDY: *clean or replace the fast coupling fitting.*

6th CAUSE Missed sealing of the feeling tube connecting the distributor with the diffuser.

REMEDY: *check the efficacy of the clamp.*

7th CAUSE Slight cracking of the diffuser rubber feeding tube.

REMEDY: *replace the tube.*

E. FAULT: MISSING MOVEMENT OF THE HYDRAULIC HEAD

1st CAUSE Missed sealing of the control hydraulic cylinders' connecting pipes.

REMEDY: *check the tightening and the good condition of the sealing clamps, replacing them if necessary.*

2nd CAUSE The control hydraulic cylinders' connecting pipes are either disconnected or broken.

REMEDY: *restore the pipes connection or replace the broken pipes.*

3rd CAUSE The control hydraulic cylinders are damaged.

REMEDY: *replace the damaged hydraulic cylinders.*

4th CAUSE The tractor power hydraulic circuit is inefficient.

REMEDY: *consult the "Operation and maintenance instruction" manual of the tractor.*



THE OWNER AND/OR THE OPERATOR OF THE SPRAYER ARE NOT PERMITTED TO MODIFY THE STRUCTURE OR THE SPECIFIC OPERATION OF THE SPRAYER ITSELF. ANY REPAIRING INTERVENTION HAS TO BE CARRIED OUT EITHER AT THE DEALERS' OR AT THE C.I.M.A. S.p.A. AUTHORIZED WORKSHOPS, OTHERWISE ANY KIND OF WARRANTY IMMEDIATELY CEASES AND C.I.M.A. S.p.A. IS CLEARED OF ANY CONSEQUENT AND/OR IMPLIED RESPONSIBILITY.

9.1 - Warranty

The goods sold are covered by a general warranty that ensures the good quality of the materials, solid construction and regular operation for twelve months from the date of delivery.

During the warranty period, C.I.M.A. S.p.A. pledges to replace, free of charge, the parts which, in his unquestionable judgement, are considered defective, provided that the flaws and defects cannot be attributed to poor use or maintenance of the product or an unreasonable, inappropriate and unsuitable use of such product with respect to the technical instructions supplied by C.I.M.A. S.p.A.

The products which have been modified, repaired, assembled or tampered with by a third party, consumption materials and the parts subject to wear and tear are excluded from the warranty.

The replacements will be made free CIMA S.p.A. works and the buyer will be responsible for all shipping and return expenses.

The buyer will be responsible for the costs of the labour needed to replace the parts considered defective. The resolution of the contract and any compensation for damage cannot be claimed by the buyer except for serious faults to be proven by said buyer.

The warranty will no longer be extended to the buyer if he does not respect the agreed upon payment procedures and terms.

9.2 - Reporting defects in goods

The claims for flaws or defects in the goods shall be submitted within eight days from when such goods are received or from when hidden defects are discovered, in writing, by means of a registered letter. No claim can be made, nor as an exception, in a court of law if the goods, for which the claim is submitted, have not been regularly paid.

Any claim concerning a single delivery of goods will not exonerate the buyer from his obligation to pick-up the remaining quantity of goods within the limit of the order.

9.3 - To pass safety information

The buyer is responsible towards the final user for the safety information shown on the sale documentation, concerning use limit, performances and product features.

Where we are





cima[®] S.p.A.

27040 Montù Beccaria - Loc. Molino Quaroni - (PV) - ITALIA

Tel. +39.0385.246636 r.a. - Fax +39.0385.246637

<http://www.cima.it>