



**BLITZ**

## OPERATION AND MAINTENANCE INSTRUCTION

**cima**® S.p.A.

27040 Montù Beccaria - Loc. Molino Quaroni - (PV) - ITALIA  
Tel. +39.0385.246636 r.a. - Fax +39.0385.246637  
<http://www.cima.it>

**cima**®

**atomizzatori e impolveratori**

*Dear Customer, thank you very much!*

*We want to congratulate with you, for having chosen a **cima**® sprayer.*

*Your choice shows the wisdom of the well-informed Purchaser, aware of the fact, that the required features of quality, technique and reliability must be satisfied at the right price!*

*Our continuous engagement in R&D and in testing our machines allows us to realize products able to offer the best performances, a high reliability and a great easiness of use at the same time !*

*Our first goal, is to get our Customers happy for having met us!*

The "Spare parts catalogue" of this sprayer/sprayhead is available in the "restricted area" on website [www.cima.it](http://www.cima.it).

In order to accede, use:

Username: **sprayer**  
Password: **844719KE**

Where we are



**Warranty conditions**

**1. Warranty**

The goods sold are covered by a general warranty that ensures the good quality of the materials, solid construction and regular operation for twelve months from the date of delivery. During the warranty period, C.I.M.A. S.p.A. pledges to replace, free of charge, the parts which, in his unquestionable judgement, are considered defective, provided that the flaws and defects cannot be attributed to poor use or maintenance of the product or an unreasonable, inappropriate and unsuitable use of such product with respect to the technical instructions supplied by C.I.M.A. S.p.A. The products which have been modified, repaired, assembled or tampered with by a third party, consumption materials and the parts subject to wear and tear are excluded from the warranty. The replacements will be made free CIMA S.p.A. works and the buyer will be responsible for all shipping and return expenses. The buyer will be responsible for the costs of the labour needed to replace the parts considered defective. The resolution of the contract and any compensation for damage cannot be claimed by the buyer except for serious faults to be proven by said buyer. The warranty will no longer be extended to the buyer if he does not respect the agreed upon payment procedures and terms.

**2. Reporting defects in goods**

The claims for flaws or defects in the goods shall be submitted within eight days from when such goods are received or from when hidden defects are discovered, in writing, by means of a registered letter. No claim can be made, nor as an exception, in a court of law if the goods, for which the claim is submitted, have not been regularly paid. Any claim concerning a single delivery of goods will not exonerate the buyer from his obligation to pick-up the remaining quantity of goods within the limit of the order.

**3. To pass safety information**

The buyer is responsible towards the final user for the safety information shown on the sale documentation, concerning use limit, performances and product features.

**4. Validity and acceptance**

The guarantee is valid if the CERTIFICATE OF GUARANTEE is sent, to C.I.M.A. S.p.A., with every part of it filled in, within 30 days from the date of purchase (referring to the date of the postmark).

**Informative according to the D. L. n. 196 of the 2003 ("Code in matter of protection of the personal data")**

Dear customer, according to art. 13 of the D.Lgs. 196/03 "Unique Text on Privacy" (referred to as 'Law' here below) we would like to inform you about the following:

- 1) the personal data given to C.I.M.A. S.p.A. when filling in the "Warranty Certificate" will be processed respecting the above mentioned regulations and the rules of privacy stated there in;
- 2) according to art.4, paragraph 1, lett. a) of the Law, the handling of personal data signifies "whatever operation or set of operations carried out (even without the aid of electronic instruments) regarding the collection, recording, organization, conservation, research, handling, modification, selection, extracting of details, comparison of, use of, connecting to, blockage, passing on, distributing, cancellation and destruction of data, even if not recorded in a data bank";
- The handling of the personal data given is carried out by automatized and non automatized instruments, with controlled access and as specified by clause B of the Law;
- 3) the data are processed to an institutional end, in connection with or useful to the activities of C.I.M.A. S.p.A. for filing, processing and management;
- 4) the data are collected and recorded so that access is only allowed to authorized persons and they may be processed exclusively by C.I.M.A. S.p.A. to the above mentioned end;
- 5) the collected data may only be given to a third party exclusively in connection with accounting imposed by fiscal law and in the case of demands from the judicial authority.

In addition we inform you that any interested party may exercise his rights mentioned in art.7 of the Law; in the exercise of such rights the interested party may delegate or give a proxy, in writing, to persons or associations. The authority to carry out this processing is C.I.M.A. S.p.A., represented in person by a lawyer.

The data processing is done by instruments fit to guarantee the safety and privacy as specified in clause B of the Law.

**Low volume sprayers  
trailed models  
Blitz**

Model: .....

Serial Number: .....

(Publication N° LUM-BLITZ-08)

**OPERATION AND  
MAINTENANCE INSTRUCTIONS**

©CIMA S.P.A. 1996 - 2012 Private property.  
Any reproduction, even if partial, is forbidden if not preventively authorized in writing by the Cima S.p.A. company.



CIMA S.p.A. - 27040 Montù Beccaria - Loc. Molino Quaroni - (PV) - ITALIA  
Tel. +39.0385.246636 r.a. - Fax +39.0385.246637  
<http://www.cima.it>



## WARRANTY CERTIFICATE

This warranty is valid only when this registration form is completed and returned, within thirty (30) days from the date of purchase, to the following address :

C.I.M.A. S.p.A. - Loc.Molino Quaroni - 27040 Montù Beccaria - (PV) - Italy  
or sent by fax to the number +39.0385.246637 or by email to: info@cima.it

Owner's Name: .....

Company Name: .....

Address: .....

City: ..... State: ..... Postcode: .....

Email: ..... Tel. No: .....

Date of Purchase: ..... Invoice No: .....

Machine Model: ..... Serial No: .....

Sprayhead Model: .....

Authorized Dealer's Stamp (compulsory)

## PRIVACY

### Consent to the use of personal data

"In compliance with the Italian legislative Decree no. 196 dated 30/06/2003, I hereby authorize C.I.M.A. S.p.A. to use and process my personal details contained in this document."

Date ..... Signature .....

cut along the dotted line

**Warranty conditions**

**1. Warranty**

The goods sold are covered by a general warranty that ensures the good quality of the materials, solid construction and regular operation for twelve months from the date of delivery. During the warranty period, C.I.M.A. S.p.A. pledges to replace, free of charge, the parts which, in his unquestionable judgement, are considered defective, provided that the flaws and defects cannot be attributed to poor use or maintenance of the product or an unreasonable, inappropriate and unsuitable use of such product with respect to the technical instructions supplied by C.I.M.A. S.p.A. The products which have been modified, repaired, assembled or tampered with by a third party, consumption materials and the parts subject to wear and tear are excluded from the warranty. The replacements will be made free CIMA S.p.A. works and the buyer will be responsible for all shipping and return expenses. The buyer will be responsible for the costs of the labour needed to replace the parts considered defective. The resolution of the contract and any compensation for damage cannot be claimed by the buyer except for serious faults to be proven by said buyer. The warranty will no longer be extended to the buyer if he does not respect the agreed upon payment procedures and terms.

**2. Reporting defects in goods**

The claims for flaws or defects in the goods shall be submitted within eight days from when such goods are received or from when hidden defects are discovered, in writing, by means of a registered letter. No claim can be made, nor as an exception, in a court of law if the goods, for which the claim is submitted, have not been regularly paid. Any claim concerning a single delivery of goods will not exonerate the buyer from his obligation to pick-up the remaining quantity of goods within the limit of the order.

**3. To pass safety information**

The buyer is responsible towards the final user for the safety information shown on the sale documentation, concerning use limit, performances and product features.

**4. Validity and acceptance**

The guarantee is valid if the CERTIFICATE OF GUARANTEE is sent, to C.I.M.A. S.p.A., with every part of it filled in, within 30 days from the date of purchase (referring to the date of the postmark).

**Informative according to the D. L. n. 196 of the 2003 (“Code in matter of protection of the personal data”)**

Dear customer, according to art. 13 of the D.Lgs. 196/03 “Unique Text on Privacy” (referred to as ‘Law’ here below) we would like to inform you about the following:

- 1) the personal data given to C.I.M.A. S.p.A. when filling in the “Warranty Certificate” will be processed respecting the above mentioned regulations and the rules of privacy stated there in;
- 2) according to art.4, paragraph 1, lett. a) of the Law, the handling of personal data signifies “whatever operation or set of operations carried out (even without the aid of electronic instruments) regarding the collection, recording, organization, conservation, research, handling, modification, selection, extracting of details, comparison of, use of, connecting to, blockage, passing on, distributing, cancellation and destruction of data, even if not recorded in a data bank”;
- The handling of the personal data given is carried out by automatized and non automatized instruments, with controlled access and as specified by clause B of the Law;
- 3) the data are processed to an institutional end, in connection with or useful to the activities of C.I.M.A. S.p.A. for filing, processing and management;
- 4) the data are collected and recorded so that access is only allowed to authorized persons and they may be processed exclusively by C.I.M.A. S.p.A. to the above mentioned end;
- 5) the collected data may only be given to a third party exclusively in connection with accounting imposed by fiscal law and in the case of demands from the judicial authority.

In addition we inform you that any interested party may exercise his rights mentioned in art.7 of the Law; in the exercise of such rights the interested party may delegate or give a proxy, in writing, to persons or associations. The authority to carry out this processing is C.I.M.A. S.p.A., represented in person by a lawyer.

The data processing is done by instruments fit to guarantee the safety and privacy as specified in clause B of the Law.

**LISTING OF VALID PAGES**

This publication consists of 99 pages, subdivided as follows:

N° OF PAGE	REVISION	BASE
from I to VI	08	April 2012
from 1 to 93	08	April 2012

**ADDITIONAL RECORDS AND VARIANTS**

REVISION	DESCRIPTION
00	First Edition, May 1996
01	Second Edition, November 2001
02	Third edition, January 2002
03	Fourth edition, June 2003
04	Fifth edition, October 2007
05	Sixth edition, April 2008
06	Seventh Edition, January 2009
07	Eighth Edition, April 2011
08	Revision, April 2012

## GENERAL INDEX

<b>1</b>	<b>FOREWORD</b> .....	1
1.1	CHECKS TO BE CARRIED OUT AT MATERIAL RECEPTION .....	1
1.2	PUBLICATION IDENTIFICATION .....	1
1.3	ATTACHED PUBLICATIONS .....	1
1.4	PURPOSE OF PUBLICATION .....	1
1.5	REFERENCE TO REGULATIONS .....	2
1.6	USING THE MANUAL .....	2
1.7	UPDATES .....	2
<b>2</b>	<b>GLOSSARY</b> .....	3
2.1	TERMINOLOGY .....	3
2.2	ABBREVIATIONS .....	3
2.3	DECALS .....	3
<b>3</b>	<b>GENERAL INFORMATION</b> .....	8
3.1	MACHINE IDENTIFICATION .....	8
3.2	TECHNICAL ASSISTANCE .....	8
3.3	SAFETY NOTICES .....	8
3.3.1	General .....	8
3.3.2	Precautions against the fires .....	9
3.4	SAFETY SYSTEMS .....	10
3.5	HANDLING OF AGRO-CHEMICALS .....	10
3.5.1	Storage .....	11
3.5.2	Specific equipment .....	11
3.5.3	Disposal of empty containers and agro-chemical residues .....	11
3.5.4	Personal means of protection .....	12
<b>4</b>	<b>MACHINE'S STRUCTURAL ANALYSIS</b> .....	13
4.1	FRAME WITH DRAWBAR .....	14
4.2	STEERING DRAWBAR .....	17
4.2.1	Drawbar for the towl hook .....	17
4.2.2	Drawbars for the 3-point connection .....	17
4.3	FAN SERVOAMPLIFIER .....	19
4.4	HYDRAULIC CIRCUIT COMPONENTS .....	20
4.5	TECHNICAL DATA .....	34
4.5.1	Sprayers dimensions and weights .....	34
4.5.2	Accessories weight .....	36
4.5.3	Centrifugal pump CD 32 .....	38
4.5.4	Filters .....	39
4.5.5	Tanks .....	39
4.5.6	Fans .....	39

## WARRANTY CERTIFICATE

Copy for the owner (to be kept in the manual "Operation and maintenance instructions").

Owner's Name: .....

Company Name: .....

Address: .....

City: ..... State: ..... Postcode: .....

Email: ..... Tel. No: .....

Date of Purchase: ..... Invoice No: .....

Machine Model: ..... Serial No: .....

Sprayhead Model: .....

Authorized Dealer's Stamp (compulsory)

## PRIVACY

### Consent to the use of personal data

"In compliance with the Italian legislative Decree no. 196 dated 30/06/2003, I hereby authorize C.I.M.A. S.p.A. to use and process my personal details contained in this document."

Date ..... Signature .....



<b>11</b>	<b>TANK AND HYDRAULIC CIRCUIT DRAINING</b> .....	66
<b>12</b>	<b>LIFTING AND TRANSPORT</b> .....	67
<b>13</b>	<b>MAINTENANCE OPERATIONS</b> .....	68
13.1	LUBRICATION .....	68
13.2	FAN SHAFT SUPPORT OIL LEVEL CHECK .....	69
13.3	FAN SHAFT SUPPORT OIL REPLACEMENT .....	70
13.4	CLEANING OF FILTER'S CARTRIDGE .....	70
13.5	CLEANING OF THE FAN .....	70
13.6	FAN BELT TENSIONER .....	71
13.7	PUMP BELT TENSIONER .....	72
13.8	MAIN TANK FASTENING BELT .....	72
13.9	TABLE OF MAINTENANCE OPERATIONS .....	73
<b>14</b>	<b>FAULTS FINDING</b> .....	74
<b>15</b>	<b>REPAIRS ALLOWED</b> .....	77
15.1	REPLACEMENT OF PUMP CONTROL BELT .....	77
15.2	REPLACEMENT OF ELECTRICAL PANEL'S FUSES .....	78
15.3	PRESSURE GAUGE REPLACEMENT .....	78
15.4	INSPECTION AND CLEANING PUMP FILTER .....	79
15.5	TANK LEVEL GAUGE CLEANING .....	80
15.6	CHECK HYDRAULIC DELIVERY .....	81
15.6.1	Check with flow meter .....	81
15.6.2	Check without flow meter .....	82
15.7	TANK REMOVAL OR REPLACEMENT .....	83
15.8	REPLACEMENT LAMPS REAR LIGHTS .....	84
<b>16</b>	<b>INTEGRATIVE DIAGRAMS</b> .....	85
16.1	HYDRO-PNEUMATIC DIAGRAM .....	85
16.2	WIRING DIAGRAM .....	89
<b>17</b>	<b>NOISE LEVEL</b> .....	91
<b>18</b>	<b>ATTACHMENT: DECLARATION OF CONFORMITY</b> .....	92
<b>19</b>	<b>WARRANTY</b> .....	93
19.1	WARRANTY .....	93
19.2	REPORTING DEFECTS IN GOODS .....	93
19.3	TO PASS SAFETY INFORMATION .....	93
19.4	VALIDITY AND ACCEPTANCE .....	93

Fitting for gauge functional test ..... (P7 - FILTER) ... page 27  
 Fitting for pump flow verification ..... (P26 - JOINT FOR FLOW METER) ... page 34

## 19 WARRANTY 19



**THE OWNER AND/OR THE OPERATOR OF THE SPRAYER ARE NOT PERMITTED TO MODIFY THE STRUCTURE OR THE SPECIFIC OPERATION OF THE SPRAYER ITSELF. ANY REPAIRING INTERVENTION HAS TO BE CARRIED OUT EITHER AT THE DEALERS' OR AT THE C.I.M.A. S.p.A. AUTHORIZED WORKSHOPS, OTHERWISE ANY KIND OF WARRANTY IMMEDIATELY CEASES AND C.I.M.A. S.p.A. IS CLEARED OF ANY CONSEQUENT AND/OR IMPLIED RESPONSIBILITY.**

### 19.1 - Warranty

The goods sold are covered by a general warranty that ensures the good quality of the materials, solid construction and regular operation for twelve months from the date of delivery.

During the warranty period, C.I.M.A. S.p.A. pledges to replace, free of charge, the parts which, in his unquestionable judgement, are considered defective, provided that the flaws and defects cannot be attributed to poor use or maintenance of the product or an unreasonable, inappropriate and unsuitable use of such product with respect to the technical instructions supplied by C.I.M.A. S.p.A.

The products which have been modified, repaired, assembled or tampered with by a third party, consumption materials and the parts subject to wear and tear are excluded from the warranty.

The replacements will be made free CIMA S.p.A. works and the buyer will be responsible for all shipping and return expenses.

The buyer will be responsible for the costs of the labour needed to replace the parts considered defective. The resolution of the contract and any compensation for damage cannot be claimed by the buyer except for serious faults to be proven by said buyer.

The warranty will no longer be extended to the buyer if he does not respect the agreed upon payment procedures and terms.

### 19.2 - Reporting defects in goods

The claims for flaws or defects in the goods shall be submitted within eight days from when such goods are received or from when hidden defects are discovered, in writing, by means of a registered letter. No claim can be made, nor as an exception, in a court of law if the goods, for which the claim is submitted, have not been regularly paid.

Any claim concerning a single delivery of goods will not exonerate the buyer from his obligation to pick-up the remaining quantity of goods within the limit of the order.

### 19.3 - To pass safety information

The buyer is responsible towards the final user for the safety information shown on the sale documentation, concerning use limit, performances and product features.

### 19.4 - Validity and acceptance

The guarantee is valid if the CERTIFICATE OF GUARANTEE is sent, to C.I.M.A. S.p.A., with every part of it filled in, within 30 days from the date of purchase (referring to the date of the postmark).



# 18 ATTACHMENT : DECLARATON OF CONFORMITY 18

**DICHIARAZIONE DI CONFORMITÀ**  
ai sensi della Direttiva 2006/42/CE come emendata dalla Direttiva 2009/127/CE e successive modificazioni

DECLARATION OF CONFORMITY as Directive 2006/42/CE as amended by the Directive 2009/127/CE and subsequent modifications	DECLARATION DE CONFORMITE selon la Directive 2006/42/CE comme modifié donnee la Directive 2009/127/CE et modifications ultérieures
ÜBEREINSTIMMUNGS-ERKLÄRUNG II. Direktiven 2006/42/CE wie abändert von den Direktiven 2009/127/CE und nachfolgenden Änderung	DECLARACION DE CONFORMIDAD con arreglo a la Directiva 2006/42/CE según la emenda por la Directiva 2009/127/CE y modificaciones siguientes

**CIMA S.p.A. - 27040 Montù Beccaria - Loc. Molino Guaroni - (PV) - ITALIA**  
http://www.cima.it - e-mail: info@cima.it - Tel. +39.0385.246636 r.a. - Fax +39.0385.246637

DICHIARA SOTTO LA PROPRIA RESPONSABILITÀ CHE LA MACCHINA:	HERE WITH DECLARES, UNDER THEIR PERSONAL RESPONSABILITY, THE FOLLOWING MACHINE:	DECLARONS SOUS SA PROPRIE RESPONSABILITÉ QUE LA MACHINE DÉCRIT CLAPRES:	BESTÄTIGT / ERZIMT UNDER IHRER / IHREREN PERSÖNLICHEN VERANTWORTUNG DAS DIE MASCHINE:	DECLARA BAJO DE LA PROPIA RESPONSABILIDAD QUE LA MAQUINA:
---	---	---	---	---

SERIE, TIPO - MODELLO - SERIE - TIPO  
MODEL, TYP - MODELLO - TIPO:

MATRICOLA / SERIAL - MATRÍCULA  
SERIAL / MATRÍCULA

È conforme ai Requisiti essenziali di Sicurezza e di Tutela della Salute di cui alla Direttiva: <b>2006/42/CE - 17/05/2006</b> <b>2009/127/CE - 21/10/2009</b> e successive modificazioni. Per la verifica della Conformità di cui alle direttive sopra menzionate, sono state consultate le seguenti Norme armonizzate: <b>EN 13857</b> <b>EN 349</b> <b>EN 4254-1 e EN 4254-6</b>	Conforma to the essential Safety regulations as well as the Health requirements as per European Economic Community Directives. <b>2006/42/CE - 17/05/2006</b> <b>2009/127/CE - 21/10/2009</b> and subsequent modifications. For the verification of conformity as per above mention directives the following Normes Harmonized have been consulted: <b>EN 13857</b> <b>EN 349</b> <b>EN 4254-1 e EN 4254-6</b>	Est conforme aux exigences de Sécurité et de Santé de la Directive: <b>2006/42/CE - 17/05/2006</b> <b>2009/127/CE - 21/10/2009</b> et modifications ultérieures. Pour vérifier la conformité aux directives susmentionnées, ont été prises en compte les Normes harmonisées suivantes: <b>EN 13857</b> <b>EN 349</b> <b>EN 4254-1 e EN 4254-6</b>	Stimmt mit den wesentlichen Requisiten der Sicherheitsvorschriften un der Gesundheitsvorsorge II. EWG Richtlinie Nr.: <b>2006/42/CE - 17/05/2006</b> <b>2009/127/CE - 21/10/2009</b> und nachfolgenden Änderungen überein. Für die Überprüfung dieser Übereinstimmungs-Erklärung II. obigen Direktiven sind folgende Normen konsultiert worden: <b>EN 13857</b> <b>EN 349</b> <b>EN 4254-1 e EN 4254-6</b>	Cumple con los requisitos esenciales de Seguridad y de Preservación de la Salud contenidos en las Directiva: <b>2006/42/CE - 17/05/2006</b> <b>2009/127/CE - 21/10/2009</b> y modificaciones siguientes. Para comprobar la conformidad a la que se refieren las Directivas anteriormente citadas, se han consultado las siguientes Normas Armonizadas: <b>EN 13857</b> <b>EN 349</b> <b>EN 4254-1 e EN 4254-6</b>
--	---	--	---	--

Responsabile del Fascicolo Tecnico - The Security and Technical File Official - Responsable Sécurité, Homologations et Dossier Technico - Der Technisch Dossier und Sicherheits-Beatmer - Responsable de la Seguridad y del Fascículo Técnico

Montù Beccaria (PV) - Italy  
Data, Date, Datum, Fecha: \_\_\_\_\_

Smeraldi Paolo

**Atomizzatori e Impolveratori**  
CIMA S.p.A. - 27040 Montù Beccaria  
Loc. Molino Guaroni - (PV) Italy

(\*) Provided ONLY for the internal European Union market (EU).

# 1 FOREWORD 1

## 1.1 - CHECKS TO BE CARRIED OUT AT MATERIAL RECEPTION

At reception of the machine, make sure that this one is complete and in good condition in every part. If any damaged parts are found out, timely inform about that the machine Distributor, or directly contact C.I.M.A. SpA.

Upon receipt of the machine, expressly verify the following conditions:

- that the machine is delivered assembled in all its parts, and that the equipment fully complies with the requested configuration (that procedure is necessary, because for overall dimensions' requirements the machine is often partially disassembled during the transport);
- that the connections are correctly mounted;
- that the cable clamps are correctly tightened, as well as all the fittings and connections;
- that all the protections are both present and firmly fastened;
- that the oil level inside the fan support is correct;
- that the fan, the fan protection casing or other parts of the machine ARE NOT damaged because of any bumps suffered during the transport.

## 1.2 - PUBLICATION IDENTIFICATION

The "OPERATION AND MAINTENANCE INSTRUCTIONS" manual is an integrative part of the sprayers. It is identified by a Publication No. located on the frontispiece, and through which the document can be identified, traced and/or subsequently referred to.

The information elements contained herein are updated as at the date of publication. C.I.M.A. S.p.A. reserves the right to modify its machines without notice, with the purpose of applying technical enhancements, and it declines all responsibility for possible omissions from the publication.

All rights are reserved. No parts of this book may be reproduced or utilized in any form or by any means, electronic or mechanical, including photocopying, recording, or by any information storage and retrieval system, without permission in writing by C.I.M.A. S.p.A.

## 1.3 - ATTACHED PUBLICATIONS

- Spare parts catalogue;
- Distribution devices, "Operation and maintenance instruction";
- Distribution devices, "Spare parts catalogue"
- "Low Volume - Instructions for sprayer adjustment".

## 1.4 - PURPOSE OF PUBLICATION

All indications contained in this manual are aimed at the user of the sprayer.

The duration of the machine and its operation, the operator's safety and the respect for the environment are dependent upon scrupulous observance of the stated norms.

Before making use of the sprayer, the user must read, understand and abide by all regulations listed in this manual.

## 1.5 - REFERENCE TO REGULATIONS

This manual was set out conforming to the regulations contained in following documents:

- Directive 2006/42/CE: Attachment 1 point 1.7.4;
- UNI 10653: Technical Documentation;
- UNI 10893: Technical Documentation.

## 1.6 - USING THE MANUAL

Read every part of this manual, paying attention to the **WARNING** and **DANGER** indications both on the text and on the machine or on components.

All operations suggested by the manual will have to be followed with the utmost care and only after having understood the negative consequences of improper usage.

The following “**symbols**” are used within the text in order to highlight and visually identify the importance of the various types of information:



Indicates important additional information.



Non observance can result in permanent damage to the sprayer.



Highlights possibly dangerous situations to people.

The manual, with relevant attachments and possible integrating issues, must be kept with the utmost care and must always be complete, integer and legible in every part. Should it be mislaid it is imperative to immediately request a duplicate from C.I.M.A. S.p.A. Should the decals originally applied on the machine be mislaid, damaged or become incomprehensible, they should be promptly replaced.

For every type of distribution device (Head) delivered with the sprayer, a specific user and maintenance manual is attached. All the head manuals must always accompany the one of the machine.



- The manual must always be kept for the sprayer's whole operational life.
- Any modification received must be permanently inserted in this publication.
- The manual must be ceded with the sprayer should this be sold.

## 1.7 - UPDATES

Possible updates that C.I.M.A. S.p.A. will provide the owner of the sprayer will be accompanied by instructions to insert in this publication.

Should the machine be sold, the owner must inform the new purchaser that he should notify C.I.M.A. S.p.A. of his address in order to receive possible future integrating issues and/or updates.

Sprayer model	Observed equivalent average level L qA - dB(A)
BLITZ 45T	92,0 ± 0,2
BLITZ 50T	93,0 ± 0,2
BLITZ 55T	95,4 ± 0,2
BLITZ 55TS	95,4 ± 0,2
BLITZ 55TE	95,4 ± 0,2

BLITZ009

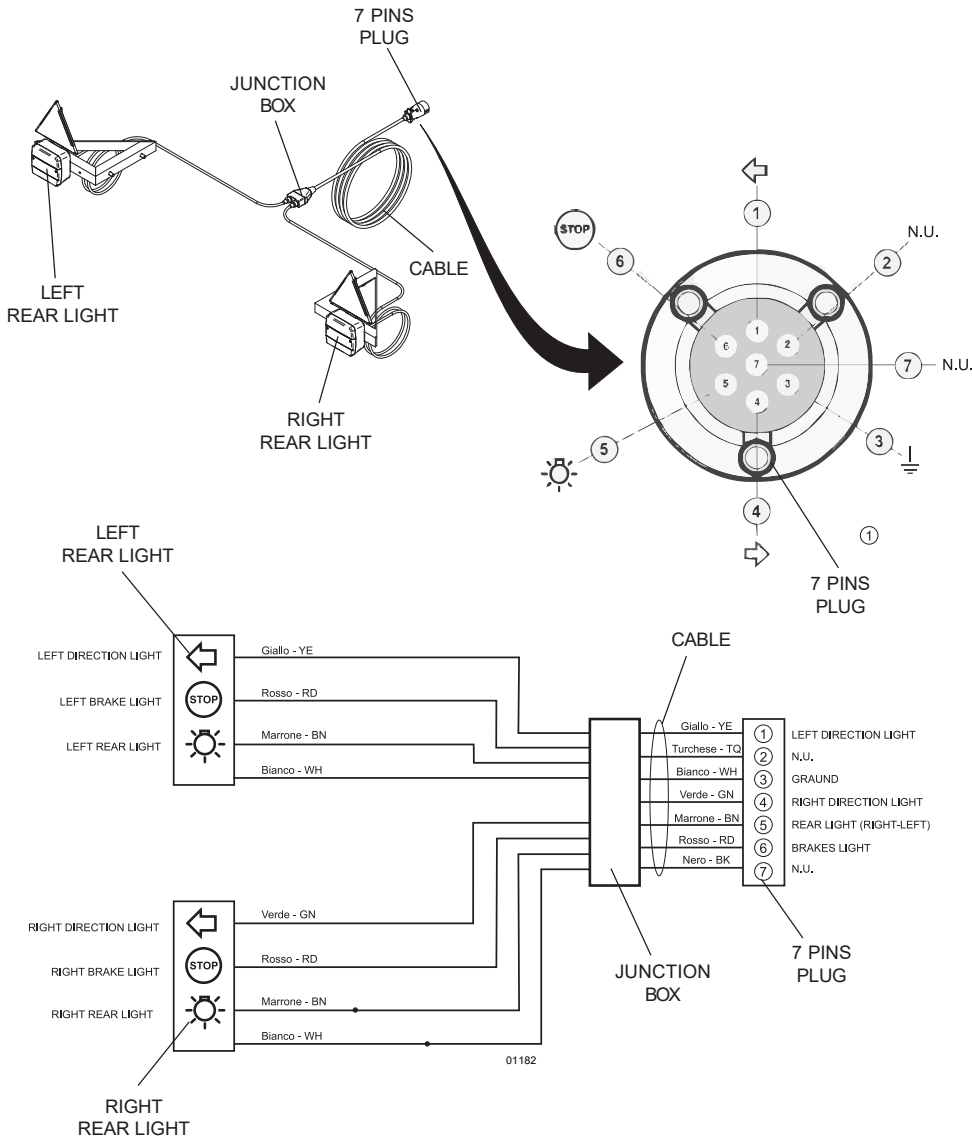

Wiring diagram for rear lights

2 GLOSSARY 2

2.1 - TERMINOLOGY

The terms FRONT, REAR, RIGHT and LEFT utilised in this publication refer to the sprayer as seen by an operator from behind the operative unit along the drive line and facing it: **the rear part** of the machine is that closest to the operator, and is where the distribution device (Head) is mounted - and **the front part** is the one that gets attached to the tractor.

2.2 - ABBREVIATIONS

cm	.....	centimeter
g	.....	grams
h	.....	hour
ha	.....	hectare
ha/h	.....	hectares per hour
l	.....	litre
l/h	.....	litres per hour
l/min.	.....	litres per minute
kg	.....	kilogram
kg/cm <sup>2</sup>	.....	kilograms per square centimetre (atmosphere)
km	.....	kilometre
km/h	.....	kilometres per hour
Lm	.....	width in metres
m	.....	metre
Mesh	.....	N° of meshes per liner inch
Micron	.....	1/1000 of millimetre
mm	.....	millimetre
PTO	.....	Power take-off
RPM	.....	revs per minute
s	.....	second

2.3 - DECALS

The safety and use/maintenance decals applied to the machine are described in the following paragraph.



Every decal is marked with its part number, in case it needs to be replaced.

The arrangement of the adhesives on the machine is shown in the following pictures.

Safety decals



95001

- STOP THE ENGINE AND REMOVE THE KEY FROM THE TRACTOR'S CONTROL PANEL BEFORE CARRYING OUT ALL MAINTENANCE OR REPAIR OPERATIONS
- CONSULT THE USER AND MAINTENANCE MANUAL BEFORE USING OR INTERVENING ON THE MACHINE



95098

- CONSULT THE USER AND MAINTENANCE MANUAL BEFORE USING THE MACHINE
- DANGER OF CONTAMINATION BY CONTACT OR POISONOUS PRODUCTS INHALATION
- IT IS FORBIDDEN TO ENTER INTO THE TANK!



95005

- DANGER, PARTS IN MOTION. BEFORE REMOVING PROTECTION GUARDS, STOP THE TRACTOR, REMOVE THE KEY FROM THE TRACTOR'S CONTROL PANEL AND ENSURE THAT ALL MOVING PARTS HAVE STOPPED



95007

- DANGER OF SPRAYS: KEEP AT A SAFE DISTANCE



95008

- NO HAND-WASHING TANK



95010

- MAXIMUM OPERATING SPEED OF THE DRIVE OUTLET (PTO): 540 RPM



95009

- DANGER: GLOVES MUST BE USED TO EMPTY THE TANK



95015

- BEFORE UTILISING THE RELEASE DEVICE, STOP THE TRACTOR, REMOVE THE KEY FROM THE TRACTOR'S CONTROL PANEL AND ENSURE THAT THE FAN HAS STOPPED

16.2 - WIRING DIAGRAM

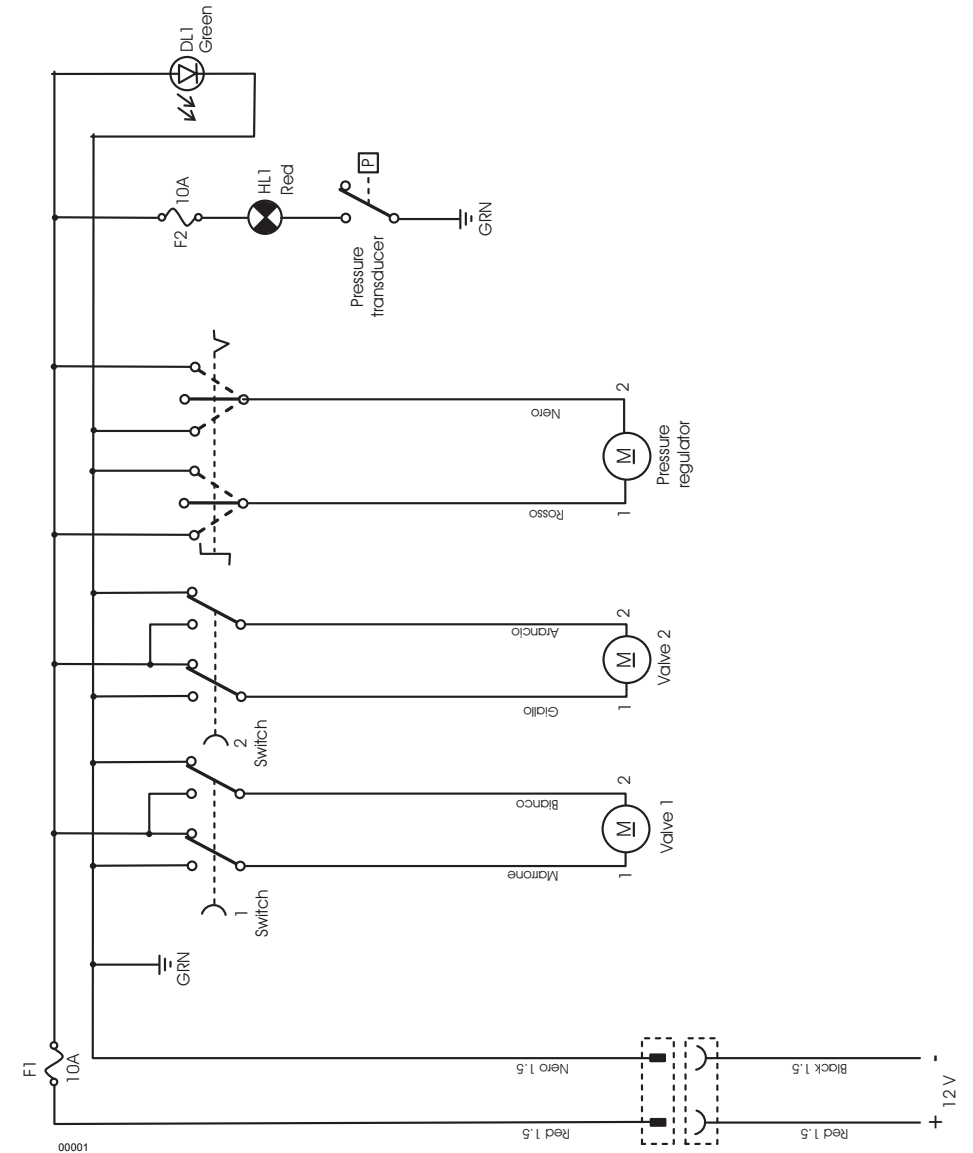

E.P.A. versions with additional agitation pump

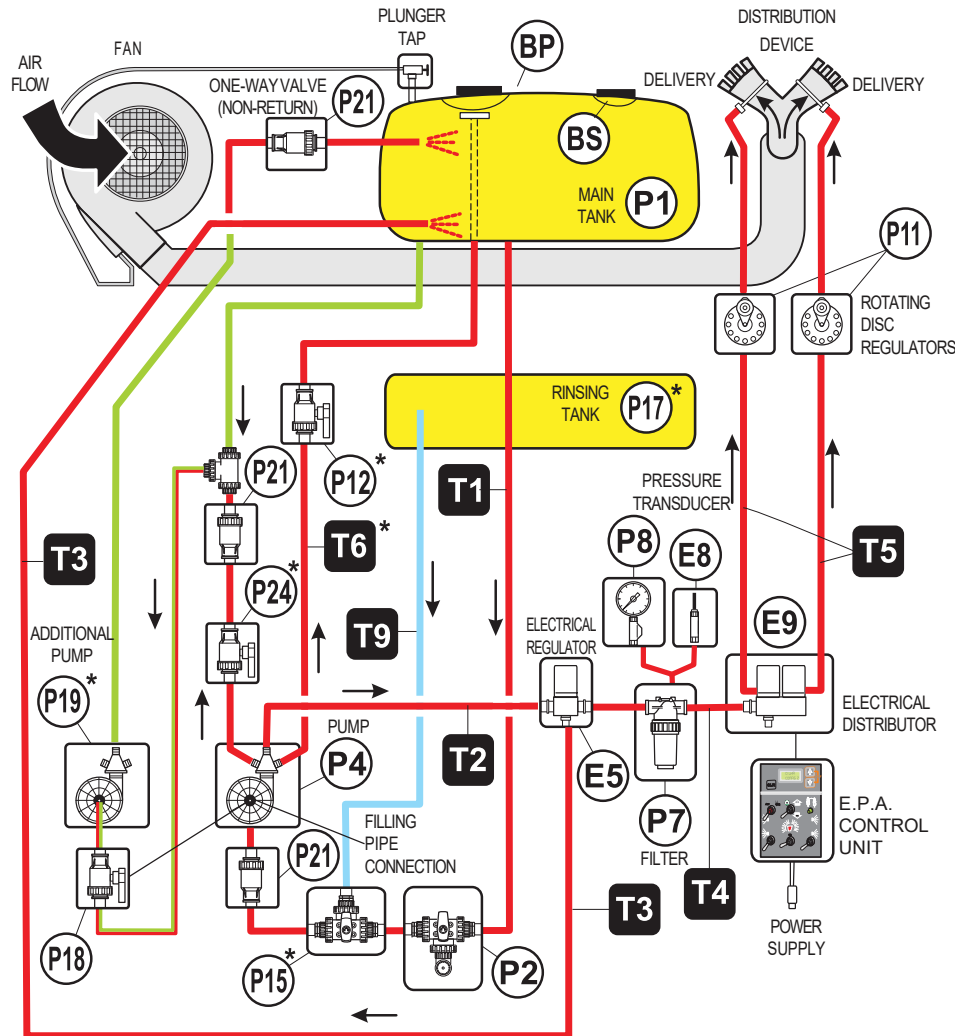

\* For the version in which it is envisaged

00931-

Use and maintenance decals



- CHECK THE OIL LEVEL EVERY 8 HOURS:  
FAN SHAFT BEARINGS

95079



- LUBRICATE EVERY 200 HOURS:  
SUPPORT FOOT with crank regulation

95024



- WARNING: NEVER OPERATE THE SPRAYER WITHOUT LIQUID IN THE TANK

95065

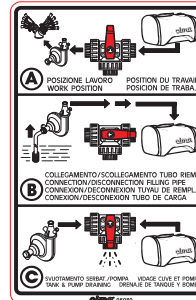

- INDICATION ON THE OPERATION OF THE 3-WAY TAP (P2)

95080

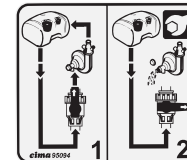

- INDICATIONS ON THE OPERATION OF THE ADDITIONAL PUMP MAINTENANCE TAP (for version in which this is envisaged)

95094



- ADDITIONAL PUMP WARNING LIGHT (for version in which this is envisaged)

95085



- HANDWASHING TANK TAP  
Imprint next to the tap

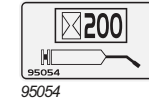

- GREASE EVERY 200 HOURS: FAN BELT-TENSIONER SUPPORT, FREE WHEEL, WHEEL HUBS, STANDARD TRAIL EYE AND STEERING DRAWBAR (for version in which this is envisaged)

95054



- HOOKING POINT FOR THE LIFTING OF THE MACHINE

95059

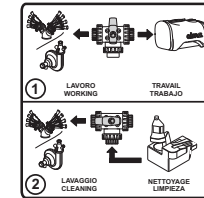

- INDICATIONS ON THE OPERATION OF THE PLANT-WASHING TAP (P15)

95083

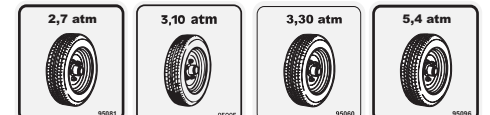

95081 95090 95060 95096

- TIRES PRESSURE



- INDICATION OF THE CHEMICAL EMPLOYED FOR THE TREATMENT

95058



Versions with additional agitation pump

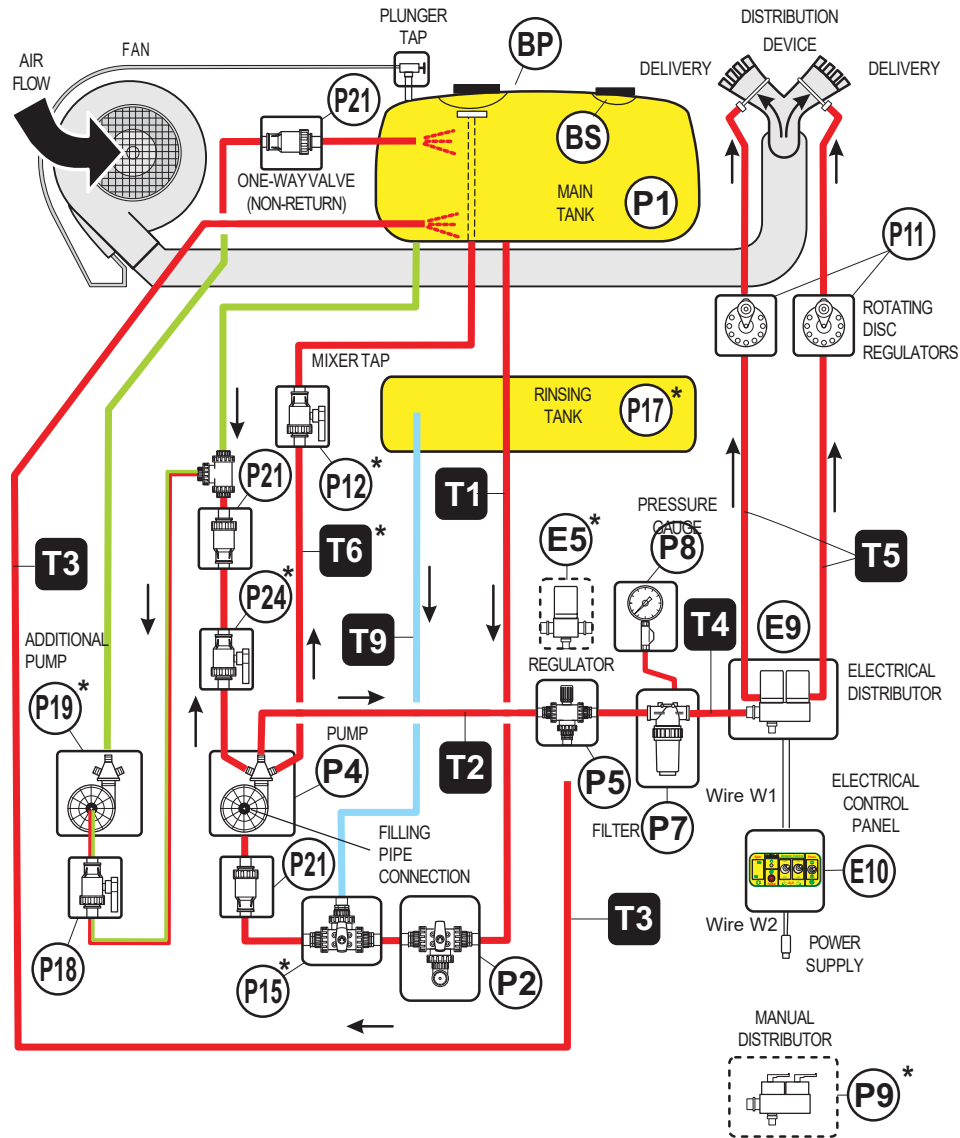

\* For the version in which it is envisaged

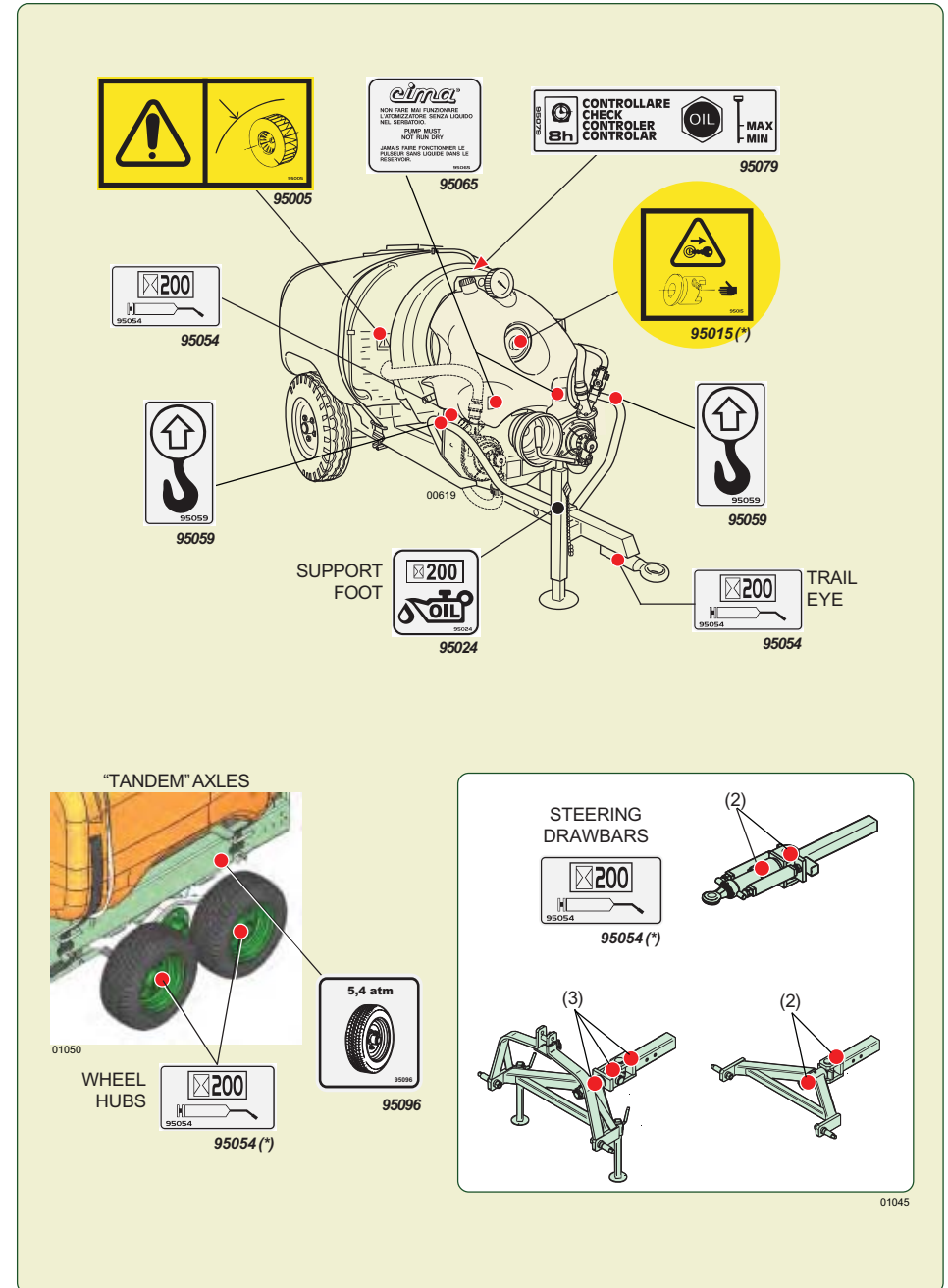





## 15.8 - REPLACEMENT LAMPS REARLIGHTS

(for versions in which is envisaged)



Before working on the electric system disconnect the plug from the tractor .

1. Loosen the glass fixing screws (1) of the rear light.
2. Remove the screws (1) and the glass (2).
3. Replace the non-functioning lamp.

For the replacement you must use:

- use a lamp **ECE P21W 12V** for direction indicator (5)
- use a lamp **ECE P21W 12V** for brake light (4)
- use a lamp **ECE C5W 12V** for rear light (3)

4. Install the new lamp, check functional, allow install the glass (2) and block it with fixing screws (1).

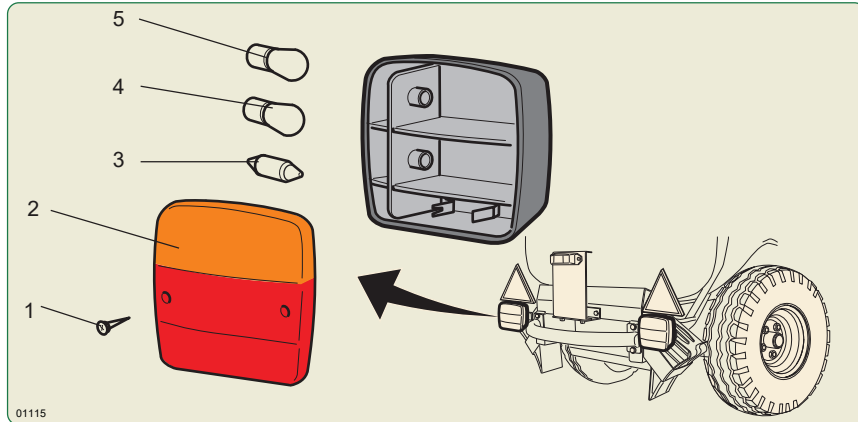

On the identification plate, the full-load weight (PESO T.) of the machine is indicated, measured **WITHOUT** the distribution device, and **WITHOUT** the accessories possibly installed.

In order to calculate the towed weight in operative conditions (at full load), add to the weight indicated on the identification plate (PESO T.), the weight of the distribution device which is used (see "Distribution devices – Use instructions" manual) and the weight of the installed accessories (Par. 4.5.2 - Weight of the accessoires).

- before utilisation, check the correct tightening and securing of the machine's various components, paying particular attention to the safety protections and to the moving parts;
- only utilise protected cardan shafts provided with CE conformity certification. Carry out the assembly only if the drive outlets of both tractor and sprayer are equipped with the protection counter-guard;
- check that the cardan shaft is blocked by the appropriate anti-rotation chains;
- keep people and animals away from the machine before starting it up;
- don't wear articles of clothing that might get caught in moving parts;
- keep to a low speed while negotiating bumps or crossing ditches.
- during the use of the machine, the operator must have a sufficiently good visibility on the working areas, consequently it is recommended to keep both clean and efficient the cab windows and the rear-view mirrors;
- actuate the parking brake when the tractor is stopped on a slope;
- always stop the tractor's engine and actuate the parking brake before carrying out any operation on the sprayer;
- never leave the machine unguarded, when the key is inserted inside the tractor control panel.



- All maintenance and repair operations must be carried out only after having rinsed the tank and flushed the system.
- Before operating within the tank it is necessary to wash it thoroughly with clean water.
- The application of paints and/or solvents, the washing of closed environments and machinery as well as the utilisation of the air flow for purposes other than those expressly concerning the spraying of agro-chemicals is not permitted.
- It is forbidden to enter the tank.

### 3.3.2 - Precautions against the fires

Don't approach either flames or heat sources to the machines. The materials used for manufacturing the machine itself are made by widely using oil derivatives: tanks, pipes, wheels, plastic components; besides, the presence of lubricants and of chemical product residuals make them potentially flammable.



- It is forbidden to perform welding operations if ammonium salts were previously used.
- It is forbidden to use the machine within a potentially explosive environment.

### 3.4 - SAFETY SYSTEMS

All machine moving parts are suitably protected by guards and highlighted through the use of warning decals.



- It is forbidden to use the machine with these guards removed.
- Before removing the protection, stop the tractor's engine and remove the key from the control panel.

The pictures illustrate the machine's guarded parts:

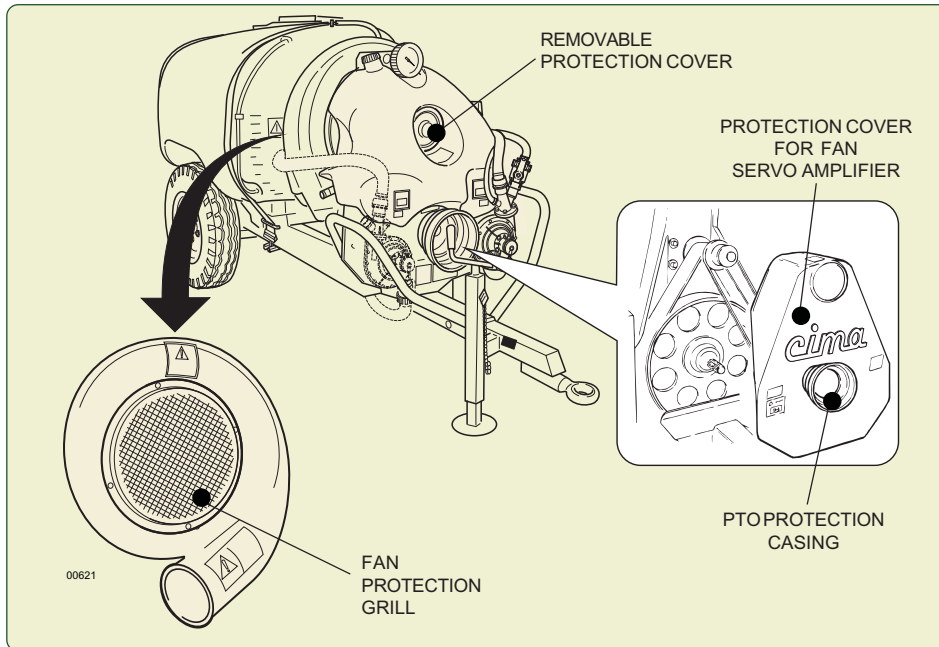

**THE OWNER AND/OR THE OPERATOR OF THE SPRAYER ARE NOT PERMITTED TO MODIFY THE STRUCTURE OR THE SPECIFIC OPERATION OF THE SPRAYER ITSELF. ANY REPAIRING INTERVENTION HAS TO BE CARRIED OUT EITHER AT THE DEALERS' OR AT THE C.I.M.A. S.p.A. AUTHORIZED WORKSHOPS, OTHERWISE ANY KIND OF WARRANTY IMMEDIATELY CEASES AND C.I.M.A. S.p.A. IS CLEARED OF ANY CONSEQUENT AND/OR IMPLIED RESPONSIBILITY.**

### 3.5 - HANDLING OF AGRO-CHEMICALS

The **operator** could become contaminated due to accidental spray, contact or inhalation of products or crop-spraying mixtures.

The **environment** could become polluted by mixture over-spills, puncturing of containers, uncontrolled storage of used and unwashed containers or spillage into waterworks.

### 15.7 - TANK REMOVAL OR REPLACEMENT



This operation has to be carried out by a C.I.M.A. service point



The operation has to be carried out by complete absence of liquid residuals both inside the tank and in the hydraulic circuit.

1. Make the tank free from all the hydraulic and pneumatic connections.
2. Loosen the screw nut (4), for tensioning the tank fastening belt.
3. Remove the split pin (3).
4. Unscrew the belt end (2), in order to make the tank free; carry out the same operation for the second belt (1).
5. Lift the tank and remove it from the frame.

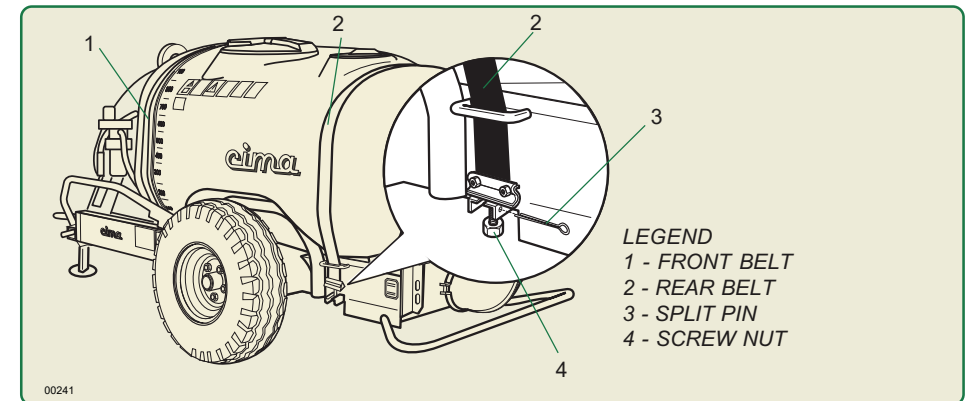

Before reassembling the main tank check the integrity of the rubber supports glued on the frame; if damaged or particularly worn replace them.

6. Position the tank on the frame.
7. Reposition the anchorage belts in their own seats.
8. Screw the regulation nut on each belt so that they are tight enough to firmly secure the tank to the frame.
9. Replace both the safety pins.



The adjustment of the belts takes place during the first 3÷4 hours of use of the atomizer; after this period check and restore the correct tension of the belts so that the perfect block of the main tank to the frame will be guaranteed, this way preventing any damages or breakups of the tank itself.



Before every treatment, check the tension of the tank anchorage belts.

## 15.6.2 - CHECK WITHOUT FLOWMETER



**TESTING OF HYDRAULIC DELIVERY MUST BE MADE WITH THE SPRAYER ON A FLAT SURFACE. THE PROOF IS IN THE DETECTION OF TIME TO PROVIDE A KNOWN QUANTITY CONTENT OF LIQUID IN TANK**

1. Disengage the fan (for versions where it is foreseen): see Paragraph 8.1.a.
2. Close the taps of the 2-way distributor:
  - a. if manual (P9), the levers are to be lowered (horizontally positioned);
  - b. if electric, position to "OFF" the quick-break switches (E10).
3. Fill the tank with about 250 liters of clean water (**USED AS REFERENCE THE MARK OF LEVEL INDICATOR ON THE TANK** - see Paragraphs 8.2/8.3).
4. Engage the fan (for versions where it is foreseen): see Paragraph 8.1.b.



**The claimed performance is obtained with the PTO at 540 rpm. and with the fan running .**

**For correct verification result this condition MUST ALWAYS BE RESPECTED.**

5. Bring the PTO to 540 rpm rotation rate.
6. Open the taps of the 2-way distributor:
  - a. if manual (P9), the levers are to be raised (vertically positioned);
  - b. if electric, position to "ON" the quick-break switches (E10).
7. Regulate the operating pressure, by acting on the pressure regulator (P5) (or electric E5) with the distributor, hand (P9) or electric (E9), open (DISTRIBUTION) and regulate the position of calibration disc (P11) in accord to "Delivery chart" relating to the sprayhead used.
8. Close the taps of the 2-way distributor:
  - a. if manual (P9), the levers are to be lowered (horizontally positioned);
  - b. if electric, position to "OFF" the quick-break switches (E10).
9. Add water to the tank until you reach the mark of 300 liters (reference).
10. Add additional 25 liters of water to the tank, the quantity required for the verification flow, using a graduated container or by weighing the amount payable (1liter = 1 kg).
11. Open the taps of the 2-way distributor (manual or electric) to start delivery.
12. Continue the delivery until the water reaches the mark 300 liters on the level indicator.



**NOTED THE TIME ELAPSED BETWEEN THE RELEASE DELIVERY AND THE ACHIEVEMENT OF MARK 300 LITERS .**

13. Take the flow rate per hour:

apply the formula 
$$Q = \left( \frac{60}{t} \right) \times 25$$

where: **Q**, is the hourly delivery detected (lt./h);  
**t**, is the time measured in minutes and seconds (centesimal)

In order to avoid these risks the preparation and filling operations must be carried out in suitably appointed and adequately equipped sites.



**To use pesticides (purchase, transport, loading, treatment planning, mixture preparation, field transfert, treatment performance, ending treatment liquid waste management, equipment rinsing and waste disposal) you must follow the country rules.**



**Absolutely respect the rules on the label of the product used referring to the dose for hectar and to the compatibility of other products.**

### 3.5.1 - Storage

**Fixed / stationary:** the site used must be well ventilated and secured by lockable doors in order to prevent even accidental access by children or unauthorised persons.

**Mobile:** the carrier equipment must be properly locked and kept under conditions whereby access by children or unauthorised persons can be prevented during the absence of the operator. All full or partially utilised containers must be secured against tipping, falling or breakage during transportation. Both types of storage must:

- have a suitable container for the storing of empty packaging materials should a specific storage area not be available;
- have a clean water supply readily available for washing, by means of a specific container or through connection to the waterworks system;
- have the use of fire extinguishers, should flammable products and substances be stored.



- **All packages, whether whole or partially utilised, must be stored in their original packing and with the warning instructions clearly displayed and legible.**
- **The storage indications must always be scrupulously adhered to, as well as their utilisation and possible disposal as suggested on the product's original packaging.**

### 3.5.2 - Specific equipment

The site at which the preparation and filling out will take place must provide for:

- all the equipment necessary to the precise measuring of both the water quantity and the dose of product to be mixed in the tank at every filling;
- all the equipment and means useful to the preparation of the mixture and for the cleaning of the operator in case of contamination;
- all tools necessary to facilitate the direct introduction of the agro-chemicals in the tank;
- the allocation of clothing and specific equipment in order to avoid contamination by contact or inhalation during the whole operative phase of the intervention;
- the availability of proper equipment able to stop the uncontrolled spilling and flowing of the mixture;
- a retaining valve on the feed pipe when the filling of the tank takes place directly from the waterworks system.

### 3.5.3 - Disposal of empty containers and agro-chemicals residues

Agro-chemicals are classified as "special" waste and their disposal must take place separately from "urban" wastes.



Empty packaging and contaminated containers to be done away with cannot be dispersed, burned or buried. The washing water for the cisterns and the tools utilised for the preparation of mixtures cannot be emptied on the ground, spilled into the sewage system or in waterways and rivers.

The disposal of special wastes is regulated by specific norms. In order to perform this operation it is necessary to obtain the relevant information from the Local Offices specifically appointed to rule on this subject. The non compliance with these regulations can cause considerable damage to persons and animals as well as polluting the environment.

### 3.5.4 - Personal means of protection

The toxicity of agro-chemicals forces persons working with them to wear adequate protective clothing and accessories in order to avoid risks of contamination by contact or inhalation.

In each of the following work stages:

- filling of tanks and adding of the agro-chemical,
- dusting and spraying,
- adjusting of the sprayer,
- emptying and cleaning of the tank,
- replacement of the agro-chemical,
- maintenance interventions,

it is necessary to wear personal protection clothing and accessories.

The following must be worn:

- Polyethylene or polyvinyl gloves.
- Full, waterproof cotton overalls, in order to guarantee transpiration, fitted with polypropylene side flaps. In commerce, one-time 'tyvek' overalls are available which, after use (see picture), must be disposed of according to the modalities applicable to toxic waste.
- A protective half-mask in polychloroprene rubber with 1 or 2 filters. Filters for gases and organic fumes, of European A1-class vapours, are envisaged and these can be combined with anti-dust models of P1 European class, for harmful mists and powders, or P2, for harmful and toxic mists and powders.



The filters must be replaced:

- when the smell/taste of agro-chemicals can be detected, and that of active A1-class carbons;
- when difficulty in breathing is experienced for the anti-dust filters of class P1 and P2. In any case it is necessary to make use of all personal means of protection as suggested by the manufacturers.

## 15.6. - CHECK HYDRAULIC DELIVERY

THE CHECK IS CONSIDERED TO BE SUCCESSFUL (THE MACHINE IS PROPERLY CALIBRATED) WHEN THE CALCULATED VALUE "Q" CORRESPONDS TO THE VALUE INDICATED ON THE "FLOW CHART" TABLE WITH A ±2.5% TOLERANCE.

If the resulting values are different, check the efficiency of the pipes, the fittings, the pressure gauge and the correct positioning of the calibration discs (P11). If necessary, replace the damaged or defective parts and repeat the test.

### 15.6.1 - CHECK WITH FLOWMETER

1. Disengage the fan (for versions where it is foreseen): see Paragraph 8.1.a.
2. Fill the tank with enough clean water to make the test.
3. Turn the 3-way valve (P2) to "B" position (Maintenance).
4. Disconnect the pipe (T4) from the electrical distributor (E9) or from manual distributor (P9).
5. Connect the appropriate flowmeter for the measurements to be made, between the pipe (T4) and the electrical distributor (E9) or the manual distributor (P9). If necessary, remove the fitting (P26) and use the fittings suitable for connecting the flowmeter.

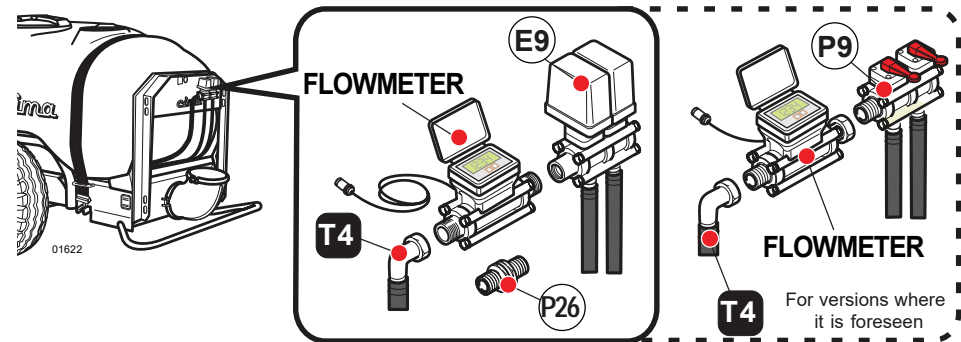

6. Turn the 3-way valve (P2) to "A" position (Work - phytosanitary products distribution).
7. Engage the fan (for versions where it is foreseen): see Paragraph 8.1.b..



The declared performance is achieved with the PtO at 540 rpm and with the fan running. For a correct result of the check, this condition MUST ALWAYS BE RESPECTED.

8. Run the PtO at 540 rpm.
9. Open the taps of the 2-way distributor:
  - a. if electric (E10), set the switches to "ON"
  - b. if manual (P9) turn the levers vertically
10. Adjust the working pressure by using the manual pressure regulator (P5) (or the electric one E5) and the position of the calibration disc (P11) according to indications given on the "flow charts" for the distribution device (sprayhead) used.
11. Take the flow rate per hour.

## 15.5 - TANK LEVEL GAUGE CLEANING

1. With a suitable pliers release the clamp (1 and 2) fixing transparent tube of the level gauge.
2. Take off and remove the transparent tube (3).
3. Remove the red plastic ball (4) .
4. Clean, whit clean water, the transparent tube both in and outside.

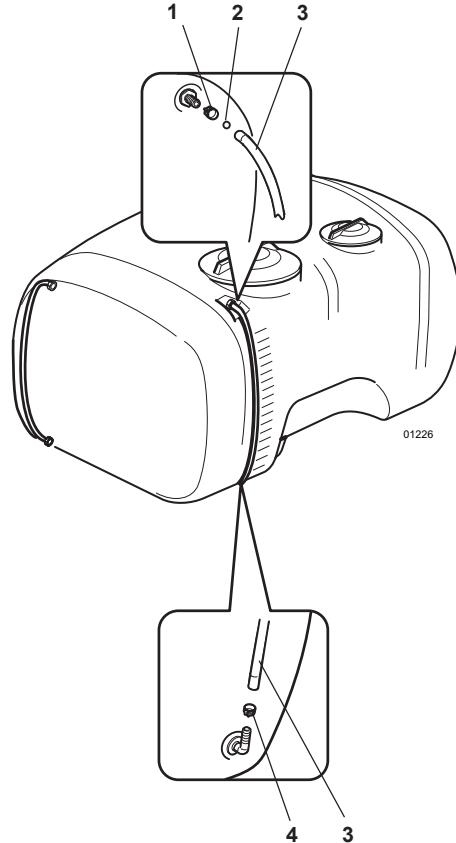

**Gather the rinsing water in a proper container provided to be waste according to the rules or used again, putting it in the tank, for a next treatment if suitable with the product to be used.**

5. If the cleaning is not satisfactory, replace the transparent tube (3).

**Waste the transparent tube according to the same method as per the pesticides container.**

6. Put the red plastic ball (4) into the transparent tube (3).
7. Install the transparent tube (3) making slip it on the rubber fittings.
8. Place the clamps (1 and 2) fixing the transparent tube (3) of the level gauge and close them with a suitable pliers.

## 4 MACHINE'S STRUCTURAL ANALYSIS 4

The pictures indicate the position of the main components of the sprayer.

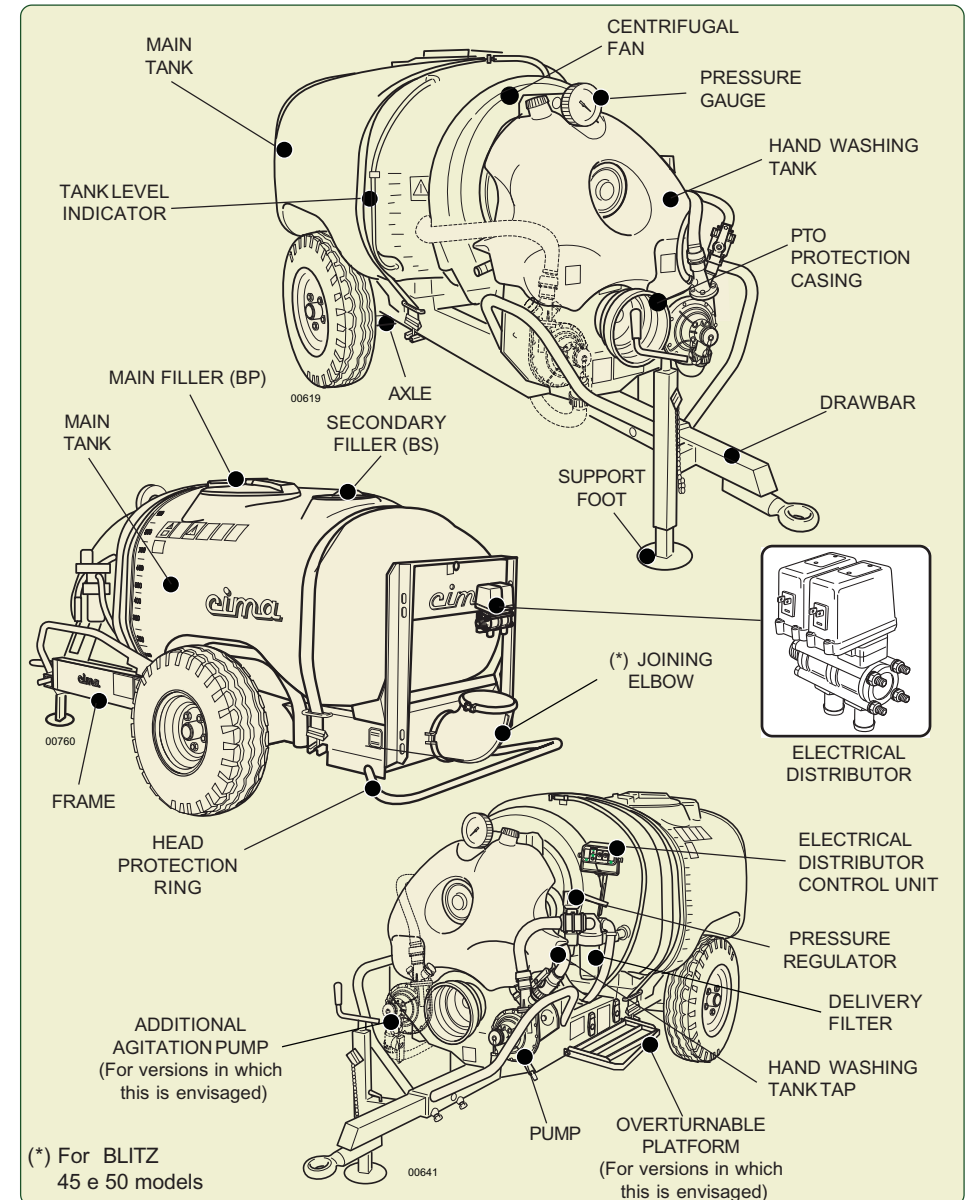

(\*) For BLITZ  
45 e 50 models

## 4.1 FRAME WITH DRAWBAR

**DRAWBAR WITH STANDARD TRAIL EYE.** It is inserted in the frame front section; its position is regulated by means of the insertion of a through screw, provided with a self-locking screw nut. The drawbar is locked by means of the two lateral screws, foreseen for this purpose

- Adjustable in **height** for 13 cm (16 cm for the 1500-2000 litres BLITZ 55 models).
- Adjustable in **length**, with displacements of 8 – 16 – 24 – 32 cm.



After every regulation, carefully tighten the two fastening screws

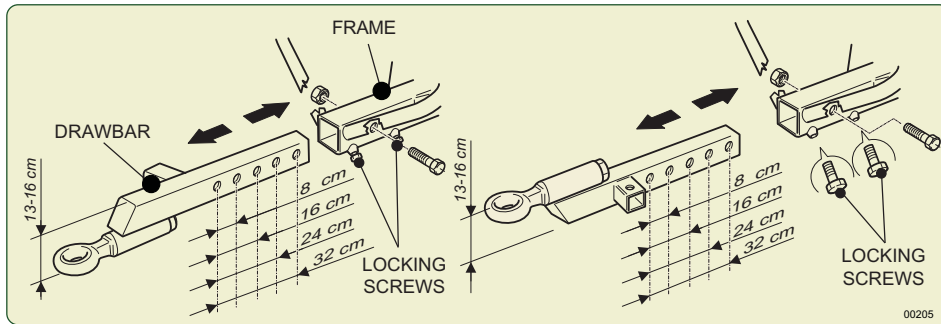

**BRACKET DRAWBAR (for the versions on which it is foreseen).** It's inserted in the frame front section; its position is regulated by means of the insertion of a through screw, provided with a self-locking screw nut. The drawbar is locked by means of the two lateral screws.

- Adjustable in **height** for 13 cm (16 cm for the 1500-2000 litres BLITZ 55 models).
- Adjustable in **length**, with displacements of 8 and 16 cm.



After every regulation, carefully tighten the two fastening screws.

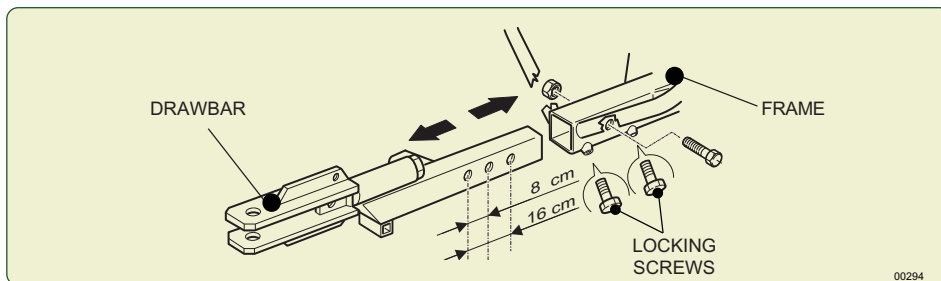

## 15.4 - INSPECTION AND CLEANING PUMP FILTER



The pump is provided by the suction side of a filter to prevent the accidental entry of foreign bodies in the pump body, such a possibility does not constitute a hazard and can only cause damage to the impeller shown by a drop in pressure reported by gauge..

The clogging of the filter pump causing an immediate lowering of pressure delivery. If necessary check the cleanliness of the filter:

1. Position the lever of the three-way cock (P2) in position "B".
2. For the versions fitted with spray-line rinsing tank position the lever of cock (P24) in position "c".
3. Unscrew the plug (1) and eventually remove the foreign body present in to the filter.
4. If necessary, unscrew the nuts (2) and remove the filter (4), to clean completely.
5. Replace the filter by paying attention to the conditions and the proper placement of the O.Ring (5).
6. Close the screw plug (1).
7. For the versions fitted with spray-line rinsing tank position the lever of the cock (P24) in position "a".
8. Position the lever of the three-way cock (P2) in position "A" - WORKING INSPECTION AND CLEANING PUMP FILTER

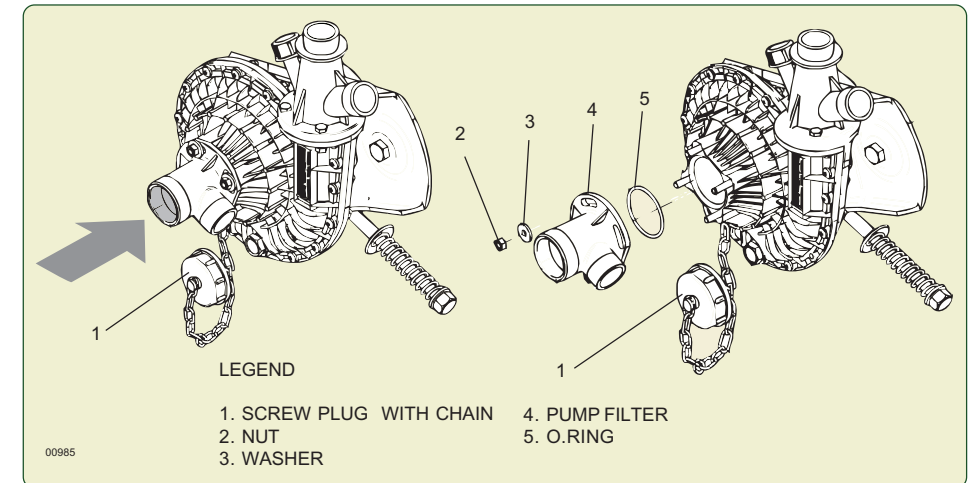

### Additional agitation pump

1. Close the cock (P18): position "c".
2. Unscrew the plug (1) and eventually remove the foreign body present in to the filter.
3. If necessary, unscrew the nuts (2) and remove the filter (4), to clean completely.
4. Replace the filter by paying attention to the conditions and the proper placement of the O.Ring (5).
5. Close the screw plug (1).
6. Open the cock (P18): position "a".

## 15.2. - REPLACEMENT OF ELECTRICAL PANEL'S FUSES

1. Replace the faulty fuse and screw back the cover.

\* Fuse: 10 A, delayed.



ANY OTHER INTERVENTION HAS TO BE CARRIED OUT AT A C.I.M.A. CUSTOMERS' SERVICING CENTER.

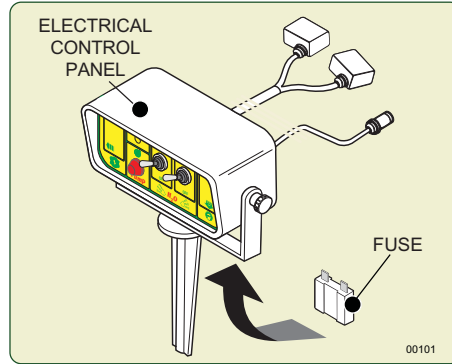

## 15.3. - PRESSURE GAUGE REPLACEMENT

1. Unscrew and remove the defective pressure gauge ;
2. Replace the pressure gauge.

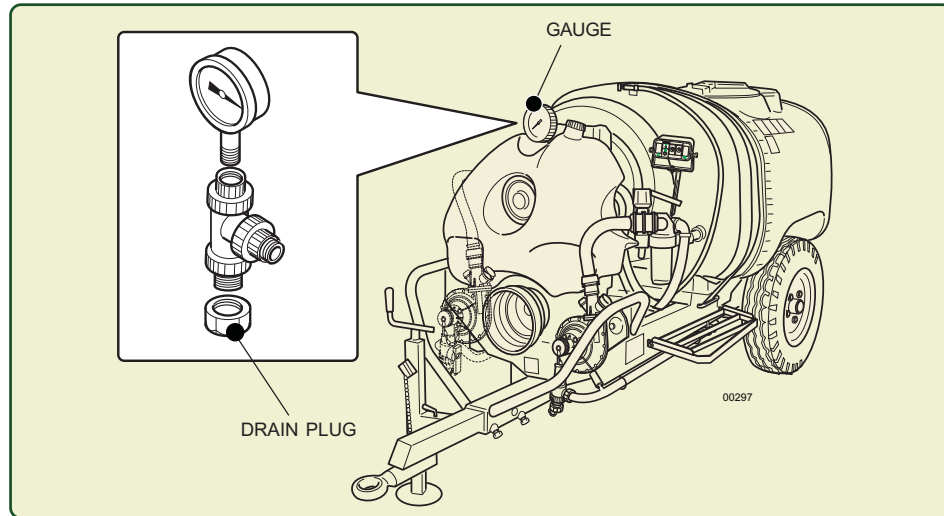

ANY OTHER INTERVENTION HAS TO BE CARRIED OUT AT A C.I.M.A. CUSTOMERS' SERVICING CENTER.

SUPPORT FOOT with crank regulation.



**ALWAYS** use the adjustable support foot, in order to stabilize the sprayer when it isn't hitched to the tractor.

The adjustable support foot can be fastened to the sprayer in three different positions, according with the different operative requirements:

**Position A** - applied to the drawbar, it assures the necessary stability to the sprayer, when it isn't hitched to the tractor.

**Position B** - vertically applied to the frame, it allows to regulate the length and to modify the drawbar height, after the sprayers has been linked to the tractor.



**Work ONLY** when the sprayer is linked to the tractor: otherwise the sprayer stability is not guaranteed.

**Posizione C** - horizontally applied to the frame, after that the sprayer was hitched to the tractor, it allows to use the sprayer itself (**treatment position**).

The figure shows the adjustable support foot three possible positions.

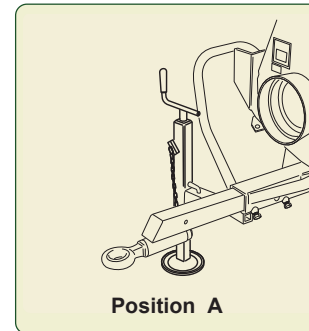

Position A

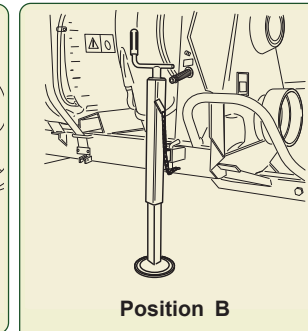

Position B

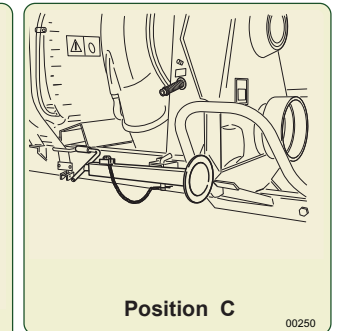

Position C



**ONLY** with the sprayer is linked to the tractor



During the sprayer operation, the support foot has **ALWAYS** to be positioned on "C".



The Blitz 55 sprayers, with 2000 liters tank, are equipped with a jockey wheel with crank regulation; use is the same as for the adjustable support foot.

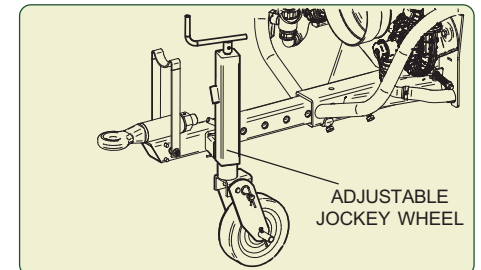

**SUPPORT FOOT** for sprayers equipped with bracket drawbar or steering drawbar for the 3-point connection, stabilizes the sprayer when it is not linked to the tractor.



**ALWAYS USE** the support foot to stabilize the sprayer when not linked to the tractor.

The support foot can be set at the sprayer in two different positions as needed:

**Pos. A** - vertically applied to the bracket drawbar, it allows the support and stabilizes the sprayer when it is not linked to the tractor stabilizes the sprayer when it is not linked to the tractor.

**Pos. B** - horizontally applied to the bracket drawbar, after that the sprayer was hitched to the tractor, it allows to use the sprayer itself (**treatment position**).



During the sprayer operation, the support foot has **ALWAYS** to be positioned on "B".

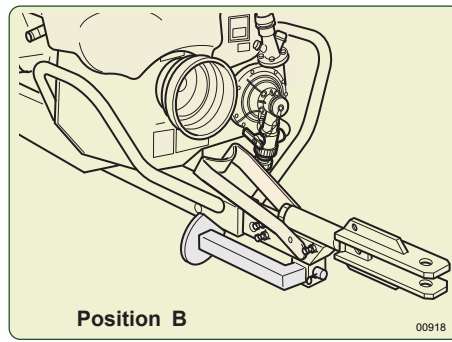
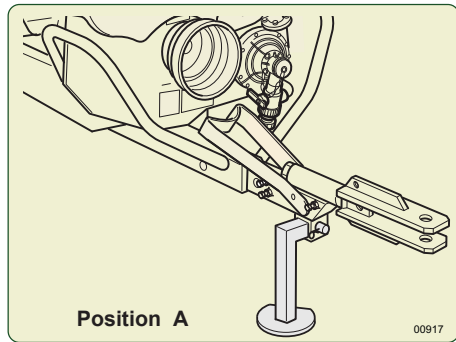

**SUPPORT BRACKET** mounted on the drawbar, in order to house the transmission shaft when the machine isn't hitched to the tractor.



When the transmission shaft is mounted on the 2 PTO, the bracket has always to be lowered.

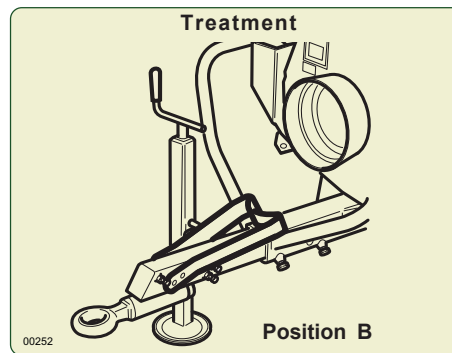
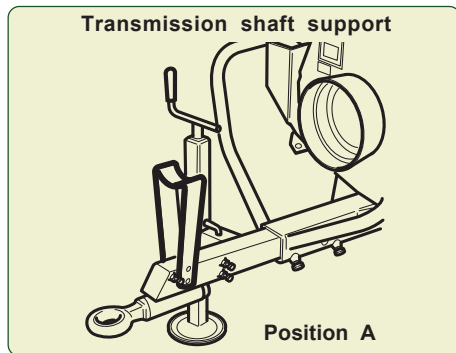

**THE OWNER AND/OR THE OPERATOR OF THE SPRAYER ARE NOT PERMITTED TO MODIFY THE STRUCTURE OR THE SPECIFIC OPERATION OF THE SPRAYER ITSELF. ANY REPAIRING INTERVENTION HAS TO BE CARRIED OUT EITHER AT THE DEALERS' OR AT THE C.I.M.A. S.p.A. AUTHORIZED WORKSHOPS, OTHERWISE ANY KIND OF WARRANTY IMMEDIATELY CEASES AND C.I.M.A. S.p.A. IS CLEARED OF ANY CONSEQUENT AND/OR IMPLIED RESPONSIBILITY.**



**Stop the engine and remove the key from the tractor's control panel before any operation on the sprayer.**



### 15.1 - REPLACEMENT OF PUMP CONTROL BELT

1. Remove hands-washing tank.
2. Remove the fan assembly protection, by unscrewing the screw fastening it to the frame.
3. Completely unscrew the tightener spring adjusting screw: the pump support plate will so freely turn.
4. Remove the worn out belt, by getting it first loose from the pump pulley and then from the upper control pulley.
5. Insert the belt first into the race of the upper pulley and then into the race of the pump pulley.
6. Reinstall the spring of the belt-tensioner according to the suggested tensioning conditions.
7. Mount back the fan assembly protection casing.
8. Install hands-washing tank.

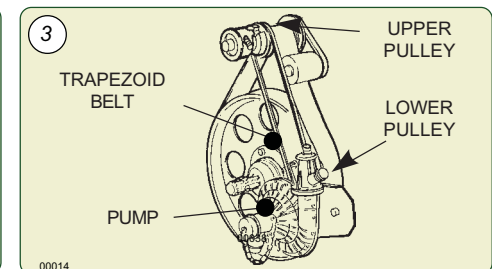
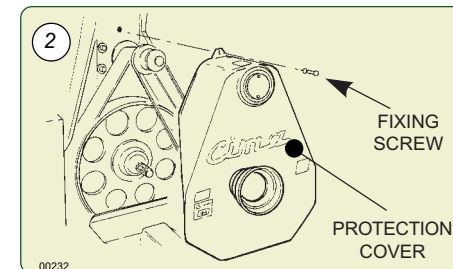
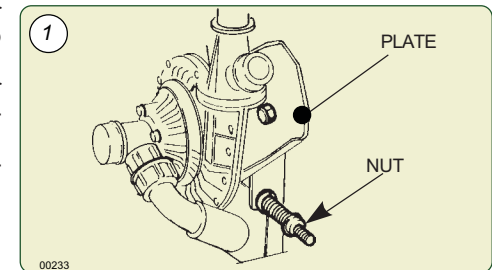

Carefully tighten the screws that were undone during the belt replacement.



**J. FAULT: No spraying action delivered: totally or only on the one side of the distribution device**

1. CAUSE: Manual distributor (P8) taps dirty or clogged, or pump suction piping clogged by hardened product deposits.  
**REMEDY:** Clean.
- 1b. CAUSE: Electrical distributor (E9) taps blocked by incrustations in the closed position.  
**REMEDY:** Remove the cover, act on the opening/closing control rod.  
Clean the distributor.
2. CAUSE Fuses of the electrical control panel (E10)  
**REMEDY:** Replace the fuses.
- 3b. CAUSE: Power cable W1 of the electrical panel interrupted or oxidized connectors of the electric distributor (E9)  
**REMEDY:** Connect and possibly replace the defective components correctly.
4. CAUSE: Defective electrical connections.  
**REMEDY:** Address a C.I.M.A. point of "Sale and Service".
5. CAUSE: Pump defective (only in case total delivery missing).  
**REMEDY:** Address a C.I.M.A. point of "Sale and Service".
6. CAUSE: Broken pump belt.  
**REMEDY:** Replace the belt (See Paragraph 15.1).



**THE CAUSES AND REMEDIES FOR THE FAULTS CONCERNING THE DELIVERY OF THE SPRAYING BY ONE OR MORE DIFFUSERS ARE INDICATED IN THE USE AND MAINTENANCE MANUAL OF EACH SPRAYHEAD.**

**K. FAULT: Anomalous consumption of oil of the fan support.**

1. CAUSE: Oil drain plug not adequately closed.  
**REMEDY:** Check, reposition and adequately close then handle the filling up of the oil level.
2. CAUSE: Damaged flexible oil waste pipe or damaged pipe fixing clamp.  
**REMEDY:** Check, adequately then handle the filling up of the oil level. Replace the damaged parts: Address a C.I.M.A. point of "Sale and Service".
3. CAUSE: Drawings from the support mechanical seals.  
**REMEDY:** Address a C.I.M.A. point of "Sale and Service".

**L. FAULT: Noisiness (ticking) coming from the upper part of the mechanical drive at low runnings, above all when slowing down.**

2. CAUSE: Consumption of the damping elements of the fan release.  
**REMEDY:** Eventually have it replaced; address a C.I.M.A. point of "Sale and Service".

**M. FAULT: Noisiness (ticking) coming from the lower part of the mechanical drive at low runnings, above all when slowing down.**

1. CAUSE: Lack of grease in the multiplier free wheel.  
**REMEDY:** Grease the free wheel.

**4.2 - STEERING DRAWBAR** (on demand)

**IT IS NECESSARY TO USE THE HOMOCYNETIC CARDAN SHAFT.**

The steering drawbar has to be mounted instead of the standard drawbar.

It has to be fixed to the frame by a through screw provided with a self-locking nut and locked by means of the two lateral screws.

**4.2.1. - Drawbar for the towl hook**

It has a coupling plate to the tractor rear hook. On the drawbar a support bracket is mounted for housing the cardan shaft when the sprayer is not hitched to the tractor. The frame is the same as the one of the standard drawbar. (see point (4.1)).

**4.2.2. - Drawbar for the 3-point connection**

It has a coupling triangle with two pins and the 3-point pin arranged for the hydraulic power-lift - "1" and "2" category, or only a coupling bar for the connection with the two lower pins.

- Category "1": 22 mm. diam.pins - 19 mm. diam. 3-point pin.
- Category "2": 28,5 mm. diam.pins - 25 mm. diam. 3-point pin.

The frame features are the same ones of the standard drawbar. (see point (4.1)).

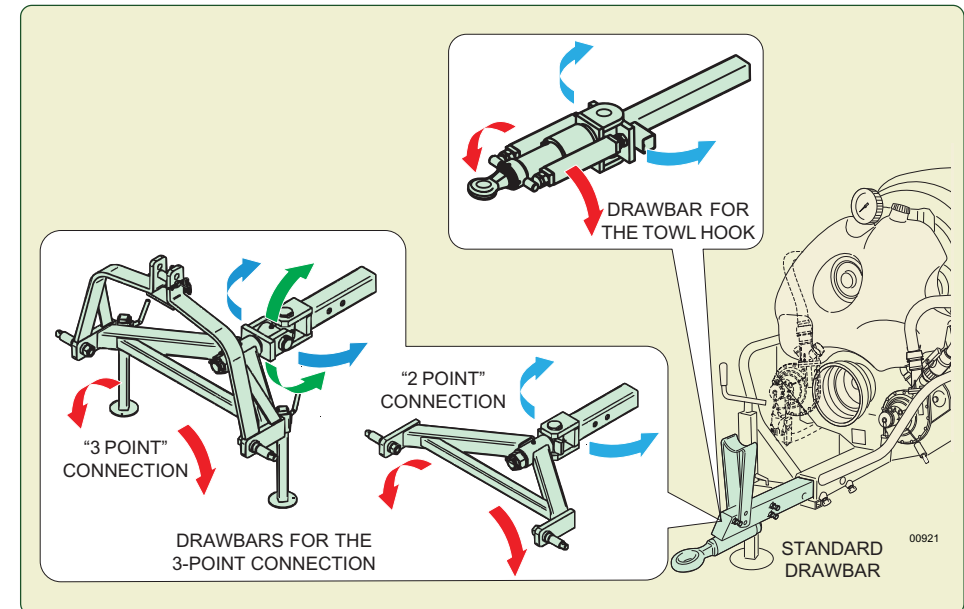

**AXLE.** It is fastened by means of four bolts to the frame. The axle can be mounted in two different positions, so modifying the wheel base between the wheels and the drawbar. The wheels' axle shafts, inserted in the frame axle and locked there by some especially foreseen screws, allow to regulate the **track width**, by adapting it to the intervention requirements.

— The height with respect to the ground can be regulated. (The misalignment between the axle shaft and the wheels' hub allows a variation of 12 cm). It is enough to turn the axle shafts.

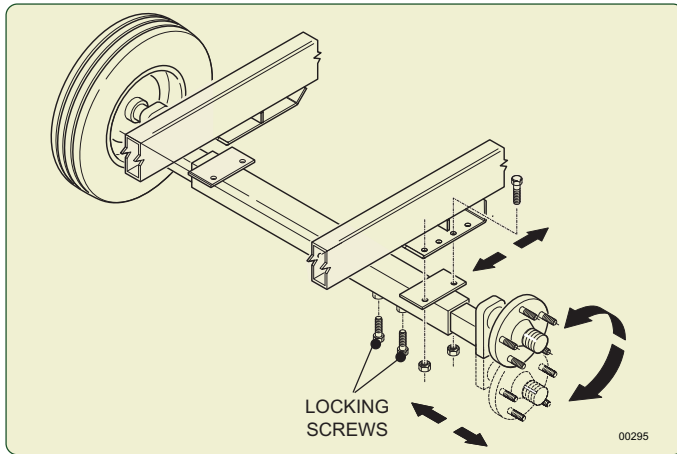

**After every regulation, carefully tighten all the screws and the bolts concerned by the intervention. THE RESPONSIBILITY FOR THE REGULATION, ASSEMBLY AND DISASSEMBLY OPERATIONS OF THE WHEELS IS CHARGED TO THE OPERATOR, WHO HAS TO PREPARE AND TO ASSURE THE NECESSARY CONDITIONS FOR A COMPLETE SAFETY AGAINST ANY POSSIBLE ACCIDENT.**

**WHEELS.** The wheels' hubs are equipped with grease nipples for the bearings lubrication (see 14.1). The tyres' size and the operating pressure are indicated at step 4.5.2.

**HEAD PROTECTION RING.** It is applied behind the machine, in order to protect the distribution devices (heads). It has to be mounted in the most efficacious position, according with the working conditions and with the kind of head.

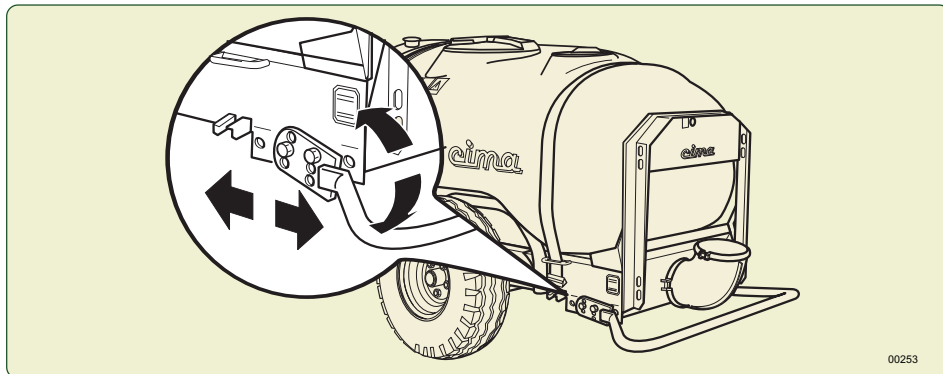

3. CAUSE: Wrong positioning of the circuit-washer faucet (P15) with the circuit-washer tank empty.  
**REMEDY:** Position the lever of the faucet correctly (P15 - pos". 1") and fill the circuit-washer tank.
4. CAUSE: Lack of seal of the O-Ring gasket of the pump suction connection (cone).  
**REMEDY:** check the correct assembling and the efficiency of the O-Ring gasket, if necessary replace the gasket.

**E. FAULT: Vibrations of fan unit.**

1. CAUSE: Dirty fan.  
**REMEDY:** Wash. (It is advisable to refer a C.I.M.A. point of "Sale and Service".
2. CAUSE: The tractor and of the atomizer PTOs are not lined up or their position determines the overcoming of the maximum work angle of the drive cardan shaft.  
**REMEDY:** Position the 2 PTOs so that the drive cardan shaft can work correctly (see Paragraph 5.2.1).

**F. FAULT: Anomalous and continuous noisiness together with vibrations of the fan group.**

1. CAUSE: Breaking of the fan shaft bearings.  
**REMEDY:** Address a C.I.M.A. point of "Sale and Service".
2. CAUSE: Interference fan - case.  
**REMEDY:** Address a C.I.M.A. point of "Sale and Service".

**G. FAULT: Intermittent operation of the whole distribution device**

1. CAUSE: Lack of seal of the hydraulic circuit that goes from the tank (T1) suction pipes to the electrovalves (E7) or hand distributor (P8).  
**REMEDY:** Carefully inspect all the points at which suction of air can take place, including as well those at which no liquid seepage is detected. Check the proper tightening of ring nuts, fittings and clamps. Check the efficiency of the sealers and the integrity of the piping. Reinststate the efficiency and replace parts that might have been found to be defective.

**H. FAULT: Intermittent spraying only on the one side of the distribution device**

1. CAUSE: Faulty sealing of the hydraulic circuit going from the manual (P8) or electrical (E7) distributor to the distribution point involved.  
**REMEDY:** As per point G.1.

**I. FAULT: No spraying action delivered: totally.**

1. CAUSE: Clogging up of the grill/filter on the pump, of the pump suction inside the tank or suction pipes of pump clogged up with deposits of hardened plant protection product.  
**REMEDY:** Clean.

**A. FAULT:** By utilising the filler piping the pump doesn't operate (suction)



It is necessary to disengage the drive outlet (PTO) and wait for it to stop rotating before repeating the filling operation.

1. CAUSE: the quantity of water poured into the tank is insufficient to trigger the pump.  
**REMEDY:** Add water to the tank until the pump starts its cycle.
2. CAUSE: the filler piping sucks in air.  
**REMEDY:** Completely submerge the suction filter of the filler piping.
3. CAUSE The pump filter is clogged.  
**REMEDY:** Clean the filter
4. CAUSE Lack of seal of the pipes.  
**REMEDY:** Check the tightening of ring nuts, fittings and clamps. Check the efficiency of sealers and that piping elements are not cracked or broken. Replace parts that are possibly found to be defective.
5. CAUSE Slipping of the pump's belt.  
**REMEDY:** Check the tension of the belt-tensioner's spring. (4+5 cm).
6. CAUSE The pump's belt might be broken.  
**REMEDY:** Replace the belt.

**B. FAULT:** Leakage and dripping from the pump

1. CAUSE Non-sealing of the fittings and clamps connecting the piping to the pump.  
**REMEDY:** Check for proper tightening of ring nuts and clamps. Check the efficiency of the sealers. Replace parts that are possibly found to be defective.
2. CAUSE Mechanical sealing defective.  
**REMEDY:** Address a C.I.M.A. point of "Sale and Service".

**C. FAULT:** Drop in pressure of the hydraulic circuit signalled by the gauge

1. CAUSE Dirty filter.  
**REMEDY:** Clean the cartridge
2. CAUSE The pump filter is clogged.  
**REMEDY:** Clean the filter
3. CAUSE: Faulty sealing of the hydraulic circuit.  
**REMEDY:** Check the operation of the pump and the tension of its belt. Check the proper tightening of ring nuts, fittings and clamps. Check the efficiency of the sealers and the integrity of the piping. Replace the parts that are possibly found to be defective.
4. CAUSE: Gauge defective.  
**REMEDY:** Replace the pressure gauge.
5. CAUSE: Suction or gauge connection pipe clogged.  
**REMEDY:** Clean.

**D. FAULT:** Variations in the pressure of the hydraulic circuit (marked by the gauge)

1. CAUSE Lack of seal of the pipes and/or the valves.  
**REMEDY:** Check the clamping of the ring nuts, the connections and the clamps. Verify the efficiency of the gaskets and the integrity of the pipes. Replace the possibly defective parts.
2. CAUSE: Residue of product at the entrance of the gauge  
**REMEDY:** Clean.

**4.3 - FAN SERVO AMPLIFIER**

It is positioned in the unit front section and protected by a plastic casing.

**Servo amplifier**

It is equipped with an automatic tensioner of the driving poly-V belts that keeps the belt tension constant, avoiding slipping and wear. A **free-wheeling gear** (for the version where foreseen) is included between the Power Take-off of the servo amplifier and the fan control pulley (refer to the picture).

In case of sudden decelerations or unexpected engine stoppage, this allows the fan to continue its free rotation, thus avoiding extreme mechanical stresses to be transmitted to the drive members

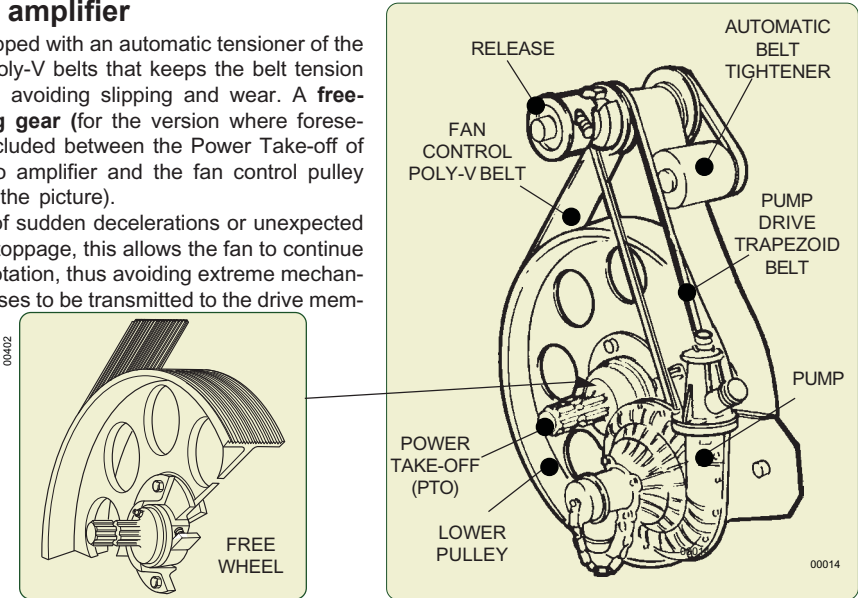

**Centrifugal fan**

The **front-engaging clutch** assembled on the fan shaft allows the operation of the centrifugal pump without the fan (for versions in which this is envisaged).

An air intake predisposed on the casing external edge is connected, by means of a pipe equipped with a cock, to the tank inner agitator.

Through this tap it is possible to carry out or exclude pneumatic agitation.

The closed vanes-type impeller is realized in dynamically balanced sheet steel; the air intake opening on the casing is protected by a grating, especially foreseen for this purpose.

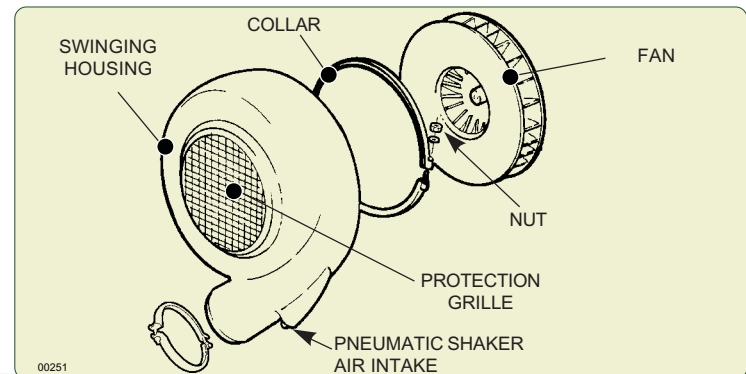

## 4.4 - HYDRAULIC CIRCUIT COMPONENTS

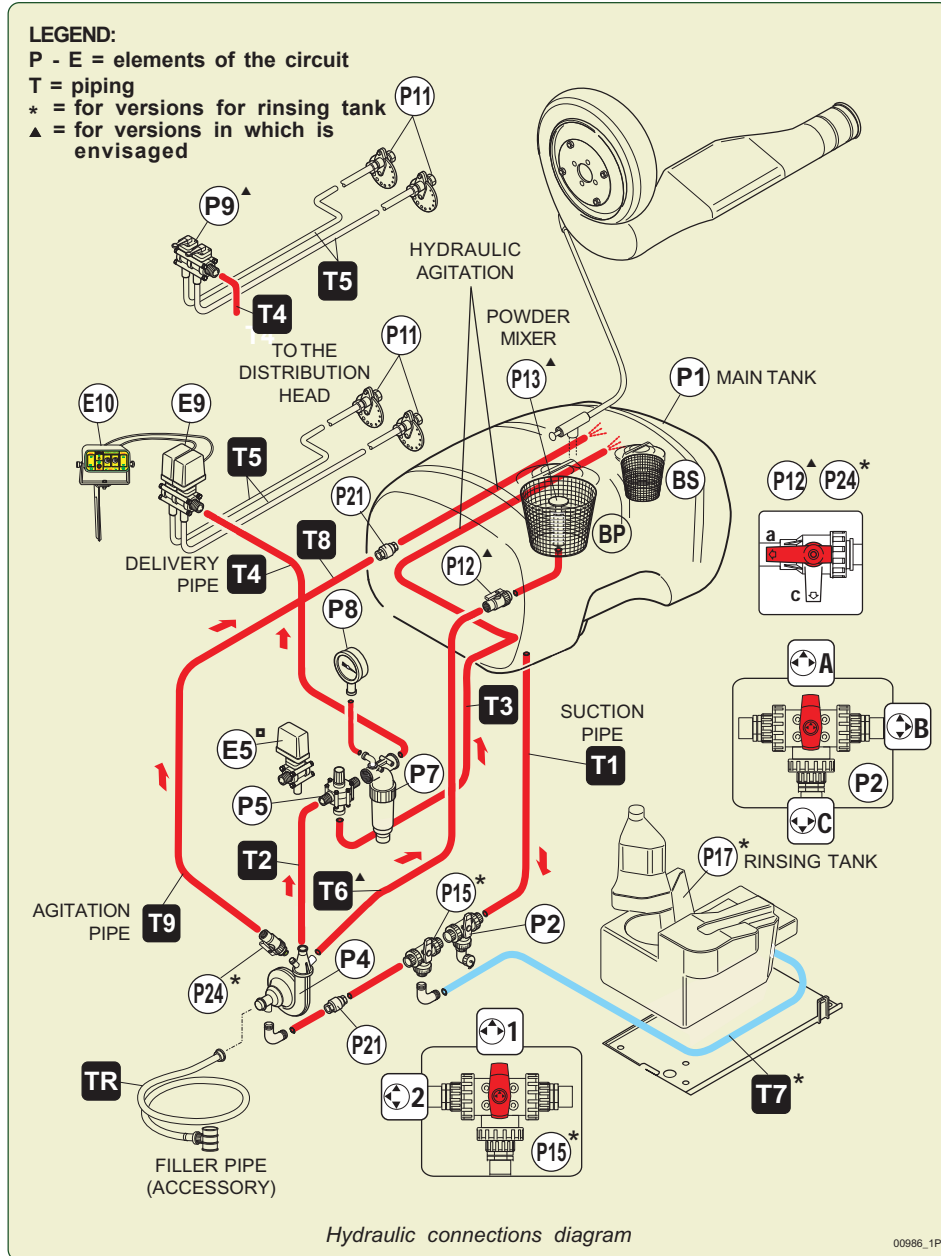

## 13.9 - TABLE OF MAINTENANCE OPERATIONS

CHECK	SEASON START TREATMENTS	BEFORE EVERY TREATMENTS	END OF EVERY TREATMENTS	SEASON-END TREATMENT	RECOMMENDED FREQUENCY
Fan belt-tensioner spring: CHECK LENGHT 9 – 12 cm	YES	YES	**	**	**
Pump belt-tensioner spring: CHECK LENGHT 4 – 5 cm	YES	YES	**	**	**
Fan shaft support: CHECK OIL LEVEL (for oil lubricated models)	YES	YES	**	**	8
Fan shaft support: CHANGE OIL (for oil lubricated models)	**	**	**	YES	1 year
Tank: CHECK BELT CONDITION AND PROPER TIGHTENING	YES	YES	**	**	**
Fan belt-tensioner support: GREASING	**	**	**	YES	200 hours
Free wheel: GREASING	**	**	**	YES	200 hours
Wheels bearings: GREASING	**	**	**	YES	200 hours
Support foot : LUBRICATING	**	**	**	YES	200 hours
Filter: CHECK CLEANING	YES	YES	YES	YES	**
Tank level gauge: CHECK CLEANING AND GOOD CONDITIONS	YES	YES	YES	YES	**
Fittings and piping: CHECK GOOD CONDITIONS	YES	YES	**	YES	**
Clamps and fittings: CHECK FOR INTEGRITY, PERFECT SEALING AND TIGHTENING	YES	YES	**	**	**
Pressure gauge drain plug: UNSCREW AND CLEAN	**	**	YES	YES	**
Drawbar: CHECK THE SCREWS AND FIXING BOLT TIGHTENING	YES	YES	**	YES	**
Steering drawbar (for versions in which this envisaged): GREASING	**	**	**	YES	200 hours
Wheels: CHECK THE SCREW NUTS TIGHTENING AND TYRES PRESSURE	YES	YES	**	YES	**
Axle and Wheel hubs: CHECK THE NUT TIGHTENING AND CHECK THE BOLT TIGHTENING	YES	YES	**	YES	**
Hydraulic circuit and tank: COMPLETELY DRAIN AND WASH	**	**	YES	YES	**
Sprayer: EXTERIOR WASHING	**	**	YES	YES	**
Sprayer: STORAGE	**	**	**	YES	**

### 13.7 - PUMP BELT TENSIONER

Check length "L" of the spring (refer to picture): it should be in tension between 4 and 5 cm.

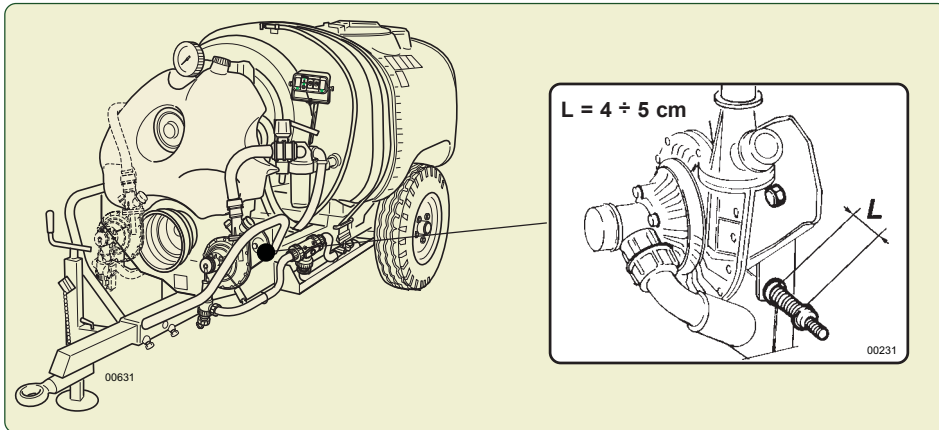

If the value measured exceeds 5 cm, tighten the belt tightener screw, up to get the minimum length (4 cm).

### 13.8 - MAIN TANK FASTENING BELT



The adjustment of the belts takes place during the first 3÷4 hours of use of the atomizer; after this period check and restore the correct tension of the belts so that the perfect block of the main tank to the frame will be guaranteed, this way preventing any damages or breakups of the tank itself.

Check the tension of the fixing belts of the main tank to the frame. To restore the correct tension of the belts screw in the register screw (4) on both sides of the tank.

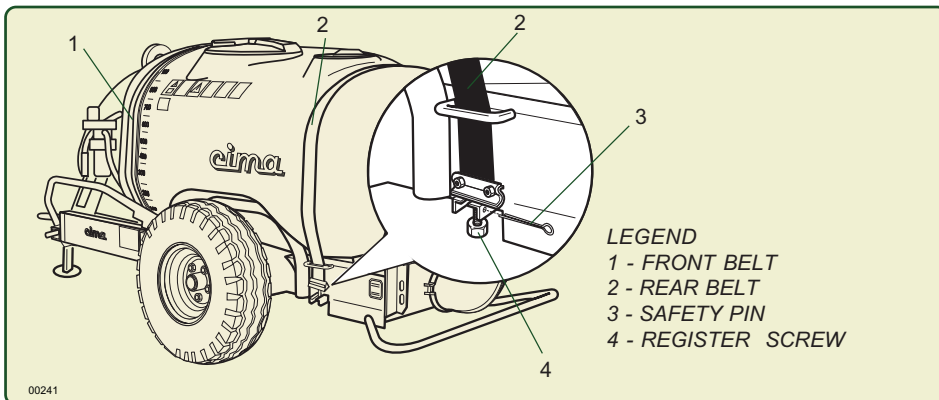

### Versions with additional agitation pump

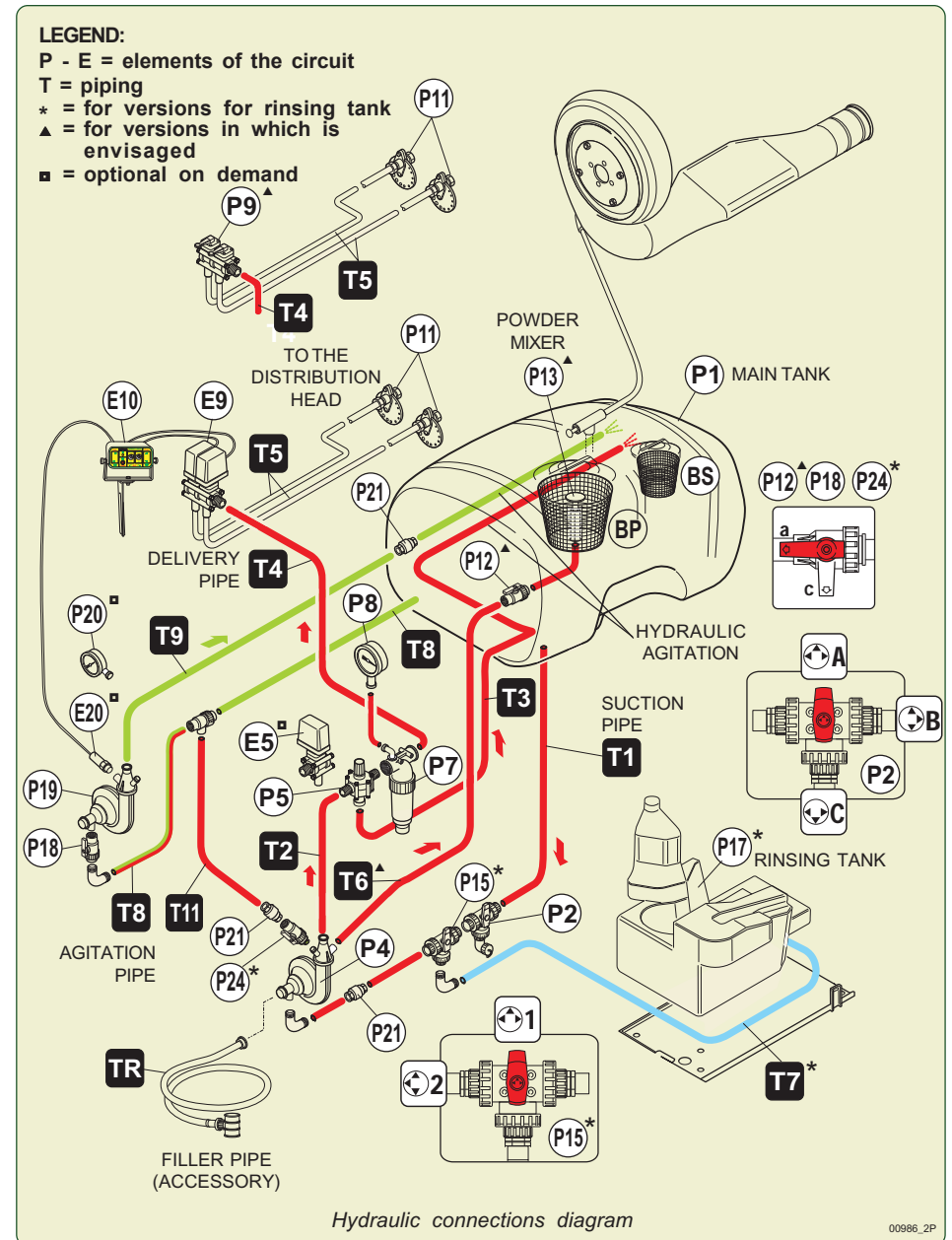

E.P.A. (Delivery Proportional Advancement) versions

**LEGEND:**  
 P - E = elements of the circuit  
 T = piping  
 \* = For versions in which this is envisaged

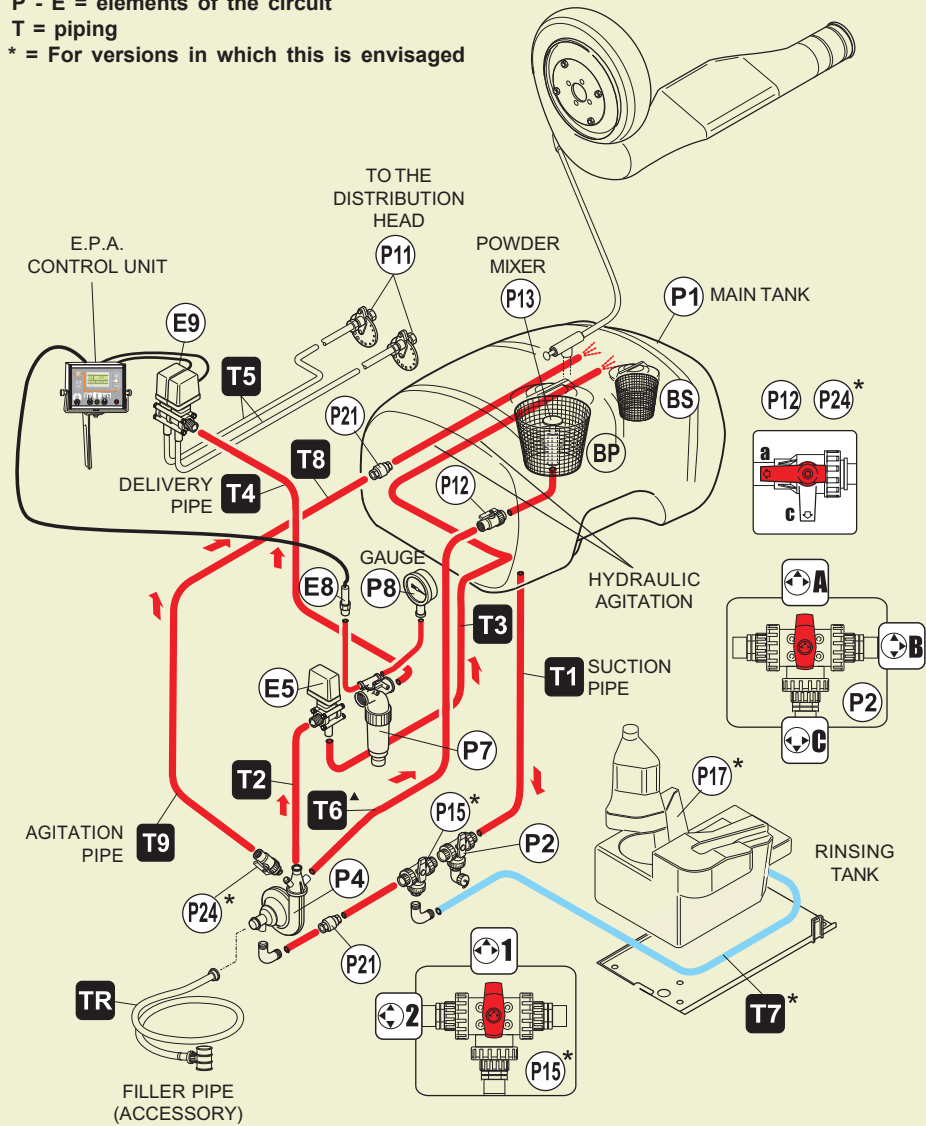

Hydraulic connections diagram

00962\_1P

- Remove the two collar (5) fastening bolts, fixing the fan casing to the rear cover.
- Extract the fan casing (2).



The impeller hasn't to be disassembled.

- Clean the impeller, by avoiding to use high pressure water jets: they can cause infiltrations into the fan shaft support and consequently damage the bearings.
- Mount back the casing (2), by paying a particular attention to get it perfectly coupled with the rear cover.
- Fasten the fan casing, with the collar (5), to the rear cover and with the collar (1) to the connection tunnel of the spray-head.



Carefully tighten all the fastening collars' bolts.

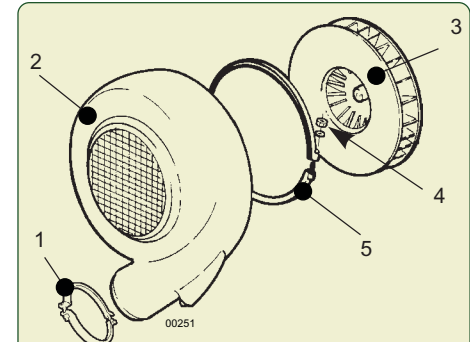

**LEGEND**  
 1. UNION FASTENING COLLAR  
 2. FAN CASING  
 3. IMPELLER  
 4. SCREW NUT  
 5. FAN CASING FASTENING COLLAR

13.6 - FAN BELT TENSIONER

Check length "L" of the spring (refer to Picture): it should be in tension between 9 and 12 cm.

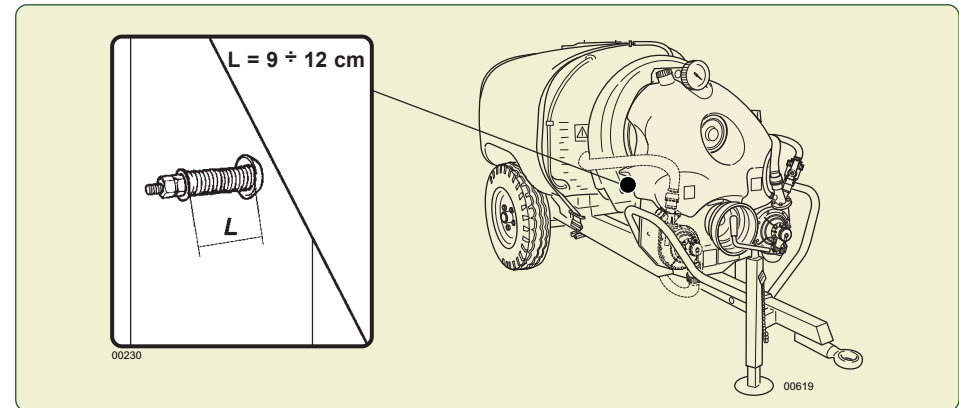

If the fan control belt has to be replaced, the correct tensioning of the same one (spring length) has to be OBLIGATORILY checked after the first and after the second operation hour.  
 If the value measured exceeds 12 cm, tighten the belt tightener screw, up to get the minimum length (9 cm).

The belt setting will take place within the first 2+3 operating hours; when that time has elapsed, verify the spring length, according with the time intervals (periodicity) indicated in the "Maintenance operations' table".

### 13.3 - FAN SHAFT SUPPORT OIL REPLACEMENT



Let the fan support oil replacement intervention be carried out at a C.I.M.A. customers' service centre, or observe the regulations in force for the disposal of the used oil.

1. Unscrew and remove the oil filling plug with the dipstick.
2. Remove the oil drain plug and let the oil completely flow out from the fan shaft support.
3. Check the oil drain plug and the relevant seal for integrity, replace them, if necessary, and close again the oil drain plug.
4. Through the filling pipe, pour a SAE 90 oil proper quantity, up to reach the MAX notch on the dipstick:  
- about 0,19 kg for the 45 model  
- about 0,24 kg for the 50-55 model.
5. Position again the plug with the dipstick and close the oil filling pipe.

### 13.4 - CLEANING OF FILTER'S CARTRIDGE

1. Set the lever of 3-way tap (P2) to the "B" position.
2. Completely close the pressure regulator, by turning clockwise the handle of the manual regulator (P5) or by turning the pressure up (keep the joystick on "+" for about 15 seconds) if the atomizer is provided with electric regulator (E5).
3. Position the switches of the control electric switchboard (E10) on "OFF" or close the manual distributor's taps (P9).
4. Undo the thumb screw and remove the body of the filter.
5. Extract the cartridge: clean the grill and the retaining O.Ring.
6. Reassemble the cartridge and secure the lid with the thumb screw. **Pay attention to the O-Ring of the lower body during the assembly:** the incorrect sealing of the filter will jeopardise the proper operation of the sprayer and cause loss of the mixture.

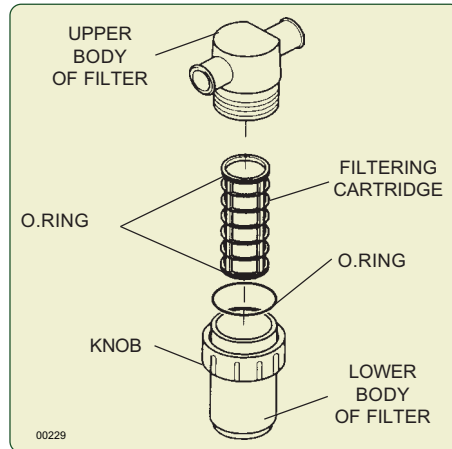

### 13.5 - CLEANING OF THE FAN



It is advisable for the cleaning of the fan to be carried out at a C.I.M.A service point. Dirt accumulation or incrustations can unbalance the fan, inducing vibrations that could cause breakage

1. Remove the distribution device (head).
2. Remove the fastening collar (1), fixing the fan casing outlet orifice to the connection tunnel of the spray-head.
3. Remove the two collar (5) fastening bolts, fixing the fan casing to the rear cover.

### E.P.A. versions with additional agitation pump

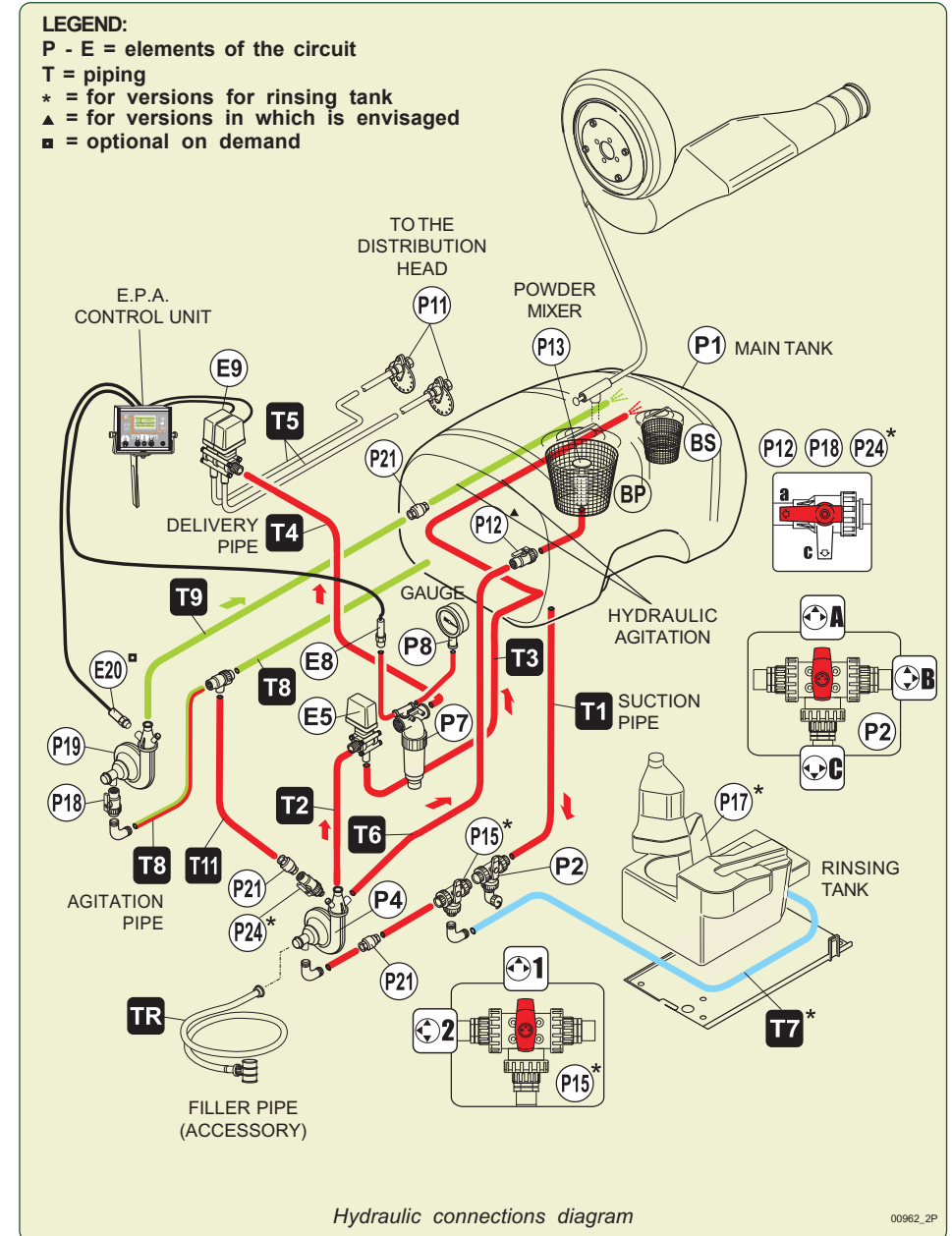

## P1. MAIN TANK

Polyethylene tanks of 600, 800, 1000, 1500 and 2000 litre capacity

Each tank is made up of:

- tank main filler, (BP) with a 355 mm. diam.hinged cover (on 600 ltr. tank) or with a 400 mm diam.hinged cover (on 800, 1000, 1500 and 2000 ltr.tank), with breather pipe; Plastic cup-like filter: 302 mm external diameter, height 254 mm, powder mixing device (for versions in which this envisaged);
- supplementary tank filler with 250 mm diameter screw-type lid, for filling with clear water and plastic cup-like filter: external diameter 204 mm, height 240 mm;
- transparent level indicator external pipe with graduated scale, (One on the left-hand side of the tank L1 and one on the front side L2);
- double hydraulic agitation;
- pneumatic agitation;
- piston cock, positioned over the tank and connected through a pipe to the air inlet, which is placed on the fan casing, for opening/closing the pneumatic agitation (only for sprayers with 600, 800 and 1000 litres tanks);
- ball cock, placed on the pipe connecting the air intake, which is positioned on the fan casing, with the coupling in the tank upper section, for opening/closing the pneumatic agitation (only for sprayers with 1500 and 2000 litres tanks).

## P22. ADDITIONAL HAND-WASHING TANK

30-litre polyethylene tank, with external tap.

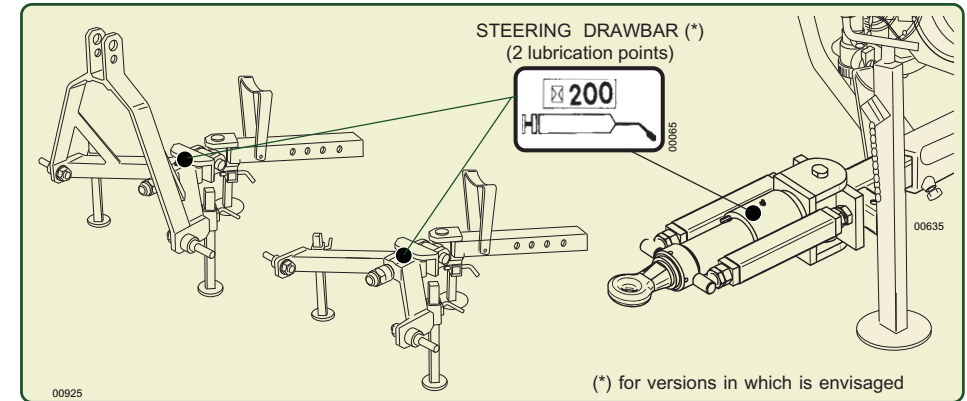
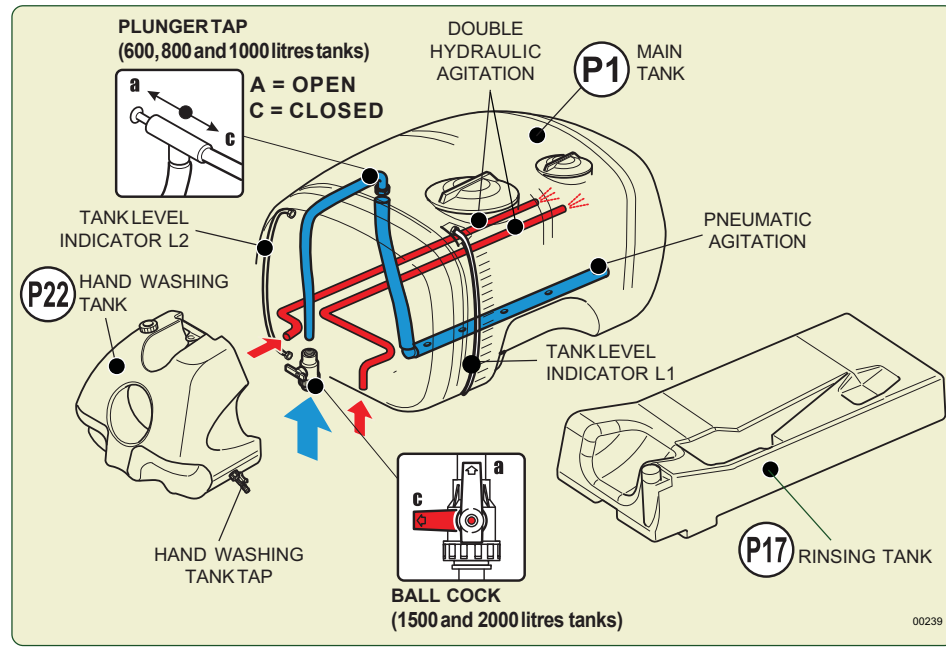

## 13.2 - FAN SHAFT SUPPORT OIL LEVEL CHECK

1. Unscrew and remove the oil filling plug with the dipstick.
2. Clean the dipstick and introduce it again.
3. Extract the dipstick and check the oil level, which has to be between the two minimum and maximum level notches of the dipstick itself.  
Should it be necessary to top up the level, add some SAE 90 oil, up to reach the dipstick upper notch (MAX).
4. Introduce and screw the oil filling plug with the dipstick.

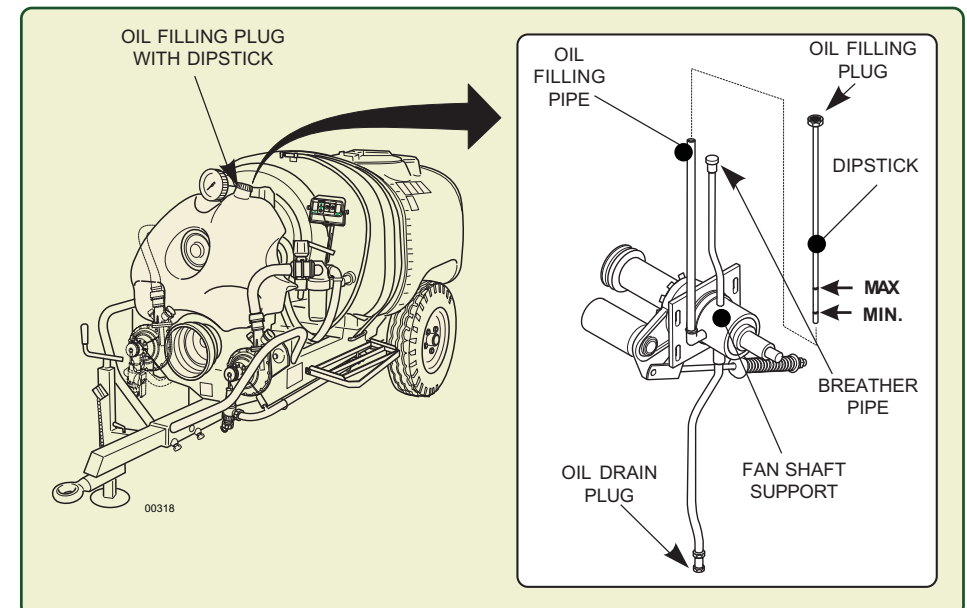





ALL OPERATIONS MUST BE CARRIED OUT WITH THE ENGINE SWITCHED OFF AND WITH THE IGNITION KEY REMOVED FROM THE CONTROL PANEL.



The machine has to be periodically revised according to the country rules. The inspections and the release of the certificate have to be made by special provided structure of the country where the machine is used.

### 13.1 - LUBRICATION

Maintenance Point	Action	Consumption material	Periodicity
Fan shaft belt support	Check Oil	Oil SAE 90	8 hours
Fan belt-tensioner support	Greasing	Grease Tipo EP Class NLGI 2	200 hours
Free wheel	Greasing	Grease Tipo EP Class NLGI 2	200 hours
Wheel hubs	Greasing	Grease Tipo EP Class NLGI 2	200 hours
Support foot	Greasing	Grease Tipo EP Class NLGI 2	200 hours
Steering drawbar	Greasing	Grease Tipo EP Class NLGI 2	200 hours
Fan shaft bearings support	Change oil	Oil SAE 90	1 year

BLITZ07



Carefully clean the greasing nipples and the oil filler in order to avoid that, during lubrication, dirt might be introduced. In the case of intensive use of the machine, reduce the lubrication intervals.

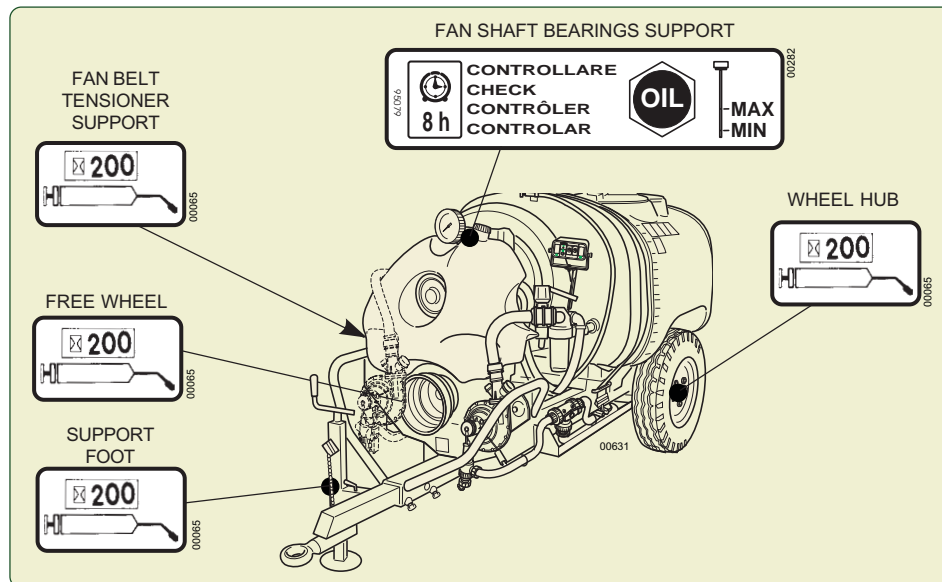

### P2. 3-WAY LEVER TAP A WITH DISCHARGE FITTING

Positioned on the pipe (T1), between the tank (P1) and the pump (P4), it is equipped with a closing plug of the discharge fitting, with the relevant safety chain.

The 3-way lever (P2) can be positioned as here following specified:

#### A - Treatment

The liquid gets out from the tank (P1) and is sucked by the pump (P4); this is the **NORMAL** operating position, which is used in order to carry out the treatment and/or to keep the mixing on. The discharge fitting is **closed**.

#### B - Filling

This position is used in order to fill the tank through the especially foreseen pipe, to be applied to the fitting on the pump (P4). It is closed the suction pump from the tank, the drain plug must be properly tightened and should NOT be removed. When the cock is on that position, it is moreover possible to remove the pump (P4), also when the tank is loaded.

#### C - Drainage

In this position, it is possible to empty: the tank (P1), the pump (P4) and all the pipes of the hydraulic circuit.

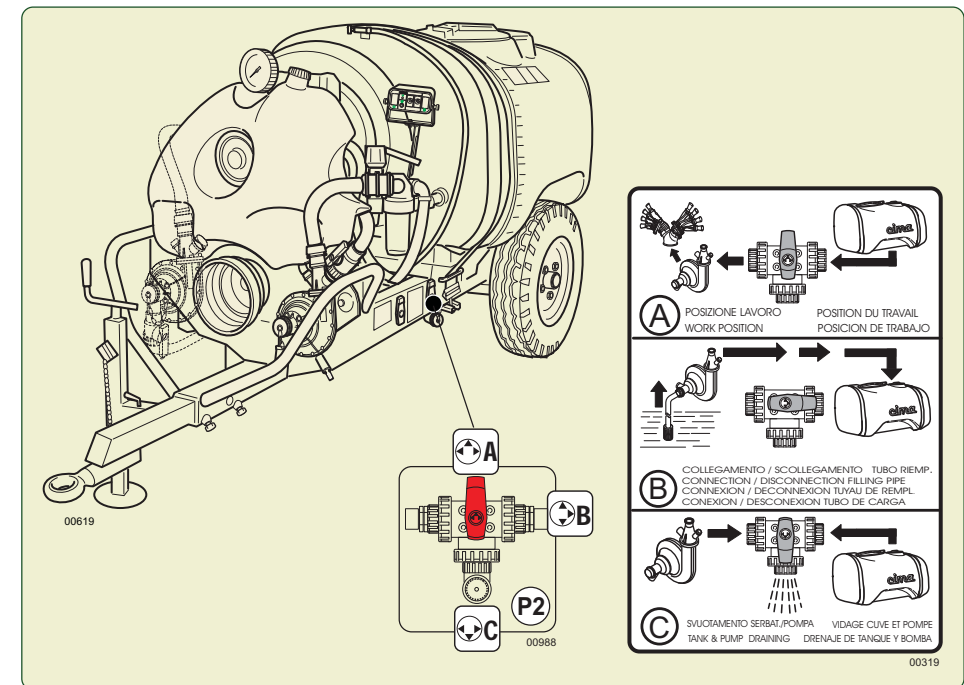

## P4. CENTRIFUGAL PUMP

Fastened on the unit left front section, it is connected with the 3-way cock (P2) and with the pressure regulator (P5). The pump is provided by the suction side of a filter to prevent the accidental entry of foreign bodies in the pump body, such a possibility does not constitute a hazard and can only cause damage to the impeller shown by a drop in pressure reported by gauge

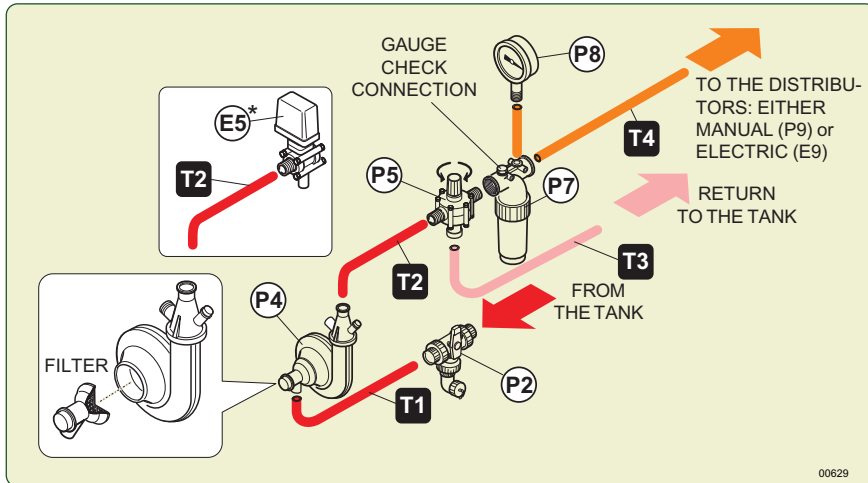

### THE PUMP MUST NEVER RUN DRY

The water must be always in the pump : **ALWAYS** check this point carefully at the start up and during the functioning.

To avoid any damage to the pump :

- At the first filling and at every next filling after the hydraulic circuit draining, fill the tank with an appropriate quantity of water to fill the pump completely.
- In order to control that the pump is not running dry, **AFTER** engaging the PTO, check that the pressure gauge (P8) shows an operating pressure value above 0 (zero).

## P5. MANUAL PRESSURE REGULATOR

It is connected to the delivery filter (P7) and, through pipe (T3), to the tank (P1). It regulates the operating pressure, by controlling the return flow to the tank.

- **By closing it: it REDUCES the return flow** to the tank and therefore, the agitation of the mixture, and increases the operating pressure and the capacity flow to the head (rotate the handle clockwise).
- **By opening it: it INCREASES the return flow** to the tank and therefore, the agitation of the mixture, while reducing the operating pressure and capacity flow to the head (rotate the handle anti-clockwise).



### THE FOLLOWING ACTIONS ARE NOT ALLOWED:

- Transporting or lifting the sprayer with residual quantities of mixture in the tank for purposes differing from its destined usage.
- The transporting of people, animals or things.
- The trailing of vehicles or equipment.



Road transport must take place in the complete observance of road regulations in force in the Country where the machine is used. The operator is responsible for possible defaults due to the non observance of said regulations.

### • Lifting and transport of the sprayer



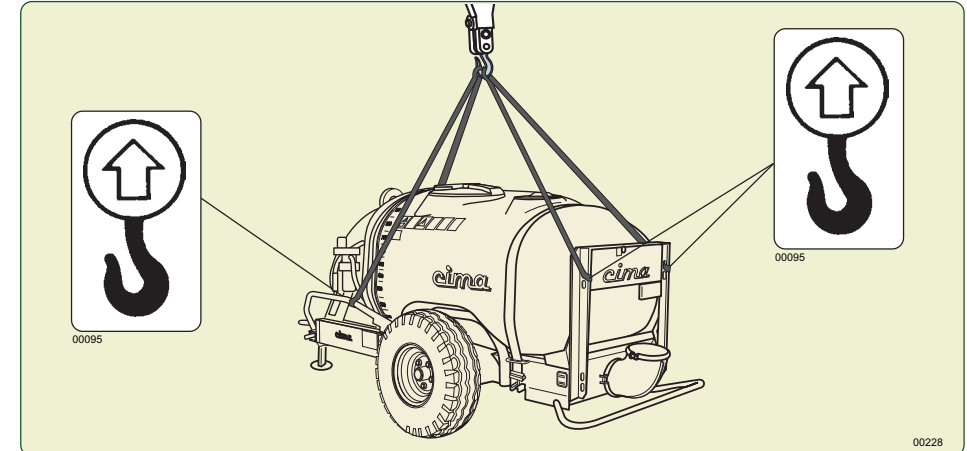

Before carrying out any operation it is essential to verify that no mixture residues are left in the tank.

1. Check that the lifting devices (bands, ropes, etc.) are adequate for the weight to be lifted (machine – distribution devices - accessories).
2. Hook the machine through the specific support point indicated by the specific decal on the frame, checking all the parts involved in the operation.
3. Lift the machine, verifying that it is properly balanced.



4. Position the sprayer on the transporting vehicle in perfectly stable conditions.
5. Lock the sprayer with the wedges locking wheel.
6. During transport the machine must be immobilised and fastened to the carrier by way of suitable strapping.

# 11 TANK AND HYDRAULIC CIRCUIT DRAINING 11

-   - Stop the grape harvester and remove the key from the control panel.
- Wear suitable protective clothing and accessories in order to avoid contamination by contact or inhalation of the mixture.
- Carry out the discharging in a suitable and properly geared area for the collection of the washing liquid.

This operation has to be carried out with the lever tap (P2):

1. Position the lever of the 3-way cock (P2) to "A - WORK POSITION" (draining closed).
2. Unscrew the drainage plug.
3. Turn the lever to position "C - DRAINING" (draining open).
4. When the draining is completed, position again the lever tap (P2) to "1" (agitation), and screw again the chain plug.

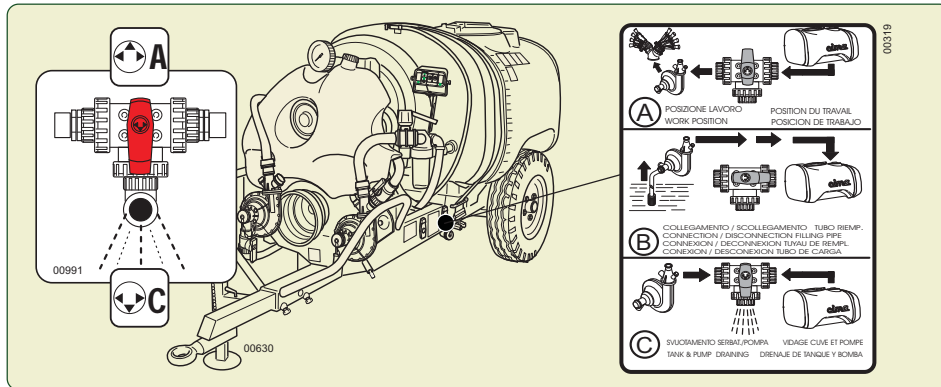

For the version where foreseen:

1. To make the discharge of the circuit of additional agitation pump (P19) close the cock (P18), position "2".
2. Unscrew and remove the drain plug with chain from pump (P19) to drain the pipes.
3. Complete emptying, replace drain plug and return the lever cock (P18) to "1".

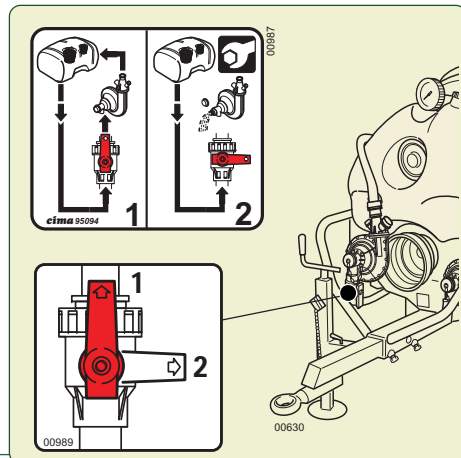

# E5. PRESSURE CONTROL ELECTRO-VALVE (for the version where foreseen)

It is connected to the delivery filter (P6) and to the tank (P1), through the pipe (T3). It adjusts the operating pressure checking the backflow into the tank.

- Moving the joystick downwards (-) on the electrical control gearbox, the electrovalve open: in the tank both the backflow and the agitation of the mixture increase while the values of the working pressure and the delivery to the sprayhead decrease..
- Moving the joystick upwards (+) on the electrical control gearbox, the electrovalve closes: in the tank both the backflow and the agitation decrease while the values of the working pressure and the delivery to the sprayhead increase.

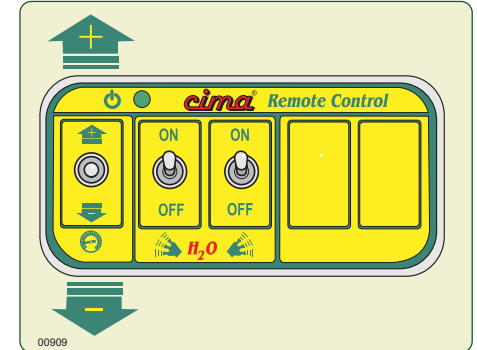

In the E.P.A. versions, the pressure regulation is **automatically** controlled by the electronic control unit (see specific manual)..

# P7. P7. FILTER

It is connected to pressure regulator (P5) and, through pipe (T4), to the distributor (E9/P9). The filter has a filtering capacity of 250 l/min., with a 50 mesh cartridge. The dirty cartridge causes the operating pressure chute. This inconvenient is signalled by the pressure gauge. Mounted on the feeding pipe, it only filters the delivery flow to the heads, by sensibly reducing the possibility for the cartridge to get obstructed. On the body of the filter there is an attack, with internal thread 1/4", to make a functional test of the gauge (P8).

# P8. GAUGE

Glycerine-dipped, with dial from 0 to 6 Kg/cm<sup>2</sup> (atmosphere) – adjustments scale of 1/10 of atmosphere, 100 mm diameter, class 1,6%; it is connected to filter (P7).

-  Set the working pressure keeping the E9 (or P9) distributors opened.



# E8. TRANSDUCER OF THE DELIVERY PRESSURE

(for the version where foreseen)

In the E.P.A. versions, the pressure transducer is connected to the delivery control computer. (see the specific manual).

## E10. CONTROL UNIT

It is electrically connected to the distributor with 2 motorised solenoid valves (E9) and to the main socket of the tractor (Lighter tap).

The 2 lever switches, controlling the solenoid valves (E9), have to be set to "ON" for opening and to "OFF" for closing. The control unit is equipped with a bayonet support to be inserted in the bracket provided. This must be mounted on the tractor, within the driver's reach. When the machine isn't hitched to the tractor, it must be placed in the position foreseen on the forward part of the machine frame.

In the versions with the additional agitation pump, the gearbox is equipped with a RED warning light indicating an insufficient pressure : in the versions with the pressure control electrovalve, the gearbox is equipped with a joystick for moving the electrovalve and for adjusting the delivery pressure control.

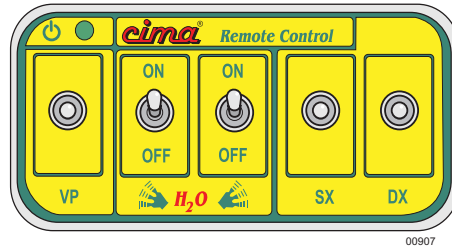

## E9. ELECTRICAL DISTRIBUTOR WITH TWO SOLENOID VALVES

It is connected with the feeding pipe (T4), the distribution pipes (T5) and the electrical unit (E10), which is fastened on the tractor. The solenoid valves open and close themselves, according with the action carried out on the electrical control unit switches.

In the E.P.A. versions, the controls of the cross section solenoid valves are situated on the electronic control unit (see specific manual).

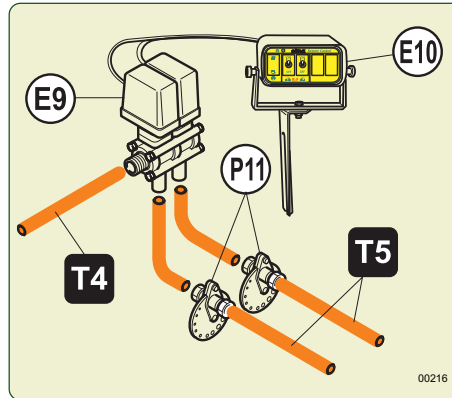

## P9. MANUAL DISTRIBUTOR WITH 2 LEVER-OPERATED TAPS

(for versions in which this envisaged)

It connects the feeding pipe (T4) to the distribution piping (T5). It remote-controls the closing and opening of the pulverising. The mount bracket, supplied with the machine, must be secured to the tractor within the driver's reach. When the machine is not hitched to the tractor, it must be placed on the forward part of the sprayer's frame.

Each tap permits the spraying from a single side of the head: to the right and to the left respectively. They are **open** when the levers are set in the **vertical** position.

They are **closed** when the levers are **horizontal**.

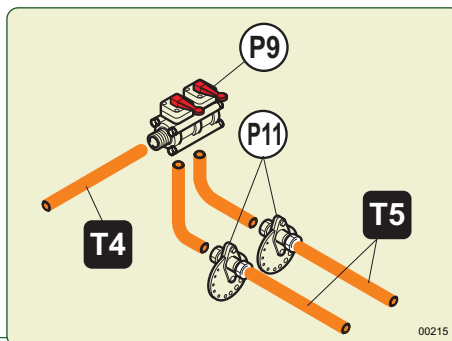

## 10.5.2 - End of seasonal cycle

• **The operator must:**

- Take the utmost care in carrying out the operations envisaged at the end of the daily treatments: the cleaning of the hydraulic circuit must be done at least twice. Check that no product residues are left in any part of the circuit.
- Execute the necessary maintenance and lubrication operations (see paragraph 15.9), then let the atomizer operate for some minutes.



### THE PUMP HAS NEVER RUN DRY

- Completely drain the hydraulic circuit, paying a special attention to the centrifugal pump; in order to completely drain the pump, remove the draining plug, which is mounted on the pump itself.

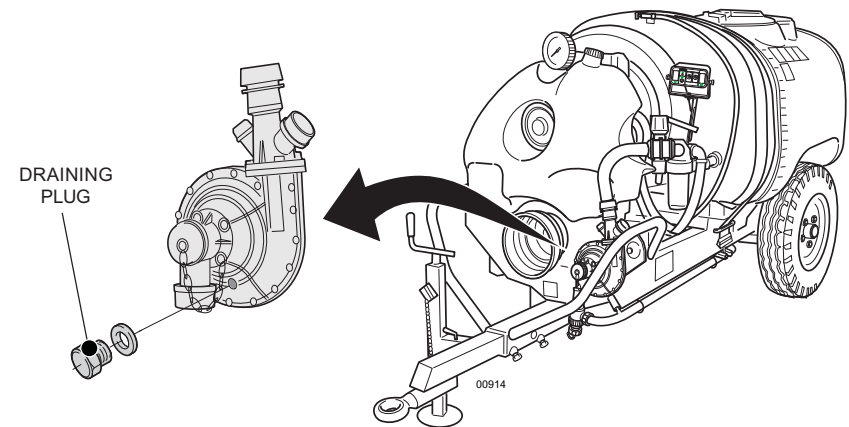

### Avoid using anti-freeze solutions.

- Check the proper operation of all parts and of the machine structure. In case of faults being detected, request the intervention of one of our service points.
- Keep the machine on a plane surface with a suitable consistency, in a well ventilated place, sheltered from rain, icing and direct sun rays.



### The machine must be stored in a secure or closed place, so as to prevent access to unauthorized personnel.

Or

- 11b. Spraying the rinsing water in the previously treated area. Discharge the remaining water of the tank and pipes, gathering it in a proper container to waste it following the country rules or use it again, putting in the tank, for a next treatment if thi will be suitable with the product tu use.

**if the machine HAS NOT a spray-line rinsing tank:**

- a. Put about 15 lt.of clean water in the tank and spraying it in the already treated area.  
 b. Wash the tank:  
 1. Put in the tank a quantity of clean water equal to almost 10% of tank capacity, with the agitator while running.  
 2a. Discharge the rinsing water in a proper area provided with a drain basin for the collection and take care of waste according to the country rules.

Or

- 2b. Spraying the rinsing water in the already treated area. Then, discharge the remainig water of the tank and pipes gathering it in a proper container to waste it following the rules or use it again, putting it again in the tank, for a next treatment, if this will be suitable with the product to use.  
 c. Wash the machine externally:



**To wash it externally DO NOT USE high pressure washer (MAX 5 bar).**

When each treatment has finished, it must wash the sprayer outside, in a proper area provided with a drain basin for collection and subsequently treatment of rinsing water. These area are forbidden to unauthorized personnel, children and pets. To outside sprayer rinsing, it is possible to use proper cleaning products and biodegradable to make the operation easier. When the rinsing is finished, switch on the fan for few second (about 10) to remove residual water on carter and pipes which lead the flow to the sprayhead.

- d. Check the efficiency of the distribution device (head) and the cleaning of the pulverising points (diffusers), possibly replacing them if found to be damaged.  
 e. Clean out the filter cartridge.  
 f. Keep the machine in a ventilated place, sheltered from rain or sun: sunrays are the worst enemies of plastic and rubber parts.



**The machine must be stored in a secure or closed place, so as to prevent access to unauthorized personnel.**

### P11. CALIBRATION DISC (Patent N° 23238)

It selects the flow rates necessary to the treatment and is mounted on the distribution devices. It is made up of 2 flanges, held in position by two butterfly nuts, locking a disc with calibrated holes numbered from 1 to 15. A groove on the edge of the disc allows the exact positioning of the hole to be utilised. Its number must appear in the flange's semi-circular seat. The rotation of the disc is obtained by loosening the butterfly nuts by a few turns. After the operation is done, screw back carefully.



**Any faulty sealing condition of the hydraulic circuit causes an intermittent issuing of the sprayed material. It is necessary to carefully check the efficiency of the sealers and clamps, the tightening of the ring nuts and fittings and the good working condition of the piping.**

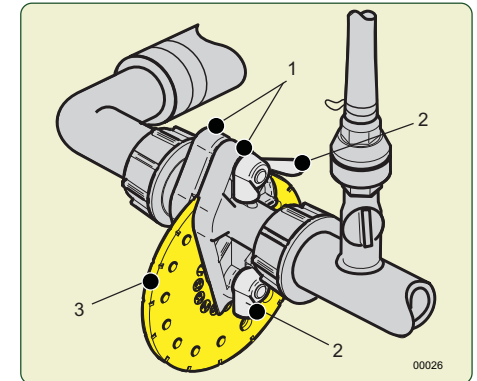

LEGEND

- 1 - UNION FLANGES  
 2 - LOCKING NUT  
 3 - ROTATING DISC WITH CALIBRATED HOLES

### P19. ADDITIONAL AGITATION PUMP (For versions in which this envisaged)

Fastened on the machine right front side, it is connected to the tank (P1) through the pipes (T8 - suction) and (T11 - delivery).



**THE PUMP MUST NEVER RUN DRY : ALWAYS check this point carefully at the start up and during the functioning.**

**To avoid any damage to the pump:**

- At the first filling and at every next filling after the hydraulic circuit draining, fill the tank with an appropriate quantity of water to fill the pump completely.
- The feeding of the 2nd pump is "forced" in any use condition, even when the sprayer is working on sloping grounds and/or with the tank almost empty : in this way the pump does not run dry.

The pressure sensor (E20) with the low pressure warning light placed on the electrical control box (E10), or the gauge (P20) can be installed.

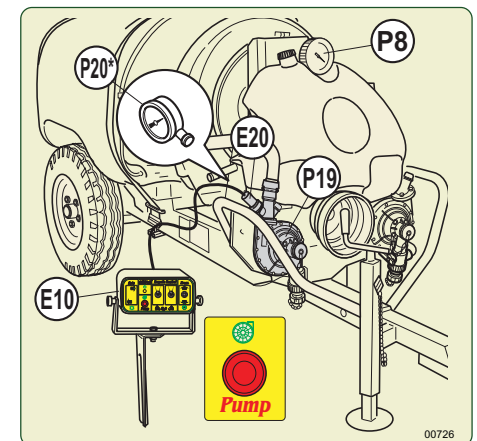

## E20. PRESSURE SENSOR OF THE ADDITIONAL AGITATION PUMP

(On demand)

The sensor of the pressure pump, placed on the delivery cone of the additional pump sends the pump pressure control signal to the control gearbox.



**CAUTION:** at starting the RED low pressure warning light is "ON" ( CHECK LAMP function ) and it switches "OFF" while engaging the PTO. In case this warning light is still "ON" during the working operation or at the PTO engagement, STOP the PTO and check the liquid level in the main tank. In the E.P.A. versions, the warning lamp is situated on the electronic control unit (see specific manual).



The pump pressure sensor is protected by a waterproof rubber cap. In case of malfunctioning due to a breaking or a damage occurred to the rubber cap, replace it immediately

## P18. ADDITIONAL PUMP 3-WAY LEVER TAP

(For versions in which is envisaged)

Positioned on the pipe (T7), between the centrifugal pump (P19) and the main tank (P1), it is equipped with a closing plug of the discharge fitting, with the relevant safety chain.

The control lever (P18) can be set to the following positions:

### 1 - Agitation

The liquid gets out from the tank (P1) and is sucked by the pump (P19), then, through the delivery pipe (T7) it returns to the tank, so provoking a further hydraulic agitation of the mixture. **The drainage is closed.**

### 1 - Agitation/mixing (E.P.A. versions only)

The liquid gets out from tank (P1) and is sucked by pump (P19), and, through the agitation/mixing pipe (T8), gets back to the tank through cock (P12), which allows either the product mixing (pos. "1") or the hydraulic agitation of the mixture (pos. "2"). **Outlet is closed.**

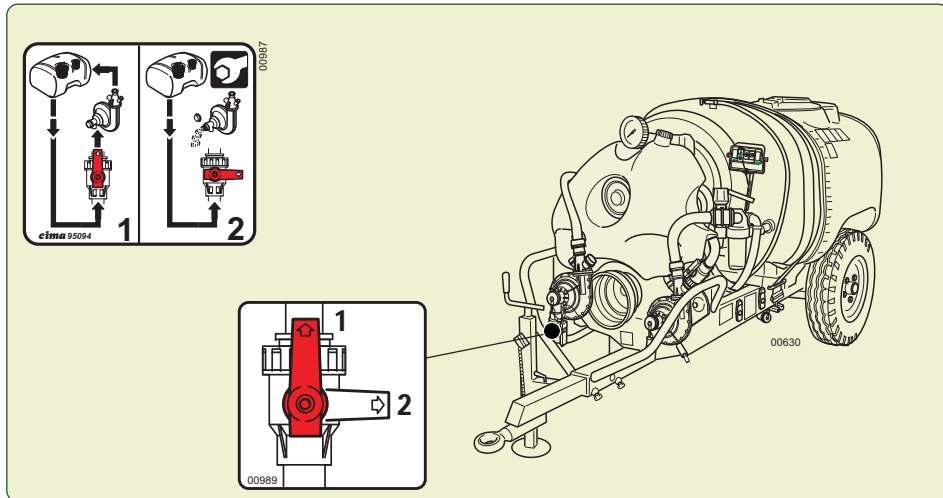

## 10.5 - END OF TREATMENT - STORAGE

### 10.5.1 - Daily

The operator must:

**if the machine is equipped with unit-washing tank:**

- Carry out the hydraulic circuit washing process (see paragraph 10.4) spraying on the piece of ground treated yet. Attention: to make to spray the sprayer for around 5 sec..
- Wash the inside of the tank:
  - Disengage the fan (for the version where foreseen): see point 8.1.a.
  - Close the taps of the 2-way distributor:
    - if electrical, position the latch switches (E10) on "OFF"
    - if manual (P9), set the levers in the horizontal position;
  - Close the pressure regulator completely, by rotating the hand regulator (P5) handle clockwise or by turning the pressure up (keep the joystick on "+" for about 15 seconds) for the versions with electrical pressure regulator (E5)
  - Close the faucet (P24), lever on "c".
  - Put the cock (P15), in to position "2" (washing);
  - Engage the drive outlet (PTO) and take it to a speed of 540 RPM



**Use ONLY the PTO at 540 rpm. Engage the PTO with the engine of the tractor at low speed and with maximum modularity, obtaining soft and progressive graft and avoiding abrupt starts of the cardan shaft.**

- Open the tap (P12), lever on "a".
- Rinse the tank until the water in the spray-line rinsing tank is totally run out.
- Disengage the drive outlet (PTO).
- Close the tap (P12), lever on "c".
- 11a. Discharge the rinsing water in area with a drain basin and arrange the waste following the country rules.

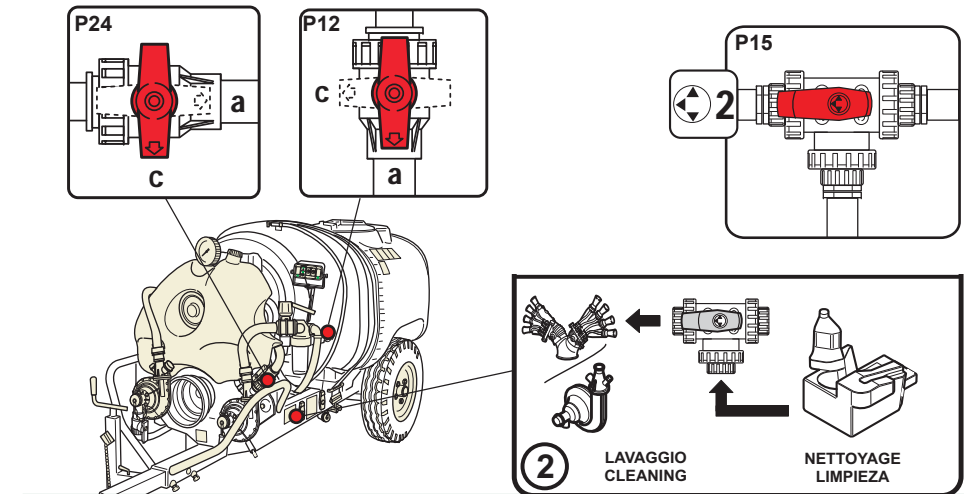

d. Engage the PTO and take it to the correct distribution condition (540 rev/min - see paragraph 4.4.2).



**CAUTION: THE PUMP MUST NEVER RUN DRY.**

e. Open the electrovalves (E9) by taking the switches of the control electric switchboard (E10) on **ON**; make the atomizer work spraying on the piece of ground not treated yet.

**That easy procedure allows to eliminate every fuel mixture residual from all the hydraulic circuit components, so assuring in first place the accurate cleaning and the consequent efficiency of the calibrated holes of the rotary disc regulators.**

f. Disengage the PTO.

g. Close the cock (P15) by taking it to the **1-WORK** position.

h. If before the cock (P24) was closed reopen it to restore the secondary delivery of the pump.

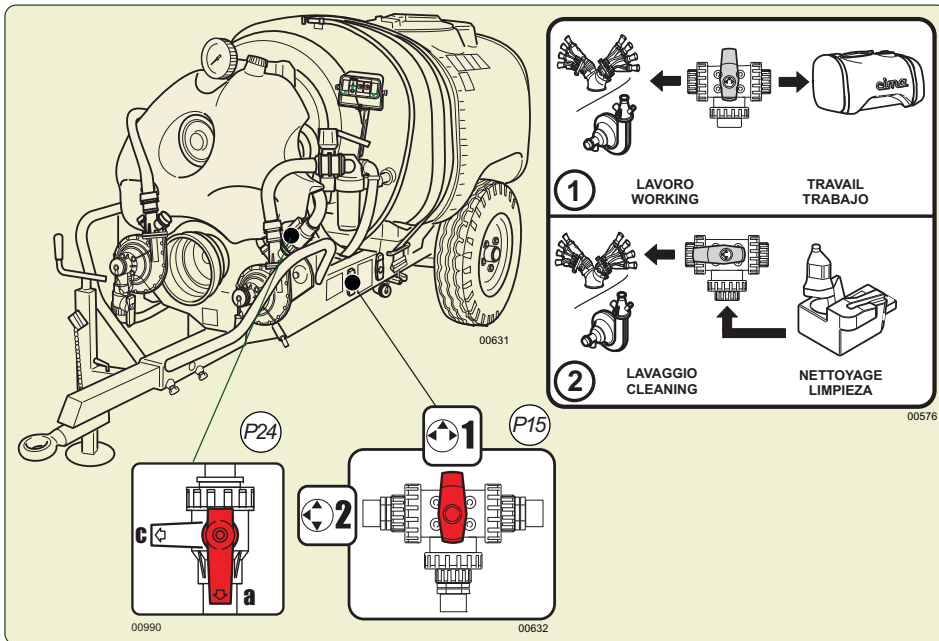

## 2 - Stop

On that position, the suction of the additional pump (P19) is closed to perform maintenance on the pump.

## P12. POWDER MIXER LEVER TAP

(For versions in which his envisaged)

Positioned on the pipe (T6), between the main tank (P1) and the centrifugal pump (P4), it can assume the following positions:

### a - Open

From the centrifugal pump (P4), the liquid is sent to the mixer positioned on the bottom of the cup-like filter of the main filler (BP).

### c - Closed

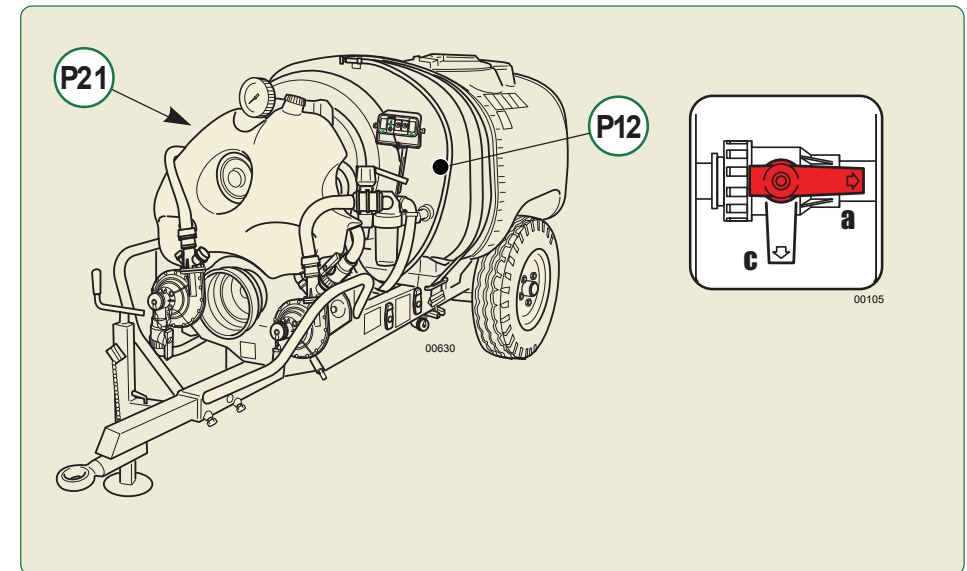

## P21. NON-RETURN VALVE

Located on the suction pump (P4) and piping (T8/T9) of additional agitation to the tank and piping (T11) of force-feeding pump additional agitation (P19) in versions with 2 pumps.



The tap (P18) must be in position "1". The tap (P18) must be turned in position "3" ONLY when it is necessary to remove the pump (P19) with the main tank still containing liquid.

## P24. 2nd DELIVERY OF MAIN PUMP EXCLUSION TAP

(Only for versions with rinsing tank)

The tap is placed on the pipe (T11) of the second outlet of the main pump (P4) to the main tank (P1) or to the additional pump (P19) (for the versions where foreseen). The tap **should be left ALWAYS OPEN** (position "a") during the treatment. The tap must be positioned on "c" (closed) **ONLY** for washing the hydraulic circuit.

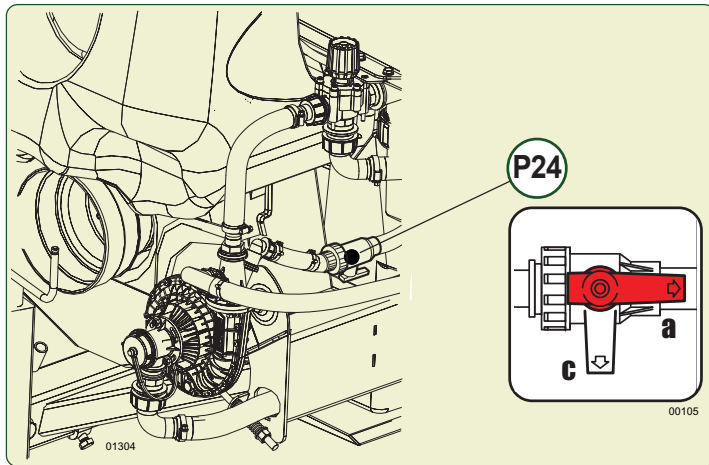

## P17. SPRAY-LINE RINSING TANK (for the version where foreseen)

The polyethylene tank, with a capacity from 60 to 100 ltr. depending on the capacity of the main tank, is equipped with the filler and connection pipes to the hydraulic circuit of the sprayer.



When using the sprayer, keep the spray-line rinsing tank **ALWAYS COMPLETELY FULL** of water: in this way the machine has a better stability.

## P15. UNIT-WASHING 3-WAY LEVER TAP (For versions in which his envisaged)

Positioned on the pipe (T1), between the tank (P1) and the pump (P4), it connects the unit-washing tank (P17) to the main pump (P4) suction.

The 3-way tap (P15) lever can be placed in the following positions:

• The operator must:

- Shake the mixture** in the tank before starting the treatment, re-circulating it completely for as long as it takes to make it homogeneous.
- Check** the orientation of the distributors (hands and/or cannons) of the distribution device (sprayhead) in relation to the dimensions, the shape and the thickness of the vegetation to be treated.
- Continue to shake the mixture until the treatment is resumed should the intervention momentarily be interrupted. If the utilisation is to be deferred, check that the filter cartridge is clean before resuming and **agitate the mixture** that has remained in the tank.
- Ensure that the hand wash supplementary tank is filled with clean water after each filling operation.
- Make use of individual protections identical to those envisaged for the preparation of mixtures if the tractor is not equipped with a pressurised cabin with aeration filters.
- Wash immediately all the elements that might have become contaminated during the treatment, promptly remove the polluted garments and **interrupt the work if these cannot be immediately replaced**.
- Keep to the preliminary operations already indicated (10.1.c), in case of wind conditions prevailing.
- During the breaks, stop the engine, remove the key from the grape harvester's control panel.
- Pay particular attention to the treatment when close to boundaries and in proximity of dwellings, waterways, roads or public-usage paths.

## 10.4 - PROCEDURE TO WASH THE HYDRAULIC CIRCUIT

(head-pump)



Every time it is necessary to suspend the treatment, it is possible to carry out the hydraulic circuit washing process, independently on the loading conditions, i.e., also when the tank is still containing some product mixture, so avoiding any possible clogging and assuring the perfect efficiency of the machine when the treatment is carried on again.

In case of prolonged idle periods, it is recommended to keep the mixture agitated (see Chapter 9).

In order to carry out the hydraulic circuit washing process, follow the instructions here specified:

- Close the pressure regulator completely, by rotating the hand regulator (P5) handle clockwise or by turning the pressure up (keep the joystick on "+" for about 15 seconds) if the atomizer is provided with electric regulator (E5).
- In case the main tank still contains some mixture to spray **CLOSE** the valve (P24), so the water of the spray-line rinsing circuit can not back into the main tank by varying the concentration of the mixture used.



**CAUTION:** in versions with 2 pumps, in case the main tank is empty, **DO NOT CLOSE** the valve (P24) to prevent that the 2nd pump runs dry causing the defect of the mechanical seal.

- Open the cock (P15), by setting it to position "2"; in that way the clean water contained inside the unit-washing tank is sucked by the pump (P4) and gets into the hydraulic circuit.



must be first diluted.

- g. Wash and rinse the just emptied product containers with clean water – collect the washing water and pour it in the tank before carrying out the filling – place the empty packaging in the specific container or in the collection area.
- h. Wash the equipment and tools utilised in the preparation and place them in the chemical products storage area.
- i. **Always** leave the area assigned to the loading and preparation of the mixtures in such condition as to avoid **any** possibility of contamination to persons or animals or of pollution to the environment.
- l. With indelible pen put the name of the product used for the treatment (or of several names) on the decal 10x10 cm and put it on the provided support on the machine.

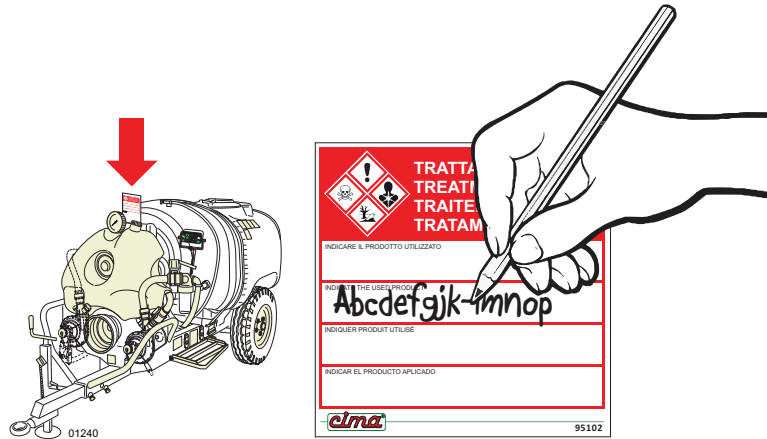

- m. If necessary, mark the field or the area of machine passes in order to provide a guide for the treatment and avoid missing or double-treating coverage areas.



- AT THE END OF THE OPERATIONS NECESSARY FOR CARRYING OUT THE INTERVENTION, THE LOCATION-STORAGE AREAS MUST BE LEFT IN THE CONDITION REQUIRED FOR THE CARRYING OUT OF THEIR PREVENTION AND PROTECTION FUNCTIONS.
- BEFORE STARTING THE GRAPE HARVESTER, KEEP AWAY PERSONS OR ANIMALS AND NEVER LEAVE IT UNATTENDED DURING THE PREPARATION OPERATION.

### 10.3 - THE TREATMENT



IT IS ADVISABLE TO BEGIN TREATMENT AT THE HEADLANDS.



When the treatment is over, or if the same has to be temporarily interrupted, always let the fan still operate for approximately 10 sec after cutting-out the power supply (either manual distributor P9 or electrical distributor E9), in order to fully eliminate the product mixture from the distributing devices, so preventing any possible anomalous dripping from taking place.

#### 1 - Treatment (Work)

The fluid gets out from the tank (P1) and is sucked by the pump (P4); that is the **NORMAL** operation position, which is used in order to carry out the treatment and/or to keep the mixture. **The pipe connection to the unit-washing tank is closed.**

#### 2 - Washing process

The fluid gets out from the unit-washing tank (P17) and is sucked by the pump (P4); that is the position which is used, in order to carry out the hydraulic circuit **WASHING**.



The unit-washing circuit allows to wash the hydraulic circuit (with the exclusion of the tank), in every moment and independently on the tank load conditions, i.e., also with the mixture present inside the tank.

When the tap (P15) is placed to position "2", the clean water for the unit washing is taken from the unit-washing tank (P17), by simultaneously excluding the suction from the main tank. To avoid the clean water returns in the main tank, with a consequent dilution of the mixture, **CLOSE COMPLETELY** the manual regulator (P5), or the electrical one (E5), during the cleaning process.

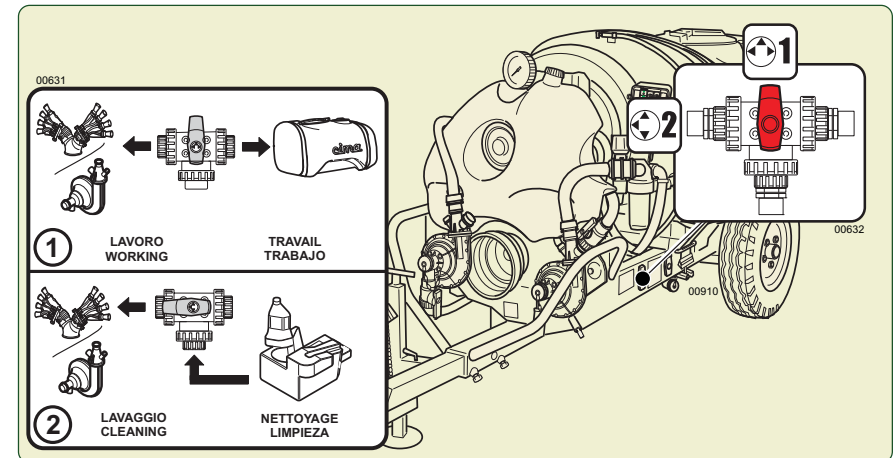

#### P13. POWDER MIXER (for the version where foreseen)

It makes the mixing of the powdery products during the filling of the tank. It is mounted on the basket filter of the main filler (BP) and it is connected to the pump (P4) by the pipe (T6). That device consists of a fine mesh-nylon basket, which is placed inside the tank main filler (BP). The basket is equipped with a mushroom outlet, through which the filling water coming from the pump (P4) streams out. Thanks to that system, the powder products contained inside the basket get more gradually dissolved, and the building of crumbs and thickenings can be avoided.

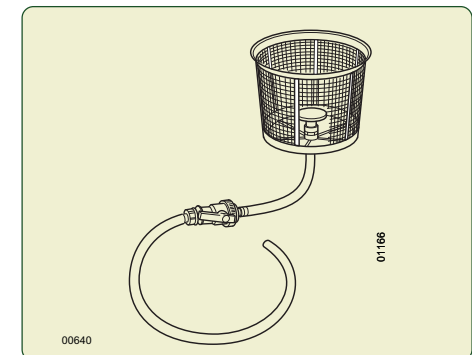

## P26. NIPPLE FOR FLOWMETER CONNECTION

(for the version where foreseen)

The 1" M/M nipple is placed between the delivery pipe for the sprayhead (T4) and the electrical distributor (E9), and it allows to disconnect the pipe and place a flowmeter between the pipe itself and the electrical distributor, to be used for the periodical revising tests.

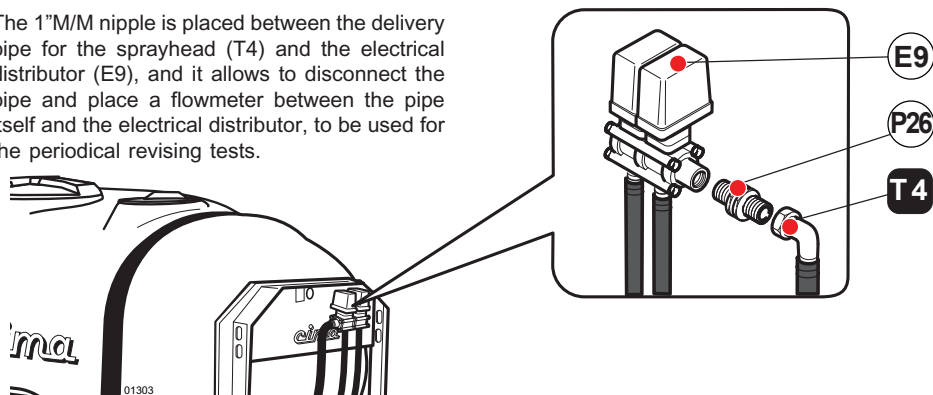

## 4.5 - TECHNICAL DATA

### 4.5.1 - Sprayer dimensions and weights



On the identification plate, the full-load weight (PESO T.) of the machine is indicated, measured **WITHOUT** the distribution device and **WITHOUT** the accessories possibly installed.

In order to calculate the towed weight in operative conditions (at full load), add to the weight indicated on the identification plate (PESO T.), the weight of the distribution device which is used (see "Distribution devices - Use instructions" manual) and the weight of the installed accessories.

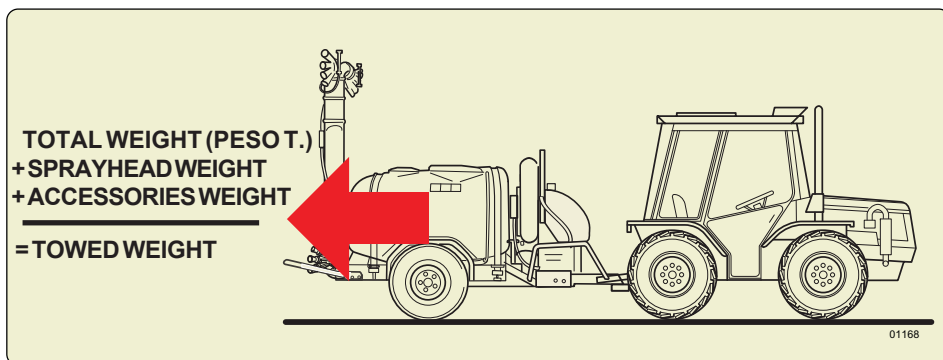

- d. Check that multiple-product mixtures be physically, chemically and biologically compatible amongst themselves; if need be, obtain the necessary information from the products' sales representative.
- e. Carefully calculate the exact quantity of the product necessary for the treatment and establish the volume of water to be used for the intervention.
- f. Check that the product is available in a quantity sufficient to complete the intervention.
- g. Read the product's utilisation instructions carefully, in order to ascertain the usage conditions, the correct dosage and the expiration dates.
- h. Make sure of the parameters necessary to the adjustments of the machine and determine the exact dose of product to be applied to every loading. **Follow the instructions of the publication titled "The low volume - Instructions for sprayers adjustment" as well as those contained in the use and maintenance book-let of the distribution device.**

## 10.2 - PREPARATORY OPERATIONS TO TREATMENT



**THE FILLING MUST BE CARRIED OUT WITH THE MACHINE ON A FLAT SURFACE. BEFORE THE OPERATION, IN THE ALLOCATED AREA, THE DOSES OR MIXTURES TO BE POURED IN THE TANK MUST BE MADE READY.**

Before starting the filling cycle, check:

- THE TIGHTENING OF THE RUDDER, AXLE, HUBS AND WHEELS FIXING BOLTS SCREWS;
- TENSION OF MAIN TANK FIXING BELTS;
- TYRESPRESSURE;
- THE LEVEL OF THE OIL OF THE FAN SHAFT SUPPORT;
- THE CLEANING OF THE FILTER CARTRIDGE (P7);
- THE EFFICIENCY OF THE DISTRIBUTION DEVICE (HEAD).
- THE CONDITIONS OF THE TANK LEVEL INDICATOR.

• **The operator must:**

- a. Wear adequate protective clothing and accessories such as overalls, waterproof suits, gloves, glasses and masks to shield him from contamination by inhalation or contact with the products handled.



- Anti-dust masks don't offer any protection against toxic vapours.
- Avoid wearing loose clothes that might entangle with moving parts.

- b. With the parameters defined during the preliminary operations, carry out the adjustments of the sprayer.
- c. Prepare the mixtures in a well ventilated area. When in the open, the presence of wind increases the danger of contamination.
- d. Precisely weigh the previously calculated doses of products to be mixed at every filling operation.
- e. Avoid handling products close to open flames, embers, incandescent bodies or in the presence of flammable substances.
- f. In order to obtain the correct volume dosage of agro-chemicals and fertiliser mixtures, the fertiliser

The **hydraulic** and the **pneumatic** circuits mounted inside the tank, allow to realize a **double agitation system**: with the pump water and with the fan air, **at the same time**. The pneumatic circuit can be excluded, when the products used have a quite strong foaming effect, by closing the pneumatic agitator cock. When that cock is opened again, check that some air outlet holes aren't obstructed.



It is advised however to also use always the pneumatic agitator, adding to the mixture, if necessary, a antifoam product.

This operation is of main importance, in order to get a uniform distribution of the active principle on the whole vegetative surface to be treated. Should the activity need to be interrupted during a treatment with the sprayer, **keep the agitator activated until the treatment is resumed**.



Before starting the treatment, or return to work after a break, it is essential to agitate the mixture in the tank, re-circulating it completely for as long as it takes to make it homogeneous.



The agitation can be carried out with the manual pressure regulator (P5) or electric (E5), in any position. The tap of the pneumatic regulator has to be open.

**THE MIXTURE AGITATION HAS TO BE CARRIED OUT WITH THE POWER TAKEOFF RUNNING AT A RATE OF AT LEAST 500 RPM..**



Before using the atomizer fill the circuit-washer tank (if provided) and the hand-washer tank with clean water.

### 10.1 - PRELIMINARY OPERATIONS TO TREATMENT

- **The operator must:**
  - a. Ascertain that the condition of the crops, the progress of the disease or the need for its prevention actually justify the treatment to be applied.
  - b. Be aware of the meteorological conditions forecast for all the time necessary for carrying out the treatment.
  - c. If possible, avoid carrying out the spraying in strong wind conditions or when one detects that the sprayed mixture disperses away from the target crop (drifting). It is advisable to suspend the treatment when the wind speed exceeds 3 m/s (10 km/hour). Should it be imperative to operate anyway, the following suggestions are made:
    - reduce the distance of the target from the spraying points, even if detrimental to the quality of the spraying
    - increase the dimension of the droplets, suitably adjusting the machine.

		Blitz 45			
		I. 600	I. 800	I. 1000	I. 1000 narrow
	LENGTH	308 cm	335 cm	344 cm	335 cm
	WIDTH	106-132 cm	106-132 cm	138-180 cm	112-138 cm
	EIGHT	130 cm	134 cm	137 cm	137 cm
	TYRES PRESSURE	7.00-12 2,7 atm	7.00-12 2,7 atm	10/80-12 3,1 atm	10/80-12 3,1 atm
	TYRES (optional)	-	10/80-12 (opt.)	-	-
	TYRE PRESSURE	-	3,1 atm	-	-

		Blitz 50			
		I. 800	I. 1000	I. 1000 narrow	I. 1500
	LENGTH	337 cm	357 cm	357 cm	420 cm
	WIDTH	106-132 cm	138-180 cm	112-138 cm	168-210 cm
	HEIGHT	134 cm	137 cm	137 cm	145 cm
	TYRES PRESSURE	7.00-12 2,7 atm	10/80-12 3,1 atm	10/80-12 3,1 atm	10,0/75-15 3,1 atm
	TYRES (optional)	10/80-12 (opt.)	10,0/75-15 (opt.)	10,0/75-15 (opt.)	
	TYRE PRESSURE	3,1 atm	3,1 atm	3,1 atm	

		Blitz 55		
		I. 1000	I. 1500	I. 2000
	LENGTH	362 cm	435 cm	435 cm
	WIDTH	140-185 cm	168-210 cm	175-215 cm
	HEIGHT	142 cm	150 cm	173 cm
	TYRES PRESSURE	10.0/75.15,3 3,1 atm	10.0/75.15,3 3,1 atm	11.5/80.15,3 3,1 atm

### 4.5.2 - Accessories weight

Description	Model	Part/Number	Weight (kg)	
<b>Oversize axle L 1000</b>	Blitz 45/50 lt. 600-800	DIF.AS.45.06.01	2,40	
<b>Oversize axle L 1200</b>	Blitz 45/50 lt. 1000	DIF.AS.45.10.01	2,25	
	Blitz 55 lt. 1000	DIF.AS.55.10.01	2,25	
<b>Oversize axle L 1500</b>	Blitz 55 lt. 1500-2000	DIF.AS.55.15.01		
<b>Pair of wheels 10/80.12</b>	Blitz 45/50 lt. 600/800	DIFF.R.10/80-12	13,80	
<b>Pair of wheels 10.0/75-15.3</b>	Blitz 45/50 lt. 1000	DIFF.R.10,0/75	20,10	
<b>Pair of wheels "Tandem" axle</b>	Blitz 45/50 lt. 600/800	DIFF.RT.T.01	90,00	
	Blitz 45/50 lt. 1000	DIFF.RT.T.02		
	Blitz 45/50 lt. 1500 Blitz 55 lt. 1000	DIFF.RT.T.03		
	Blitz 55 lt. 1500	DIFF.RT.T.04		
	Blitz 55 lt. 2000	DIFF.RT.T.05		
<b>Steering drawbar with trail eye</b> to be used only with the constant velocity cardan shaft	Blitz lt. 600/800/1000	DIF.TIM.STRZ.06 TIM.STRZ.06	40,10	
	Blitz lt. 1500/2000	DIF.TIM.STRZ.07 TIM.STRZ.07	33,55	
<b>2-points steering drawbar</b> to be used only with the constant velocity cardan shaft	Blitz lt. 600/800/1000	DIF.TIM.STRZ.02 TIM.STRZ.02	16,90	
	Blitz lt. 1500/2000	DIF.TIM.STRZ.12 TIM.STRZ.12	14,05	
<b>3-points steering drawbar</b> to be used only with the constant velocity cardan shaft	Blitz lt. 600/800/1000	DIF.TIM.STRZ.03 TIM.STRZ.03	30,60	
	Blitz lt. 1500/2000	DIF.TIM.STRZ.13 TIM.STRZ.13	28,55	
<b>"Piemonte" sloping hubs</b> To be used only with oversize axle	Blitz 45/50 lt. 600-800	DIFF.MOZZI.P.01	4,00	
<b>Spray-line rinsing tank system</b>	da lt. 60	Blitz lt. 600	DIFF.LAV.AT.11	18,70
	da lt. 80	Blitz lt. 800	DIFF.LAV.AT.12	23,00
	da lt. 100	Blitz lt. 1000	DIFF.LAV.AT.13	27,80
	da lt. 100	Blitz lt. 1000 2P	DIFF.LAV.AT2.133	29,00
	da lt. 100	Blitz lt. 1500/2000	DIFF.LAV.AT.14	28,00

TAB. BLITZ.001



Properly tighten the nuts securing the mobile protection cover.

- Start the tractor.
- Engage the Power Takeoff and set it up to a running rate of at least 500 r.p.m., in order to carry out a further agitation.
- Regulate the operating pressure, by acting on the pressure regulator hand regulator (P5) (or electric E5, for versions where provided) with the distributor, electric (E9) or hand (P9), open (DISTRIBUTION).
- CARRY OUT THE TREATMENT (See the paragraph 11.3).

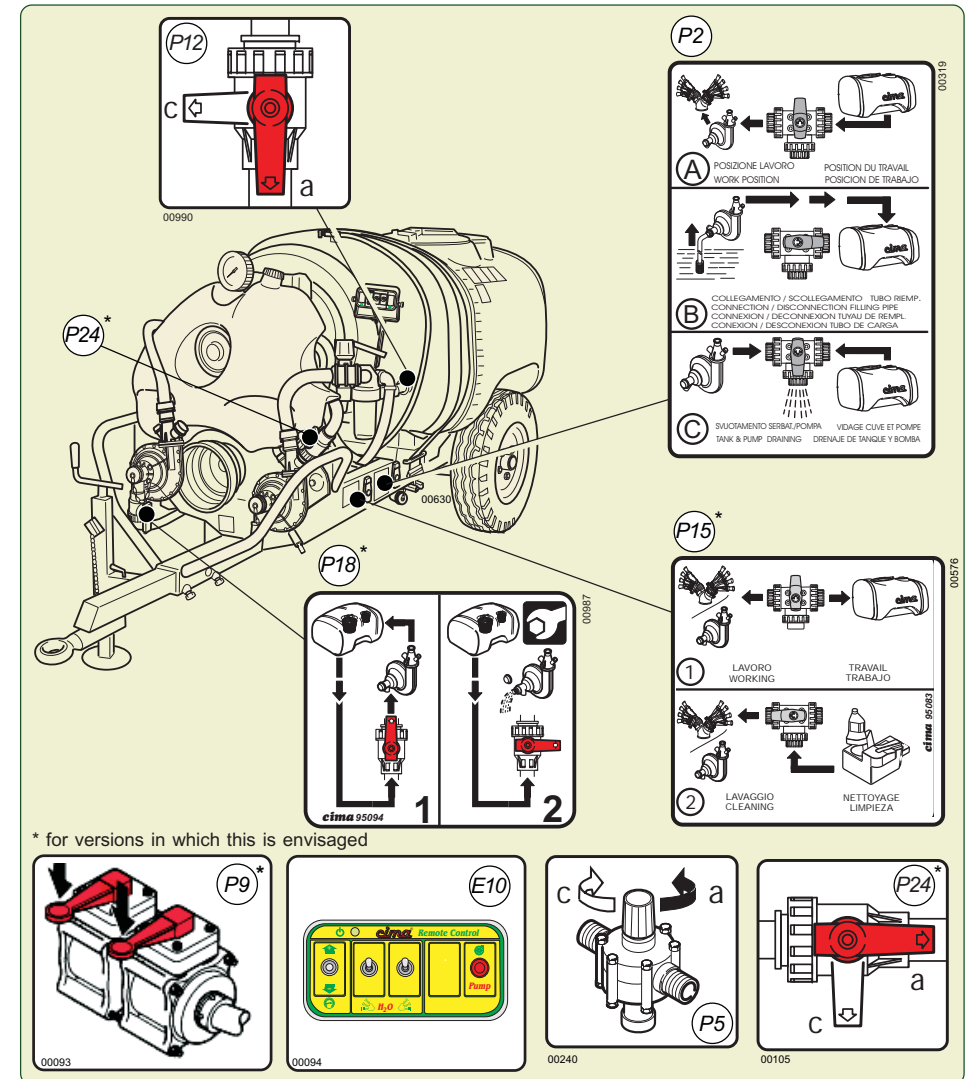

\* for versions in which this is envisaged

7. Close the cock (P12) by positioning the lever on "c". (or position "2" for E.P.A. versions).
8. Completely close the pressure regulator, by turning clockwise the handle of the manual regulator (P5) or by turning the pressure up (keeping the joystick on "+" for about 15 seconds) if the atomizer is provided with electric regulator (E5).
9. Connect the filling pipe to the pump (P4).
10. Immerse the filter with the bottom-drawing valve in the water to be loaded.



**The filter must always be below the level of the water to be loaded. The piping must never be above the pump's suction point and must never be excessively bent in the vertical direction.**

11. Position the lever of the 3-way cock (P2) to "A".
  12. Completely open the pressure regulator (P5), by rotating counterclockwise the handle of the hand regulator (P5) or by setting the pressure at zero (keep the joystick on "-" for about 15 seconds) if the atomizer is provided with electric regulator (E5).
  13. Through the secondary filler (BS), pour into the tank about 15/20 litres of water: that quantity must be enough TO FILL the pipe and TO PRIME the pump (P4).
  14. Start the tractor and engage the PTO; then bring it up to a 500 r.p.m. rotation rate.
  15. When the pump will have started the recycling of the poured water, close the cock (P3), by positioning the lever to "B", in order to start the filling through the return pipe (T3).
- 16a. **WITH MEDICINE MIXTURES OR LIQUID PRODUCTS (WHEN NOT USING THE MIXER)**
- 16a1. Pour the mixture of water and plant protection product previously prepared (or liquid product) foreseen for every loading (and the possible washing water for the medicine packs and for the instruments used for preparing the mixture) into the main filler (BP).
  - 16a2. Close the main filler (BP) of the tank and wait until the filling is completed.
- 16b. **WITH POWDER PRODUCTS, WHEN USING THE MIXER (IF FORESEEN)**
- 16b1. Pour the dose of plant protection product in powder into the cup-like filter of the main filler (BP).
  - 16b2. Close the main filler (BP) of the tank
  - 16b3. Open the cock (P12) by positioning the lever on "a" and wait until the filling is completed.
  - 16b4. Close the cock (P12) by positioning the lever on "c". (or position "2" for E.P.A. versions).
17. Disengage the PTO.
  18. Completely close the pressure regulator (P5), by turning clockwise the handle of the manual regulator (P5) or by setting the pressure at zero (keep the joystick on "+" for about 15 seconds) if the atomizer is provided with electric regulator (E5).
  19. Remove the filling pipes from the pump (P4) and position again the closing plug.
  20. Completely open the pressure regulator (P5), by rotating counterclockwise the handle of the hand regulator (P5) or by setting the pressure at zero (keep the joystick on "-" for about 15 seconds) if the atomizer is provided with electric regulator (E5).
  21. Position the lever of the 3-way cock (P3) to "A".
  22. Engage the Power Takeoff and move to the treatment place, keeping the Power Takeoff running rate at least 500 RPM during all the operations of the treatment.

**IN THE AREA OF THE TREATMENT:**

23. Disengage the power take off (PTO).



**Stop the tractor and remove the key from the control panel.**

25. Make sure that the fan is stopped. Hook the fan to the servo amplifier as indicated at point 8.1, then mount back the release mobile protection cover.

Description	Model	Part/Number	Weight (kg)
<b>Filling pipe with foot valve and filter</b>	Tutti	TUBAZ.RIEMP	2,60
<b>Couple of electrovalves kit</b>	Modelli Blitz	KIT.ELETTR.T	6,00
<b>Electrical swivelling device</b>	Blitz 45/50 D. 175mm	T.GIR.E.175T	11,40
	Blitz 55 D. 250mm	T.GIR.E.250T.01	23,80
<b>Homocinetics cardan shaft</b>	Blitz 45	KHP.040.120G	16,00
	Blitz 50/55	KHP.060.130G	24,00
<b>Extension</b> D.175 x 200 mm	Blitz 45/50	X02.186.000	2,10
<b>Extension</b> D.175 x 400 mm	Blitz 45/50	X02.187.000	3,45
<b>Extension</b> D.175 x 600 mm	Blitz 45/50	X02.188.000	4,75
<b>Extension</b> D.175 x 800 mm	Blitz 45/50	X02.189.000	6,25
<b>Extension</b> D.250 x 200 mm	Blitz 55	X21.100.020	3,40
<b>Extension</b> D.250 x 400 mm	Blitz 55	X21.100.040	5,30
<b>Extension</b> D.250 x 600 mm	Blitz 55	X21.100.060	7,15
<b>Extension</b> D.250 x 800 mm	Blitz 55	X21.100.080	9,00
<b>Collars</b>	Per prolunghe e curve D. 175mm	X05.616.000	0,40
	Per prolunghe e curve D. 250mm	X05.813.000	0,95
<b>Electrical pressure reg.valve with remote control</b>	Modelli Blitz	DIFF.V.R.E.T01	1,70
<b>Electrical command 4 electrovalves</b>	Blitz 45-50	DIFF.CE4.50.T01	
	Blitz 55	DIFF.CE4.55.T01	
<b>Electrical movement Upper diffusers For models with 4 electrovalves</b>	Blitz	S.E.2C.TC.02	
	Blitz 55	S.E.2C.TC.04	
	Blitz	S.E.4C.TC.02	
	Blitz	S.E.4C.TCF02	
	Blitz	S.E.4C.TCI02	
<b>Electrical pressure reg.valve For models with 4 electrovalves or with electr. movement upper diff.</b>	Blitz	S.V.R.E.T01	
<b>Rear lights kit</b>	Blitz	KIT.LP.T.10.02	4,10

Description	Model	Part/Number	Weight (kg)
<b>E.P.A. Delivery Proportional Advancement Kit</b>	Blitz 45/50 lt.800	K.EPA.08.50.T01	
	Blitz 45/50 lt.1000	K.EPA.10.50.T01	
	Blitz 55 lt.1000	K.EPA.10.55.T01	10,00
	Blitz 45/50 lt.1500	K.EPA.15.50.T01	
	Blitz 55 lt.1500/2000	K.EPA.20.55.T01	
<b>4 electrovalves For models with EPA</b>	Blitz 45/50	S.CE4.50.T01E	
	Blitz 55	S.CE4.55.T01E	
<b>Electrical movement upper diffusers For models with EPA</b>	Blitz	S.E.2C.TC.02E	
	Blitz 55	S.E.2C.TC.04E	
	Blitz	S.E.4C.TC.02E	
	Blitz	S.E.4C.TCF02E	
	Blitz	S.E.4C.TCI02E	

TAB\_BLITZ\_003



The accessories and related data listed in this table are up to date at the time of publication of the manual. All products and accessories not included and their updated weights are available on the table (Pesi-Weights.pdf) in the 'restricted area' in the website [www.cima.it](http://www.cima.it), direct link (<http://drawings.cima.it/search?Query=pesi-weights.pdf>).

### 4.5.3 - Centrifugal pump CD32

Model C.I.M.A. CD32 - Grid/filter on suction - Drain plug - Filler for the connection of the filling pipe, with plug with chain.

Activated with trapezoid belt driven by the pulley mounted on the fan shaft.

Technical data printed on the body of the pump.

— Speed .....	4250 RPM
— Flow rate .....	140 litres/min.
— Suction filter .....	7 mm
— Maximum pressure .....	4.5 Kg/cm <sup>2</sup>
— Power absorbed .....	kW 2.1



The performance specified is obtained with the drive outlet (PTO) at 540 RPM. For a good result of the treatments this condition **MUST ALWAYS BE OBSERVED** during the machine's operation. Utilisation is permitted with speed rates ranging between 500 and 620 RPM.



00832

10a2. Close the main filler (BP) of the tank.

10a3. Complete the filling with water through the secondary filler (BS), by keeping PTO in running.

10a4. Close the cover of the secondary filler (BS).

10b. **WITH POWDER PRODUCTS, WHEN USING THE MIXER (IF FORESEEN)**

10b1. Pour the powder medicine dose into the cup-like filter of the main filler (BP).

10b2. Close the main filler (BP) of the tank.

10b3. Open the cock (P12), by positioning the lever on "a" (or position "1" for E.P.A. versions).

10b4. Complete the filling with water through the secondary filler (BS), by keeping PTO in running.

10b5. Close the cock (P12), by positioning the lever on "c" (or position "2" for E.P.A. versions).

11. Move to the place to be treated, by keeping the mixture agitation at a 500 r.p.m. PTO turning rate along the whole way.

#### FILLING DIRECTLY IN THE TREATMENT AREA:

12. Disengage the power take off (PTO)



13. **Stop the tractor and remove the key from the control panel.**

14. Make sure that the fan is still. Engage the impeller to the multiplier, as indicated at paragraph 8.1.b.



**Tighten the protection-securing nuts properly.**

15. Start the tractor.

16. Engage the Power Takeoff and set it up to a running rate of at least 500 r.p.m., in order to carry out a further agitation.



**Use ONLY the PTO at 540 rpm. Engage the PTO with the engine of the tractor at low speed and with maximum modularity, obtaining soft and progressive graft and avoiding abrupt starts of the cardan shaft**

17. Regulate the operating pressure, by acting on the pressure regulator (P5) (or electric E5, for versions where provided) with the distributor, hand (P9) or electric (E9), open (DISTRIBUTION).

18. CARRY OUT THE TREATMENT (See the paragraph 11.3).

### 8.3 - FILLING WITH THE SPECIFIC PIPE

(optional on demand)



**Before utilisation, check the operation and proper sealing of the bottom-drawing valve by pouring water in the piping.**



**THE PUMP MUST NEVER RUN DRY.**

EXECUTION:

1. Disengage the fan, see point 8.1.a.

2. For the versions on which it is foreseen: check that the cock (P18) is open: (lever positioned on "1").

3. For the version where foreseen: verify that the spray-line rinsing cock (P15) is on "1" position.

4. Verify that the outlet on the faucet (P2) is closed by the special plug with chain.

5. Position the lever of the 3-way cock (P2) to "B".



6. Close the cocks of the 2-way distributor:

a. if electric (E9), position to "OFF" the quick-break switches on the electrical control panel (E10) or on the E.P.A. control unit.

b. if manual (P9), the levers are to be lowered (horizontally positioned);

### 8.1.b Fan engagement to perform the treatment

#### EXECUTION:

1. Disengage the power take off (PTO)
2.   **Stop the tractor, remove the key from the control panel and check that the fan is stopped.**
3. Unscrew the nuts that fix the protection mobile cover and remove it to enter the release.
4. Fully press the spring push button, push the front body forward, if necessary, turning it to the right or left, until the frontal teeth of the joint engage the corresponding teeth of the pulley; at the same time, the spring push button must return to the outward position. This way, the body is again integrated with the pulley, thus transmitting the movement to the fan.
5. Reposition the mobile protection cover and suitably tighten the securing nuts.
6. Start the tractor.

### 8.2 - FILLING THROUGH POURING FROM THE TOP



For this type of filling, use the supplementary filler (BS) located in the upper side of the tank, towards the rear of the sprayer.

**THE INLET OF THE FILLER PIPING MUST NEVER COME INTO CONTACT WITH THE ANTI-PARASITIC MIXTURE: IT MUST ALWAYS BE KEPT AT A SAFE HEIGHT ABOVE THE TANK FILLER AND MUST BE EQUIPPED WITH A NON-RETURN VALVE.**



**THE PUMP MUST NEVER RUN DRY**

#### EXECUTION:

1. Disengage the fan (for the version where foreseen): see point 8.1.a.
2. Verify that the lever of the 3-way cock (P2) it's in the position "A".
3. For the version where foreseen: verify that the spray-line rinsing cock (P15) is on "1" position.
4. Completely open the pressure regulator (P5), by rotating counterclockwise the handle or by setting the pressure at zero (keep the joystick on "-" for about 15 seconds) if the atomizer is provided with electric regulator (E5).
5. For the versions on which it is foreseen: verify that the three-way cock (P18) lever of the additional agitation pump (P19) on "1"; make sure that the tap (P21) is open.
6. Close the cocks of the 2-way distributor:
  - a. if electric (E9), position to "OFF" the quick-break switches on the control panel (E10) or on the control unit for E.P.A. versions;
  - b. if manual (P9), the levers are to be lowered (horizontally positioned);
7. Close the cock (P12) by positioning the lever on "c". (on "2" position for E.P.A. versions).
8. Pour some water into the tank, for about 1/3 of its capacity, by acting from the secondary filler (BS).
9. Start the tractor and engage the PTO; then bring it up to a 500 r.p.m. rate.



**Use ONLY the PTO at 540 rpm. Engage the PTO with the engine of the tractor at low speed and with maximum modularity, obtaining soft and progressive graft and avoiding abrupt starts of the cardan shaft.**

#### 10a. WHEN NOT USING THE MIXER (WITH MEDICINE MIXTURES OR LIQUID PRODUCTS)

- 10a1. Pour the mixture of water and plant protection product previously prepared (or the liquid product) (and the possible washing water for the medicine packs and for the instruments used for preparing the mixture) into the main filler (BP).

### 4.5.4 - Filters

Filter (P7) .....	250 lt/min - 50 mesh
Tank filling filters .....	18 mesh
Filler pipe filter	
(optional) .....	16 mesh

### 4.5.5 - Tanks

Sprayer model	Tank volume (lt.)	Residual volume (lt.)
Blitz 45	600	7,8
Blitz 45 - 50	800	8,0
Blitz 45 - 50 - 55	1000	8,2
Blitz 50 - 55	1500	11,0
Blitz 55	2000	14,5

### 4.5.6 - Fans

	Blitz 45	Blitz 50
	450 mm Diameter 4500 rpm. air delivery: 5400 m <sup>3</sup> /h air speed: 188 m/s	500 mm Diameter 4000 rpm. air delivery: 7750 m <sup>3</sup> /h air speed 175 m/s
Blitz 55	Blitz 55 Super	Blitz 55 Extra
550 mm Diameter 3500 rpm. air delivery: 12500 m <sup>3</sup> /h air speed: 150 m/s	550 mm Diameter 3700 rpm. air delivery: 14000 m <sup>3</sup> /h air speed: 170 m/s	550 mm Diameter 3900 rpm. air delivery: 15500 m <sup>3</sup> /h air speed: 180 m/s

### 5.1- HITCHING TO THE TRACTOR



Check that the tractor "permissible trailed weight" is compatible with the sprayer weight, when this is fully loaded and complete with the equipments mounted for the treatment (see the Paragraphs "3.3" - "4.6" as well as the jointed documents).



THE TRACTOR'S POWER TAKE-OFF (PTO), UNDER ALL UTILISATION CONDITIONS, MUST PROVIDE A POWER EXCEEDING THAT ABSORBED BY THE SPRAYER.

Pairing suggested for tractors of at least	BLITZ 45	BLITZ 50	BLITZ 55	BLITZ 55S	BLITZ 55E
CV SAE	45	65	70	80	90
kW	33	48	52	58	66

BLITZ\_004



The hitching has to be carried out on a plane surface with a suitable consistency, after having checked that all the people not charged with the operation moved away, as well as the children and the animals possibly present.



On-road use is permitted only in accordance with the rules in force in the country of use, without having loaded chemicals in the tank.

#### 5.1.1 - Sprayer with standard drawbar

##### EXECUTION

- The tractor drawbar, if it is envisaged, has to be on central position.
- Drive the tractor near the sprayer and aligned with respect to it.
- Stop the tractor and remove the key from the control panel.**
- Select the trail eye position: either up or down.  
The sprayer has to operate as horizontally as possible. If the ground allows it, intervene by regulating also the axle height.
- Position the drawbar trail eye at the height of the trail fork, by acting on the support foot.
- Start the tractor and insert the trail eye into the trail fork, by following the instructions supplied at preliminary notes.
- Stop the tractor and remove the key from the control panel.**
- Fasten the drawbar to the frame.
- Lock the drawbar, by inserting the special peg with safety clip pin.
- Lift the support foot and detach it from the drawbar.
- 10a. If necessary, regulate the drawbar length by fastening the support foot to the frame (Position B).
- 10b. By acting on the support foot, adjust its height, in such a way that it is possible to let the drawbar slide without any effort; remove the through bolt and loosen the two locking screws. Adjust the drawbar position, then lock it again.
- 10c. Lift the support foot and remove it from the frame.
- Fasten the support foot to the frame, on stowage position (Position C).

FILLING MUST BE CARRIED OUT WITH THE MACHINE ON A FLAT SURFACE. ON THE SITE, BEFORE THE OPERATION, THE DOSES OR THE MIXTURES TO BE Poured INTO THE TANK MUST BE PREDISPOSED.



IT IS NECESSARY TO ALWAYS MAKE USE OF PERSONAL PROTECTION.

### 8.1 - FOREWORD - USE OF THE FAN DISENGAGEMENT

(for the version where foreseen)

#### 8.1.a Disengagement of the fan

##### EXECUTION:

- Stop the tractor, remove the key from the control panel and check that the fan has stopped.**
- Unscrew the nuts that fix the protection mobile cover and remove it to enter the release tunnel.

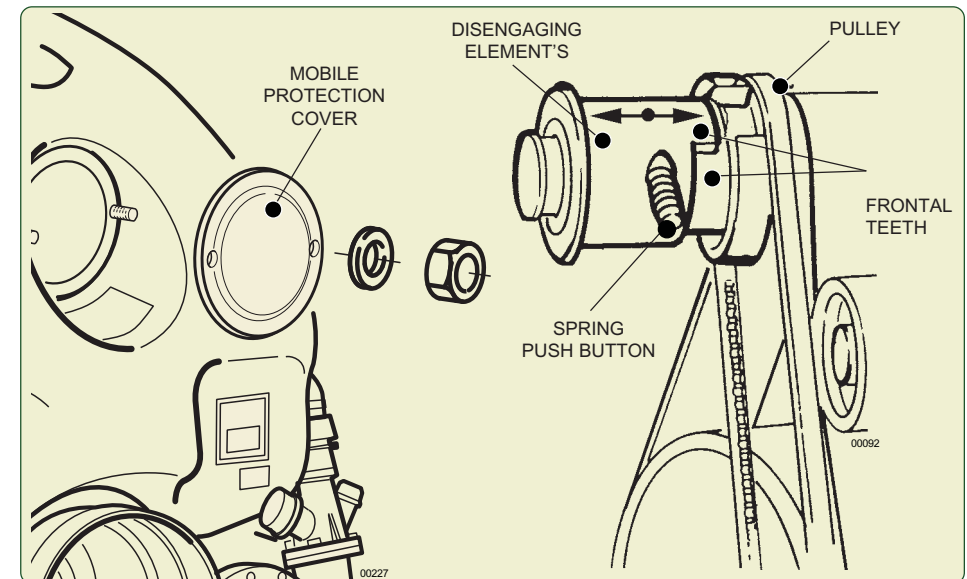

- Fully press the spring push button and pull the front element until it springs out. The body disengaged from the retaining joint must turn freely: the pump will operate and the fan will thus be excluded.
- Reposition the mobile protection cover and fasten the locking nuts properly.
- Start the tractor and carry out the filling operation.



## 7.6 - E.P.A. Kit - DELIVERY PROPORTIONAL ADVANCEMENT

(for the version where foreseen)

The computerized E.P.A. system executes the monitoring of the distribution parameters for the active automatic control of the distribution proportional to the feed.

Through the constant takeover of the feed speed and the range of the product it is able to regulate the pressure continuously to keep the quantity of distributed product constant in relation to the treated surface.

The Kit is available in two versions:

- Version "Teejet® 76AB";
- Version "Teejet® 844AB."

Both versions are constituted from:

1. Magnetic induction proximity sensor (speed survey);
2. Pressure transducer (pressure survey);
3. Motorized electric valve (pressure regulation);
4. Computerized unit;
5. Dedicated printer ("Teejet® 844AB" version only).

For further information refer to the specific handbook.

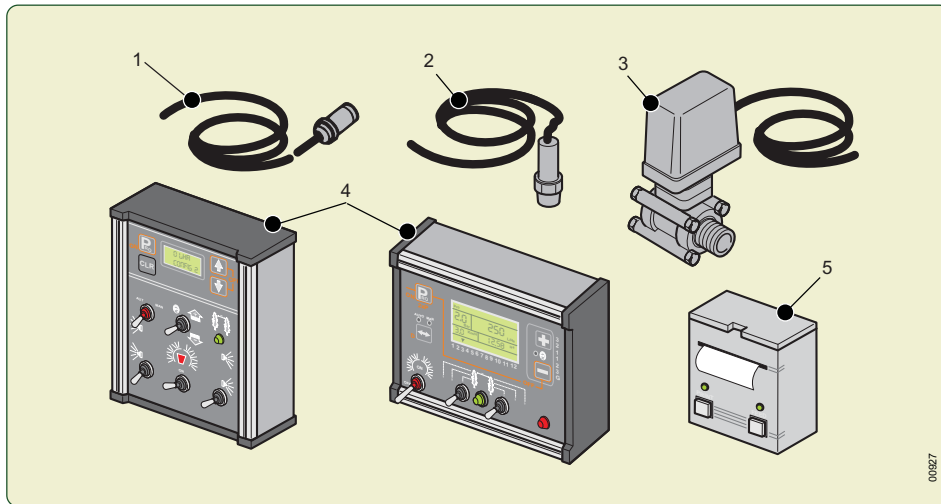

00927



After every regulation, carefully tighten the screws and the bolt involved in the carried out operation.

12. After having properly fastened the fastening bracket supplied with the equipment, place the electrical control box (E8) or the manual control (P8) (for the version where foreseen) near the driver, inserting the power supply cable into the tractor plug.
13. Screw the two feeding pipes to the distribution device (head).

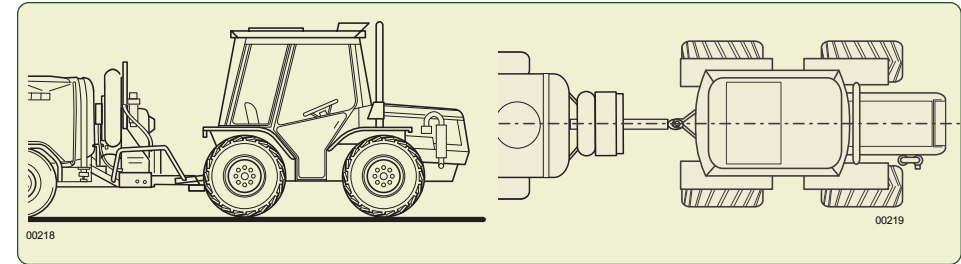

00218

00219

### 5.1.2 - Sprayer with steering drawbar

EXECUTION

1. Start the tractor and move it near the sprayer and aligned with it.
2. **Stop the tractor and remove the key from the control panel.**
3. Extract pin (3), let the mobile body (4) advance and lock it on position by re-inserting pin (3);
4. Extract the pivot (1) of the tractor hook (5);
5. Introduce drawbar eye into the traction hook (5) and introduce again the locking pivot (1);
6. Fix the pivot by means of the relevant safety split pin (2);

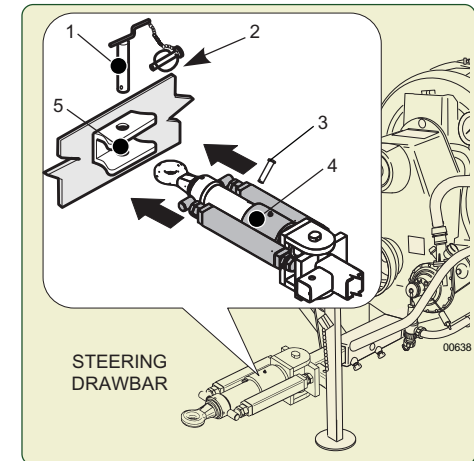

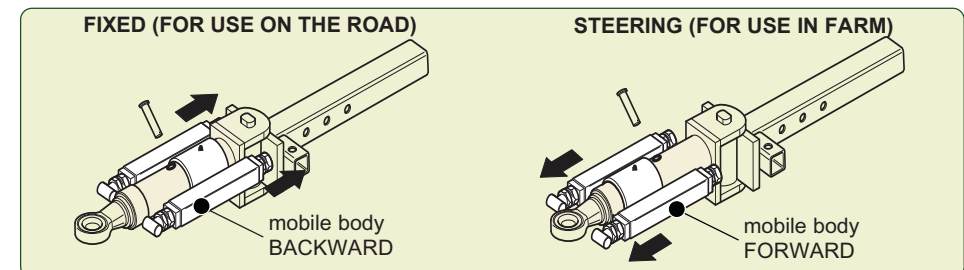

00638

The steering drawbar can be locked in the two positions illustrated in the Figure:



### 5.1.3 - Drawbars for the coupling to the mechanical power lift

#### EXECUTION FOR THE 3 POINT CONNECTION MODEL

1. Start the tractor and move it near the sprayer and aligned with it.
2. Position the arms of the tractor mechanical power lift at the same height of the draw bar pegs (3).
3.   **Stop the tractor and remove the key from the control panel.**
4. Insert the toggle joints on the machine pegs, locking them there by means of the clip pins (1).
5. Hook the 3<sup>rd</sup> point-tie rod from the tractor to the sprayer, **and lock it with by means of the peg and the clip pin (2).**
6. Screw down the tie rod and put it into tension. **N.B.: lock the 3<sup>rd</sup> point-tie rod by means of the purposed lock ring.**
7. Lock the coupling by means of the purposed tightener of the chains of the mechanical power lift arm.

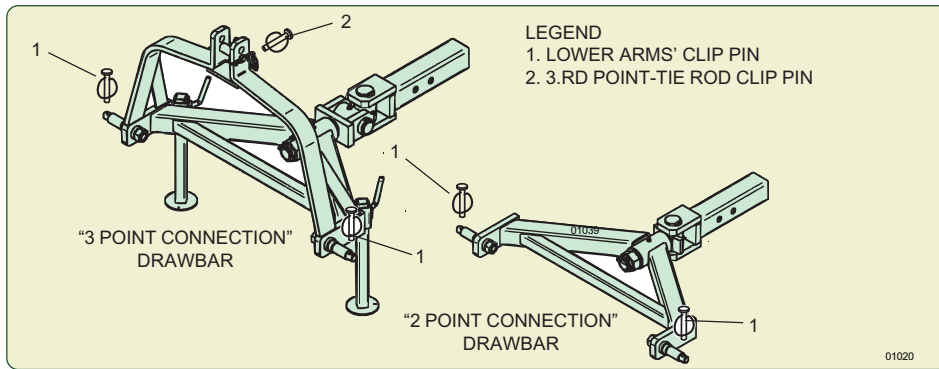



#### EXECUTION FOR 2 POINT CONNECTION MODEL

1. Carry out the same operations described for the 3 point-tie rods steering draw bar, exception made for step 5.

### 5.1.4 - Bracket drawbar

#### EXECUTION

1. Start the tractor, and move it near the sprayer and aligned with it.
2.   **Stop the tractor and remove the key from the control panel.**
3. Mount the drawbar (1) by inserting the toggle joints on the drawbar pegs, and lock it there by means of the clip pins (2).
4. Align the bracket draw bar with the central hole of the drawbar (1), and adjust the height of the mechanical power lift in such a way to get the drawbar centred between the two draw bar plates.
5. Move the tractor backwards until the drawbar hole coincides with the draw bar holes.
6. Extract the pintle (3) of the tractor pull hook and insert it into the draw bar/drawbar coupling hole.
7. Secure the pintle (3) by means of the purposed safety split pin (4).

### 7.3 - ROTARY BLADES' HYDRAULIC MIXER (Patent n° 1295858)

(for the version where foreseen)

The mixer consists of a header, to which some oriented feed openings, equipped with mixing paddles, are applied. The mixer is mounted inside the tank through two hollow supports, a front and a rear one, which are equipped with bushes allowing it to rotate. The water coming from the additional pump is conveyed, through the supports, to the header and from that one to the oriented feed openings. The water streaming out causes, as a reaction, the mixer rotary movement, so adding to the mixture hydraulic agitation, the mechanical agitation caused by the paddles' movement.

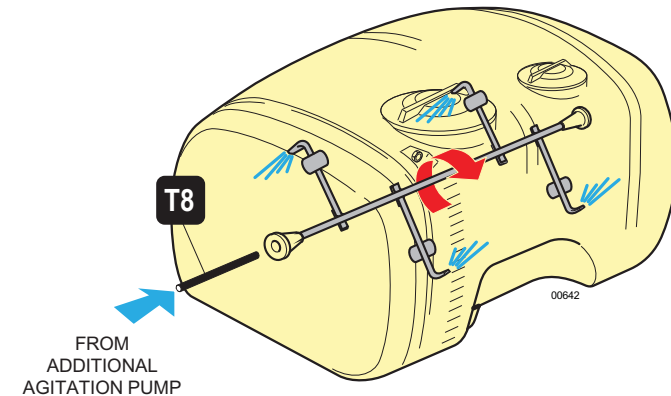

### 7.4 - REAR LIGHTS KIT

(for the version where foreseen)

The wired backlights kit is constituted by two complete back lights (parking lights, stop lights and direction indicators) and with hangers for the anchorage to the frame of the atomizer.

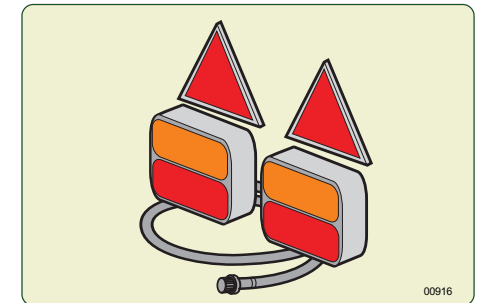

### 7.5 - PRESSURE ELECTROREGULATOR

(for the version where foreseen)

The pressure electroregulator can be installed in substitution of the manual regulator. The joystick for the electroregulator control is in the electric switchboard (E10).

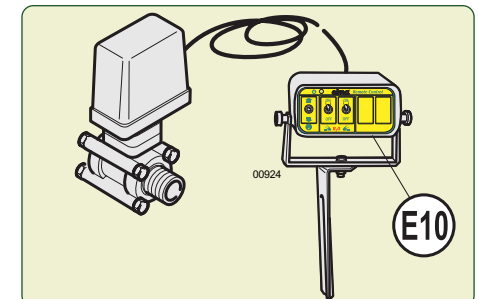

### 7.1 - FILLER PIPE

The pipe is provided with a coupling elbow fitting and with a **bottom-drawing valve**. This is used for the filling of the tank.

It must be connected to the pump suction (P4) instead of the chain-held stopper.



The assembly has **ALWAYS** to be carried out with the lever of the cock (P2) positioned on "B".



**USE ONLY IF CONCURRED FROM THE LAWS OF THE COUNTRY WHERE THE SPRAYER IS USED.** Before utilisation, check the operation and proper sealing of the bottom-drawing valve by pouring water in the piping.

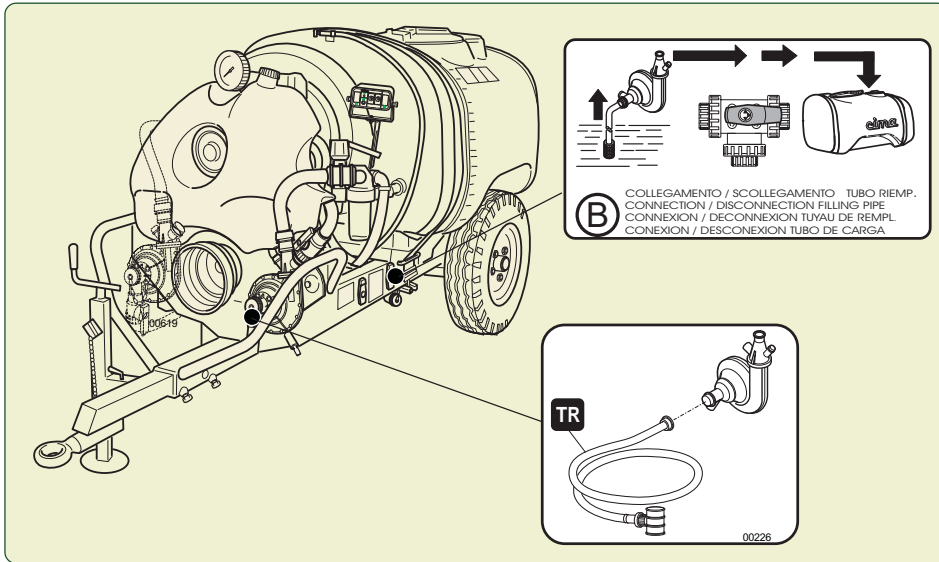

### 7.2 - ELECTRICAL SWIVELLING DEVICE

It is an accessory for modifying the direction of the spraying. It is used only with some types of distribution devices, spraying one side only.



All indications and instructions are provided in the "Distribution heads - Operation and maintenance instruction" booklet of the distribution devices with which it can be used.

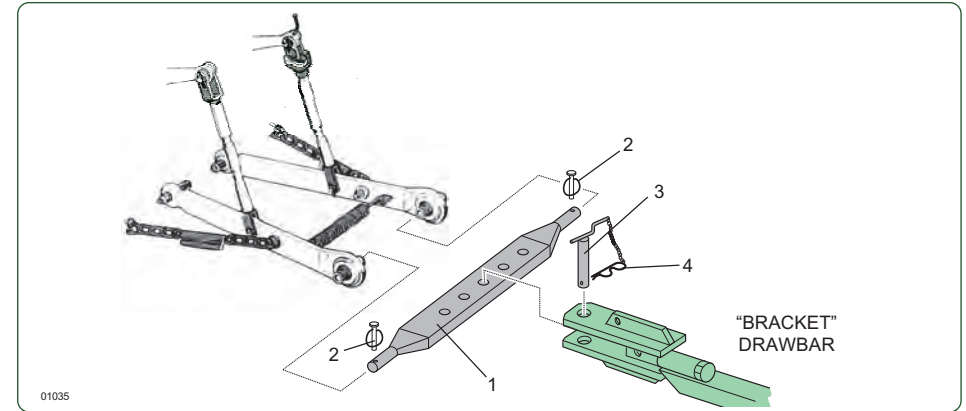
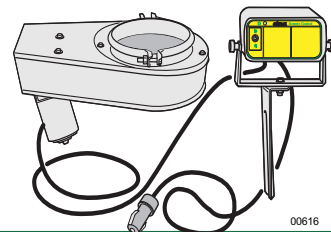

### 5.2 - MOUNTING OF THE TRANSMISSION SHAFT



The mounting, disassembling or possible other interventions on the transmission shaft must be carried out with the engine switched off and with the starter key removed from the tractor's control panel.



**USE TRANSMISSION SHAFTS WITH CE CERTIFICATION.** OBSERVE THE REGULATIONS CONTAINED IN THE USE AND MAINTENANCE BOOKLET PROVIDED BY THE SHAFT MANUFACTURER.

#### 5.2.1 - Cardan transmission shafts

The transmission shaft mounting has to be carried out when the 2 PTO are coaxial, or, shouldn't this be possible, when their axes are parallel. In this case, the misalignment has to be such to PREVENT the transmission shaft articulated joints to operate with an angle exceeding a 15° maximum width.

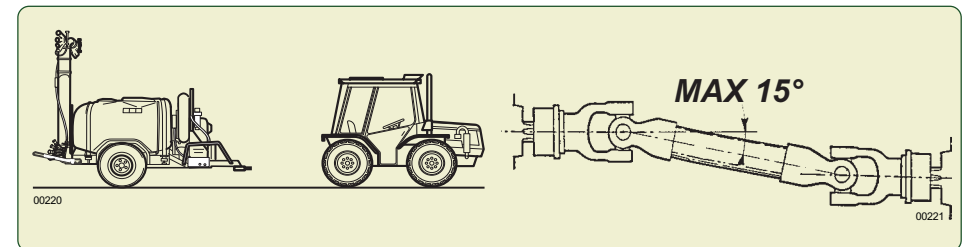

Those working positions can be reached by acting on the drawbar, which is adjustable both in height and in length.

When some curves are carried out with the power takeoff inserted, the steering angle can be 30° only if the trailing point is equally distanced with respect to the motion drives. Beyond such a value, it will be necessary to disengage the power takeoff, in order to avoid any possible breaks and dangers.

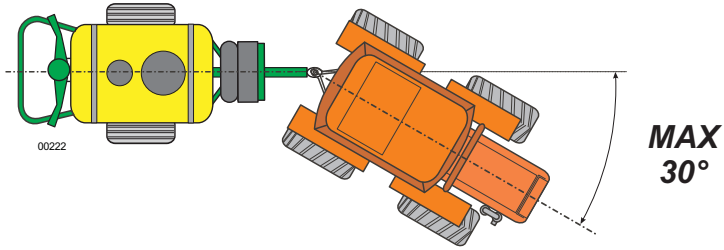

MAX  
30°



ANYWAY, THE USER HAS BOTH TO FOLLOW AND TO OBSERVE ALL THE INDICATIONS SUPPLIED IN THE USE AND MAINTENANCE BOOKLET PROVIDED BY THE CARDAN SHAFT MANUFACTURER.

**DEFINITION OF THE TRANSMISSION SHAFT LENGTH.**

1. After having hitched the sprayer to the tractor, set the operative unit to the maximum steering position allowed (without cardan shaft and with PTO disengaged).
2. Measure the distance "D" between the grooves of the two PTOs.
3. Length "L" of the transmission shaft (refer to the picture) to be deployed, measured between the 2 stopping pawls and with joint closed, must be **40÷50 mm** lesser than distance "D": " $L \leq D - 40 \div 50 \text{ mm}$ "

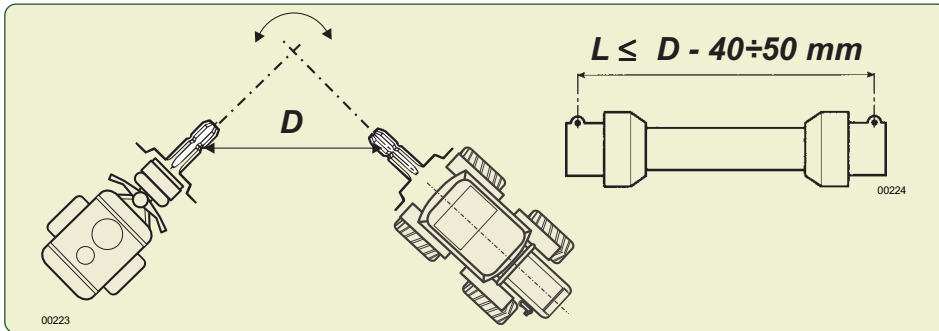

**5.2.2 - Transmission with a single homocynetic joint (on the tractor side) for sprayers with steering drawbar**

The transmission shaft mounting has to be carried out when the 2 PTO are coaxial, or, shouldn't this be possible, when their axes are parallel.

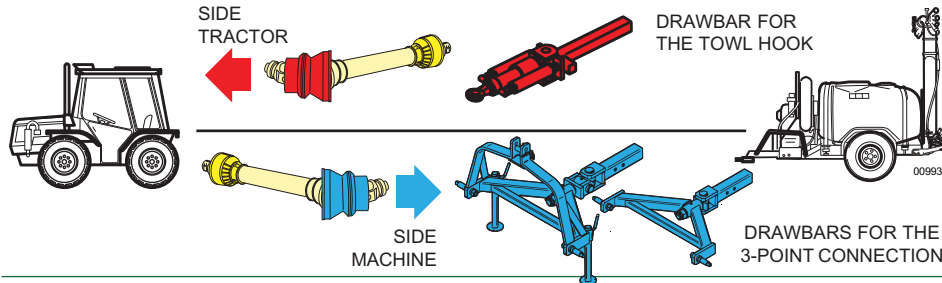

**6.1 - ELBOW FITTINGS OF DISTRIBUTION DEVICES**

The connection elbows both support and connect the distribution devices from the outlet of the connection tunnel, to the fan. The connection elbows are being supplied with the trailed sprayers Series BLITZ 45 and BLITZ 50, while for the trailed sprayers Series BLITZ 55, the connection elbows are being supplied with the distribution sprayhead.

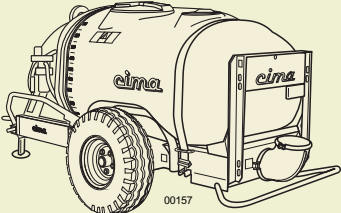
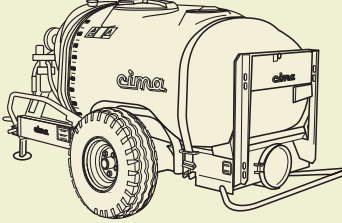
COMPLETE SERIES	BLITZ 45 - BLITZ 50	BLITZ 55 - 55S - 55E
Fan outlet opening	Inside diameter: 175 mm	Inside diameter: 250 mm
STANDARD BASIC MODELS		
Sprayers delivered:	90° ELBOW	WITHOUT ELBOW
Outlet opening	VERTICAL back	HORIZONTAL back



In the handbook "Distribution devices - Operation and maintenance instructions" the right type of elbow is indicated, together with the assembling instructions. A specific assembling diagram of each type of sprayhead is also supplied with the spare parts catalogue.



Every distribution device is supplied with its own **USE AND MAINTENANCE** booklet that is, or will have to be, attached to this publication and will constitute one of its integral parts.

The "Distribution devices – Operation and maintenance instructions" manual both shows and describes the wide range of the distribution devices (heads), to be employed on each sprayer in order to assure a perfect covering, always answering to the real requirements of the culture to be treated. All the heads can be very easily oriented and regulated, so to optimise the necessary covering.

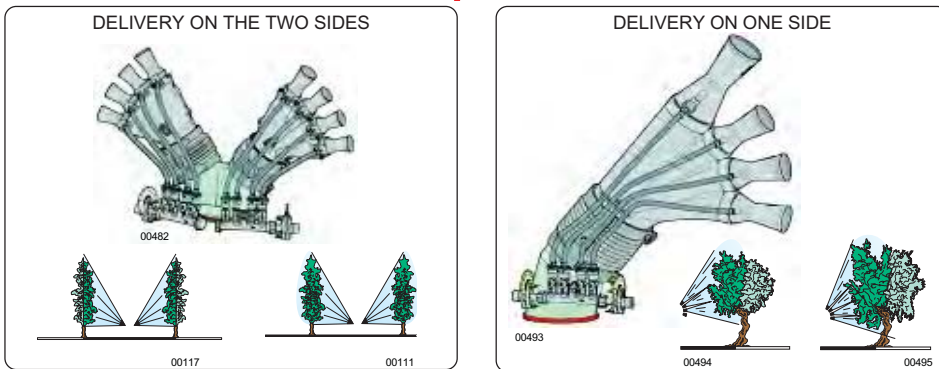
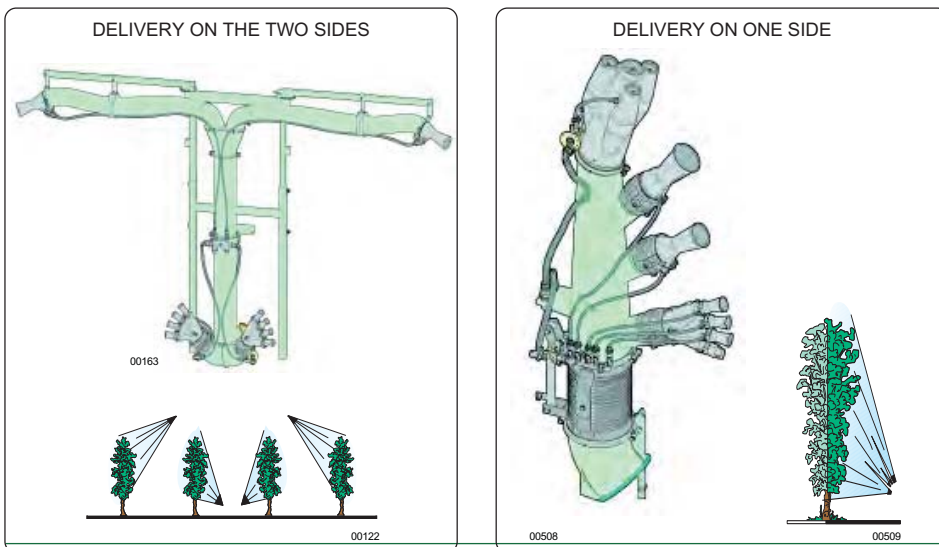
**Simple heads**

**Combined heads**

With drawbar for the tow hook the homocinetic joint **HAS TO BE MOUNTED ON THE TRACTOR PTO**, with drawbars for the 3-point connection the homocinetic joint **HAS TO BE MOUNTED ON THE SPRAYER PTO**. On these conditions, it is possible to carry out curves having a 70/80° steering angle, with the power takeoff turning.



**ANYWAY, THE USER HAS BOTH TO FOLLOW AND TO OBSERVE ALL THE INDICATIONS SUPPLIED IN THE USE AND MAINTENANCE BOOKLET PROVIDED BY THE HOMOCYNETIC CARDAN SHAFT MANUFACTURER.**

**DEFINITION OF THE TRANSMISSION SHAFT LENGTH**

- Follow the same procedures described at Paragraph 5.2.1.

**5.3 - INSTALLATION OF REMOTE CONTROLS**
**5.3.1 - Electrical control panel - E10**

- 1 - Fix the fastening bracket near to the driver (if not already available on the tractor).
- 2 - Insert the bayonet support of the control panel in the securing clamp and position it so that the controls are fully visible and accessible during use.
- 3 - Connect the distribution piping (T5) to the hydraulic circuit of the distribution device (head) mounted on the machine (follow the instructions of the specific "use and maintenance" book-let which is supplied with it).
- 4 - Connect the feeding pipe (T4) with the electrical distributor (E9).
- 5 - Connect the power supply cable "W1" plugging it in the socket of the tractor.

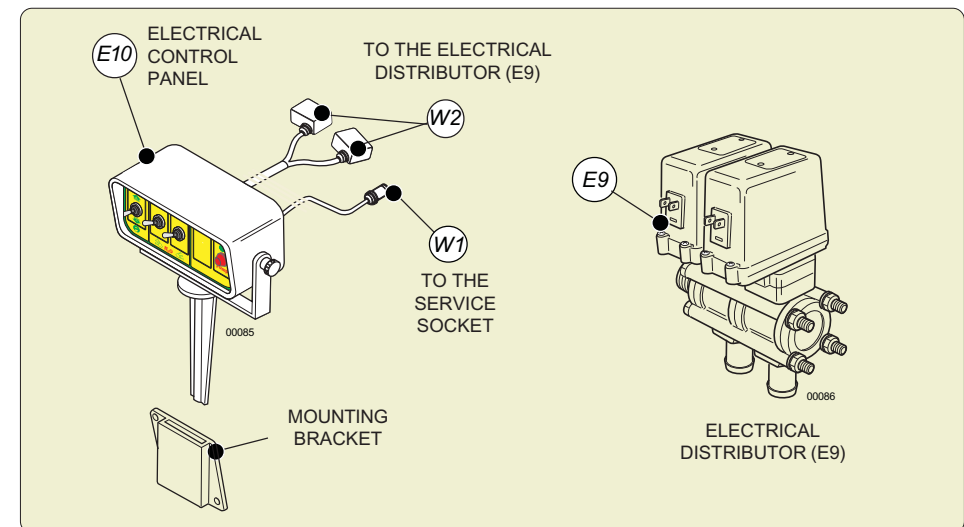



Position the electrical cables W1 and W2 in such a way as to avoid risking their being wrenched off during treatments. If necessary, use some securing clamps. A sudden interruption of power will lock the 2 solenoid valves of the electrical distributor "E9". Should this fault take place when they are in the open position, it is necessary to:

- Stop the tractor and remove the key from the control panel.
- Position the cock (P2) to "3".
- Restore the electric current.

IN CASE OF A PIPE BURST:

- 1 - Stop the tractor and remove the key from the control panel.
- 2 - Close the electrovalves (E9), the switches on the control panel (E10) must be on OFF.
- 3 - Close the pressure regulator (P5) turning clockwise the pressure regulation knob or keep the joystick (E10) in position "+" for at least 15 seconds on the electrical control box.
- 4 - Replace the broken pipe (for the elimination of these parts, please follow the current regulations).

**5.3.2 - Manual 2-tap distributor - P9** (for the versions where foreseen)

- 1 - Mount the fastening bracket on the tractor within the driver's reach (if this is not already present on the tractor).
- 2 - Insert the distributor's bayonet support in the securing bracket and position it so that the controls are fully visible and accessible during use.
- 3 - Connect the feeding pipe (T4)
- 4 - Connect the distribution piping T5 to the hydraulic circuit of the distribution device (head) mounted on the machine (follow the instructions of the specific "use and maintenance" book-let which is supplied with it).

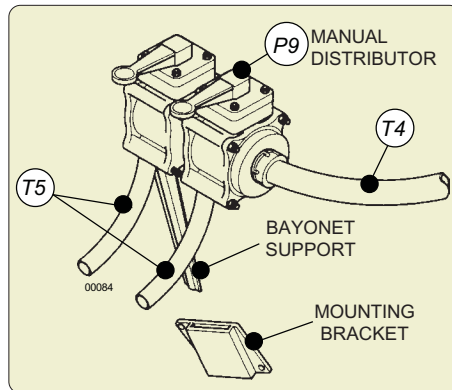

Position the distribution piping T5 and feed piping T4 so as to avoid the risk of suffering damage or breakage during spraying. It may be needed to shorten the pipes.

IN CASE OF BREAKAGE:

- 1 - Stop the tractor and remove the key from the control panel.
- 2 - Close the 2 taps of distributor (P9).
- 3 - Move the 3-way cock (P2) lever to position "3", filling.
- 4 - Close the cock with pressure regulating handgrip (P5) (turn it clockwise).
- 5 - Repair or replace the broken pipes (for the elimination of these parts, please follow the current regulations).

**5.3.3 - E.P.A. Control Unit**



Act in a similar way as indicated for installing the electric control power plant (E10) (see Paragraph 5.3.1.)



Position the electric cables in such a way to prevent them from getting torn during the treatment.

