



BLITZ

OPERATION AND MAINTENANCE INSTRUCTION

cima[®] S.p.A.

27040 Montù Beccaria - Loc. Molino Quaroni - (PV) - ITALIA
Tel. +39.0385.246636 r.a. - Fax +39.0385.246637
<http://www.cima.it>

cima[®]

atomizzatori e impolveratori

Dear Customer, thank you very much!

*We want to congratulate with you, for having chosen a **cima**® sprayer.*

Your choice shows the wisdom of the well-informed Purchaser, aware of the fact, that the required features of quality, technique and reliability must be satisfied at the right price!

Our continuous engagement in R&D and in testing our machines allows us to realize products able to offer the best performances, a high reliability and a great easiness of use at the same time !

Our first goal, is to get our Customers happy for having met us!

The "Spare parts catalogue" of this sprayer/sprayhead is available in the "restricted area" on website www.cima.it.

In order to accede, use:

Username: **sprayer**
Password: **844719KE**

Where we are



Warranty conditions

1. Warranty

The goods sold are covered by a general warranty that ensures the good quality of the materials, solid construction and regular operation for twelve months from the date of delivery.

During the warranty period, C.I.M.A. S.p.A. pledges to replace, free of charge, the parts which, in his unquestionable judgement, are considered defective, provided that the flaws and defects cannot be attributed to poor use or maintenance of the product or an unreasonable, inappropriate and unsuitable use of such product with respect to the technical instructions supplied by C.I.M.A. S.p.A. The products which have been modified, repaired, assembled or tampered with by a third party, consumption materials and the parts subject to wear and tear are excluded from the warranty. The replacements will be made free CIMA S.p.A. works and the buyer will be responsible for all shipping and return expenses. The buyer will be responsible for the costs of the labour needed to replace the parts considered defective. The resolution of the contract and any compensation for damage cannot be claimed by the buyer except for serious faults to be proven by said buyer. The warranty will no longer be extended to the buyer if he does not respect the agreed upon payment procedures and terms.

2. Reporting defects in goods

The claims for flaws or defects in the goods shall be submitted within eight days from when such goods are received or from when hidden defects are discovered, in writing, by means of a registered letter.

No claim can be made, nor as an exception, in a court of law if the goods, for which the claim is submitted, have not been regularly paid.

Any claim concerning a single delivery of goods will not exonerate the buyer from his obligation to pick-up the remaining quantity of goods within the limit of the order.

3. To pass safety information

The buyer is responsible towards the final user for the safety information shown on the sale documentation, concerning use limit, performances and product features.

4. Validity and acceptance

The guarantee is valid if the CERTIFICATE OF GUARANTEE is sent, to C.I.M.A. S.p.A., with every part of it filled in, within 30 days from the date of purchase (referring to the date of the postmark).

Informative according to the D. L. n. 196 of the 2003 ("Code in matter of protection of the personal data")

Dear customer,
according to art. 13 of the D.Lgs. 196/03 "Unique Text on Privacy" (referred to as 'Law' here below) we would like to inform you about the following:

- 1) the personal data given to C.I.M.A. S.p.A. when filling in the "Warranty Certificate" will be processed respecting the above mentioned regulations and the rules of privacy stated there in;
- 2) according to art.4, paragraph 1, lett. a) of the Law, the handling of personal data signifies "whatever operation or set of operations carried out (even without the aid of electronic instruments) regarding the collection, recording, organization, conservation, research, handling, modification, selection, extracting of details, comparison of, use of, connecting to, blockage, passing on, distributing, cancellation and destruction of data, even if not recorded in a data bank";
- The handling of the personal data given is carried out by automatized and non automatized instruments, with controlled access and as specified by clause B of the Law;
- 3) the data are processed to an institutional end, in connection with or useful to the activities of C.I.M.A. S.p.A. for filing, processing and management;
- 4) the data are collected and recorded so that access is only allowed to authorized persons and they may be processed exclusively by C.I.M.A. S.p.A. to the above mentioned end;
- 5) the collected data may only be given to a third party exclusively in connection with accounting imposed by fiscal law and in the case of demands from the judicial authority.

In addition we inform you that any interested party may exercise his rights mentioned in art.7 of the Law; in the exercise of such rights the interested party may delegate or give a proxy, in writing, to persons or associations. The authority to carry out this processing is C.I.M.A. S.p.A., represented in person by a lawyer.

The data processing is done by instruments fit to guarantee the safety and privacy as specified in clause B of the Law.

Low volume sprayers trailer-mounted models

Blitz

Model:

Serial Number:

(Publication N° LUM-BLITZ-06-EN)

OPERATION AND MAINTENANCE INSTRUCTIONS

©CIMA S.P.A. 1996 - 2009 Private property.

Any reproduction, even if partial, is forbidden if not preventively authorized in writing by the Cima S.p.A. company.



CIMA S.p.A. - 27040 Montù Beccaria - Loc. Molino Quaroni - (PV) - ITALIA

Tel. +39.0385.246636 r.a. - Fax +39.0385.246637

<http://www.cima.it>



CERTIFICATE OF WARRANTY

The warranty will not be considered valid if this coupon, with every part of it filled in, is not mailed to the following address: C.I.M.A. S.p.A. - 27040 Montù Beccaria, Loc. Molino Quaroni - (PV) - Italy), or sent by fax to the following number: +39.0385.246637, within 30 days from the date of purchase.

Last name, Name or
NAME OF THE FIRM

ADDRESS

Place PROVINCE ZIP

e.mail (*) telephone (*)

Date of purchase INVOICEN.

MACHINE MOD. MATRICULATION N.

SPRAYHEAD MOD.

Dealer's stamp (compulsory)

(*) NOT COMPULSORY DATA

PRIVACY

Consent for the personal data processing- **PROTECTION OF THE PRIVACY** .
I authorize you, according to the D.Lgs. 196/03 "Consolidated Text about the Privacy" to the processing of my personal data in observance of the law above mentioned, for the indicated purposes, and so that they can be communication to the subjects for the declared purposes.

Date Signature

tagliare lungo la linea tratteggiata

Warranty conditions

1. Warranty

The goods sold are covered by a general warranty that ensures the good quality of the materials, solid construction and regular operation for twelve months from the date of delivery.

During the warranty period, C.I.M.A. S.p.A. pledges to replace, free of charge, the parts which, in his unquestionable judgement, are considered defective, provided that the flaws and defects cannot be attributed to poor use or maintenance of the product or an unreasonable, inappropriate and unsuitable use of such product with respect to the technical instructions supplied by C.I.M.A. S.p.A. The products which have been modified, repaired, assembled or tampered with by a third party, consumption materials and the parts subject to wear and tear are excluded from the warranty. The replacements will be made free CIMA S.p.A. works and the buyer will be responsible for all shipping and return expenses. The buyer will be responsible for the costs of the labour needed to replace the parts considered defective. The resolution of the contract and any compensation for damage cannot be claimed by the buyer except for serious faults to be proven by said buyer. The warranty will no longer be extended to the buyer if he does not respect the agreed upon payment procedures and terms.

2. Reporting defects in goods

The claims for flaws or defects in the goods shall be submitted within eight days from when such goods are received or from when hidden defects are discovered, in writing, by means of a registered letter.

No claim can be made, nor as an exception, in a court of law if the goods, for which the claim is submitted, have not been regularly paid.

Any claim concerning a single delivery of goods will not exonerate the buyer from his obligation to pick-up the remaining quantity of goods within the limit of the order.

3. To pass safety information

The buyer is responsible towards the final user for the safety information shown on the sale documentation, concerning use limit, performances and product features.

4. Validity and acceptance

The guarantee is valid if the CERTIFICATE OF GUARANTEE is sent, to C.I.M.A. S.p.A., with every part of it filled in, within 30 days from the date of purchase (referring to the date of the postmark).

Informative according to the D. L. n. 196 of the 2003 ("Code in matter of protection of the personal data")

Dear customer,
according to art. 13 of the D.Lgs. 196/03 "Unique Text on Privacy" (referred to as 'Law' here below) we would like to inform you about the following:

1) the personal data given to C.I.M.A. S.p.A. when filling in the "Warranty Certificate" will be processed respecting the above mentioned regulations and the rules of privacy stated there in;

2) according to art.4, paragraph 1, lett. a) of the Law, the handling of personal data signifies "whatever operation or set of operations carried out (even without the aid of electronic instruments) regarding the collection, recording, organization, conservation, research, handling, modification, selection, extracting of details, comparison of, use of, connecting to, blockage, passing on, distributing, cancellation and destruction of data, even if not recorded in a data bank";

The handling of the personal data given is carried out by automatized and non automatized instruments, with controlled access and as specified by clause B of the Law;

3) the data are processed to an institutional end, in connection with or useful to the activities of C.I.M.A. S.p.A. for filing, processing and management;

4) the data are collected and recorded so that access is only allowed to authorized persons and they may be processed exclusively by C.I.M.A. S.p.A. to the above mentioned end;

5) the collected data may only be given to a third party exclusively in connection with accounting imposed by fiscal law and in the case of demands from the judicial authority.

In addition we inform you that any interested party may exercise his rights mentioned in art.7 of the Law; in the exercise of such rights the interested party may delegate or give a proxy, in writing, to persons or associations. The authority to carry out this processing is C.I.M.A. S.p.A., represented in person by a lawyer.

The data processing is done by instruments fit to guarantee the safety and privacy as specified in clause B of the Law.

LISTING OF VALID PAGES

This publication consists of 83 pages, subdivided as follows:

N° OF PAGE	REVISION	BASE
from I to VI	06	January 2009
from 1 to 77	06	January 2009

ADDITIONAL RECORDS AND VARIANTS

REVISION	DESCRIPTION
00	First Edition, May 1996
01	Second Edition, November 2001
02	Third edition, January 2002
03	Fourth edition, June 2003
04	Fifth edition, October 2007
05	Sixth edition, April 2008
06	Seventh Edition, January 2009
07	
08	

GENERAL INDEX

1	FOREWORD	1
1.1	PUBLICATION IDENTIFICATION	1
1.2	ATTACHED PUBLICATIONS	1
1.3	PURPOSE OF PUBLICATION	1
1.4	REFERENCE TO REGULATIONS	1
1.5	USING THE MANUAL	1
1.6	UPDATES	2
2	GLOSSARY	3
2.1	TERMINOLOGY	3
2.2	ABBREVIATIONS	3
2.3	DECALS	3
3	GENERAL INFORMATION	7
3.1	MACHINE IDENTIFICATION	7
3.2	TECHNICAL ASSISTANCE	7
3.3	SAFETY NOTICES	7
3.4	SAFETY SYSTEMS	8
3.5	HANDLING OF AGRO-CHEMICALS	9
3.5.1	Storage	9
3.5.2	Specific equipment	9
3.5.3	Disposal of empty containers and agro-chemical residues	10
3.5.4	Personal means of protection	10
4	MACHINE'S STRUCTURAL ANALYSIS	11
4.1	FRAME WITH DRAWBAR	12
4.2	STEERING DRAWBAR	15
4.2.1	DRAWBAR FOR THE TOWL HOOK	15
4.2.2	DRAWBARS FOR THE 3-POINT CONNECTION	15
4.3	FAN SERVO AMPLIFIER	17
4.4	HYDRAULIC CIRCUIT COMPONENTS	18
4.5	TECHNICAL DATA	31
4.5.1	Sprayers dimensions and weights	31
4.5.2	Wheel's: dimensions and operating pressures	32
4.5.3	Technical specifications for fans and pump	32

CERTIFICATE OF WARRANTY

Copy for the owner (to be kept in the manual "Instructions for the use and maintenance")

Last name, Name or
NAME OF THE FIRM

ADDRESS

Place PROVINCE ZIP

e.mail (*) telephone (*)

Date of purchase INVOICEN.

MACHINE MOD. MATRICULATION N.

SPRAYHEAD MOD.

Dealer's stamp (compulsory)

(*) NOT COMPULSORY DATA

PRIVACY

Consent for the personal data processing– **PROTECTION OF THE PRIVACY** .

I authorize you, according to the D.Lgs. 196/03 "Consolidated Text about the Privacy" to the processing of my personal data in observance of the law above mentioned, for the indicated purposes, and so that they can be communication to the subjects for the declared purposes.

Date Signature

10.5	END OF TREATMENT - STORAGE	53
10.5.1	Daily	53
10.5.2	End of seasonal cycle	54
11	TANK AND HYDRAULIC CIRCUIT DRAINING	55
12	LIFTING AND TRANSPORT	56
13	MAINTENANCE OPERATIONS	57
13.1	LUBRICATION	57
13.2	FAN SHAFT SUPPORT OIL LEVEL CHECK	59
13.3	FAN SHAFT SUPPORT OIL REPLACEMENT	58
13.4	CLEANING OF FILTER'S CARTRIDGE	59
13.5	CLEANING OF THE FAN	59
13.6	FAN BELT TENSIONER	60
13.7	PUMP BELT TENSIONER	61
13.8	MAIN TANK FASTENING BELT	61
13.9	TABLE OF MAINTENANCE OPERATIONS	62
14	FAULTS FINDING	63
15	REPAIRS ALLOWED	66
15.1	REPLACEMENT OF PUMP CONTROL BELT	66
15.2	REPLACEMENT OF ELECTRICAL PANEL'S FUSES	67
15.3	PRESSURE GAUGE REPLACEMENT	67
15.4	INSPECTION AND CLEANING PUMP FILTER	68
15.5	CHECK HYDRAULIC DELIVERY	69
15.6	TANK REMOVAL OR REPLACEMENT	67
16	INTEGRATIVE DIAGRAMS	71
16.1	HYDRO-PNEUMATIC DIAGRAM	71
16.2	WIRING DIAGRAM	74
17	NOISE LEVEL	75
18	ATTACHMENT : DECLARATION OF CONFORMITY	76
19	WARRANTY	77
19.1	WARRANTY	77
19.2	REPORTING DEFECTS IN GOODS	77
19.3	TO PASS SAFETY INFORMATION	77



THE OWNER AND/OR THE OPERATOR OF THE SPRAYER ARE NOT PERMITTED TO MODIFY THE STRUCTURE OR THE SPECIFIC OPERATION OF THE SPRAYER ITSELF. ANY REPAIRING INTERVENTION HAS TO BE CARRIED OUT EITHER AT THE DEALERS' OR AT THE C.I.M.A. S.p.A. AUTHORIZED WORKSHOPS, OTHERWISE ANY KIND OF WARRANTY IMMEDIATELY CEASES AND C.I.M.A. S.p.A. IS CLEARED OF ANY CONSEQUENT AND/OR IMPLIED RESPONSIBILITY.

19.1 - Warranty

The goods sold are covered by a general warranty that ensures the good quality of the materials, solid construction and regular operation for twelve months from the date of delivery.

During the warranty period, C.I.M.A. S.p.A. pledges to replace, free of charge, the parts which, in his unquestionable judgement, are considered defective, provided that the flaws and defects cannot be attributed to poor use or maintenance of the product or an unreasonable, inappropriate and unsuitable use of such product with respect to the technical instructions supplied by C.I.M.A. S.p.A.

The products which have been modified, repaired, assembled or tampered with by a third party, consumption materials and the parts subject to wear and tear are excluded from the warranty.

The replacements will be made free CIMA S.p.A. works and the buyer will be responsible for all shipping and return expenses.

The buyer will be responsible for the costs of the labour needed to replace the parts considered defective. The resolution of the contract and any compensation for damage cannot be claimed by the buyer except for serious faults to be proven by said buyer.

The warranty will no longer be extended to the buyer if he does not respect the agreed upon payment procedures and terms.

19.2 - Reporting defects in goods

The claims for flaws or defects in the goods shall be submitted within eight days from when such goods are received or from when hidden defects are discovered, in writing, by means of a registered letter. No claim can be made, nor as an exception, in a court of law if the goods, for which the claim is submitted, have not been regularly paid.

Any claim concerning a single delivery of goods will not exonerate the buyer from his obligation to pick-up the remaining quantity of goods within the limit of the order.

19.3 - To pass safety information

The buyer is responsible towards the final user for the safety information shown on the sale documentation, concerning use limit, performances and product features.

19.4 - Validity and acceptance

The guarantee is valid if the CERTIFICATE OF GUARANTEE is sent, to C.I.M.A. S.p.A., with every part of it filled in, within 30 days from the date of purchase (referring to the date of the postmark).



DICHIARAZIONE DI CONFORMITÀ ai sensi della direttiva 98/37/CE del 22/06/98 e successive modificazioni				
DECLARATION OF CONFORMITY as directive: 98/37/CE - 22/06/98 and subsequent modifications		DECLARATION DE CONFORMITE selon la directive 98/37/CE - 22/06/98 et modifications ultérieures		
ÜBERREINSTIMMUNGS-ERKLÄRUNG It. Direktiven 98/37/CE - 22/06/98 und nachfolgenden Änderung		DECLARACION DE CONFORMIDAD con arreglo a la Directiva 98/37/CE - 22/06/98 y modificaciones siguientes		
CIMA s.p.a. 27040 MONTÙ BECCARIA (PV) - ITALY - Loc. Molino Quaroni				
DICHIARA SOTTO LA PROPRIA RESPONSABILITÀ CHE LA MACCHINA:	HERewith DECLARES, UNDER THEIR PERSONAL RESPONSABILITY, THAT THE FOLLOWING MACHINE:	DECLARONS SOUS NOTRE RESPONSABILITE QUE LA MACHINE DECRIE CI-APRES:	BESTÄTIGT HERMIT UNTER IHRER PERSÖNLICHEN VERANTWÖRTUNG, DASS DIE MASCHINE:	DECLARA BAJO LA PROPIA RESPONSABILIDA QUE LA MAQUINA:
SERIE, TIPO - MODEL, TYPE - SERIE, TYPE - MODEL, TYP - SERIE, TIPO:				
<input type="text"/>				
MATRICOLA - SERIAL - MATRICULE - SERIAL - MATRICULA NR.:				
<input type="text"/>				
E' conforme ai Requisiti essenziali di Sicurezza e di Tutela della Salute di cui alla Direttiva 98/37/CE del 22/06/98 e sue successive modificazioni. Per la verifica della Conformità di cui alle Direttive sopra menzionate, sono state consultate le seguenti: Norme armonizzate: EN 294 EN 349 EN 907.				
Conforms to the essential Safety regulation as well as the Health requirements as per European Economic Community Directive: 98/37/CE - 22/06/98 and subsequent modifications. For the verification of conformity as per above mentioned directives the following official EN norms have been consulted: Harmonized norms: EN 294 EN 349 EN 907.		Est conforme aux exigences de Sécurité et de Sauvegarde de la Santé dont à la Directive 98/37/CE - 22/06/98 et modification ultérieures. Pour vérifier la conformité aux directives susmentionnées, ont été prises en compte les normes suivantes: Normes harmonisées: EN 294 EN 349 EN 907.		
Stimmt mit den wesentlichen Requisiten der Sicherheitsvorschriften und der Gesundheitsvorsorge lt. EWG Direktive Nr. 98/37/CE - 22/06/98 und nachfolgenden Änderungsverein. Für die Überprüfung dieser Übereinstimmungs-Erklärung lt. obigen Direktiven sind folgende Normen konsultiert worden: Normen: EN 294 EN 349 EN 907.		Cumple con los requisitos esenciales de Seguridad y de Preservación de la Salud contenidos en la Directiva 98/37/CE - 22/06/98 y modificaciones siguientes. Para comprobar la conformidad a la que se refieren las Directivas anteriormente citadas, se han consultado las siguientes: Normas Armonizadas: EN 294 EN 349 EN 907.		
Responsabile della Sicurezza - The Security Official - Responsable Sécurité et Homologations - Der Sicherheits-Beamter - Responsable de la Seguridad				
Smeraldi Paolo				
Montù Beccaria (PV) Data, Date, Datum, Fecha: _____				

09102

1.1 - PUBLICATION IDENTIFICATION

The "OPERATION AND MAINTENANCE INSTRUCTIONS" manual is an integrative part of the sprayers. It is identified by a Publication No. located on the frontispiece, and through which the document can be identified, traced and/or subsequently referred to.

The information elements contained herein are updated as at the date of publication. C.I.M.A. S.p.A. reserves the right to modify its machines without notice, with the purpose of applying technical enhancements, and it declines all responsibility for possible omissions from the publication.

All rights are reserved. No parts of this book may be reproduced or utilized in any form or by any means, electronic or mechanical, including photocopying, recording, or by any information storage and retrieval system, without permission in writing by C.I.M.A. S.p.A.

1.2 - ATTACHED PUBLICATIONS

- Spare parts catalogue;
- "Low Volume - Instructions for sprayer adjustment"
- Distribution devices,
 - "Operation and maintenance instruction"
 - "Spare parts catalogue"

1.3 - PURPOSE OF PUBLICATION

All indications contained in this manual are aimed at the user of the sprayer.

The duration of the machine and its operation, the operator's safety and the respect for the environment are dependent upon scrupulous observance of the stated norms.

Before making use of the sprayer, the user must read, understand and abide by all regulations listed in this manual.

1.4 - REFERENCE TO REGULATIONS

This manual was set out conforming to the regulations contained in following documents:

- Attachment "I" to Directive 98/37/CE and subsequent modifications (letters "b", "c" of point 1.1.2 and point 1.7.4);
- UNI EN 907 - 1998 and to all the documents in it quoted.

1.5 - USING THE MANUAL

Read every part of this manual, paying attention to the **WARNING** and **DANGER** indications both on the text and on the machine or on components.

All operations suggested by the manual will have to be followed with the utmost care and only after having understood the negative consequences of improper usage.

The following “symbols “ are used within the text in order to highlight and visually identify the importance of the various types of information:



Indicates important additional information.



Non observance can result in permanent damage to the sprayer.



Highlights possibly dangerous situations to people.

The manual, with relevant attachments and possible integrating issues, must be kept with the utmost care and must always be complete, integer and legible in every part. Should it be mislaid it is imperative to immediately request a duplicate from C.I.M.A. S.p.A. Should the decals originally applied on the machine be mislaid, damaged or become incomprehensible, they should be promptly replaced.

For every type of distribution device (Head) delivered with the sprayer, a specific user and maintenance manual is attached. All the head manuals must always accompany the one of the machine.



- The manual must always be kept for the sprayer's whole operational life.
- Any modification received must be permanently inserted in this publication.
- The manual must be ceded with the sprayer should this be sold.

1.6 - UPDATES

Possible updates that C.I.M.A. S.p.A. will provide the owner of the sprayer will be accompanied by instructions to insert in this publication.

Should the machine be sold, the owner must inform the new purchaser that he should notify C.I.M.A S.p.A. of his address in order to receive possible future integrating issues and/or updates.

Sprayer model	Observed equivalent average level L qA - dB(A)
BLITZ 45T	92,0 ± 0,2
BLITZ 50T	93,0 ± 0,2
BLITZ 55T	95,4 ± 0,2
BLITZ 55TS	95,4 ± 0,2
BLITZ 55TE	95,4 ± 0,2

BLITZ2009

16.2 - WIRING DIAGRAM

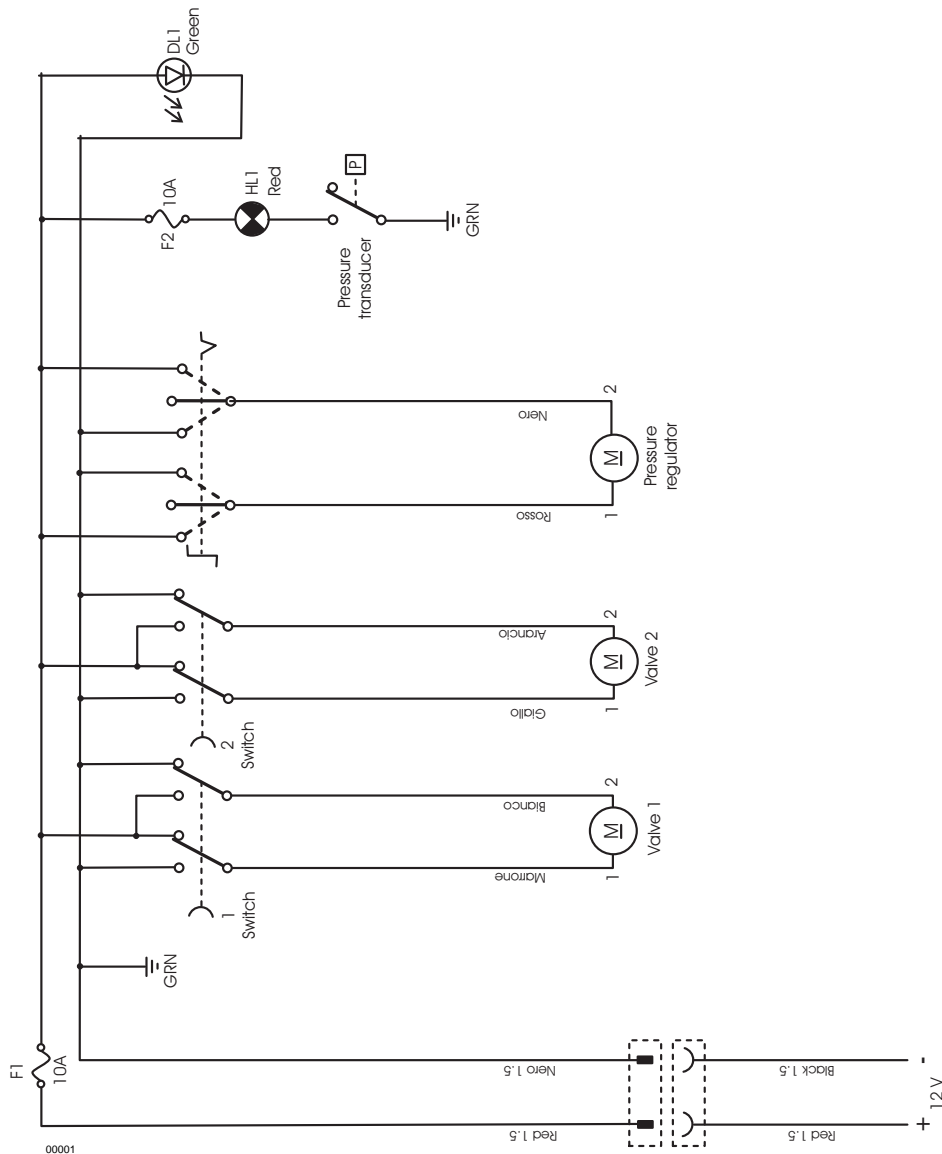

2.1 - TERMINOLOGY

The terms FRONT, REAR, RIGHT and LEFT utilised in this publication refer to the sprayer as seen by an operator from behind the operative unit along the drive line and facing it: **the rear part** of the machine is that closest to the operator, and is where the distribution device (Head) is mounted - and **the front part** is the one that gets attached to the tractor.

2.2 - ABBREVIATIONS

cm	centimeter
g	grams
h	hour
ha	hectare
ha/h	hectares per hour
l	litre
l/h	litres per hour
l/min.	litres per minute
kg	kilogram
kg/cm ²	kilograms per square centimetre (atmosphere)
km	kilometre
km/h	kilometres per hour
Lm	width in metres
m	metre
Mesh	N° of meshes per liner inch
Micron	1/1000 of millimetre
mm	millimetre
PTO	Power take-off
RPM	revs per minute
s	second

2.3 - DECALS

The safety and use/maintenance decals are applied to the machine are described in the following paragraph.



Every decal is marked with its part number, in case it needs to be replaced.

Safety

- 1 - 95001 - STOP THE ENGINE AND REMOVE THE KEY FROM THE TRACTOR'S CONTROL PANEL BEFORE CARRYING OUT ALL MAINTENANCE OR REPAIR OPERATIONS
- Positioned on the left side of the frame, near the control taps.
- 2 - 95004 - DANGER OF CONTAMINATION BY CONTACT OR POISONOUS PRODUCTS INHALATION
- Positioned above the main tank, in the forward part, next to the filler spoutes.

- 3 - 95005 - **DANGER, PARTS IN MOTION. BEFORE REMOVING PROTECTION GUARDS, STOP THE TRACTOR, REMOVE THE KEY FROM THE TRACTOR'S CONTROL PANEL AND ENSURE THAT ALL MOVING PARTS HAVE STOPPED**
- Positioned on the tank front section, behind the fan casing.
- 4 - 95015 - **BEFORE UTILISING THE RELEASE DEVICE, STOP THE TRACTOR, REMOVE THE KEY FROM THE TRACTOR'S CONTROL PANEL AND ENSURE THAT THE FAN HAS STOPPED**
- Positioned on the removable cover protecting the access to the release device.
- 5 - 95010 - **MAXIMUM OPERATING SPEED OF THE DRIVE OUTLET (PTO): 540 RPM**
- Positioned near the drive outlet.
- 6 - 95007 - **DANGER OF SPRAYS: KEEP AT A SAFE DISTANCE**
- Positioned on the frame rear section, on the left side.
- 7 - 95006 - **WARNING: CONSULT THE USER AND MAINTENANCE MANUAL BEFORE USING OR INTERVENING ON THE MACHINE**
- Positioned on the left-hand side of the tank, in the forward part of this one.
- 8 - 95009 - **DANGER: GLOVES MUST BE USED TO EMPTY THE TANK**
- Positioned on the unit's left side, near the draining cock.
- 9 - 95077 - **IT IS FORBIDDEN TO ENTER INTO THE TANK!**
- Positioned on the tank left side, near the main filler.
- 10 - 95008 - **CAUTION: NO HAND-WASHING TANK**
- Positioned on the protection case of the mechanical parts, under the hand-washing tank: this is visible when this tank has been removed.

Use and maintenance

- 11 - 95059 - **HOOKING POINT FOR THE LIFTING OF THE MACHINE, N°4**
- Positioned on the front side of the sprayer and on the distribution devices' rear fastening bracket.
- 12 - 95079 - **CHECK THE OIL LEVEL EVERY 8 HOURS: FAN SHAFT BEARINGS**
- Positioned on forward of the chassis, near the oil level dipstick.
- 13 - 95054 - **GREASE EVERY 200 HOURS: FAN BELT-TENSIONER SUPPORT, FREE WHEEL, WHEEL HUBS, DRAWBAR ARTICULATED JOINT AND SUPPORT FOOT**
- Positioned on the right front side frame
- Positioned in the front section, near the Power Takeoff.
- Positioned on the wheel
- Positioned on the steering drawbar (for the versions on which it is foreseen).
- Positioned on the support foot.
- 14 - 95057 - **HAND WASHING TANK TAP**
- Positioned on the left-hand side of the tank, next to the tap.
- 15 - 95065 - **WARNING: NEVER OPERATE THE SPRAYER WITHOUT LIQUID IN THE TANK**
- Positioned on the tank, in the left section.
- 16 - 95060 - **INDICATION OF THE WHEELS OPERATING PRESSURE**
95056 - Positioned on the side frame, near the wheels.
- 17 - 95074 - **INDICATION ON THE OPERATION OF THE 3-WAY TAP (P3)**
- Positioned on the frame right side, next to the tap.
- 18 - 95094 - **INDICATION ON THE OPERATION OF THE 3-WAY TAP (P11)**
- Positioned on the frame right side, near the additional pump (P10) (for the version where foreseen).
- 19 - 95083 - **INDICATIONS ON THE OPERATION OF THE PLANT-WASHING TAP (P15)**
- Positioned on the frame left side, near the 3-way tap (for the versions where foreseen).

E.P.A. versions

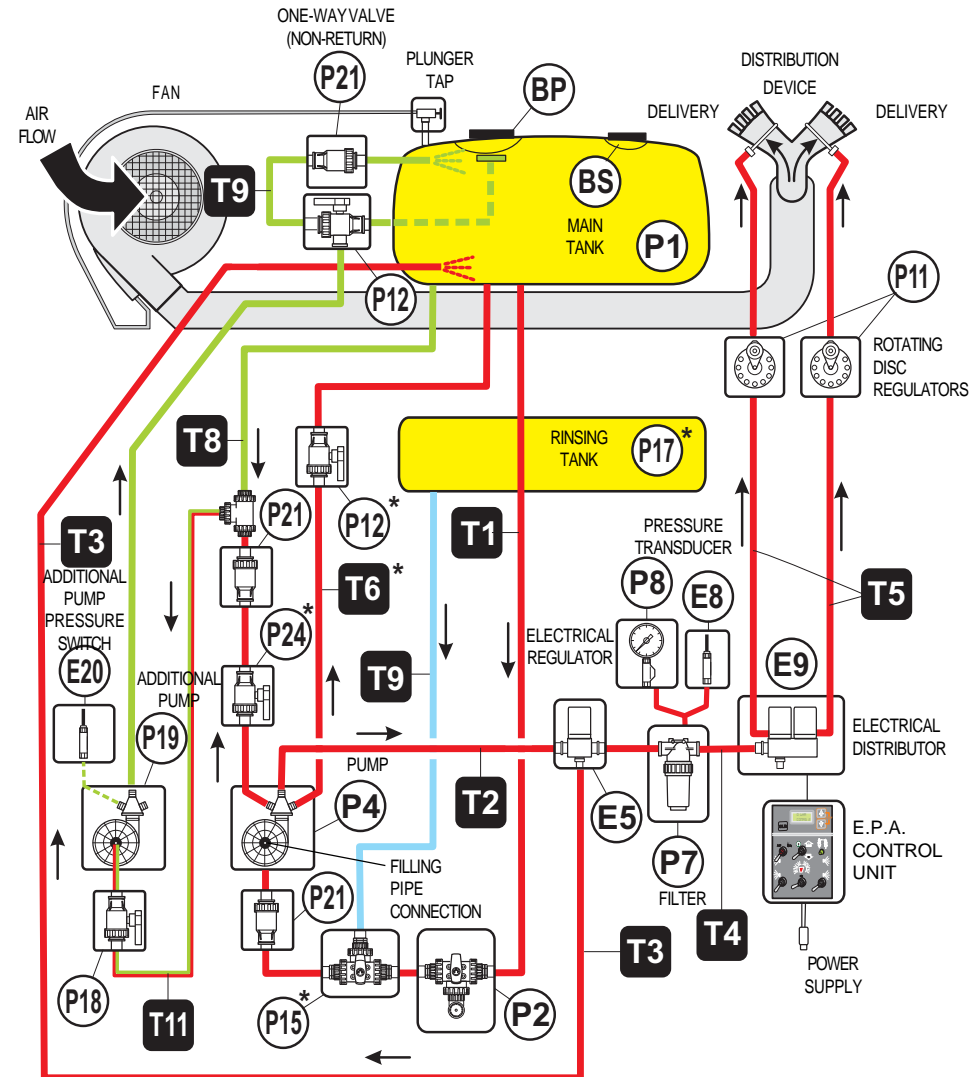

* For the version in which it is envisaged

00931

Version with additional agitation pump

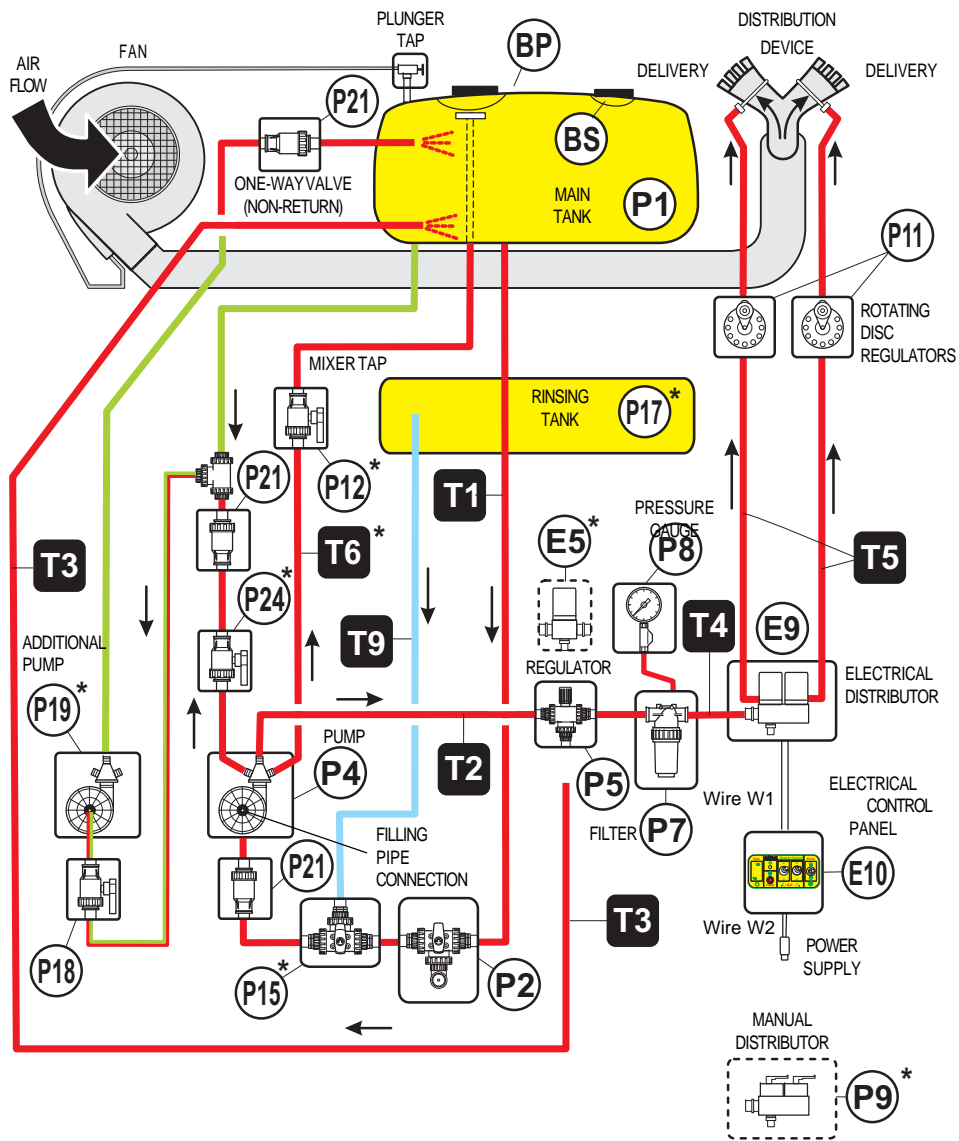

* For the version in which it is envisaged

00637_2P

Positioning of the safety, use and maintenance decals

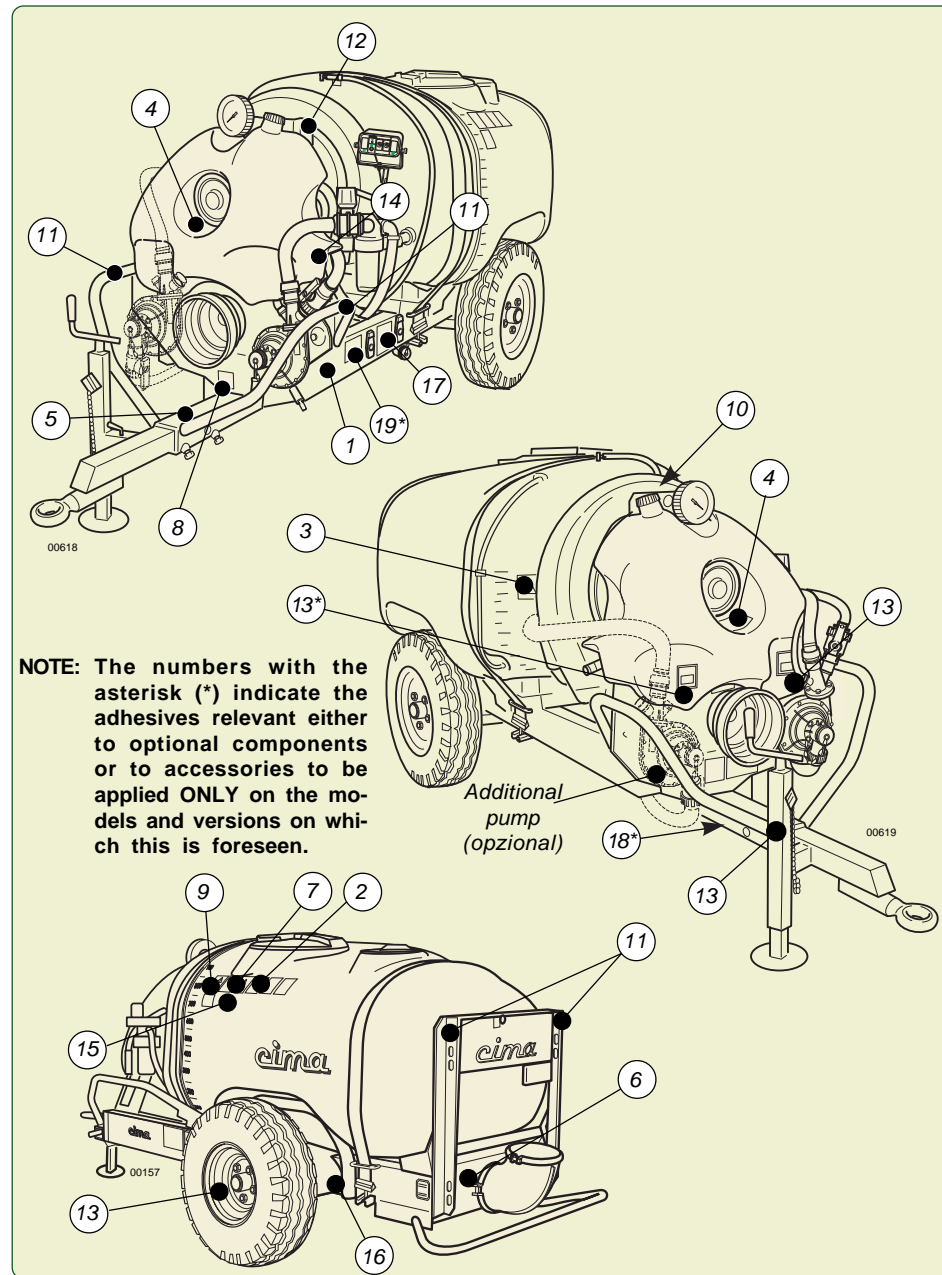

* Safety decals

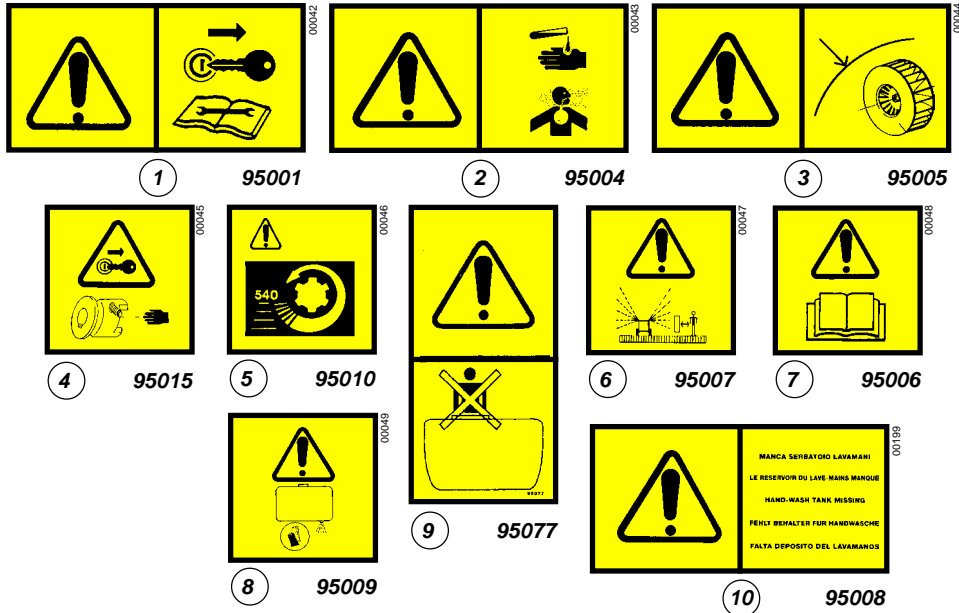

* Use and maintenance decals

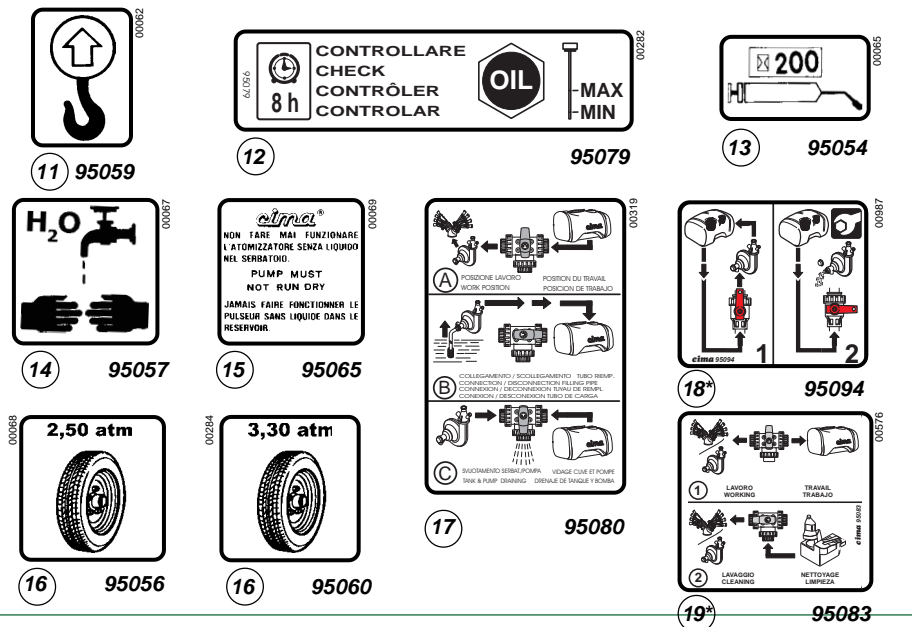

16 INTEGRATIVE DIAGRAMS 16

16.1 - HYDRO-PNEUMATIC DIAGRAM

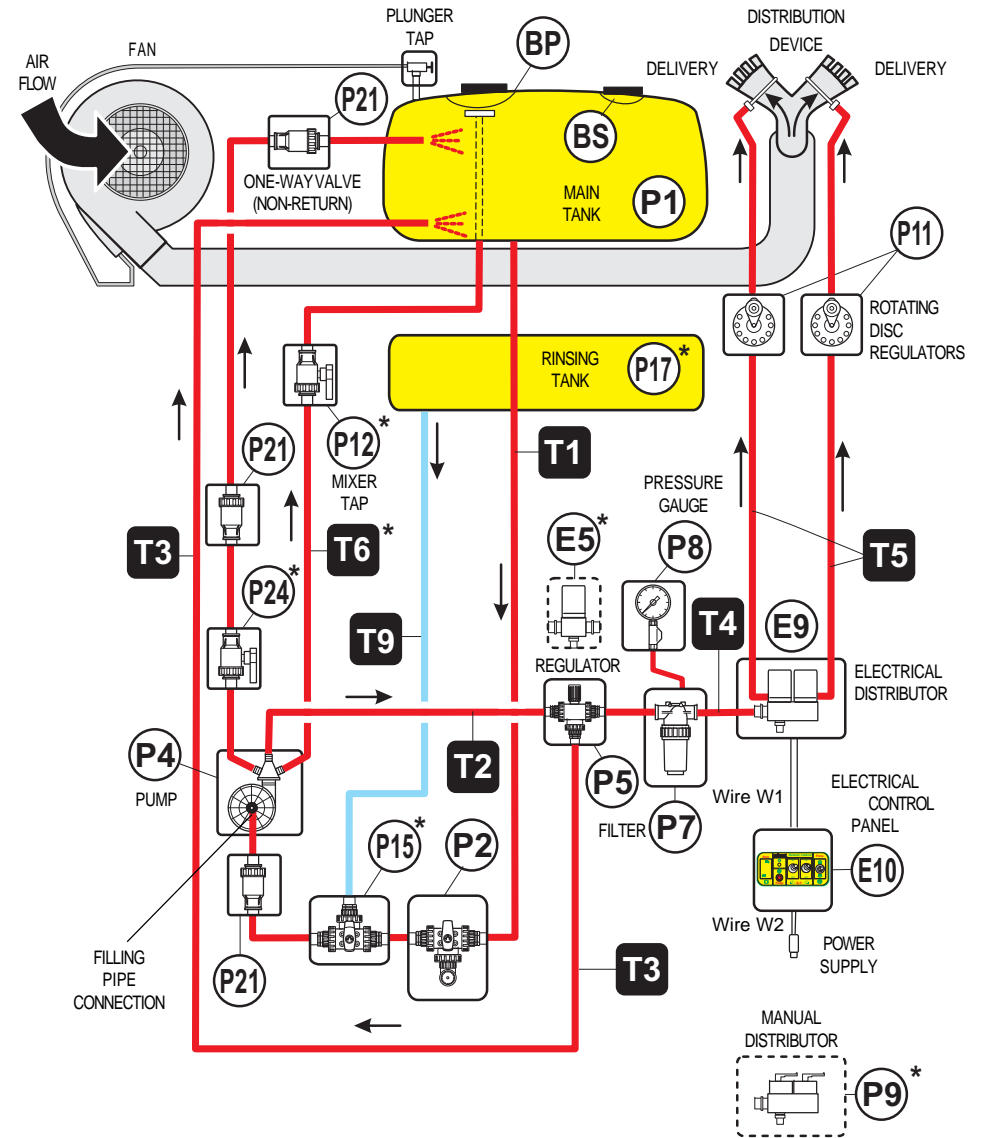

* For the version in which it is envisaged

15.6 - TANK REMOVAL OR REPLACEMENT



This operation has to be carried out by a C.I.M.A. service point



The operation has to be carried out by complete absence of liquid residuals both inside the tank and in the hydraulic circuit.

1. Make the tank free from all the hydraulic and pneumatic connections.
2. Loosen the screw (4), for tensioning the tank fastening belt.
3. Remove the split pin (3).
4. Unscrew the belt end (2), in order to make the tank free; carry out the same operation for the second belt (1).
5. Lift the tank and remove it from the frame.

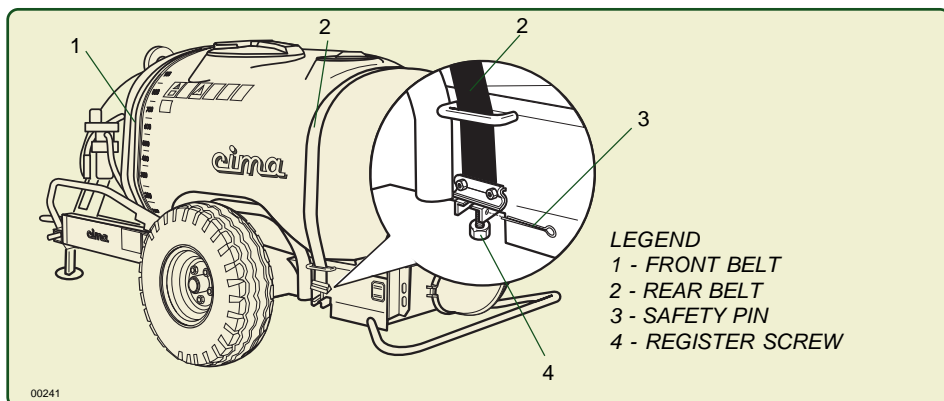

Before reassembling the main tank check the integrity of the rubber supports glued on the frame; if damaged or particularly worn replace them.

6. Position the tank on the frame.
7. Reposition the anchorage belts in their own seats.
8. Screw the regulation nut on each belt so that they are tight enough to firmly secure the tank to the frame.
9. Replace both the safety pins.



The adjustment of the belts takes place during the first 3÷4 hours of use of the atomizer; after this period check and restore the correct tension of the belts so that the perfect block of the main tank to the frame will be guaranteed, this way preventing any damages or breakups of the tank itself.



Before every treatment, check the tension of the tank anchorage belts.

3.1 - MACHINE IDENTIFICATION

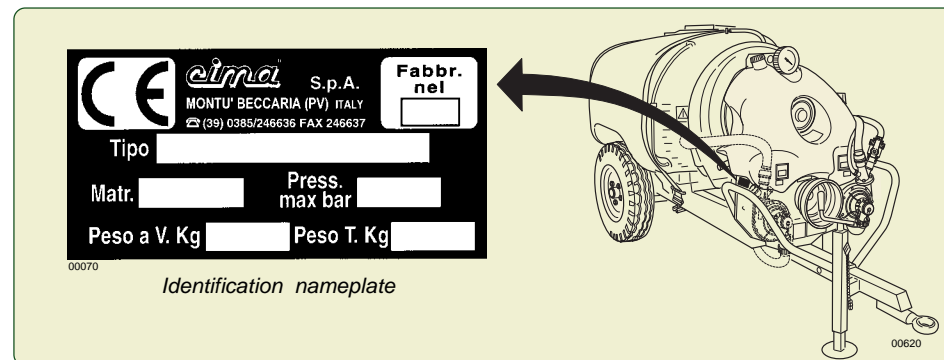

3.2 - TECHNICAL ASSISTANCE

C.I.M.A. S.p.A. is at the complete disposal of customers for any type of intervention. The names and addresses of its service network, both in Italy and in foreign countries, can be requested from:

C.I.M.A. S.p.A. - 27040 Montù Beccaria - Loc. Molino Quaroni (PV) - ITALIA
 tel. +39-0385-246636 - fax +39-0385-246637
 e.mail service@cima.it

3.3 - SAFETY NOTICES

All the preparation, use, maintenance, moving and transporting operations must be carried out only after having acquired a perfect knowledge of the regulations contained in this publication and the ability to appropriately interpret the symbols of the decals applied to the machine.



IT IS FORBIDDEN TO UTILISE THE SPRAYER FOR PURPOSES OTHER THAN FOR ITS INTENDED USE, SINCE IT WAS MANUFACTURED ONLY FOR SPRAYING AGRICULTURAL CROPS WITH ANTI-PARASITIC PRODUCTS.

It is necessary to scrupulously abide by the following general norms:

- always stop the tractor's engine before carrying out any operation on the sprayer;
- check that the weight and power of the tractor are compatible with the sprayer to be used;
- before utilisation, check the correct tightening and securing of the machine's various components, paying particular attention to the safety protections and to the moving parts;
- only utilise protected cardan shafts provided with CE conformity certification.
 Carry out the assembly only if the drive outlets of both tractor and sprayer are equipped with the protection counter-guard;
- check that the cardan shaft is blocked by the appropriate anti-rotation chains;
- keep people and animals away from the machine before starting it up;
- don't wear articles of clothing that might get caught in moving parts;
- keep to a low speed while negotiating bumps or crossing ditches.



- All maintenance and repair operations must be carried out only after having rinsed the tank and flushed the system.
- Before operating within the tank it is necessary to wash it thoroughly with clean water.
- It is forbidden to perform welding operations if ammonium salts were previously used.
- It is forbidden to use the machine within a potentially explosive environment.
- The application of paints and/or solvents, the washing of closed environments and machinery as well as the utilisation of the air flow for purposes other than those expressly concerning the spraying of agro-chemicals is not permitted.
- It is forbidden to enter the tank.

3.4 - SAFETY SYSTEMS

All machine moving parts are suitably protected by guards and highlighted through the use of warning decals.



- It is forbidden to use the machine with these guards removed.
- Before removing the protection, stop the tractor's engine and remove the key from the control panel.

The pictures illustrate the machine's guarded parts:

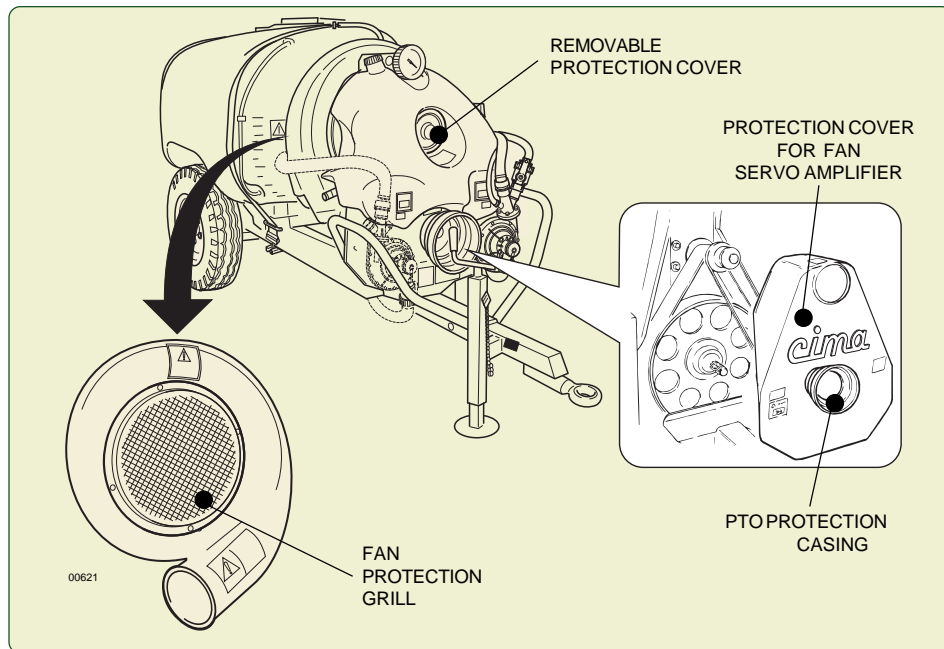

15.5. - CHECK HYDRAULIC DELIVERY



TESTING OF HYDRAULIC DELIVERY MUST BE MADE WITH THE SPRAYER ON A FLAT SURFACE. THE PROOF IS IN THE DETECTION OF TIME TO PROVIDE A KNOWN QUANTITY CONTENT OF LIQUID IN TANK

1. Disengage the fan (for versions where it is foreseen): see Paragraph 8.1.a.
2. Close the taps of the 2-way distributor:
 - a. if manual (P9), the levers are to be lowered (horizontally positioned);
 - b. if electric, position to "OFF" the quick-break switches (E10).
3. Fill the tank with about 250 liters of clean water (**USED AS REFERENCE THE MARK OF LEVEL INDICATOR ON THE TANK** - see Paragraphs 8.2/8.3).
4. Engage the fan (for versions where it is foreseen): see Paragraph 8.1.b.



The claimed performance is obtained with the PTO at 540 rpm. and with the fan running .

For correct verification result this condition MUST ALWAYS BE RESPECTED.

5. Bring the PTO to 540 rpm rotation rate.
6. Open the taps of the 2-way distributor:
 - a. if manual (P9), the levers are to be raised (vertically positioned);
 - b. if electric, position to "ON" the quick-break switches (E10).
7. Regulate the operating pressure, by acting on the pressure regulator (P5) (or electric E5) with the distributor, hand (P9) or electric (E9), open (DISTRIBUTION) and regulate the position of calibration disc (P11) in accord to "Delivery chart" relating to the sprayhead used.
8. Close the taps of the 2-way distributor:
 - a. if manual (P9), the levers are to be lowered (horizontally positioned);
 - b. if electric, position to "OFF" the quick-break switches (E10).
9. Add water to the tank until you reach the mark of 300 liters (reference).
10. Add additional 25 liters of water to the tank, the quantity required for the verification flow, using a graduated container or by weighing the amount payable (1liter = 1 kg).
11. Open the taps of the 2-way distributor (manual or electric) to start delivery.
12. Continue the delivery until the water reaches the mark 300 liters on the level indicator.



NOTED THE TIME ELAPSED BETWEEN THE RELEASE DELIVERY AND THE ACHIEVEMENT OF MARK 300 LITERS.

13. Apply the formula:
$$Q = \left(\frac{60}{t} \right) \times 25$$
 where: **Q**, is the hourly delivery detected (lt./h);
t, is the time measured in minutes and seconds (centesimal)

TESTING IS CONSIDERED WITH POSITIVE RESULTS (machine properly calibrated) WHEN THE VALUE CALCULATED "Q" IS INDICATED ON THE "DELIVERY CHART" WITH A TOLERANCE OF ± 2.5%.

In case of different values to verify the efficiency of the pipe, the fittings, the pressure gauge and the proper positioning of the calibration discs (P11), if necessary replace the damaged or defective, and the test repeated.

15.4 - INSPECTION AND CLEANING PUMP FILTER



The pump is provided by the suction side of a filter to prevent the accidental entry of foreign bodies in the pump body, such a possibility does not constitute a hazard and can only cause damage to the impeller shown by a drop in pressure reported by gauge..

The clogging of the filter pump causing an immediate lowering of pressure delivery. If necessary check the cleanliness of the filter:

1. Position the lever of the three-way cock (P2) in position "B".
2. For the versions fitted with spray-line rinsing tank position the lever of cock (P24) in position "c".
3. Unscrew the plug (1) and eventually remove the foreign body present in to the filter.
4. If necessary, unscrew the nuts (2) and remove the filter (4), to clean completely.
5. Replace the filter by paying attention to the conditions and the proper placement of the O.Ring (5).
6. Close the screw plug (1).
7. For the versions fitted with spray-line rinsing tank position the lever of the cock (P24) in position "a".
8. Position the lever of the three-way cock (P2) in position "A" - WORKING INSPECTION AND CLEANING PUMP FILTER

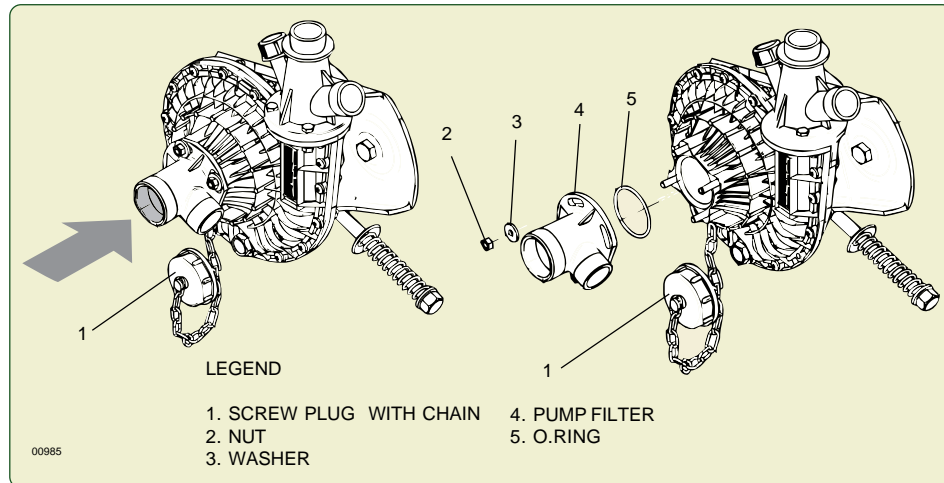

Additional agitation pump

1. Close the cock (P18): position "c".
2. Unscrew the plug (1) and eventually remove the foreign body present in to the filter.
3. If necessary, unscrew the nuts (2) and remove the filter (4), to clean completely.
4. Replace the filter by paying attention to the conditions and the proper placement of the O.Ring (5).
5. Close the screw plug (1).
6. Open the cock (P18): position "a".



THE OWNER AND/OR THE OPERATOR OF THE SPRAYER ARE NOT PERMITTED TO MODIFY THE STRUCTURE OR THE SPECIFIC OPERATION OF THE SPRAYER ITSELF. ANY REPAIRING INTERVENTION HAS TO BE CARRIED OUT EITHER AT THE DEALERS' OR AT THE C.I.M.A. S.p.A. AUTHORIZED WORKSHOPS, OTHERWISE ANY KIND OF WARRANTY IMMEDIATELY CEASES AND C.I.M.A. S.p.A. IS CLEARED OF ANY CONSEQUENT AND/OR IMPLIED RESPONSIBILITY.

3.5 - HANDLING OF AGRO-CHEMICALS

The **operator** could become contaminated due to accidental spray, contact or inhalation of products or crop-spraying mixtures.

The **environment** could become polluted by mixture over-spills, puncturing of containers, uncontrolled storage of used and unwashed containers or spillage into waterworks.

In order to avoid these risks the preparation and filling operations must be carried out in suitably appointed and adequately equipped sites.

3.5.1 - Storage

Fixed / stationary: the site used must be well ventilated and secured by lockable doors in order to prevent even accidental access by children or unauthorised persons.

Mobile: the carrier equipment must be properly locked and kept under conditions whereby access by children or unauthorised persons can be prevented during the absence of the operator. All full or partially utilised containers must be secured against tipping, falling or breakage during transportation. Both types of storage must:

- have a suitable container for the storing of empty packaging materials should a specific storage area not be available;
- have a clean water supply readily available for washing, by means of a specific container or through connection to the waterworks system;
- have the use of fire extinguishers, should flammable products and substances be stored.



- All packages, whether whole or partially utilised, must be stored in their original packing and with the warning instructions clearly displayed and legible.
- The storage indications must always be scrupulously adhered to, as well as their utilisation and possible disposal as suggested on the product's original packaging.

3.5.2 - Specific equipment

The site at which the preparation and filling out will take place must provide for:

- all the equipment necessary to the precise measuring of both the water quantity and the dose of product to be mixed in the tank at every filling;
- all the equipment and means useful to the preparation of the mixture and for the cleaning of the operator in case of contamination;
- all tools necessary to facilitate the direct introduction of the agro-chemicals in the tank;
- the allocation of clothing and specific equipment in order to avoid contamination by contact or inhalation during the whole operative phase of the intervention;
- the availability of proper equipment able to stop the uncontrolled spilling and flowing of the mixture;
- a retaining valve on the feed pipe when the filling of the tank takes place directly from the waterworks system.

3.5.3 - Disposal of empty containers and agro-chemicals residues

Agro-chemicals are classified as "special" waste and their disposal must take place separately from "urban" wastes.



Empty packaging and contaminated containers to be done away with cannot be dispersed, burned or buried.

The washing water for the cisterns and the tools utilised for the preparation of mixtures cannot be emptied on the ground, spilled into the sewage system or in waterways and rivers.

The disposal of special wastes is regulated by specific norms. In order to perform this operation it is necessary to obtain the relevant information from the Local Offices specifically appointed to rule on this subject. The non compliance with these regulations can cause considerable damage to persons and animals as well as polluting the environment.

3.5.4 - Personal means of protection

The toxicity of agro-chemicals forces persons working with them to wear adequate protective clothing and accessories in order to avoid risks of contamination by contact or inhalation.

In each of the following work stages:

- filling of tanks and adding of the agro-chemical,
- dusting and spraying,
- adjusting of the sprayer,
- emptying and cleaning of the tank,
- replacement of the agro-chemical,
- maintenance interventions,

it is necessary to wear personal protection clothing and accessories.

The following must be worn:

- Polyethylene or polyvinyl gloves.
- Full, waterproof cotton overalls, in order to guarantee transpiration, fitted with polypropylene side flaps.



- In commerce, one-time 'tyvek' overalls are available which, after use (see picture), must be disposed of according to the modalities applicable to toxic waste.
- A protective half-mask in polychloroprene rubber with 1 or 2 filters. Filters for gases and organic fumes, of European A1-class vapours, are envisaged and these can be combined with anti-dust models of P1 European class, for harmful mists and powders, or P2, for harmful and toxic mists and powders.



The filters must be replaced:

- when the smell/taste of agro-chemicals can be detected, and that of active A1-class carbons;
 - when difficulty in breathing is experienced for the anti-dust filters of class P1 and P2.
- In any case it is necessary to make use of all personal means of protection as suggested by the manufacturers.**

15.2. - REPLACEMENT OF ELECTRICAL PANEL'S FUSES



Stop the engine and remove the ignition key from the tractor's control panel.

1. Replace the faulty fuse and screw back the cover.

* **Fuse: 10 A, delayed.**



ANY OTHER INTERVENTION HAS TO BE CARRIED OUT AT A C.I.M.A. CUSTOMERS' SERVICING CENTER.

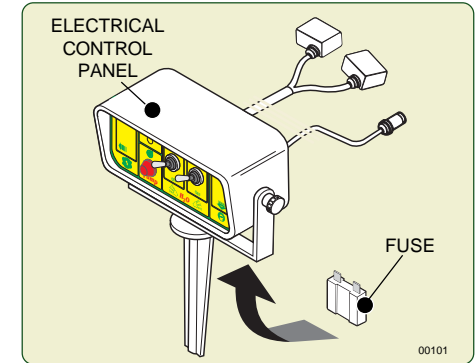

15.3. - PRESSURE GAUGE REPLACEMENT



Stop the motor and remove the starting key from the tractor control panel.

1. Unscrew and remove the defective pressure gauge ;
2. Replace the pressure gauge.

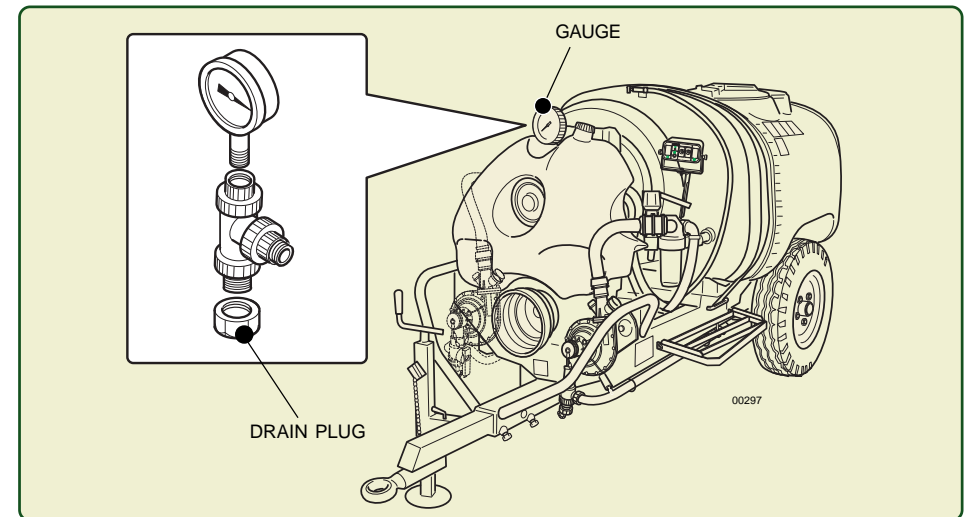

ANY OTHER INTERVENTION HAS TO BE CARRIED OUT AT A C.I.M.A. CUSTOMERS' SERVICING CENTER.



THE OWNER AND/OR THE OPERATOR OF THE SPRAYER ARE NOT PERMITTED TO MODIFY THE STRUCTURE OR THE SPECIFIC OPERATION OF THE SPRAYER ITSELF. ANY REPAIRING INTERVENTION HAS TO BE CARRIED OUT EITHER AT THE DEALERS' OR AT THE C.I.M.A. S.p.A. AUTHORIZED WORKSHOPS, OTHERWISE ANY KIND OF WARRANTY IMMEDIATELY CEASES AND C.I.M.A. S.p.A. IS CLEARED OF ANY CONSEQUENT AND/OR IMPLIED RESPONSIBILITY.

15.1 - REPLACEMENT OF PUMP CONTROL BELT



Stop the engine and remove the key from the tractor's control panel.

1. Remove hands-washing tank.
2. Remove the fan assembly protection, by unscrewing the screw fastening it to the frame.
3. Completely unscrew the tightener spring adjusting screw: the pump support plate will so freely turn.
4. Remove the worn out belt, by getting it first loose from the pump pulley and then from the upper control pulley.
5. Insert the belt first into the race of the upper pulley and then into the race of the pump pulley.
6. Reinstall the spring of the belt-tensioner according to the suggested tensioning conditions.
7. Mount back the fan assembly protection casing.
8. Install hands-washing tank.

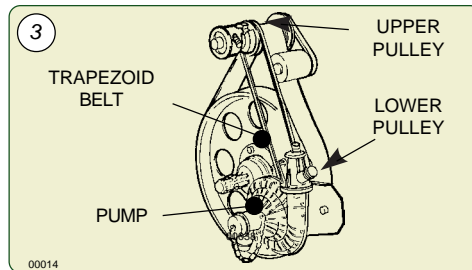
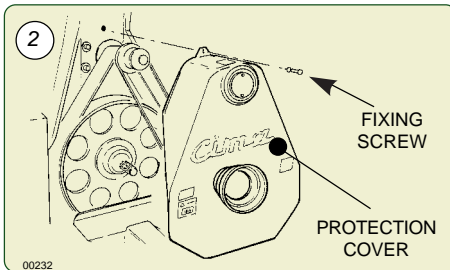
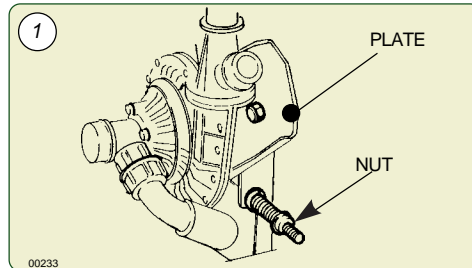

Carefully tighten the screws that were undone during the belt replacement.

The pictures indicate the position of the main components of the sprayer.

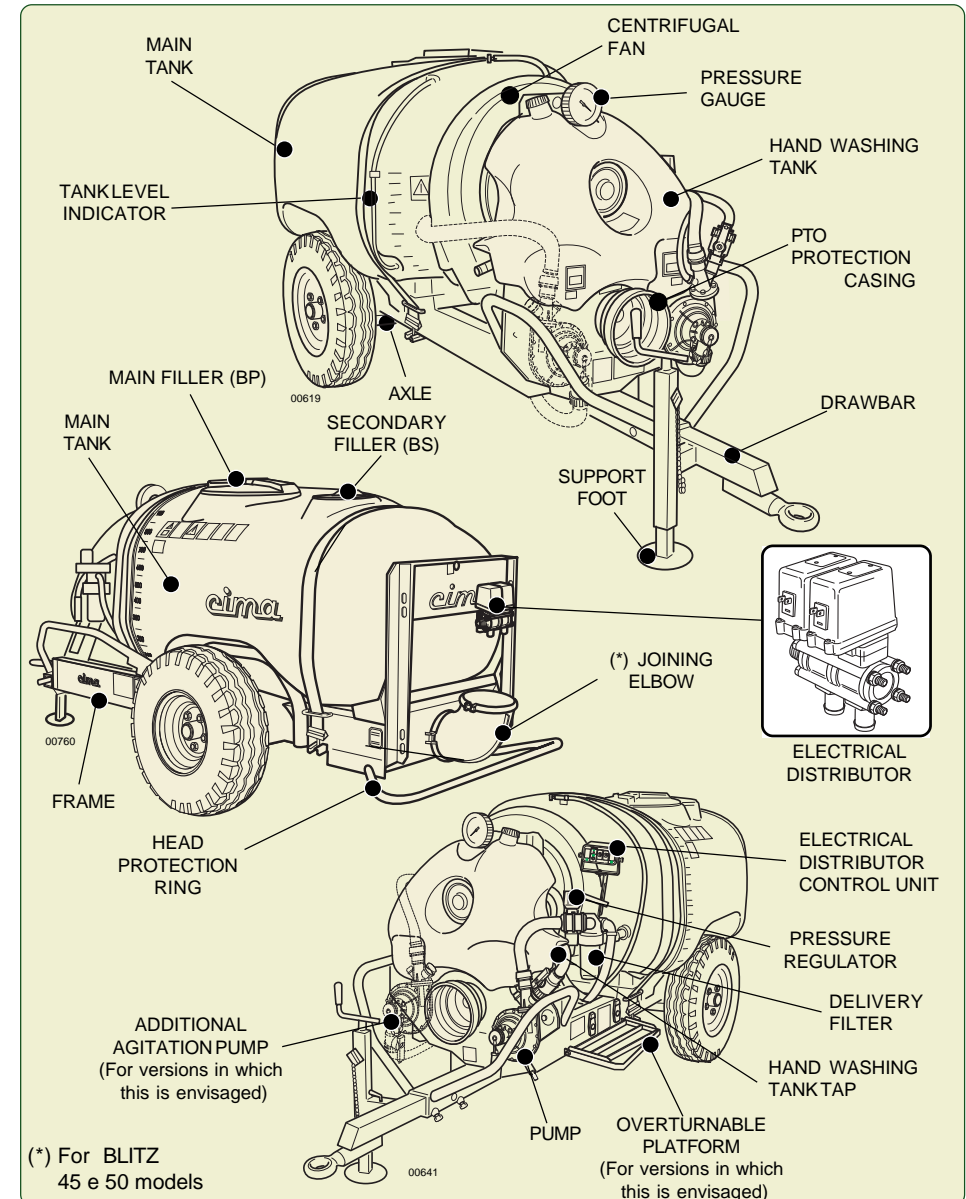

4.1 FRAME WITH DRAWBAR

DRAWBAR WITH STANDARD TRAIL EYE. It is inserted in the frame front section; its position is regulated by means of the insertion of a through screw, provided with a self-locking screw nut. The drawbar is locked by means of the two lateral screws, foreseen for this purpose

- Adjustable in **height** for 13 cm (16 cm for the 1500-2000 litres BLITZ 55 models).
- Adjustable in **length**, with displacements of 8 – 16 – 24 – 32 cm.



After every regulation, carefully tighten the two fastening screws.

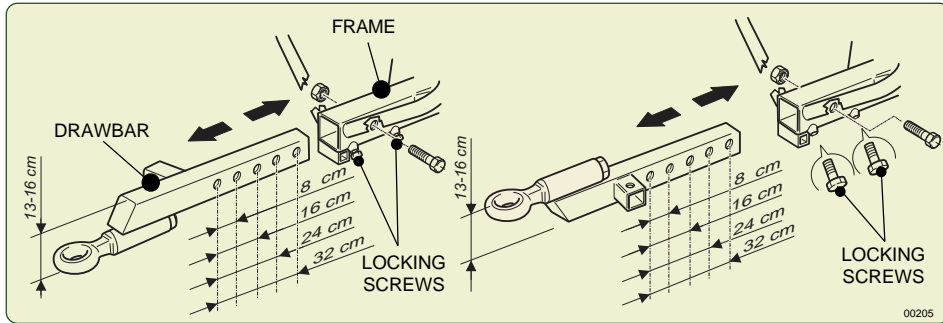

BRACKET DRAWBAR (for the versions on which it is foreseen). It's inserted in the frame front section; its position is regulated by means of the insertion of a through screw, provided with a self-locking screw nut. The drawbar is locked by means of the two lateral screws.

- Adjustable in **height** for 13 cm (16 cm for the 1500-2000 litres BLITZ 55 models).
- Adjustable in **length**, with displacements of 8 and 16 cm.



After every regulation, carefully tighten the two fastening screws.

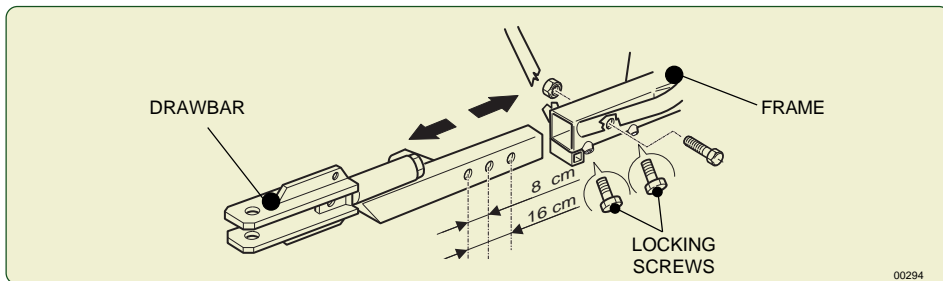

J. FAULT: No spraying action delivered: totally or only on the one side of the distribution device

1. CAUSE: Manual distributor (P8) taps dirty or clogged, or pump suction piping clogged by hardened product deposits.
REMEDY: Clean.
- 1b. CAUSE: Electrical distributor (E9) taps blocked by incrustations in the closed position.
REMEDY: Remove the cover, act on the opening/closing control rod.
Clean the distributor.
2. CAUSE: Fuses of the electrical control panel (E10)
REMEDY: Replace the fuses.
- 3b. CAUSE: Power cable W1 of the electrical panel interrupted or oxidized connectors of the electric distributor (E9)
REMEDY: Connect and possibly replace the defective components correctly.
4. CAUSE: Defective electrical connections.
REMEDY: Address a C.I.M.A. point of "Sale and Service".
5. CAUSE: Pump defective (only in case total delivery missing).
REMEDY: Address a C.I.M.A. point of "Sale and Service".
6. CAUSE: Broken pump belt.
REMEDY: Replace the belt (See Paragraph 15.1).



THE CAUSES AND REMEDIES FOR THE FAULTS CONCERNING THE DELIVERY OF THE SPRAYING BY ONE OR MORE DIFFUSERS ARE INDICATED IN THE USE AND MAINTENANCE MANUAL OF EACH SPRAYHEAD.

K. FAULT: Anomalous consumption of oil of the fan support.

1. CAUSE: Oil drain plug not adequately closed.
REMEDY: Check, reposition and adequately close then handle the filling up of the oil level.
2. CAUSE: Damaged flexible oil waste pipe or damaged pipe fixing clamp.
REMEDY: Check, adequately then handle the filling up of the oil level. Replace the damaged parts: Address a C.I.M.A. point of "Sale and Service".
3. CAUSE: Drawings from the support mechanical seals.
REMEDY: Address a C.I.M.A. point of "Sale and Service".

L. FAULT: Noisiness (ticking) coming from the upper part of the mechanical drive at low runnings, above all when slowing down.

2. CAUSE: Consumption of the damping elements of the fan release.
REMEDY: Eventually have it replaced; address a C.I.M.A. point of "Sale and Service".

M. FAULT: Noisiness (ticking) coming from the lower part of the mechanical drive at low runnings, above all when slowing down.

1. CAUSE: Lack of grease in the multiplier free wheel.
REMEDY: Grease the free wheel.

3. CAUSE: Wrong positioning of the circuit-washer faucet (P15) with the circuit-washer tank empty.
REMEDY: Position the lever of the faucet correctly (P15 - pos. 1") and fill the circuit-washer tank.
4. CAUSE: Lack of seal of the O-Ring gasket of the pump suction connection (cone).
REMEDY: check the correct assembling and the efficiency of the O-Ring gasket, if necessary replace the gasket.

E. FAULT: Vibrations of fan unit.

1. CAUSE: Dirty fan.
REMEDY: Wash. (It is advisable to refer a C.I.M.A. point of "Sale and Service".
2. CAUSE: The tractor and of the atomizer PTOs are not lined up or their position determines the overcoming of the maximum work angle of the drive cardan shaft.
REMEDY: Position the 2 PTOs so that the drive cardan shaft can work correctly (see Paragraph 5.2.1).

F. FAULT: Anomalous and continuous noisiness together with vibrations of the fan group.

1. CAUSE: Breaking of the fan shaft bearings.
REMEDY: Address a C.I.M.A. point of "Sale and Service".
2. CAUSE: Interference fan - case.
REMEDY: Address a C.I.M.A. point of "Sale and Service".

G. FAULT: Intermittent operation of the whole distribution device

1. CAUSE: Lack of seal of the hydraulic circuit that goes from the tank (T1) suction pipes to the electrovalves (E7) or hand distributor (P8).
REMEDY: Carefully inspect all the points at which suction of air can take place, including as well those at which no liquid seepage is detected. Check the proper tightening of ring nuts, fittings and clamps. Check the efficiency of the sealers and the integrity of the piping. Reinstate the efficiency and replace parts that might have been found to be defective.

H. FAULT: Intermittent spraying only on the one side of the distribution device

1. CAUSE: Faulty sealing of the hydraulic circuit going from the manual (P8) or electrical (E7) distributor to the distribution point involved.
REMEDY: As per point G.1.

I. FAULT: No spraying action delivered: totally.

1. CAUSE: Clogging up of the grill/filter on the pump, of the pump suction inside the tank or suction pipes of pump clogged up with deposits of hardened plant protection product.
REMEDY: Clean.

SUPPORT FOOT with crank regulation.



ALWAYS use the adjustable support foot, in order to stabilize the sprayer when it isn't hitched to the tractor.

The adjustable support foot can be fastened to the sprayer in three different positions, according with the different operative requirements:

Position A - applied to the drawbar, it assures the necessary stability to the sprayer, when it isn't hitched to the tractor.

Position B - vertically applied to the frame, it allows to regulate the length and to modify the drawbar height, after the sprayers has been linked to the tractor.



Work ONLY when the sprayer is linked to the tractor : otherwise the sprayer stability is not guaranteed.

Posizione C - horizontally applied to the frame, after that the sprayer was hitched to the tractor, it allows to use the sprayer itself (**treatment position**).

The figure shows the adjustable support foot three possible positions

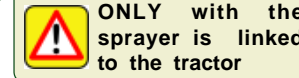
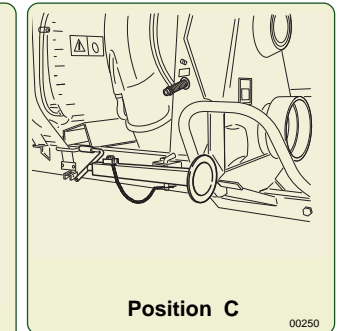
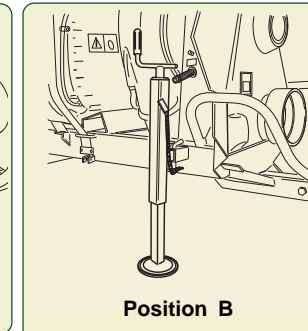
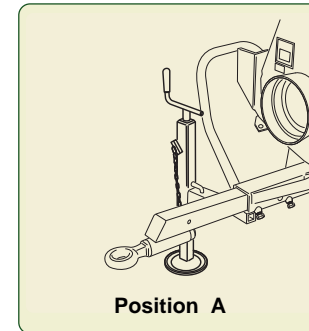

During the sprayer operation, the support foot has ALWAYS to be positioned on "C".

SUPPORT FOOT for sprayers equipped with bracket drawbar or steering drawbar for the 3-point connection, stabilizes the sprayer when it is not linked to the tractor.



ALWAYS USE the support foot to stabilize the sprayer when not linked to the tractor.

The support foot can be set at the sprayer in two different positions as needed:

Pos. A - vertically applied to the frame, it allows to regulate the length and to modify the drawbar height and stabilizes the sprayer when it is not linked to the tractor.

Pos. B - horizontally applied to the frame, after that the sprayer was hitched to the tractor, it allows to use the sprayer itself (**treatment position**).



During the sprayer operation, the support foot has **ALWAYS** to be positioned on "B".

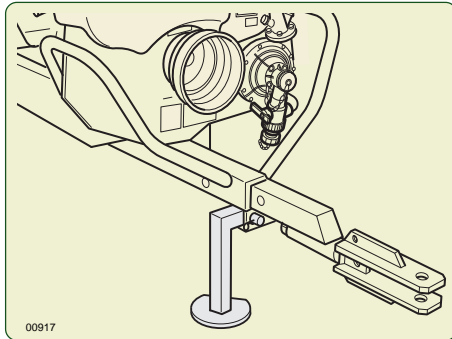

Position A

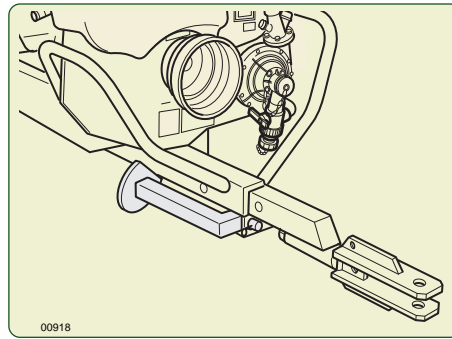

Position B

SUPPORT BRACKET mounted on the drawbar, in order to house the transmission shaft when the machine isn't hitched to the tractor.



When the transmission shaft is mounted on the 2 PTO, the bracket has always to be lowered.

THE RESPONSIBILITY FOR THE REGULATION, ASSEMBLY AND DISASSEMBLY OPERATIONS OF THE WHEELS IS CHARGED TO THE OPERATOR, WHO HAS TO PREPARE AND TO ASSURE THE NECESSARY CONDITIONS FOR A COMPLETE SAFETY AGAINST ANY POSSIBLE ACCIDENT.

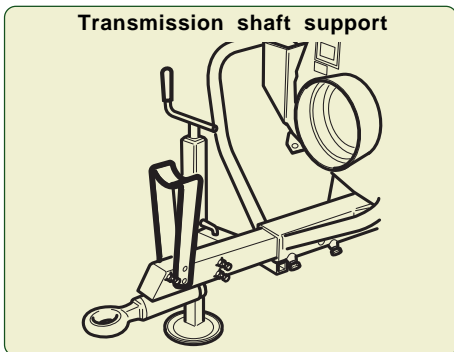

Position A

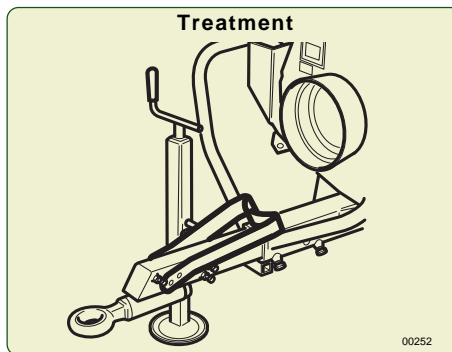

Position B

A. FAULT: By utilising the filler piping the pump doesn't operate (suction)



It is necessary to disengage the drive outlet (PTO) and wait for it to stop rotating before repeating the filling operation.

1. CAUSE: the quantity of water poured into the tank is insufficient to trigger the pump.
REMEDY: Add water to the tank until the pump starts its cycle.
2. CAUSE: the filler piping sucks in air.
REMEDY: Completely submerge the suction filter of the filler piping.
3. CAUSE: The pump filter is clogged.
REMEDY: Clean the filter
4. CAUSE: Lack of seal of the pipes.
REMEDY: Check the tightening of ring nuts, fittings and clamps. Check the efficiency of sealers and that piping elements are not cracked or broken. Replace parts that are possibly found to be defective.
5. CAUSE: Slipping of the pump's belt.
REMEDY: Check the tension of the belt-tensioner's spring. (4÷5 cm).
6. CAUSE: The pump's belt might be broken.
REMEDY: Replace the belt.

B. FAULT: Leakage and dripping from the pump

1. CAUSE: Non-sealing of the fittings and clamps connecting the piping to the pump.
REMEDY: Check for proper tightening of ring nuts and clamps. Check the efficiency of the sealers. Replace parts that are possibly found to be defective.
2. CAUSE: Mechanical sealing defective.
REMEDY: Address a C.I.M.A. point of "Sale and Service".

C. FAULT: Drop in pressure of the hydraulic circuit signalled by the gauge

1. CAUSE: Dirty filter.
REMEDY: Clean the cartridge
2. CAUSE: The pump filter is clogged.
REMEDY: Clean the filter
3. CAUSE: Faulty sealing of the hydraulic circuit.
REMEDY: Check the operation of the pump and the tension of its belt. Check the proper tightening of ring nuts, fittings and clamps. Check the efficiency of the sealers and the integrity of the piping. Replace the parts that are possibly found to be defective.
4. CAUSE: Gauge defective.
REMEDY: Replace the pressure gauge.
5. CAUSE: Suction or gauge connection pipe clogged.
REMEDY: Clean.

D. FAULT: Variations in the pressure of the hydraulic circuit (marked by the gauge)

1. CAUSE: Lack of seal of the pipes and/or the valves.
REMEDY: Check the clamping of the ring nuts, the connections and the clamps. Verify the efficiency of the gaskets and the integrity of the pipes. Replace the possibly defective parts.
2. CAUSE: Residue of product at the entrance of the gauge
REMEDY: Clean.

13.9 - TABLE OF MAINTENANCE OPERATIONS

Check	SEASON START TREATMENTS	BEFORE EVERY TREATMENT	END OF EVERY TREATMENT	SEASON-END	RECOMMENDED FREQUENCY
Fan belt-tensioner spring: CHECK LENGHT 9-12cm.	YES	YES	**	**	**
Pump belt tensioner spring: CHECK LENGHT 4-5cm.	YES	YES	**	**	**
Fan shaft support: CHECK OIL LEVEL	YES	YES	**	**	8 hours
Fan shaft support: REPLACE OIL	**	**	**	YES	1 hour
Tank: CHECK BELT CONDITION AND PROPER TIGHTENING	YES	YES	**	**	**
Fan belt-tensioner support: GREASING	**	**	**	YES	200 hours
Free Wheel: GREASING	**	**	**	YES	200 hours
Wheels bearing: GREASING	**	**	**	YES	200 hours
Support foot: GREASING	**	**	**	YES	200 hours
Filter: CHECK CLEANING	YES	YES	YES	YES	**
Fittings and piping: CHECK GOOD CONDITION	YES	YES	**	YES	**
Clamps and fittings: CHECK FOR INTEGRITY, PERFECT SEALING AND THIGTENING	YES	YES	**	**	**
Presure gauge drain plug: UNSCREW AND CLEAN	**	**	YES	YES	**
Drawbar: CHECK THE SCREWS AND FIXING BOLT TIGHTENING	YES	YES	**	YES	**
Steering drawbar(for versions in which this envisaged): GREASING	**	**	**	**	200 hours
Wheels: CHECK THE NUT TIGHTENING AND CHECK TIRE PRESSURE	YES	YES	**	YES	**
Axle and wheel hubs: CHECK THE NUT TIGHTENING AND CHECK THE BOLT TIGHTENING	YES	YES	**	YES	**
Hydraulic circuit and tank: COMPLETELY DRAIN AND WASH	**	**	YES	YES	**
Sprayer: EXTERIOR WASHING	**	**	YES	YES	**
Sprayer: STORAGE	**	**	**	YES	**

BLITZ 008

4.2 - STEERING DRAWBAR (on demand)

IT IS NECESSARY TO USE THE HOMOCYNETIC CARDAN SHAFT.

The steering drawbar has to be mounted instead of the standard drawbar.

It has to be fixed to the frame by a through screw provided with a a self-locking nut and locked by means of the two lateral screws.

4.2.1. - Drawbar for the towl hook

It has a coupling plate to the tractor rear hook. On the drawbar a support bracket is mounted for housing the cardan shaft when the sprayer is not hitched to the tractor. The frame is the same as the one of the standard drawbar. (see point (4.1)).

4.2.2. - Drawbar for the 3-point connection

It has a coupling triangle with two pins and the 3-point pin arranged for the hydraulic power-lift - "1" and "2" category, or only a coupling bar for the connection with the two lower pins.

- Category "1": 22 mm. diam.pins - 19 mm. diam. 3-point pin.
- Category "2": 28,5 mm. diam.pins - 25 mm. diam. 3-point pin.

The frame features are the same ones of the standard drawbar. (see point (4.1)).

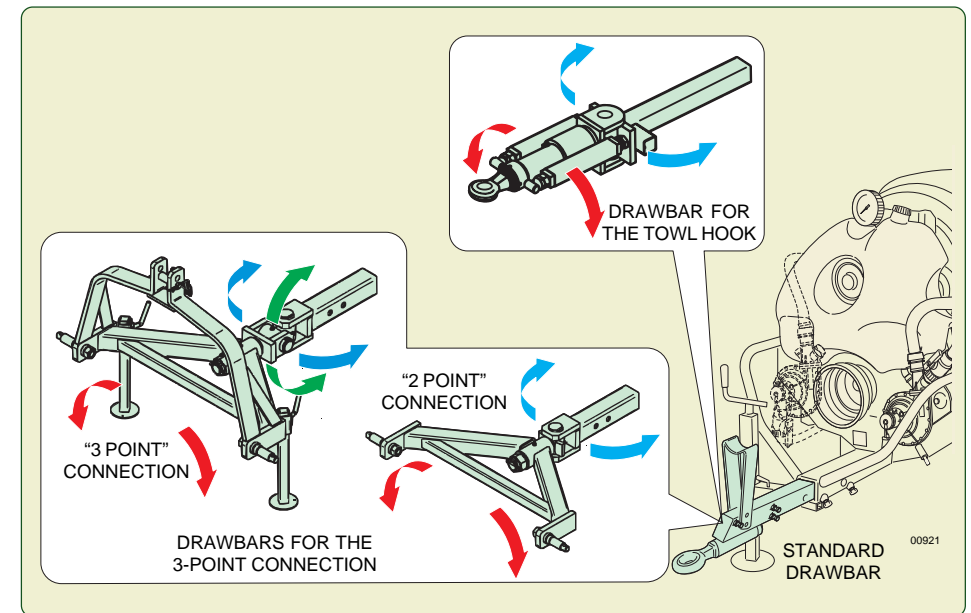

AXLE. It is fastened by means of four bolts to the frame. The axle can be mounted in three different positions, so modifying the wheel base between the wheels and the drawbar. The wheels' axle shafts, inserted in the frame axle and locked there by some especially foreseen screws, allow to regulate the **track width**, by adapting it to the intervention requirements.

— The height with respect to the ground can be regulated. (The misalignment between the axle shaft and the wheels' hub allows a variation of 12 cm). It is enough to turn the axle shafts.

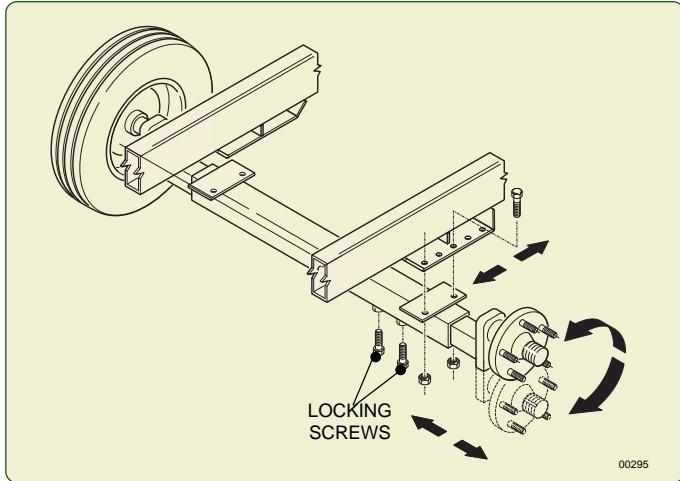

After every regulation, carefully tighten all the screws and the bolts concerned by the intervention.

WHEELS. The wheels' hubs are equipped with grease nipples for the bearings lubrication (see 14.1). The tyres' size and the operating pressure are indicated at step 4.5.2.

HEAD PROTECTION RING. It is applied behind the machine, in order to protect the distribution devices (heads). It has to be mounted in the most efficacious position, according with the working conditions and with the kind of head.

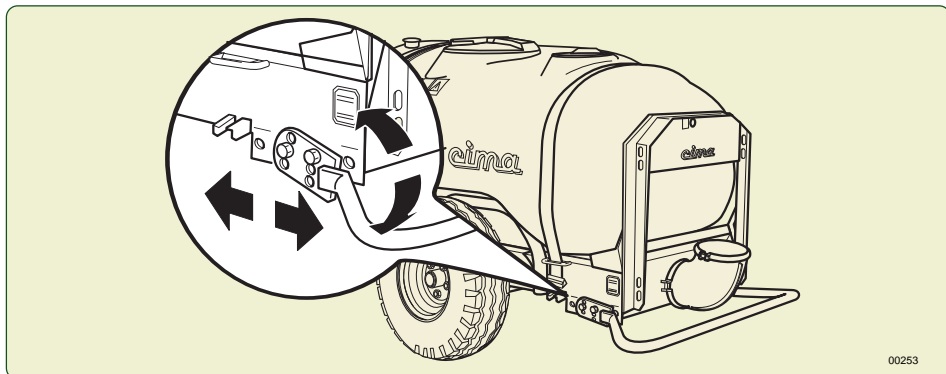

13.7 - PUMP BELT TENSIONER

Check length "L" of the spring (refer to picture): it should be in tension between **4 and 5 cm**.

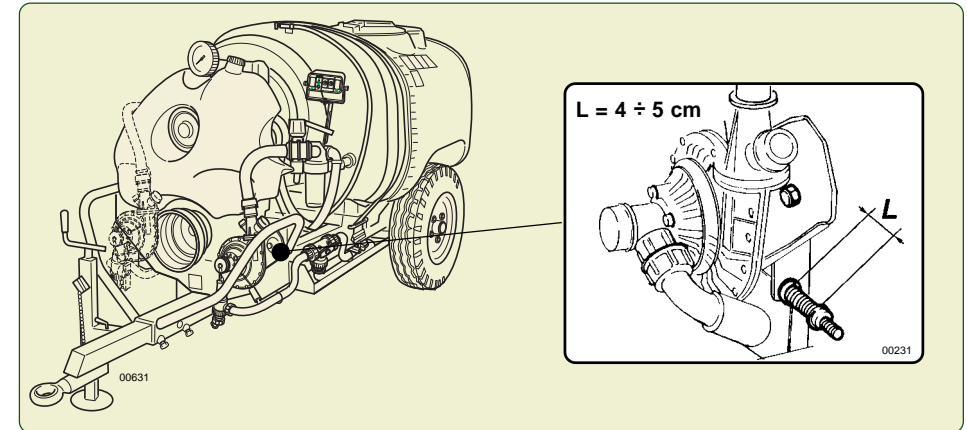

If the value measured exceeds 5 cm, tighten the belt tightener screw, up to get the minimum length (4 cm).

13.8 - MAIN TANK FASTENING BELT



The adjustment of the belts takes place during the first 3÷4 hours of use of the atomizer; after this period check and restore the correct tension of the belts so that the perfect block of the main tank to the frame will be guaranteed, this way preventing any damages or breakups of the tank itself.

Check the tension of the fixing belts of the main tank to the frame. To restore the correct tension of the belts screw in the register screw (4) on both sides of the tank.

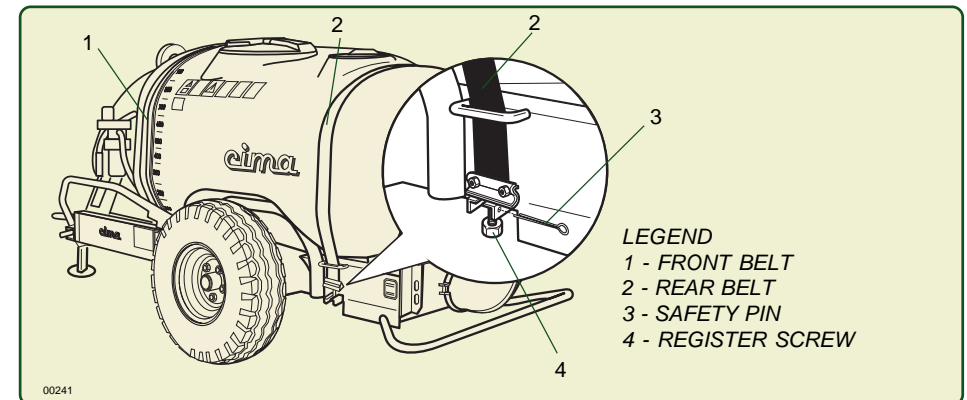

4. Remove the two collar (5) fastening bolts, fixing the fan casing to the rear cover.
5. Extract the fan casing (2).



The impeller hasn't to be disassembled.

7. Clean the impeller, by avoiding to use high pressure water jets: they can cause infiltrations into the fan shaft support and consequently damage the bearings.
8. Mount back the casing (2), by paying a particular attention to get it perfectly coupled with the rear cover.
9. Fasten the fan casing, with the collar (5), to the rear cover and with the collar (1) to the connection tunnel of the spray-head.



Carefully tighten all the fastening collars' bolts.

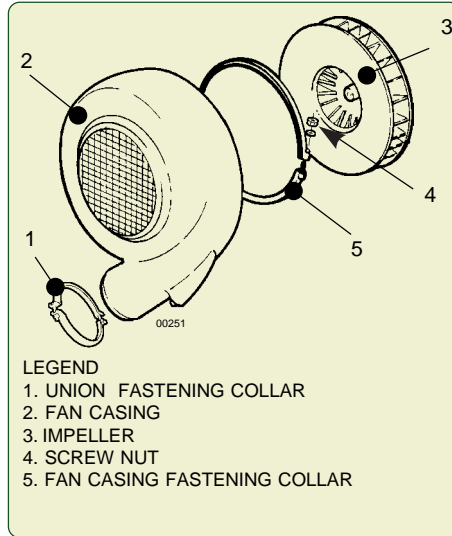

13.6 - FAN BELT TENSIONER

Check length "L" of the spring (refer to Picture): it should be in tension between **9 and 12 cm**.

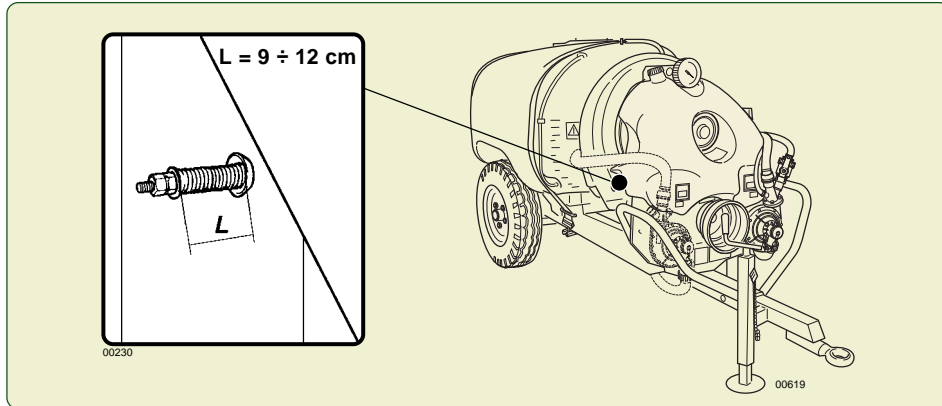

If the fan control belt has to be replaced, the correct tensioning of the same one (spring length) has to be OBLIGATORILY checked after the first and after the second operation hour.

If the value measured exceeds 12 cm, tighten the belt tightener screw, up to get the minimum length (9 cm).

The belt setting will take place within the first 2÷3 operating hours; when that time has elapsed, verify the spring length, according with the time intervals (periodicity) indicated in the "Maintenance operations' table".

4.3 - FAN SERVO AMPLIFIER

It is positioned in the unit front section and protected by a plastic casing.

Servo amplifier

It is equipped with an automatic tensioner of the driving poly-V belts that keeps the belt tension constant, avoiding slipping and wear. A **free-wheeling gear** (for the version where foreseen) is included between the Power Take-off of the servo amplifier and the fan control pulley (refer to the picture). In case of sudden decelerations or unexpected engine stoppage, this allows the fan to continue its free rotation, thus avoiding extreme mechanical stresses to be transmitted to the drive members.

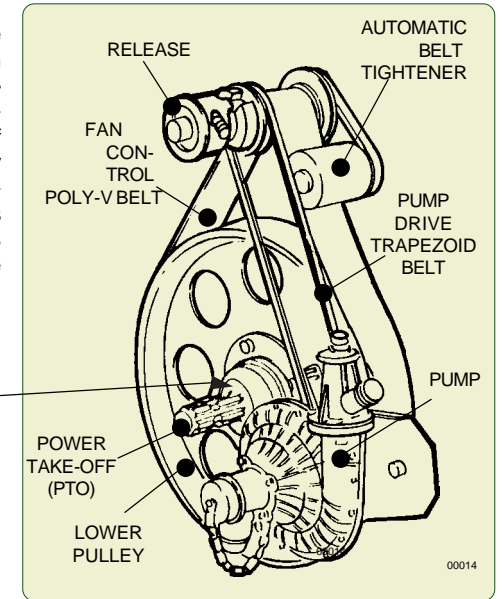
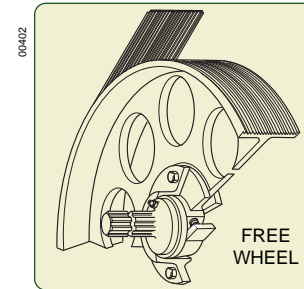

Centrifugal fan

The **front-engaging clutch** assembled on the fan shaft allows the operation of the centrifugal pump whitout the fan (for versions in which this is envisaged). An air intake predisposed on the casing external edge is connected, by means of a pipe equipped with a cock, to the tank inner agitator. Through this tap it is possible to carry out or exclude pneumatic agitation. The closed vanes-type impeller is realized in dynamically balanced sheet steel; the air intake opening on the casing is protected by a grating, especially foreseen for this purpose.

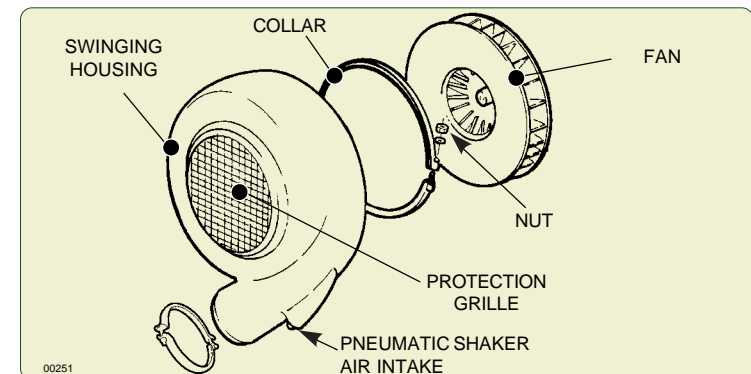

4.4 - HYDRAULIC CIRCUIT COMPONENTS

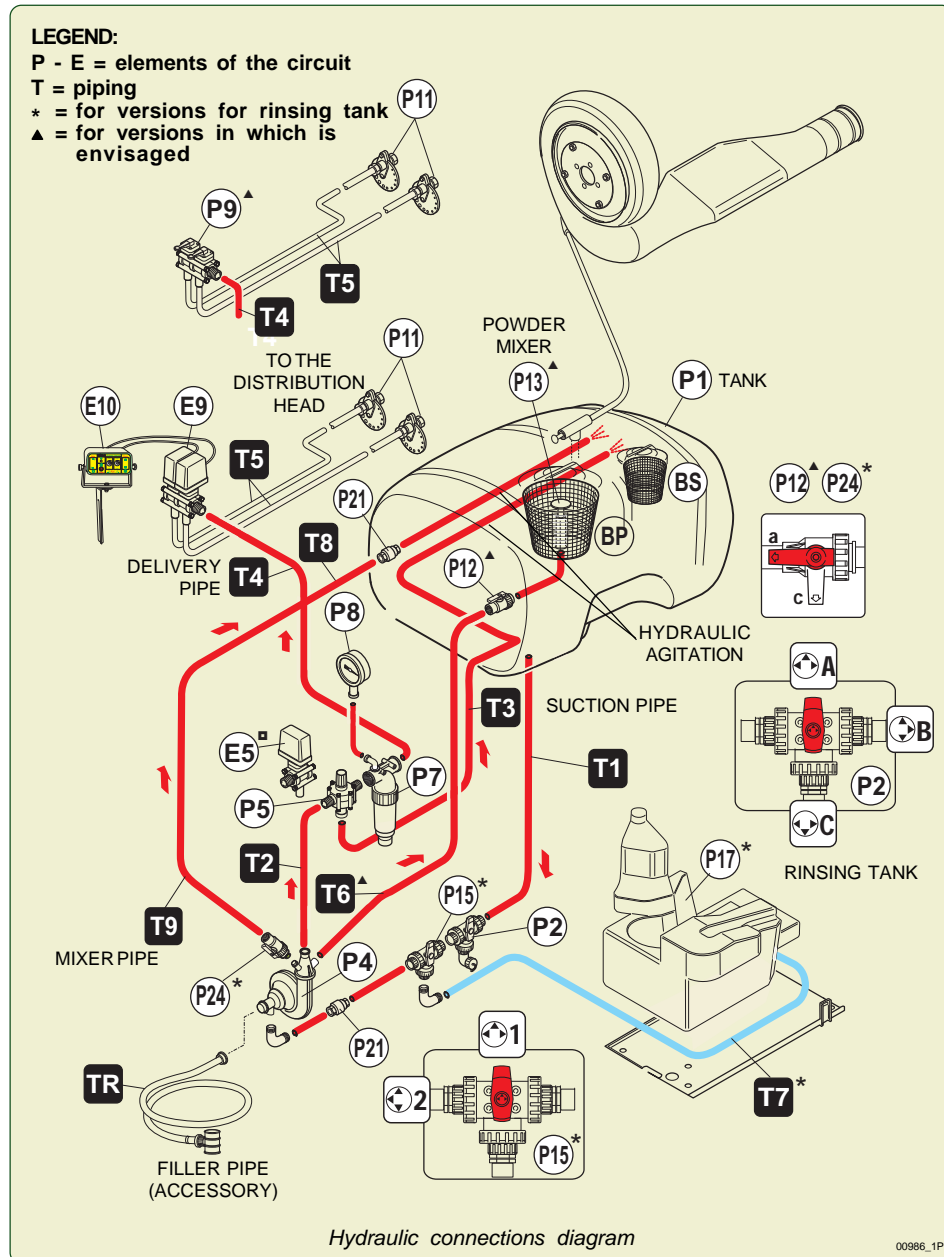

13.3 - FAN SHAFT SUPPORT OIL REPLACEMENT



Let the fan shaft support oil replacement intervention be carried out at a C.I.M.A. customers' service centre, or observe the regulations in force for the disposal of the used oil.

1. Unscrew and remove the oil filling plug with the dipstick.
2. Remove the oil drain plug and let the oil completely flow out from the fan shaft support.
3. Check the oil drain plug and the relevant seal for integrity, replace them, if necessary, and close again the oil drain plug.
4. Through the filling pipe, pour a SAE 90 oil proper quantity, up to reach the MAX notch on the dipstick:
 - about 0,19 kg for the 45 model
 - about 0,24 kg for the 50-55 model.
5. Position again the plug with the dipstick and close the oil filling pipe.

13.4 - CLEANING OF FILTER'S CARTRIDGE

1. Set the lever of 3-way tap (P2) to the "B" position.
2. Completely close the pressure regulator, by turning clockwise the handle of the manual regulator (P5) or by turning the pressure up (keep the joystick on "+" for about 15 seconds) if the atomizer is provided with electric regulator (E5).
3. Position the switches of the control electric switchboard (E10) on "OFF" or close the manual distributor's taps (P9).
4. Undo the thumb screw and remove the body of the filter.
5. Extract the cartridge: clean the grill and the retaining O.Ring.
6. Reassemble the cartridge and secure the lid with the thumb screw. **Pay attention to the O-Ring of the lower body during the assembly:** the incorrect sealing of the filter will jeopardise the proper operation of the sprayer and cause loss of the mixture.

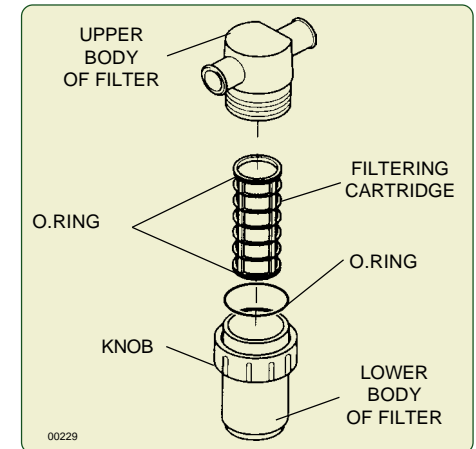

13.5 - CLEANING OF THE FAN



It is advisable for the cleaning of the fan to be carried out at a C.I.M.A service point. Dirt accumulation or incrustations can unbalance the fan, inducing vibrations that could cause breakage

1. Remove the distribution device (head).
2. Remove the fastening collar (1), fixing the fan casing outlet orifice to the connection tunnel of the spray-head.
3. Remove the two collar (5) fastening bolts, fixing the fan casing to the rear cover.

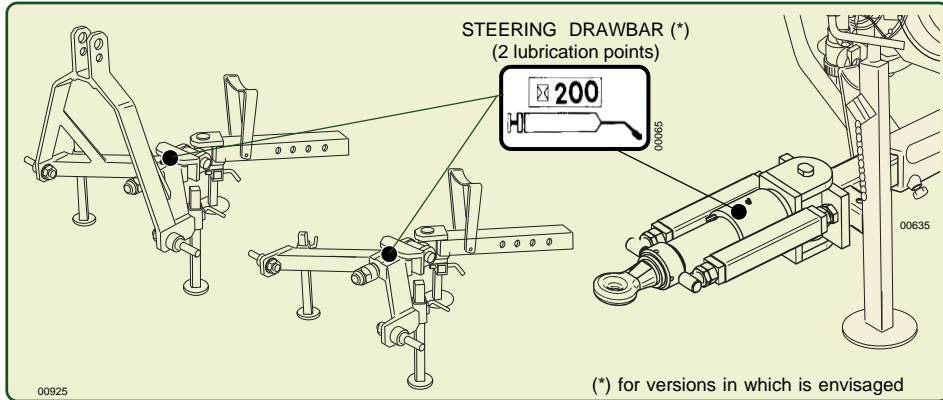

13.2 - FAN SHAFT SUPPORT OIL LEVEL CHECK

1. Unscrew and remove the oil filling plug with the dipstick.
2. Clean the dipstick and introduce it again.
3. Extract the dipstick and check the oil level, which has to be between the two minimum and maximum level notches of the dipstick itself.
Should it be necessary to top up the level, add some SAE 90 oil, up to reach the dipstick upper notch (MAX).
4. Introduce and screw the oil filling plug with the dipstick.

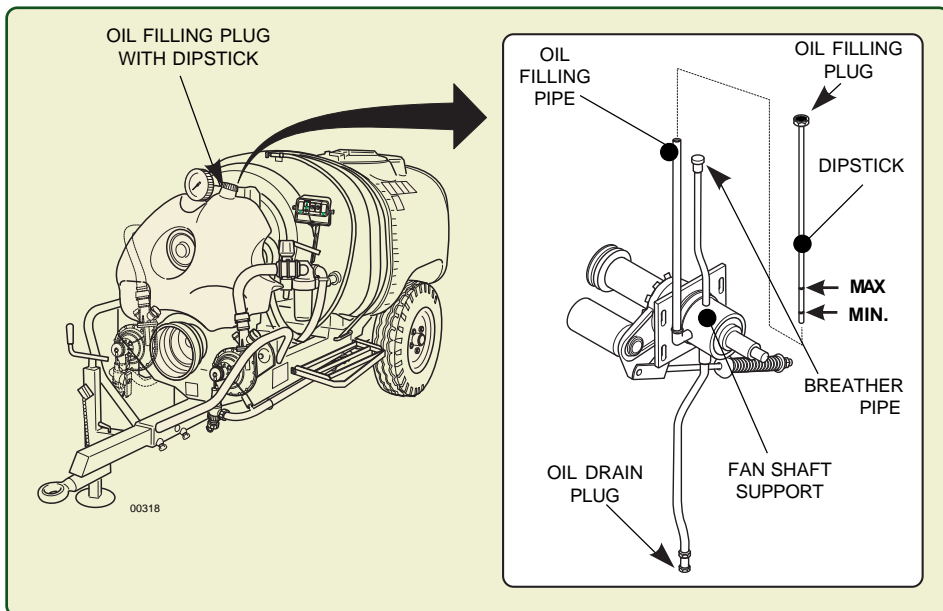

Versions with additional agitation pump

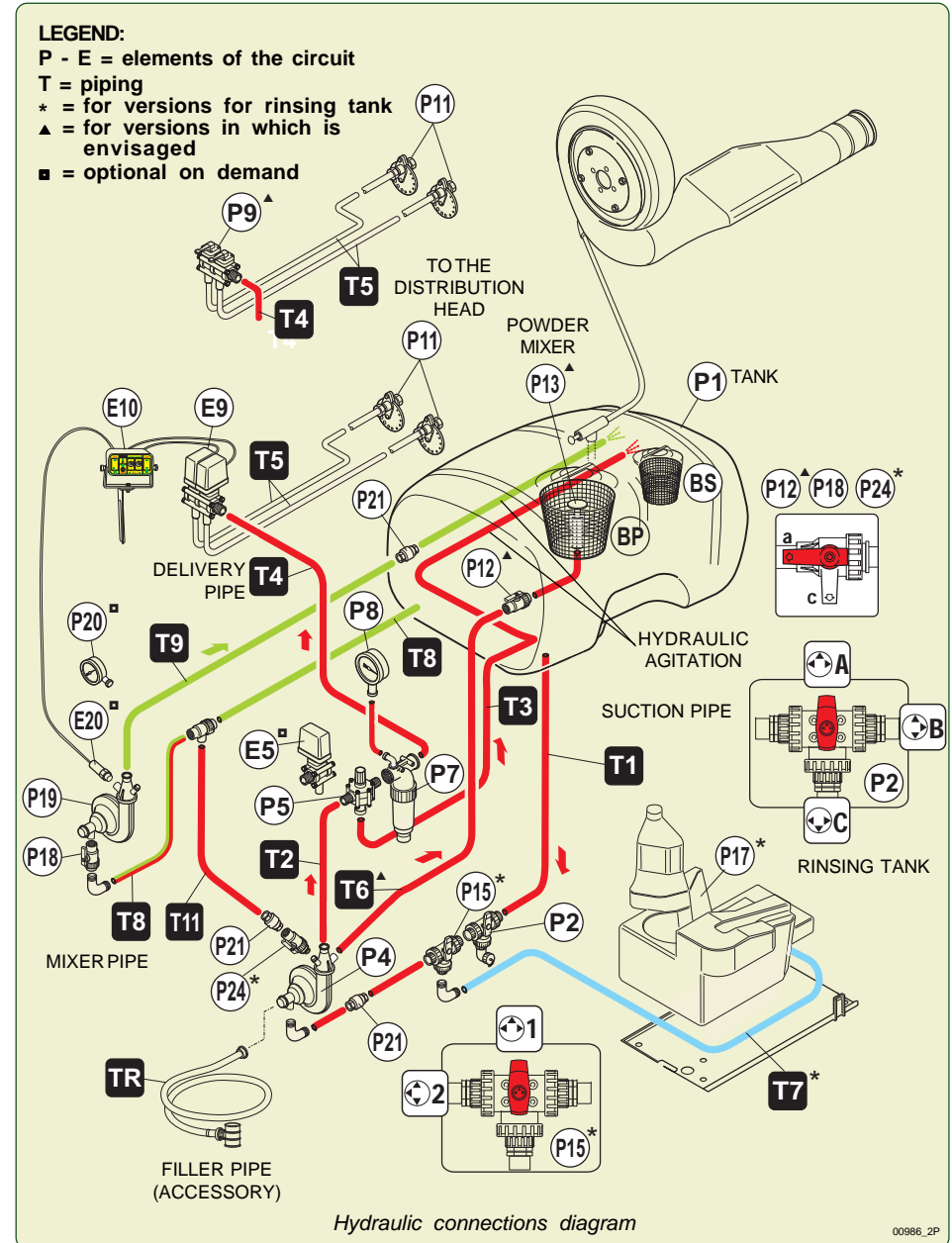

E.P.A. versions

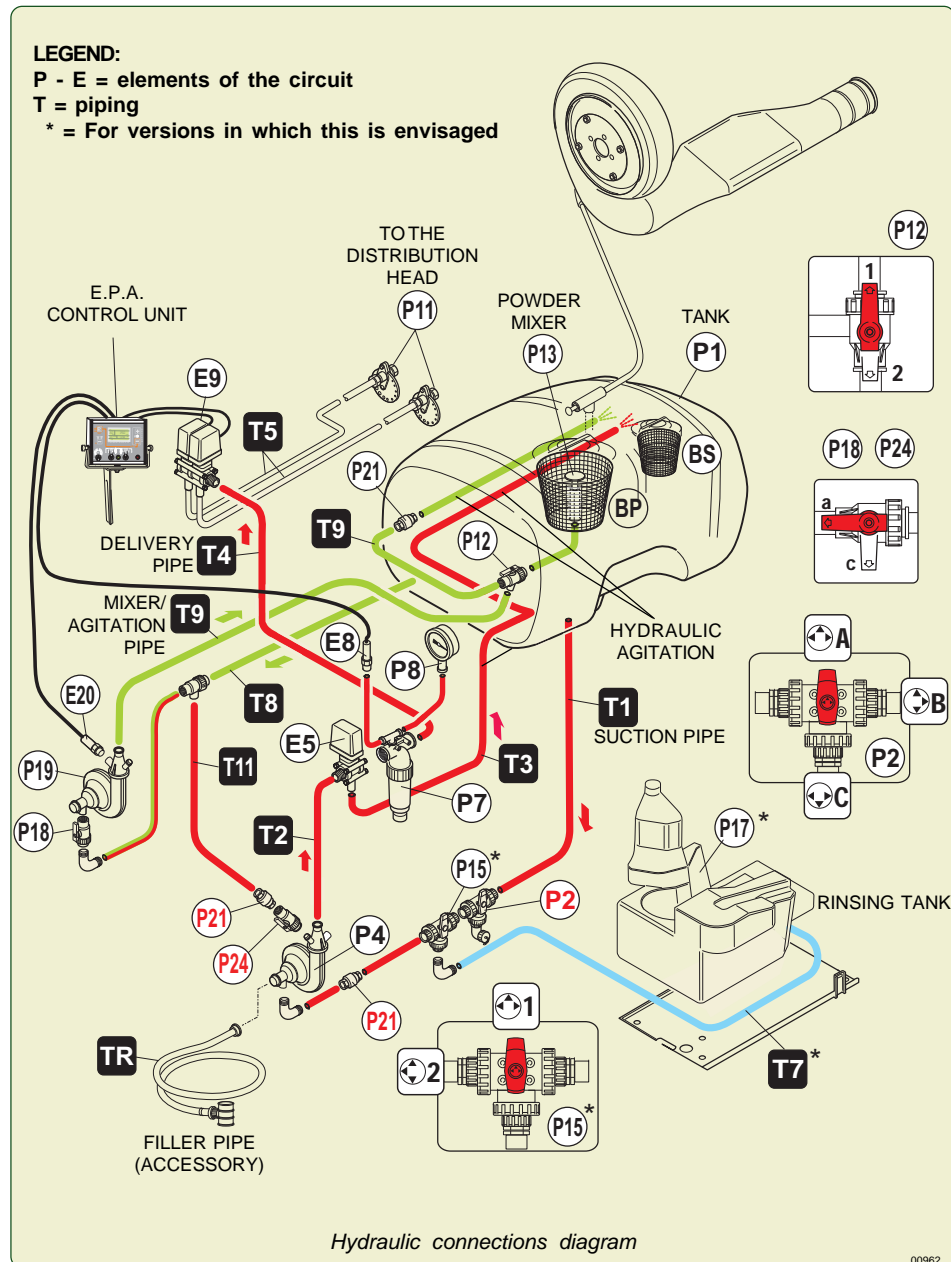

13 MAINTENANCE OPERATIONS 13



ALL OPERATIONS MUST BE CARRIED OUT WITH THE ENGINE SWITCHED OFF AND WITH THE IGNITION KEY REMOVED FROM THE CONTROL PANEL.

13.1 - LUBRICATION

Maintenance Point	Action	Consumption material	Periodicity
Fan shaft belt support	Check Oil	Oil SAE 90	8 hours
Fan belt-tensioner support	Greasing	Grease Tipo EP Class NLGI 2	200 hours
Free wheel	Greasing	Grease Tipo EP Class NLGI 2	200 hours
Wheel hubs	Greasing	Grease Tipo EP Class NLGI 2	200 hours
Support foot	Greasing	Grease Tipo EP Class NLGI 2	200 hours
Steering drawbar	Greasing	Grease Tipo EP Class NLGI 2	200 hours
Fan shaft bearings support	Change oil	Oil SAE 90	1 year

BLITZ07



Carefully clean the greasing nipples and the oil filler in order to avoid that, during lubrication, dirt might be introduced. In the case of intensive use of the machine, reduce the lubrication intervals.

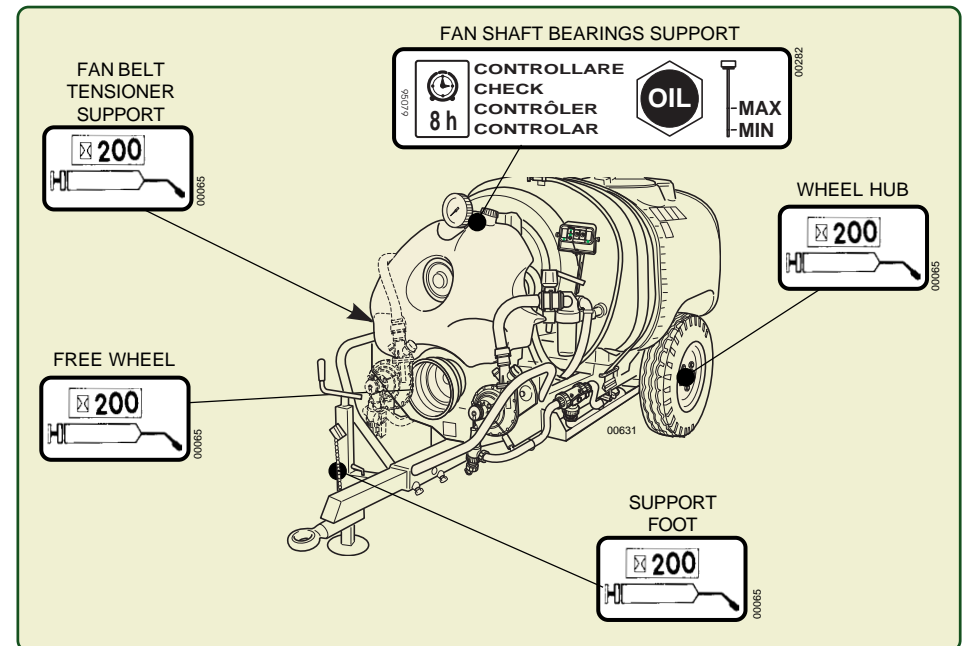



THE FOLLOWING ACTIONS ARE NOT ALLOWED:

- Transporting or lifting the sprayer with residual quantities of mixture in the tank for purposes differing from its destined usage.
- The transporting of people, animals or things.
- The trailing of vehicles or equipment.



Road transport must take place in the complete observance of road regulations in force in the Country where the machine is used. The operator is responsible for possible defaults due to the non observance of said regulations.

• **Lifting and transport of the sprayer**



Before carrying out any operation it is essential to verify that no mixture residues are left in the tank.

1. Check that the lifting devices (bands, ropes, etc.) are adequate for the weight to be lifted (machine – distribution devices - accessories).
2. Hook the machine through the specific support point indicated by the specific decal on the frame, checking all the parts involved in the operation.
3. Lift the machine, verifying that it is properly balanced.

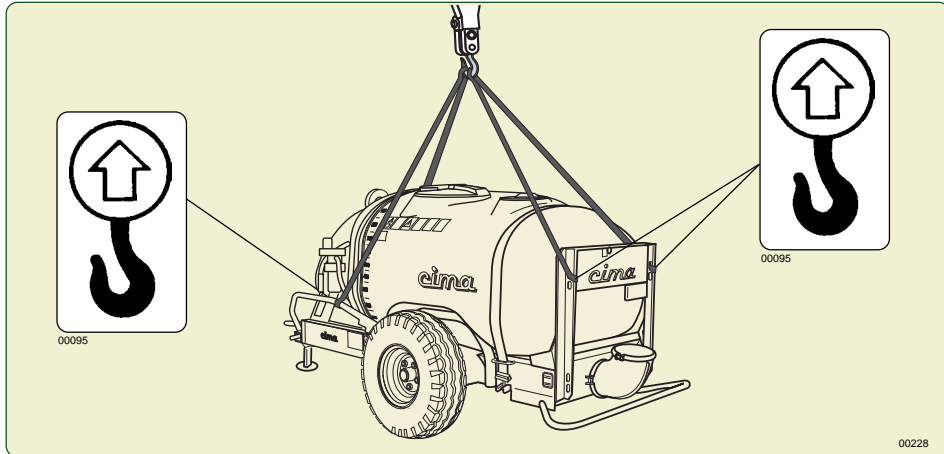

4. Position the sprayer on the transporting vehicle in perfectly stable conditions.
5. Lock the sprayer with the wedges locking wheel.
6. During transport the machine must be immobilised and fastened to the carrier by way of suitable strapping.

P1. MAIN TANK

Polyethylene tanks of 600, 800, 1000, 1500 and 2000 litre capacity

Each tank is made up of:

- tank main filler, (BP) with a 355 mm. diam.hinged cover (on 600 ltr. tank) or with a 400 mm diam.hinged cover (on 800, 1000, 1500 and 2000 ltr.tank), with breather pipe; Plastic cup-like filter: 302 mm external diameter, height 254 mm, powder mixing device (for versions in which this envisaged);
- supplementary tank filler with 250 mm diameter screw-type lid, for filling with clear water and plastic cup-like filter: external diameter 204 mm, height 240 mm;
- transparent level indicator external pipe with graduated scale, (One on the left-hand side of the tank L1 and one on the front side L2);
- hydraulic agitation connected to the return piping (T3);
- pneumatic agitation;
- piston cock, positioned over the tank and connected through a pipe to the air inlet, which is placed on the fan casing, for opening/closing the pneumatic agitation (only for sprayers with 600, 800 and 1000 litres tanks);
- ball cock, placed on the pipe connecting the air intake, which is positioned on the fan casing, with the coupling in the tank upper section, for opening/closing the pneumatic agitation (only for sprayers with 1500 and 2000 litres tanks).

P22. ADDITIONAL HAND-WASHING TANK

30-litre polyethylene tank, with external tap.

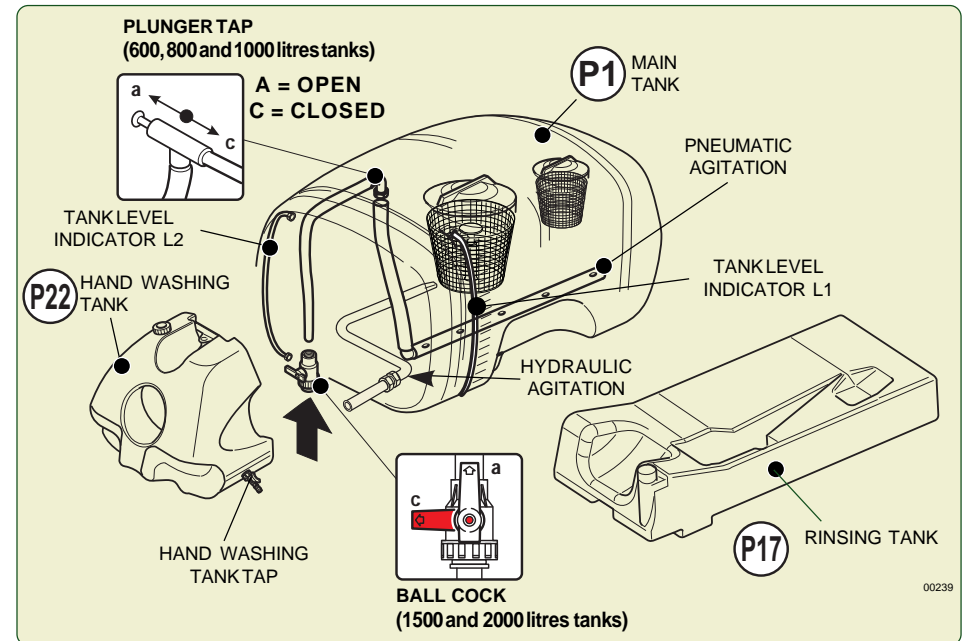

P2. 3-WAY LEVER TAP A WITH DISCHARGE FITTING

Positioned on the pipe (T1), between the tank (P1) and the pump (P4), it is equipped with a closing plug of the discharge fitting, with the relevant safety chain.

The 3-way lever (P2) can be positioned as here following specified:

A - Treatment

The liquid gets out from the tank (P1) and is sucked by the pump (P4); this is the **NORMAL** operating position, which is used in order to carry out the treatment and/or to keep the mixing on. The discharge fitting is closed.

B - Filling

This position is used in order to fill the tank through the especially foreseen pipe, to be applied to the fitting on the pump (P4). It is closed the suction pump from the tank, the drain plug must be properly tightened and should NOT be removed. When the cock is on that position, it is moreover possible to remove the pump (P4), also when the tank is loaded.

C - Drainage

In this position, it is possible to empty: the tank (P1), the pump (P4) and all the pipes of the hydraulic circuit.

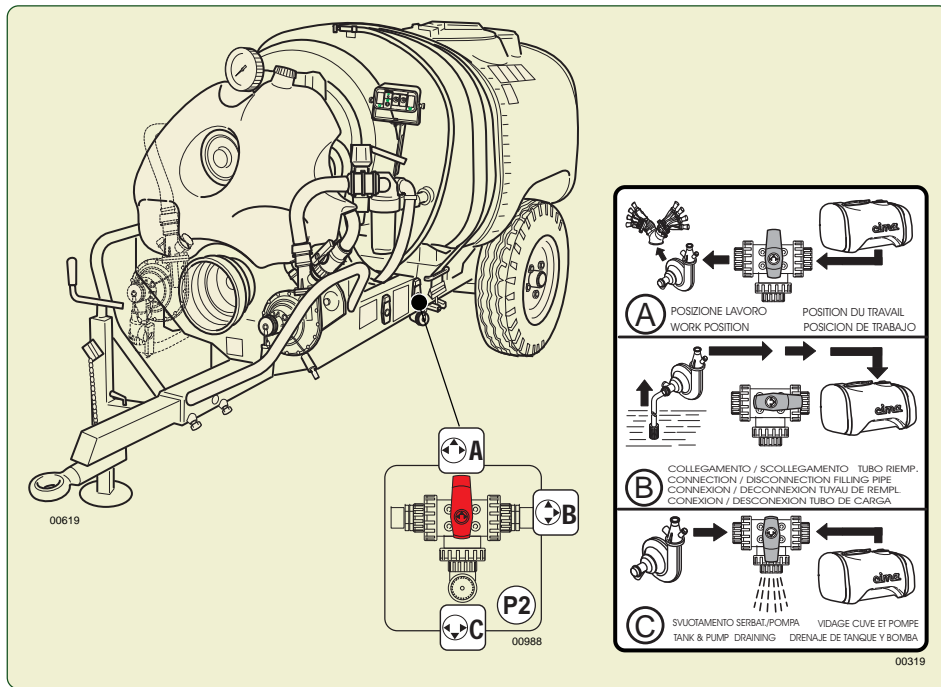

11 TANK AND HYDRAULIC CIRCUIT DRAINING 11



- Stop the tractor and remove the key from the control panel.
- Wear suitable protective clothing and accessories in order to avoid contamination by contact or inhalation of the mixture.
- Carry out the discharging in a suitable and properly geared area for the collection of the washing liquid.

This operation has to be carried out with the 3-way cock (P2):

1. Position the lever of the 3-way cock (P2) to “A - WORK POSITION” (draining closed).
2. Unscrew the drainage plug.
3. Turn the lever to position “C - DRAINING” (draining open).
4. When the draining is completed, position again the lever of the 3-way cock (P2) to “A” (draining closed), and screw again the chain plug.

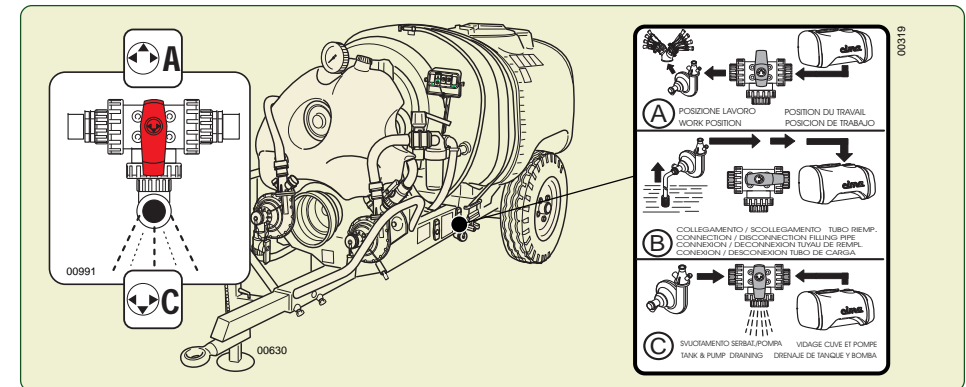

For the version where foreseen:

1. To make the discharge of the circuit of additional agitation pump (P19) close the cock (P18), position "2".
2. Unscrew and remove the drain plug with chain from pump (P19) to drain the pipes.
3. Complete emptying, replace drain plug and return the lever cock (P18) to "1".

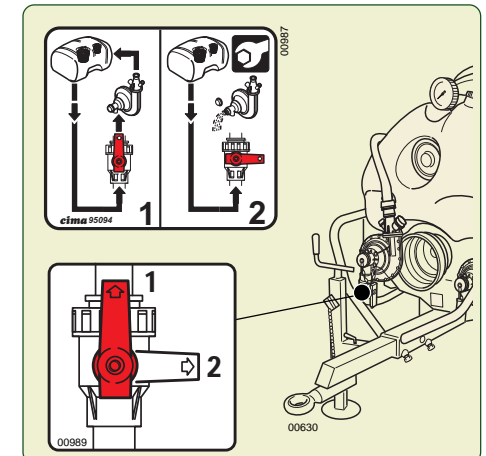

10.5.2 - End of seasonal cycle

- **The operator must:**

- Take the utmost care in carrying out the operations envisaged at the end of the daily treatments: the cleaning of the hydraulic circuit must be done at least twice. Check that no product residues are left in any part of the circuit.
- Execute the necessary maintenance and lubrication operations (see paragraph 15.9), then let the atomizer operate for some minutes.



THE PUMP HAS NEVER RUN DRY

- Completely drain the hydraulic circuit, paying a special attention to the centrifugal pump; in order to completely drain the pump, remove the draining plug, which is mounted on the pump itself.

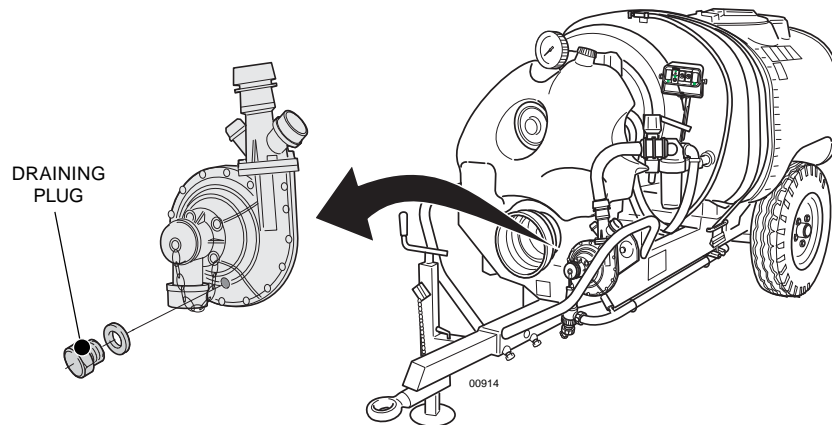

Avoid using anti-freeze solutions.

- Check the proper operation of all parts and of the machine structure. In case of faults being detected, request the intervention of one of our service points.
- Keep the machine in a well ventilated place, sheltered from rain, icing and direct sun rays.



The use of detergent products for the cleaning operations is allowed only in the observance of the regulations in force. For these, the operator must gather the relevant information from the specifically appointed bodies ruling on this subject.

P4. CENTRIFUGAL PUMP

Fastened on the unit left front section, it is connected with the 3-way cock (P2) and with the pressure regulator (P5). The pump is provided by the suction side of a filter to prevent the accidental entry of foreign bodies in the pump body, such a possibility does not constitute a hazard and can only cause damage to the impeller shown by a drop in pressure reported by gauge

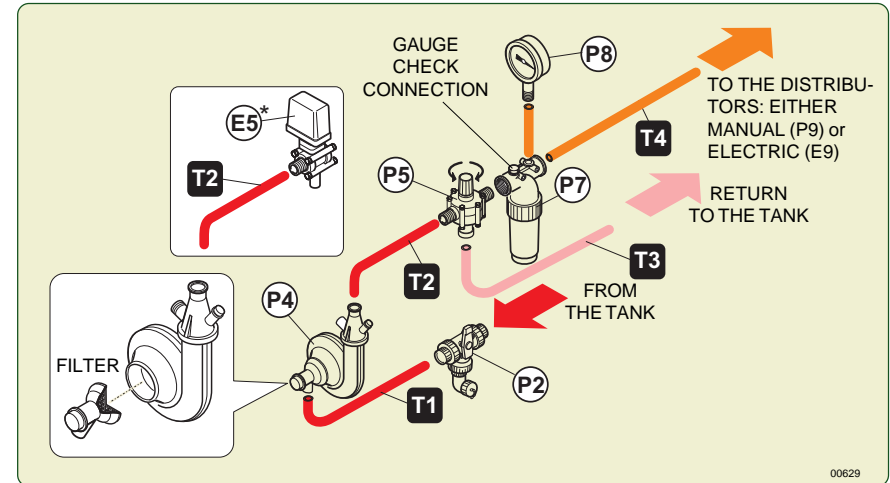

THE PUMP MUST NEVER RUN DRY

The water must be always in the pump : ALWAYS check this point carefully at the start up and during the functioning.

To avoid any damage to the pump :

- At the first filling and at every next filling after the hydraulic circuit draining, fill the tank with an appropriate quantity of water to fill the pump completely;
- In order to control that the pump is not running dry, AFTER engaging the PTO, check that the pressure gauge (P8) shows an operating pressure value above 0 (zero).

P5. MANUAL PRESSURE REGULATOR

It is connected to the delivery filter (P7) and, through pipe (T3), to the tank (P1). It regulates the operating pressure, by controlling the return flow to the tank.

- **By closing it:** it REDUCES the return flow to the tank and therefore, the agitation of the mixture, and increases the operating pressure and the capacity flow to the head (rotate the handle clockwise).
- **By opening it:** it INCREASES the return flow to the tank and therefore, the agitation of the mixture, while reducing the operating pressure and capacity flow to the head (rotate the handle anti-clockwise).

E5. PRESSURE CONTROL ELECTRO-VALVE (for the version where foreseen)

It is connected to the delivery filter (P6) and to the tank (P1), through the pipe (T3). It adjusts the operating pressure checking the backflow into the tank.

- Moving the joystick downwards (-) on the electrical control gearbox, the electrovalve opens: in the tank both the backflow and the agitation of the mixture increase while the values of the working pressure and the delivery to the sprayhead decrease..

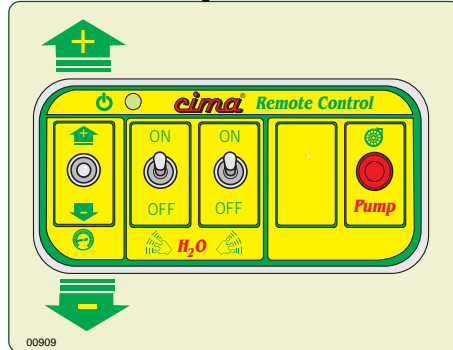

- Moving the joystick upwards (+) on the electrical control gearbox, the electrovalve closes: in the tank both the backflow and the agitation decrease while the values of the working pressure and the delivery to the sprayhead increase.

In the E.P.A. versions, the pressure regulation is **automatically** controlled by the electronic control unit (see specific manual).

P7. FILTER

It is connected to pressure regulator (P5) and, through pipe (T4), to the distributor (E9/P9). The filter has a filtering capacity of 250 l/min., with a 50 mesh cartridge. The dirty cartridge causes the operating pressure chute. This inconvenient is signalled by the pressure gauge. Mounted on the feeding pipe, it only filters the delivery flow to the heads, by sensibly reducing the possibility for the cartridge to get obstructed. On the body of the filter there is an attack, with internal thread 1/4", to make a functional test of the gauge (P8).

P8. GAUGE

Glycerine-dipped, with dial from 0 to 6 Kg/cm² (atmosphere) – adjustments scale of 1/10 of atmosphere, 100 mm diameter; it is connected to filter (P7).



Set the working pressure keeping the E9 (or P9) distributors opened.



E8. TRANSDUCER OF THE DELIVERY PRESSURE

(for the version where foreseen)

In the E.P.A. versions, the pressure transducer is connected to the delivery control computer. (see the specific manual).

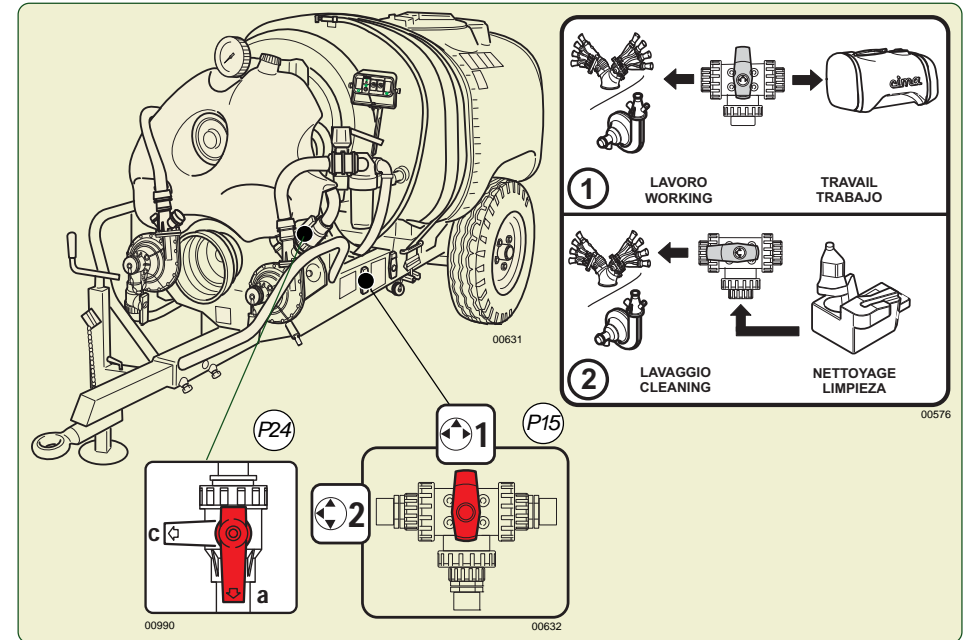

10.5 - END OF TREATMENT - STORAGE

10.5.1 - Daily

- **The operator must:**

- Wash the machine's exterior before cleaning out the hydraulic circuit. The operative sequence will permit the elimination of possible water residues from the fan casing and piping conveying the air flow to the heads.



The washing of the sprayer's exterior must be carried out in an area in which foul waters are collected in a disposal pit. DO NOT UTILISE HIGH-PRESSURE HYDRO-CLEANERS.

- Carry out the complete hydraulic circuit cleaning process, by washing the tank inside with a clean water jet; then, he has to operate the sprayer, by spraying the tank contents on the ground, in conformity with the antipollution directives in force in the country where the machine is employed: if necessary, repeat the whole procedure.
- Check the efficiency of the distribution device (head) and the cleaning of the pulverising points (diffusers), possibly replacing them if found to be damaged.
- Clean out the filter cartridge.
- Keep the machine in a ventilated place, sheltered from rain or sun: sunrays are the worst enemies of plastic and rubber parts.

- g. Keep to the preliminary operations already indicated (10.1.c), in case of wind conditions prevailing.
- h. During the breaks, stop the engine, remove the key from the tractor's control panel.
- i. Pay particular attention to the treatment when close to boundaries and in proximity of dwellings, waterways, roads or public-usage paths.

10.4 - PROCEDURE TO WASH THE HYDRAULIC CIRCUIT (head-pump)



In case of machines equipped with unit-washing tank, every time it is necessary to suspend the treatment, it is possible to carry out the hydraulic circuit washing process, independently on the loading conditions, i.e., also when the tank is still containing some product mixture, so avoiding any possible clogging and assuring the perfect efficiency of the machine when the treatment is carried on again.

In case of prolonged idle periods, it is recommended to keep the mixture agitated (see Chapter 9).

In order to carry out the hydraulic circuit washing process, follow the instructions here specified:

- a. Close the pressure regulator completely, by rotating the hand regulator (P5) handle clockwise or by turning the pressure up (keep the joystick on "+" for about 15 seconds) if the atomizer is provided with electric regulator (E5).
- b. Close the valve (P24), so the water of the spray-line rinsing circuit can not back into the main tank by varying the concentration of the mixture used.
- c. Open the cock (P15), by setting it to position "2"; in that way the clean water contained inside the unit-washing tank is sucked by the pump (P4) and gets into the hydraulic circuit.
- d. Engage the PTO and take it to the correct distribution condition (540 rev/min - see paragraph 4.4.2)



CAUTION: THE PUMP MUST NEVER RUN DRY

- e. Open the electrovalves (E9) by taking the switches of the control electric switchboard (E10) (or the manual distributor switches P9) on ON; make the atomizer work spraying on the piece of ground not treated yet.

That easy procedure allows to eliminate every fuel mixture residual from all the hydraulic circuit components, so assuring in first place the accurate cleaning and the consequent efficiency of the calibrated holes of the rotary disc regulators.

- f. Disengage the PTO.
- g. Close the cock (P15) by taking it to the **1-WORK** position
- h. Reopen the cock (P24) to restore the secondary delivery of the pump.

E10. CONTROL UNIT

It is electrically connected to the distributor with 2 motorised solenoid valves (E9) and to the main socket of the tractor (Lighter tap).

The 2 lever switches, controlling the solenoid valves (E9), have to be set to "ON" for opening and to "OFF" for closing. The control unit is equipped with a bayonet support to be inserted in the bracket provided. This must be mounted on the tractor, within the driver's reach. When the machine isn't hitched to the tractor, it must be placed in the position foreseen on the forward part of the machine frame.

In the versions with the additional agitation pump, the gearbox is equipped with a RED warning light indicating an insufficient pressure: in the versions with the pressure control electrovalve, the gearbox is equipped with a joystick for moving the electrovalve and for adjusting the delivery pressure control.

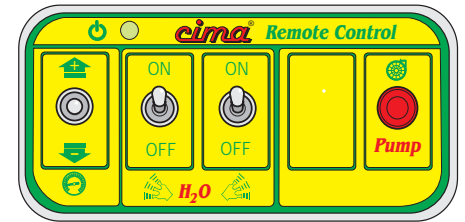

00907

E9. ELECTRICAL DISTRIBUTOR WITH TWO SOLENOID VALVES

It is connected with the feeding pipe (T4), the distribution pipes (T5) and the electrical unit (E10), which is fastened on the tractor. The solenoid valves open and close themselves, according with the action carried out on the electrical control unit switches.

In the E.P.A. versions, the controls of the cross section solenoid valves are situated on the electronic control unit (see specific manual).

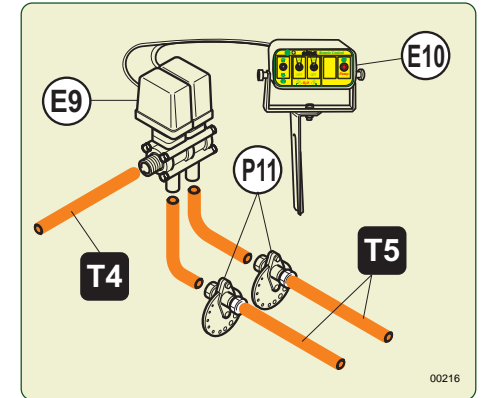

00216

P9. MANUAL DISTRIBUTOR WITH 2 LEVER-OPERATED TAPS

(for versions in which this envisaged)

It connects the feeding pipe (T4) to the distribution piping (T5). It remote-controls the closing and opening of the pulverising. The mount bracket, supplied with the machine, must be secured to the tractor within the driver's reach. When the machine is not hitched to the tractor, it must be placed on the forward part of the sprayer's frame.

Each tap permits the spraying from a single side of the head: to the right and to the left respectively. They are **open** when the levers are set in the **vertical** position.

They are **closed** when the levers are **horizontal**.

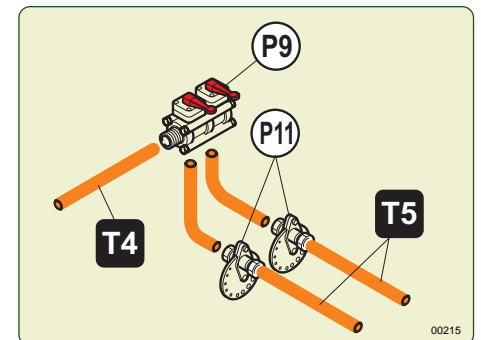

00215

P11. CALIBRATION DISC (Patent N° 23238)

It selects the flow rates necessary to the treatment and is mounted on the distribution devices. It is made up of 2 flanges, held in position by two butterfly nuts, locking a disc with calibrated holes numbered from 1 to 15. A groove on the edge of the disc allows the exact positioning of the hole to be utilised. Its number must appear in the flange's semi-circular seat. The rotation of the disc is obtained by loosening the butterfly nuts by a few turns. After the operation is done, screw back carefully.



Any faulty sealing condition of the hydraulic circuit causes an intermittent issuing of the sprayed material. It is necessary to carefully check the efficiency of the sealers and clamps, the tightening of the ring nuts and fittings and the good working condition of the piping.

LEGEND

- 1 - UNION FLANGES
- 2 - LOCKING NUT
- 3 - ROTATING DISC WITH CALIBRATED HOLES

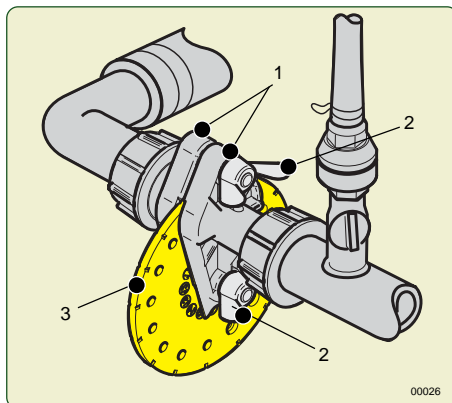

P19. ADDITIONAL AGITATION PUMP

(For versions in which this envisaged)

Fastened on the machine right front side, it is connected to the tank (P1) through the pipes (T8 - suction) and (T11 - delivery).



THE PUMP MUST NEVER RUN DRY : ALWAYS check this point carefully at the start up and during the functioning.

To avoid any damage to the pump:

- At the first filling and at every next filling after the hydraulic circuit draining, fill the tank with an appropriate quantity of water to fill the pump completely.
- In order to control that the pump is not running dry, **AFTER** engaging the PTO, on the electrical control gearbox (E10) check that the red warning light indicating an insufficient pressure is switched off or, for the versions where foreseen, that the pressure gauge (P20) shows a pressure value above 0,50 bar.

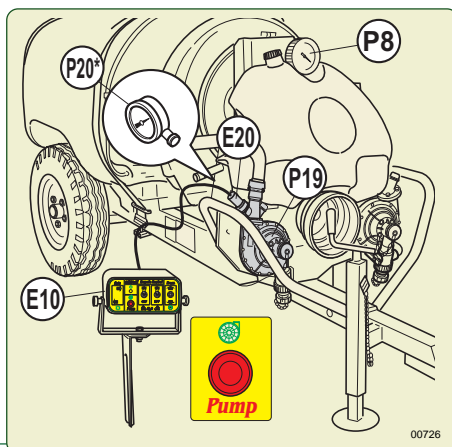

- g. Wash and rinse the just emptied product containers with clean water – collect the washing water and pour it in the tank before carrying out the filling – place the empty packaging in the specific container or in the collection area.
- h. Wash the equipment and tools utilised in the preparation and place them in the chemical products storage area.
- i. **Always** leave the area assigned to the loading and preparation of the mixtures in such condition as to avoid **any** possibility of contamination to persons or animals or of pollution to the environment.
- l. If necessary, mark the field or the area of machine passes in order to provide a guide for the treatment and avoid missing or double-treating coverage areas.



- **AT THE END OF THE OPERATIONS NECESSARY FOR CARRYING OUT THE INTERVENTION, THE LOCATION-STORAGE AREAS MUST BE LEFT IN THE CONDITION REQUIRED FOR THE CARRYING OUT OF THEIR PREVENTION AND PROTECTION FUNCTIONS.**
- **BEFORE STARTING THE TRACTOR, KEEP AWAY PERSONS OR ANIMALS AND NEVER LEAVE IT UNATTENDED DURING THE PREPARATION OPERATION.**

10.3 - THE TREATMENT



IT IS ADVISABLE TO BEGIN TREATMENT AT THE HEADLANDS



When the treatment is over, or if the same has to be temporarily interrupted, always let the fan still operate for approximately 10 sec after cutting-out the power supply (either manual distributor P9 or electrical distributor E9), in order to fully eliminate the product mixture from the distributing devices, so preventing any possible anomalous dripping from taking place.

• The operator must:

- a. **Shake the mixture** in the tank before starting the treatment, re-circulating it completely for as long as it takes to make it homogeneous.
- b. Check the **orientation of the distributors (hands, guns and/or fishtails) of the distribution device (sprayhead) in relation to the dimensions, the shape and the thickness of the vegetation to be treated.**
- c. Continue to shake the mixture until the treatment is resumed should the intervention momentarily be interrupted. If the utilisation is to be deferred, check that the filter cartridge is clean before resuming and **agitate the mixture** that has remained in the tank.
- d. Ensure that the hand wash supplementary tank is filled with clean water after each filling operation.
- e. Make use of individual protections identical to those envisaged for the preparation of mixtures if the tractor is not equipped with a pressurised cabin with aeration filters.
- f. Wash immediately all the elements that might have become contaminated during the treatment, promptly remove the polluted garments and **interrupt the work if these cannot be immediately replaced.**

- e. Carefully calculate the exact quantity of the product necessary for the treatment and establish the volume of water to be used for the intervention.
- f. Check that the product is available in a quantity sufficient to complete the intervention.
- g. Read the product's utilisation instructions carefully, in order to ascertain the usage conditions, the correct dosage and the expiration dates.
- h. Make sure of the parameters necessary to the adjustments of the machine and determine the exact dose of product to be applied to every loading. **Follow the instructions of the publication titled "The low volume - Instructions for sprayers adjustment" as well as those contained in the use and maintenance book-let of the distribution device.**

10.2 - PREPARATORY OPERATIONS TO TREATMENT



THE FILLING MUST BE CARRIED OUT WITH THE MACHINE ON A FLAT SURFACE. BEFORE THE OPERATION, IN THE ALLOCATED AREA, THE DOSES OR MIXTURES TO BE POURED IN THE TANK MUST BE MADE READY.

Before starting the filling cycle, check:

- THE TIGHTENING OF THE RUDDER, AXLE, HUBS AND WHEELS FIXING BOLTS SCREWS;
- TENSION OF MAIN TANK FIXING BELTS;
- ROAD WHEEL PRESSURE;
- THE LEVEL OF THE OIL OF THE FAN SHAFT SUPPORT;
- THE CLEANING OF THE FILTER CARTRIDGE (P7);
- THE EFFICIENCY OF THE DISTRIBUTION DEVICE (HEAD);

• **The operator must:**

- a. Wear adequate protective clothing and accessories such as overalls, waterproof suits, gloves, glasses and masks to shield him from contamination by inhalation or contact with the products handled.



- Anti-dust masks don't offer any protection against toxic vapours.
- Avoid wearing loose clothes that might entangle with moving parts.

- b. With the parameters defined during the preliminary operations, carry out the adjustments of the sprayer.
- c. Prepare the mixtures in a well ventilated area. When in the open, the presence of wind increases the danger of contamination.
- d. Precisely weigh the previously calculated doses of products to be mixed at every filling operation.
- e. Avoid handling products close to open flames, embers, incandescent bodies or in the presence of flammable substances.
- f. In order to obtain the correct volume dosage of agro-chemicals and fertiliser mixtures, the fertiliser must be first diluted.

E20. PRESSURE SENSOR OF THE ADDITIONAL AGITATION PUMP

The sensor of the pressure pump, placed on the delivery cone of the additional pump sends the pump pressure control signal to the control gearbox.



CAUTION: at starting the RED low pressure warning light is "ON" (CHECK LAMP function) and it switches "OFF" while engaging the PTO. In case this warning light is still "ON" during the working operation or at the PTO engagement, STOP the PTO and check the liquid level in the main tank. In the E.P.A. versions, the warning lamp is situated on the electronic control unit (see specific manual).



The pump pressure sensor is protected by a waterproof rubber cap. In case of malfunctioning due to a breaking or a damage occurred to the rubber cap, replace it immediately.

P18. ADDITIONAL PUMP 3-WAY LEVER TAP

(For versions in which is envisaged)

Positioned on the pipe (T7), between the centrifugal pump (P19) and the main tank (P1), it is equipped with a closing plug of the discharge fitting, with the relevant safety chain.

The control lever (P18) can be set to the following positions:

1 - Agitation

Le liquid gets out from the tank (P1) and is sucked by the pump (P19), then, through the delivery pipe (T7) it returns to the tank, so provoking a further hydraulic agitation of the mixture. **The drainage is closed.**

1 - Agitation/mixing (E.P.A. versions only)

The liquid gets out from tank (P1) and is sucked by pump (P19), and, through the agitation/mixing pipe (T8), gets back to the tank through cock (P12), which allows either the product mixing (pos. "1") or the hydraulic agitation of the mixture (pos. "2"). **Outlet is closed.**

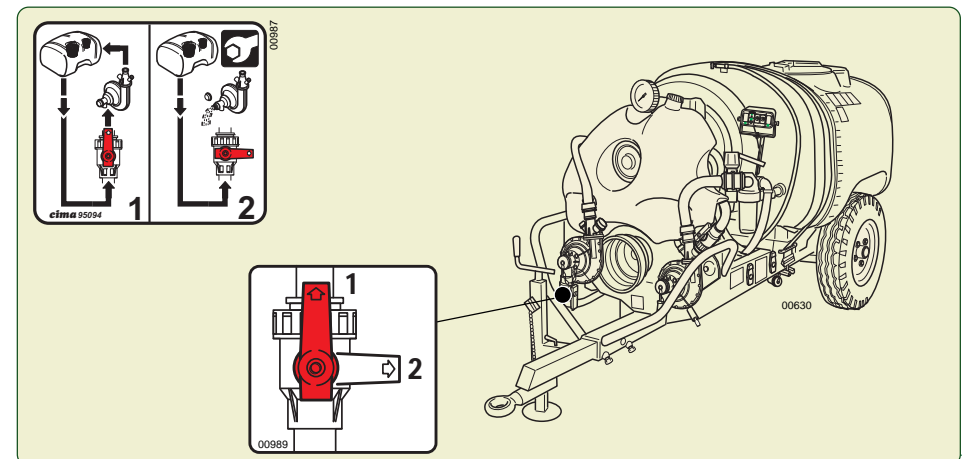

2 - Stop

On that position, the suction of the additional pump (P19) is closed to perform maintenance on the pump.

P12. POWDER MIXER LEVER TAP

(For versions in which his envisaged)

Positioned on the pipe (T6), between the main tank (P1) and the centrifugal pump (P4), it can assume the following positions:

a - Open

From the centrifugal pump (P4), the liquid is sent to the mixer positioned on the bottom of the cup-like filter of the main filler (BP).

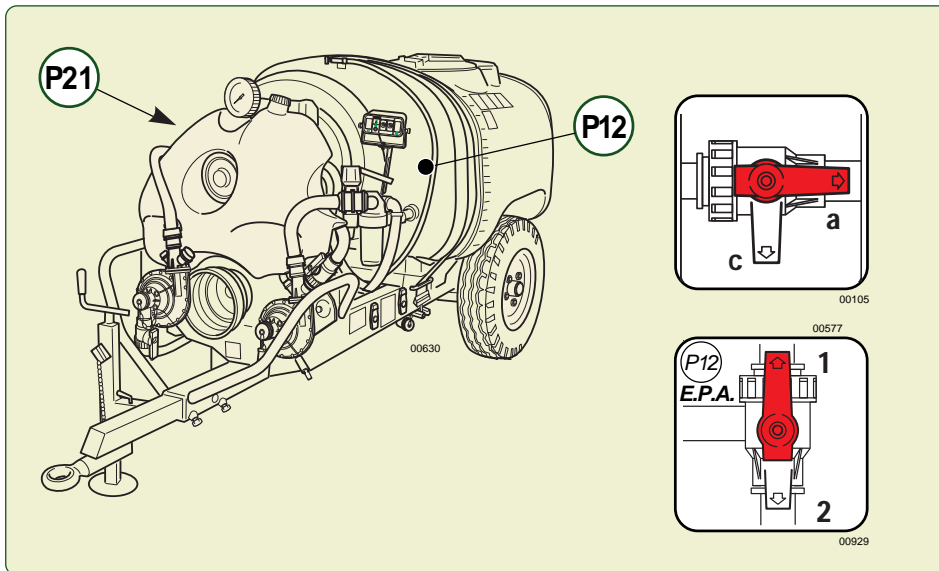
c - Closed

P12. POWDER MIXER THREE-WAY COCK (for E.P.A. versions only)

Situated on the delivery pipe (T8) of the agitation additional pump (P19), it can take on the following positions:

1 - Mixing

The liquid coming from the additional pump (P19) is sent to the mixer, which is situated on the bottom of the main filler (BP) cup filter.

2 - Agitation

The liquid coming from the additional pump (P19) is sent, through pipe (T9), directly into the main tank (P1) for the mixture hydraulic agitation.

The **hydraulic** and the **pneumatic** circuits mounted inside the tank, allow to realize a **double agitation system**: with the pump water and with the fan air, **at the same time**. The pneumatic circuit can be excluded, when the products used have a quite strong foaming effect, by closing the pneumatic agitator cock. When that cock is opened again, check that some air outlet holes aren't obstructed.



It is advised however to also use always the pneumatic agitator, adding to the mixture, if necessary, a antifoam product.



Before starting the treatment it is essential to agitate the mixture in the tank, re-circulating it completely for as long as it takes to make it homogeneous.



The agitation has to be carried out with the pressure regulator manual (P5) or electric (E5), completely open. Also the cock of the pneumatic regulator has to be open. This operation is of main importance, in order to get a uniform distribution of the active principle on the whole vegetative surface to be treated.

Should the activity need to be interrupted during a treatment with the sprayer, keep the agitator activated until the treatment is resumed. Should this be stopped and deferred to a later stage, the mixture that has remained in the tank must be **agitated again** properly.

THE MIXTURE AGITATION HAS TO BE CARRIED OUT WITH THE POWER TAKEOFF RUNNING AT A RATE OF AT LEAST 500 RPM.



Before using the atomizer fill the circuit-washer tank (if provided) and the hand-washer tank with clean water.

10.1 - PRELIMINARY OPERATIONS TO TREATMENT
• The operator must:

- a. Ascertain that the condition of the crops, the progress of the disease or the need for its prevention actually justify the treatment to be applied.
- b. Be aware of the meteorological conditions forecast for all the time necessary for carrying out the treatment.
- c. If possible, avoid carrying out the spraying in strong wind conditions or when one detects that the sprayed mixture disperses away from the target crop (drifting). It is advisable to suspend the treatment when the wind speed exceeds 3 m/s (10 km/hour). Should it be imperative to operate anyway, the following suggestions are made:
 - reduce the distance of the target from the spraying points, even if detrimental to the quality of the spraying
 - increase the dimension of the droplets, suitably adjusting the machine.
- d. Check that multiple-product mixtures be physically, chemically and biologically compatible amongst themselves; if need be, obtain the necessary information from the products' sales representative.



Properly tighten the nuts securing the mobile protection cover.

26. Start the tractor.
27. Engage the Power Takeoff and set it up to a running rate of at least 500 r.p.m., in order to carry out a further agitation.
28. Regulate the operating pressure, by acting on the pressure regulator hand regulator (P5) (or electric E5, for versions where provided) with the distributor, hand (P9) or electric (E9), open (DISTRIBUTION).
29. CARRY OUT THE TREATMENT (See the paragraph 11.3).

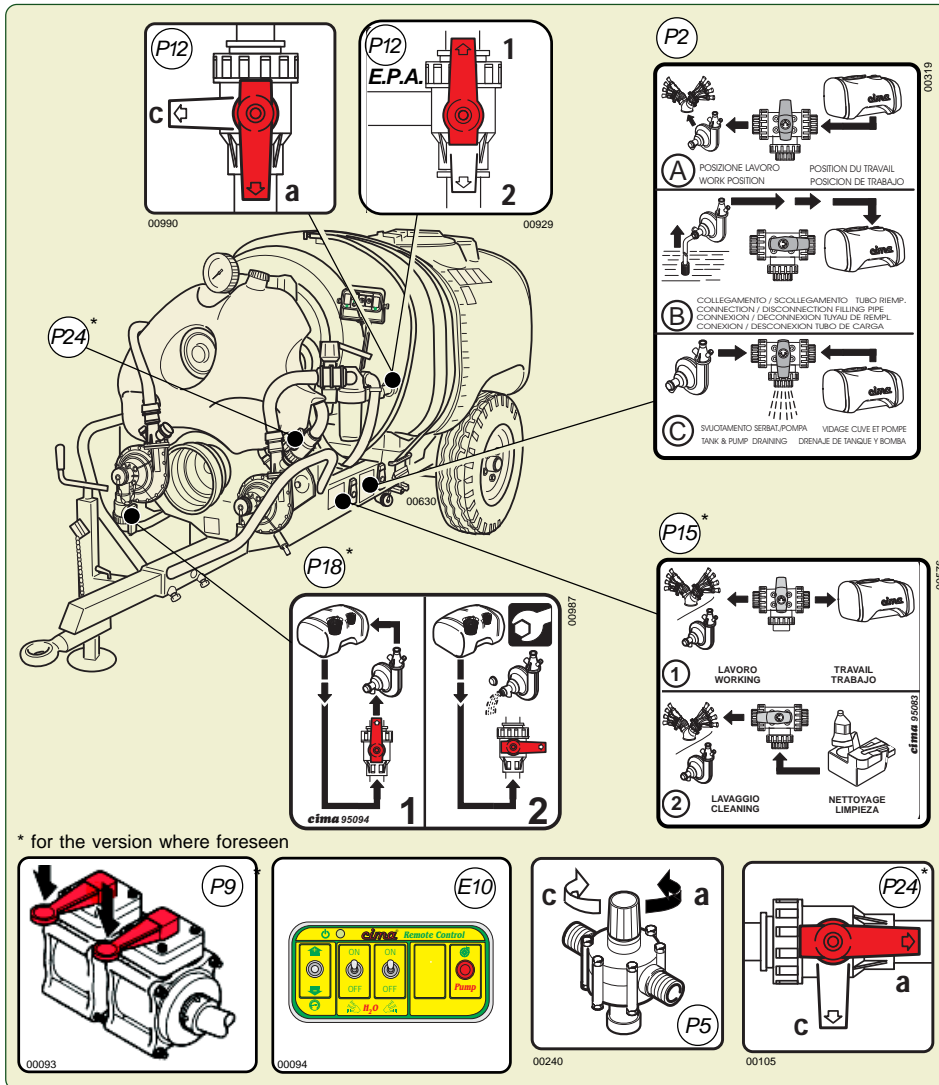

P21. NON-RETURN VALVE

Located on the suction pump (P4) and piping (T8/T9) of additional agitation to the tank and piping (T11) of force-feeding pump additional agitation (P19) in versions with 2 pumps.



The tap (P18) must be in position "1". The tap (P18) must be turned in position "3" ONLY when it is necessary to remove the pump (P19) with the main tank still containing liquid.

P24. 2nd DELIVERY OF MAIN PUMP EXCLUSION TAP

(Only for E.P.A. versions and versions with rinsing tank)

The tap is placed on the pipe (T11) of the second outlet of the main pump (P4) to the additional pump (P19). Should be left ALWAYS OPEN (positive "a"). The position "c" (closed) allows for washing of the circuit.

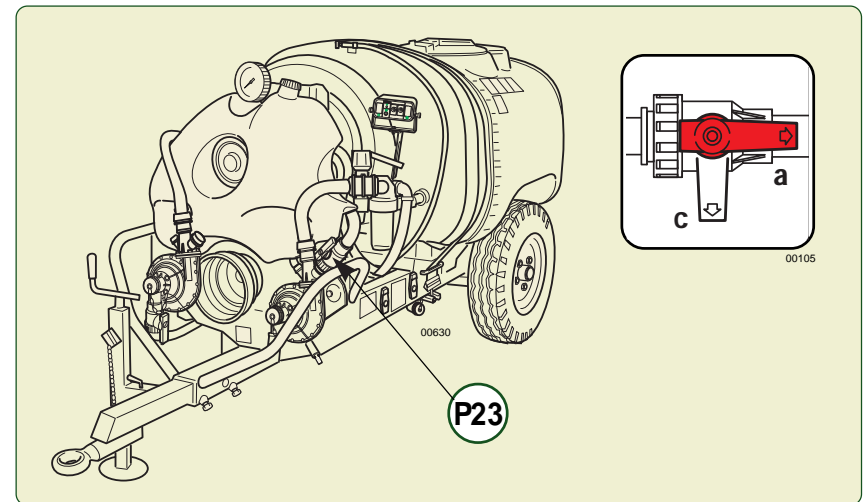

P17. SPRAY-LINE RINSING TANK (for the version where foreseen)

The polyethylene tank, with a capacity from 60 to 100 ltr. depending on the capacity of the main tank, is equipped with the filler and connection pipes to the hydraulic circuit of the sprayer.



When using the sprayer, keep the spray-line rinsing tank completely FULL of water: in this way the machine has a better stability.

P15. UNIT-WASHING 3-WAY LEVER TAP (For versions in which his envisaged)

Positioned on the pipe (T1), between the tank (P1) and the pump (P4), it connects the unit-washing tank (P17) to the main pump (P4) suction.

The 3-way tap (P15) lever can be placed in the following positions:

1 - Treatment (Work)

The fluid gets out from the tank (P1) and is sucked by the pump (P4); that is the **NORMAL** operation position, which is used in order to carry out the treatment and/or to keep the mixture. **The pipe connection to the unit-washing tank is closed.**

2 - Washing process

The fluid gets out from the unit-washing tank (P17) and is sucked by the pump (P4); that is the position which is used, in order to carry out the hydraulic circuit **WASHING**.



The unit-washing circuit allows to wash the hydraulic circuit (with the exclusion of the tank), in every moment and independently on the tank load conditions, i.e., also with the mixture present inside the tank.

When the tap (P15) is placed to position “2”, the clean water for the unit washing is taken from the unit-washing tank (P17), by simultaneously excluding the suction from the main tank. To avoid the clean water returns in the main tank, with a consequent dilution of the mixture, CLOSE COMPLETELY the manual regulator (P5), or the electrical one (E5), during the cleaning process.

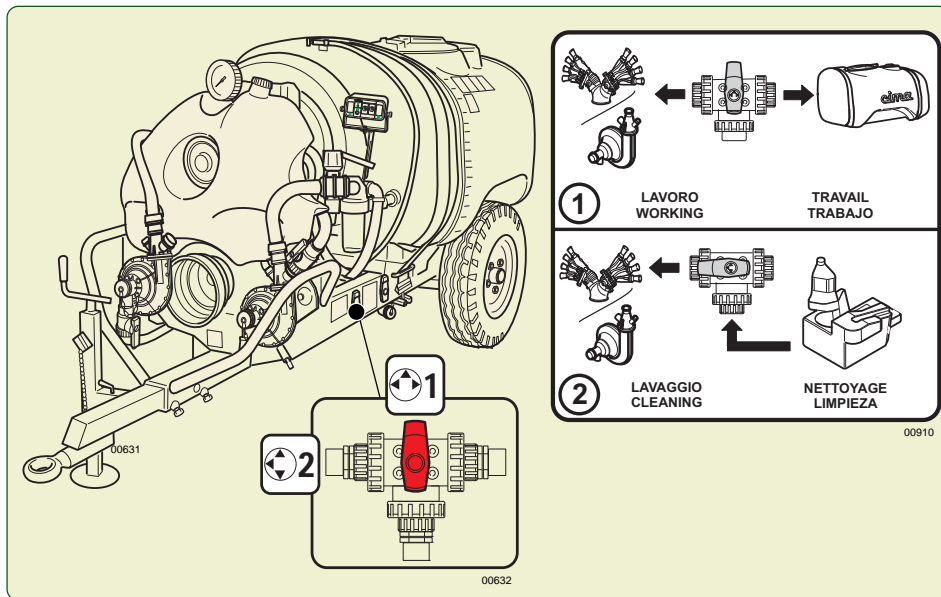

7. Close the cock (P12) by positioning the lever on “c”. (or position “2” for E.P.A. versions).
8. Completely close the pressure regulator, by turning clockwise th handle of the manual regulator (P5) or by turning the pressure up (keeping the joystick on “+” for about 15 seconds) if the atomizer is provided with electric regulator (E5).
9. Connect the filling pipe to the pump (P4).
10. Immerse the filter with the bottom-drawing valve in the water to be loaded.



The filter must always be below the level of the water to be loaded. The piping must never be above the pump’s suction point and must never be excessively bent in the vertical direction.

11. Position the lever of the 3-way cock (P2) to “A”.
12. Completely open the pressure regulator (P5), by rotating counterclockwise the handle of the hand regulator (P5) or by setting the pressure at zero (keep the joystick on “-” for about 15 seconds) if the atomizer is provided with electric regulator (E5).
13. Through the secondary filler (BS), pour into the tank about 15/20 litres of water: that quantity must be enough TO FILL the pipe and TO PRIME the pump (P4).
14. Start the tractor and engage the PTO; then bring it up to a 500 r.p.m. rotation rate.
15. When the pump will have started the recycling of the poured water, close the cock (P3), by positioning the lever to “B”, in order to start the filling through the return pipe (T3).

16a. WITH MEDICINE MIXTURES OR LIQUID PRODUCTS (WHEN NOT USING THE MIXER)

16a1. Pour the mixture of water and plant protection product previously prepared (or liquid product) foreseen for every loading (and the possible washing water for the medicine packs and for the instruments used for preparing the mixture) into the main filler (BP).

16a2. Close the main filler (BP) of the tank and wait until the filling is completed.

16b. WITH POWDER PRODUCTS, WHEN USING THE MIXER (IF FORESEEN)

16b1. Pour the dose of plant protection product in powder into the cup-like filter of the main filler (BP).

16b2. Close the main filler (BP) of the tank

16b3. Open the cock (P12) by positioning the lever on “a” (or position “1” for E.P.A. versions) and wait until the filling is completed.

16b4. Close the cock (P12) by positioning the lever on “c”. (or position “2” for E.P.A. versions).

17. Disengage the PTO.

18. Completely close the pressure regulator (P5), by turning clockwise the handle of the manual regulator (P5) or by setting the pressure at zero (keep the joystick on “+” for about 15 seconds) if the atomizer is provided with electric regulator (E5).

19. Remove the filling pipes from the pump (P4) and position again the closing plug.

20. Completely open the pressure regulator (P5), by rotating counterclockwise the handle of the hand regulator (P5) or by setting the pressure at zero (keep the joystick on “-” for about 15 seconds) if the atomizer is provided with electric regulator (E5).

21. Position the lever of the 3-way cock (P3) to “A”.

22. Engage the Power Takeoff and move to the treatment place, keeping the Power Takeoff running rate at least 500 RPM during all the operations of the treatment.

IN THE AREA OF THE TREATMENT:

23. Disengage the power take off (PTO).



Stop the tractor and remove the key from the control panel.

25. Make sure that the fan is stopped. Hook the fan to the servo amplifier as indicated at point 8.1, then mount back the release mobile protection cover.

- 10a2. Close the main filler (BP) of the tank.
 10a3. Complete the filling with water through the secondary filler (BS), **by keeping PTO in running.**
 10a4. Close the cover of the secondary filler (BS).
 10b. **WITH POWDER PRODUCTS, WHEN USING THE MIXER (IF FORESEEN)**
 10b1. Pour the powder medicine dose into the cup-like filter of the main filler (BP).
 10b2. Close the main filler (BP) of the tank.
 10b3. Open the cock (P12), by positioning the lever on "a" (or position "1" for E.P.A. versions).
 10b4. Complete the filling with water through the secondary filler (BS), by keeping PTO in running.
 10b5. Close the cock (P12), by positioning the lever on "c" (or position "2" for E.P.A. versions).
 11. Move to the place to be treated, by keeping the mixture agitation at a 500 r.p.m. PTO turning rate along the whole way.

FILLING DIRECTLY IN THE TREATMENT AREA:

12. Disengage the power take off (PTO)

13. **Stop the tractor and remove the key from the control panel.**

14. Make sure that the fan is still. Engage the impeller to the multiplier, as indicated at paragraph 8.1.b.



Tighten the protection-securing nuts properly.

15. Start the tractor.
 16. Engage the Power Takeoff and set it up to a running rate of at least 500 r.p.m., in order to carry out a further agitation.



Use ONLY the PTO at 540 rpm. Engage the PTO with the engine of the tractor at low speed and with maximum modularity, obtaining soft and progressive graft and avoiding abrupt starts of the cardan shaft.

17. Regulate the operating pressure, by acting on the pressure regulator (P5) (or electric E5, for versions where provided) with the distributor, hand (P9) or electric (E9), open (DISTRIBUTION).
 18. CARRY OUT THE TREATMENT (See the paragraph 11.3).

8.3 - FILLING WITH THE SPECIFIC PIPE

(optional on demand)



Before utilisation, check the operation and proper sealing of the bottom-drawing valve by pouring water in the piping.



THE PUMP MUST NEVER RUN DRY.

EXECUTION:

- Disengage the fan, see point 8.1.a.
- For the versions on which it is foreseen: check that the cock (P18) is open: (lever positioned on "1").
- For the version where foreseen: verify that the spray-line rinsing cock (P15) is on "1" position.
- Verify that the outlet on the faucet (P2) is closed by the special plug with chain.
- Position the lever of the 3-way cock (P2) to "B".
- Close the cocks of the 2-way distributor:
 - if electric (E9), position to "OFF" the quick-break switches on the electrical control panel (E10) or on the E.P.A. control unit.
 - if manual (P9), the levers are to be lowered (horizontally positioned):

P13. POWDER MIXER

(for the version where foreseen)

It makes the mixing of the powdery products during the filling of the tank. It is mounted on the basket filter of the main filler (BP) and it is connected to the pump (P4) by the pipe (T6). That device consists of a fine mesh-nylon basket, which is placed inside the tank main filler (BP). The basket is equipped with a mushroom outlet, through which the filling water coming from the pump (P4) streams out. Thanks to that system, the powder products contained inside the basket get more gradually dissolved, and the building of crums and thickenings can be avoided.

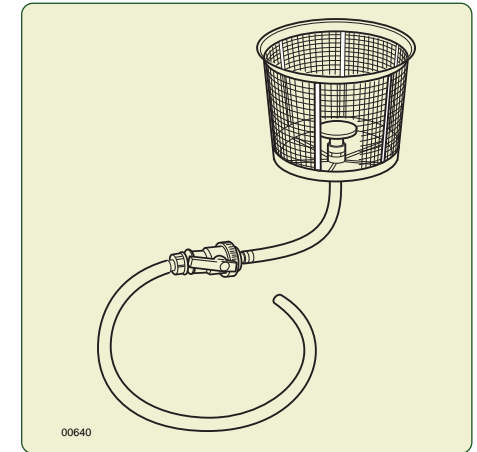

4.5 - TECHNICAL DATA

4.5.1 - Sprayer dimensions and weights

(Whith drawbar and protection ring - without didtribution device)

		Tank capacities (litres)				
		600	800	1000	1500	2000
BLITZ 45T	Total width (mm)	1020	1060	1380	-	-
	Total height (mm)	1300	1340	1370	-	-
	Total Lenght (mm)	3080	3350	3440	-	-
	Weight, empty (kg)	325	380	415	-	-
	Weight, full load (kg)	949	1204	1439	-	-
BLITZ 50T	Total width (mm)	1020	1060	1380	1550	-
	Total height (mm)	1300	1340	1370	1450	-
	Total Lenght (mm)	3180	3370	3570	4200	-
	Weight, empty (kg)	360	415	463	585	-
	Weight, full load (kg)	984	1261	1513	2150	-
BLITZ 55T BLITZ 55 TS BLITZ 55 TE	Total width (mm)	-	-	1450	1620	1800
	Total height (mm)	-	-	1420	1500	1730
	Total Lenght (mm)	-	-	3620	4350	4350
	Weight, empty (kg)	-	-	503	616	705
	Weight, full load (kg)	-	-	1553	2191	2805



Weight of steering drawbar standard kg 15,5, with 3-point connection kg 44,5: to be added to the weight of the sprayer, when it is used. The installation of the steering drawbar DOESN'T cause any variation of the machine total length. To calculate the total weight of the machine, sum the weight of the sprayer completely full of liquid, the weight of the sprayhead being used and the weight of the accessories eventually being installed.

4.5.2 - Wheels: dimensions and operating pressures

MODEL	MEASURE	WHEEL HUB	PRESSURE
BLITZ 45 600 - BLITZ 50 600	7,00-12-6PR	5 F	atm. 2,5
BLITZ 45 800 - BLITZ 50 800	7,00-12-6PR	5 F	atm. 2,5
BLITZ 45 1000 - BLITZ 50 1000	10/80.12-6PR	5 F	atm. 2,5
BLITZ 55-55S-55E 1000	10,0/75.15,3-8PR	6 F	atm. 3,3
BLITZ 45	10/80-12-8PR	5 F	atm. 3,3
BLITZ 50 1500	10/75-15,3-8PR	5 F	atm. 3,3
BLITZ 55-55S-55E 1500	10,0/75.15,3-8PR	6 F	atm. 3,3
BLITZ 55-55S-55E 2000	11,5/80.15,3-10PR	6 F	atm. 3,3

BLITZ2002

4.5.3 - Centrifugal Pump CD32

Model C.I.M.A. CD32 - Grid/filter on suction - Drain plug - Filler for the connection of the filling pipe, with plug with chain.

Activated with trapezoid belt driven by the pulley mounted on the fan shaft.

Technical data printed on the body of the pump.

— Speed	4250 RPM
— Flow rate	140 litres/min.
— Suction filter	7 mm
— Maximum pressure	4,5 Kg/cm ²
— Power absorbed	kW 2,5



The performance specified is obtained with the drive outlet (PTO) at 540 RPM. For a good result of the treatments this condition **MUST ALWAYS BE OBSERVED** during the machine's operation. Utilisation is permitted with speed rates ranging between 500 and 620 RPM



00832

8.1.b Fan engagement to perform the treatment

EXECUTION:

- Disengage the power take off (PTO)
- Stop the tractor, remove the key from the control panel and check that the fan is stopped.**
- Unscrew the nuts that fix the protection mobile cover and remove it to enter the release.
- Fully press the spring push button, push the front body forward, if necessary, turning it to the right or left, until the frontal teeth of the joint engage the corresponding teeth of the pulley; at the same time, the spring push button must return to the outward position. This way, the body is again integrated with the pulley, thus transmitting the movement to the fan.
- Reposition the mobile protection cover and suitably tighten the securing nuts.
- Start the tractor.

8.2 - FILLING THROUGH POURING FROM THE TOP



For this type of filling, use the supplementary filler (BS) located in the upper side of the tank, towards the rear of the sprayer.

THE INLET OF THE FILLER PIPING MUST NEVER COME INTO CONTACT WITH THE ANTI-PARASITIC MIXTURE: IT MUST ALWAYS BE KEPT AT A SAFE HEIGHT ABOVE THE TANK FILLER AND MUST BE EQUIPPED WITH A NON-RETURN VALVE.



THE PUMP MUST NEVER RUN DRY

EXECUTION:

- Disengage the fan (for the version where foreseen): see point 8.1.a.
- Verify that the lever of the 3-way cock (P2) it's in the position "A".
- For the version where foreseen: verify that the spray-line rinsing cock (P15) is on "1" position.
- Completely open the pressure regulator (P5), by rotating counterclockwise the handle or by setting the pressure at zero (keep the joystick on "-" for about 15 seconds) if the atomizer is provided with electric regulator (E5).
- For the versions on which it is foreseen: verify that the three-way cock (P18) lever of the additional agitation pump (P19) on "1"; make sure that the tap (P21) is open.
- Close the cocks of the 2-way distributor:
 - if electric (E9), position to "OFF" the quick-break switches on the control panel (E10) or on the control unit for E.P.A. versions;
 - if manual (P9), the levers are to be lowered (horizontally positioned);
- Close the cock (P12) by positioning the lever on "c". (on "2" position for E.P.A. versions).
- Pour some water into the tank, for about 1/3 of its capacity, by acting from the secondary filler (BS).
- Start the tractor and engage the PTO; then bring it up to a 500 r.p.m. rate.



Use ONLY the PTO at 540 rpm. Engage the PTO with the engine of the tractor at low speed and with maximum modularity, obtaining soft and progressive graft and avoiding abrupt starts of the cardan shaft.

10a. **WHEN NOT USING THE MIXER (WITH MEDICINE MIXTURES OR LIQUID PRODUCTS)**

- Pour the mixture of water and plant protection product previously prepared (or the liquid product) (and the possible washing water for the medicine packs and for the instruments used for preparing the mixture) into the main filler (BP).

FILLING MUST BE CARRIED OUT WITH THE MACHINE ON A FLAT SURFACE. ON THE SITE, BEFORE THE OPERATION, THE DOSES OR THE MIXTURES TO BE POURED INTO THE TANK MUST BE PREDISPOSED.





IT IS NECESSARY TO ALWAYS MAKE USE OF PERSONAL PROTECTION.

8.1 - FOREWORD - USE OF THE FAN DISENGAGEMENT

(for the version where foreseen)

8.1.a Disengagement of the fan

EXECUTION:

- 
 Stop the tractor, remove the key from the control panel and check that the fan has stopped.
- Unscrew the nuts that fix the protection mobile cover and remove it to enter the release tunnel.

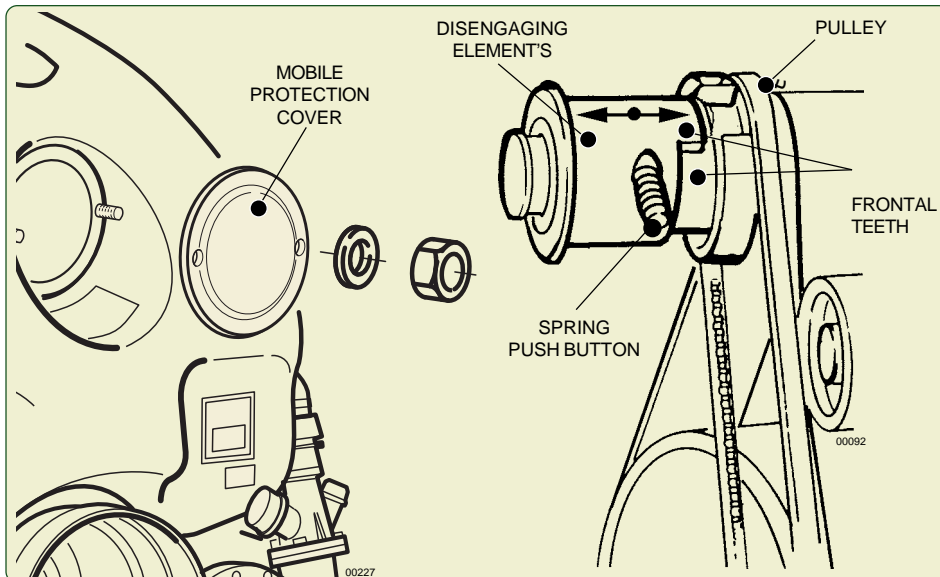

- Fully press the spring push button and pull the front element until it springs out. The body disengaged from the retaining joint must turn freely: the pump will operate and the fan will thus be excluded.
- Reposition the mobile protection cover and fasten the locking nuts properly.
- Start the tractor and carry out the filling operation.

5.1 - HITCHING TO THE TRACTOR



Check that the tractor "permissible trailed weight" is compatible with the sprayer weight, when this is fully loaded and complete with the equipments mounted for the treatment (see the Paragraphs "3.1" - "4.5.1" as well as the jointed documents).



THE TRACTOR'S POWER TAKE-OFF (PTO), UNDER ALL UTILISATION CONDITIONS, MUST PROVIDE A POWER EXCEEDING THAT ABSORBED BY THE SPRAYER.

Pairing suggested for tractors of at least	BLITZ 45	BLITZ 50	BLITZ 55	BLITZ 55 S	BLITZ 55 E
CV SAE	45	65	70	80	90
kW	33	48	52	58	66





BLITZ2005



The hitching has to be carried out on a plane surface, after having checked that all the people not charged with the operation moved away, as well as the children and the animals possibly present.

5.1.1 - Sprayer with standard drawbar

EXECUTION

- The tractor drawbar, if it is envisaged, has to be on central position.
- Drive the tractor near the sprayer and aligned with respect to it.
- 
 Stop the tractor and remove the key from the control panel.
- Select the trail eye position: either up or down.
The sprayer has to operate as horizontally as possible. If the ground allows it, intervene by regulating also the axle height.
- Position the drawbar trail eye at the height of the trail fork, by acting on the support foot.
- Start the tractor and insert the trail eye into the trail fork, by following the instructions supplied at preliminary notes.
- 
 Stop the tractor and remove the key from the control panel.
- Fasten the drawbar to the frame.
- Lock the drawbar, by inserting the special peg with safety clip pin.
- Lift the support foot and detach it from the drawbar.
- If necessary, regulate the drawbar length by fastening the support foot to the frame (Position B).
- By acting on the support foot, adjust its height, in such a way that it is possible to let the drawbar slide without any effort; remove the through bolt and loosen the two locking screws. Adjust the drawbar position, then lock it again.
- Lift the support foot and remove it from the frame.
- Fasten the support foot to the frame, on stowage position (Position C).



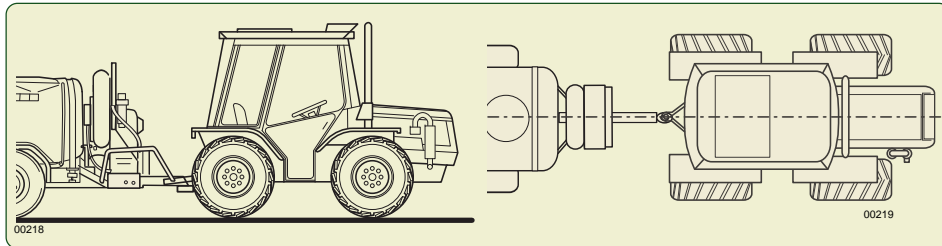

After every regulation, carefully tighten the screws and the bolt involved in the carried out operation.

12. After having properly fastened the fastening bracket supplied with the equipment, place the electrical control box (E8) or the manual control (P8) (for the version where foreseen) near the driver, inserting the power supply cable into the tractor plug.
13. Screw the two feeding pipes to the distribution device (head).



5.1.2 - Sprayer with steering drawbar

EXECUTION

1. Start the tractor and move it near the sprayer and aligned with it.
2.   **Stop the tractor and remove the key from the control panel.**
3. Extract pin (3), let the mobile body (4) advance and lock it on position by re-inserting pin (3);
4. Extract the pivot (1) of the tractor hook (5);
5. Introduce drawbar eye into the traction hook (5) and introduce again the locking pivot (1);
6. Fix the pivot by means of the relevant safety split pin (2);

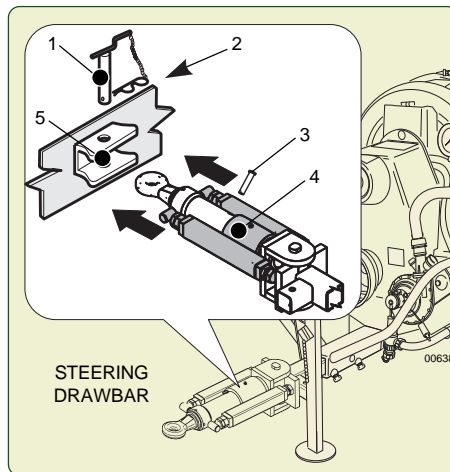

The steering drawbar can be locked in the two positions illustrated in the Figure:

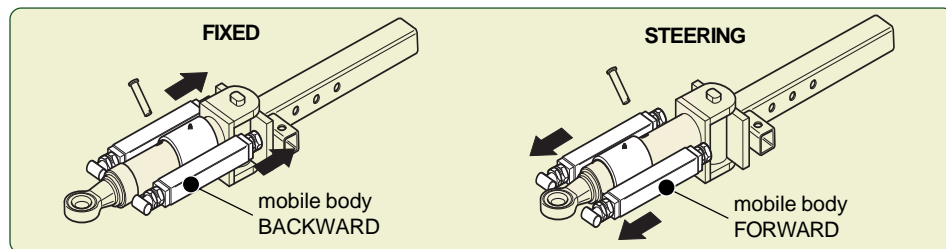

Drawbars for the coupling to the mechanical power lift

1. Insert the link quick balls on the pins of the machine, blocking them by the linch pins.
2. Hook the tie rod of the third point from the tractor to the sprayer.

7.6 - E.P.A. Kit - DELIVERY PROPORTIONAL ADVANCEMENT (for the version where foreseen)

The computerized E.P.A. system executes the monitoring of the distribution parameters for the active automatic control of the distribution proportional to the feed.

Through the constant takeover of the feed speed and the range of the product it is able to regulate the pressure continuously to keep the quantity of distributed product constant in relation to the treated surface.

The Kit is available in two versions:

- Version "Teejet® 76AB";
- Version "Teejet® 844AB."

Both versions are constituted from:

1. Magnetic induction proximity sensor (speed survey);
2. Pressure transducer (pressure survey);
3. Motorized electric valve (pressure regulation);
4. Computerized unit;
5. Dedicated printer ("Teejet® 844AB" version only).

For further information refer to the specific handbook.

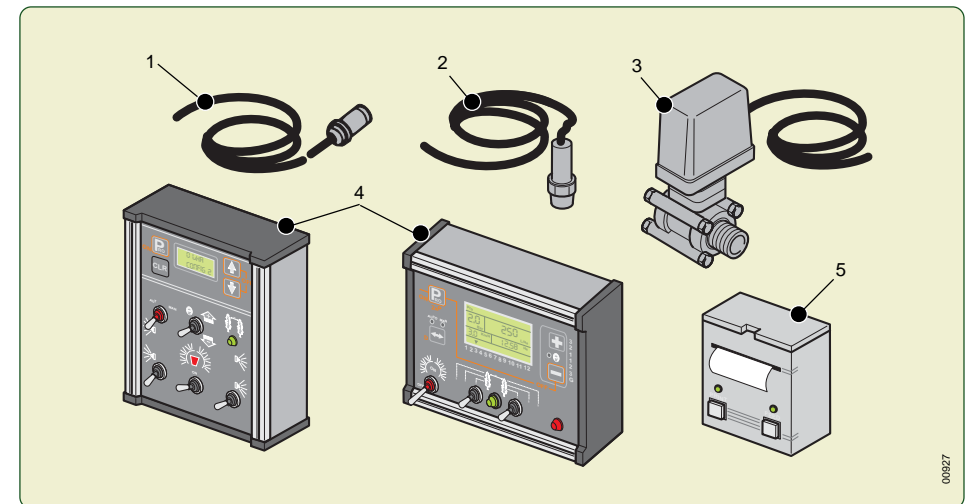

7.3 - ROTARY BLADES' HYDRAULIC MIXER (Patent n° 1295858)

(for the version where foreseen)

The mixer consists of a header, to which some oriented feed openings, equipped with mixing paddles, are applied. The mixer is mounted inside the tank through two hollow supports, a front and a rear one, which are equipped with bushes allowing it to rotate. The water coming from the additional pump is conveyed, through the supports, to the header and from that one to the oriented feed openings. The water streaming out causes, as a reaction, the mixer rotary movement, so adding to the mixture hydraulic agitation, the mechanical agitation caused by the paddles' movement.

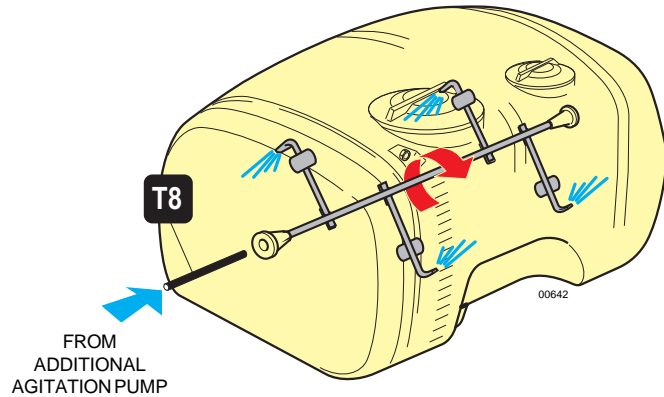

7.4 - REAR LIGHTS KIT

(for the version where foreseen)

The wired backlights kit is constituted by two complete back lights (parking lights, stop lights and direction indicators) and with hangers for the anchorage to the frame of the atomizer.

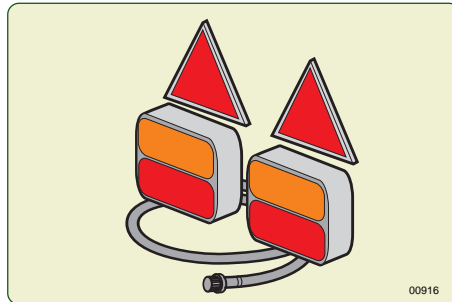

7.5 - PRESSURE ELECTROREGULATOR

(for the version where foreseen)

The pressure electroregulator can be installed in substitution of the manual regulator. The joystick for the electroregulator control is in the electric switchboard (E10).

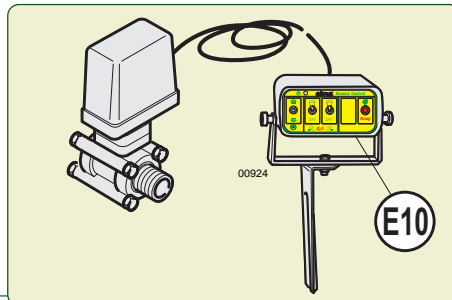

3. Screw the tie rod and put it under tension **N.B.:** lock the tie rod of the third point by the locking nut.
4. Lock the coupling by the chains of the arms of the mechanical power-lift.

5.2 MOUNTING OF THE TRANSMISSION SHAFT



The mounting, disassembling or possible other interventions on the transmission shaft must be carried out with the engine switched off and with the starter key removed from the tractor's control panel.



USE TRANSMISSION SHAFTS WITH CE CERTIFICATION.

OBSERVE THE REGULATIONS CONTAINED IN THE USE AND MAINTENANCE BOOK-LET PROVIDED BY THE SHAFT MANUFACTURER.

5.2.1 Cardan transmission shafts

The transmission shaft mounting has to be carried out when the 2 PTO are coaxial, or, shouldn't this be possible, when their axes are parallel. In this case, the misalignment has to be such to PREVENT the transmission shaft articulated joints to operate with an angle exceeding a 15° maximum width.

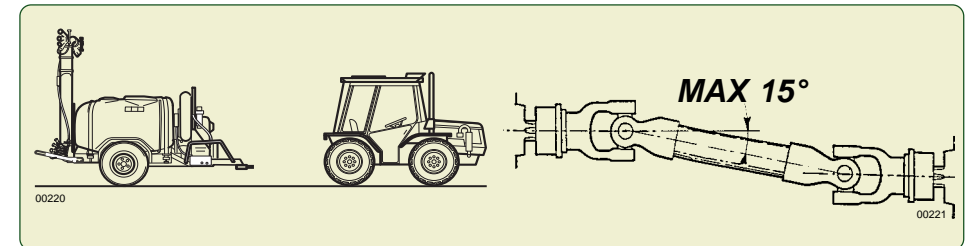

Those working positions can be reached by acting on the drawbar, which is adjustable both in height and in length.

When some curves are carried out with the power takeoff inserted, the steering angle can be 30° only if the trailing point is equally distanced with respect to the motion drives. Beyond such a value, it will be necessary to disengage the power takeoff, in order to avoid any possible breaks and dangers.

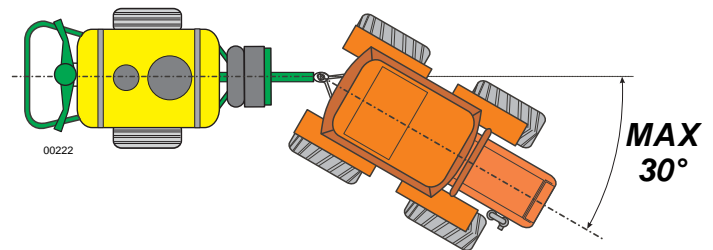

ANYWAY, THE USER HAS BOTH TO FOLLOW AND TO OBSERVE ALL THE INDICATIONS SUPPLIED IN THE USE AND MAINTENANCE BOOKLET PROVIDED BY THE CARDAN SHAFT MANUFACTURER.

DEFINITION OF THE TRANSMISSION SHAFT LENGTH.

1. After having hitched the sprayer to the tractor, set the operative unit to the maximum steering position allowed (without cardan shaft and with PTO disengaged).
2. Measure the distance "D" between the grooves of the two PTOs.
3. Length "L" of the transmission shaft (refer to the picture) to be deployed, measured between the 2 stopping pawls and with joint closed, must be 25 mm lesser than distance "D": " $L \leq D - 25 \text{ mm}$ ".

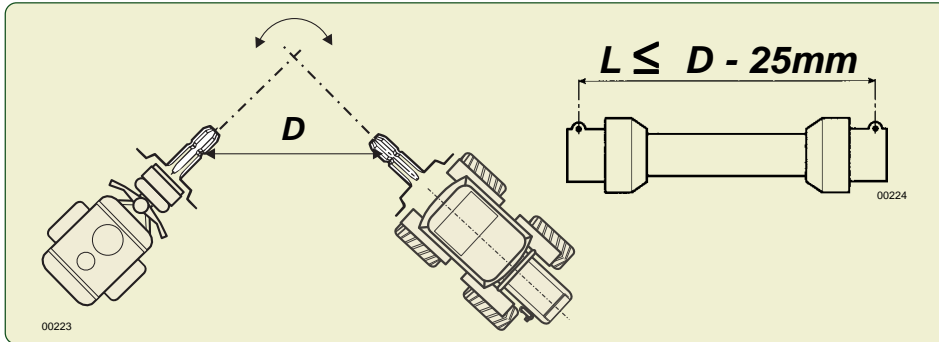
5.2.2 - Transmission with a single homocynetic joint (on the tractor side) for sprayers with steering drawbar

The transmission shaft mounting has to be carried out when the 2 PTO are coaxial, or, shouldn't this be possible, when their axes are parallel.

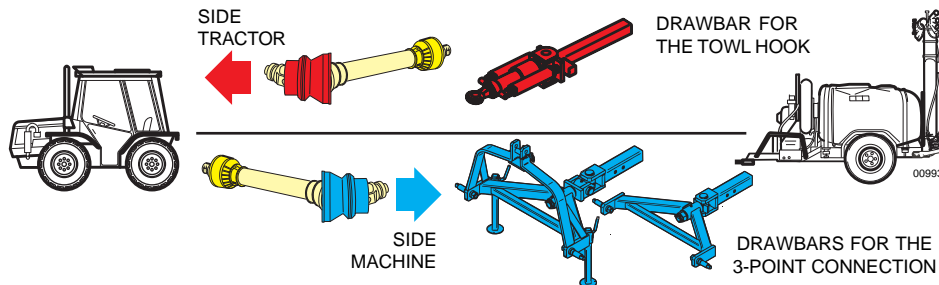

With drawbar for the tow hook the homocinetic joint **HAS TO BE MOUNTED ON THE TRACTOR PTO**, with drawbars for the 3-point connection the homocinetic joint **HAS TO BE MOUNTED ON THE SPRAYER PTO**. On these conditions, it is possible to carry out curves having a 70/80° steering angle, with the power takeoff turning.

ANYWAY, THE USER HAS BOTH TO FOLLOW AND TO OBSERVE ALL THE INDICATIONS SUPPLIED IN THE USE AND MAINTENANCE BOOKLET PROVIDED BY THE HOMOCYNETIC CARDAN SHAFT MANUFACTURER.

DEFINITION OF THE TRANSMISSION SHAFT LENGTH.

- Follow the same procedures described at Paragraph 5.2.1

7.1 - FILLER PIPE

The pipe is provided with a coupling elbow fitting and with a **bottom-drawing valve**. This is used for the filling of the tank.
It must be connected to the pump suction (P4) instead of the chain-held stopper.



The assembly has **ALWAYS** to be carried out with the lever of the cock (P2) positioned on "B".

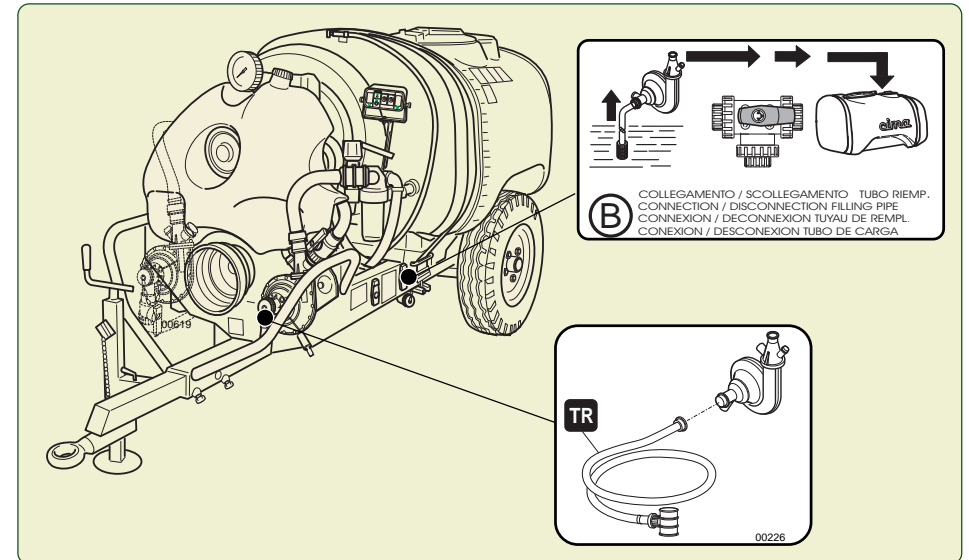

Before making use of it, it is necessary to check the operation and the proper sealing of the bottom-drawing valve, by pouring water into the pipe.

7.2 - ELECTRICAL TURN DEVICE

It is an accessory for modifying the direction of the spraying. It is used only with some types of distribution devices, spraying one side only.



All indications and instructions are provided in the "Distribution heads - Operation and maintenance instruction" booklet of the distribution devices with which it can be used.

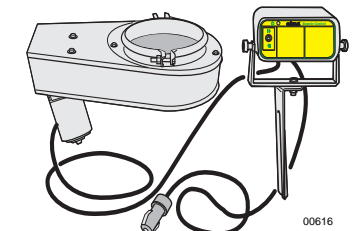

6.1 - ELBOW FITTINGS OF DISTRIBUTION DEVICES

The connection elbows both support and connect the distribution devices from the outlet of the connection tunnel, to the fan. The connection elbows are being supplied with the trailed sprayers Series BLITZ 45 and BLITZ 50, while for the trailed sprayers Series BLITZ 55, the connection elbows are being supplied with the distribution sprayhead.

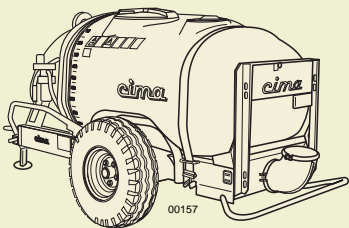
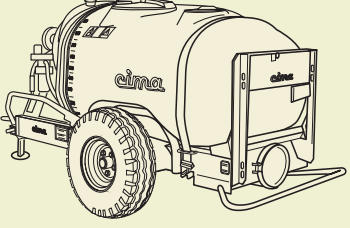
COMPLETE SERIES	BLITZ 45 - BLITZ 50	BLITZ 55 - 55S - 55E
Fan outlet opening	Inside diameter: 175 mm	Inside diameter: 250 mm
STANDARD BASIC MODELS		
Sprayers delivered:	90° ELBOW	WITHOUT ELBOW
Outlet opening	VERTICAL back	HORIZONTAL back



In the handbook "Distribution devices - Operation and maintenance instructions" the right type of elbow is indicated, together with the assembling instructions. A specific assembling diagram of each type of sprayhead is also supplied with the spare parts catalogue.

5.3 - INSTALLATION OF REMOTE CONTROLS

5.3.1 - Electrical control panel - E10

1. Fix the fastening bracket near to the driver (if not already available on the tractor).
2. Insert the bayonet support of the control panel in the securing clamp.
3. Connect the distribution piping (T5) to the hydraulic circuit of the distribution device (head) mounted on the machine (follow the instructions of the specific "use and maintenance" book-let which is supplied with it).
4. Connect the feeding pipe (T4) with the electrical distributor (E9).
5. Connect the power supply cable "W1" plugging it in the socket of the tractor.

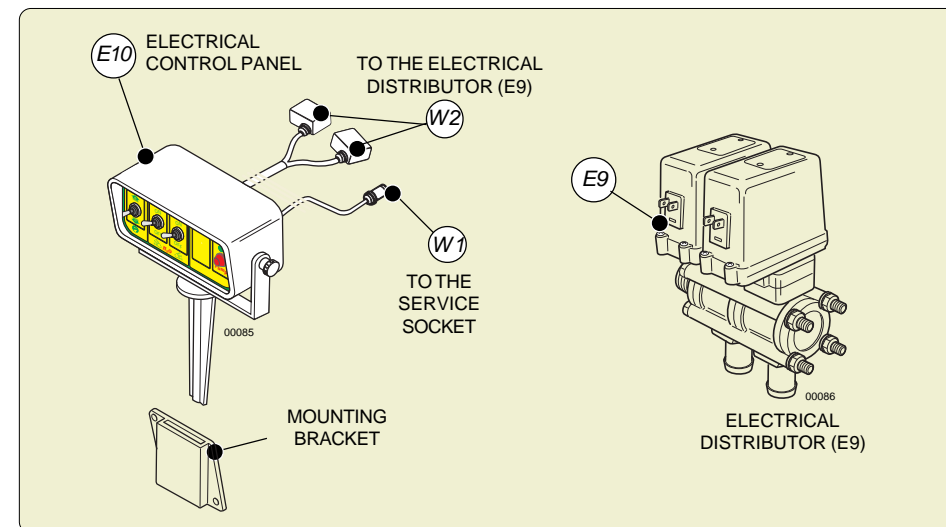

Position the electrical cables W1 and W2 in such a way as to avoid risking their being wrenched off during treatments. If necessary, use some securing clamps. A sudden interruption of power will lock the 2 solenoid valves of the electrical distributor "E9". Should this fault take place when they are in the open position, it is necessary to:

- Stop the tractor and remove the key from the control panel.
- Position the cock (P2) to "3".
- Restore the electric current.

INCASE OF A PIPE BURST:

- 1 - Stop the tractor and remove the key from the control panel.
- 2 - Close the electrovalves (E9), the switches on the control panel (E10) must be on OFF.
- 3 - Close the pressure regulator (P5) turning clockwise the pressure regulation knob or keep the joystick (E10) in position "+" for at least 15 seconds on the electrical control box.
- 4 - Replace the broken pipe (for the elimination of these parts, please follow the current regulations).

5.3.2 - Manual 2-tap distributor - P9 (for the versions where foreseen)

- 1 - Mount the fastening bracket on the tractor within the driver's reach (if this is not already present on the tractor).
- 2 - Insert the distributor's bayonet support in the securing bracket.
- 3 - Connect the feeding pipe (T4)
- 4 - Connect the distribution piping T5 to the hydraulic circuit of the distribution device (head) mounted on the machine (follow the instructions of the specific "use and maintenance" book-let which is supplied with it).

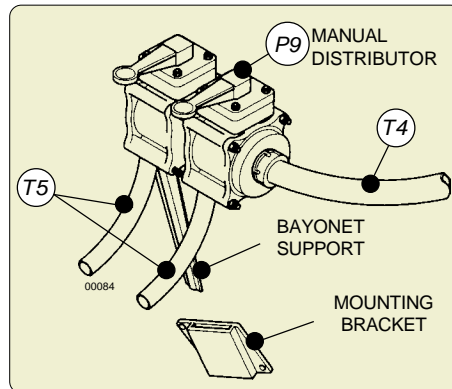

Position the distribution piping T5 and feed piping T4 so as to avoid the risk of suffering damage or breakage during spraying. It may be needed to shorten the pipes.

IN CASE OF BREAKAGE:

- 1 - Stop the tractor and remove the key from the control panel.
- 2 - Close the 2 taps of distributor (P9).
- 3 - Move the 3-way cock (P2) lever to position "3", filling.
- 4 - Close the cock with pressure regulating handgrip (P5) (turn it clockwise).
- 5 - Repair or replace the broken pipes (for the elimination of these parts, please follow the current regulations).

5.3.3 - E.P.A. Control Unit



Act in a similar way as indicated for installing the electric control power plant (E10) (see Paragraph 5.3.1.)



Position the electric cables in such a way to prevent them from getting torn during the treatment.

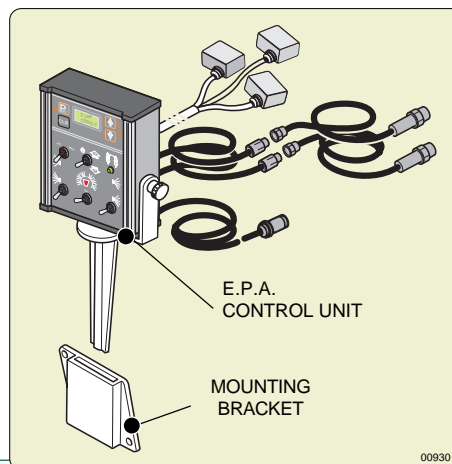

6 DISTRIBUTION DEVICES 6



Every distribution device is supplied with its own USE AND MAINTENANCE booklet that is, or will have to be, attached to this publication and will constitute one of its integral parts.

The "Distribution devices – Operation and maintenance instructions" manual both shows and describes the wide range of the distribution devices (heads), to be employed on each sprayer in order to assure a perfect covering, always answering to the real requirements of the culture to be treated. All the heads can be very easily oriented and regulated, so to optimise the necessary covering.

Simple heads

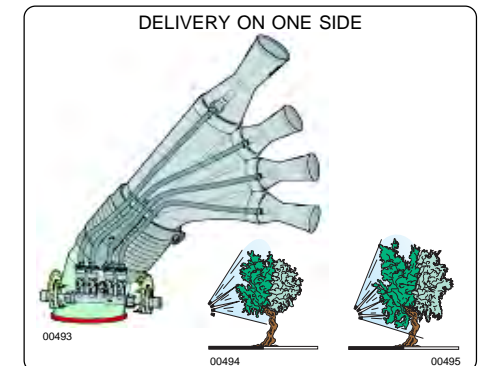
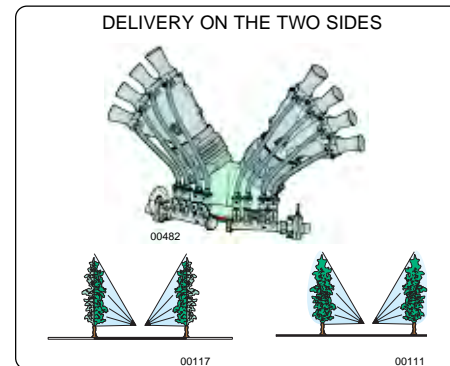

Combined heads

