



**BLITZ**

## OPERATION AND MAINTENANCE INSTRUCTION

**cima**® S.p.A.

27040 Montù Beccaria - Loc. Molino Quaroni - (PV) - ITALIA  
Tel. +39.0385.246636 r.a. - Fax +39.0385.246637  
<http://www.cimaitalia.com>

**cima**®

**atomizzatori e impolveratori**

*Dear Customer, thank you very much!*

*We want to congratulate with you, for having chosen a **cima**® sprayer.*

*Your choice shows the wisdom of the well-informed Purchaser, aware of the fact, that the required features of quality, technique and reliability must be satisfied at the right price!*

*Our continuous engagement in R&D and in testing our machines allows us to realize products able to offer the best performances, a high reliability and a great easiness of use at the same time !*

*Our first goal, is to get our Customers happy for having met us!*

The "Spare parts catalogue" of this sprayer/sprayhead is available in the "restricted area" on website [www.cima.it](http://www.cima.it).

In order to accede, use:

Username: **sprayer**

Password: **844719KE**

Where we are



# LOW-VOLUME SPRAYERS TRAILER-MOUNTED MODELS

## BLITZ

Model: .....

Serial Number: .....

## OPERATION AND MAINTENANCE INSTRUCTIONS

***cima***<sup>®</sup> S.p.A.

27040 Montù Beccaria - Loc. Molino Quaroni - (PV) - ITALIA

Tel. +39.0385.246636 r.a. - Fax +39.0385.246637

<http://www.cimaitalia.com>



## LISTING OF VALID PAGES

This publication consists of 65 pages, subdivided as follows:

N° OF PAGE	REVISION	BASE
from I to VI	02	January 2002
from 1 to 59	02	January 2002

## ADDITIONAL RECORDS AND VARIANTS

REVISION	DESCRIPTION
00	First Edition, May 1996
01	Second Edition, November 2001
02	Third edition, January 2002
03	
04	
05	
06	
07	
08	

GENERAL INDEX

**1 FOREWORD** ..... 1

1.1 PUBLICATION IDENTIFICATION ..... 1

1.2 ATTACHED PUBLICATIONS ..... 1

1.3 PURPOSE OF PUBLICATION ..... 1

1.4 REFERENCE TO REGULATIONS ..... 1

1.5 USING THE MANUAL ..... 1

1.6 UPDATES ..... 2

**2 GLOSSARY** ..... 3

2.1 TERMINOLOGY ..... 3

2.2 ABBREVIATIONS ..... 3

2.3 DECALS ..... 3

**3 GENERAL INFORMATION** ..... 8

3.1 MACHINE IDENTIFICATION ..... 8

3.2 TECHNICAL ASSISTANCE ..... 8

3.3 SAFETY NOTICES ..... 8

3.4 SAFETY SYSTEMS ..... 9

3.5 HANDLING OF AGRO-CHEMICALS ..... 10

3.5.1 Storage ..... 10

3.5.2 Specific equipment ..... 10

3.5.3 Disposal of empty containers and agro-chemical residues ..... 11

3.5.4 Personal means of protection ..... 11

**4 MACHINE'S STRUCTURAL ANALYSIS** ..... 12

4.1 FRAME WITH DRAWBAR ..... 13

4.2 FRAME WITH STEERING DRAWBAR ..... 16

4.3 FAN SERVO AMPLIFIER ..... 17

4.4 HYDRAULIC CIRCUIT COMPONENTS ..... 18

4.5 TECHNICAL DATA ..... 25

4.5.1 Sprayers dimensions and weights ..... 25

4.5.2 Wheel's: dimensions and operating pressures ..... 25

4.5.3 Technical specifications for fans and pump ..... 26

**5 COUPLING MODALITIES** ..... 27

5.1 HITCHING TO THE TRACTOR ..... 27

5.1.1 Sprayers with standard drawbar ..... 27

19 ATTACHMENT: DECLARATON OF CONFORMITY 19

**cima®**

**DICHIARAZIONE DI CONFORMITÀ** CE  
ai sensi della direttiva 98/37/CE del 22/06/98 e successive modificazioni

<b>DECLARATION OF CONFORMITY</b> as directive 98/37/CE - 22/06/98 and subsequent modifications <span style="float: right;">CE</span>	<b>DECLARATION DE CONFORMITE</b> selon la directive 98/37/CE - 22/06/98 et modifications ultérieures <span style="float: right;">CE</span>
<b>ÜBERREINSTIMMUNGS-ERKLÄRUNG</b> II. Direktiven 98/37/CE - 22/06/98 und nachfolgenden Änderung <span style="float: right;">CE</span>	<b>DECLARACION DE CONFORMIDAD</b> con arreglo a la Directiva 98/37/CE - 22/06/98 y modificaciones siguientes <span style="float: right;">CE</span>

**CIMA s.p.a. 27040 MONTÙ BECCARIA (PV) - ITALY - Loc. Molino Quaroni**

DICHIARA SOTTO LA PROPRIA RESPONSABILITÀ CHE LA MACCHINA	HEREWITH DECLARES, UNDER THEIR PERSONAL RESPONSIBILITY, THAT THE FOLLOWING MACHINE	DECLARONS SOUS NOTRE RESPONSABILITÉ QUE LA MACHINE DESERTE CHAMPÉE	ERSTÄTTET HIERMIT UNTER MEINER PERSÖNLICHEN VERANTWORTUNG DAS DIE MASCHINE	DECLARA BAJO LA PROPIA RESPONSABILIDAD QUE LA MAQUINA
---	--	---	--	--

SERIE, TIPO - MODEL, TYPE - SERIE, TYPE - MODEL, TYPI - SERIE, TIPO:

MATICOLA SERIAL MATRICOLI F SERIAL MATRICOLI A NR.:

È conforme ai Requisiti essenziali di Sicurezza e di Tutela della Salute di cui alla Direttiva 98/37/CE del 22/06/98 e sue successive modificazioni.  
Per la verifica della Conformità di cui alla Direttiva 98/37/CE sono state consultate le seguenti Norme armonizzate: **EN 294 EN 349 EN 907**

Conforms to the essential Safety regulation as well as the Health requirements as per European Economic Community Directive: 98/37/CE - 22/06/98 and subsequent modifications. For the verification of conformity as per above mentioned directives the following official EN norms have been consulted: Harmonized norms: <b>EN 294 EN 349 EN 907.</b>	Est conforme aux exigences de Sécurité et de Santé de la Santé dont à la Directive 98/37/CE - 22/06/98 et modifications ultérieures. Pour vérifier la conformité aux directives susmentionnées, ont été prises en compte les normes suivantes: Normes harmonisées: <b>EN 294 EN 349 EN 907.</b>
Stimmt mit den wesentlichen Requisition der Sicherheit vorzuschritten und der Gesundheitsvorsorge lt. EWG Direktive Nr. 98/37/CE - 22/06/98 und nachfolgenden Änderung überein. Für die Überprüfung dieser Übereinstimmungs-Übersicht lt. obigen Direktiven sind folgende Normen konsultiert worden: Normen: <b>EN 294 EN 349 EN 907.</b>	Cumple con los requisitos esenciales de Seguridad y de Preservación de la Salud contenidos en la Directiva 98/37/CE - 22/06/98 y modificaciones siguientes. Para comprobar la conformidad a la que se refieren las Directivas anteriormente citadas, se han consultado las siguientes: No más Armonizadas: <b>EN 294 EN 349 EN 907.</b>

Responsabile della Sicurezza - The Safety Officer - Responsable Sécurité et Santé - Der Fachbeauftragte - Responsable de Sécurité

Molino Quaroni (PV)  
Data, Day, Month, Year, Hour: \_\_\_\_\_

*Smeraldi Paolo*  
*Amaldi Paolo*

**17 NOISE LEVEL 17**

Spray atomiser model	L qA - dB(A)
BLITZ 45T	92,0 ± 0,2
BLITZ 50T	93,0 ± 0,2
BLITZ 55T	95,4 ± 0,2
BLITZ 55TS	95,4 ± 0,2
BLITZ 55TE	95,4 ± 0,2

BLITZ009

**18 WARRANTY 18**



**THE OWNER AND/OR THE OPERATOR OF THE SPRAYER ARE NOT PERMITTED TO MODIFY THE STRUCTURE OR THE SPECIFIC OPERATION OF THE SPRAYER ITSELF. ANY REPAIRING INTERVENTION HAS TO BE CARRIED OUT EITHER AT THE DISTRIBUTORS' OR AT THE C.I.M.A. S.p.A. AUTHORIZED WORKSHOPS, OTHERWISE ANY KIND OF WARRANTY IMMEDIATELY CEASES AND C.I.M.A. S.p.A. IS CLEARED OF ANY CONSEQUENT AND/OR IMPLIED RESPONSIBILITY.**

The machines are guaranteed for **12 months** from the delivery date. During this period, spare parts not subject to wear and tear and confirmed as defective will be replaced free of charge, not including of transport and labour expenses.

The warranty will be void:

- a. should repairs be carried out without the consent of the manufacturer or one of its sale points.
- b. should original spares not be used.
- c. should the machine be used for purposes other than those for which it was specifically designed and destined.
- d. should the instructions of this manual, together with those relating to the integrative parts that make it up, not be observed.

- 5.1.2 Sprayer with steering drawbar ..... 28
- 5.2 MOUNTING OF THE TRANSMISSION SHAFT ..... 28
- 5.2.1 Cardan transmission shafts ..... 29
- 5.2.2 Transmission with a single homocynetic joint (on the machine side) for sprayers with steering drawbar ..... 30
- 5.3 INSTALLATION OF REMOTE CONTROLS ..... 30
- 5.3.1 Manual 2-tap distributor - P8 ..... 30
- 5.3.2 Electrical control panel - E8 ..... 31
- 6 DISTRIBUTION DEVICES ..... 32**
- 6.1 TYPE AND IDENTIFICATION CODES ..... 32
- 6.2 ELBOW FITTINGS OF DISTRIBUTION DEVICES ..... 33
- 7 ACCESSORIES ..... 34**
- 7.1 FILLER PIPE ..... 34
- 7.2 ELECTRICAL TURN DEVICE ..... 34
- 7.3 VANE-TYPE MECHANICAL AGITATOR ..... 34
- 8 FILLING ..... 35**
- 8.1 FOREWORD – USE OF THE FAN DISENGAGEMENT ..... 35
- 8.1.a Disengagement of the fan ..... 35
- 8.1.b Fan engagement to perform the treatment ..... 36
- 8.2 FILLING THROUGH POURING FROM THE TOP ..... 36
- 8.3 FILLING WITH THE SPECIFIC PIPE ..... 37
- 9 AGITATION ..... 40**
- 10 TANK AND HYDRAULIC CIRCUIT DRAINING ..... 40**
- 11 OPERATING PROCEDURES ..... 41**
- 11.1 PRELIMINARY OPERATIONS TO TREATMENT ..... 41
- 11.2 PREPARATORY OPERATIONS TO TREATMENT ..... 41
- 11.3 THE TREATMENT ..... 43
- 11.4 END OF TREATMENT - STORAGE ..... 43
- 11.4.1 Daily ..... 43
- 11.4.2 End of seasonal cycle ..... 44
- 12 LIFTING AND TRANSPORT ..... 45**

<b>13</b>	<b>MAINTENANCE OPERATIONS</b> .....	<b>46</b>
13.1	LUBRICATION .....	46
13.2	FAN SHAFT SUPPORT OIL LEVEL CHECK .....	47
13.3	FAN SHAFT SUPPORT OIL REPLACEMENT .....	48
13.4	CLEANING OF FILTER'S CARTRIDGE .....	48
13.5	CLEANING OF THE FAN .....	48
13.6	FAN BELT TENSIONER .....	49
13.7	PUMP BELT TENSIONER .....	50
13.8	TANK REMOVAL OR REPLACEMENT .....	50
13.9	TABLE OF MAINTENANCE OPERATIONS .....	51
<b>14</b>	<b>FAULTS FINDING</b> .....	<b>52</b>
<b>15</b>	<b>REPAIRS ALLOWED</b> .....	<b>54</b>
15.1	REPLACEMENT OF PUMP CONTROL BELT .....	54
15.2	REPLACEMENT OF ELECTRICAL PANEL'S FUSES .....	55
15.3	PRESSURE GAUGE REPLACEMENT .....	55
<b>16</b>	<b>INTEGRATIVE DIAGRAMS</b> .....	<b>56</b>
16.1	HYDRO-PNEUMATIC DIAGRAM .....	56
16.2	WIRING DIAGRAM .....	57
<b>17</b>	<b>NOISE LEVEL</b> .....	<b>58</b>
<b>18</b>	<b>WARRANTY</b> .....	<b>58</b>
<b>19</b>	<b>ATTACHMENT : DECLARATION OF CONFORMITY</b> .....	<b>59</b>

**16.2 - WIRING DIAGRAM**

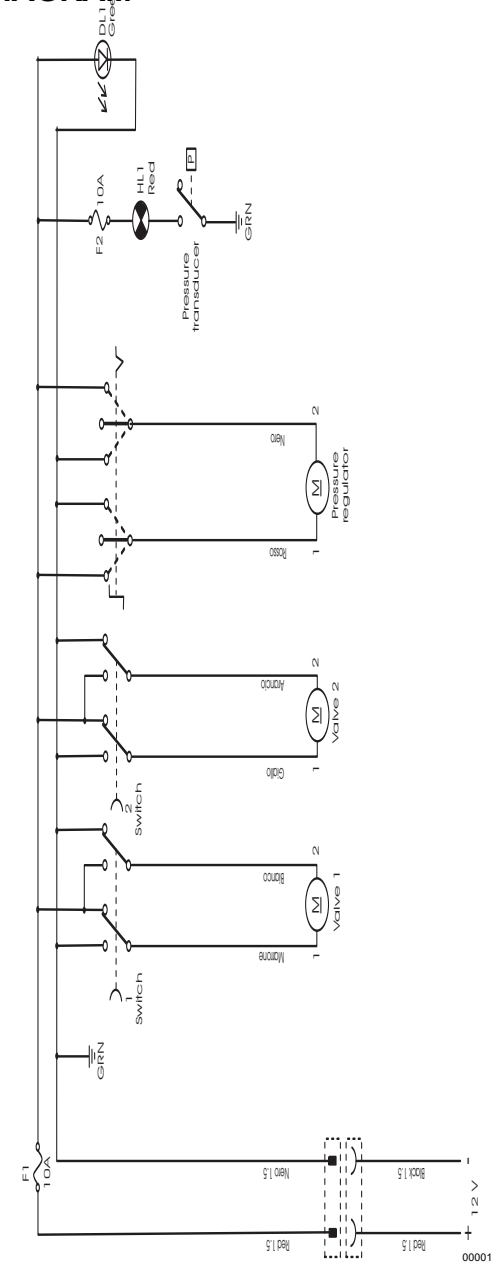



16.1 - HYDRO-PNEUMATIC DIAGRAM

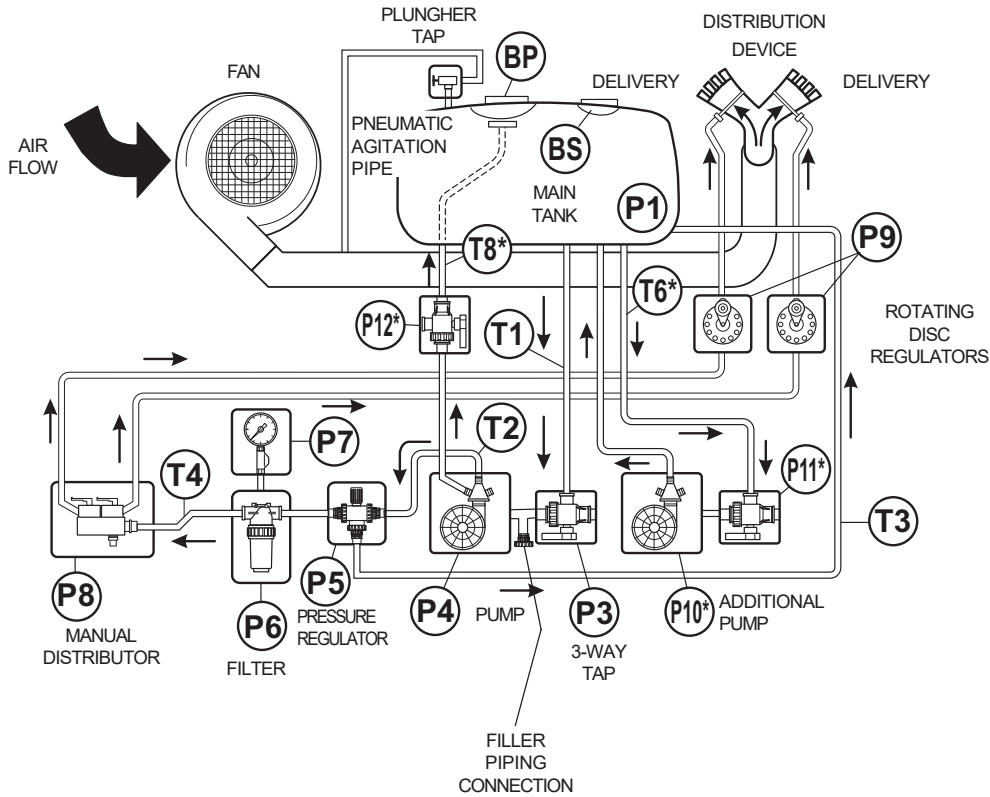

\* For the version in which it is envisaged

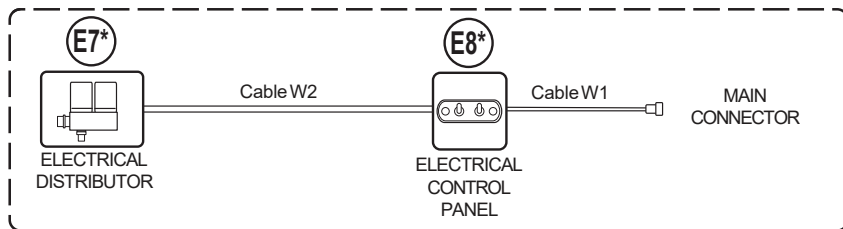

00242

1.1 - PUBLICATION IDENTIFICATION

The "OPERATION AND MAINTENANCE INSTRUCTIONS" manual is an integrative part of the sprayers. It is identified by a Publication No. located on the third cover page, and through which the document can be identified, traced and/or subsequently referred to. The information elements contained herein are updated as at the date of publication. C.I.M.A. S.p.A. reserves the right to modify its machines without notice, with the purpose of applying technical enhancements, and it declines all responsibility for possible omissions from the publication.

1.2 - ATTACHED PUBLICATIONS

- Spare parts catalogue;
- Distribution devices, "Operation and maintenance instruction"
- Distribution devices, "Spare parts catalogue"
- "Low Volume - Instructions for sprayer adjustment"
- "Modalities for filling through the specific pipe" diagram
- "Modalities for filling through pouring from the top" diagram

1.3 - PURPOSE OF PUBLICATION

All indications contained in this manual are aimed at the user of the sprayer. The duration of the machine and its operation, the operator's safety and the respect for the environment are dependent upon scrupulous observance of the stated norms. Before making use of the sprayer, the user must read, understand and abide by all regulations listed in this manual.

1.4 - REFERENCE TO REGULATIONS

This manual was set out conforming to the regulations contained in following documents:  
 — Attachment "I" to Directive 89/392/C and subsequent modifications (letters "b", "c" of point 1.1.2 and point 1.7.4);  
 — UNI EN 907 - 1997 and to all the documents in it quoted.

1.5 - USING THE MANUAL

Read every part of this manual, paying attention to the **WARNING** and **DANGER** indications both on the text and on the machine or on components. All operations suggested by the manual will have to be followed with the utmost care and only after having understood the negative consequences of improper usage.

The following "symbols " are used within the text in order to highlight and visually identify the importance of the various types of information:



Indicates important additional information



Non observance can result in permanent damage to the sprayer.



Highlights possibly dangerous situations to people.

The manual, with relevant attachments and possible integrating issues, must be kept with the utmost care and must always be complete, integer and legible in every part. Should it be mislaid it is imperative to immediately request a duplicate from C.I.M.A. S.p.A. Should the decals originally applied on the machine be mislaid, damaged or become incomprehensible, they should be promptly replaced.

For every type of distribution device (Head) delivered with the sprayer, a specific user and maintenance manual is attached. All the head manuals must always accompany the one of the machine.



- The manual must always be kept for the sprayer's whole operational life.
- Any modification received must be permanently inserted in this publication.
- The manual must be ceded with the sprayer should this be sold.

## 1.6 - UPDATES

Possible updates that C.I.M.A. S.p.A. will provide the owner of the sprayer will be accompanied by instructions to insert in this publication.

Should the machine be sold, the owner must inform the new purchaser that he should notify C.I.M.A. S.p.A. of his address in order to receive possible future integrating issues and/or updates.

## 15.2. - REPLACEMENT OF ELECTRICAL PANEL'S FUSES



Stop the engine and remove the ignition key from the tractor's control panel.

1. Undo the fuse-carrier cover;
  2. Replace the faulty fuse and screw back the cover.
- Fuse: 1.25 A, delayed.

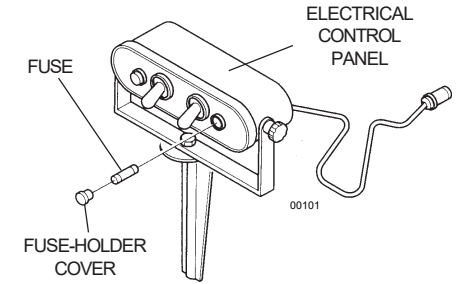

## 15.3. - PRESSURE GAUGE REPLACEMENT



Stop the motor and remove the starting key from the tractor control panel.

1. Unscrew and remove the defective pressure gauge ;
2. Replace the pressure gauge.

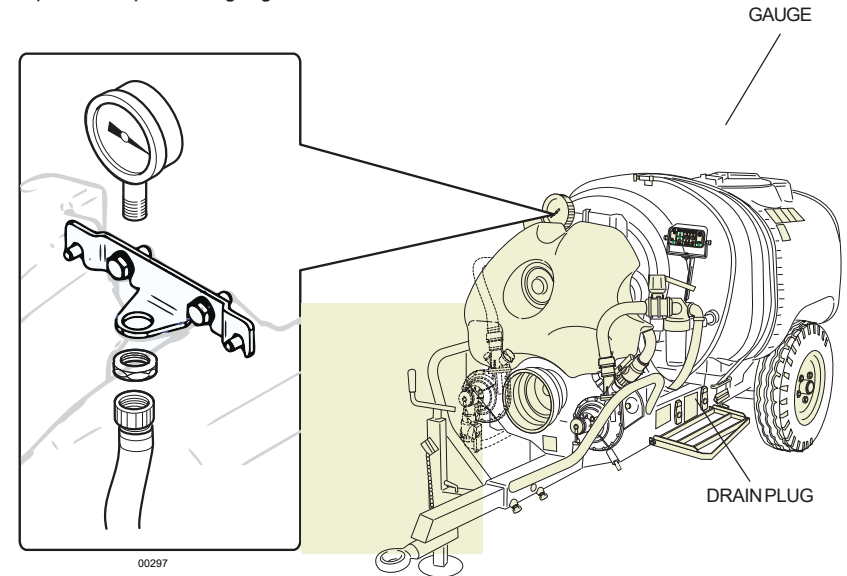

ANY OTHER INTERVENTION HAS TO BE CARRIED OUT AT A C.I.M.A. CUSTOMERS' SERVICING CENTER.

 THE OWNER AND/OR THE OPERATOR OF THE SPRAYER ARE NOT PERMITTED TO MODIFY THE STRUCTURE OR THE SPECIFIC OPERATION OF THE SPRAYER ITSELF. ANY REPAIRING INTERVENTION HAS TO BE CARRIED OUT EITHER AT THE DISTRIBUTORS' OR AT THE C.I.M.A. S.p.A. AUTHORIZED WORKSHOPS, OTHERWISE ANY KIND OF WARRANTY IMMEDIATELY CEASES AND C.I.M.A. S.p.A. IS CLEARED OF ANY CONSEQUENT AND/OR IMPLIED RESPONSIBILITY.

**15.1 - REPLACEMENT OF PUMP CONTROL BELT**

  Stop the engine and remove the key from the tractor's control panel.

1. Remove the fan assembly protection, by unscrewing the screw fastening it to the frame.
2. Completely unscrew the tightener spring adjusting screw: the pump support plate will so freely turn.
3. Remove the worn out belt, by getting it first loose from the pump pulley and then from the upper control pulley.
4. Insert the belt first into the race of the upper pulley and then into the race of the pump pulley.
5. Reinstall the spring of the belt-tensioner according to the suggested tensioning conditions.
6. Mount back the fan assembly protection casing.

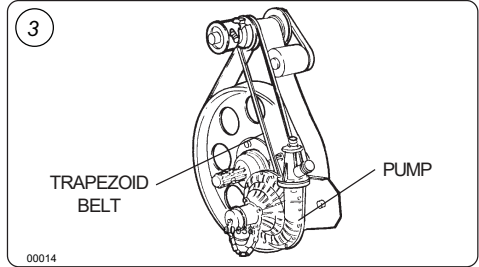
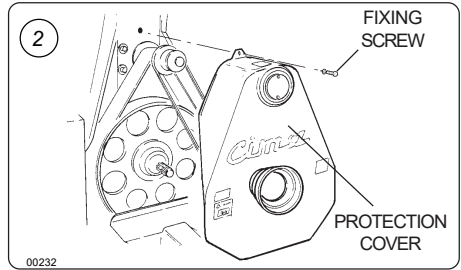
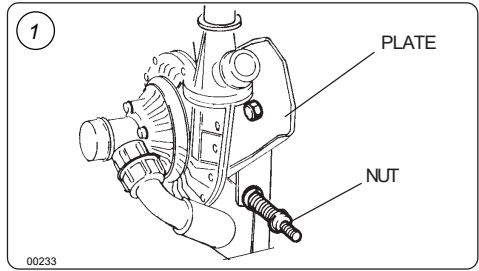

 Carefully tighten the screws that were undone during the belt replacement.

**2.1 - TERMINOLOGY**

The terms FRONT, REAR, RIGHT and LEFT utilised in this publication refer to the sprayer as seen by an operator from behind the operative unit along the drive line and facing it: **the rear part** of the machine is that closest to the operator, and is where the distribution device (Head) is mounted - and **the front part** is the one that gets attached to the tractor.

**2.2 - ABBREVIATIONS**

g	.....	grams
h	.....	hour
ha	.....	hectare
ha/h	.....	hectare per hour
l	.....	litres
l/h	.....	litres per hour
l/ha	.....	litres per hectare
kg	.....	kilogram
kg/cm <sup>2</sup>	.....	kilograms per square centimetre (atmosphere)
km	.....	kilometre
km/h	.....	kilometres per hour
Lm	.....	width in metres
m	.....	metre
Mesh	.....	N° of meshes per linear inch
Micron	.....	1/1000 of millimetre
PTO	.....	power take-off
RPM	.....	revs per minute
s	.....	seconds

**2.3 - DECALS**

The safety and use/maintenance decals applied to the machine are described in the following paragraph.

 Every decal is marked with its part number, in case it needs to be replaced.

**Safety**

- 1 - 95001 - STOP THE ENGINE AND REMOVE THE KEY FROM THE TRACTOR'S CONTROL PANEL BEFORE CARRYING OUT ALL MAINTENANCE OR REPAIR OPERATIONS
- Positioned over the servo amplifier unit protection plastic casing.

- 2 - 95004 - **DANGER OF CONTAMINATION BY CONTACT OR POISONOUS PRODUCTS INHALATION**  
- Positioned above the main tank, in the forward part, next to the filler spout.
- 3 - 95005 - **DANGER, PARTS IN MOTION. BEFORE REMOVING PROTECTION GUARDS, STOP THE TRACTOR, REMOVE THE KEY FROM THE TRACTOR'S CONTROL PANEL AND ENSURE THAT ALL MOVING PARTS HAVE STOPPED**  
- Positioned on the tank front section, behind the fan casing.
- 4 - 95008 - **THE SPRAYER ISN'T EQUIPPED WITH THE PERSONAL CLEANING ADDITIONAL TANK**  
- Visible on the hands-washing tank housing, when this isn't mounted.
- 5 - 95015 - **BEFORE UTILISING THE RELEASE DEVICE, STOP THE TRACTOR, REMOVE THE KEY FROM THE TRACTOR'S CONTROL PANEL AND ENSURE THAT THE FAN HAS STOPPED**  
- Positioned on the servo amplifier unit protection plastic casing cover.
- 6 - 95010 - **MAXIMUM OPERATING SPEED OF THE DRIVE OUTLET (PTO): 540 RPM**  
- Positioned near the drive outlet.
- 7 - 95007 - **DANGER OF SPRAYS: KEEP AT A SAFE DISTANCE**  
- Positioned on the frame rear section, on the left side.
- 8 - 95006 - **WARNING: CONSULT THE USER AND MAINTENANCE MANUAL BEFORE USING OR INTERVENING ON THE MACHINE**  
- Positioned on the left-hand side of the tank, in the forward part of this one.
- 9 - 95009 - **DANGER: GLOVES MUST BE USED TO EMPTY THE TANK**  
- Positioned on the unit's left side, near the draining cock.
- 10 - 95077 - **IT IS FORBIDDEN TO ENTER INTO THE TANK!**  
- Positioned on the tank left side, near the main filler.

## Use and maintenance

- 11 - 95055 - **CAUTION, THE UNIT ISN'T HOMOLOGATED FOR CIRCULATING ON ROAD**  
- Positioned on the tank, in the left front section.
- 12 - 95059 - **HOOKING POINT FOR THE LIFTING OF THE MACHINE, N°2**  
- One hooking point is positioned in the machine front section, while the other one is placed on the distribution devices' rear fastening bracket.
- 13 - 95079 - **CHECK THE OIL LEVEL EVERY 8 HOURS: FAN SHAFT BEARINGS**  
- Positioned on forward of the chassis, near the oil level dipstick
- 14 - 95054 - **GREASE EVERY 200 HOURS: FAN BELT-TENSIONER SUPPORT, FREE WHEEL, WHEEL HUBS, DRAWBAR ARTICULATED JOINT AND SUPPORT FOOT**  
- Positioned on the right front side frame  
- Positioned in the front section, near the Power Takeoff.  
- Positioned on the wheel  
- Positioned on the steering drawbar (for the versions on which it is foreseen).  
- Positioned on the support foot.
- 15 - 95076 - **LUBRICATE EVERY 6 MONTHS: PUMP BEARINGS**  
- Positioned on the left side of the servo amplifier unit protection plastic casing, near the pump.  
- Positioned on the right side of the servo amplifier unit protection plastic casing, near the additional agitation pump (for the models where it is foreseen).

- 2. CAUSE: the 2 drive outlets are out of alignment or are not parallel.  
**REMEDY:** Position the 2 drive outlets (PTO) correctly.
- E. FAULT: Continuous and abnormal noise level, accompanied by vibrations of fan unit.**
  - 1. CAUSE: Broken fan shaft bearings.  
**REMEDY:** Refer to the C.I.M.A. service point.
- F. FAULT: Intermittent operation of the whole distribution device**
  - 1. CAUSE: Faulty sealing of the hydraulic circuit, going from the tank's (T1) suction piping to the manual (P8) or electrical (E7) distributor.  
**REMEDY:** Carefully inspect all the points at which suction of air can take place, including as well those at which no liquid seepage is detected. Check the proper tightening of ring nuts, fittings and clamps. Check the efficiency of the sealers and the integrity of the piping. Reinstall the efficiency and replace parts that might have been found to be defective.
- G. FAULT: Intermittent spraying only on the one side of the distribution device**
  - 1. CAUSE: Faulty sealing of the hydraulic circuit going from the manual (P8) or electrical (E7) distributor to the distribution point involved.  
**REMEDY:** As per point F.1.
- H. FAULT: No spraying action delivered: totally or only on the one side of the distribution device**
  - 1. CAUSE: Manual distributor (P8) taps dirty or clogged, or pump suction piping clogged by hardened product deposits.  
**REMEDY:** Clean.
  - 1b. CAUSE: Electrical distributor (E7) taps blocked by incrustations in the closed position.  
**REMEDY:** After having lifted the lid off, turn the nut controlling the stroke of the tap.
  - 2b. CAUSE: Fuses of the electrical control panel interrupted when the electrical (E7) distributor's taps are closed.  
**REMEDY:** Replace the fuses after having manually checked the solenoid valves' operation.
  - 3b. CAUSE: Power cable W1 of the electrical panel wrongly connected with the taps of the electrical distributor (E7) in the closed position.  
**REMEDY:** Connect correctly.
  - 4. CAUSE: Defective electrical connections.  
**REMEDY:** Refer to the C.I.M.A. service point.
  - 5. CAUSE: Pump defective (only in case total delivery missing).  
**REMEDY:** Refer to the C.I.M.A. service point.
  - 6. CAUSE: Broken pump belt.  
**REMEDY:** Replace the belt (See Paragraph 15.1).



**THE CAUSES AND REMEDIES FOR THE FAULTS CONCERNING THE DELIVERY OF THE SPRAYING BY ONE OR MORE DIFFUSERS ARE INDICATED IN THE USE AND MAINTENANCE MANUAL OF EACH SPRAYHEAD.**

**A. FAULT: By utilising the filler piping the pump doesn't operate (suction)**



It is necessary to disengage the drive outlet (PTO) and wait for it to stop rotating before repeating the filling operation.

- 1. CAUSE: the quantity of water poured into the tank is insufficient to trigger the pump.  
**REMEDY:** Add water to the tank until the pump starts its cycle.
- 2. CAUSE: the filler piping sucks in air.  
**REMEDY:** Completely submerge the suction filter of the filler piping.
- 3. CAUSE: Hydraulic circuit not sealing properly.  
**REMEDY:** Check the tightening of ring nuts, fittings and clamps. Check the efficiency of sealers and that piping elements are not cracked or broken. Replace parts that are possibly found to be defective.
- 4. CAUSE: Slipping of the pump's belt.  
**REMEDY:** Check the tension of the belt-tensioner's spring.
- 5. CAUSE: The pump's belt might be broken.  
**REMEDY:** Replace the belt.
- 6. CAUSE Defective pump.  
**REMEDY:** Contact the C.I.M.A. Customers' service.

**B. FAULT: Leakage and dripping from the pump**

- 1. CAUSE: Non-sealing of the fittings and clamps connecting the piping to the pump.  
**REMEDY:** Check for proper tightening of ring nuts and clamps. Check the efficiency of the sealers. Replace parts that are possibly found to be defective.
- 2. CAUSE: The sealers (O.Rings) of the external coupling flanges don't seal the pump properly.  
**REMEDY:** Refer to the C.I.M.A. service point.
- 3. CAUSE: Mechanical sealing defective.  
**REMEDY:** Refer to the C.I.M.A. service point.

**C. FAULT: Drop in pressure of the hydraulic circuit signalled by the gauge**

- 1. CAUSE: Dirty filter.  
**REMEDY:** Clean the cartridge
- 2. CAUSE: Faulty sealing of the hydraulic circuit.  
**REMEDY:** Check the operation of the pump and its belt. Check the proper tightening of ring nuts, fittings and clamps. Check the efficiency of the sealers and the integrity of the piping. Replace the parts that are possibly found to be defective.
- 3. CAUSE: Centrifugal pump defective. See "B".  
**REMEDY:** As per point "B".
- 4. CAUSE: Gauge defective.  
**REMEDY:** Replace the pressure gauge.

**D. FAULT: Vibration of fan unit**

- 1. CAUSE: Fan dirty.  
**REMEDY:** Clean. (It is advisable to refer to the C.I.M.A. service point).

**16 - 95057 - HAND WASHING TANK TAP**

- Positioned on the left-hand side of the tank, next to the tap.

**17 - 95065 - WARNING: NEVER OPERATE THE SPRAYER WITHOUT LIQUID IN THE TANK**

- Positioned on the tank, in the left section.

**18 - 95069 - INDICATIONS FOR THE USE AND MAINTENANCE OF THE SOLENOID VALVES**

- Positioned on the frame, on the right rear side (for the versions on which it is foreseen).

**19 - 95060 - INDICATION OF THE WHEELS OPERATING PRESSURE**

**95056** - Positioned on the frame, on the left rear side.

**20 - 95075 - INDICATION ON THE OPERATION OF THE 3-WAY TAP (P3)**

- Positioned on the frame on the left side, near the pump (P4).

**21 - 95078 - INDICATION ON THE OPERATION OF THE 3-WAY TAP (P11)**

- Positioned on the right side, near the additional pump (P10) (for the versions on which it is foreseen).

Positioning of the safety, use and maintenance decals

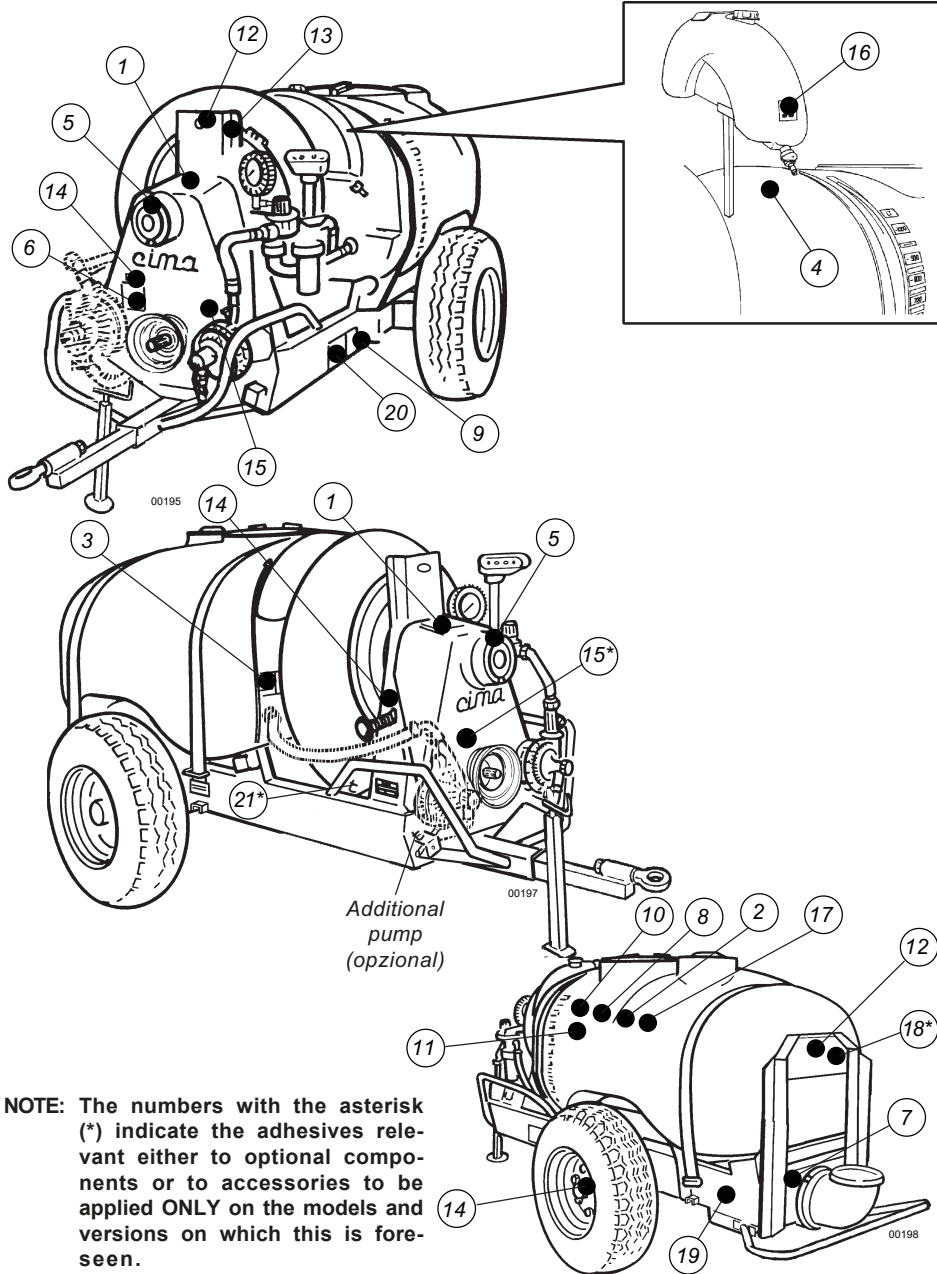

13.9 - TABLE OF MAINTENANCE OPERATIONS

CHECK	SEASON START TREATMENTS	BEFORE EVERY TREATMENT	END OF EVERY TREATMENT	SEASON-END TREATMENTS	INTERVAL
Fan belt-tensioner spring: CHECK LENGTH 9-12cm.	YES	YES	**	**	**
Pump belt-tensioner spring: CHECK LENGTH 4-5cm.	YES	YES	**	**	**
Fan shaft support: CHECK OIL LEVEL	YES	YES	**	**	8 hours
Fan shaft support: REPLACE OIL LEVEL	**	**	**	YES	Yearly
Fan belt-tensioner support: GREASING	**	**	**	YES	200 hours
Free wheel: GREASING	**	**	**	YES	200 hours
Pump bearing: OILING	**	**	**	YES	6 months
Wheels bearings: GREASING	**	**	**	YES	200 hours
Support foot: GREASING	YES	**	**	YES	200 hours
Steering drawbar (For versions in which this is envisaged): GREASING (3 points)	**	**	**	YES	200 hours
Filter: CHECK CLEANING	**	**	YES	YES	**
Fittings and fittings: CHECK GOOD CONDITION	YES	YES	**	YES	**
Clamps and fittings: CHECK PROPER TIGHTENING	YES	YES	**	YES	**
Pressure gauge drain plug: UNSCREW AND CLEAN	**	**	YES	YES	**
Drawbar: CHECK THE SCREWS AND FIXING BOLT TIGHTENING	YES	YES	**	YES	**
Wheels: CHECK THE NUT TIGHTENING AND CHECK TYRE PRESSURE	YES	YES	**	YES	**
Axle and wheels hubs: CHECK THE BOLT TIGHTENING	YES	YES	**	YES	**
Sprayer: EXTERIOR WASHING	**	**	YES	YES	**
Hydraulic circuit and tank: COMPLETELY DRAIN AND WASH	**	**	YES	YES	**
Sprayer: STORAGE	**	**	**	YES	**

### 13.7 - PUMP BELT TENSIONER

Check length "L" of the spring (refer to picture): it should be in tension between **4 and 5** cm.

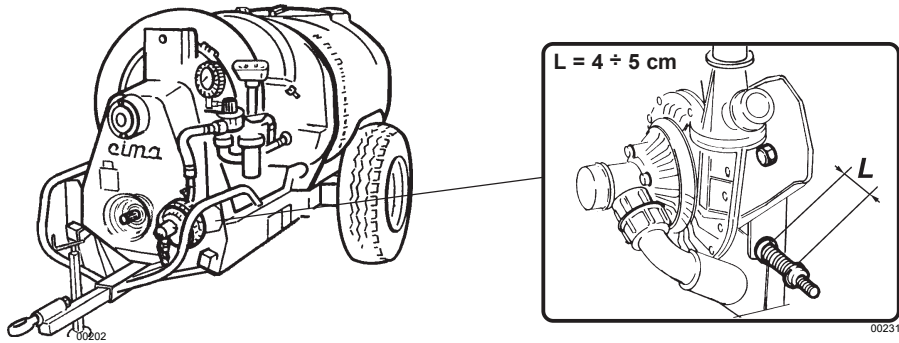

### 13.8 - TANK REMOVAL OR REPLACEMENT



This operation has to be carried out by a C.I.M.A. service point



The operation has to be carried out by complete absence of liquid residuals both inside the tank and in the hydraulic circuit

1. Make the tank free from all the hydraulic and pneumatic connections.
2. Loosen the screw nut (4), for tensioning the tank fastening belt.
3. Remove the split pin (3).
4. Unscrew the belt end (2), in order to make the tank free; carry out the same operation for the second belt (1).
5. Lift the tank and remove it from the frame.
6. Either replace or reposition the tank.
8. Position again the belts in the relevant seats.
9. Screw on every belt the adjusting screw nut, in order to get the belts themselves tensioned and to firmly fasten the tank to the frame.
10. Mount back both the safety split pins.

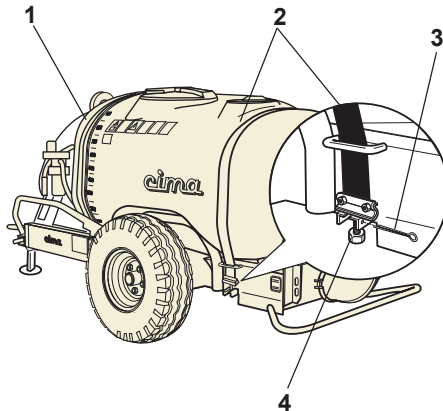

Check the tank fastening belt tension before each treatments.

### \* Safety decals

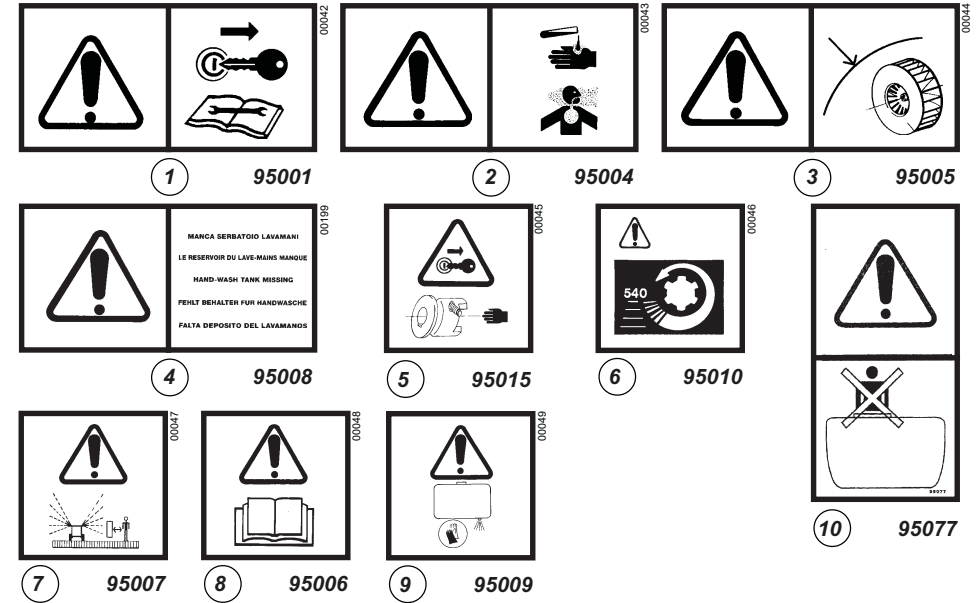

### \* Use and maintenance decals

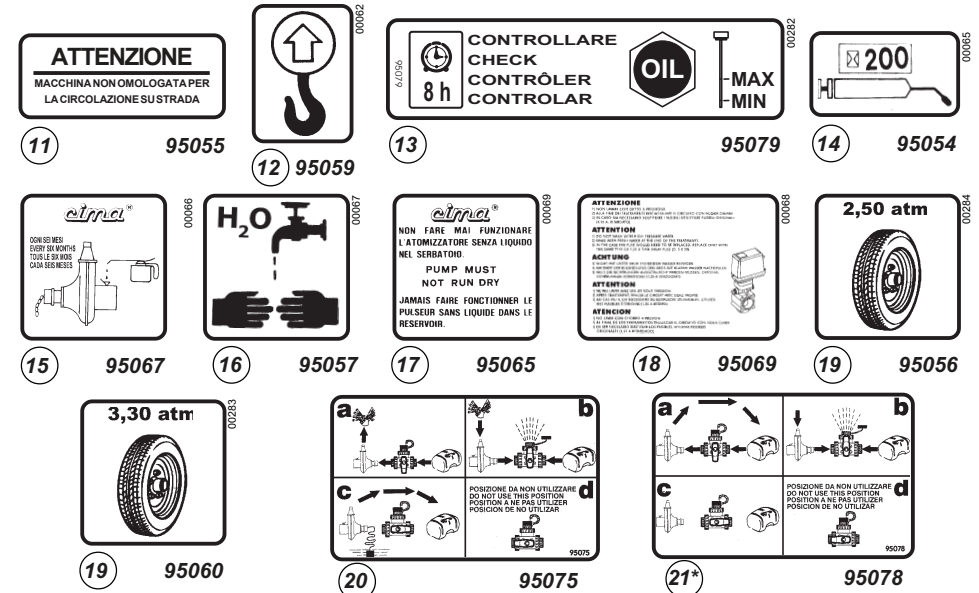

### 3.1 - MACHINE IDENTIFICATION



00070 Identification nameplate

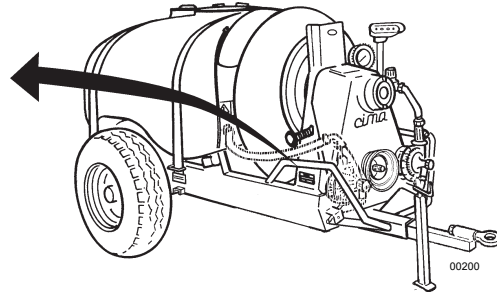

### 3.2 - TECHNICAL ASSISTANCE

C.I.M.A. S.p.A. is at the complete disposal of customers for any type of intervention. The names and addresses of its service network, both in Italy and in foreign countries, can be requested from:

**C.I.M.A. S.p.A. - 27040 Montù Beccaria - Loc. Molino Quaroni (PV) - ITALIA**  
 tel. 0385-246636 - fax 0385-246637  
 from abroad tel. +39-0385-246636 - fax +39-0385-246637  
 e.mail [tecnic@cimaitalia.com](mailto:tecnic@cimaitalia.com)

### 3.3 - SAFETY NOTICES

All the preparation, use, maintenance, moving and transporting operations must be carried out only after having acquired a perfect knowledge of the regulations contained in this publication and the ability to appropriately interpret the symbols of the decals applied to the machine.



**IT IS FORBIDDEN TO UTILISE THE SPRAYER FOR PURPOSES OTHER THAN FOR ITS INTENDED USE, SINCE IT WAS MANUFACTURED ONLY FOR SPRAYING AGRICULTURAL CROPS WITH ANTI-PARASITIC PRODUCTS.**

It is necessary to scrupulously abide by the following general norms:

- always stop the tractor's engine before carrying out any operation on the sprayer;
- check that the weight and power of the tractor are compatible with the sprayer to be used;
- before utilisation, check the correct tightening and securing of the machine's various components, paying particular attention to the safety protections and to the moving parts;
- only utilise protected cardan shafts provided with CE conformity certification.  
 Carry out the assembly only if the drive outlets of both tractor and sprayer are equipped with the protection counter-guard;
- check that the cardan shaft is blocked by the appropriate anti-rotation chains;
- keep people and animals away from the machine before starting it up;

7. Clean the impeller, by avoiding to use high pressure water jets: they can cause infiltrations into the fan shaft support and consequently damage the bearings.
8. Mount back the casing (2), by paying a particular attention to get it perfectly coupled with the rear cover.
9. Fasten the fan casing, with the collar (5), to the rear cover and with the collar (1) to the union elbow.
10. Mount back the distribution device (head).
11. Mount back the hands-washing tank (only for BLITZ 45 and 50 versions).



Carefully tighten all the fastening collars' bolts.

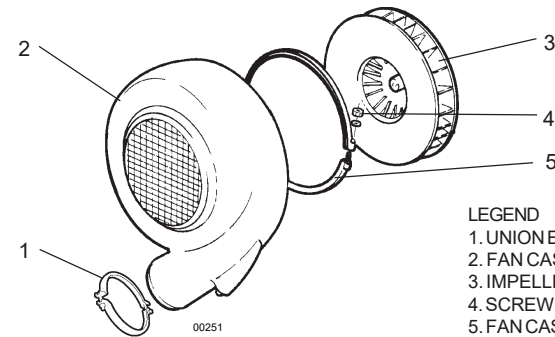

- LEGEND
1. UNION ELBOW FASTENING COLLAR
  2. FAN CASING
  3. IMPELLER
  4. SCREWNUT
  5. FAN CASING FASTENING COLLAR

### 13.6 - FAN BELT TENSIONER

Check length "L" of the spring (refer to Picture): it should be in tension between **9** and **12** cm.

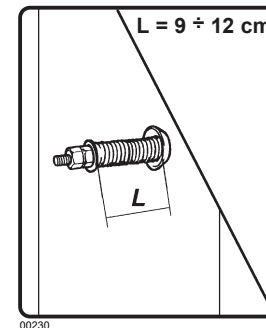

00230

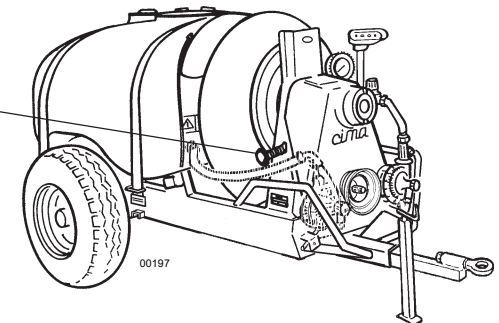

00197



### 13.3 - FAN SHAFT SUPPORT OIL REPLACEMENT



Let the fan support oil replacement intervention be carried out at a C.I.M.A. customers' service centre.

1. Unscrew and remove the oil filling plug with the dipstick.
2. Remove the oil drain plug and let the oil completely flow out from the fan shaft support.
3. Check the oil drain plug and the relevant seal for integrity, replace them, if necessary, and close again the oil drain plug.
4. Through the filling pipe, pour a SAE 90 oil proper quantity, up to reach the MAX notch on the dipstick:
  - about 0,10 kg for the 45 model
  - about 0,18 kg for the 50 model.
5. Position again the plug with the dipstick and close the oil filling pipe.

### 13.4 - CLEANING OF FILTER'S CARTRIDGE

1. Set the lever of 3-way tap (P3) to the "c" position.
2. Completely close the pressure regulator (P5), by turning the handle clockwise.
3. Close the manual distributor's taps (P8), or electrical (E7).
4. Undo the thumb screw and remove the body of the filter.
5. Extract the cartridge: clean the grill and the retaining "O" Ring.
6. Reassemble the cartridge and secure the lid with the thumb screw. Pay attention to the assembling of the lid's "O" Ring as the incorrect sealing of the filter will jeopardise the proper operation of the sprayer and cause loss of the mixture.

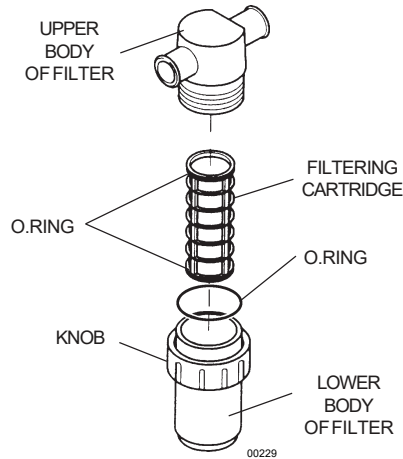

### 13.5 - CLEANING OF THE FAN



It is advisable for the cleaning of the fan to be carried out at a C.I.M.A. service point. Dirt accumulation or incrustations can unbalance the fan, inducing vibrations that could cause breakage

1. Remove the hands-washing tank (only for BLITZ 45 and 50 versions).
2. Remove the distribution device (head).
3. Remove the fastening collar (1), fixing the fan casing outlet orifice to the union elbow.
4. Remove the two collar (5) fastening bolts, fixing the fan casing to the rear cover.
5. Remove the collar (5), locking the fan casing to the rear cover.
6. Extract the fan casing (2).



The impeller hasn't to be disassembled.

- don't wear articles of clothing that might get caught in moving parts;
- keep to a low speed while negotiating bumps or crossing ditches.



- All maintenance and repair operations must be carried out only after having rinsed the tank and flushed the system.
- Before operating within the tank it is necessary to wash it thoroughly with clean water.
- It is forbidden to perform welding operations if ammonium salts were previously used.
- It is forbidden to use the machine within a potentially explosive environment.
- The application of paints and/or solvents, the washing of closed environments and machinery as well as the utilisation of the air flow for purposes other than those expressly concerning the spraying of agro-chemicals is not permitted.
- It is forbidden to enter the tank.

### 3.4 - SAFETY SYSTEMS

All machine moving parts are suitably protected by guards and highlighted through the use of warning decals.



- It is forbidden to use the machine with these guards removed.
- Before removing the protection, stop the tractor's engine and remove the key from the control panel.

The pictures illustrate the machine's guarded parts:

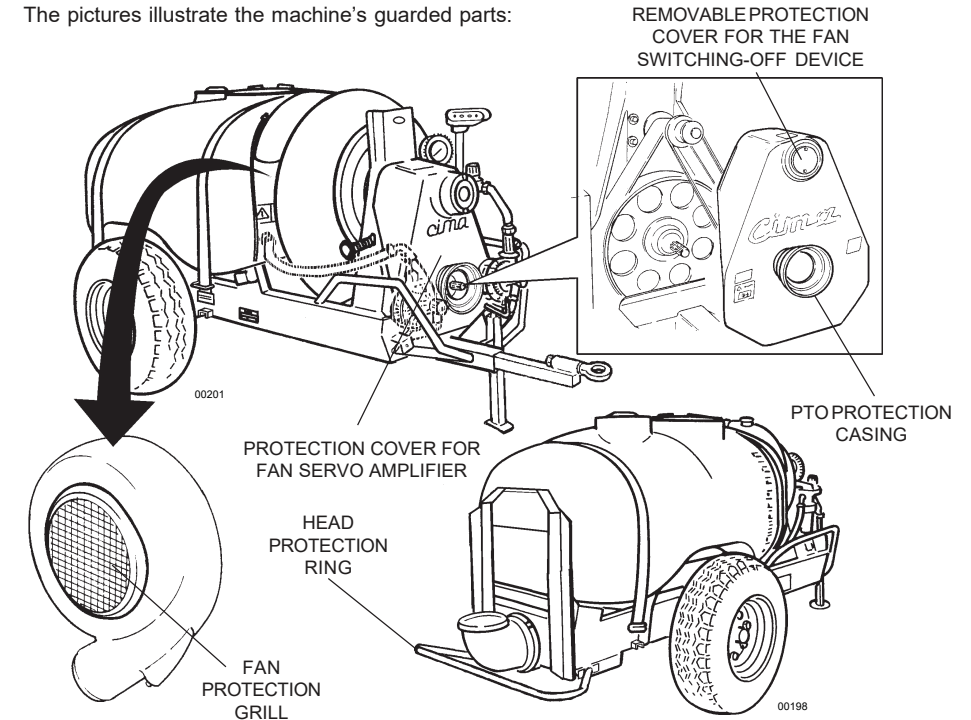



THE OWNER AND/OR THE OPERATOR OF THE SPRAYER ARE NOT PERMITTED TO MODIFY THE STRUCTURE OR THE SPECIFIC OPERATION OF THE SPRAYER ITSELF. ANY REPAIRING INTERVENTION HAS TO BE CARRIED OUT EITHER AT THE DISTRIBUTORS' OR AT THE C.I.M.A. S.p.A. AUTHORIZED WORKSHOPS, OTHERWISE ANY KIND OF WARRANTY IMMEDIATELY CEASES AND C.I.M.A. S.p.A. IS CLEARED OF ANY CONSEQUENT AND/OR IMPLIED RESPONSIBILITY.

### 3.5 - HANDLING OF AGRO-CHEMICALS

The **operator** could become contaminated due to accidental spray, contact or inhalation of products or crop-spraying mixtures.

The **environment** could become polluted by mixture over-spills, puncturing of containers, uncontrolled storage of used and unwashed containers or spillage into waterworks.

In order to avoid these risks the preparation and filling operations must be carried out in suitably appointed and adequately equipped sites.

#### 3.5.1 - Storage

**Fixed / stationary:** the site used must be well ventilated and secured by lockable doors in order to prevent even accidental access by children or unauthorised persons.

**Mobile:** the carrier equipment must be properly locked and kept under conditions whereby access by children or unauthorised persons can be prevented during the absence of the operator. All full or partially utilised containers must be secured against tipping, falling or breakage during transportation.

Both types of storage must:

- have a suitable container for the storing of empty packaging materials should a specific storage area not be available;
- have a clean water supply readily available for washing, by means of a specific container or through connection to the waterworks system;
- have the use of fire extinguishers, should flammable products and substances be stored.



- All packages, whether whole or partially utilised, must be stored in their original packing and with the warning instructions clearly displayed and legible.
- The storage indications must always be scrupulously adhered to, as well as their utilisation and possible disposal as suggested on the product's original packaging.

#### 3.5.2 - Specific equipment

The site at which the preparation and filling out will take place must provide for:

- all the equipment necessary to the precise measuring of both the water quantity and the dose of product to be mixed in the tank at every filling;
- all the equipment and means useful to the preparation of the mixture and for the cleaning of the operator in case of contamination;
- all tools necessary to facilitate the direct introduction of the agro-chemicals in the tank;
- the allocation of clothing and specific equipment in order to avoid contamination by contact or inhalation during the whole operative phase of the intervention;
- the availability of proper equipment able to stop the uncontrolled spilling and flowing of the mixture;
- a retaining valve on the feed pipe when the filling of the tank takes place directly from the waterworks system.

STEERING DRAWBAR (\*)  
(3 lubrication points)

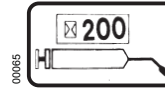

(\*) For versions in which this is envisaged

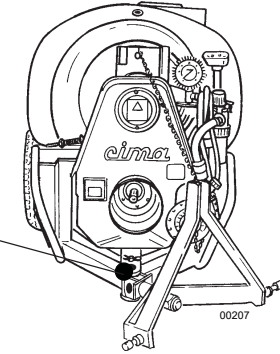

### 13.2 - FAN SHAFT SUPPORT OIL LEVEL CHECK

1. Unscrew and remove the oil filling plug with the dipstick.
2. Clean the dipstick and introduce it again.
3. Extract the dipstick and check the oil level, which has to be between the two minimum and maximum level notches of the dipstick itself.  
Should it be necessary to top up the level, add some SAE 90 oil, up to reach the dipstick upper notch (MAX).
4. Introduce and screw the oil filling plug with the dipstick.

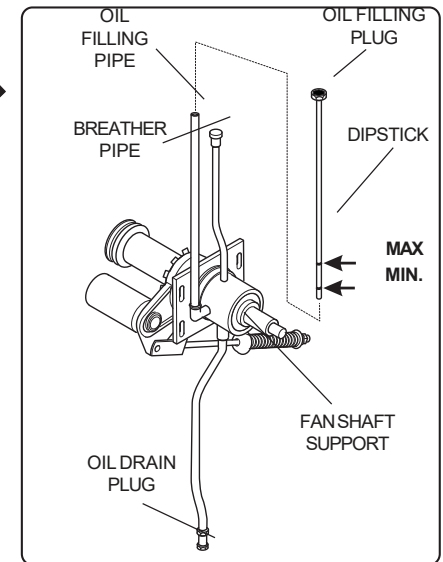
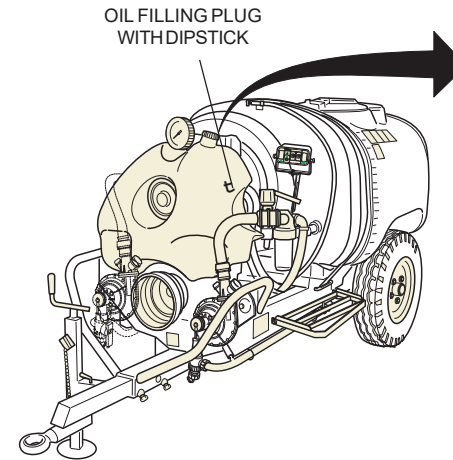



ALL OPERATIONS MUST BE CARRIED OUT WITH THE ENGINE SWITCHED OFF AND WITH THE IGNITION KEY REMOVED FROM THE CONTROL PANEL.

### 13.1 - LUBRICATION

Maintenance point	Action	Consumption material	Periodicity
Fan shaft bearings support	Check oil	Oil SAE 90	8 hours
Fan belt-tensioner support	Greasing	Grease Type EP Classe NLGI 2	200 hours
Pump bearings	Oiling	Engine oil	6 months
Free wheel	Greasing	Grease Type EP Classe NLGI 2	200 hours
Wheel hubs	Greasing	Grease Type EP Classe NLGI 2	200 hours
Support Foot	Greasing	Grease Type EP Classe NLGI 2	200 hours
Steering drawbar	Greasing	Grease Type EP Classe NLGI 2	200 hours
Fan shaft bearings support	Change oil	Oil SAE 90	Yearly



Carefully clean the greasing nipples and the oil filler in order to avoid that, during lubrication, dirt might be introduced.

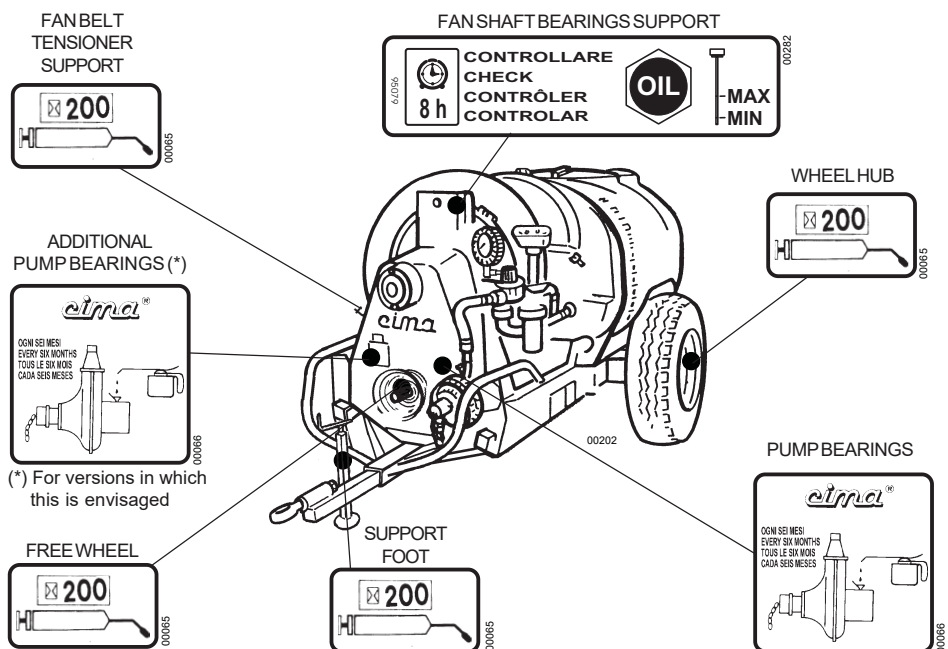

### 3.5.3 - Disposal of empty containers and agro-chemicals residues

Agro-chemicals are classified as "special" waste and their disposal must take place separately from "urban" wastes.



Empty packaging and contaminated containers to be done away with cannot be dispersed, burned or buried.

The washing water for the cisterns and the tools utilised for the preparation of mixtures cannot be emptied on the ground, spilled into the sewage system or in waterways and rivers.

The disposal of special wastes is regulated by specific norms. In order to perform this operation it is necessary to obtain the relevant information from the Local Offices specifically appointed to rule on this subject. The non compliance with these regulations can cause considerable damage to persons and animals as well as polluting the environment.

### 3.5.4 - Personal means of protection

The toxicity of agro-chemicals forces persons working with them to wear adequate protective clothing and accessories in order to avoid risks of contamination by contact or inhalation.

In each of the following work stages:

- filling of tanks and adding of the agro-chemical,
- dusting and spraying,
- adjusting of the sprayer,
- emptying and cleaning of the tank,
- replacement of the agro-chemical,
- maintenance interventions,

it is necessary to wear personal protection clothing and accessories.

The following must be worn:

- Polyethylene or polyvinyl gloves.
- Full, waterproof cotton overalls, in order to guarantee transpiration, fitted with polypropylene side flaps.
- In commerce, one-time 'tyvek' overalls are available which, after use (see picture), must be disposed of according to the modalities applicable to toxic waste.
- A protective half-mask in polychloroprene rubber with 1 or 2 filters. Filters for gases and organic fumes, of European A1-class vapours, are envisaged and these can be combined with anti-dust models of P1 European class, for harmful mists and powders, or P2, for harmful and toxic mists and powders.

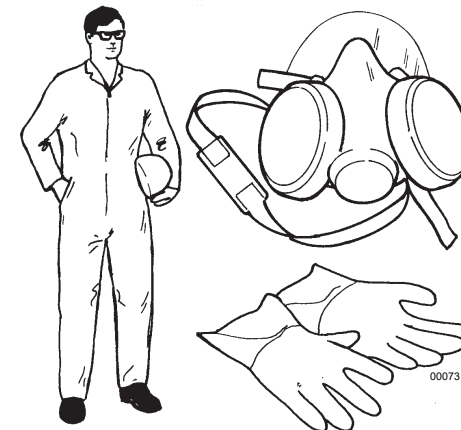

The filters must be replaced:

- when the smell/taste of agro-chemicals can be detected, and that of active A1-class carbons;
- when difficulty in breathing is experienced for the anti-dust filters of class P1 and P2. In any case it is necessary to make use of all personal means of protection as suggested by the manufacturers.

The pictures indicate the position of the main components of the sprayer.

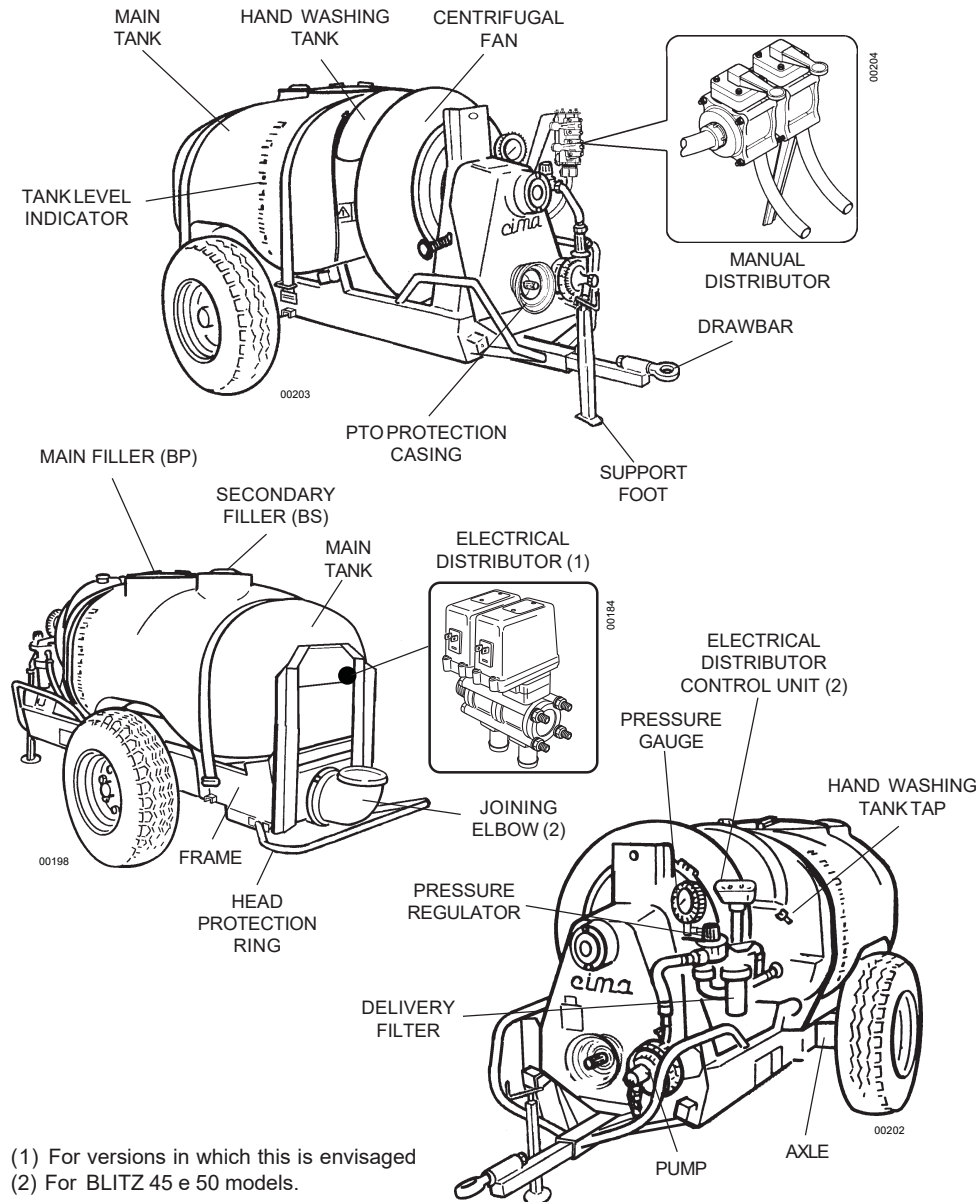

 NO TRAILER-MOUNTED SPRAYER IS HOMOLOGATED FOR CIRCULATING ON ROAD THE FOLLOWING ACTIONS ARE NOT ALLOWED:

- Transporting or lifting the sprayer with residual quantities of mixture in the tank for purposes differing from its destined usage.
- The transporting of people, animals or things.
- The trailing of vehicles or equipment.

 Road transport must take place in the complete observance of road regulations in force in the Country where the machine is used. The operator is responsible for possible defaults due to the non observance of said regulations.

• Lifting and transport of the sprayer

 Before carrying out any operation it is essential to verify that no mixture residues are left in the tank.

1. Check that the cables or chains used for the lifting are adequate for the weight to be lifted (machine – distribution devices - accessories).
2. Hook the machine through the specific support point indicated by the specific decal on the frame, checking all the parts involved in the operation.
3. Lift the machine, verifying that it is properly balanced.

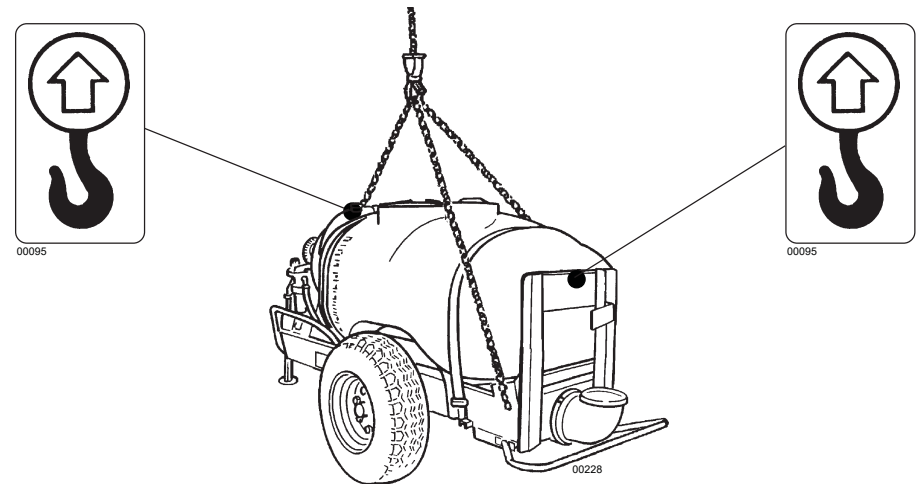

4. Position the sprayer on the transporting vehicle in perfectly stable conditions.
5. During transport the machine must be immobilised and fastened to the carrier by way of suitable strapping.

- d. Clean out the filter cartridge.
- e. Keep the machine in a ventilated place, sheltered from rain or sun: sunrays are the worst enemies of plastic and rubber parts.

### 11.4.2 - End of seasonal cycle

- **The operator must:**
  - a. Take the utmost care in carrying out the operations envisaged at the end of the daily treatments: the cleaning of the hydraulic circuit must be done at least twice. Check that no product residues are left in any part of the circuit.
  - b. Lubricate all the greasing points, replace the fan support oil, then let the atomizer operate for some minutes.



**THE PUMP HAS NEVER TO DRY-OPERATE.**

- c. Completely drain the hydraulic circuit, paying a special attention to the centrifugal pump; in order to completely drain the pump, remove the draining plug, which is mounted on the pump itself.

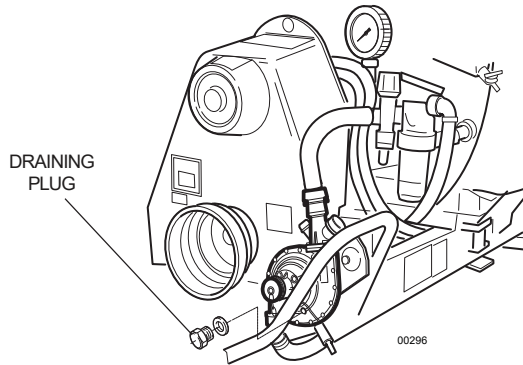

**Avoid using anti-freeze solutions.**

- d. Check the proper operation of all parts and of the machine structure. In case of faults being detected, request the intervention of one of our service points.
- e. Keep the machine in a well ventilated place, sheltered from rain, icing and direct sun rays.



**The use of detergent products for the cleaning operations is allowed only in the observance of the regulations in force. For these, the operator must gather the relevant information from the specifically appointed bodies ruling on this subject.**

### 4.1 FRAME WITH DRAWBAR

**DRAWBAR WITH STANDARD TRAIL EYE.** It is inserted in the frame front section; its position is regulated by means of the insertion of a through screw, provided with a self-locking screw nut. The drawbar is locked by means of the two lateral screws, foreseen for this purpose

- Adjustable in **height** for 13 cm (16 cm for the 1500-2000 litres BLITZ 55 models).
- Adjustable in **length**, with displacements of 8 – 16 – 24 cm.



**After every regulation, carefully tighten the screws and the bolts involved in the operation carried out.**

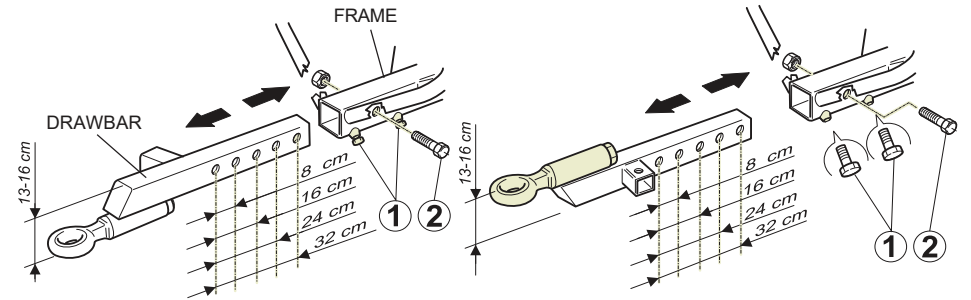

**BRACKET DRAWBAR (for the versions on which it is foreseen).** Like the drawbar with standard trail eye, also this one is inserted in the frame front section; its position is regulated by means of the insertion of a through screw, provided with a self-locking screw nut. The drawbar is locked by means of the two lateral screws, foreseen for this purpose.

- Adjustable in **height** for 13 cm (16 cm for the 1500-2000 litres BLITZ 55 models).
- Adjustable in **length**, with displacements of 8 and 16 cm.



**After every regulation, carefully tighten the screws and the bolts involved in the operation carried out.**

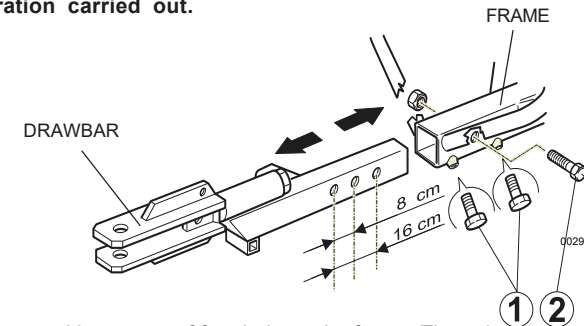

**AXLE.** It is fastened by means of four bolts to the frame. The axle can be mounted in three different positions, so modifying the wheel base between the wheels and the drawbar. The wheels' axle shafts, inserted in the frame axle and locked there by some especially foreseen screws, allow to regulate the **track width**, by adapting it to the intervention requirements.

- The height with respect to the ground can be regulated. (The misalignment between the axle shaft and the wheels' hub allows a variation of 12 cm). It is enough to turn the axle shafts.

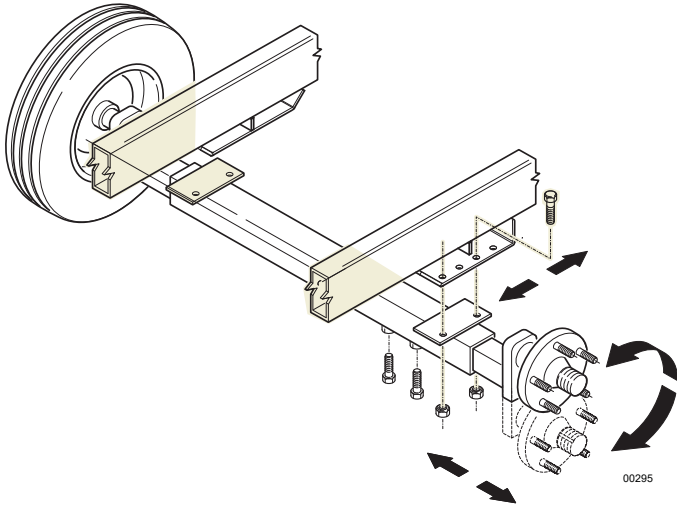

**After every regulation, carefully tighten all the screws and the bolts concerned by the intervention.**

**WHEELS.** The wheels' hubs are equipped with grease nipples for the bearings lubrication (see 14.1). The tyres' size and the operating pressure are indicated at step 4.5.2.

**SUPPORT FOOT** with crank regulation. It assures the machine stability, when this last one isn't hitched to the tractor.



**ALWAYS use the adjustable support foot, in order to stabilize the sprayer when it isn't hitched to the tractor.**

The support foot can be fastened to the sprayer in three different positions, according with the different operative requirements:

- Position A** - applied to the drawbar, it assures the necessary stability to the sprayer, when it isn't hitched to the tractor.
- Position B** - vertically applied to the frame, it allows to regulate the length and to modify the drawbar height, before this one is hitched to the tractor.
- Position C** - horizontally applied to the frame, after that the sprayer was hitched to the tractor, it allows to use the sprayer itself (**treatment position**).

## 11.3 - THE TREATMENT



**IT IS ADVISABLE TO BEGIN TREATMENT AT THE HEADLANDS..**

- **The operator must:**
  - shake the mixture in the tank before starting the treatment, re-circulating it completely for as long as it takes to make it homogeneous.
  - continue to shake the mixture until the treatment is resumed should the intervention momentarily be interrupted. If the utilisation is to be deferred, check that the filter cartridge is clean before resuming and **agitate the mixture** that has remained in the tank.
  - ensure that the hand wash supplementary tank is filled with clean water after each filling operation.
  - make use of individual protections identical to those envisaged for the preparation of mixtures if the tractor is not equipped with a pressurised cabin with aeration filters.
  - wash immediately all the elements that might have become contaminated during the treatment, promptly remove the polluted garments and **interrupt the work if these cannot be immediately replaced.**
  - keep to the preliminary operations already indicated (11.1.c), in case of wind conditions prevailing.
  - stop the engine, remove the key from the tractor's control panel.
  - pay particular attention to the treatment when close to boundaries and in proximity of dwellings, waterways, roads or public-usage paths.

## 11.4 - END OF TREATMENT - STORAGE

### 11.4.1 - Daily

- **The operator must:**
  - Wash the machine's exterior before cleaning out the hydraulic circuit. The operative sequence will permit the elimination of possible water residues from the fan casing and piping conveying the air flow to the heads.



**The washing of the sprayer's exterior must be carried out in an area in which foul waters are collected in a disposal pit. DO NOT UTILISE HIGH-PRESSURE HYDRO-CLEANERS.**

- Carry out the cleaning of the hydraulic circuit by washing the inner side of the tank with a clean water jet, then spraying it on the crop on which the treatment has just been completed: if necessary repeat this operation.
- Check the efficiency of the distribution device (head) and the cleaning of the pulverising points (diffusers), possibly replacing them if found to be damaged.

**- TENSION OF MAIN TANK FIXING BELTS;  
- ROADWHEEL PRESSURE.**

- The operator must:
  - a. Wear adequate protective clothing and accessories such as overalls, waterproof suits, gloves, glasses and masks to shield him from contamination by inhalation or contact with the products handled.
  - b. With the parameters defined during the preliminary operations, carry out the adjustments of the sprayer.
  - c. Prepare the mixtures in a well ventilated area. When in the open, the presence of wind increases the danger of contamination.
  - d. Precisely weigh the previously calculated doses of products to be mixed at every filling operation.
  - e. Avoid handling products close to open flames, embers, incandescent bodies or in the presence of flammable substances.
  - f. In order to obtain the correct volume dosage of agro-chemicals and fertiliser mixtures, the fertiliser must be first diluted.
  - g. Wash and rinse the just emptied product containers with clean water – collect the washing water and pour it in the tank before carrying out the filling – place the empty packaging in the specific container or in the collection area.
  - h. Wash the equipment and tools utilised in the preparation and place them in the chemical products storage area.
  - i. **Always** leave the area assigned to the loading and preparation of the mixtures in such condition as to avoid **any** possibility of contamination to persons or animals or of pollution to the environment.
  - l. Having completed the filling of the machine, suitably fill the tank used for personal cleansing with clean water.
  - m. If necessary, mark the field or the area of machine passes in order to provide a guide for the treatment and avoid missing or double-treating coverage areas.



**• AT THE END OF THE OPERATIONS NECESSARY FOR CARRYING OUT THE INTERVENTION, THE LOCATION-STORAGE AREAS MUST BE LEFT IN THE CONDITION REQUIRED FOR THE CARRYING OUT OF THEIR PREVENTION AND PROTECTION FUNCTIONS.**

**• BEFORE STARTING THE TRACTOR, KEEP AWAY PERSONS OR ANIMALS AND NEVER LEAVE IT UNATTENDED DURING THE PREPARATION OPERATION.**

The figure shows the support foot three possible positions

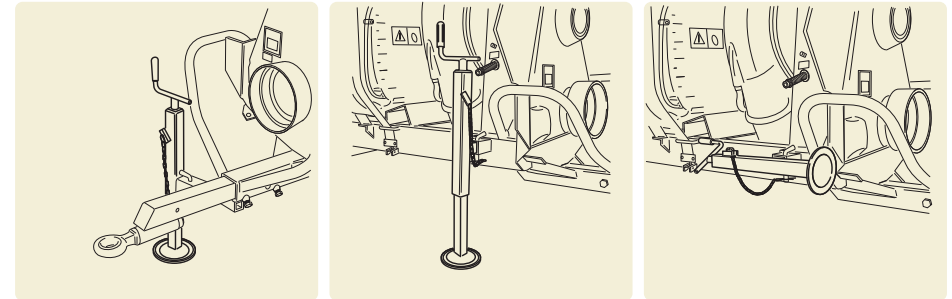

Position A

Position B

Position C

00250



**During the sprayer operation, the support foot has ALWAYS to be positioned on "C"**

**HEAD PROTECTION RING.** It is applied behind the machine, in order to protect the distribution devices (heads). It has to be mounted in the most efficacious position, according with the working conditions and with the kind of head.

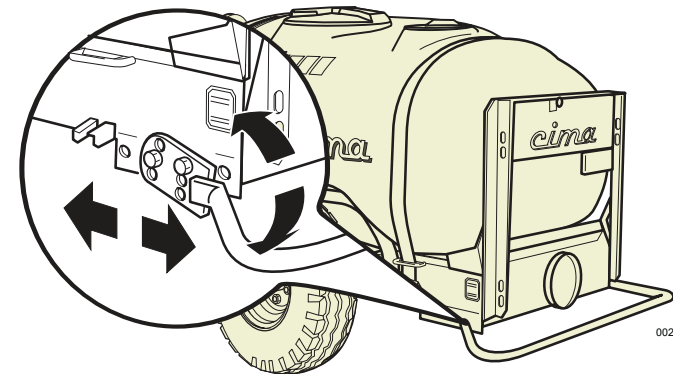

00253

**SUPPORT BRACKET** mounted on the drawbar, in order to house the transmission shaft when the machine isn't hitched to the tractor.



When the transmission shaft is mounted on the 2 power takeoffs, the bracket has always to be lowered.

**THE RESPONSIBILITY FOR THE REGULATION, ASSEMBLY AND DISASSEMBLY OPERATIONS OF THE WHEELS IS CHARGED TO THE OPERATOR, WHO HAS TO PREPARE AND TO ASSURE THE NECESSARY CONDITIONS FOR A COMPLETE SAFETY AGAINST ANY POSSIBLE ACCIDENT.**

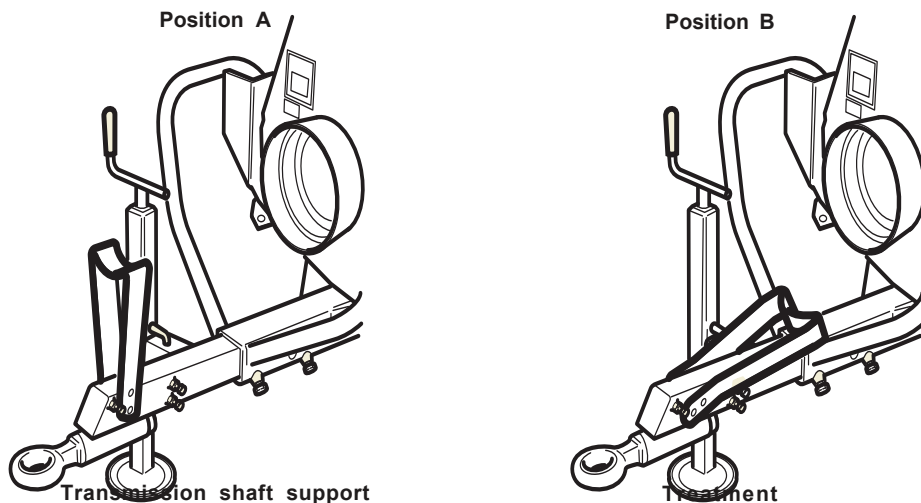

00252

## 4.2 FRAME WITH STEERING DRAWBAR (UPON REQUEST)

**A HOMOCYNETIC CARDAN SHAFT HAS TO BE USED ON THE MACHINE SIDE.**

The steering drawbar is mounted instead of the drawbar with standard trail eye. It is fastened to the frame by means of a through screw, provided with a self-locking screw nut and locked there by means of the two lateral screws especially foreseen for this purpose.

It shows a coupling triangle with 2 clip pins and the pin of the third point predisposed for hydraulic hoisters of the classes "1" and "2".

\* Class "1" : clip pins having a 22mm diameter – third point pin having a 19mm diameter

\* Class "2" : clip pins having a 28,5 mm diameter - third point pin having a 25mm diameter.

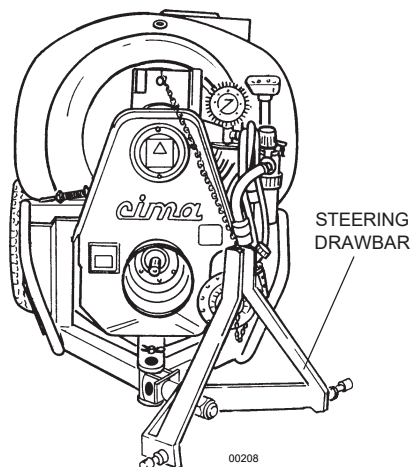

00208

## 11.1 - PRELIMINARY OPERATIONS TO TREATMENT

- The operator must:
  - a. Ascertain that the condition of the crops, the progress of the disease or the need for its prevention actually justify the treatment to be applied.
  - b. Be aware of the meteorological conditions forecast for all the time necessary for carrying out the treatment.
  - c. If possible, avoid carrying out the spraying in strong wind conditions or when one detects that the sprayed mixture disperses away from the target crop (drifting). It is advisable to suspend the treatment when the wind speed exceeds 3 m/s (10 km/hour). Should it be imperative to operate anyway, the following suggestions are made:
    - reduce the distance of the target from the spraying points, even if detrimental to the quality of the spraying
    - increase the dimension of the droplets, suitably adjusting the machine.
  - d. Check that multiple-product mixtures be physically, chemically and biologically compatible amongst themselves; if need be, obtain the necessary information from the products' sales representative.
  - e. Carefully calculate the exact quantity of the product necessary for the treatment and establish the volume of water to be used for the intervention.
  - f. Check that the product is available in a quantity sufficient to complete the intervention.
  - g. Read the product's utilisation instructions carefully, in order to ascertain the usage conditions, the correct dosage and the expiration dates.
  - h. Make sure of the parameters necessary to the adjustments of the machine and determine the exact dose of product to be applied to every loading. Follow the instructions of the publication titled "The low volume - Instructions for sprayers adjustment" as well as those contained in the use and maintenance book-let of the distribution device.

## 11.2 - PREPARATORY OPERATIONS TO TREATMENT



**THE FILLING MUST BE CARRIED OUT WITH THE MACHINE ON A FLAT SURFACE. BEFORE THE OPERATION, IN THE ALLOCATED AREA, THE DOSES OR MIXTURES TO BE Poured IN THE TANK MUST BE MADE READY.**

**Before starting the filling cycle, check:**

- the **EFFICIENCY** of the Distribution device (HEAD);
- that the **SPRAYING POINTS (DIFFUSERS) ARE CLEAN**;
- that the **CARTRIDGE AND THE DELIVERY FILTER (P6) ARE CLEAN**
- **AXLE AND WHEELS: SCREWS AND BOLTS TIGHTENING**;



The **hydraulic** and the **pneumatic** circuits mounted inside the tank, allow to realize a **double agitation system**: with the pump water and with the fan air, **at the same time**. The pneumatic circuit can be excluded, when the products used have a quite strong foaming effect, by closing the pneumatic agitator cock. When that cock is opened again, check that the air outlet holes aren't obstructed.



It is advised however to also use always the pneumatic agitator, adding to the mixture, if necessary, a antifoam product.



Before starting the treatment it is essential to agitate the mixture in the tank, re-circulating it completely for as long as it takes to make it homogeneous.



The agitation has to be carried out with the pressure regulator (P5) completely open. Also the cock of the pneumatic regulator has to be open. This operation is of main importance, in order to get a uniform distribution of the active principle on the whole vegetative surface to be treated.

Should the activity need to be interrupted during a treatment with the sprayer, keep the agitator activated until the treatment is resumed. Should this be stopped and deferred to a later stage, the mixture that has remained in the tank must be **agitated again** properly.

**THE MIXTURE AGITATION HAS TO BE CARRIED OUT WITH THE POWER TAKEOFF RUNNING AT A RATE OF AT LEAST 500 RPM.**

## 10 TANK AND HYDRAULIC CIRCUIT DRAINING



- Stop the tractor and remove the key from the control panel.
- Wear suitable protective clothing and accessories in order to avoid contamination by contact or inhalation of the mixture.
- Carry out the discharging in a suitable and properly geared area for the collection of the washing liquid.

**This operation has to be carried out with the 3-way cock P3:**

1. Position the lever of the 3-way cock (P3) to "a" (draining closed).
2. Unscrew the drainage plug.
3. Turn the lever to position "b" (draining open).
4. When the draining is completed, position again the lever of the 3-way cock (P3) to "a" (draining closed), and screw again the chain plug.

On the drawbar, a bracket is prearranged for housing the transmission shaft, when the sprayer isn't hitched to the tractor. A spring supports the coupling triangle, when it isn't inserted in the hoister arms. The frame features are the same ones of the frame to be used with the standard drawbar see paragraph 4.1)

## 4.3 - FAN SERVO AMPLIFIER

It is positioned in the unit front section and protected by a plastic casing.

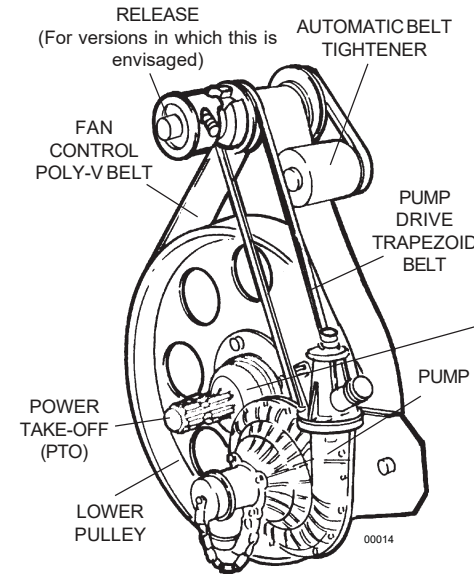

### Servo amplifier

A free-wheeling gear is included between the Power Take-off of the servo amplifier and the fan control pulley (refer to the picture). In case of sudden decelerations or unexpected engine stoppage, this allows the fan to continue its free rotation, thus avoiding extreme mechanical stresses to be transmitted to the drive members.

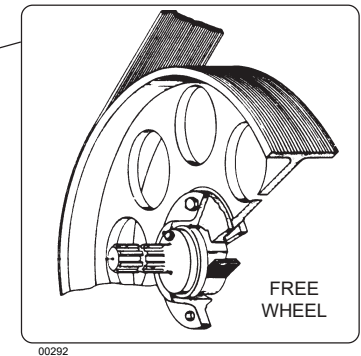

### Centrifugal fan

The front-engaging clutch assembled on the fan shaft allows the operation of the centrifugal pump without the fan (for versions in which this is envisaged).

An air intake predisposed on the casing external edge is connected, by means of a pipe equipped with a cock, to the tank inner agitator. Through this tap it is possible to carry out or exclude pneumatic agitation.

The closed vanes-type impeller is realized in dynamically balanced sheet steel; the air intake opening on the casing is protected by a grating, especially foreseen for this purpose.

The closed vanes-type impeller is realized in dynamically balanced sheet steel; the air intake opening on the casing is protected by a grating, especially foreseen for this purpose.

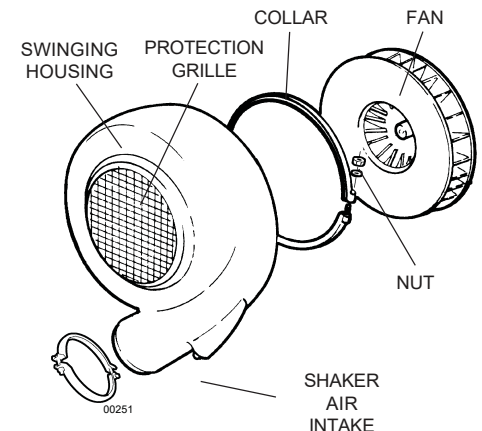

### 4.4 - HYDRAULIC CIRCUIT COMPONENTS

**LEGEND:**  
 P - E = elements of the circuit  
 T = piping

*\*For versions in which this is envisaged*

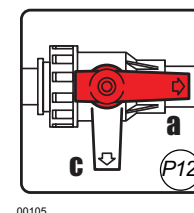
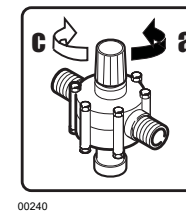
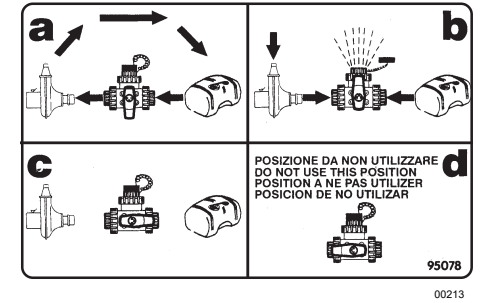
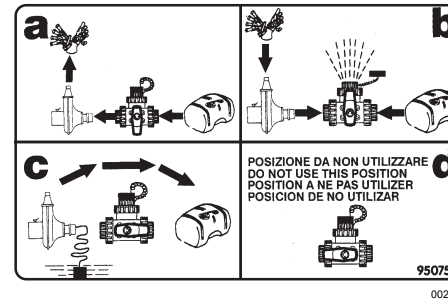
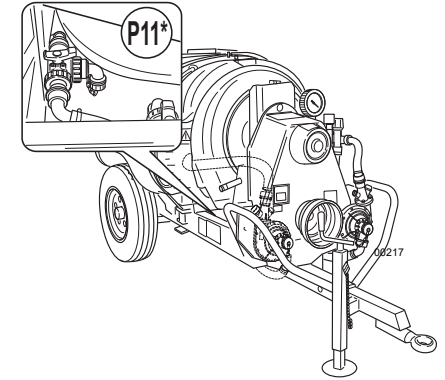
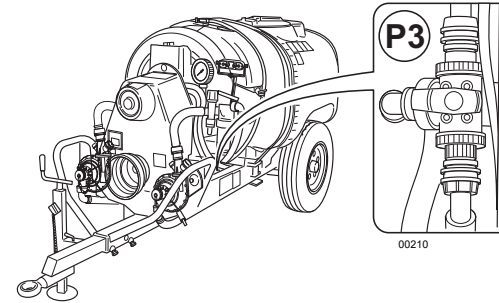
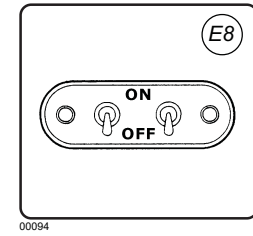
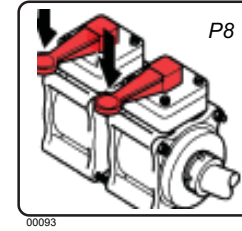
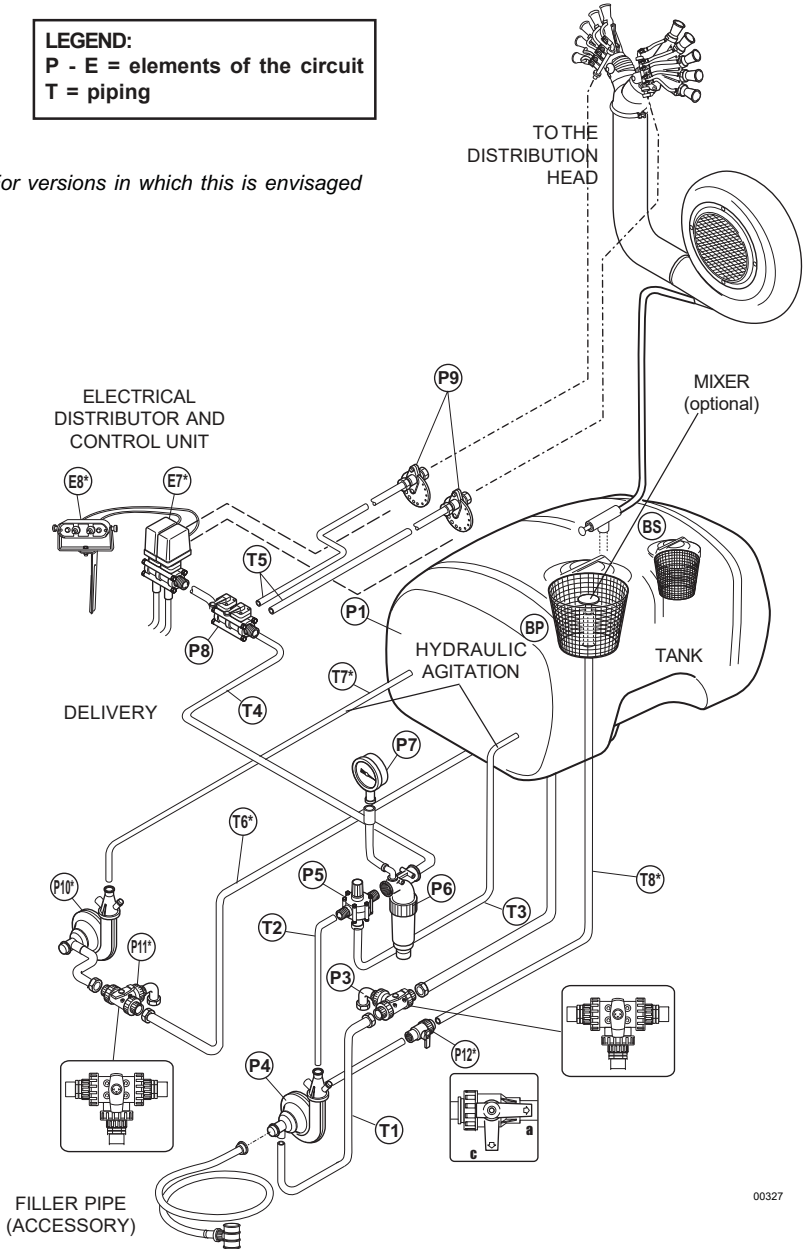

11. Completely open the pressure regulator (P5), by turning the handle anti-clockwise.
12. Through the secondary filler (BS), pour into the tank about 15/20 litres of water: that quantity must be enough TO FILL the pipe and TO PRIME the pump (P4).
13. Start the tractor and engage the PTO; then bring it up to a 500 r.p.m. rotation rate.
14. When the pump will have started the recycling of the poured water, close the cock (P3), by positioning the lever to "B", in order to start the filling through the return pipe (T3).



**15a. WITH MEDICINE MIXTURES OR LIQUID PRODUCTS (WHEN NOT USING THE MIXER)**

- 15a1. Pour the medicine mixture foreseen for every loading (and the possible washing water for the medicine packs and for the instruments used for preparing the mixture) into the main filler (BP).
- 15a2. Close the main filler (BP) of the tank and wait until the filling is completed.

**15b. WITH POWDER PRODUCTS, WHEN USING THE MIXER (IF FORESEEN)**

- 15b1. Pour the powder medicine dose into the cup-like filter of the main filler (BP).
- 15b2. Close the main filler (BP) and the secondary filler (BS) of the tank.
- 15b3. Open the cock (P12), by positioning the lever on "a" and wait until the filling is completed.
- 15b4. Close the cock (P12), by positioning the lever on "c".
16. Disengage the PTO.
17. Completely close the pressure regulator (P5), by turning the handle clockwise.
18. Remove the filling pipes from the pump (P4) and position again the closing plug.
19. Completely open the pressure regulator (P5), by turning the handle anti-clockwise.
20. Position the lever of the 3-way cock (P3) to "A".
21. Engage the Power Takeoff and move to the treatment place, keeping the Power Takeoff running rate at least 500 RPM during all the way.

**IN THE AREA OF THE TREATMENT:**

22. Disengage the power take off (PTO).
23.   **STOP THE TRACTOR AND REMOVE THE KEY FROM THE CONTROL PANEL.**
24. Make sure that the fan is stopped. Hook the fan to the servo amplifier as indicated at point 8.1.b., then mount back the release mobile protection cover.
-  **Properly tighten the screw nut securing the mobile protection cover.**
25. Start the tractor.
26. Engage the Power Takeoff and set it up to a running rate of at least 500 r.p.m., in order to carry out a further agitation.
27. Regulate the operating pressure, by acting on the pressure regulator (P5).
28. CARRY OUT THE TREATMENT.

**P1. TANK**

Tanks utilised:  
polyethylene tanks of 600, 800, 1000, 1500 and 2000 litre capacity

Each tank is made up of:

- tank main filler (BP) with overturning cover having a diameter of 355 mm, with breather pipe. Plastic cup-like filter: 302 mm external diameter, height 254 mm (powder mixing device, on request);
- supplementary tank filler with 250 mm diameter screw-type lid, for filling with clear water and plastic cup-like filter: external diameter 204 mm, height 240 mm;
- transparent level indicator external pipe with graduated scale, (One on the left-hand side of the tank L1 and one on the front side L2);
- hydraulic agitation connected to the return piping (T3);
- pneumatic agitation;
- piston cock, positioned over the tank and connected through a pipe to the air inlet, which is placed on the fan casing, for opening/closing the pneumatic agitation (only for sprayers with 600 and 800 litres tanks);
- ball cock, placed on the pipe connecting the air intake, which is positioned on the fan casing, with the coupling in the tank upper section, for opening/closing the pneumatic agitation (only for sprayers with 1000, 1500 and 2000 litres tanks).
- additional 15 litres hands-washing tank, realized in polyethylene, with external utility cock.

**A = OPEN**  
**C = CLOSED**

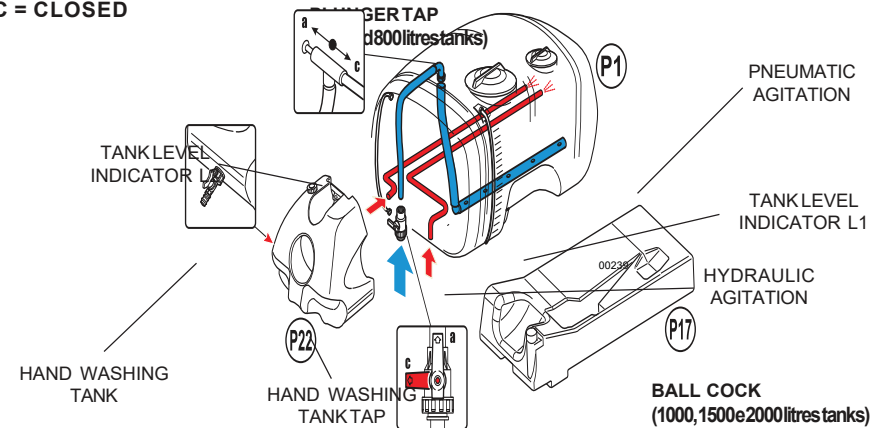

**T1. SUCTION PIPING**

It connects the main tank with the centrifugal pump (P4). In the connecting pipe between the tank and the pump, the 3-way cock (P3) is inserted.

**P3. 3-WAY LEVER TAP A WITH DISCHARGE FITTING**

Positioned on the pipe (T1), between the tank (P1) and the pump (P4), it is equipped with a closing plug of the discharge fitting, with the relevant safety chain. The 3-way lever (P3) can be positioned as here following specified:

### a – Treatment

The liquid gets out from the tank (P1) and is sucked by the pump (P4); this is the **NORMAL** operating position, which is used in order to carry out the treatment and/or to keep the mixing on. The discharge fitting **is closed**.

### b – Drainage

In this position, it is possible to empty: the tank (P1), the pump (P4) and all the pipes of the hydraulic circuit.

### c – Filling

After having closed the discharge fitting by means of the relevant plug equipped with the safety chain, this position is used in order to fill the tank through the especially foreseen pipe, to be applied to the fitting on the pump (P4). Both the discharge fitting, by means of the safety chain, and the pump suction from the tank are closed. When the cock is on that position, it is moreover possible to remove the pump (P4), also when the tank is loaded

### d - POSITION NOT TO BE USED!

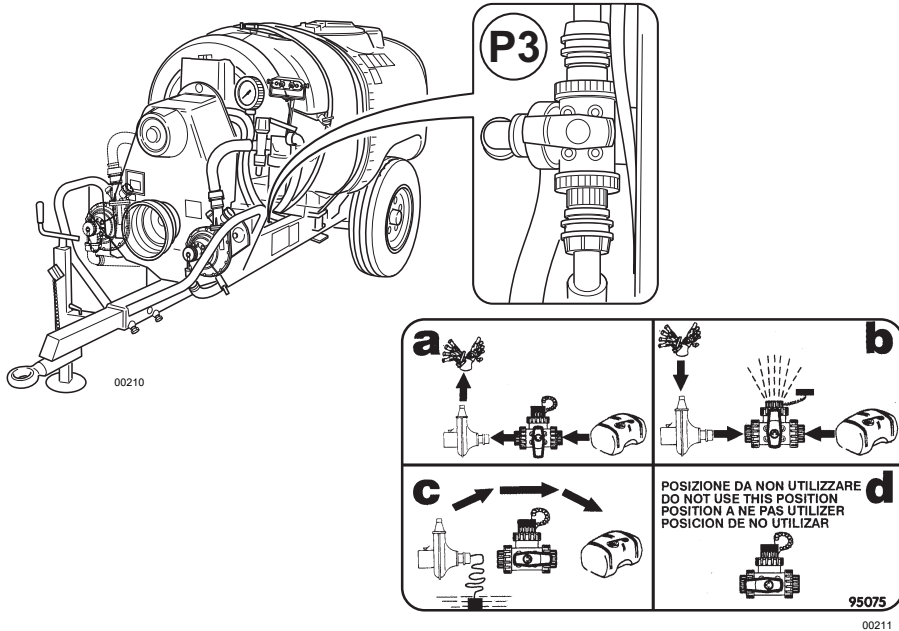

## P4. CENTRIFUGAL PUMP

Fastened on the unit left front section, it is connected with the 3-way cock (P3) and with the pressure regulator (P5).



**THE PUMP HAS NEVER TO RUN DRY**

## T2. PUMP (P4) DELIVERY PIPE

It connects the pump (P4) with the pressure regulator (P5).

9b2. Close the main filler (BP) of the tank.

9b3. Open the cock (P12), by positioning the lever on “a”.

9b4. Complete the filling with water, then close the cover of the secondary filler (BS).

9b5. Close the cock (P12), by positioning the lever on “c”.

10. Move to the place to be treated, by keeping the mixture agitation at a 500 r.p.m. PTO turning rate along the whole way.

### FILLING DIRECTLY IN THE TREATMENT AREA:

11. Disengage the drive outlet (PTO).

12. **Stop the tractor and remove the key from the control panel.**

13. Make sure that the fan is still. Engage the impeller to the multiplier, as indicated at paragraph 8.1, then close again the protection mobile cover.



**Tighten the protection-securing nut properly.**

14. Start the tractor.

15. Engage the Power Takeoff and set it up to a running rate of at least 500 r.p.m., **in order to carry out a further agitation.**

16. Regulate the operating pressure, by acting on the pressure regulator (P5).

16. CARRY OUT THE TREATMENT.

## 8.3 - FILLING WITH THE SPECIFIC PIPE



**Before utilisation, check the operation and proper sealing of the bottom-drawing valve by pouring water in the piping.**



**THE PUMP MUST NEVER RUN DRY**

### EXECUTION:

1. Disengage the fan, see point 8.1.a.

2. For the versions on which it is foreseen: check that the cock (P11) is open: (lever positioned on “a”).

3. Position the lever of the 3-way cock (P3) to “B”.

4. Close the cocks of the 2-way distributor:

a. if manual (P8), the levers are to be lowered (horizontally positioned);

b. if electric, position to “OFF” the quick-break switches (E7).

5. For the versions on which it is foreseen: close the cock (P12), by positioning the lever on “c”.

6. Completely close the pressure regulator (P5), by turning the handle clockwise.

7. Check that the drainage opening on the cock (P3) is closed by means of the relevant plug with safety chain.

8. Connect the filling pipe to the pump (P4).

9. Immerse the filter with the bottom-drawing valve in the water to be loaded.





**The filter must always be below the level of the water to be loaded. The piping must never be above the pump's suction point and must never be excessively bent in the vertical direction.**

10. Position the lever of the 3-way cock (P3) to “a”.

### 8.1.b Fan engagement to perform the treatment

#### EXECUTION:

1. Disengage the power take off (PTO) and rest the machine on the ground.
2.   **Stop the tractor, remove the key from the control panel and check that the fan is stopped.**
3. Undo the mobile protection cap's fixing nut and rotate it so as to access the disengaging element.
4. Fully press the spring push button, push the front body forward, if necessary, turning it to the right or left, until the frontal teeth of the joint engage the corresponding teeth of the pulley; at the same time, the spring push button must return to the outward position. This way, the body is again integrated with the pulley, thus transmitting the movement to the fan.
5. Reposition the mobile protection cover and suitably tighten the securing nut.
6. Start the tractor.

### 8.2 - FILLING THROUGH POURING FROM THE TOP



For this type of filling, use the supplementary filler (BS) located in the upper side of the tank, towards the rear of the sprayer.

**THE INLET OF THE FILLER PIPING MUST NEVER COME INTO CONTACT WITH THE ANTI-PARASITIC MIXTURE: IT MUST ALWAYS BE KEPT AT A SAFE HEIGHT ABOVE THE TANK FILLER AND MUST BE EQUIPPED WITH A NON-RETURN VALVE.**



**THE PUMP MUST NEVER RUN DRY**

#### EXECUTION:

1. Disengage the fan: see point 8.1.a.
2. Position the lever of the 3-way cock (P3) to "a".
3. Completely open the pressure regulator (P5), by turning the handle anti-clockwise.
4. For the versions on which it is foreseen: position the three-way cock (P11) lever of the additional agitation pump (P10) on "a".
5. Close the cocks of the 2-way distributor:
  - a. if manual (P8), the levers are to be lowered (horizontally positioned);
  - b. if electric, position to "OFF" the quick-break switches (E7).
6. For the versions on which it is foreseen: close the cock (P12), by positioning the lever on "c" (lever across-positioned).
7. Pour some water into the tank, for about 1/3 of its capacity, by acting from the secondary filler BS.
8. Start the tractor and engage the PTO; **then bring it up to a 500 r.p.m. rate.**

#### 9a. WHEN NOT USING THE MIXER (WITH MEDICINE MIXTURES OR LIQUID PRODUCTS)

- 9a1. Pour the medicine mixture foreseen for every loading (and the possible washing water for the product packs and for the instruments used for preparing the mixture) into the main filler (BP).
- 9a2. Close the main filler (BP) of the tank.
- 9a3. Complete the filling with water, then close the cover of the secondary filler (BS).

#### 9b. WITH POWDER PRODUCTS, WHEN USING THE MIXER (IF FORESEEN)

- 9b1. Pour the powder medicine dose into the cup-like filter of the main filler (BP).

### P5. PRESSURE REGULATOR

It is connected to the delivery filter (P6) and, through pipe (T3), to the tank (P1). It regulates the operating pressure, by controlling the return flow to the tank.

- **By closing it: it REDUCES the return flow** to the tank and therefore, the agitation of the mixture, and increases the operating pressure and the capacity flow to the head (rotate the handle clockwise).
- **By opening it: it INCREASES the return flow** to the tank and therefore, the agitation of the mixture, while reducing the operating pressure and capacity flow to the head (rotate the handle anti-clockwise).

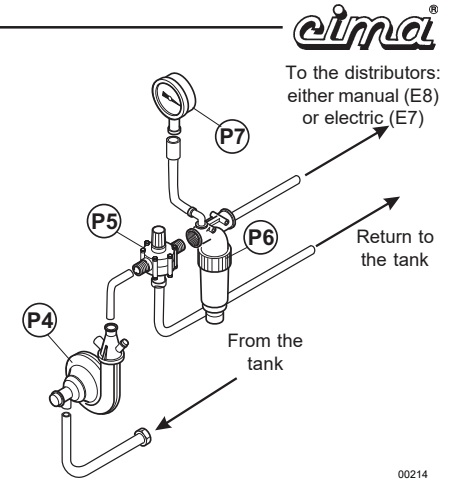

When treatments are carried out with heavy powder products, which have a tendency to form a deposit on the tank bottom, it is necessary to operate with a working pressure of 1 – 1,5 atm, in order to get a better hydraulic agitation of the mixture.

### T3. RETURN TO TANK PIPING

It connects pressure regulator (P5) to tank (P1), at the point on which the hydraulic agitation is mounted.

### P6. FILTER

It is connected to pressure regulator (P5) and, through pipe (T4), to the distributor (P8/E7).

The filter has a filtering capacity of 250 l/min., with a 50 mesh cartridge.

The dirty cartridge causes the operating pressure chute.

This inconvenient is signalled by the pressure gauge.

Mounted on the feeding pipe, it only filters the delivery flow to the heads, by sensibly reducing the possibility for the cartridge to get obstructed.

### P7. GAUGE

Glycerine-dipped, with dial from 0 to 6 Kg/cm<sup>2</sup> (atmosphere) – adjustments scale of 1/10 of atmosphere, 100 mm diameter; it is connected to filter (P6).



Set the working pressure keeping the P8 (or E7) distributors opened.

### T4. PIPING FOR THE FEEDING

It connects the filter (P6) to the manual distributor (P8) or electric distributor (E7).

## P8. MANUAL DISTRIBUTOR WITH 2 LEVER-OPERATED TAPS

It connects the feeding pipe (T4) to the distribution piping (T5). It remote-controls the closing and opening of the pulverising. The mount bracket, supplied with the machine, must be secured to the tractor within the driver's reach.

When the machine is not hitched to the tractor, it must be placed on the forward part of the sprayer's frame.

Each tap permits the spraying from a single side of the head: to the right and to the left respectively. They are **open** when the levers are set in the **vertical** position.

They are **closed** when the levers are **horizontal**.

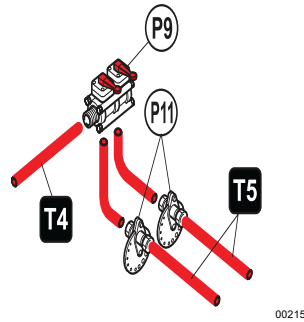

## E7. ELECTRICAL DISTRIBUTOR WITH TWO SOLENOID VALVES

It is connected with the feeding pipe (T4), the distribution pipes (T5) and the electrical unit (E8), which is fastened on the tractor. The solenoid valves open and close themselves, according with the action carried out on the electrical control unit switches.

## E8. CONTROL UNIT

It is electrically connected to the distributor with 2 motorised solenoid valves (E7) and to the main socket of the tractor. The control unit is supplied with a complete electrical plug, should the one present on the tractor be unsuitable for connection.

The 2 lever switches, controlling the solenoid valves (E7), have to be set to "ON" for opening and to "OFF" for closing.

The control unit is equipped with a bayonet support to be inserted in the bracket provided. This must be mounted on the tractor, within the driver's reach. When the machine isn't hitched to the tractor, it must be placed in the position foreseen on the forward part of the machine frame.

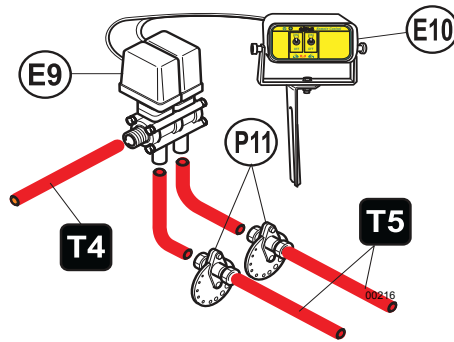

## T5. DISTRIBUTION PIPING

It connects the distributor (P8/E7) to the calibration disc (P9) assembled on the distribution devices.

## P9. CALIBRATION DISC

It selects the flow rates necessary to the treatment and is mounted on the distribution devices. It is made up of 2 flanges, held in position by two butterfly nuts, locking a disc with calibrated holes numbered from 1 to 15. A groove on the edge of the disc allows the exact positioning of the hole to be utilised.

**FILLING MUST BE CARRIED OUT WITH THE MACHINE ON A FLAT SURFACE. ON THE SITE, BEFORE THE OPERATION, THE DOSES OR THE MIXTURES TO BE Poured INTO THE TANK MUST BE PREDISPOSED.**





**IT IS NECESSARY TO ALWAYS MAKE USE OF PERSONAL PROTECTION.**

## 8.1 - FOREWORD - USE OF THE FAN DISENGAGEMENT (For versions in which this is envisaged)

### 8.1.a Disengagement of the fan

EXECUTION:

1.   Stop the tractor, remove the key from the control panel and check that the fan has stopped.
2. Undo the mobile protection cap's fixing nut and rotate it so as to access the disengaging element.

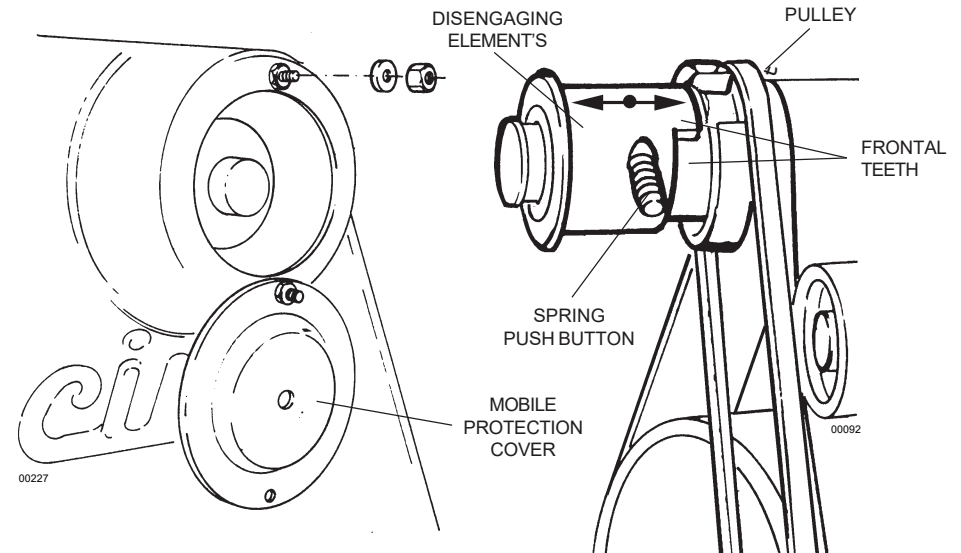

3. Fully press the spring push button and pull the front element until it springs out. The body disengaged from the retaining joint must turn freely: the pump will operate and the fan will thus be excluded.
4. Reposition the mobile protection cover and fasten the locking nut properly.
5. Start the tractor and carry out the filling operation.

### 7.1 - FILLER PIPE

The pipe is provided with a coupling elbow fitting and with a **bottom-drawing valve**. This is used for the filling of the tank. It must be screwed into place on pump (P4) instead of the chain-held stopper.



The assembly has **ALWAYS** to be carried out with the P3 cock positioned on "C".



Before making use of it, it is necessary to check the operation and the proper sealing of the bottom-drawing valve, by pouring water into the pipe.

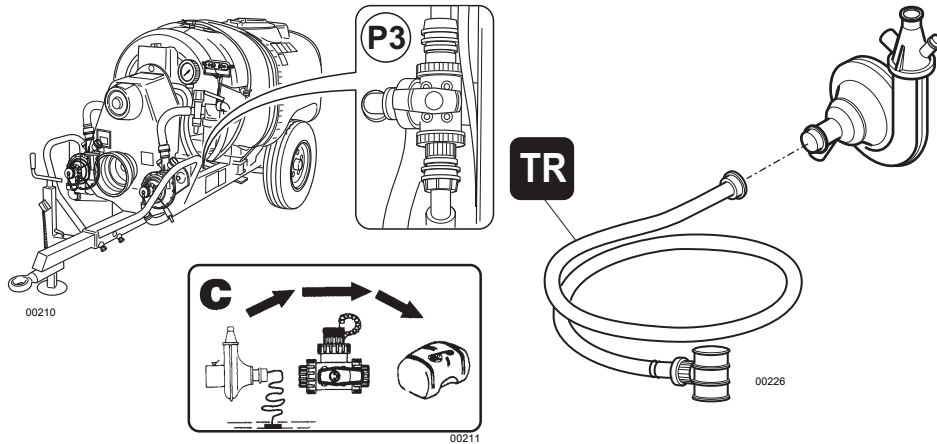

### 7.2 - ELECTRICAL TURN DEVICE

It is an accessory utilised to modify the direction of the pulverising. It can be used only with some types of distribution devices.



All indications and instructions are provided in the use and maintenance booklet of the distribution devices with which it can be used.

### 7.3 - VANE-TYPE MECHANICAL AGITATOR



All the indications and instructions are supplied in the use and maintenance booklet, provided with this accessory upon request.

Its number must appear in the flange's semi-circular seat. The rotation of the disc is obtained by loosening the butterfly nuts by a few turns. After the operation is done, screw back carefully.



Any faulty sealing condition of the hydraulic circuit causes an intermittent issuing of the sprayed material. It is necessary to carefully check the efficiency of the sealers and clamps, the tightening of the ring nuts and fittings and the good working condition of the piping.

### P10. ADDITIONAL AGITATION PUMP (For the models on which it is foreseen)

Fastened on the machine right front side, it is connected with the tree-way cock (P11) on the suction side and with the tank (P1) on the delivery side.



**THE PUMP HAS NEVER TO OPERATE DRY.**

### T6. SUCTION PIPE

It connects the main tank (P1) with the centrifugal pump (P10). On the suction pipe, the cock (P11) is inserted.

### T7. PUMP DELIVERY PIPE

It connects the centrifugal pump (P10) with the main tank (P1).

### T8. PIPING FOR MIXING

(For the models on which it is foreseen)

It connects the centrifugal pump (P4) with the mixer. On the mixer pipe, the cock (P11) is inserted.

### P11. ADDITIONAL PUMP 3-WAY LEVER TAP (For the models on which it is foreseen)

Positioned on the pipe (T6), between the centrifugal pump (P10) and the main tank (P1), it is equipped with a closing plug of the discharge fitting, with the relevant safety chain. The control lever can be set to the following positions:

#### a - Agitation

Le liquid gets out from the tank (P1) and is sucked by the pump (P10), then, through the delivery pipe (T7) it returns to the tank, so provoking a further hydraulic agitation of the mixture. **The drainage is closed.**

#### b - Drainage

On that position, the following components are drained: the tank (P1), the pump (P10) and the pipes of the hydraulic circuit for the additional agitation (T6 and T7). Use that position **ONLY** in order to drain the tank and the hydraulic circuit for the additional agitation.

**c - Stop**

On that position, the suction of the additional pump (P10) is closed. The drainage closing by means of the special plug with chain, prevents the tank from getting drained.

**d - POSITION NOT TO BE USED!**

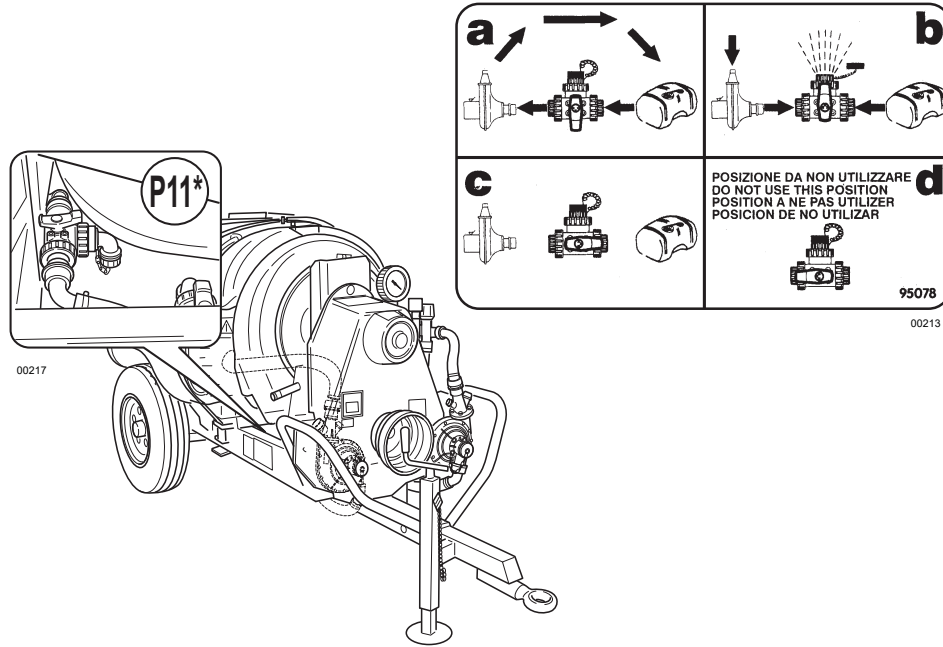

**P12. LEVER TAP**

Positioned on the pipe (T8), between the main tank (P1) and the centrifugal pump (P4), it can assume the following positions:

**a - Open**

From the centrifugal pump (P4), the liquid is sent to the mixer positioned on the bottom of the cup-like filter of the main filler (BP).

**b - Closed**

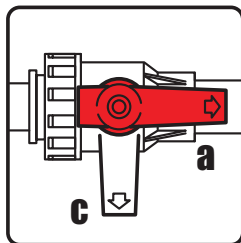

00105

**6.2 - ELBOW FITTINGS OF DISTRIBUTION DEVICES**

The elbow fittings both support and connect the distribution devices with the fans. All the trailed-mounted sprayers' outlets are rear-positioned, placed down and vertically disposed, provided that no additional accessory is mounted, which could possibly modify their position.

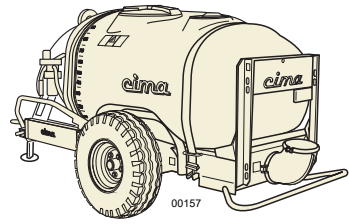
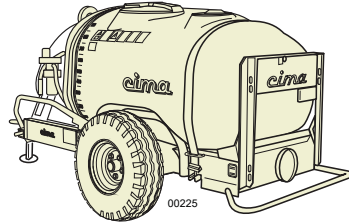
COMPLETE SERIES	BLITZ 45T - BLITZ 50T	BLITZ 55T - 55TS - 55TE
Fan outlet opening	Inside diameter: 175 mm	Inside diameter: 250 mm
STANDARD BASIC MODELS		
Sprayers delivered:	90° ELBOW	WITHOUT ELBOW
Outlet opening	VERTICAL back	HORIZONTAL back



In the use and maintenance book-let of every distribution device the type of elbow necessary for the connection is specified together with the assembling instructions.





Every distribution device is supplied with its own **USE AND MAINTENANCE** booklet that is, or will have to be, attached to this publication and will constitute one of its integral parts.

### 6.1 - TYPES AND IDENTIFICATION CODES

Distribution device - Head	BLITZ 45T	BLITZ 50T 1000	BLITZ 50T 1500	BLITZ 55T BLITZ 55TS	
				BLITZ 55T	BLITZ 55TS
4+4 diffuser head with 8 taps	T4+4.45.01	T4+4.50.01	T4+4.50.01	-	-
5+5 diffuser head with 10 taps	T5+5.45.01	T5+5.50.01	T5+5.50.01	-	-
4+4 diffuser head with 8 taps Strasbourg type	T.ST4.45T.01	T.ST4.50T.01	-	-	-
7 diffuser canopy head	T.TND.45.01	T.TND.50.01	T.TND.50.01	-	-
Mide head with extension of 600 mm	T.MD.P06.45.01	T.MD.P06.01	-	-	-
2-fishtail sprayhead with 3 sectors largelight	T.2V.3S.45T.02	T.2V.3L.50T.02	T.2V.3L.50T.02	T.2V.3L.55T.02	T.2V.3L.55T.02
2-fishtail sprayhead with 4 sectors	-	T.2V4.50T.01	T.2V4.50T.01	T.2V4.55T.01	T.2V4.55T.01
2-fishtail sprayhead with 8 sectors	-	-	-	T.2V8.55T.01	T.2V8.55T.01
4-fishtail sprayhead	-	T.4V.50T.10.02	T.4V.50T.15.02	T.4V.55T.02	T.4V.55T.02
4-fishtail sprayhead	-	T.6V.50T.10.02	T.6V.50T.15.02	T.6V.55T.02	T.6V.55TE.02
Tobacco cannon jet with extension of 600 mm	TGC.P06.45.02	-	-	-	-
Tobacco cannon jet (multiple diffuser) with extension of 600 mm	-	TGC.P06.50.02	TGC.P06.50.02	-	-
Tobacco cannon jet (multiple diffuser) with 90° elbow and extension of 500 mm	-	-	-	TGC.P05.55.01	TGC.P05.55.01
Tobacco vertical cannon jet with 90° elbow and extension of 800 mm	-	-	-	T.GCV.P08.01	T.GCV.P08.01
Tobacco flexible cannon jet	T.GCF.45.01	T.GCF.50.01	T.GCF.50.01	-	-
Olive multiple head with 4 diffuser	T.OL.000.45.01	T.OL.000.50.01	T.OL.000.50.01	T.OL.000.55.01	T.OL.000.55.01
Olive multiple head with 4 diffuser and extension of 600 mm	T.OL.P06.45.01	T.OL.P06.50.01	T.OL.P06.50.01	-	-
Olive multiple head with 4 diffuser with 90° elbow and extension of 500 mm	-	-	-	T.OL.P05.55.01	T.OL.P05.55.01
Potatoes head with 90° elbow	-	-	-	T.PT5.55T.02	T.PT5.55T.02
Tomatoes head with 90° elbow	-	-	-	T.PM.55T.02	T.PM.55T.02
2 lower hands and 2 upper flexible cannons head	TC.2M2C.45T.01	TC.2M2C.50T.01	TC.2M2C.50T.01	TC.2M2C.55T.01	TC.2M2C.55T.01
2 lower hands and 4 upper cannons head	TC.2M4C.45T.01	TC.2M4C.50T.01	TC.2M4C.50T.50	TC.2M4C.55T.01	TC.2M4C.55T.01
2 lower hands and 2 upper cannons head, France type	TCF.2M2C.45T.02	TCF.2M2C.50T.02	TCF.2M2C.50T.50	TCF.2M2C.55T.02	TCF.2M2C.55T.02
2 lower hands and 4 upper cannons head, France type	TCF.2M4C.45T.02	TCF.2M4C.50T.02	TCF.2M4C.50T.50	TCF.2M4C.55T.02	TCF.2M4C.55T.02
2 hands and 4 cannons head with hydraulic control	TCI2M4C.45T.11	TCI2M4C.50T.11	TCI2M4C.50T.11	TCI2M4C.55T.11	TCI2M4C.55T.11
4 hands head (2 lower and 2 upper)	TC.2M2M.45T.01	TC.2M2M.50T.01	TC.2M2M.50T.01	TC.2M2M.55T.01	TC.2M2M.55T.01
Coffee head	T.CA.45T.01	T.CA.50T.01	T.CA.45T.01	-	-

BLITZ06

## 4.5 - TECHNICAL DATA

### 4.5.1-Sprayer dimensions and weights

(Whith drawbar and protection ring - whitout didtribution device)

		Tank capacities (litres)				
		600	800	1000	1500	2000
<b>BLITZ 45T</b>	Total width(mm)	1060	1090	1380	-	-
	Total height (mm)	1250	1370	1370	-	-
	Lenght (mm)	3050	3310	3350	-	-
	Weight, empty (kg)	342	380	420	-	-
	Weight, full load ( kg)	966	1204	1444	-	-
<b>BLITZ 50T</b>	Total width(mm)	1060	1090	1380	1660	-
	Total height (mm)	1250	1370	1370	1480	-
	Lenght (mm)	3100	3370	3430	4300	-
	Weight, empty (kg)	374	412	450	550	-
	Weight, full load ( kg)	998	1258	1500	2125	-
<b>BLITZ 55T BLITZ 55TS BLITZ 55TE</b>	Total width(mm)	-	-	1530	1660	1720
	Total height (mm)	-	-	1440	1480	1720
	Lenght (mm)	-	-	3450	4300	4300
	Weight, empty (kg)	-	-	489	580	608
	Weight, full load ( kg)	-	-	1539	2155	2708

BLITZ001



Weight of the steering drawbar kg 38: to be added to the weight of the sprayer, when it is used. The installation of the steering drawbar **DOESN'T** cause any variation of the machine total length.

### 4.5.2 - Wheels: dimensions and operating pressures

MODEL	MEASURE	WHEEL HUB	PRESSURE
BLITZ 45T 600 - BLITZ 50T 600	175/70.13	5 F	atm. 2,5
BLITZ45T 800 - BLITZ 50T 800	7,00-12	5 F	atm. 2,5
BLITZ45T 1000 - BLITZ50T 1000	10/80.12	5 F	atm. 3,3
BLITZ55T-55TS-55TE 1000	10,0/75.15,3	6 F	atm. 3,3
BLITZ45 1500	10/80-12	6 F	atm. 3,3
BLITZ50 1500	10/75-15,3	6 F	atm. 3,3
BLITZ50T-55T-55TS-55TE 1500	10,0/75.15,3	6 F	atm. 3,3
BLITZ55T-55TS-55TE 2000	11,5/80.15,3	6 F	atm. 3,3

BLITZ002

### 4.5.3 - Technical specifications for fans and pump Centrifugal Fan

	BLITZ 45T	BLITZ 50T	BLITZ 55T	BLITZ 55TS	BLITZ 55TE BLITZ 55 T
Fan Diameter (mm)	450	500	550	550	550
Fan speed (giri/min.)	4500	4000	3450	3720	3900
Air flow rate (m <sup>3</sup> /h)	5400	7550	12500	14000	15500
Air speed (m/s)	188	175	150	170	180
Power absorbed (kW)	17	24	28	36	43



The performance specified is obtained with the drive outlet (PTO) at 540 RPM. For a good result of the treatments this condition **MUST ALWAYS BE OBSERVED** during the machine's operation. Utilisation is permitted with speed rates ranging between 500 and 620 RPM.

	BLITZ 45T	BLITZ 50T	BLITZ 50T1500	BLITZ 55T	BLITZ 55TS	BLITZ 55TE
Steel fan	si	si	si	si	si	si
P.E. Casing	si	si	si	si	si	si
90° Joining elbow	si	si	si	-	-	-
Internal diameter casing outfeed (mm)	175	175	175	250	250	250
PTO shaft 1"3/8 SAE (DIN 9611/A)	si	si	si	si	si	si
Main pulley diameter (mm)	450	480	480	480	480	480
Fan control belt	650J32	690J50	690J50	690J50	690J50	690J50
Fan pulley diameter (mm)	54	64,5	64,5	75	70	66
Pump control pulley diameter (mm)	78	88	88	101-96	101-96	88
Pump control belt	3V 500	3V 500	3V 500	3V 500	3V 500	3V 500
Pump pulley diameter (mm)	82,5	82,5	82,5	82,5	88	82,5

### Centrifugal pump CD32

Model C.I.M.A. CD32 – Pressed in nylon – Turning open – Stainless steel shaft – Silicon carbide, stainless steel and viton mechanical seal, – Emptying cork – Oiling device with spring cover - Suction sleeve with supplementary service filler, provided with chain-retained cork. Activated with trapezoid belt driven by the pulley mounted on the fan shaft.

—Speed ..... 4250RPM  
 —Flow rate ..... 140 litres/min.  
 —Maximum pressure ..... 4.5 Kg/cm<sup>2</sup>  
 —Power absorbed ..... kW 2.5

### IN CASE OF BREAKAGE:

1. Stop the tractor and remove the key from the control panel.
2. Close the 2 taps of distributor "P8".
3. Move the 3-way cock (P3) lever to position "C", filling.
4. Close the cock with pressure regulating handgrip (P5) (turn it clockwise).

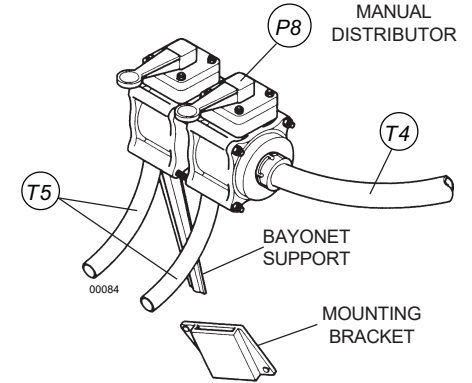

### 5.3.2 - Electrical control panel - E10

1. Mount the securing clamp on the tractor within the driver's reach.
2. Insert the bayonet support of the control panel in the securing clamp.
3. Connect the distribution piping T5 to the hydraulic circuit of the distribution device (head) mounted on the machine (follow the instructions of the specific "use and maintenance" book-let which is supplied with it).
4. Connect the feeding pipe (T4) with the electrical distributor (E7).
- 5 - Connect the main cable "W1" inserting the plug into the mains socket of the tractor.



The mains cable "W1" is provided complete with main socket to be mounted on tractors that might not be equipped with it, or to replace the existing one should it be incompatible with the plug.



Position the electrical cables W1 and W2 in such a way as to avoid risking their being wrenched off during treatments. If necessary, use some securing clamps. A sudden interruption of power will lock the 2 solenoid valves of the electrical distributor "E7". Should this fault take place when they are in the open position, it is necessary to:

- Stop the tractor and remove the key from the control panel.
- Position the cock (P3) to "c".
- Restore the electric current.

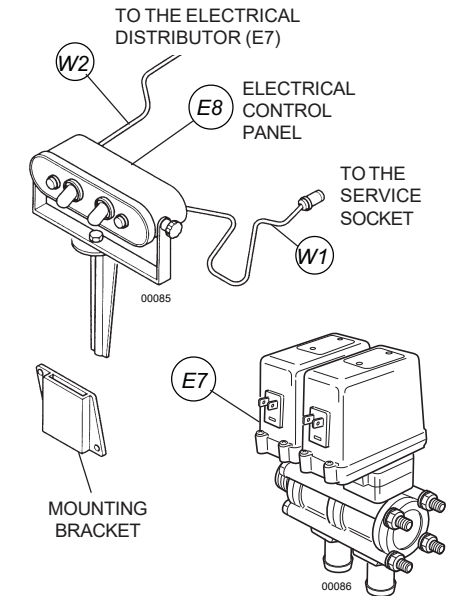

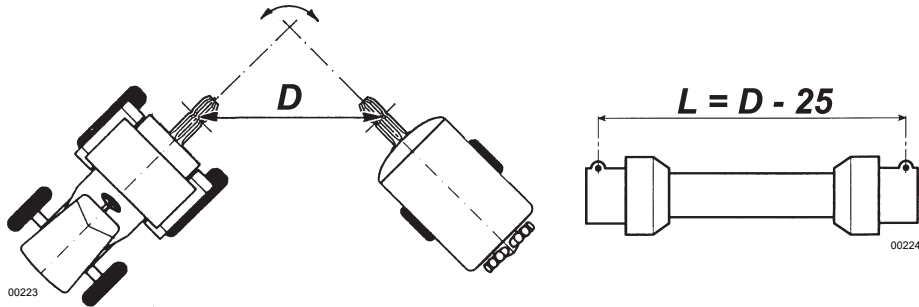

### 5.2.2 - Transmission with a single homocynetic joint (on the machine side) for sprayers with steering drawbar

The transmission shaft mounting has to be carried out when the 2 PTO are coaxial, or, shouldn't this be possible, when their axes are parallel.

These operating conditions can be met by adjusting the height, acting on the tractor hoister.

 **THE HOMOCYNETIC JOINT HAS TO BE MOUNTED ON THE SPRAYER PTO. On these conditions, it is possible to carry out curves having a 70/80° steering angle, with the power takeoff turning.**

 **ANYWAY, THE USER HAS BOTH TO FOLLOW AND TO OBSERVE ALL THE INDICATIONS SUPPLIED IN THE USE AND MAINTENANCE BOOKLET PROVIDED BY THE HOMOCYNETIC CARDAN SHAFT MANUFACTURER.**

**DEFINITION OF THE TRANSMISSION SHAFT LENGTH.**  
- Follow the same procedures described at Paragraph 5.2.1

## 5.3 - INSTALLATION OF REMOTE CONTROLS

### 5.3.1 - Manual 2-tap distributor - P8

- 1 – Mount the securing bracket on the tractor within the driver's reach.
- 2 – Insert the distributor's bayonet support in the securing bracket.
- 3 – Connect the feeding pipe (T4).
- 4 - Connect the distribution piping T5 to the hydraulic circuit of the distribution device (head) mounted on the machine (follow the instructions of the specific "use and maintenance" book-let which is supplied with it).

 **Position the distribution piping T5 and feed piping T4 so as to avoid the risk of suffering damage or breakage during spraying. If necessary, utilise suitable securing clamps.**

## 5 COUPLING MODALITIES 5

### 5.1 - HITCHING TO THE TRACTOR

 Check that the tractor "permissible trailed weight" is compatible with the sprayer weight, when this is fully loaded and complete with the equipments mounted for the treatment (see the Paragraphs "3.1" - "4.5.1" as well as the jointed documents).

 **THE SPRAYER ISN'T HOMOLOGATED FOR CIRCULATING ON ROAD.**





 The tractor's power take-off (PTO), under all utilisation conditions, must provide a power exceeding that absorbed by the sprayer.

Pairing suggested for tractors of at least	BLITZ 45T	BLITZ 50T	BLITZ 55T	BLITZ 55TS	BLITZ 55TE
CV SAE	45	65	70	80	90
kW	33	48	52	59	66

BLITZ005

#### 5.1.1 - Sprayer with standard drawbar

##### EXECUTION

1. The hitching has to be carried out on a plane surface, after having checked that all the people not charged with the operation moved away, as well as the children and the animals possibly present.
2. The tractor drawbar has to be on central position.
3. Drive the tractor near the sprayer and aligned with respect to it.
4.   **Stop the tractor and remove the key from the control panel.**
5. Select the trail eye position: either up or down.  
The sprayer has to operate as horizontally as possible. If the ground allows it, intervene by regulating also the axle height.
6. Position the drawbar trail eye at the height of the trail fork, by acting on the support foot.
7. Start the tractor and insert the trail eye into the trail fork, by following the instructions supplied at step 1.
8.   **Stop the tractor and remove the key from the control panel.**
9. Fasten the drawbar to the frame.
10. Lock the drawbar, by inserting the special peg with safety clip pin.
11. Lift the support foot and detach it from the drawbar.
- 11a. If necessary, regulate the drawbar length by fastening the support foot to the frame (Position B).
- 11b. By acting on the support foot, adjust its height, in such a way that it is possible to let the drawbar slide without any effort; remove the through bolt and loosen the two locking screws. Adjust the drawbar position, then lock it again.
- 11c. Lift the support foot and remove it from the frame.
12. Fasten the support foot to the frame, on stowage position (Position C).





 After every regulation, carefully tighten the screws and the bolt involved in the carried out operation.

13. After having properly fastened the fastening bracket supplied with the equipment, position near the driver either the manual distributor (P8) or the electrical distributor (E8), inserting the power supply cable of the same one into the tractor plug.
14. Screw the two feeding pipes to the distribution device (head).

### 5.1.2 - Sprayer with steering drawbar

#### EXECUTION

1. The hitching has to be carried out on a plane surface, after having checked that all the people not charged with the operation moved away, as well as the children and the animals possibly present.
2. Loosen the chains of the hoister arms.
3. Start the tractor and move the hoister arms to the height of the steering drawbar clip pins.

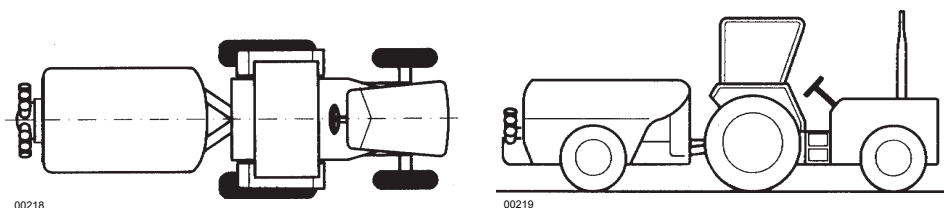

4.   Stop the tractor and remove the key from the control panel.
5. Insert the toggle joints on the machine pegs, locking them there by means of the clip pins.
6. Fasten the 3rd point rod of the tractor on the steering drawbar, locking it there by means of the peg and the clip pin.
7. Completely lift the support foot.
8. Start the tractor and hoist the sprayer, until the 2 PTO are at the same height.
9.   Stop the tractor, remove the key from the control panel and make sure that no one can act on the hydraulic controls of the hoister. Never operate or stand beneath the machine or in the area that could be involved in its sudden lowering.



10. By acting on the 3rd point rod, move the axes of the 2 PTO until they are on the same plane.
11. Block the coupling by tightening the chains of the hoister arms.

 When the operation is completed, the 2 PTO must be positioned on the same axis.

## 5.2 MOUNTING OF THE TRANSMISSION SHAFT

  The mounting, disassembling or possible other interventions on the transmission shaft must be carried out with the engine switched off and with the starter key removed from the tractor's control panel.



USE TRANSMISSION SHAFTS WITH CE CERTIFICATION. OBSERVE THE REGULATIONS CONTAINED IN THE USE AND MAINTENANCE BOOK-LET PROVIDED BY THE SHAFT MANUFACTURER.

### 5.2.1 Cardan transmission shafts

The transmission shaft mounting has to be carried out when the 2 PTO are coaxial, or, shouldn't this be possible, when their axes are parallel. In this case, the misalignment has to be such to PREVENT the transmission shaft articulated joints to operate with an angle exceeding a 15° maximum width.

These operating conditions can be met by acting on the drawbar, which is adjustable both in height and in length.

When some curves are carried out with the power takeoff inserted, the steering angle can be 30° only if the trailing point is equally distanced with respect to the motion drives. Beyond such a value, it will be necessary to disengage the power takeoff, in order to avoid any possible breaks and dangers.

 ANYWAY, THE USER HAS BOTH TO FOLLOW AND TO OBSERVE ALL THE INDICATIONS SUPPLIED IN THE USE AND MAINTENANCE BOOKLET PROVIDED BY THE CARDAN SHAFT MANUFACTURER.

#### DEFINITION OF THE TRANSMISSION SHAFT LENGTH.

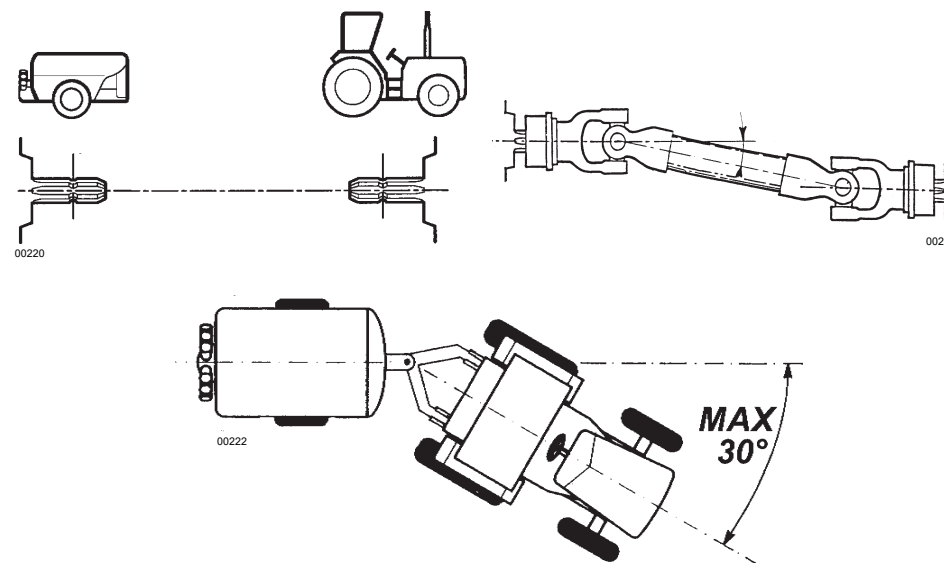

1. After having hitched the sprayer to the tractor, set the operative unit to the maximum steering position allowed.
2. Measure the distance "D" between their grooves.
3. Length "L" of the transmission shaft (refer to the picture) to be deployed, measured between the 2 stopping pawls and with joint closed, must be 25 mm lesser than distance "D": " L = D-25 mm"