

# LOW VOLUME TRAILER SPRAYER

## BLITZ

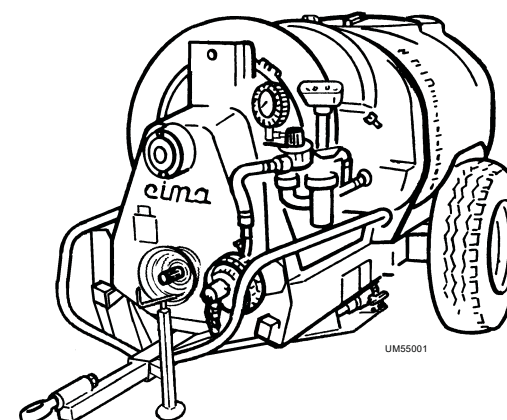

## INSTRUCTIONS FOR USE AND MAINTENANCE

**eima**<sup>®</sup> S.p.A.

27047 S.MARIA DELLA VERSA - PV - ITALIA  
Via Sicilia,2 - Tel. 0385/278223 r.a. - Fax 0385/798184

**eima**<sup>®</sup> S.p.A.

C.I.M.A. S.P.A. UNDERTAKES NO RESPONSIBILITY IN  
CASE OF DAMAGE TO PERSONS OR OBJECTS CAUSED  
BY THE NON-OBSERVANCE OF THE DIRECTIONS AND  
INSTRUCTIONS CONTAINED IN THIS MANUAL AND IN THE  
INTEGRATIVE PAGES THAT ACCOMPANY THE COMPO-  
NENTS COMPLETING THE MACHINE.

**Publication No. UM. BLITZ, MARCH 1996**

 **cima**<sup>®</sup> Sp.A.

27047 S. MARIA DELLA VERSA - PV - ITALIA  
Via Sicilia, 2 - Tel.: 0385/278223 a.s. - Fax: 0385/798184

*Dear Customer, thank you very much!*

*We want to congratulate with you, for having chosen a **cima**® sprayer.*

*Your choice shows the wisdom of the well-informed Purchaser, aware of the fact, that the required features of quality, technique and reliability must be satisfied at the right price!*

*Our continuous engagement in R&D and in testing our machines allows us to realize products able to offer the best performances, a high reliability and a great easiness of use at the same time !*

*Our first goal, is to get our Customers happy for having met us!*

The "Spare parts catalogue" of this sprayer/sprayhead is available in the "restricted area" on website [www.cima.it](http://www.cima.it).

In order to accede, use:

Username: **sprayer**

Password: **844719KE**

Where we are



# LOW VOLUME TRAILER SPRAYER

# BLITZ

Serial No.: .....

## INSTRUCTIONS FOR USE AND MAINTENANCE

***eima***<sup>®</sup> S.p.A.

27047 S.MARIA DELLA VERSA - PV - ITALIA  
Via Sicilia, 2 - Tel.: 0385/278223 a.s. - Fax: 0385/798184

## LIST OF VALID PAGES

This publication is composed of 66 pages divided in the following manner:

PAGENO.	REVISION	ISSUE DATE
from I to IV	00	March 1996
from 1 to 62	00	March 1996

## REGISTRATIONS OF ADDITIONS AND CHANGES

REVISION	DESCRIPTION
00	First Edition, March 1996
01	
02	
03	
04	
05	
06	
07	
08	

20 ENCLOSED: STATEMENT OF CONFORMITY 20



DICHIARAZIONE DI CONFORMITÀ ai sensi della direttiva CEE 89/392 e successive modificazioni		
DECLARATION OF CONFORMITY as per EEC directive: CEE 89/392 and subsequent modifications	DECLARATION DE CONFORMITÉ selon la directive 89/392/CEE et modifications ultérieures	
KONFORMITÄT SERKLÄRUNG im Sinne der Richtlinie 89/392/EWG und nachfolgenden Änderungen	DECLARACIÓN DE CONFORMIDAD con arreglo a la Directiva CEE 89/392 y sucesivas modificaciones	
<b>CIMA S.p.A. - Via Sicilia, 2 - 27047 SANTA MARIA DELLA VERSA (PV)</b>		
dichiara sotto la propria responsabilità che la macchina:		
herewith declares, under their personal responsibility, that the following machine:	déclarons sous notre responsabilité que la machine décrite ci-après:	erklärt hiermit auf eigene Verantwortung, daß das Gerät:
SERIE, TIPO - MODEL, TYPE - SERIE, TYPE - MODELL, TYP - SERIE, TIPO:		
<input style="width: 100%; height: 100%;" type="text"/>		
MATRICOLA - SERIAL NO. - MATRICULE - SERIENNR. - MATRÍCULANº:		
<input style="width: 100%; height: 100%;" type="text"/>		
è conforme ai requisiti essenziali di Sicurezza e di Tutela della Salute di cui alla Direttiva CEE 89/392 e sue successive modificazioni.		
Per la verifica della Conformità di cui alle Direttive sopra menzionate, sono state consultate le seguenti: Norme armonizzate EN:    EN 294    EN 349.		
conforms to the essential safety regulation as well as the Health requirements as per European economic community Directive: CEE 89/392 and subsequent modifications. For the verification of conformity as per above mentioned directives the following official En norms have been consulted: Harmonized EN norms:    EN 294    EN 349.	est conforme aux exigences de Sécurité et de Sauvegarde de la Santé selon la directive 89/392/CEE et modification ultérieures. Pour vérifier la conformité aux directives susmentionnées, ont été prises en compte les normes suivantes: Normes harmonisées:    EN 294    EN 349.	
mit den Grundvoraussetzungen für die Sicherheit und den Gesundheitsschutz laut der Richtlinie 89/392/EWG und nachfolgenden Änderungen übereinstimmt. Zur Überprüfung der Übereinstimmung mit den obengenannten Richtlinien wurden die folgenden Vorschriften konsultiert: EN-angeglichene Normen:    EN 294    EN 349.	cumple con los requisitos esenciales de Seguridad y de Preservación de la Salud contenidos en la Directiva CEE 89/392 y sucesivas modificaciones. Para comprobar la Conformidad a la que se refieren las Directivas anteriormente citadas, se han consultado la siguientes: Normas Armonizadas EN:    EN 294    EN 349.	
Responsabile della Sicurezza - The Security Official - Responsable Sécurité et Homologations - Der Sicherheitsverantwortliche - Responsable de la Seguridad		
Vitali Giampietro 		
Santa Maria della Versa (PV) Data, Date, Date, Datum, Fecha, _____		

UMAP072a

TABLE OF CONTENTS

<b>1</b>	<b>INTRODUCTION</b> .....	<b>1</b>
1.1	PUBLICATION IDENTIFICATION .....	1
1.2	PUBLICATIONS ATTACHED .....	1
1.3	PURPOSE OF THE PUBLICATION .....	1
1.4	REFERENCES TO REGULATIONS .....	1
1.5	USE OF THE MANUAL .....	1
1.6	UPDATES .....	2
<b>2</b>	<b>GLOSSARY</b> .....	<b>3</b>
2.1	TERMINOLOGY .....	3
2.2	ABBREVIATIONS .....	3
2.3	SAFETY DECALS .....	3
<b>3</b>	<b>GENERAL INFORMATION</b> .....	<b>7</b>
3.1	IDENTIFICATION OF THE MACHINE .....	7
3.2	TECHNICAL ASSISTANCE .....	7
3.3	SAFETY WARNINGS .....	7
3.4	SAFETY DEVICES .....	8
3.5	HANDLING OF AGROCHEMICAL PRODUCTS .....	9
3.5.1	Storage .....	9
3.5.2	Specific equipment .....	9
3.5.3	Disposal of empty containers and agrochemical residue .....	9
3.5.4	Personal protection means .....	10
<b>4</b>	<b>STRUCTURAL ANALYSIS OF THE MACHINE</b> .....	<b>11</b>
4.1	DRAWBAR .....	12
4.2	SWIVELLING DRAWBAR (OPTIONAL) .....	13
4.3	FAN DRIVE .....	14
4.4	HYDRAULIC CIRCUIT COMPONENTS .....	15
4.5	TECHNICAL DATA .....	19
4.5.1	Machines dimensions and weights .....	19
4.5.2	Wheels: sizes and working pressure .....	19
4.5.3	Fan-pump functional characteristics .....	19
4.5.4	Fan technical characteristics .....	20
<b>5</b>	<b>COUPLING MODE</b> .....	<b>21</b>
5.1	TRACTOR HOOK-UP .....	21
5.1.1	Sprayer with standard drawbar .....	21
5.1.2	Sprayer with swivelling drawbar .....	21
5.2	PTO SHAFT FITTING .....	22
5.2.1	Pto shafts .....	23
5.2.2	Transmission with a single homokinetic wide angle joint (machine side) .....	24
5.3	INSTALLATION OF REMOTE CONTROLS .....	24
5.3.1	P8 - 2 lever manual distributor .....	24
5.3.2	E8 - Electric control unit .....	25
<b>6</b>	<b>DISTRIBUTION DEVICES</b> .....	<b>26</b>
6.1	TYPES AND IDENTIFICATION CODES .....	26
6.2	ELBOW FITTINGS FOR THE DISTRIBUTION DEVICES .....	27

<b>7</b>	<b>ACCESSOIRES</b> .....	<b>28</b>
7.1	FILLING PIPING .....	28
7.2	ROTATING GROUP WITH ELECTRIC CONTROL .....	28
7.3	ADDITIONAL AGITATION PUMP .....	28
7.4	MECHANICAL BLADE AGITATOR .....	28
<b>8</b>	<b>FILLING PROCEDURES</b> .....	<b>29</b>
8.1	INTRODUCTION - USE OF THE FAN RELEASE .....	29
8.2	BY INLET .....	30
8.3	WITH FILLING PIPING .....	31
<b>9</b>	<b>MIXTURE AGITATION</b> .....	<b>33</b>
<b>10</b>	<b>DISCHARGE OF THE HYDRAULIC CIRCUIT</b> .....	<b>33</b>
<b>11</b>	<b>SPRAYER ADJUSTMENT</b> .....	<b>34</b>
11.1	BASIC INFORMATION: "LOW VOLUME" .....	34
11.2	DETERMINING THE ADJUSTMENT DATA .....	37
<b>12</b>	<b>PROCEDURES FOR USE</b> .....	<b>48</b>
12.1	OPERATIONS PRIOR TO TREATMENT .....	48
12.2	OPERATIONS IN PREPARATION FOR TREATMENT .....	48
12.3	TREATMENT .....	49
12.4	END OF TREATMENT - STORAGE .....	50
12.4.1	Daily .....	50
12.4.2	End of seasonal cycle .....	50
<b>13</b>	<b>LIFTING AND TRANSPORT</b> .....	<b>51</b>
<b>14</b>	<b>MAINTENANCE OPERATIONS</b> .....	<b>52</b>
14.1	LUBRICATION .....	52
14.2	CLEANING THE DELIVERY FILTER .....	53
14.3	CLEANING THE SUCTION FILTER .....	53
14.4	FAN CLEANING .....	54
14.5	FAN BELT STRETCHER .....	54
14.6	PUMP BELT STRETCHER .....	54
14.7	TABLE OF MAINTENANCE OPERATIONS .....	55
<b>15</b>	<b>TROUBLE SHOOTING</b> .....	<b>56</b>
<b>16</b>	<b>REPAIRS ALLOWED</b> .....	<b>58</b>
16.1	ASSEMBLYING THE PUMP CONTROL BELT .....	58
16.2	REPLACING THE FUSES OF THE ELECTRIC UNIT .....	58
<b>17</b>	<b>INTEGRATIVE DIAGRAMS</b> .....	<b>59</b>
17.1	HYDRO-PNEUMATIC DIAGRAM .....	59
17.2	ELECTRIC CONNECTIONS .....	60
<b>18</b>	<b>NOISE LEVEL</b> .....	<b>61</b>
<b>19</b>	<b>GUARANTEE</b> .....	<b>61</b>
<b>20</b>	<b>ENCLOSED: STATEMENT OF CONFORMITY</b> .....	<b>62</b>

**18 NOISE LEVEL 18**

**L qA:** Observed equivalent average sound level, expressed in dB (A).

Sprayer model	Noise level L qA - dB(A)
BLITZ 45T	92,0 +- 0,2
BLITZ 50T	93,0 +- 0,2
BLITZ 55T	95,4 +- 0,2
BLITZ 55TS	95,4 +- 0,2
BLITZ 55TE	95,4 +- 0,2

UM55T13I

**19 GUARANTEE 19**



**THE OPERATOR IS NOT ALLOWED TO CARRY OUT MODIFICATION ON THE ATOMIZER'S STRUCTURES OR ON ITS OPERATION. THIS WOULD MEAN IMMEDIATE LOSS OF THE EXISTING RIGHTS OF GUARANTEE AND WOULD FREE C.I.M.A. S.P.A. FROM ANY CONSEQUENT RESPONSIBILITY.**

The machines are guaranteed for **12 months** from the date of delivery. During this time, the parts that are not normally subject to wear and that are found defective, will be replaced free of charge, except for transport and workmanship costs.

The guarantee is no longer valid when:

- a. The machine is repaired without the permission of the manufacturer or of one of its service centers.
- b. Non-original spare parts are used.
- c. The machine is used for purposes different from its original intended use.
- d. The instructions contained in this manual and in its accompanying parts have not been complied with.

## 17.2 - ELECTRIC CONNECTIONS

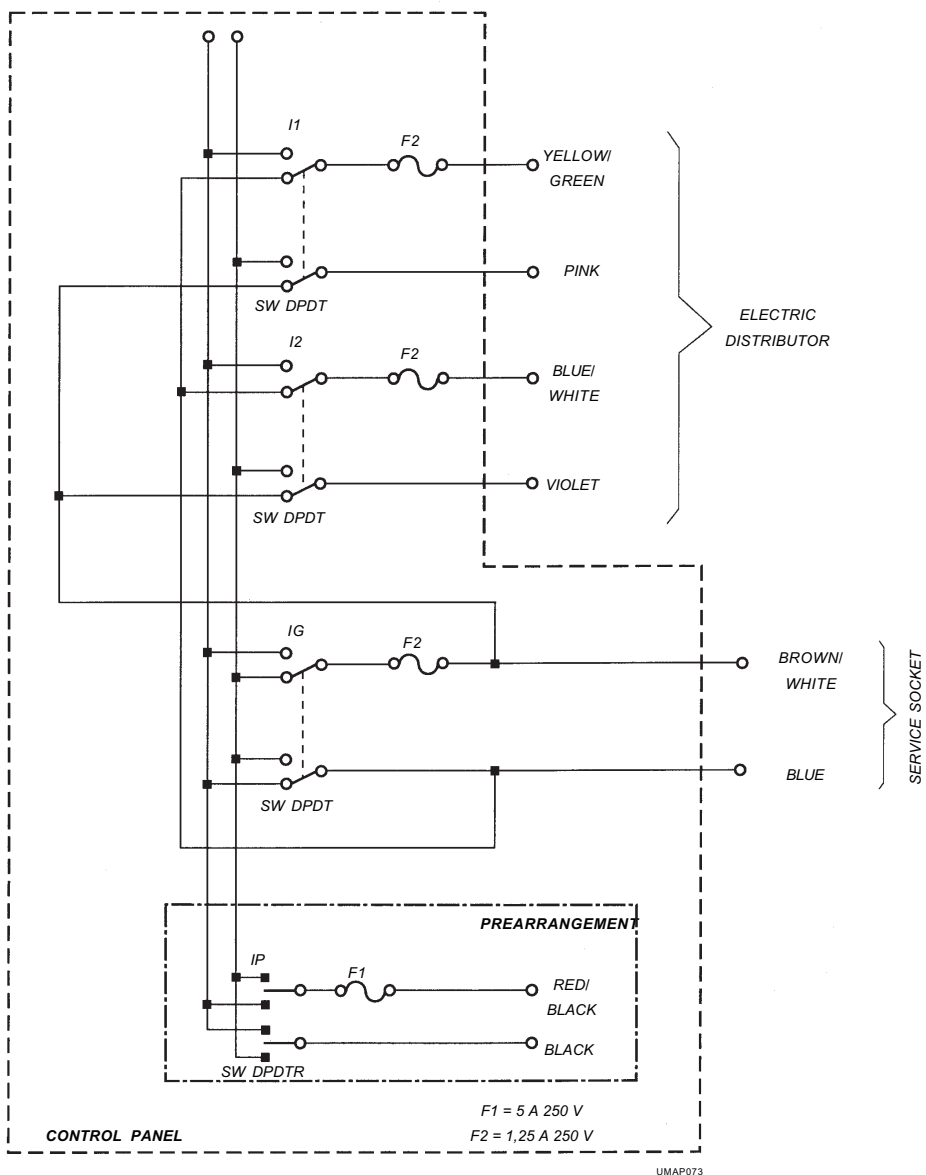

### 1.1 - PUBLICATION IDENTIFICATION

The manual "INSTRUCTIONS FOR USE AND MAINTENANCE" is an official document issued by C.I.M.A. S.p.A. and is considered an additional part of the machine. The manual displays a publication number on the third cover page which allows for identification, tracing and reference.

All of the information contained herein has been accurately checked. C.I.M.A. S.p.A. reserves the right to modify this manual without prior notice and does not take responsibility for any errors and/or omissions.

### 1.2 - PUBLICATIONS ATTACHED

- Spare parts catalogue;
- Instructions for use and maintenance of the distribution devices;
- Catalogue of spare parts for the distribution devices.

### 1.3 - PURPOSE OF THE PUBLICATION

All of the necessary indications for use and maintenance contained in this manual are intended for the utilization of the sprayer. The duration and functionality of the machine, the operator's safety and regard for the environment all depend on the careful observance of the regulations described herein.

Before using the sprayer, the operator should read and adhere to all of the instructions listed in this manual, which are updated through the publication date.

### 1.4 - REFERENCE TO REGULATIONS

This manual was created in conformity with the instructions contained in:

- Enclosure "I" of Instruction 89/392/C and subsequent modifications (letters "b", "c" of point 1.1.2 and point 1.7.4);
- UNI EN 292/2 - 1992, point 5.5.

### 1.5 - USE OF THE MANUAL

Read this manual from the beginning to the end without omitting any pages, paying special attention to the meaning of the warning or danger instructions in the text and indicated by the signs displayed on the machine or on its parts. All of the operations described herein should be carried out with the utmost care and only after you have understood the negative consequences of executing them poorly.

The manual is divided into two parts.

- \* The first part, the pages of which are marked by Roman numerals, consists in:
  - Title page
  - List of valid pages
  - Registration of additions and changes
  - Table of contents

This allows for the identification of the publication and awareness of its level of updating and validity regarding the product. The table of contents allows the user to find the pages concerning the subject he/she is interested in quickly and efficiently.



\* The second part, the pages of which are marked by cardinal numbers, has been developed to give the user the necessary information for working while respecting the safety standards during all of the stages of preparation, use, handling and maintenance of the sprayer.

In the course of the text, we have used some symbols to highlight and visually distinguish the importance of the different kinds of information.

Graphic representation and meaning of the symbols:



It indicates important supplementary information.



It the non observance of the instruction given herein may cause damage to the atomizer which could be irreparable.



Indicates possible situations of danger for persons.

The manual, its enclosures and its possible additions, should be kept with the utmost care and always be complete, integral and legible in all its parts. In case of loss, the owner must immediately ask C.I.M.A. S.p.A. for a duplicate. If the decals originally placed on the machine should become lost, damaged or even partially incomprehensible, they must be replaced without delay.

Each type of head which can be used with the sprayer is delivered complete with a specific manual for use and maintenance. This constitutes an enclosure to this publication. All the head manuals must always come with the machine manual.



- The manual should be kept for the entire life of the sprayer.
- All the amendments received must be kept by inserting them in this publication.
- The manual should come with the sprayer when it is sold.

### 1.6 - UPDATES

The possible updates that C.I.M.A. S.p.A. may send to the owner of the sprayer will be accompanied by the necessary instructions for inserting them in this publication.

If the machine is sold, the owner must ask the buyer to communicate his/her address to C.I.M.A.S.p.A., in order for them to send the possible additions.

### 17.1 - HYDRO-PNEUMATIC DIAGRAM

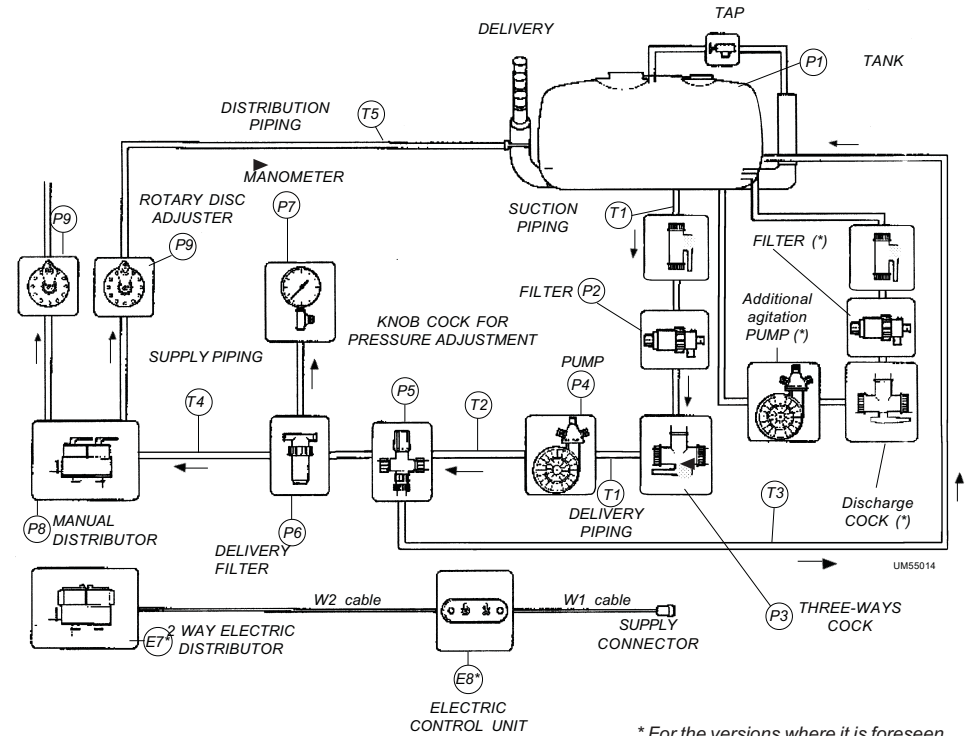



\* For the versions where it is foreseen.

**16 REPAIRS ALLOWED 16**

 **THE OPERATOR IS NOT ALLOWED TO CARRY OUT MODIFICATIONS ON THE ATOMIZER'S STRUCTURES OR IN ITS OPERATION. THIS WOULD MEAN THE IMMEDIATE LOSS OF ALL THE EXISTING RIGHTS OF GUARANTEE AND WOULD FREE C.I.M.A. S.p.A. OF ANY CONSEQUENT RESPONSIBILITY.**

**16.1 - ASSEMBLING THE PUMP CONTROL BELT**

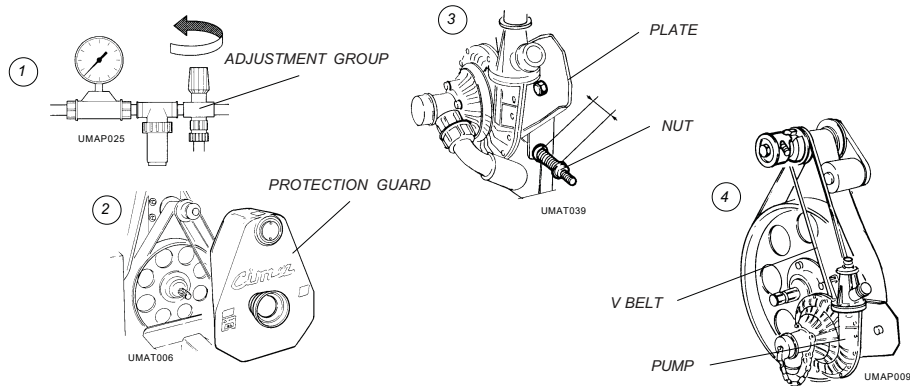

  **Stop the motor and take the ignition key out of the tractor control panel.**

Remove the fan group protection guard by unscrewing the nut fixing it to the frame.  
 Unscrew the belt stretcher spring adjustment nut: the pump supporting plate is now free to rotate.  
 Introduce the belt into the pump pulley race and then into the race of the upper pulley, behind the release.  
 Reset the belt stretcher spring in in the prescribed tension condition.  
 Re-assemble the fan group protection guard.





 **Accurately tighten the screws and the nut used for this operation.**

**16.2. - REPLACING THE FUSES OF THE ELECTRIC UNIT.**

  **Stop the motor and take the ignition key out of the tractor's control panel.**

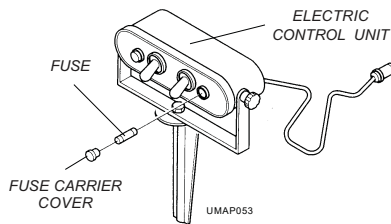
1. Unscrew the fuse holding cover;
  2. Replace the fuse and screw the cover again.
- \* **Fuse: 1,25 A with delay.**



 **ALL OTHER TYPES OF REPAIRS MUST BE CARRIED OUT AT A CIMA S.p.A. AFTER-SALE SERVICE CENTER. C.I.M.A. S.p.A..**

**2 GLOSSARY 2**

**2.1 - TERMINOLOGY**

The terms FRONT, REAR, RIGHT and LEFT used in this publication are referred to the sprayer as seen by an operator standing behind the operative unit and looking at the same; the rear part of the machine is the nearest to the operator, where the head is mounted; the front part is where the sprayer is hitched to the tractor.  
 The "distributing device" can also be called "distribution head".

**2.2 - ABBREVIATIONS**

g	.....	grams
rpm	.....	revolutions per minute
h	.....	hour
ha	.....	hectares
ha/h	.....	hectares per hour
l	.....	litres
l/h	.....	litres per hour
kg	.....	Kilograms
km	.....	Kilometers
km/h	.....	Kilometers per hour
Wm	.....	Width in metres
m	.....	metres
Mesh	.....	No. of meshes per straight inch
Micron	.....	1/1000 of millimeter
PTO	.....	power take-off
s	.....	seconds

**2.3 - SAFETY DECALS**

The machine is provided with decals concerning safety, use and maintenance.

**Safety**

- 1 - 95001 - **STOP THE MOTOR AND TAKE THE KEY OUT OF THE TRACTOR CONTROL PANEL BEFORE CARRYING OUT ANY MAINTENANCE OR REPAIR OPERATION.**
  - Position: on the plastic protection guard of the gearbox group.
- 2 - 95004 - **DANGER: CONTAMINATION DUE TO CONTACT WITH OR INHALATION OF POISONOUS PRODUCTS.**
  - Position: on the main tank, near the loading openings.
- 3 - 95005 - **DANGER: ROTATING COMPONENTS. BEFORE REMOVING THE PROTECTIVE DEVICES, STOP THE TRACTOR, TAKE THE KEY OUT OF THE CONTROL PANEL AND MAKE SURE THAT ALL COMPONENTS HAVE STOPPED.**
  - Position: on the tank, front part of the machine, near the fan guard.
- 4 - 95008 - **MACHINE WITHOUT ADDITIONAL TANK FOR PERSONAL CLEANING.**
  - This decal is placed under the hand-wash tank when this is not mounted.

- 5 - 95015 - **BEFORE USING THE RELEASE, STOP THE TRACTOR TAKE THE KEY OUT OF THE CONTROL PANEL AND MAKE SURE THAT THE FAN HAS STOPPED.**
  - Position: on the cover of the gearbox protection guard.
- 6 - 95010 - **MAXIMUM WORKING SPEED OF THE POWER TAKE-OFF: 540 RPM.**
  - Position: near the power take-off (PTO).
- 7 - 95007 - **DANGER: SPRAYS. REMAIN AT A SAFE DISTANCE.**
  - Position: on the frame rear, left part.
- 8 - 95006 - **ATTENTION: CONSULT THE USE AND MAINTENANCE MANUAL BEFORE USE OR WORK ON THE MACHINE.**
  - Position: in the front part of the machine, on the tank's hood.
- 9 - 95009 - **DANGER: USE PROTECTIVE GLOVES WHILE EMPTYING THE TANK.**
  - Position: on the machine's left-hand side, near the three-way tap.
- 9\* - 95009 - **DANGER: USE PROTECTIVE GLOVES WHILE EMPTYING THE TANK.**
  - Position: on the machine's left-hand side, near the three-way tap.
- 10 - 95055 - **ATTENTION: THE MACHINE IS NOT APPROVED FOR DRIVING ON THE ROAD.**
  - Position: on the left-hand part of the tank front..
- 11 - 95059 - **3 HOOKING POINTS FOR LIFTING THE MACHINE**
  - 2 points are located on the lateral guards in the front part of the machine, and 1 is on the rear bracket for fastening the distribution devices.

### Use and maintenance

- 12 - 95052 - **GREASE EVERY 20 HOURS: FAN SHAFT BEARINGS**
  - Position: on the frame, front left part.
- 13 - 95053 - **GREASE EVERY 50 HOURS: FAN BELT STRETCHER SUPPORT**
  - Position: on the frame, front left part.
- 14 - 95054 - **GREASE EVERY 200 HOURS:**
  - 1-FREEWHEEL - position: on the front part, near the PTO protection guard.
  - 2-BEARING FOOT - position: under the adjustment crank.
  - 3-WHEEL HUBS - position: on the hubs.
- 15 - 95067 - **OIL EVERY 50 HOURS: PUMP BEARINGS.**
  - Position: On the left-hand side of the multiplier unit protection guard, near the pump.
- 15\* - 95067 - **OIL EVERY 50 HOURS: PUMP BEARINGS.**
  - Position: On the right-hand side of the multiplier unit protection guard, near the pump.
- 16 - 95057 - **HANDWASH TANK TAP**
  - Position: on the handwash tank, left-hand side.
- 17 - 95065 - **ATTENTION: NEVER LET THE ATOMIZER RUN WITHOUT LIQUID INSIDE THE TANK**
  - Position: left-hand side of the tank.
- 18 - 95063 - **INSTRUCTIONS FOR USE AND MAINTENANCE OF THE ELECTROVALVES**
  - Position: on the rear right-hand side of the frame.
- 19 - 95060 - **WHEEL OPERATING PRESSURE**
  - 95056 - Position: on the tank's sides above the wheels. See appropriate Table at point 4.5.2.
- 20 - 95070 - **OPERATION OF THE THREE-WAY VALVE**
  - Position: left-hand side, near the valve.
- 21 - 95071 - **OPERATION OF THE THREE-WAY VALVE**
  - Position: right-hand side, near the valve of the additional pump.



THE 5-FIGURE NUMBERS ARE THE CODES TO BE USED FOR ORDERING DECALS.

## E. PROBLEM: Abnormal and constant noise with vibration of the fan group

- 1. CAUSE Breakage of the fan' shaft bearings.  
**REMEDY:** Refer to C.I.M.A. after-sale service.

## F. PROBLEM: Intermittent delivery of the whole distribution device

- 1. CAUSE Seal leak in that part of hydraulic circuit going from the tank's suction piping (T1) to the manual (P8) or electric (E7) distributor.  
**REMEDY:** Carefully check all points where air suction may occur, included those where liquid leakage does not appear.  
Check functionality of the pump and its belt. Check tightening of ring nuts, unions and clamps. Verify the efficiency of gaskets and the integrity of pipings. Reset the efficiency and replace the possible faulty parts.

## G. PROBLEM: Intermittent delivery from on side only of the distribution device

- 1. CAUSE Seal leak of seal in that part of the hydraulic circuit going from the manual (P8) or electric (E7) distributor to the involved distribution point.  
**REMEDY:** As per point F.1.

## H. PROBLEM: Non-delivery of powders: complete or from one side only of the distribution device

- 1. CAUSE The cocks of the manual distributor (P8) are dirty or clogged.  
**REMEDY:** Clean them.
- 1b.CAUSE The cocks of the electric distributor (E7) are blocked by scaling in the closing position.  
**REMEDY:** Clean them with clean water.
- 2b.CAUSE The fuses of the electric control unit are blown when the cocks of the electric distributor (E7) are closed.  
**REMEDY:** Replace the fuses.
- 3b.CAUSE Incorrect connection of the W1 supply cable of the electric control unit to the cocks of E7 electric distributor E7 in closing position.  
**REMEDY:** Connect it correctly.
- 4b.CAUSE Faulty electric connections.  
**REMEDY:** Refer to C.I.M.A. after-sale service.
- 5. CAUSE Faulty pump (only in case of complete non-delivery).  
**REMEDY:** As per point "B".
- 6. CAUSE Broken pump belt.  
**REMEDY:** Replace the belt.



THE CAUSES AND REMEDIES FOR PROBLEMS IN DELIVERY OF POWDERS FROM ONE OR MORE SPRAYERS ARE DETAILED IN THE USE AND MAINTENANCE MANUAL OF EACH DISTRIBUTION DEVICE.

**15 TROUBLE SHOOTING 15**

**A. PROBLEM: When using the filling piping the pump does not intake**

1. CAUSE The quantity of water poured into the tank is not enough to prime the pump.  
**REMEDY:** Add water to the tank until the pump begins to recycle.
2. CAUSE The foot valve takes air in.  
**REMEDY:** Fully immerse the foot valve.
3. CAUSE Lack of seal of the hydraulic circuit.  
**REMEDY:** Check tightening of ring nuts, unions and clamps. Verify the efficiency of gaskets and the integrity of pipings. restore working order and replace all possible faulty parts.
4. CAUSE Slippage of the pump belt.  
**REMEDY:** Check the tension of the belt stretcher spring.
5. CAUSE Breakage of the pump belt.  
**REMEDY:** Replace the belt.

**B. PROBLEM: Leakages and drippings from the pump**

1. CAUSE Leak of seal in unions and clamps connecting the pipings to the pump.  
**REMEDY:** Check tightening of ring nuts and clamps. Verify the efficiency of gasket. Replace the possible faulty parts.
2. CAUSE Leak of seal (O-ring) of the outside pump coupling flanges.  
**REMEDY:** Refer to C.I.M.A. after-sale service.
3. CAUSE Breakage of mechanic seal.  
**REMEDY:** Refer to C.I.M.A. after-sale service.

**C. PROBLEM: Hydraulic circuit pressure drop signalled by the manometer**

1. CAUSE Delivery or suction filter are dirty.  
**REMEDY:** Clean the cartridge.
2. CAUSE Lack of seal in the hydraulic circuit.  
**REMEDY:** Check functionality of the pump and its belt. Check tightening of ring nuts, unions and clamps. Verify the efficiency of gaskets and the integrity of pipings. Restore working order and replace the possible faulty parts.
3. CAUSE Faulty centrifugal pump. See point "B".  
**REMEDY:** As in point "B".
4. CAUSE Faulty manometer.  
**REMEDY:** Refer to C.I.M.A. after-sale service.

**D. PROBLEM: Vibration of the fan group**

1. CAUSE The fan is dirty.  
**REMEDY:** Refer to C.I.M.A. after-sale service for cleaning.
2. CAUSE The 2 PTOs are not aligned or are not parallel.  
**REMEDY:** Position the 2 PTOs in the correct way.

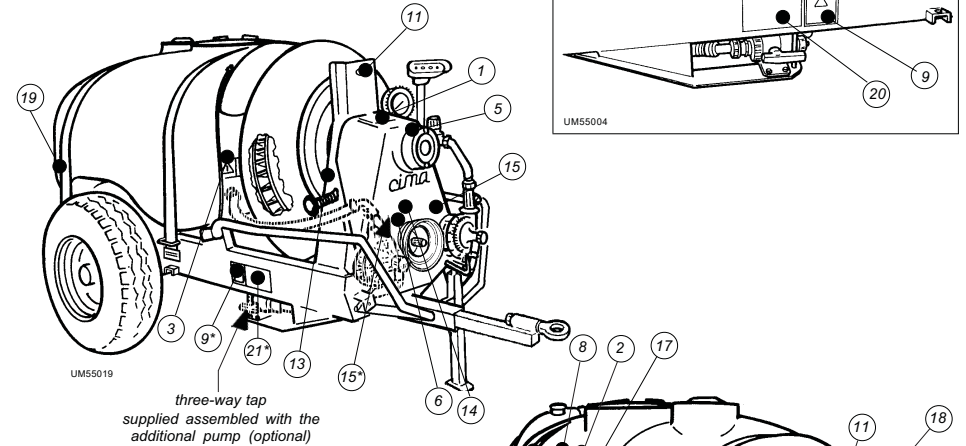
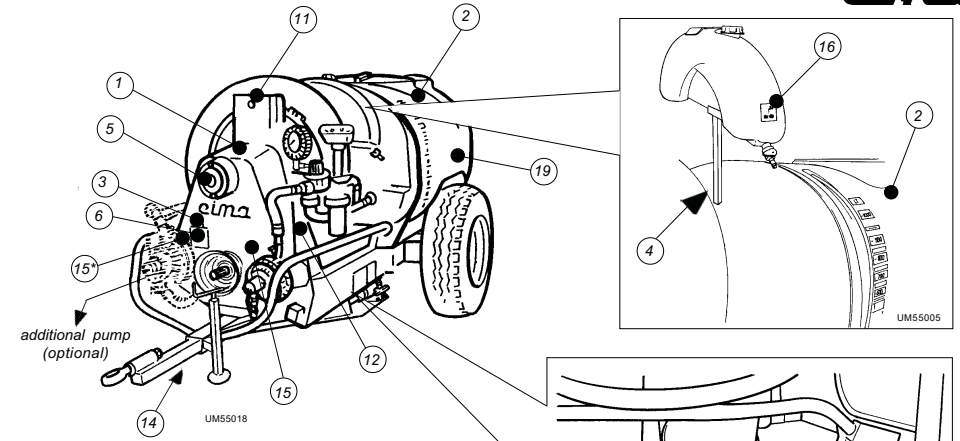

**NOTE:** The numbers with asterisk indicates the decals to be used with the additional agitation pump.

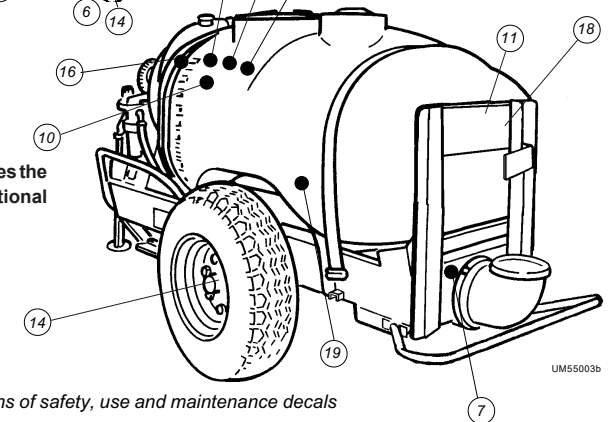

Positions of safety, use and maintenance decals

\* Safety

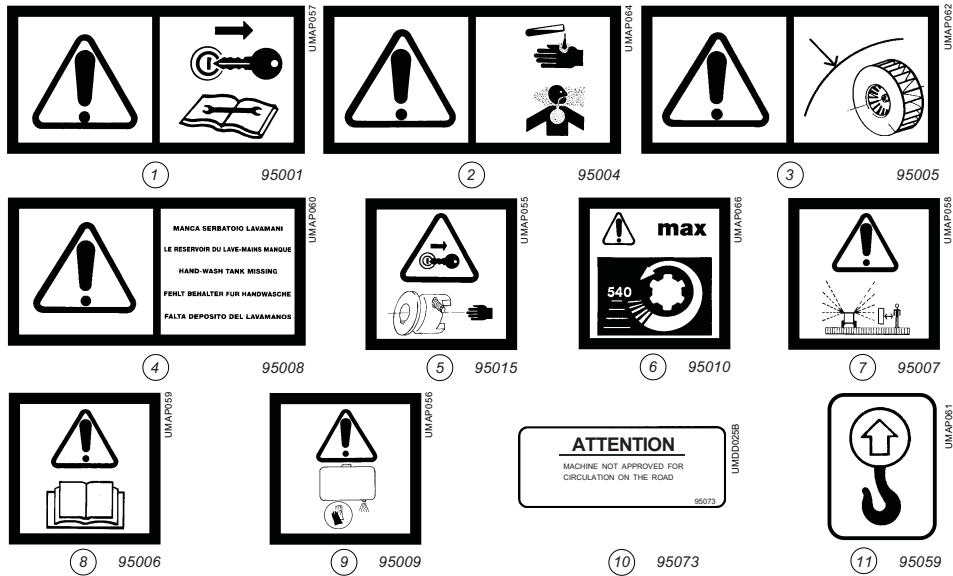

\* Use and maintenance

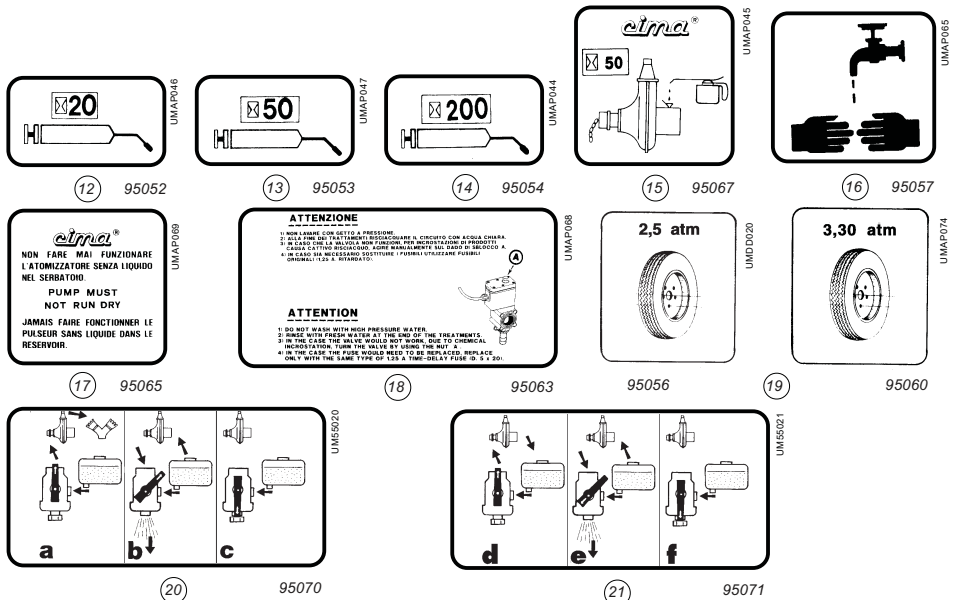

14.7 TABLE OF MAINTENANCE OPERATIONS

CHECK	AT THE BEGINNING OF TREATMENT'S SEASON	BEFORE EACH TREATMENT	AFTER EACH TREATMENT	END OF TREATMENT'S SEASON	RATE RECCOMENDED
Fan belt stretcher spring: CHECK LENGTH 9-12 cm.	YES	YES	**	**	**
Pump belt stretcher spring: CHECK LENGTH 4-5 cm.	YES	YES	**	**	**
Fan support and low support: GREASE.	YES	**	**	YES	20 h
Fan belt stretcher support: GREASE.	YES	**	**	YES	50 h
Pump bearing: OIL.	YES	**	**	YES	50 h
Wheels bearing: GREASE.	YES	**	**	YES	**
Bearing foot: GREASE.	YES	**	**	YES	**
Free wheel: GREASE.	YES	**	**	YES	**
Rudder: GREASE.	YES	**	**	YES	**
Couplings and pipings: CHECK THEIR INTEGRITY.	YES	YES	**	**	**
Clamps and unions: CHECK TIGHTENING.	YES	YES	**	SI	**
Suction filter: CHECK CLEALINESS.	**	YES	YES	YES	**
Delivery filter: CHECK CLEANLINESS.	**	YES	YES	YES	**
Hydraulic circuit and tank: WASH.	**	**	YES	YES	**
Hydraulic circuit and tank: CLEAN AND COMPLETELY EMPTY.	**	**	**	YES	**
Calibrated holes adjustment disk: CLEAN.	**	YES	YES	YES	**
Tyres pressure: CHECK.	**	YES	**	**	**
Sprayer: CHECK.	**	**	YES	YES	**
Sprayer: STORE.	**	**	**	YES	**

### 14.4 - FAN CLEANING



DIRT DEPOSITS OR SCALING MAY UNBALANCE THE FAN AND CAUSE VIBRATIONS. CLEANING MUST BE CARRIED OUT AT A C.I.M.A. AFTER-SALE SERVICE CENTER.

### 14.5 - FAN BELT STRETCHER

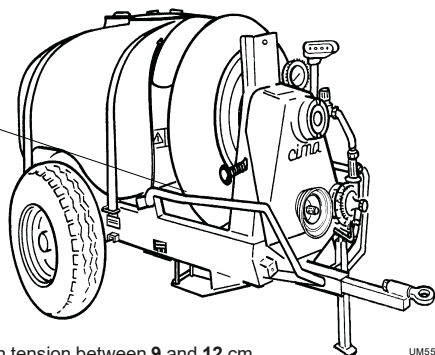
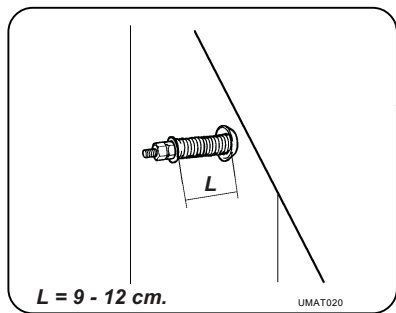

Check the length "L" of the spring (see picture): it must be in tension between **9** and **12** cm.

UM55002

### 14.6 - PUMP BELT STRETCHER

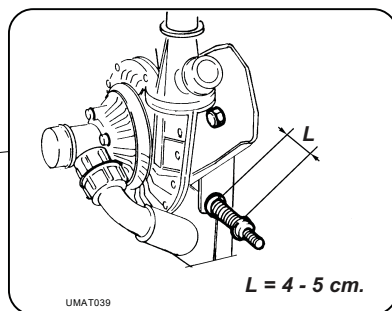
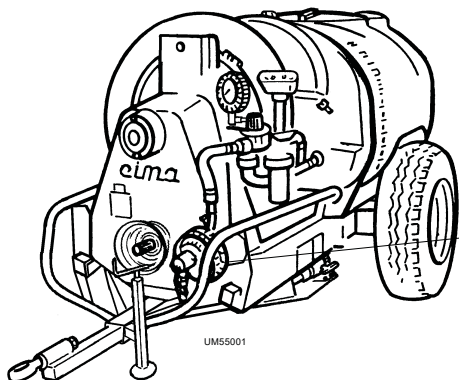

Check the length "L" of the spring (see picture): it must be in tension between **4** and **5** cm.

### 3.1 - IDENTIFICATION OF THE MACHINE



UMAP001

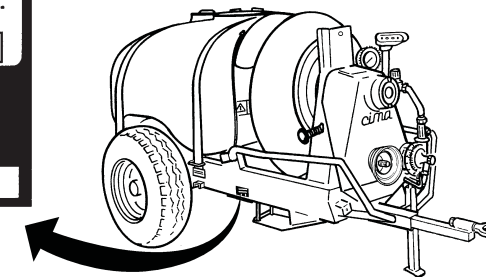

UM55006

Identification nameplate

### 3.2 - TECHNICAL ASSISTANCE

C.I.M.A. S.p.A. is at its customers' full disposal for any kind of assistance. The names and addresses of its assistance centers, in Italy and abroad, may be requested at:

C.I.M.A. S.p.A. - via Sicilia 2 - 27047 S. MARIA DELLA VERSA (PV) - ITALIA  
 Tel.: 0385-278223 - Fax: 0385-798184  
 from abroad: Tel.: \*\*39-385-278223 - Fax: \*\*39-385-798184

### 3.3 - SAFETY WARNINGS

All the preparation, use, maintenance, handling and transport operations should be carried out only after you have acquired perfect understanding of all instructions contained in this publication and the ability to interpret in the correct way the symbols applied on the machine.



IT IS NOT PERMITTED TO USE THE SPRAYER FOR PURPOSES OTHER THAN ITS ORIGINAL USE, AS IT HAS BEEN DEVELOPED EXCLUSIVELY FOR DISTRIBUTING INSECTICIDES ON AGRICULTURAL CULTIVATIONS.

The following general rules must be respected scrupulously:

- always stop the motor before carrying out any operation on the sprayer;
  - check that the weight and power of the tractor are compatible with the sprayer to be used;
  - before use, check the different components of the machine for correct tightness and fastening, paying special attention to the safety protection devices and the running parts;
  - only use U-joints with protection devices accompanied by EC statement of conformity.
- Carry out the coupling only if the power take-off of the tractor and sprayer is equipped with a counter guard;
- check that the protection device of the U-joint is fastened with the appropriate anti-rotation chains;
  - clear people and animals away from the machine before starting it;
  - do not wear clothes that could get caught in the running parts of the machine;

— reduce the speed when going over dips in the road or crossing ditches.



- All the maintenance and repair operations should be carried out only after having carefully cleaned the hydraulic circuit with clean water.
- Before operating in the tank it is necessary to carefully wash it inside with clean water.
- It is forbidden to weld if ammonium salts have been used.
- It is forbidden to use the machine in a potentially explosive atmosphere.
- It is not permitted to spray paints and/or solvents, to wash areas and/or machinery or to utilize the air stream for purposes different from the distribution of agrochemicals.

### 3.4 - SAFETY DEVICES

All running parts of the machine are adequately protected and indicated by warning decals.



- It is forbidden to use the machine if the protection devices have been removed.
- Before lifting the tank lid or removing the protection devices, stop the motor of the tractor and take the key out of the control panel.
- Before beginning the distribution of the product, make sure that the lid is closed.

The picture shows the protected parts of the machine:

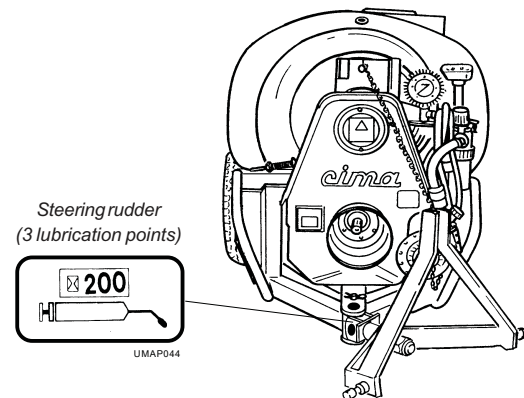
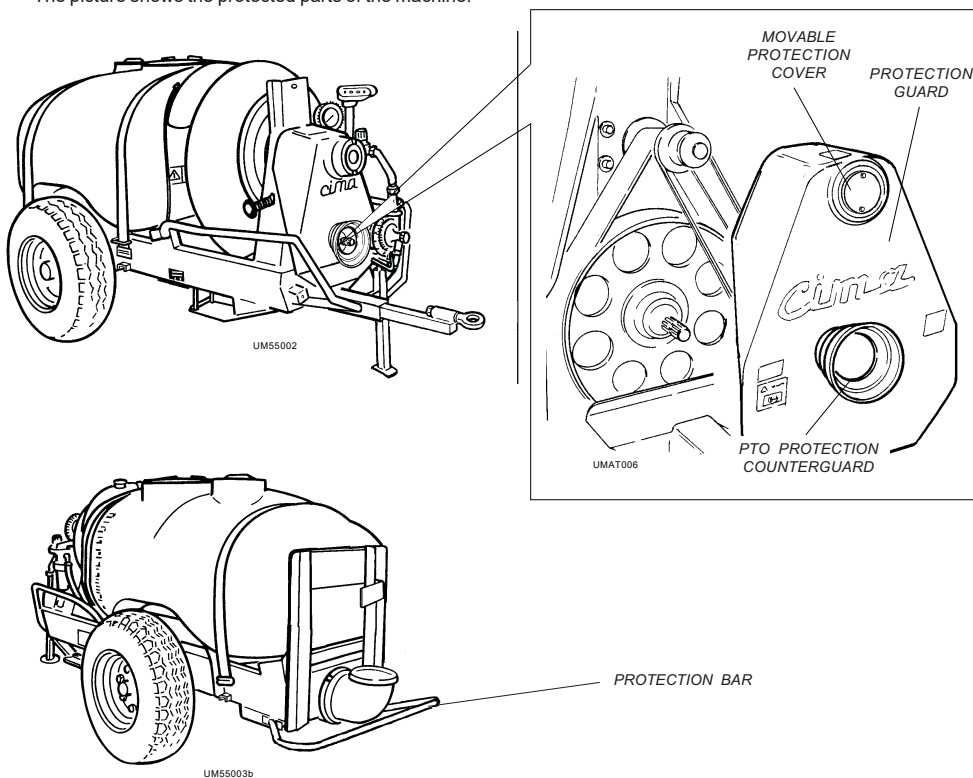

### 14.2 - CLEANING THE DELIVERY FILTER

1. Bring the lever of the P3 3-ways tap to position "C".
2. Close the P5 knob-cock.
3. Close the cocks of the P8 manual distributor or E7 electric distributor.
4. Loosen the ring nut and remove the cover.
5. Extract the cartridge: clean the net and the sealing O-rings.
6. Introduce the cartridge again and fix the cover by means of the ring nut. Pay attention to the cover O-ring during assembly: a lack in filter seal will compromise the performance of the distribution devices.

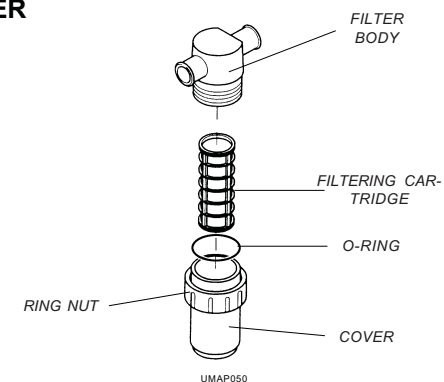

### 14.3 - CLEANING THE SUCTION FILTER

The filter service cock permits operating even if the tank contains the mixture.

1. From the work position, shut the P2 cock filter by turning the lever 90°.
2. Bring the P3 3 ways cock lever to the "c" position.
3. Shut the P5 handgrip cock.
4. Shut the cock of the distributor (P8 if manual or E7 if electric)
5. Unscrew the ring nut and remove the cartridge.
6. Extract the cartridge: clean the net and the O-rings.
7. Bring the lever of the P3 3 way tap to the "a" position and re-open the filter cock by bringing the lever to the working position.

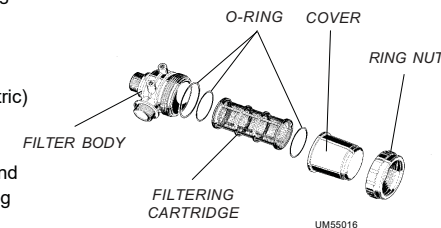

14 MAINTENANCE OPERATIONS 14

 ALL THE OPERATIONS SHOULD BE CARRIED OUT WHEN THE MOTOR IS OFF AND THE IGNITION KEY IS OUT OF THE CONTROL PANEL.

14.1 - LUBRICATION

Parts to be lubricated	action	Material to be used	Periods
Fan shaft bearing support	Grease	Grease type EP Class NLGI 2	20 h
Fan belt tensioner support	Grease	Grease type EP Class NLGI 2	50 h
Pump bearing	Lubricate	Engine oil	50 h
Free wheel	Grease	Grease type EP Class NLGI 2	200 h
Wheel hub	Grease	Grease type EP Class NLGI 2	200 h
Bearing foot	Grease	Grease type EP Class NLGI 2	200 h

UMATT11

-  • Accurately clean the grease nipples and the air inlet to avoid introducing dirt during lubrication.  
 • In case of intensive use of the machine, decrease the lubrication time intervals.

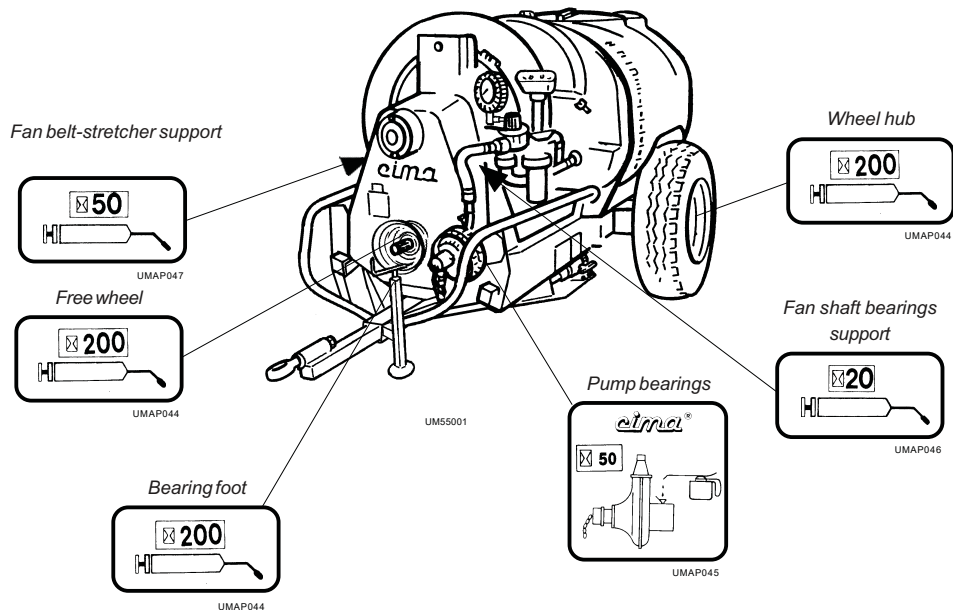

3.5 - HANDLING OF AGROCHEMICAL PRODUCTS

The operator may be contaminated either by contact with or inhalation of the products and mixtures to be distributed. The environment may be polluted by the spillage of the products, the careless conservation of empty or unwashed packages, and by pouring the products into the water system.

To avoid these risks, the filling operations should be carried out in suitably prepared and adequately equipped areas, or on the treatment site.



3.5.1 - Storage

**Permanent/Stationary:** the room used should be ventilated and provided with locking doors to prevent the accidental entry of children and unskilled persons.

**Mobile:** this means of storage should have a lock, to prevent children and unskilled persons from opening it in the absence of the operator. All containers, either full or partially empty, must be placed in a way so as not to tip over, fall or break during transport.

Both types of storage should:

- have an appropriate container for storing the empty packages, if a special area is not available;
- have access to clean water for washing, by way of a container or connection to the water supply;
- have access to fire-extinguishers in the presence of inflammables.

-  - All containers, either full or partially empty, should be kept in their original packaging and their labels should always be legible.  
 - The instructions for storage, use and disposal which are displayed on the original packaging of the products should always be scrupulously respected.



3.5.2 - Specific equipment

The preparation or filling area must provide:

- all the equipment necessary for measuring the exact quantity of water and of the product to be poured into the tank at each filling;
- all the necessary equipment and tools for preparing the mixture and cleaning the operator in case of contamination;
- all equipment for the easy direct introduction of agrochemical products into the tank;
- a supply of clothes and preventive measures to avoid contamination either by contact or inhalation during the operative stage of the intervention;
- the appropriate equipment for stopping spillage and overflow of the mixture without control;
- a non-return valve on the supply pipe, when the tank is filled with water running directly from the water supply.

3.5.3 - Disposal of empty containers and agrochemical residue

Agrochemicals are classified as "special" waste and their disposal must be different from "urban" waste.

-  The empty packages and the contaminated containers to be disposed of should not be abandoned, burnt or buried in the ground.  
 The water used for washing the tanks and the equipment used for preparing the mixtures must not be drained onto the ground or poured into channels, streams or rivers.



The disposal of special waste is regulated by specific norms. To carry out the operation, it is necessary to obtain the appropriate information at the competent local offices. The non-observance of these laws may cause enormous damages to people, animals and the environment.

### 3.5.4 - Personal protection means

The toxicity of agrochemicals compels people using them to wear adequate protective clothing and accessories to avoid the risks of contamination by contact or inhalation.

#### The operators must wear:

- Polyethylene or polyvinyl gloves.
- Full body overalls in waterproof cotton, to allow perspiration with side polypropylene coatings. It is possible to find disposable tyvek overalls that, after use (see picture), must be disposed of in the same way as the toxic waste.
- Half-size mask in neoprene rubber with 1 or 2 filters. It is possible to use filters for gas and organic vapors (European class A1) combined with filters against powder (European class P1), for mists and irritating powders, or P2 for mists and harmful or toxic powders.

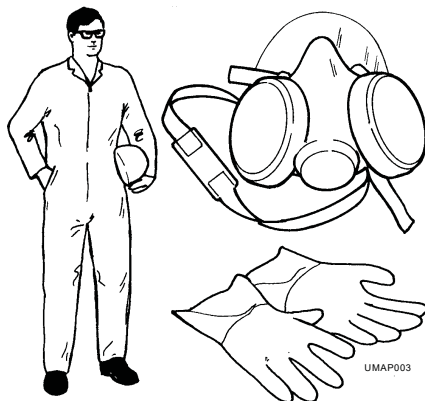

#### The filters should be replaced:

- when you notice odor/taste of agrochemicals, for class A1 with activated carbon;
- when you feel resistance in the breathing functions, for classes P1 and P2 against powders.

It is, however, necessary to use all personal protection means according to the recommendations of the manufacturer.



**ALL TRAILER-MOUNTED SPRAYER ARE NOT APPROVED FOR CIRCULATING ON THE ROAD.**

#### IT IS FORBIDDEN:

- To transport or lift the sprayer with mixture residues in the tank for purposes different from its original use.
- To transport people, animals or objects.
- To tow vehicles or equipment.
- To tow the sprayer on the road.



Transport on the road must be carried out respecting the laws of the traffic code valid in the country where the machine is used. The operator will be held responsible for non-observance of these laws.

#### • Lifting and transport of the sprayer



Before carrying out any operation it is essential to check that there are no mixture residues left in the tank.

1. Check that the cables or the chains are adequate for the weight to be lifted (machine - distribution devices - accessories).
2. Hook the machine up in the supporting points indicated on the frame by decals, and check the tightness of all parts involved in the operation.
3. Lift the machine making sure it is balanced.

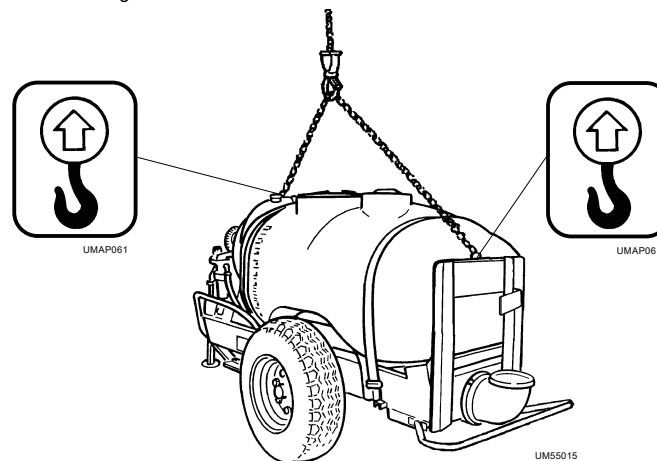

4. Place the sprayer on the means of transport in perfectly stable conditions.
5. During transport the machine must be locked and fastened to the means of transport by an appropriate harness.

e. Immediately wash all elements contaminated during the treatment, promptly take off the contaminated protection clothes and **discontinue the job if these cannot be replaced.**

f.  **Immediately clean the clogged jets.**  
**Avoid using hard and sharpened tools in presence of calibrated holes.**

g. If wind increases, follow the instructions given in the preliminary operations (12.1.c).

h. During the pauses, stop the water and take the key out of the control panel.

i. Pay special attention to treatments near property boundaries, houses, waterways, roads or public paths.

## 12.4 - END OF TREATMENT - STORAGE

### 12.4.1 - Daily

The operator must:

a. Wash the machine externally before cleaning the circuit. The sequence of operations will allow possible residues of water to be eliminated from the ventilating guard and from the pipings which bring the air flow to the heads. These operations must be done in a place where the waste water may be collected in a disposal pit.

b. Clean the hydraulic circuit, washing the interior of the tank with a jet of clean water then spraying the same on the field where treatment was done. If necessary, repeat this operation.

c. Check the efficiency of the distribution device (spray head) and the cleanliness of the pulverization points (diffusers), replacing them if they are damaged or in bad condition.



**The cleaning of calibrated holes must not be done with hard or sharpened tools.**

d. Put the machine in a ventilated place, sheltered from rain and sun; the rays of the sun are the worst enemies of plastic and rubber parts.

### 12.4.2 - End of seasonal cycle

The operator must:

a. Carry out most accurately the operations described at the end of daily treatments; the hydraulic circuit cleaning must be done at least twice. Check that in no part of the circuit there is product residue.

b. Completely empty the hydraulic circuit, paying special attention to the centrifugal pump.



**Avoid using antifreeze solutions.**

c. Check the functionality of the components and structures of the machine. In case of negative results, ask for the intervention of one of our after-sale service centers.

d. Put the machine in a ventilated place, sheltered from rain, ice and rays of sun.



**The use of detergent products for cleaning is allowed only following the norms in force. In merit, the operator should get the necessary information from the competent authorities.**

## 4 STRUCTURAL ANALYSIS OF THE MACHINE 4

The pictures show the position of the main components of the sprayer.

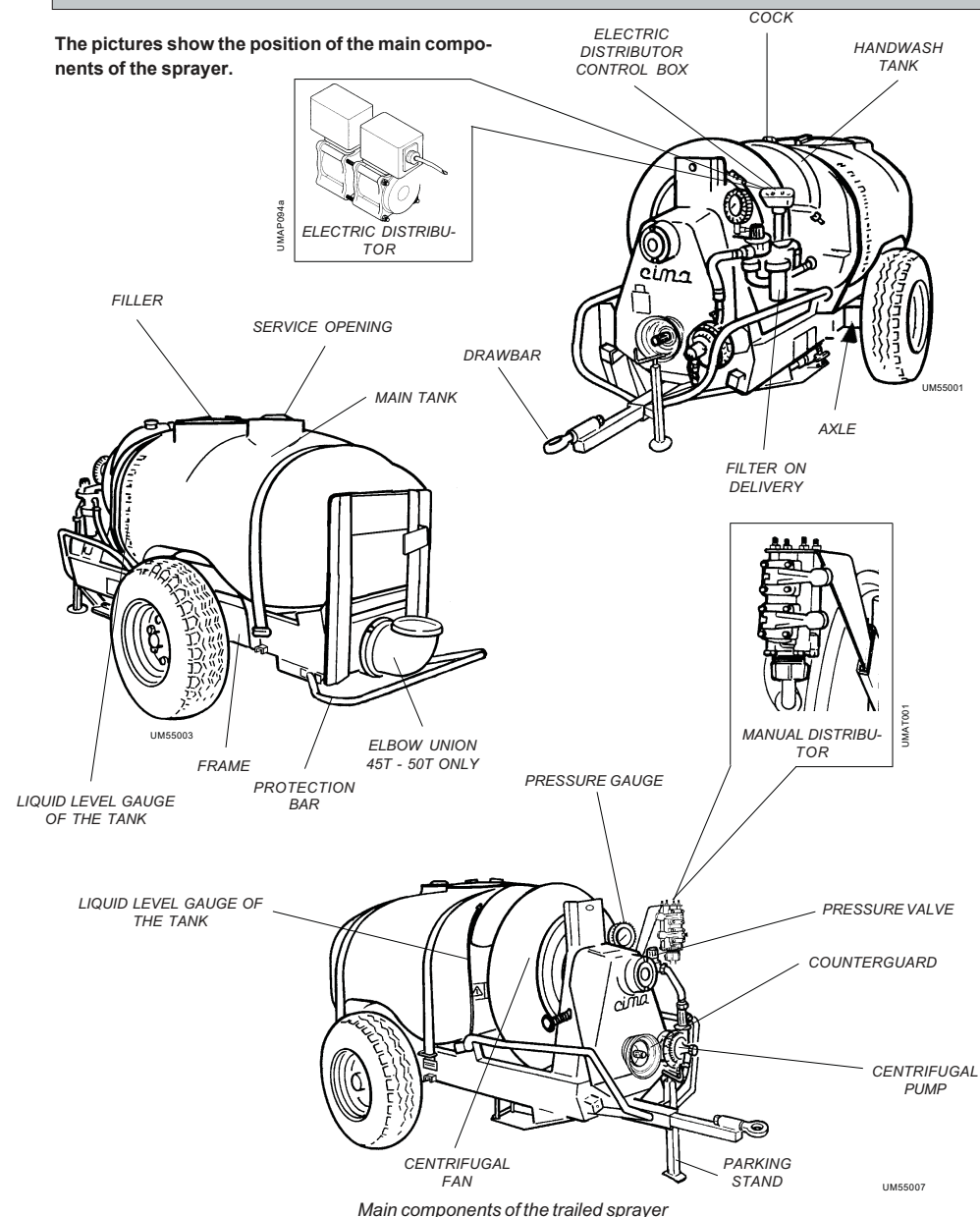

### 4.1 DRAWBAR

**STANDARD DRAWBAR.** It is inserted in the frame front part and is fixed by a through bolt with locking plate and self-drawbar.

- It is adjustable in **height**: 12 cm for the trailer mounted atomizers up to 1000 lt and 16 cm for the 1500-2000 ones.
- It is adjustable in **length** 8 and 16 cm. for the frames up to 1000 lt and 8-16-24 cm. on the 1500-2000 lt ones.

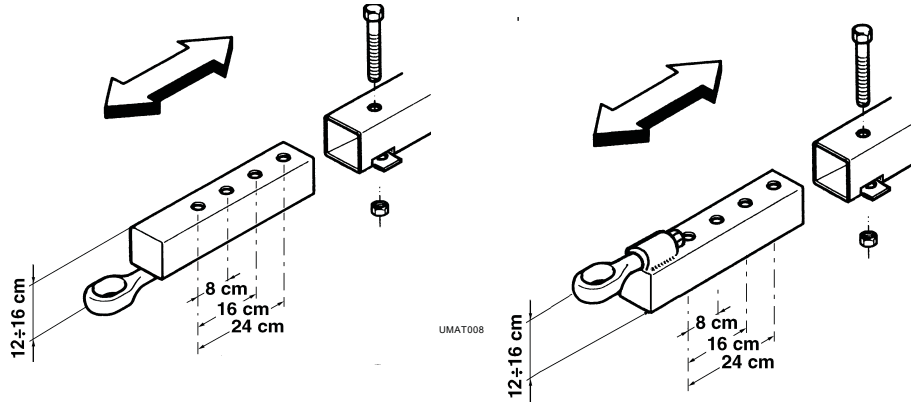

**AXLE.** The axle shafts, inserted in the frame axle and locked by appropriate screws, allow to adjust the **track width**, adapting it to the operation requirements.

- The height from the ground is adjustable. The offset between the axle shaft and the wheels hub allow a variation of 12 cm. It is enough to turn the axle shafts.

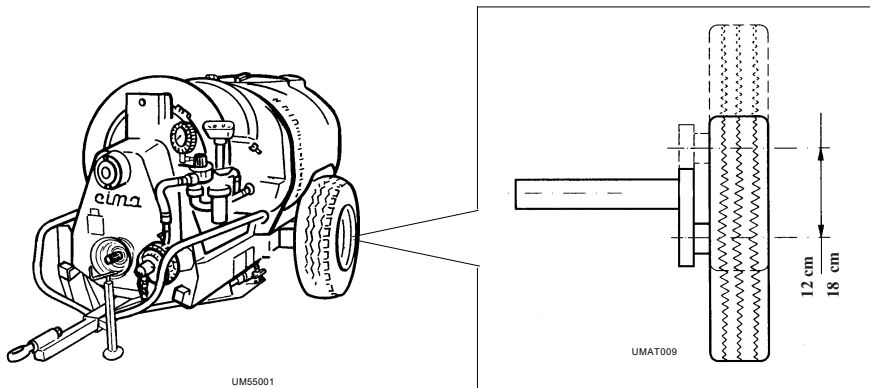

After each adjustment, carefully tighten the screws and the nuts involved in the operation.

- c. Adjust the sprayer according to the parameters calculated during the preliminary operations.
- d. Prepare the mixtures in a well-ventilated place. If this is done outdoors, the presence of wind increases the danger of contamination.
- e. Exactly weigh the previously calculated quantity of product to be mixed at each loading.
- f. Avoid proximity of open flames, live coal or incandescent objects with flammable products.
- g. In case of mixtures with agrochemical products and fertilizers, to have a correct batching of volume, first dilute the fertilizer.
- h. Wash and rinse the emptied product packages with clean water; collect the water used and pour it into the tank before filling; put the packages in the appropriate container or in the storage room.
- i. Wash the equipment and the tools used for preparation and keep them in the storage area for chemical products.
- l. **Always** leave the product loading and preparation area in conditions which will not cause **any** contamination to persons or animals, and environmental pollution.
- m. After you have loaded the machine, fill the tank for personal cleaning with clean water.
- n. If necessary, mark the field or the machine passage area, to provide a guide for treatment and to avoid missing parts or overlapping layers.



- **AT THE END OF THE OPERATION NECESSARY FOR TREATMENT, THE STORAGE-CONSERVATION AREAS MUST BE LEFT IN THE CONDITIONS REQUESTED IN ORDER TO PERFORM THEIR PREVENTIVE AND PROTECTIVE FUNCTIONS.**
- **BEFORE RE-STARTING THE TRACTOR, CLEAR PEOPLE AND ANIMALS AWAY AND NEVER LEAVE THE MACHINE UNATTENDED DURING THE PREPARATION OPERATIONS.**

### 12.3 - TREATMENT



IT IS ADVISABLE TO BEGIN THE TREATMENT AT THE EDGE OF THE FIELD.

#### • The operator must:

- a. Prior to treatment, agitate the mixture in the tank, by RECYCLING its volume for the time necessary to make it homogeneous.
- b. Stop treatment from time to time, agitate the mixture then re-start treatment. If the re-start is delayed, before beginning check the filter cleanliness and agitate the mixture left in the tank.
- c. After each filling, make sure that the additional hand-wash tank is full of clean water.
- d. Use personal protection identical to those advised for the mixture preparation if the tractor is not equipped with a pressurized cab with aeration filters.

**12 PROCEDURES FOR USE 12**

**12.1 - OPERATIONS PRIOR TO TREATMENT**

**• The operator must:**

- a. Make sure that the conditions, the disease stage or the precautionary measures justify the treatment.
- b. Be aware of the weather-forecast for the period of time necessary to carry out the treatment.
- c. If possible, avoid distributing in windy conditions or when mixture begins drifting out of its intended range. It is recommended treatment to be stopped when the wind speed exceeds 3m/sec. (10km/h). In case it is absolutely necessary to carry out the treatment, it is recommended:
  - the distance between the spraying points and the cultivation to be reduced, even if this means having a lower pulverization quality;
  - the drop size to be increased, adjusting the machine accordingly.
- d. Check that the mixtures of different products are compatible from a physical, chemical and biological viewpoint; if necessary ask the retailer for information.
- e. Calculate the exact quantity of product needed for treatment and the volume of water to be employed.
- f. Check that a sufficient quantity of product for the whole treatment is available.
- g. Carefully read the instructions for the use of the product, to check the conditions for use, the correct batching and the expiration dates.
- h. Calculate the necessary parameters for adjusting the machine and determine the exact quantity of product to be used for each loading.  
See instructions at par. 11.2 and those on the use and maintenance manual of the distribution device.

**12.2 - OPERATIONS IN PREPARATION FOR TREATMENT**



**THE LOADING SHOULD BE DONE WITH THE MACHINE ON A FLAT SURFACE. THE QUANTITIES OR THE MIXTURES TO BE POURED INTO THE TANK SHOULD BE PREPARED ON TREATMENT SITE, BEFORE THE OPERATION.**

**• The operator must:**

- a. Wear adequately protective clothes and accessories, to avoid contamination either by inhalation or by contact with the products used, such as overalls, waterproof jackets, gloves, glasses and masks.



- Powder masks do not offer any protection against toxic vapors.
- Avoid using clothes that could get caught in the moving parts.

- b. Check the filter cleanliness and carry out all checking and maintenance operations necessary for setting up the machine.

**WHEELS.** The wheels hubs are equipped with grease nipples for bearing lubrication (see 14.1). The tyres size and the operating pressure are given in point 4.5.2.

**PARKING STAND** with crank adjustment. It gives stability to the machine when this is not coupled to the tractor.



**THE PARKING STAND must always be raised when using the machine.**



**The drawbar must never be used as parking stand for the machine instead of the bearing foot.**

**PROTECTION BAR.** It is fitted to the machine rear side to protect the distribution devices (heads). It must be fitted in the most effective position with respect to the work conditions and type of head.

**SUPPORTING BRACKET.** It is fitted to the drawbar to accomodate the pto shaft when the machine is not coupled to the tractor.



**When the pto shaft is mounted , the bracket must always be down.**  
**THE RESPONSIBILITY OF THE OPERATIONS FOR ADJUSTING, MOUNTING AND DISMOUNTING THE WHEELS IS DELEGATED TO THE OPERATOR, WHO MUST PROVIDE FOR AND ENSURE THE NECESSARY CONDITIONS FOR SAFETY AGAINST POSSIBLE ACCIDENTS.**

**4.2 SWIVELLING DRAWBAR (OPTIONAL)**

IT IS NECESSARY TO USE THE WIDE-ANGLE SWIVELLING DRAWBAR ON THE MACHINE SIDE.

The swivelling drawbar is mounted instead of the standard drawbar with eye. It is fixed to the frame by a bolt with locking plate and self-locking nut. It presents a coupling triangle with 2 pins and the pin of the top link prepared for 3- point hitch cat. "1" and "2".

- \* Cat "1" : pins 22 mm. dia. - top link pin 19 mm. dia.
- \* Cat "2" : pins 28,5 mm. dia. - top link pin 25 mm. dia.

On the drawbar there is a bracket for accomodating the pto shaft when the sprayer is not coupled to the tractor.

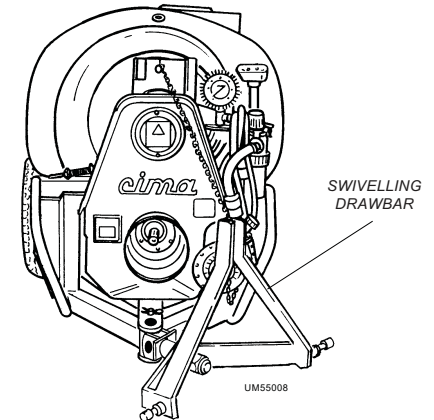

**When the pto shaft is mounted, the bracket must always be down.**

A spring holds up the coupling triangle when this is not inserted in the 3-point arms. The features of the frame are the same as for the standard drawbar (see point 4.1).

### 4.3 - FAN DRIVE

It is placed in the front part of the machine and protected by a polyethylene shaped guard.

#### Drive

Between the input shaft and the fan drive pulley there is a free wheel. In case of sudden decelerations or unexpected motor stop, it permits the fan to continue its free rotation thus avoiding the transmission of violent stresses (see picture) to the organs involved in the movement.

The poly-V belt which transmits the motion to the fan and the "V" belt of the centrifugal pump are equipped with automatic belt tensioner which make maintenance virtually unnecessary.

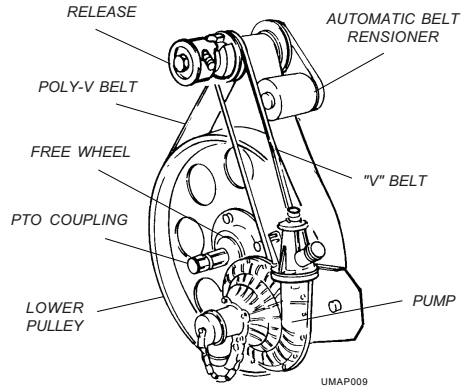

#### Centrifugal fan

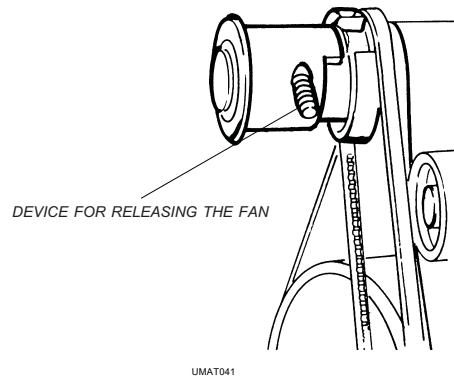
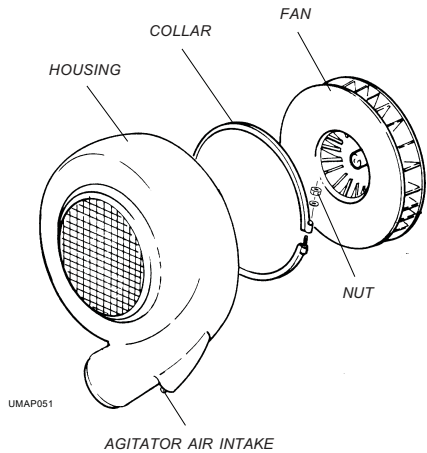

The front release device fitted to the fan shaft allows the running of the centrifugal pump, excluding that of the fan. An air intake on the housing outside the rim allows the pneumatic agitation of the mixture. It is connected to the valve above the tank by means of a pipe. Centrifugal fan with closed blades, in steel sheet metal.

This information ends with some concise specifications regarding some details which characterize to this treatment technique.

The aim is to draw attention to certain aspects that are not normally considered and stimulate conclusions that must unavoidably be thoroughly explored in the opportune seats.

That being stated, it is a good idea for the operator to stop and consider the relationship between the WORKING WIDTH, or the presence of plants with high leaf development and intensity, and the FEED SPEED in determining the SPRAYING CAPACITY PER HOUR.

These two parameters must complement each other and keep the capacity within values which guarantee pulverization adequate to the machine functional features. In other words it is opportune to pay attention to the principle that when the working width value increases, the feed speed value must decrease and viceversa. In the latter case it must be recalled that, to achieve the best results, the speed must always be limited.

On the whole it is therefore opportune to select balanced conditions between the feed speed and the amount of l/ha to spray.

The speed must permit penetration in the leaf mass that is to be treated and the volume of mixture to be distributed must be adequate to cover the whole vegetation surface of the plants without causing dripping.

An appropriate pulverization for a low volume treatment requires the original spraying capacity per hour never to be excessive. Therefore avoid high and above the norm feed speeds. Such conditions would imply the use of capacities that the air speed would not succeed in distributing conveniently.

<p>3 <b>WORKED SURFACE PER HOUR</b></p>	<p>To calculate the hectares treated per hour of work multiply the working width (Lm) by the parameter of feed speed (2): (5 m x 0,52) ..... = <b>2,6 ha</b></p>
<p>4 <b>LITRES PER HECTAR</b></p>	<p>It has been established to carry out the treatment by using a quantity of water per hectare of ..... = <b>200 lt</b></p>
<p>5 <b>SPRAYING CAPACITY PER HOUR</b></p>	<p>The litres the sprayer must spray in 1 hour of work, essential for adjusting the machine, are obtained by multiplying the surface worked per hour (3) by the stated lt/ha (4): (2,6 x 200) ..... = <b>520 lt</b></p>
<p>6 <b>ADJUSTMENT OF THE MACHINE</b></p>	<p>On the capacities table concerning N+N spray heads, look for the value 520 lt (5). Position no. 8 of the adjustment discs, at a working pressure of 2.5 atmospheres corresponds to this capacity. TO ADJUST THE MACHINE IT IS SUFFICIENT TO POSITION ALL DISCS ON NO. 8 AND CARRY OUT TREATMENT WITH A PRESSURE OF 2.5 ATMOSPHERES.</p>
<p>7 <b>MIXTURE BATCHING</b></p>	<p>In the treatments made during the previous season 3 Kg per hectare were distributed. With the atomizer you must use the same quantity of agrochemical product that will be distributed with the 200 lt of water selected to treat one hectare and the mixture must be prepared with 1.5 Kg of agrochemical product every 100 lt of water, i.e. 200 lt with 3 Kg of product per hectare. At the end of treatment 1800 lt of water and 27 Kg agrochemical product will have been distributed on the 9 ha of cultivation.</p>
<p><b>VARIANT TO POINT "6"</b></p>	<p>In case it is decided to carry out the treatment with 250 lt/ha, then the spraying capacity per hour (5) would be 650 lt (250 lt/ha x 2,6 ha). As such value is not listed in the table you must consider the closest one, i.e. 643 lt/h, which recommends the adjustment discs to be set on no. 10 with a working pressure of 1,5 atmospheres. The new capacity per hour of 643 lt divided by the ha/h worked (3) will give the new quantity distributed per hectare: (643 lt/h: 2,6 ha/h) 247 lt.</p>

4.4 - HYDRAULIC CIRCUIT COMPONENTS

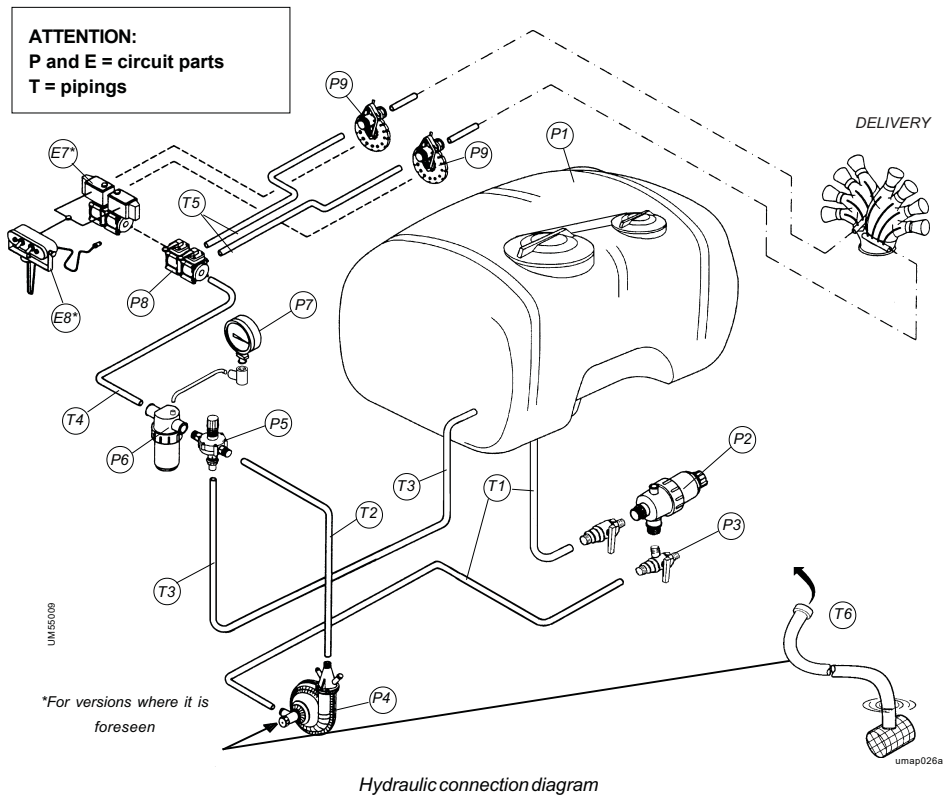

\* P1. TANK

THE POLYETHYLENE TANKS ARE EQUIPPED WITH:

- screw caps with vent valve and plastic cup filters;
- two level gangs with external transparent pipe and scale on the tank;
- hydraulic mixture agitator connected to the return pipe (T3);

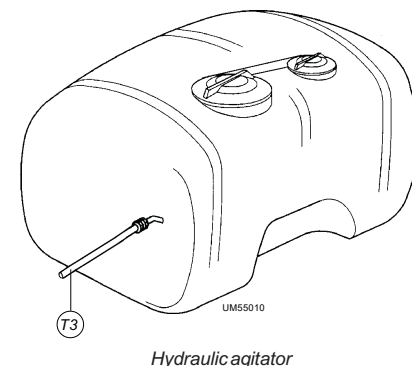

— pneumatic mixture agitator, with tap located on the tank and connected with the guard air intake through a pipe.  
**N.B.** The tap is: **a** = open, **c** = closed

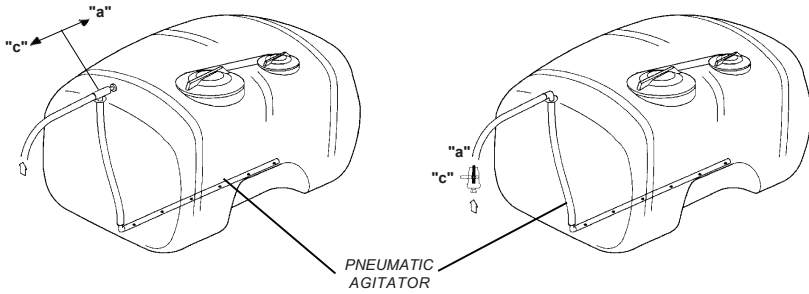

UM55011

— additional polyethylene hand-wash tank with screw cap and service valve: 15 lt.

• **T1. SUCTION PIPING**

It connects the tank with the centrifugal pump. The piping includes the P2 suction filter and the P3 three-ways tap.

• **P2. SUCTION FILTER WITH TAP**

It is connected with the P1 tank through the T1 piping and the lever three-ways tap. The non return valve allows cleaning the cartridge even when the tank is full.

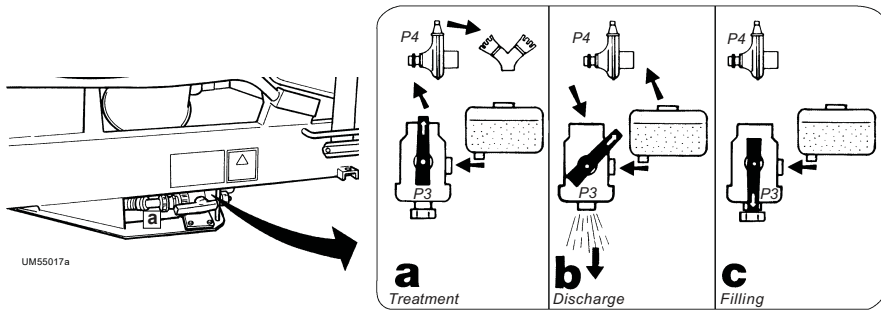

UM55017a

UM55020

• **P3. LEVER THREE-WAYS TAP**

Run of liquid when the lever is in position:

**a. "spraying."**

The liquid comes out and returns to the P1 tank through the P2 filter, the P3 three-ways tap, the P4 pump, the P5 knob cock and the T3 piping. **The spraying is carried out by opening the distributor P7 or E7.**

**b. "discharge."**

The liquid in the P1 tank reaches the P3 tap coming from the P2 filter with cock and through the T3 piping, the P5 cock and the P4 pump. **The circuit discharge happens when the tap's lever is in "b" position.**

**c. "filling."**

The P6 piping is fitted to the P4 pump suction coupling after removing the chain tap. The liquid reaches the P1 tank

TABLE OF CAPACITIES : N+N (\*) SPRAY HEAD

With 2 adjustment discs in position:	SPRAY HEAD SPRAYING CAPACITY (lt./h) with PTO at 540 rpm		
	Working pressure kg/cm2		
	1,5	2	2,5
1	67	81	86
2	107	119	129
3	119	141	155
4	167	186	198
5	219	241	262
6	243	271	293
7	371	409	438
8	438	484	520
9	547	605	655
10	643	719	769
11	852	930	1002
12	1218	1344	1471
13	1534	1788	1957
14	1746	2010	2285
15	2031	2412	2687

UMAP1101

(\*) Indicative values given ONLY as an example. For the adjustment of the machine always refer to the "Use and maintenance manual" of the distribution device.

**Practical example of adjustment**

- A) Treatment with sprayer (equipped with N+N spray head like FAC-SIMILE) on 9 hectares of cultivation with rows of 2,50 mt. in which at each passage 2 rows are covered.
- B) In the treatments performed during the previous seasons, with a traditional normal volume machine, 800 lt. of water and 3 kg. of agrochemical product were distributed, by preparing a mixture with 375 gr. of product for each 100 lt. The treatments required the use of 7200 lt. of water and 27 kg. of agrochemical product.

<b>1</b>	<b>Lm WORKING WIDTH</b>	If at each passage 2 rows of 2,50 mt. distance are covered, the working width to be considered is: (2 rows x mt. 2,50) ..... = <b>5 mt.</b>
<b>2</b>	<b>Km/h 10 FEEDSPEED</b>	After practical operation on the field, a feed speed of 5,2 km/h is stated. This value, divided by 10, gives a parameter of ..... = <b>0,52</b>

**TABLE SUMMARIZING THE NECESSARY OPERATIONS FOR ADJUSTING THE MACHINE**

1 TO DETERMINE WORKING WIDTH	2 TO STATE FEED SPEED	3 TO OBTAIN WORKED SURFACE PER HOUR	4 TO STATE LITRES PER HECTARE	5 TO OBTAIN SPRAYING CAPACITY PER HOUR
distance in metres between the rows multiplied by the number of rows covered at each passage	according to the gear selected to carry out the treatment in km/h, divided by 10	hectares treated per hour due to the working width multiplied by the feed speed	quantity of water selected to treating the hectare expressed in litres	quantity in litres that the machine must distribute per hour to perform the established treatment
<b>Lm</b>	<b>x</b>	<b>km/h</b>	<b>=</b>	<b>ha/h</b>
		<b>10</b>		<b>x</b>
				<b>l/ha</b>
				<b>=</b>
				<b>l/h</b>
<b>6 MACHINE ADJUSTMENT</b>				
<p>In the Table of capacities, supplied with each spray head, look for the spraying capacity per hour obtained (5). Take note of the adjusting disc number, from 1 to 15, and of the working pressure value.</p> <p>If the value of spraying capacity per hour (5) does not coincide with those given in the table, make reference to the closest one. The new value, divided by the worked surface per hour (3) gives the new amount of litres sprayed per hectare.</p> <p>POSITION ALL ADJUSTMENT DISCS OF THE MACHINE ON THE NUMBER FOUND AND CARRY OUT TREATMENT WITH THE CORRESPONDING WORKING PRESSURE GIVEN IN THE TABLE.</p>				
<b>7 MIXTURE BATCHING</b>				
<p>The quantity of agrochemical product to be employed must be calculated based on the surface to be treated. Independently from the type of equipment or the litres of water employed, each hectare of cultivation always needs the same quantity of product.</p> <p>FOR EACH HECTARE OF CULTIVATION ONE MUST EMPLOY THE SAME QUANTITY OF PRODUCT DISTRIBUTED DURING THE TREATMENTS OF THE PREVIOUS SEASONS, MIXING IT WITH THE VOLUME OF WATER SELECTED FOR THE TREATMENT.</p> <p>To rationalize the treatment, remember that "quantity distributed per hectare in the previous seasons" means that part of product actually distributed over the cultivation. If it refers to treatments made with normal volume systems, then the dose of agrochemical product per hectare can be reduced.</p>				

through the P5 cock and the T3 piping. **The filling is carried out when the lever of the P3 tap is in "c" position (chain tap) and the cocks of the P8 manual distributor are closed.**

• **P4. CENTRIFUGAL PUMP**

Model C.I.M.A. CD32 - Molded in nylon - Open impeller - Stainless steel shaft - Mechanical seal in silicon carbide and viton - Discharge valve - Suction coupling with additional service union with chain tap. The pump is driven by a "V"-belt, driven by the pulley fitted to the fan shaft.

• **T2. DELIVERY PIPING**

It connects the P4 pump with the P5 pressure adjusting valve.

• **P5. PRESSURE REGULATOR**

It is connected with the P6 delivery filter and pipings T2 and T3.

It adjusts the working pressure by controlling the flow returning to the tank.

— It opens when the knob is turned clockwise; the flow returning to the tank increases and the working pressure decreases.

— It closes when the knob is turned counter-clockwise: the flow returning to the tank decreases and the working pressure increases.



**The regulator must be fully open for mixture agitation and filling operations.**

• **T3. RETURN PIPING**

It connects the P5 valve with the P1 tank at the point fitted with the hydraulic agitator.

• **P6. DELIVERY FILTER**

It is connected to the P5 cock and the P7 monometer. A ring nut locks the cover to the filter body.

Filter capacity 240 lt./min. - Filtering cartridge: 50 meshes.



**A dirty cartridge causes a drop in the working pressure. The problem is indicated by the manometer.**

The filter is fitted to the delivery and filters only the supply flow to the distribution devices, thus remarkably reducing the possibility for cartridge clogging.

• **P7. PRESSURE GAUGE**

In glycerine bath - Dial from 0 to 6 kg/cm<sup>2</sup> (atmospheres) - adjustment scale 1/10 of atmosphere.



**To select the working pressure the valve of the P8 manual distributor or P7 electric distributor must be open.**

**The pressure must be checked again when it is necessary to operate with a closed valve.**

• **T4. SUPPLY PIPING**

It connects the P7 manometer to the P8 two-way manual distributor or the E7 electrical one where this is provided.

• **P8. MANUAL DISTRIBUTOR WITH 2 LEVERS COCKS**

It is connected to the T4 piping and the two T5 distribution pipings.

It remote controls the spraying opening and closing.

Fix the anchor bracket supplied with the machine on the tractor, within the driver's reach. During treatment the distributor must be inserted into the fastening bracket by means of its bayonet. When the machine is not coupled to the tractor, the distributor must be set in the appropriate seat on the frame, in the front part of the machine.

Each valve permits the spraying from one head side only: right or left.

The cock is **open** when the lever is **vertical**, and **closed** when it is **horizontal**.



#### • E7. ELECTRIC DISTRIBUTOR

It is connected to the E8 electric control unit, the T4 supply piping and the T5 distribution pipings.

The valve open and close electrically.

Each valve permits spraying from one head side only: **right** or **left**.

#### • E8. ELECTRIC CONTROL UNIT

It is electrically connected with the E7 distributor and the socket on the tractor. The unit is delivered with a complete socket, in case the one on the tractor is not suitable for connection.

The 2 lever switches, controlling the E7 cocks, must be turned to **"ON"** for **opening** and to **"OFF"** for **closing**.

The unit is equipped with a bayonet support, to be inserted in the standard bracket. This bracket must be fixed to the tractor in the reach driver's. When the machine is not coupled to the tractor, it must be set in the appropriate seat on the frame, in the front part of the machine.

#### • T5. DISTRIBUTION PIPING

It connects the distributor P8/E7 with the P9 rotating disk adjustment unit, mounted on the distribution devices.

#### • P9. CALIBRATION DISK ADJUSTMENT UNIT

It selects the necessary deliveries during treatment and is mounted on the distribution devices.

Two flanges, held by two wing nuts, secure a disk with calibrated holes numbered from 1 to 15. A slot in the disk rim allows the accurate positioning of the hole to be used. Its number must appear in the semicircular seat of the flange. The disk rotation is obtained by unscrewing the wing nuts by a few turns. At the end of the operation carefully rescrew the wing nuts.



**ANY LACK IN THE SEAL OF THE HYDRAULIC CIRCUIT MAY CAUSE INTERMITTENT DELIVERY IN SPRAYING. CAREFULLY CHECK THE EFFICIENCY OF GASKETS AND CLAMPS, THE TIGHTENING OF RING NUTS AND UNIONS AND THE INTEGRITY OF THE PIPINGS.**

After you have acquired sufficient operative experience, the modalities of preparation of the mixture can be partially modified, to obtain all the advantages offered by a low volume treatment from the sprayer.

In fact, differently from what was previously said, the quantity per hectare can be reduced by approx. 25% without compromising the result of treatment.

This reduction of doses is suggested to the farmer who understands the functional principles of this technique and its practical possibilities, and wants to finalize his activity in the most economical way. To avoid the perplexities and fears that might be raised by this new operative condition, one must consider the different coverage modalities between the two treatment systems.

- When operating with traditional normal volume machines, the quantity of mixture prepared for treatment is used in an **ANTIECONOMICAL** way and without evaluating the possible negative consequences for the environment. With this coverage technique, in fact, one has a 25% average loss of the mixture employed, due to dripping on the ground, and dispersion in out-of-target treatment. It is therefore evident that, even with the traditional system, the treatment is made distributing over the vegetation surface only 75% of the prepared volume of mixture, corresponding to a quantity of active principle reduced by 25% with respect to quantity estimated at the beginning. The need to prepare a volume of mixture greater than the real requirements of the cultivation comes only from the coverage technique that, to distribute on the vegetation the necessary dose, i.e. 75% of that quantity, unavoidably disperses the remaining 25%. **"Therefore, of the 3 kg. of agrochemical product per hectare mentioned in the example, only 2250 gr. (75%) will actually be distributed on the plants, and the remaining 750 gr. (25%) will be dispersed in the environment"**.
- A correct use of our pneumatic equipment, on the contrary, eliminates this negative aspect and its relevant consequences. The essential characteristics of a low volume treatment is to carry out treatments without mixture dripping. If this happens, it means that the sprayer is not used according to its real operative possibilities. The numerous distribution devices that can be employed on our machines, also eliminate the dispersion effect. They allow, in fact, **"appropriate"** and **"specific"** treatments, as the air flow can be adapted to the shape of plants and the mixture distribution can be differentiated according to the real existing needs in different parts of the same plant. Therefore, with obvious economic advantage, this treatment system permits the reduction of the dose of agrochemical product per hectare normally foreseen, by that 25% imputable to "dripping" and "dispersion", without compromising the coverage efficiency. The validity of this method is confirmed by the observation that both systems perform the coverage by distributing over the vegetation surface 75% of the dose indicated at the beginning. **"Reducing the 3 kg. of agrochemical product per hectare, considered in the example, by 25%, the mixture shall be prepared with 2250 gr., that will be fully distributed on the plants. "**

COCK OPEN.

When the value of the original spraying capacity does not match with those given in the table, you must take into consideration the nearest value and its adjustment data. By dividing this new value by the surface worked per hour (point 3) you will get the new quantity of liters sprayed per hectare. It will not be much different from the one previously stated.

## 7 Mixture batching

**The quantity of agrochemical product to be used in the preparation of the mixture, must be calculated only according to the surface to be treated. INDEPENDENTLY FROM THE TYPE OF EQUIPMENT OR THE LITERS OF WATER EMPLOYED, EACH HECTARE OF CULTIVATION ALWAYS NEEDS THE SAME QUANTITY OF PRODUCT.**

Considering that the surface of cultivation being treated is usually always the same, it results that, depending on the moment of treatment, also the quantity of product to be employed does not change and is the same as that employed for the treatments performed during the previous seasons. Therefore, the needed quantity of agrochemical product per hectare is a value that can be considered constant and always known by those who carry out treatments.

With our sprayer, the product needed for the treatment may be distributed (see point 4) with a very reduced volume of water with respect to the traditional normal volume apparatuses. This implies the preparation of concentrated mixtures and the smaller the quantity of water used for treatment, the higher the concentration will be.

Here are some indicative examples for preparing the mixture, assuming that one hectare cultivation is to be treated, in which 3 Kg. of product have always been used:

### TRADITIONAL NORMAL VOLUME MACHINE

with 3 kg. in 1000 lt/ha = 300 gr. of product in 100 lt. of water  
concentration "1 time" = normal volume

### PNEUMATIC LOW VOLUME SPRAYER

with 3 kg. in 400 lt/ha = 750 gr. of product in 100 lt. of water  
concentration "2.5 times" (1000:400)

with 3 kg. in 300 lt/ha = 1000 gr. of product in 100 lt. of water  
concentration "3.3 times" (1000:300)

with 3 kg. in 250 lt/ha = 1200 gr. of product in 100 lt. of water  
concentration "4 times" (1000:250)

with 3 kg. in 200 lt/ha = 1500 gr. of product in 100 lt. of water  
concentration "5 times" (1000:200)

## 4.5 - TECHNICAL DATA

### 4.5.1- Machines dimensions and weights

(With rudder and protection bar - Without distribution device - Without accessories)

		Tank capacity (litres)				
		600	800	1000	1500	2000
BLITZ 45T	Total width (mm)	1060	1090	1380	-	-
	Total height (mm)	1250	1370	1370	-	-
	Total length (mm)	3050	3310	3350	-	-
	No-load weight (kg)	342	380	420	-	-
	Full-load weight (kg)	966	1204	1444	-	-
BLITZ 50T 50T1500	Total width (mm)	1060	1090	1380	1660	-
	Total height (mm)	1250	1370	1370	1480	-
	Total length (mm)	3100	3370	3430	4300	-
	No-load weight (kg)	374	412	450	550	-
	Full-load weight (kg)	998	1258	1500	2125	-
BLITZ 55T BLITZ 55TS BLITZ 55TE	Total width (mm)	-	-	1530	1660	1720
	Total height (mm)	-	-	1440	1480	1720
	Total length (mm)	-	-	3450	4300	4300
	No-load weight (kg)	-	-	494	580	608
	Full-load weight (kg)	-	-	1544	2155	2708

UM55T01



Weight of the swivelling drawbar: 38 kg., to be added to the sprayer weight (when used).

The installation of the swivelling drawbar does NOT involve any modification in the total machine length.

### 4.5.2 - TYRES: sizes and working pressure

MODEL	SIZE	HUB	PRESSURE	DECALS CODES
BLITZ 45T 600 - BLITZ 50T 600	175/80.13	5 F	atm. 2,5	95056
BLITZ45T 800 - BLITZ 50T 800	7,00-12	5 F	atm. 2,5	95056
BLITZ45T 1000 - BLITZ50T 1000	10/80.12	5 F	atm. 3,3	95060
BLITZ55T-55TS-55TE 1000	10,0/75.15,3	6 F	atm. 3,3	95060
BLITZ50T-55T-55TS-55TE 1500	10,0/75.15,3	6F	atm.3,3	95060
BLITZ55T-55TS-55TE 2000	11,5/80.15,3	6F	atm.3,3	95060

UM55T021

### 4.5.3 - Fan-pump specifications

#### Centrifugal fan

	BLITZ 45T	BLITZ 50T	BLITZ 55T	BLITZ 55TS	BLITZ 55TE
Fan diameter (mm)	450	500	550	550	550
Fan speed (rpm)	4500	4000	3450	3720	3900
Air capacity (m3/h)	5400	7550	12500	14000	15500
Air speed (m/s)	188	175	150	170	180
Absorbed power (kW)	17	24	28	36	43

UM85T041

#### Centrifugal pump CD32

- Speed ..... 4250 rpm.
- Capacity ..... 140 lt/min.
- Max. pressure ..... 4,5 Kg/cm<sup>2</sup>
- Absorbed power ..... kW 2,5



The declared performances can be obtained with PTO at 540 rpm.  
This condition must never be exceeded during the use of the machine.

### 4.5.4 - Fan technical specifications

	BLITZ 45T	BLITZ 50T	BLITZ 50T1500	BLITZ 55T	BLITZ 55TS	BLITZ 55TE
Steel fan	YES	YES	YES	YES	YES	YES
Plastic housing	YES	YES	YES	YES	YES	YES
90° elbow union	YES	YES	YES	-	-	-
Inside diameter of housing outlet opening (mm)	175	175	250	250	250	250
PTO shaft 1"3/8 SAE (DIN 9611/A)	YES	YES	YES	YES	YES	YES
Main pulley diameter (mm)	450	480	480	480	480	480
Fan drive belt	650J32	690J50	690J50	690J50	690J50	690J50
Fan pulley diameter (mm)	54	64,5	64,5	75	70	66
Pump drive pulley diameter (mm)	78	88	88	101-96	101-96	88
Pump drive belt	3V 500	3V 500	3V 500	3V 500	3V 500	3V 500
Pump pulley diameter (mm)	82,5	82,5	82,5	82,5	88	82,5

UM85T051

### 4 Determining the litres to be sprayed per hectare = "l/ha"

After determining the previous parameters it is necessary to find out how many litres of water must be employed to treat one hectare.

This choice, which is limited only by the condition that it ensures the coverage of the cultivation, is left to the user and to his working capacities. From this point of view the options may satisfy every need, even the most difficult one. Normally, a rational use of our sprayer requires 1/4, 1/5 and even 1/10 of the volume required by a traditional normal volume machine.

As an indication, for one hectare of normal orchard approx. 300/350 lt. can be used, while, for a vineyard it is impossible to reduce the volume to 100/200 lt. Of course these data represent an average of the values normally used. The choice of the volumes to be used per hectare depends, in fact, on the plant structure, their leaf density and the climatic conditions at the moment of treatment. With high ambient temperatures, the choice of very low volumes is not recommended.

Finally, and in case it is necessary, with our sprayer you can make selections that allow normal volume treatments.

### 5 Spraying capacity per hour = "lt/h"

It indicates the litres the sprayer must spray in one hour to carry out the treatment with a stated volume of mixture per hectare.

This parameter has already been substantially defined with the information given till now.

BY MULTIPLYING THE HECTARES TREATED PER HOUR (ha/h) BY THE STATED LITRES PER HECTARE (lt/ha) ONE OBTAINS THE SPRAYING CAPACITY PER HOUR (lt/h), according to which the sprayer will be adjusted.

$$ha/h \times lt/ha = lt/h$$

### 6 Adjustment of the machine

The knob cock (P5), connected to the piping returning to the tank, adjusts the pump discharge flow and, consequently, the treatment working pressure.

By means of the knob it is possible to gradually pass from a zero value of pressure, with open cock, to the max. value, with closed cock. Every change in pressure is shown on the manometer (P7), which allows adjustments of 1/10 of atmosphere.

The adjuster with rotating disc, with 15 calibrated and numbered holes, allows the machine to be used with 15 different capacities, depending on the selected pressure value.

Each distribution device (spray head) comes with a "Use and maintenance manual" in which there is a table showing some pressure values with the 15 corresponding capacities.

Only those values which offer a range of capacities suitable to satisfy every possible operative need are considered. Look in the table for the value of the spraying capacity per hour determined in point 5: you will see a position number on the rotating disc, from 1 to 15, and a pressure value.

AFTER POSITIONING ALL ROTATING DISCS ON THE NUMBER INDICATED, YOU CAN BEGIN THE TREATMENT, BEARING IN MIND THAT THE WORKING PRESSURE VALUE MUST BE THE ONE OBTAINED FROM THE TABLE. THIS VALUE MUST BE SET ON THE MANOMETER (P7) WITH THE MANUAL (P8) OR ELECTRIC (E7) DISTRIBUTOR

Before finishing it is necessary to point out the importance of the feed speed for a rational and economically profitable treatment. A correct intervention requires that the mixture cloud penetrates the structure of the row, spraying the whole vegetation surface, and that it comes out beyond the plants, avoiding to involve wide areas of empty space. Disregarding this condition causes a dispersion of product. This inconvenience may be avoided by increasing the feed speed so as to reduce the time of penetration of the air flow in the row and maintain the mixture output within the limits required to avoid product dispersion. When the structural characteristics of the cultivation and the functional ones of the sprayers allow it, the speed may also be reduced. This choice, which increases the time of penetration, must be made only when pulverization can also reach and cover the rows contiguous to those in which the passage occurs.

### 3 Worked surface per hour = "ha/h"

It is the surface of ground which contains the cultivation covered in one hour of effective treatment.

The idle times for preparation, loading, transfert, etc. are not taken to consideration.

This parameter is easy to determine and you can have it using the two parameters obtained above. It is of fundamental importance because, only by knowing the exact surface worked per hour, it is possible to calculate the quantity of water the sprayer must spray in one hour, in order to carry out the treatment with the selected litres per hectare. In short, to state how many hectares of ground can be worked in one hour, it is sufficient to use the following formula:

$$Lm \times \frac{km/h}{10} = ha/h$$

BY MULTIPLYING THE VIRTUAL WIDTH OF TREATMENT IN METERS (Lm) BY THE FEED SPEED IN KILOMETERS PER HOUR DIVIDED BY TEN (km/h: 10) YOU GET THE SURFACE WORKED IN HECTARS PER HOUR (ha/h).

It is obvious that if the working width remains unchanged during the treatment, the worked ha/h changes if the speed is increased or decreased.

If a cultivation has 3 mt distance between the rows, and at each passage 2 rows are covered, the virtual working width of 6 mt (3 mt x 2) always remains unchanged, while the surface worked per hour changes according to the gear selected for treatment:

- at 4 km/h = (4 x 6 mt = 24, divided by 10) 2,4 worked ha/h
- at 4,5 km/h = (4,5 x 6 mt = 27, divided by 10) 2,7 worked ha/h
- at 5 km/h = (5 x 6 mt = 30, divided by 10) 3 worked ha/h

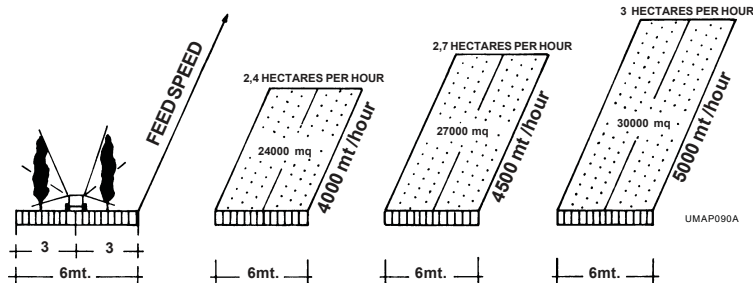

## 5 HITCHING MODE 5

### 5.1 - TRACTOR HOOK-UP



THE SPRAYER IS NOT APPROVED FOR DRIVING ON THE ROAD.



To be coupled with tractors of at least	BLITZ 45T	BLITZ 50T	BLITZ 55T	BLITZ 55TS	BLITZ 55TE
CV SAE	45	65	70	80	90
kW	33	48	52	59	66

THE TRACTOR'S PTO SHOULD DELIVER A POWER HIGHER THAN THAT ABSORBED BY THE SPRAYER UNDER ALL WORK CONDITIONS.

#### 5.1.1 Sprayer with standard drawbar

##### EXECUTION

- The coupling should be done on a flat surface, taking care of clearing away all the people not involved in the operation, including children and animals.
- The tractor drawbar should be in central position.
- Put the tractor near and in line with the sprayer.



4. Stop the tractor. Take the keys out of the control panel.

- Adjust the rudder length. The drawpoint should be as far as possible equidistant from the 2 PTO's.
- Choose the position of the trail eye: up or down. The sprayer should operate as horizontal as possible. If the ground allows it, also adjust the axle height.
- Fix the rudder to the frame.
- Position the rudder trail eye at the same height as the trail fork, by adjusting the bearing foot.
- Start the tractor and insert the trail eye in the fork, following the instructions of point 1.



10. Stop the tractor. Take the keys out of the control panel.



- Lock the hook by means of the safety release pin.
- Completely lift the bearing foot.
- Place the 2-cocks P8 manual distributor or the E8 electric control unit near the driver by inserting its supply plug into the tractor socket.
- Screw the two supply pipes to the distribution device (head).

#### 5.1.2 Sprayer with swivelling drawbar



##### EXECUTION

- The hitching should be made on a flat surface, taking care of clearing away all the people not involved in the operation, including children and animals.

2. Loosen the chains of the 3-point arms.
3. Start the tractor and bring the 3-point arms to the height of the steering rudder pins.

4.   Stop the tractor and take the key out of the control panel.

5. Fit pto shaft on the machine side, locking them with the release pins.
6. Fix the tractor top link to the steering rudder and lock it with pin and release pin.
7. Completely lift the parking stand.
8. Start the tractor and lift the atomizer until the two PTO's are at the same height.

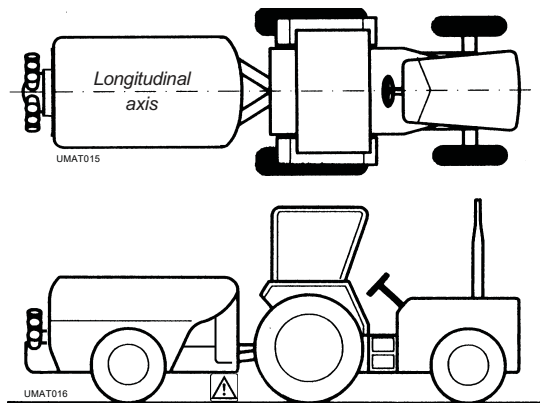

9.   Stop the tractor, take the key out of the control panel and make sure that nobody touches the hydraulic controls of the 3-point lift.  
Avoid operating or staying under the machine or on the surface which could be affected by a sudden lowering the machine.



10. By means of the top link, set the axis of the 2 PTO's on the same plane.
11. Lock the 3-point by tightening the chains of the 3-point lift.

11.  At the end of the operation the 2 PTO's must be positioned on the same plane.

### 5.2 PTO - SHAFT

-   The assembling, disassembling or possible works on the drive joint must be carried out when the engine is stopped and the key is out of the tractor control panel.

-  Use drive joints with CE certificate.

### 3 = THREE ROWS, $L_m = 3D$ (mt 9)

The virtual width corresponds to a strip of land three times as wide as the distance between the rows. It requires a passage every two rows.

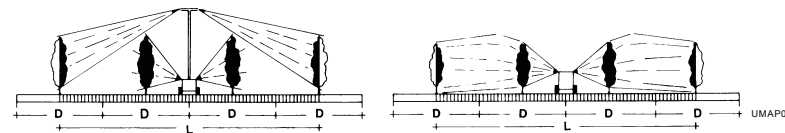

### 4 = FOUR ROWS, $L_m = 4D$ (mT 12)

The virtual width corresponds to a strip of land four times as wide as the distance between the rows. It requires a passage every three rows.

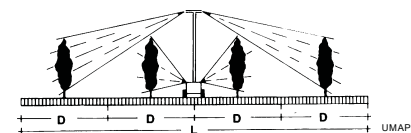

### SIDE FULL FIELD

The virtual width corresponds to the distance in meters actually covered by the pulverization.

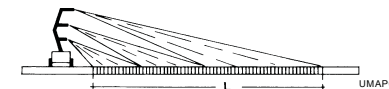

For those who are going to employ an sprayer for the first time, it is suggested that the "virtual width of treatment" be determined after you have verified in practice its coverage capacity. In fact, during the season, this width may change with respect to the moment of treatment: in some cultivations more rows are covered at the beginning of the vegetation cycle than those covered during the period of maximum vegetation.

## 2 Feed speed = "km/h"

This is the speed of the tractor-sprayer operative unit when carrying out treatment.

It must be decided in practice on the field, depending on the ground conditions, how the cultivation is planted and the type of sprayer employed. It is also essential to select a gear which respects the functional characteristics of the machine. Normally, a speed lower than that used with traditional low volume apparatuses increases the treatment quality and efficiency without reducing its operative capacity.

THE FEED SPEED IN km/h IS DEDUCED FROM THE SPEEDS DECLARED FOR EACH TRACTOR, FOR THE GEAR SELECTED FOR TREATMENT.

Knowing the length in meters of a row (mt) and calculating the time in seconds (sec) to cover it, it is possible to check or calculate the feed speed.

It is sufficient to use the formula: " $mt \times 3,6 : sec = km/h$ " (row length in metres, multiplied by 3,6 and divided for the seconds spent = km/h).

As an example "D" is stated to be 3 mt.

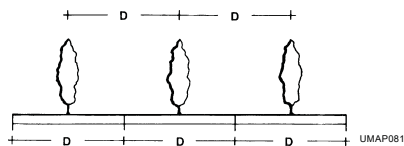

**ROWS COVERED AT EACH PASSAGE**

**0,5 = HALF ROW**,  $L_m = D:2$  (mt 1,50)

The virtual width corresponds to a strip of land as wide as half of the distance between the rows. It requires two passages for each row.

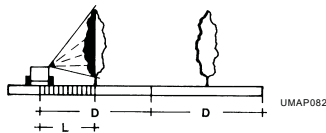

**1 = ONE ROW**,  $L_m = D$  (mt 3)

The virtual width corresponds to a strip of land as wide as the distance between the rows. It requires one passage for each row.

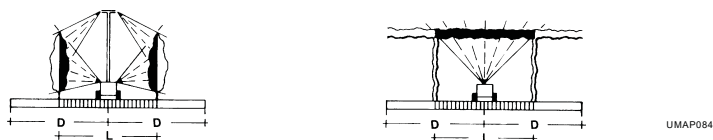
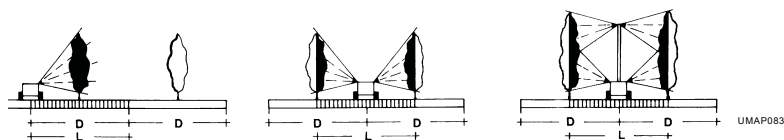

**2 = TWO ROWS**,  $L_m = 2D$  (mt 6)

The virtual width corresponds to a strip of land twice as wide as the distance between the rows. It requires the passage every other row.

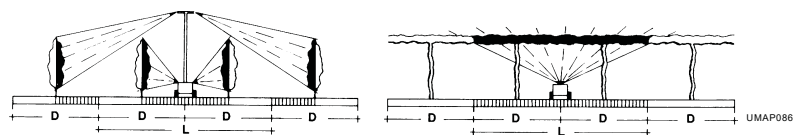
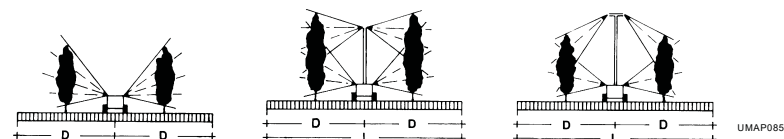

**5.2.1 Drive joints**

The 2 halves should be assembled when the 2 PTOs are parallel. Prevent the pto from working with angles wider than 15°.

The operating conditions may also be obtained by adjusting the drawbar (height and length).

When turning with the PTO running the steering angle may be 30° only if the hitch point is equidistant from the PTOs. At an angle any greater than this, it will be necessary to stop the PTO to prevent breakages and danger.



**THE USER IS IN ANY CASE OBLIGED TO RESPECT THE INSTRUCTIONS CONTAINED IN THE USE AND MAINTENANCE MANUAL SUPPLIED BY THE PTO SHAFT MANUFACTURER.**

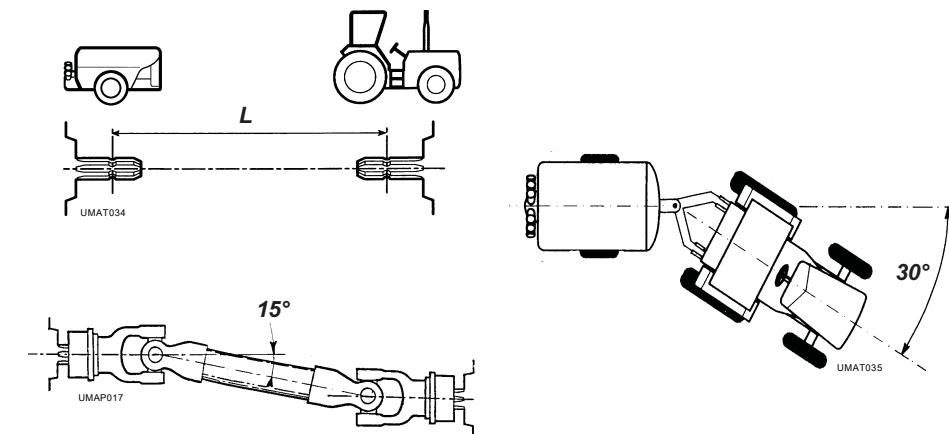

**DETERMINING THE LENGTH.**

1. Hook the atomizer to the tractor and set the operational unit to the max. allowed turning position.
2. Measure the distance "D" between the 2 PTO grooves.
3. The length "L" of the drive joint to be used should be at least 25 mm. shorter that the distance D:  
"L = D-25 mm"

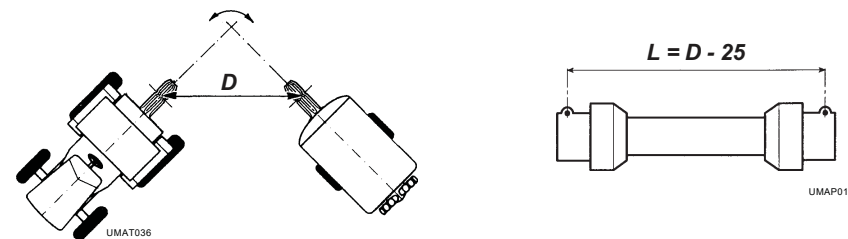

### 5.2.2 Transmission with a single wide angle pto joint (machine side)

The drive joint should be assembled when the 2 PTOs are coaxial or, if this is not possible, when their axes are parallel.

These operating conditions may also be obtained by adjusting the drawbar.



**THE WIDE ANGLE PTO MUST BE FITTED ON THE SPRAYER SIDE AND MUST BE IN CORRESPONDENCE WITH THE ARTICULATION AND DRAWPOINT. Under these conditions, when the PTO is running, it is possible to make curves with steering angles of 70/80°.**



**THE USER IS IN ANY CASE OBLIGED TO RESPECT THE INSTRUCTIONS CONTAINED IN THE USE AND MAINTENANCE MANUAL SUPPLIED BY THE PTO SHAFT MANUFACTURER.**

#### DETERMINING THE LENGTH

- Follow the same instructions as the one given in Paragraph 5.2.1.

### 5.3 - INSTALLATION OF REMOTE CONTROLS.

#### 5.3.1 - P8 - 2 valve manual distributor

- 1 - Fix the fastening bracket onto the tractor, within the driver's reach.
- 2 - Insert the distributor bayonet support into the fastening bracket.
- 3 - Connect the T5 distribution pipings to the hydraulic circuit of the distribution device (head) fitted to the machine (follow the instructions of the use and maintenance manual supplied by the manufacturer).



**Position the T5 distribution hosing and T4 delivery hosing so as to protect them from damage during the spraying. If possible use appropriate fastening clamps.**

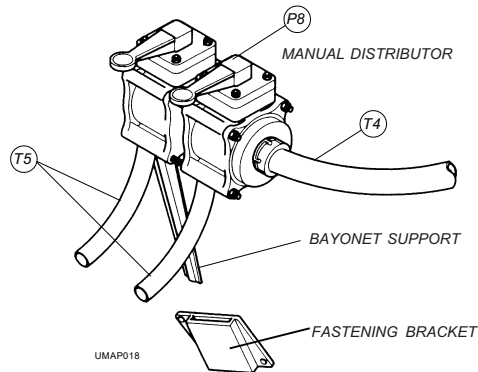

### 11.2 - DETERMINING THE ADJUSTMENT DATA

The technical principle of "PULVERIZATION AND PNEUMATIC TRANSPORT OF THE AGROCHEMICAL MIXTURE WITH DELIVERY ADJUSTMENT" used on our sprayers, remarkably enhances the traditional water coverage capacities and ensures, with much reduced employment volumes, high-quality treatments, which are economically profitable and respond to the present **IMPERATIVE** need to protect the environment against pollution.

To these positive operative conditions the possibility of carrying out treatments in which the volume of mixture to be distributed per hectare is decided by the user according to his needs and capacity must be added.

Of course, to perform this type of treatment, all sprayers must be duly adjusted before being used. This operation is very simple but can only be done after determining some parameters related to the structural characteristic of the cultivation to be treated and corresponding to the results that must be achieved.

To this aim, it is therefore essential to specify what the parameters are and, moreover, what modalities are to be followed in order to determine them.

#### 1 Virtual width of treatment = "Lm"

**This measurement indicates the width of the field including the number of rows treated at each passage.**

To make the determination of this parameter easy, it must be considered that each row occupies a strip of land, whose width of which is equal to the distance between the rows.

In a cultivation where the a.m. distance is 3 mt., each row occupies a strip of land 3 mt. wide: 1,5 mt. on one side and 1,5 mt. on the other. If each passage covers 2 rows, corresponding to 2 strips of land, the virtual width of treatment will be 6 mt.

The VIRTUAL WIDTH OF TREATMENT IS therefore OBTAINED by MULTIPLYING THE NUMBER OF ROWS TREATED AT EACH PASSAGE, BY THE DISTANCE IN METERS BETWEEN THE ROWS OF THE CULTIVATION. The calculation must of course also consider the half rows.

Determining this parameter is very simple because it is obtained from the defined and known measures which characterize the cultivation implantation on which treatment shall be carried out.

When distribution devices (spray heads) at "full field with side distribution" (cannon jets for tobacco or similar) are employed, the width in meters covered by the pulverization must be considered.

To clarify this explanation, a concise illustration of the various possibilities of coverage of the standard available distribution devices is provided. The graphic indications represent the different conditions of the ground, and may help to better understand the modalities for determining this parameter, according to the specific characteristics of each treatment. It must be pointed out that the different possibilities depend on how the cultivation is planted, the structure and development of plants, the configuration of the ground and the power of the available tractor.





#### • REPRESENTATION OF THE VIRTUAL WIDTH OF TREATMENT = "Lm"

PRELIMINARY CONSIDERATION - "D" indicates the distance in meters between the cultivation rows. This measure is equal to the width of the strip of land occupied by each row.

**FOR THE TREATMENT OF THE SAME SURFACE**

	MACHINE USED	PULVERIZATION SYSTEM	PRODUCT EMPLOYED	WATER EMPLOYED	MIXTURE CONCENTRATION
1 ha	AIR-ASSISTED	NORMAL VOLUME	Kg 3	1000 lt.	ONCE OR NORMAL = 300 g/100 lt.
	PNEUMATIC SPRAYER	LOW VOLUME	Kg 3	500 lt.	TWICE OR DOUBLE = 600 g/100 lt.
	PNEUMATIC SPRAYER	LOW VOLUME	Kg 3	250 lt.	4 TIMES OR QUADRUPLE = 1200 g/100 lt.

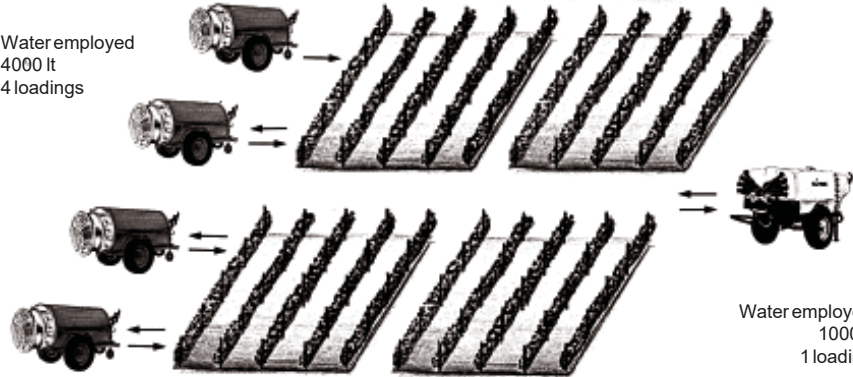
UMAP091

<p><b>NORMAL VOLUME</b> Treatment of 1 hectare with 1000 lt. of water and 3 Kg of product.</p> <p><b>AIR-ASSISTED</b> 1000 lt</p>  <p>Mixture concentration: Once or normal.</p>	<p><b>LOW VOLUME</b> Treatment of 1 hectare with 3 Kg of product. The concentration of the mixture is to be selected, depending on the lt./ha to be employed.</p> <p><b>PNEUMATIC SPRAYER</b> 250 lt</p>  <p>Mixture concentration: 4 times or quadruple.</p>
<p><b>COVERAGE OF 4 HA</b> with 12 Kg of product</p>	
<p><b>AIR-ASSISTED</b> 1000 lt</p> <p>Water employed 4000 lt 4 loadings</p>  <p>Mixture concentration: Once or normal.</p>	<p><b>PNEUMATIC SPRAYER</b> 1000 lt</p> <p>Water employed 1000 lt 1 loading</p>  <p>Mixture concentration: 4 times or quadruple.</p>

UMAP080

IN CASE OF BREAKAGE:



- 1 - Stop the tractor and take the key out of the control panel.
- 2 - Shut the 2 valve of the "P8" distributor.
- 3 - Put the lever of the "P3" three-way valve in "C" position, i.e. filling.
- 4 - Shut the P5 pressure adjustment knob cock (turn clockwise).

**5.3.2 - E8 - Electric control unit**

- 1 - Fix the fastening bracket onto the tractor in the driver's reach.
- 2 - Insert the distributor's bayonet support into the fastening bracket.
- 3 - Connect the W1 supply cable by inserting the plug into the tractor socket.



The W1 supply cable is supplied complete with electric socket, to be fitted to the tractors which have none or to replace the existing one if it does not match with the plug.

4. Connect the T5 distribution hoses with the hydraulic circuit of the distribution device (head) fitted to the machine (follow the instructions of the use and maintenance manual delivered by the manufacturer).

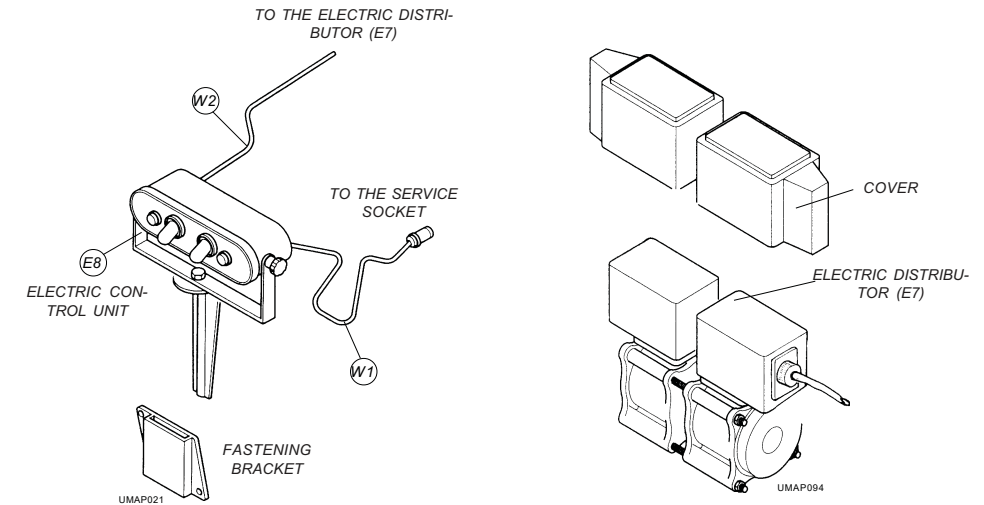

Position the W1 and W2 electric cables so as to protect them from damage during spraying. If possible, use appropriate fastening clamps.



**6 DISTRIBUTION EQUIPMENT 6**

**O** Each distribution device is supplied with its **USE** and **MAINTENANCE** manual which must, or shall be, considered as an enclosure to this publication.

**6.1 - TYPES AND IDENTIFICATION CODES**

Distribution device - Spray Head	BLITZ 45T	BLITZ50T	BLITZ50T1500	BLITZ55T	BLITZ55TS	BLITZ55E
4+4 diffusers spray head with 8 taps	T.4+4.45.01	T.4+4.50.01	T.4+4.50.01	-	-	-
5+5 diffusers spray head with 10 taps	T.5+5.45.01	T.5+5.50.01	T.5+5.50.01	-	-	-
Strasbourg type spray head with 4+4 diffusers and 8 taps	T.ST4.45T.01	T.ST4.50T.01	-	-	-	-
Midi spray head and 600 mm extension	T.MD.P06.45.01	T.MD.P06.01	-	-	-	-
Tendone spray head with 7 diffusers	T.TND.45.01	T.TND.50.01	T.TND.50.01	-	-	-
Multiple spray head for olive-tree with 4 diffusers	T.OL.000.45.01	T.OL.000.50.01	T.OL.000.50.01	T.OL.000.55.01	T.OL.000.55.01	T.OL.000.55.01
Multiple spray head for olive-tree with 4 diffusers and 600 mm extension	T.OL.P06.45.01	T.OL.P06.50.01	T.OL.P06.50.01	-	-	-
Multiple spray head for olive-tree with 4 diffusers 90° elbow union and 500 mm extension	-	-	-	T.OL.P05.55.01	T.OL.P05.55.01	T.OL.P05.55.01
Flexible cannon	T.GCF.45.01	T.GCF.50.01	T.GCF.50.01	-	-	-
Vertical cannon	-	-	-	T.GCV.000.01	T.GCV.000.01	T.GCV.000.01
Vertical cannon with 90° elbow union and 800 mm extension	-	-	-	T.GCV.P08.01	T.GCV.P08.01	T.GCV.P08.01
Tobacco cannon	T.GC.00.45T.02	-	-	-	-	-
Tobacco cannon with 600 mm extension	T.GC.P06.45.02	-	-	-	-	-
Tobacco cannon (multiple distribution device)	-	T.GC.00.50T.02	T.GC.00.50T.02	T.GC.00.55T.01	T.GC.00.55T.01	T.GC.00.55T.01
Tobacco cannon (multiple distribution device) with 600 mm extension	-	T.GC.P06.50.02	T.GC.P06.50.02	-	-	-
Tobacco cannon (multiple distribution device) with 90° elbow and 500 mm extension	-	-	-	T.GC.P05.55.01	T.GC.P05.55.01	T.GC.P05.55.01
Rotating group with electric control device	T.GIR.E.175T	T.GIR.E.175T	T.GIR.E.175T	T.GIR.E.250T	T.GIR.E.250T	T.GIR.E.250T
2 fishtail spray head with 3 wide sector	T.2V.45T.02	-	T.2VS.55T.02	T.2VS.55T.02	T.2VS.55T.02	-
2 fishtail spray head with 4 sector	-	T.2V.50T.10.01	T.2V.50T.15.01	T.2V.55T.01	T.2V.55T.01	T.2V.55T.01
4 fishtail spray head	-	T.4V.50T.10.02	T.4V.50T.15.02	T.4V.55T.02	T.4V.55T.02	T.4V.55T.02
6 fishtail spray head	-	-	-	T.6V.55T.02	T.6V.55T.02	T.6V.55T.02
Potatoes spray head with 90° elbow union	-	-	-	T.PT.55T.02	T.PT.55T.02	T.PT.55T.02
Tomatoes spray head with 90° elbow union	-	-	-	T.PM.55T.02	T.PM.55T.02	T.PM.55T.02
2 hands + 2 cannons spray head	TC.2M2C.45T.01	TC.2M2C.50T.01	TC.2M2C.50T.01	TC.2M2C.55T.01	TC.2M2C.55T.01	TC.2M2C.55T.01
2 hands + 2 flexible cannons spray head	TCF.2M2C.45T02	TCF.2M2C.50T02	TCF.2M2C.50T50	TCF.2M2C.55T02	TCF.2M2C.55T02	TCF.2M2C.55T02
2 hands + 4 flexible cannons spray head	TCF.2M4C.45T02	TCF.2M4C.50T02	TCF.2M4C.50T50	TCF.2M4C.55T02	TCF.2M4C.55T02	TCF.2M4C.55T02
2 hands + 4 cannons spray head	TC.2M4C.45T.01	TC.2M4C.50T.01	TC.2M4C.50T.50	TC.2M4C.55T.01	TC.2M4C.55T.01	TC.2M4C.55T.01

UMAPT081

It is easy to understand how it is possible, making smaller drops of one drop, to double, triplicate or quadruplicate its initial coverage. It is also easy to understand how, having a certain quantity of water at our disposal, the coverage possibilities are different and strictly bound to the capacity of "pulverization" of the machine employed.

The diameter of the produced drops is of fundamental importance and can be explained with the following physical observation: "1 lt. of pulverized liquid (1 dm<sup>3</sup>) may cover a surface of 1 hectare with a density of 20 drops per cm<sup>2</sup>, if their diameter is 100 microns (pneumatic sprayers). If this diameter increases up to 300 microns (air-assisted) the number of drops per cm<sup>2</sup> will only be 0,7".

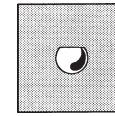

UMAP078

1 l/ha with Ø 100 microns = 20 drops per cm<sup>2</sup> (LOW VOLUME)

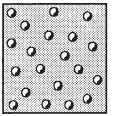

UMAP079

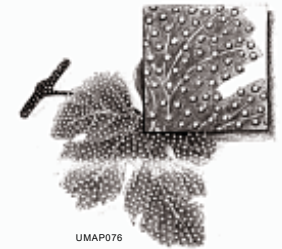

UMAP076

1 l/ha with Ø 300 microns = 0,7 drops per cm<sup>2</sup> (NORMAL VOLUME)

We recall to you that the **QUANTITY OF AGROCHEMICAL PRODUCT** to be distributed per **HECTARE**, depending on the cultivation to be treated, **REMAINS UNCHANGED**, independently from the type of machine employed. It can be deduced from the tables printed on the product packages and from the quantity of water used for "that" surface in the previous treatments.

**WITH THE SAME VOLUME OF WATER**

TANK CAPACITY litres 1000	MACHINE USED	PULVERIZATION SYSTEM	PRODUCT EMPLOYED	SURFACE TREATED	MIXTURE CONCENTRATION
	AIR-ASSISTED	NORMAL VOLUME	Kg 3	1 ha	ONCE OR NORMAL = 300 g/100 lt.
	PNEUMATIC SPRAYER	LOW VOLUME	Kg 6	2 ha	TWICE OR DOUBLE = 600 g/100 lt.
	PNEUMATIC SPRAYER	LOW VOLUME	Kg 12	4 ha	4 TIMES OR QUADRUPLE = 1200 g/100 lt.

UMAPT081

**11 ATOMIZER ADJUSTMENT 11**

**11.1 - BASIC INFORMATION: "LOW VOLUME"**

It is commonly known that to use agrochemical products, in spite of the development of appropriate instruments, we have always been obliged to use water as the indispensable means, to obtain an adequate cultivation coverage. Its "pulverization" in very small drops is the only way to complete a homogeneous distribution of small quantities of active principles over wide vegetation surfaces.

The measuring unit of the diameter of drops obtained with pulverization is the MICRON, which is the thousandth part of a millimeter:

$$MICRON = \frac{1 \text{ mm}}{1000}$$

The traditional system to obtain this transformation of the water, usually called "NORMAL VOLUME" consists in forcing water at high pressure through one or more jets of a very small diameter. By this principle knapsack pumps, pressure pumps and diaphragm or piston pumps, used for hydraulic sprayers and air assisted are being manufactures.

Another system of pulverization was then developed, based on the "Venturi tube" principle. It consists in creating a very strong air stream, directing it into a tube and letting it out through a suitable narrow passage.

The water, without pressure, is introduced into the center of this narrow passage where it is pulverized, as a consequence of the air speed. The application of this principle is the essential and binding condition for the manufacture of pneumatic sprayers.

Appropriate and specific technical checks have brought to light the considerable difference in the diameters of the drops produced by these two "pulverization" systems. In the "normal volume" (turbosprayers) 85% of the drops have a diameter of 250/300 microns, and this value cannot be reduced even increasing the working atmospheres. The second system (pneumatic sprayers) creates a cloud of water where 90% of drops have a diameter of 50-100 microns.

This considerable pulverization difference is fundamental! It allows the pneumatic sprayers, using an equal volume of water, to have a remarkably higher coverage with respect to the traditional pumps. In other words, the sprayers can cover the same vegetation surface treated by the "normal volume" machines, but with a considerably lower quantity of water, i.e. with a "LOW VOLUME" of water.

To figuratively express this concept, let us consider water drop "A", represented, for easier illustration as a square with 6 cm. sides.

The contact side is 6 cm.

From the same square "A" we have obtained 4 squares with 3 cm. sides, thus obtaining a contact line of 12 cm.

Once again from square "A" we have obtained 9 squares with 2 cm. sides, thus bringing the contact line to 18 cm.

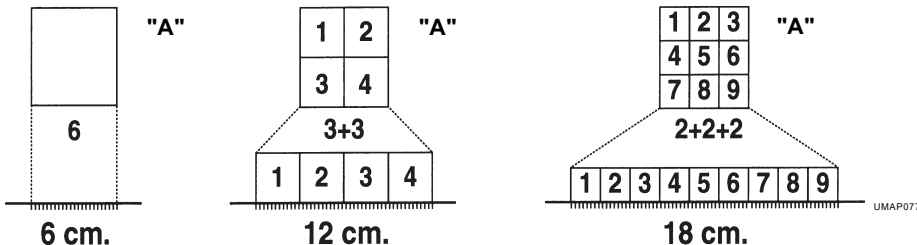

**6.2 - ELBOWS FOR THE DISTRIBUTION DEVICES**

The elbow unions support the distribution devices and connect them to the fan. All outlet openings of the trailer-mounted sprayer are situated in the back part of the machine, in a downward vertical position, unless there are additional parts, considered standard, which modify their position.

COMPLETE RANGE	BLITZ 45T-50T	BLITZ 55T-55TS-55TE- (50T1500*)
Fan outlet opening	inside diameter 175 mm	inside diameter 250 mm
BASIC MODEL OF THE RANGE		
machine delivered	WITH 90° ELBOW	WITHOUT ELBOW
Outlet opening	HORIZONTAL back	VERTICAL back

UMS5T151



The use and maintenance manual of each distribution device gives the necessary type of elbow union and the assembling instructions.

**7 ACCESSORIES 7**

**7.1 - FILLING PIPING**

This piping is complete with a coupling union and a filter with foot valve for suction and is used to tank. It must be screwed onto the suction union of the P4 pump instead of the tap with chain.



The assembling should ALWAYS be carried out when the "P3" tap lever is in "C" position.



Before use, check the seal and see whether the foot valve is working correctly by pouring some water into the piping.

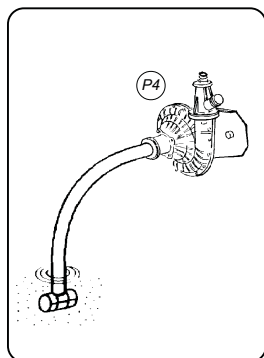
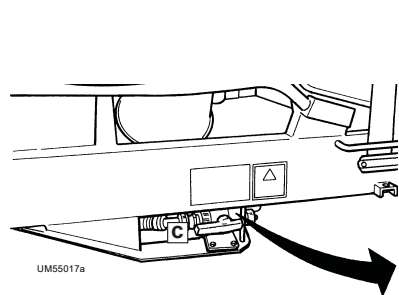

**7.2 - ROTATING GROUP WITH ELECTRIC CONTROL**

It is an accessory used to modify the spraying direction. It may be used with only a few types of distribution devices.



All indications and instructions can be found in the use and maintenance manual of the distribution devices with which this group may be used.

**7.3 - ADDITIONAL AGITATION PUMP**

All indications and instructions can be found in the use and maintenance manual supplied with this optional accessory.

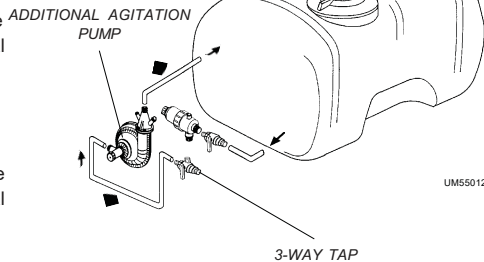

**7.4 - MECHANICAL BLADE AGITATOR**

All indications and instructions can be found in the use and maintenance manual supplied with this optional accessory.

**9 MIXTURE AGITATION 9**

Inside the tank a hydraulic and a pneumatic circuit allows a double system of agitation. When using products with marked foam effect, it is possible to exclude the pneumatic circuit by closing the piston cock on the tank. When opening it again, check that the air outlet holes are not clogged.



Before beginning the treatment it is essential to agitate the mixture in the tank recycling its volume for the time necessary to make it homogeneous.



- The agitation should take place with the pressure adjustment knob cocks (P5) and the piston cock on the tank completely open.
- This operation is essential to obtain a uniform distribution of the active principle over the whole vegetation surface to be treated.

In case of a short break in the treatment, keep the agitation running till it is re-started. In case of a long break, before re-starting duly agitate the mixture left in the tank.

**10 DISCHARGE OF THE HYDRAULIC CIRCUIT 10**



- Stop the tractor and take the key out of the control panel.
- Wear protective clothing and accessories to avoid risks of contamination by contact or inhalation of the mixture.
- Discharge the circuit in an area suitably prepared and adequately equipped for collecting the washing liquid.

This operation is carried out by means of the 3-ways tap (P3):

1. remove the cap with chain while the lever is in position "a".
2. turn the lever to position "b".

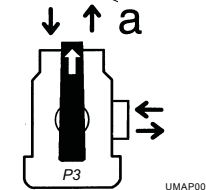
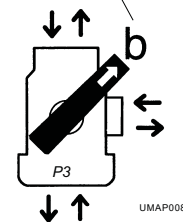



At the end of discharge, screw the cap with chain back in and turn the lever to position "a".

tap with chain.

- Turn the lever of the 3-way tap to **position "a"** and **re-open** the adjustment cock (P5) by turning the knob counter-clockwise.



15. Carefully screw the tank cover on, maintain the agitation, and bring the operative unit to the cultivation to be treated

ON TREATMENT SITE:

- 

**Stop the tractor and take the key out of the control panel. CHECK THAT THE FAN HAS STOPPED.**
- Engage the fan in the gearbox: follow the instructions given in point 8.1, **pushing** the front body instead of pulling it.
- Re-fit the movable cover protecting the release.
- Start the tractor. Engage the PTO and carry out another agitation; keeping the PTO at 500 rpm.
- START THE TREATMENT.

**8 FILLING PROCEDURES 8**

FILLING OPERATION SHOULD BE CARRIED OUT WHEN THE MACHINE IS ON A FLAT SURFACE. ON THE TREATMENT PLACE, BEFORE THIS OPERATION, PREPARE THE QUANTITIES OR THE MIXTURES TO BE POURED INTO THE TANK.

-  THE PUMP MUST NEVER WORK WITHOUT AND FLUID.
-  IT IS ALWAYS NECESSARY TO USE PERSONAL PROTECTIVE MEANS.



**8.1 - INTRODUCTION - USE OF THE FAN RELEASE**

-  The tank filling and the mixture agitation outside the cultivations cannot be done without the help of the fan release.

The release, with front restrain, fitted to the fan shaft, is situated in the machine front part, under the protection guard and can be reached through the appropriate movable cover.

**Releasing the fan for filling operation**

EXECUTION:

- Bring the atomizer on the filling site.
- 

**Stop the tractor, take the key out of the control panel and check that the fan has stopped.**

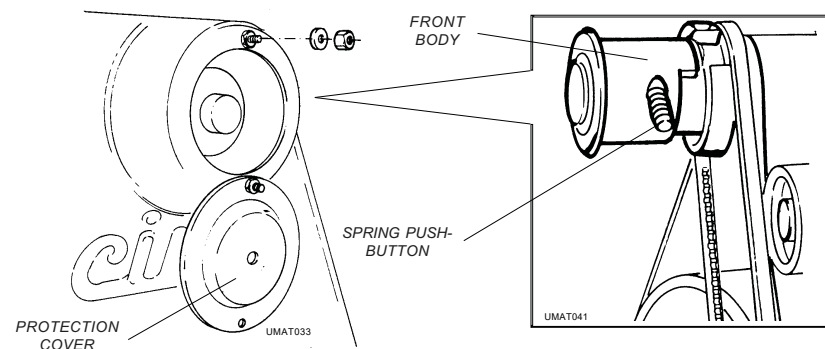
Remove the P5-P6-P7 adjustment group by taking away the supporting bracket.  
 Press the spring push-button till the end and pull the front body until it is again released outwards. The released body should turn free: then the pump runs and the fan is excluded.  
 Re-fit the protection cover by fixing it with the 2 appropriate screws.  
 Start the tractor and carry out the filling operation (see filling instructions).



### 8.2 - BY INLET



The orifice of the inlet piping should never come into contact with the insecticide mixture: IT MUST ALWAYS BE KEPT AT A CERTAIN HEIGHT OVER THE TANK OPENING AND MUST BE EQUIPPED WITH A NON RETURN VALVE.



THE PUMP MUST NEVER RUN WITHOUT FLUID.

EXECUTION:

1. Release the fan: follow the instructions given at point 8.1.
2. Turn the lever of the 3-ways tap (P3) on "a" position..
3. Shut the cocks of the 2-ways distributor:
  - a. if it is handoperated (P8), put them in horizontal position;
  - b. if it is electric (E7), put the release switches on "OFF".
4. Completely open the adjustment tap (P5), by turning the knob counter-clockwise.
5. Pour water into the tank (approx 1/3 of its capacity).

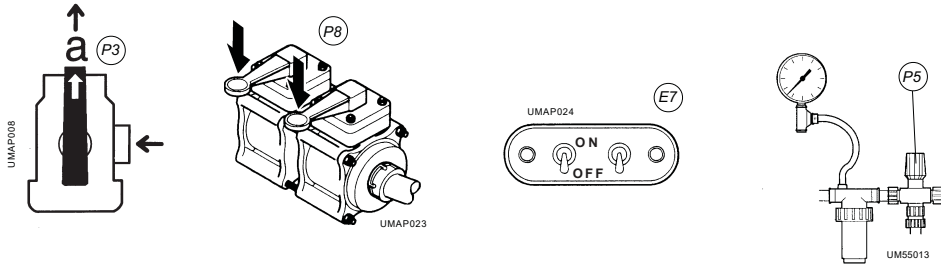

6. Start the tractor, respecting the safety norms. Engage the PTO and keep it at 500 rpm.
7. Pour the necessary quantity of insecticide and the possible water used for washing the product packages and the tools used for preparation.
8. Finish filling and carefully screw the tank cover.
9. Keep on agitating the mixture in the tank and bring the operative unit in the cultivation to be treated.

ON TREATMENT SITE:

10. Disengage the PTO.

11. **Stop the tractor and take the key out of the control table.**

**CHECK THAT THE FAN HAS STOPPED.**

12. Engage the fan in the gearbox: follow the instructions given at point 8.1, **pushing** the front body instead of pulling it.
13. Re-fit the movable cover protecting the release.
14. Start the tractor. Engage the PTO and carry out another agitation, keeping the PTO at 500 rpm.  
START THE TREATMENT.

### 8.3 - WITH FILLING PIPING



Before use, check for the foot valve good running and seal, by pouring some water into the piping.



THE PUMP MUST NEVER RUN WITHOUT ANY FLUID.

EXECUTION:

1. Release the fan (see point 8.1).
2. Turn the lever of the 3-ways tap(P3) on **position "c"**.
3. Shut the cocks of the 2-ways distributor:
  - a. if it is handoperated (P8), put them in horizontal position;
  - b. if it is electric (E8), put the release switches on "OFF".
4. Completely **open** the adjustment cock (**P5**), by turning the knob counter-clockwise.

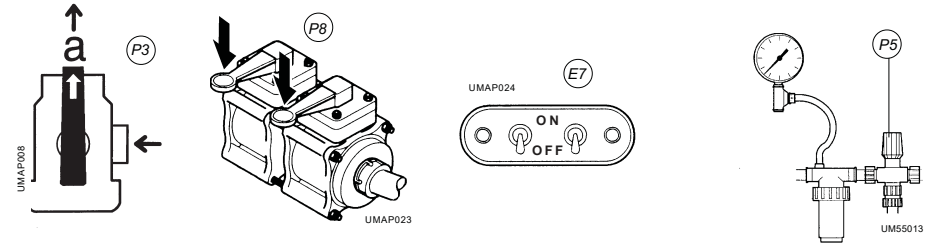

5. Screw the filling piping on the suction union of the pump (P4), instead of the tap with chain.
6. Plunge the filter into the water to be loaded.



**The filter must always be under the water level. The piping never must exceed the pump suction point and never must create a marked elbow appear.**

7. Put the lever of the 3-ways tap(P3) on **position "a"**.
8. Pour 15/20 lt. of water into the tank, to FILL the PIPING and prime the centrifugal pump.
9. Start the tractor, respecting the safety norms. Engage the PTO and keep it at 500 rpm.
10. By turning the lever of the 3-ways tap (P3) on **position "c"** the tank filling begins through the return piping (T3).
11. Pour the necessary quantity of insecticide and the possible water used to wash the product packages and the tools used for preparation.
12. Finish loading and **shut** the adjustment cock (**P5**) by turning the knob clockwise.

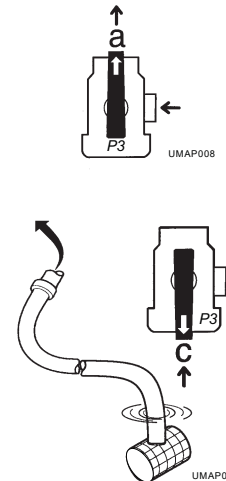

13. Remove the filling piping from the pump and re-fit the