

**Sez. 11 (⌘)**  
Comando elettrico  
*Remote control*

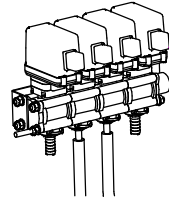

**Sez. 12 (⌘)**  
4 Elettrovalvole  
*4 Electrovalves*

**Sez.22 (⌘)**  
Tubazione Riempimento  
*Filling pipe*

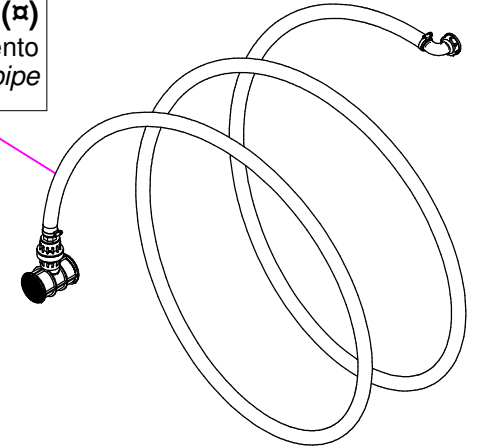

**Sez. 12 (⌘)**  
Gruppo Elettrovalvole  
*Electrovalves assembly*

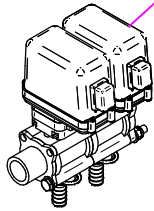

**Sez.06E (⌘)**  
Elettrovalvola Regolazione Pressione  
*Solenoid Valves Regulation Pressure*

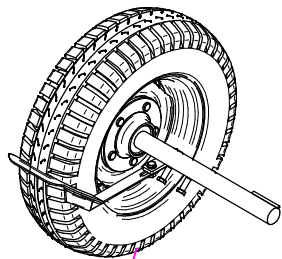
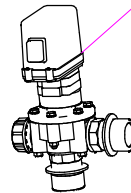

**Sez. 14 (⌘)**  
Coppia di ruote  
*Wheels*

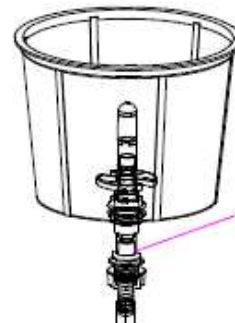
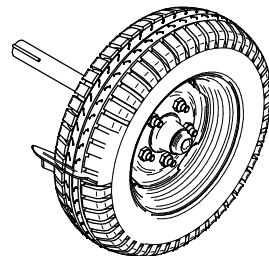

**Sez.02E (⌘)**  
Lava barattoli  
*Container Washing Device*

**Sez.11A (⌘)**  
Kit EPA  
*EPA Kit*

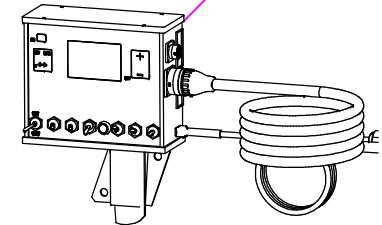

**(⌘) A richiesta / Optional Devices**

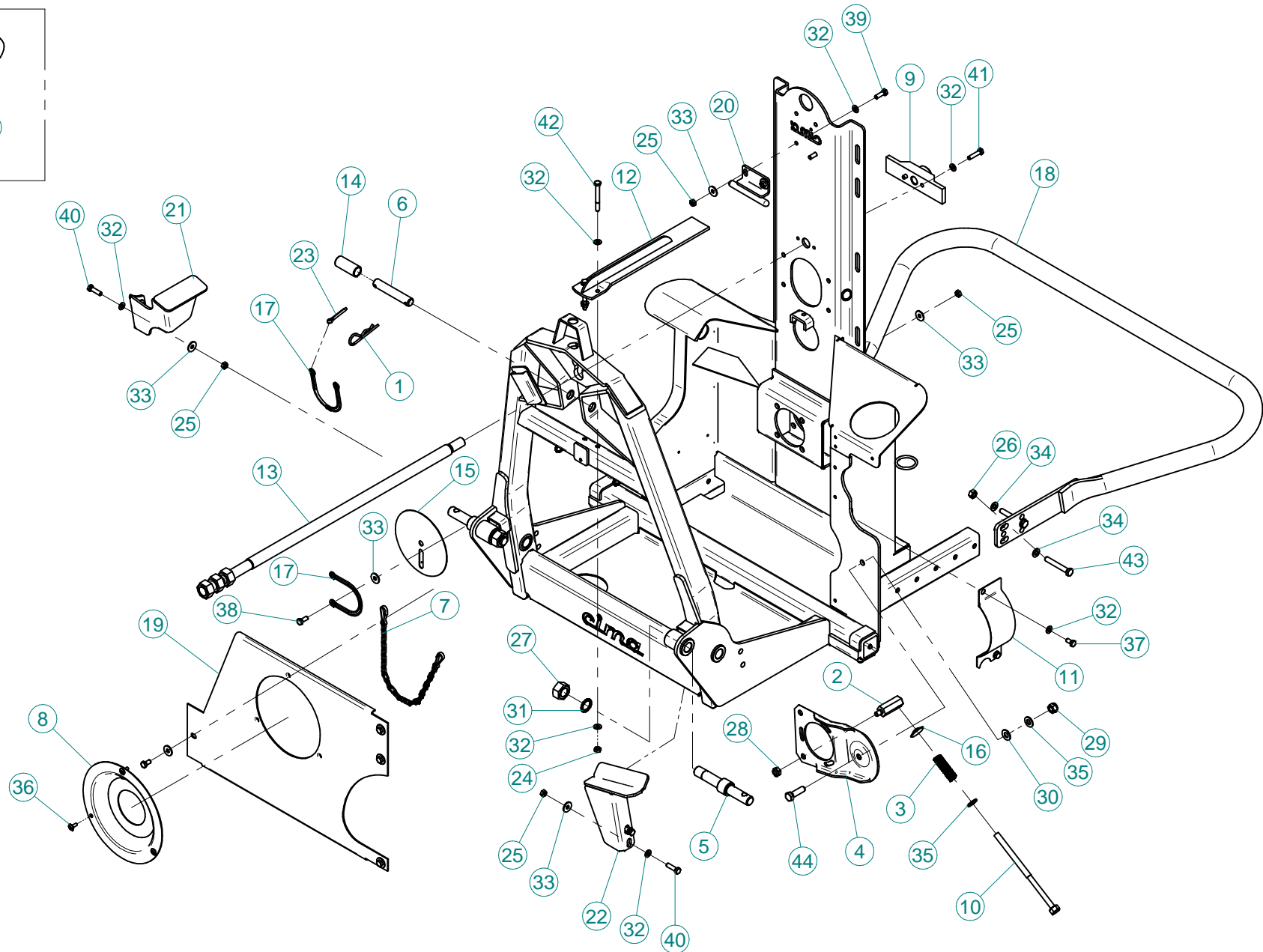
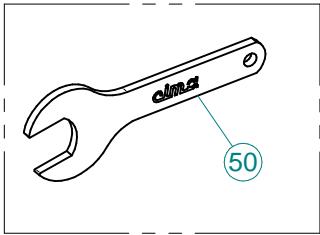

N°	Doc. Number	Titolo	Title	Q.tà	N°	Doc. Number	Titolo	Title	Q.tà
1	X00.100.004	COPIGLIA A MOLLA D.4	CLIP D.4	1	41	XTE.008.035T	VITE TE M8X35 5739 ZINC.	BOLT TE M8X35 5739	2
2	X02.963.100	PERNO TENDICINGHIA POMPA CD 32	PIN BELT STRETCHER PUMP CD 32	1	42	XTE.008.070	VITE TE UNI 5737-65 M8x70-8.8	SCREW TE UNI 5737-65 M8x70-8.8	2
3	X02.964.000	MOLLA PER POMPA CD 32	CD 32 PUMP SPRING	1	43	XTE.010.070T	VITE TE UNI 5739-65 M10x70-8.8	SCREW TE UNI 5739-65 M10x70-8.8	4
4	X02.978.000SX	SUPPORTO POMPA TIPO NUOVO	BRACKET	1	44	XTE.012.040T	VITE TE UNI 5739-65 M12x40-8.8	SCREW TE UNI 5739-65 M12x40-8.8	1
5	X04.064.001	SPINOTTO SOLLEVATORE	PIN POWER LIFT	2					
6	X04.076.000	SPINOTTO 3° PUNTO D.19	PIN	1					
7	X04.111.045	CATENELLA cm.45 CON MOSCHETTONI	CHAIN	1					
8	X20.434.000	COPERCHIO FISSAGGIO CONTROCUFFIA	FIXING COVER	1					
9	X20.737.102	PIATTO PER TIRANTE M20	PLATE FOR ROD M20	1					
10	X20.738.000	TENDICINGHIA M12 PER POMPA CD 32	LEVER M12 FOR BELT STRETCHER	1					
11	X20.743.000	LAMIERA PROTEZIONE PULEGGIA	SAVE PULLEY PLATE	1					
12	X20.744.000	PIASTRA FISSAGGIO SERBATOIO	FIXING TANK PLATE	1					
13	X20.754.102	TIRANTE	TIE ROD	1					
14	X20.778.000	BOCCOLA 3° PUNTO PER PLUS	BUSH	1					
15	X20.861.000	DISCO PROTEZIONE DISINNESTO	DISINGAGED PROTECTION DISK	1					
16	X21.113.000	RONDELLA BOMBATA D. 12x36	WASHER D. 12x36	1					
17	X21.183.000	STRISCIA FERMATAPPI	CAP FASTENER BEND	2					
18	X40.000.000	CERCHIO DI PROTEZIONE	BUMPER	1					
19	X40.227.002	FACCIATA PROTEZIONE	PROTECTION PLATE	1					
20	X40.403.000	FERMO PER SERBATOIO	TANK BLOCK	1					
21	X50.395.200	STAFFA DX APPOGGIO SERBATOIO Lt.300	300 Lt. TANK RIGHT SUPPORT	1					
22	X50.396.200	STAFFA SX APPOGGIO SERBATOIO Lt.300	300 Lt. TANK LEFT SUPPORT	1					
23	XCP.006.040I	COPIGLIA D.6 L=40 INOX 1336	SPLIT PIN D.6 L=40 INOX 1336	1					
24	XD0.08.5588G	DADO M8 6S PG	M8 6S BIG LEAD NUT 5588	2					
25	XD0.08.5588G	DADO M8 6S PG 5588 ZINC.	M8 6S BIG LEAD NUT 5588	7					
26	XD0.10.5587G	DADO M10 6S PG 5587 ZINC.	M10 6S BIG LEAD NUT 5587	4					
27	XD0.22.5588F	DADO M22 6S PF 5588 ZINC.	M22 6S FINE LEAD NUT 5588	2					
28	XDA.010.0BG	DADO AUTOBLOCCANTE M10	SELF LOCKING NUT M10	1					
29	XDA.012.0AG	DADO AUTOBLOCCANTE M12	NUT M12	1					
30	XMT.012.000	MOLLA A TAZZA D. 12	WASHER D.12	1					
31	XRD.022.000	RONDELLA DENTELLATA EST.D.22 ZINC.	TAB WASHER D.22	2					
32	XRP.008.000	RONDELLA PIANA D.8 6592 ZINC.	8 D. FLAT WASHER	14					
33	XRP.008.024	RONDELLA PIANA F.LARGA D.8X24 ZINC.	WASHER D.8X24	12					
34	XRP.010.000	RONDELLA PIANA D.10 6592 ZINC.	WASHER Ø 10	8					
35	XRP.012.000	RONDELLA PIANA Ø12	WASHER Ø12	2					
36	XTCC.06.16	VITE TESTA A CROCE M6x16	CROSS SLOTTED SCREW M6x16	3					
37	XTE.008.016T	VITE TE UNI 5739-65 M8x16-8.8	SCREW TE UNI 5739-65 M8x16-8.8	6					
38	XTE.008.020T	VITE TE UNI 5739-65 M8x20-8.8	SCREW TE UNI 5739-65 M8x20-8.8	1					
39	XTE.008.025T	VITE TE M8X25 5739	BOLT TE M8X25 5739	2	N°	Doc. Number	Titolo	Title	Q.tà
40	XTE.008.030T	VITE TE M8X30 5739 ZINC.	BOLT TE M8X30 5739	4	50	X40.237.000	CHIAVE M32	SPANNER M32	1

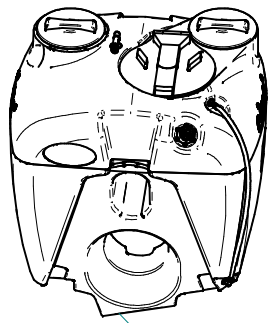

X21.373.001

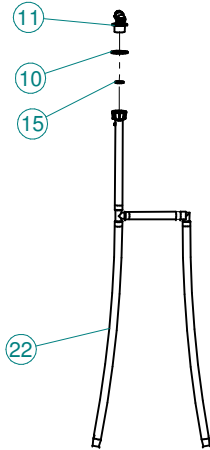

22

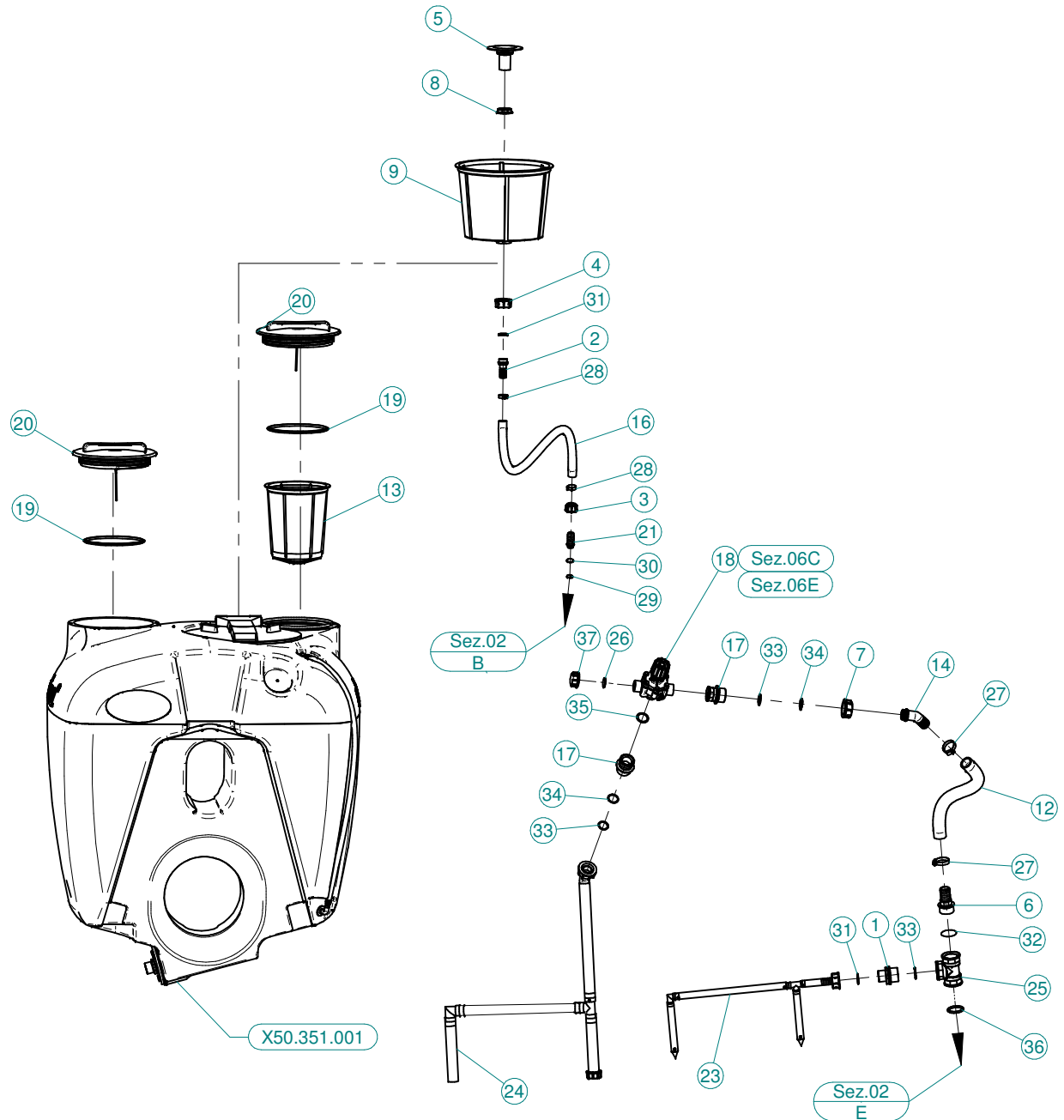

N°	Doc. Number	Titolo	Title	Q.tà
1	X00.045.012	RIDUZIONE 1" 1/4 M - 1" M	1" 1/4 M - 1" M REDUCER NIPPLE	1
2	X00.055.022	RACCORDO DIRITTO P.G. D.19	STRAIGHT HOSE R.H. D.19	1
3	X00.055.045	GIRELLO 3/4" GAS ALTO	3/4" GAS FLY NUT	1
4	X00.055.24.2	GIRELLO 1" GAS	1" FLY NUT	1
5	X00.131.000	PRESA ANTIVORTICE 1"	1" VORTIX DAMPER DRIVE	1
6	X00.423.000	RACCORDO DIRITTO PG 30 FIL.1" 1/4 GAS	MALE CONNECTOR RH 30 1" 1/4 GAS	1
7	X00.493.000	GIRELLO 1" 1/4 GAS	1" 1/4 FLY NUT	1
8	X00.542.000	GHIERA 1"	NUT 1"	1
9	X00.646.010	FILTRO A TAZZA D.302x254 FORATO	BASKET FILTER D.302x254	1
10	X02.032.000	GUARNIZIONE Ø 26x40 SP. 2	GASKET Ø 26x40 SP. 2	1
11	X02.135.100	VALVOLA A PISTONCINO COMPLETA CORTA	COMPLETE SHORT PISTON VALVE	1
12	X02.238.042	TUBO SPIRALATO ø30 L=420 mm	HOSE ø30 L=420 mm	1
13	X02.298.000	FILTRO A TAZZA D.204	BASKET FILTER D.204	1
14	X02.339.000	RACCORDO CURVO A 45° CON P.G. D.30	45° HOSETAIL	1
15	X02.349.000	GUARNIZIONE PIANA D.17X23X3	17X23X3 FLAT GASKET (G4000B)	1
16	X02.372.080	TUBO SPIRALATO ø19 L=800mm	HOSE ø19 L=800mm	1
17	X02.374.000	RIDUZIONE M/F 1" F / 1"1/4M	M. / F. 1" F / 1"1/4M REDUCTION	2
18	X02.447.300	VALVOLA DI REGOLAZIONE A 3 VIE	THREE WAY REGULATION VALVE	1
19	X02.476.000.A	GUARNIZIONE PER COPERCHIO Ø255	GASKET	2
20	X02.476.100	COPERCHIO FILETTATO D.255 CON FILO	THREADED LID D.255 WITH ROPE	2
21	X21.184.000	RACCORDO DIRITTO 3/4" P.G.20	STRAIGHT UNION 3/4" R.H.20	1
22	X21.380.000	AGITATORE PNEUMATICO 300 Lt.	PNEUMATIC AGITATOR	1
23	X21.393.000	TUBI POLIETILENE AGITAZIONE DA POMPA	MIXING HOSE FROM PUMP	1
24	X21.394.200	TUBI POLIETILENE AGITAZIONE DA REGOLATORE	MIXING PIPES FROM REGULATION VALVE	1
25	X24.075.000	RACCORDO A T 1 1/4" GAS F.	1 1/4" FEMALE T THREADED UNION	1
26	X24.100.000	GUARNIZIONE PIANA D.30x3 PER TAPPO D. 1"	GASKET D.30 x 3	1
27	XF0.025.040I	FASCETTA A VITE 25/40 W4 INOX	STAINLESS STEEL CLIP	2
28	XFC.023.5.025	FASCETTA COBRA SLO30761	KOBRA CLAMP SLO30761	2
29	XOR.000.117	OR D.13,1X2,62	13.1X2.62 O-RING GASKET	1
30	XOR.000.121	OR D. 15,88 x 2,62	15,88 x 2,62 O-RING GASKET	1
31	XOR.000.132	OR Ø23,81 x 2,62	23,81 x 2,62 O-RING GASKET	2
32	XOR.000.144	OR Ø39,69x3,53	O-RING Ø39,69x3,53	1
33	XOR.003.106	OR Ø26.65x2.62	O-RING Ø26.65x2.62	3
34	XOR.003.112	OR Ø28,24x2,62	O-RING D.28,24x2,62	2
35	XOR.004.118	OR Ø 29,75 x 3,53	29,75 x 3,53 O-RING GASKET	1
36	XOR.006.162	OR Ø40,65 x 5,34	O-RING GASKET 40,65 x 5,34	1
37	XTF.001.000	TAPPO 1"	PACKING	1

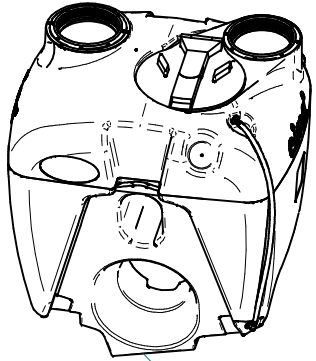

X50.351.001

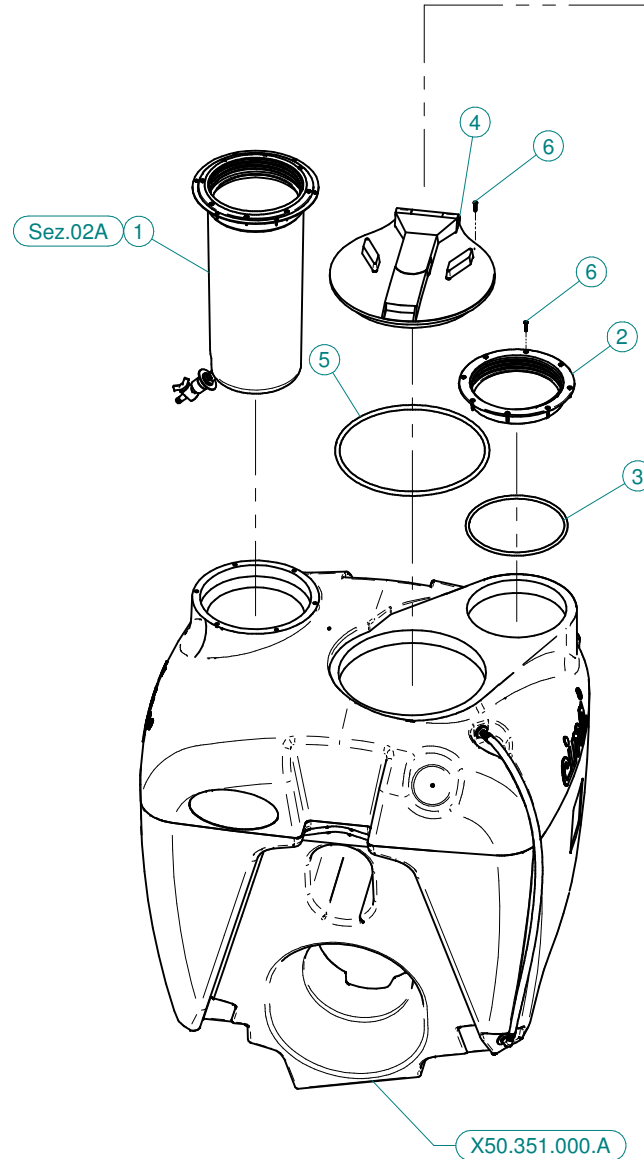

# X20.787.000

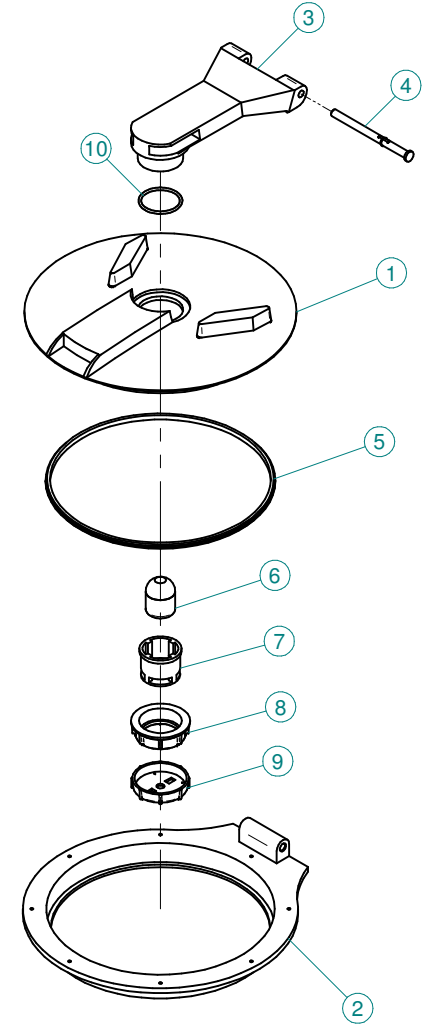

## X50.351.001

N°	Doc. Number	Titolo	Title	Q.tà
1	K.LAV.03.P16	KIT SERBATOIO SUPPLEMENTARE LAVAMANI	KIT HAND-CLEANER TANK	1
2	X02.477.000	ANELLO FILETTATO Ø255	THREATED RING Ø 255	1
3	X02.477.100.A	GUARNIZIONE PER ANELLO Ø255	GASKET	1
4	X20.787.000	COPERCHIO RIBALTABILE 180°	HINGED TANK LID	1
5	X20.787.000.L	GUARNIZIONE	GASKET	1
6	XTAS.04.2.025I	VITE AUTOFILETTANTE 4,2 x 25	SELFTHREATED SCREW 4,2 x 25	14

## X20.787.000

N°	Doc. Number	Titolo	Title	Q.tà
1	X20.787.000.A	DISCO DI CHIUSURA	GRIPPING PLATE	1
2	X20.787.000.B	ANELLO BASE	BASE RING	1
3	X20.787.000.C	BRACCIO	ARM	1
4	X20.787.000.D	PERNO	PIN	1
5	X20.787.000.E	GUARNIZIONE SAGOMATA	SHAPED GASKET	1
6	X20.787.000.F	SFERA GALLEGGIANTE	FLOATING BALL	1
7	X20.787.000.G	CORPO VALVOLA DI SFIATO	BREATHER VALVE	1
8	X20.787.000.H	GHIERA	RING NUT	1
9	X20.787.000.I	TAPPO PER VALVOLA DI SFIATO	CAP FOR BREATHER VALVE	1
10	XOR.000.512	OR Ø 51 x 3,5	51 x 3,5 O-RING GASKET	1



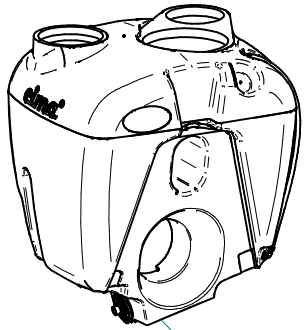

X50.351.000.A

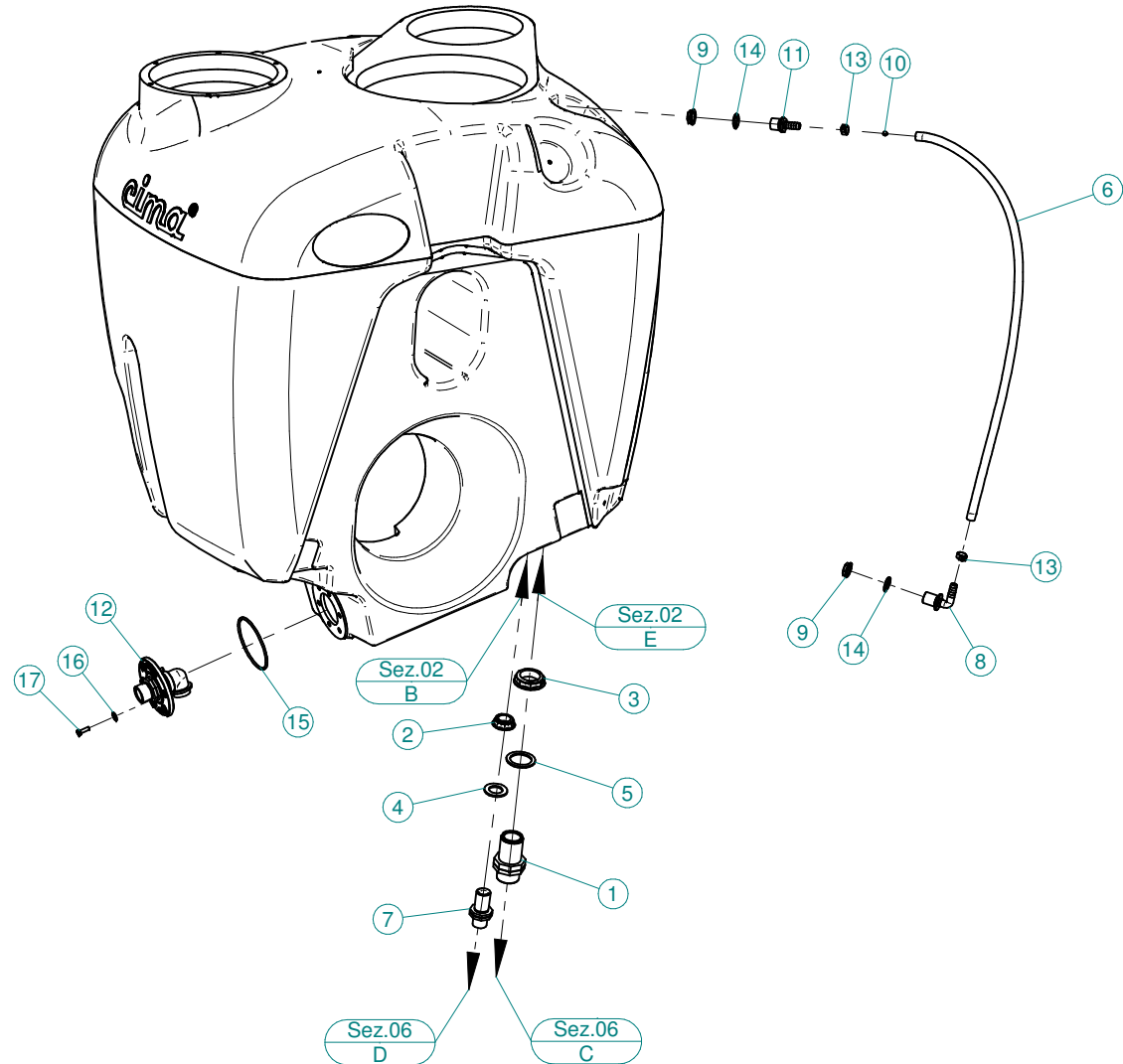

N°	Doc. Number	Titolo	Title	Q.tà
1	X00.345.000	NIPPLO 1" 1/4 + 1" 1/4 GAS	NIPPLE 1" 1/4 + 1" 1/4 GAS	1
2	X00.541.000	GHIERA 3/4"	NUT 3/4"	1
3	X00.543.000	GHIERA 1" 1/4 GAS	NUT 1" 1/4 GAS	1
4	X02.032.000	GUARNIZIONE Ø 26x40 SP. 2	GASKET Ø 26x40 SP. 2	1
5	X02.033.000	GUARNIZIONE PER BOCCHETTONE ASPIRAZIONE	GASKET	1
6	X02.378.085	TUBETTO VITREO Ø 12x16 L=850	HOSE Ø 12x16 L=850	1
7	X02.380.100	NIPPLO 3/4"	NIPPLE 3/4"	1
8	X02.457.000	PORTAGOMMA Ø13 A 90° M. 1/2"	HOSETAIL Ø 13 90° M. 1/2"	1
9	X02.458.000	GHIERA 1/2"	LOCK RING 1/2"	2
10	X02.478.000	SFERA ROSSA Ø 8,5 PER LIVELLO	RED FLOATING BALL Ø 8,5	1
11	X02.482.000	RACCORDO DRITTO P.G Ø 13 M. 1/2"	HOSETAIL MALE THREADED 1/2"	1
12	X40.399.000	PRESA ANTIVORTICE COMPLETA	COMPLETE VORTIX DAMPER	1
13	XFC.016.5.018	FASCETTA COBRA 16,5 - 18	KOBRA CLAMP 16,5 - 18	2
14	XOR.004.081	OR Ø 20,22 x 3,53	20,22 x 3,53 O-RING GASKET	2
15	XOR.004.400	OR D.101,02X3,53	O-RING Ø 101,2x3,53	1
16	XRP.006.018	RONDELLA PIANA F.LARGA D.6X18 ZINC.	WASHER Ø 6x18	6
17	XTE.006.020T	VITE TE M6X20 5739 ZINC.	BOLT TE M6X20 5739	6

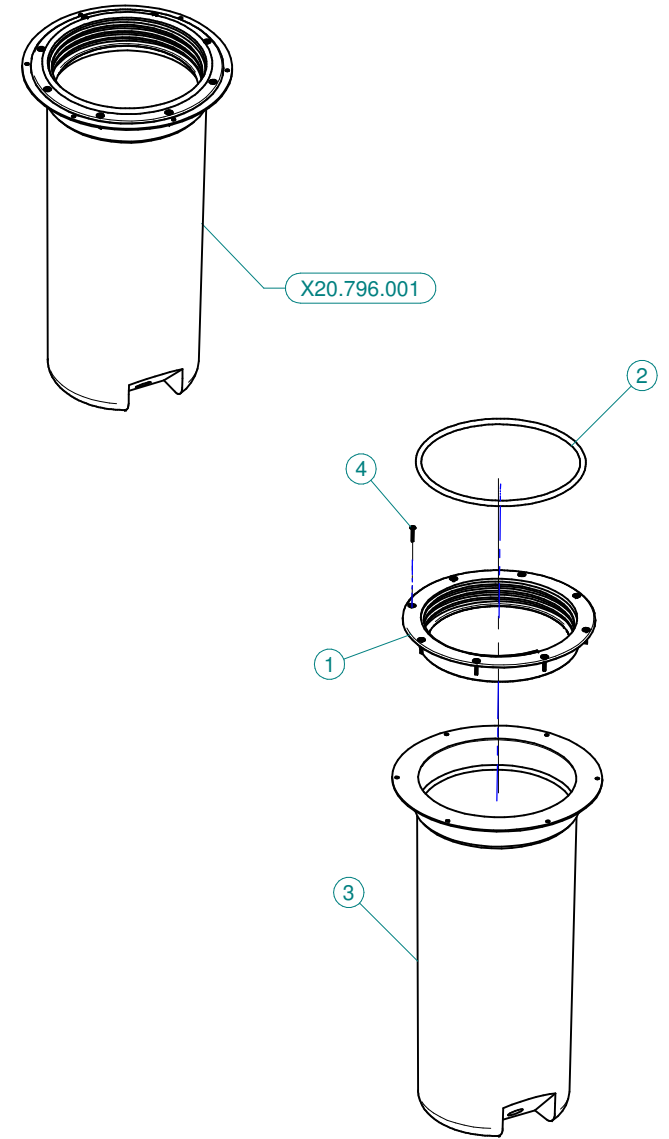
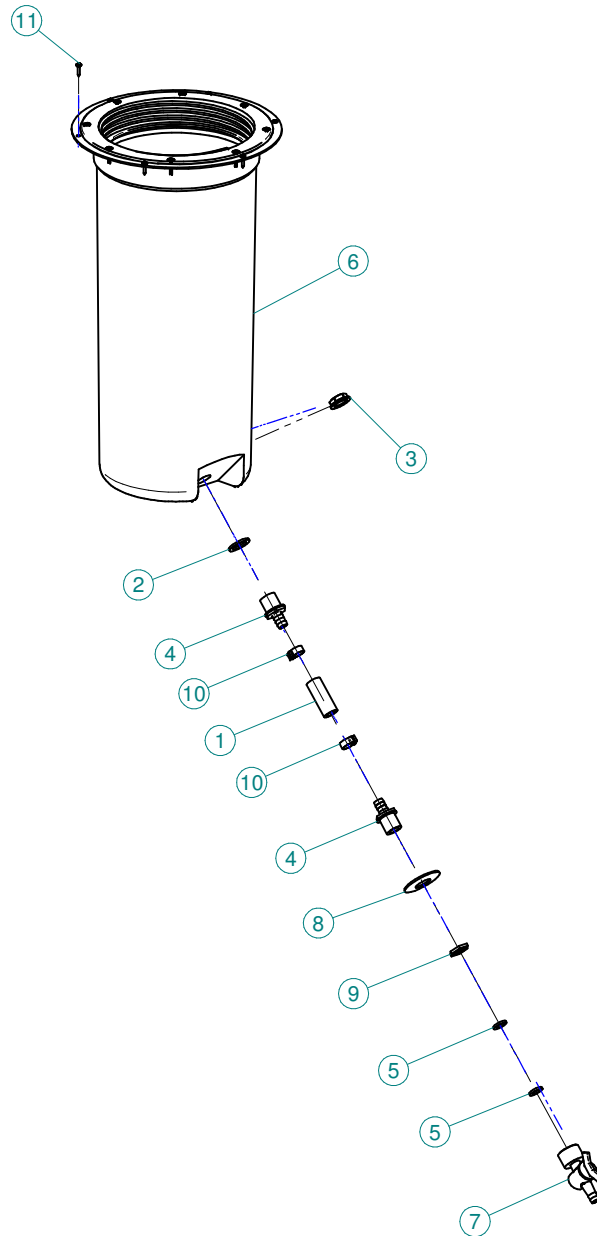
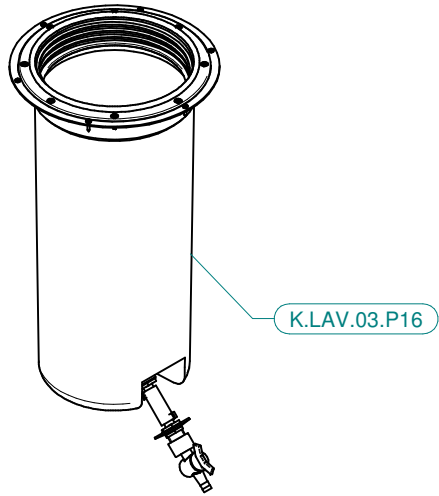

## K.LAV.03.P16

N°	Doc. Number	Titolo	Title	Q.tà
1	X02.220.005	TUBO Ø 13x20 L=51	HOSE Ø 13x20 L=51	1
2	X02.265.000	GUARNIZIONE PIANA Ø 20/30 x 2,5	PLANE GASKET Ø 20/30 X 2,5	1
3	X02.458.000	GHIERA 1/2"	LOCK RING 1/2"	1
4	X02.482.100	RACCORDO DRITTO P.G.Ø 13 M1/2" TAGLIATO	SHORT HOSETAIL MALE THREADED 1/2"	2
5	X20.769.000	GUARNIZIONE Ø 19,2/11,5 X 2,5	GASKET Ø 19,2/11,5 X 2,5	2
6	X20.796.001	SERBATOIO LAVAMANI COMPLETO	HAND-WASHING COMPLETE	1
7	X20.797.000	MINIVALVOLA G 1/2" F.	MINIVALVE G 1/2" F.	1
8	X20.801.000	RONDELLA BOMBATA Ø 22,5 /52,5	SPECIAL WASHER Ø 22,5/52,5	1
9	X24.072.000	GHIERA IN OTTONE 1/2"	BRASS FLY NUT 1/2"	1
10	XFC.016,5.018	FASCETTA COBRA 16,5 - 18	KOBRA CLAMP 16,5 - 18	2
11	XTA.03.9.016I	VITE AUTOFILETTANTE Ø 3,9x16 INOX	SELF-THREADED Ø 3,9x16	6

## X20.796.001

N°	Doc. Number	Titolo	Title	Q.tà
1	X02.477.000	ANELLO FILETTATO Ø255	THREADED RING Ø 255	1
2	X02.477.100.A	GUARNIZIONE PER ANELLO Ø255	GASKET	1
3	X20.796.000	SERBATOIO LAVAMANI Lt.15	HAND-WASHING TANK Lt.15	1
4	XRV.4.0.020	RIVETTO Ø 4 x 20	RIVET Ø 4 x 20	8

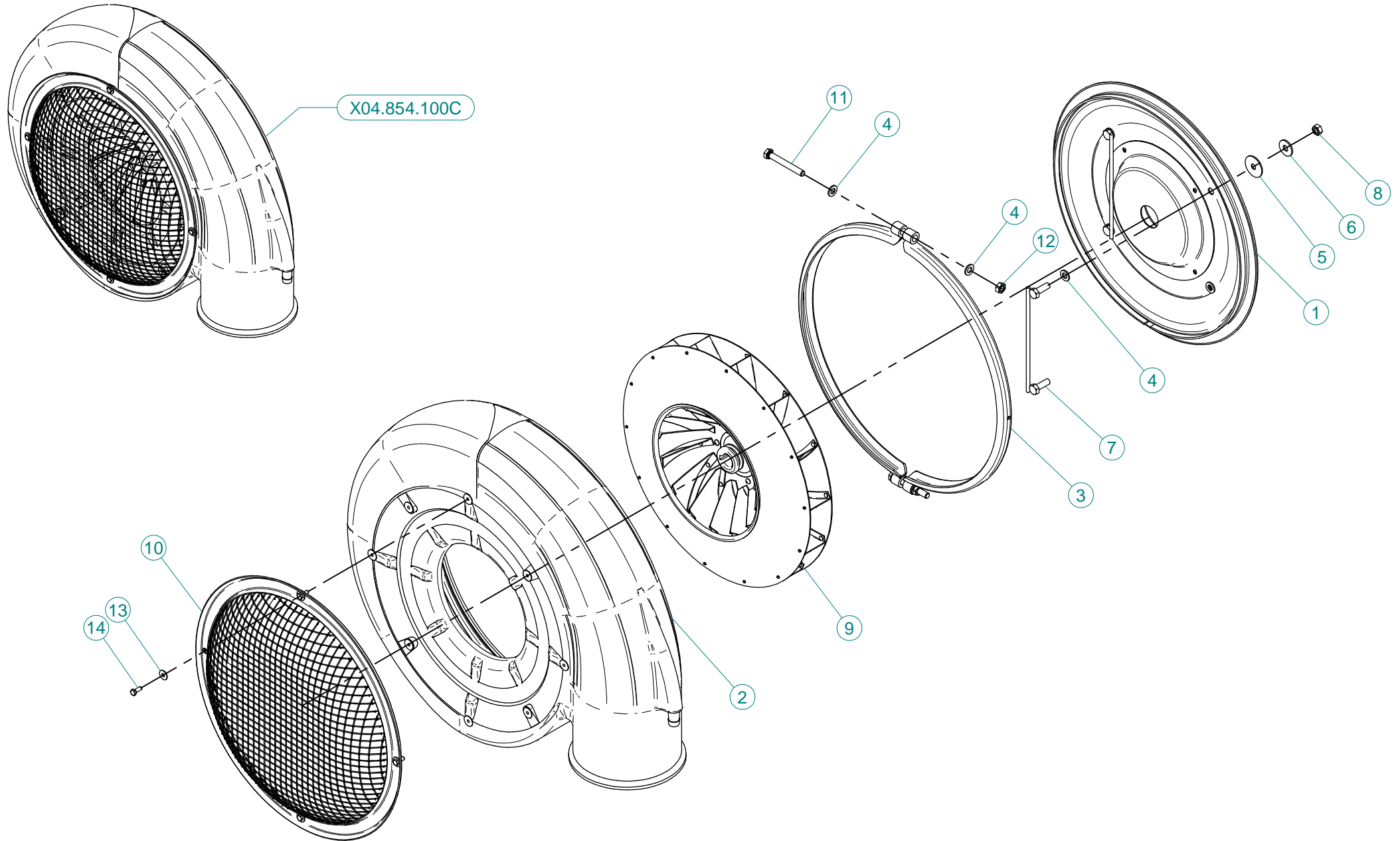

N°	Doc. Number	Titolo	Title	Q.tà	Note
1	X04.853.000	COPERCHIO VENTOLA 45	FAN 45 COVER	1	
2	X04.854.000	CARTER VENTOLA P/T45N	FAN CASING P/T45N	1	
3	X04.874.000.Z	COLLARE D.485	D.485 CLAMP	1	
4	XRP.010.000	RONDELLA PIANA D.10	WASHER D.10	8	
5	XRP.010.040	RONDELLA PIANA D.10 X 40	WASHER D.10 X 40	4	
6	XRP.010.030	RONDELLA PIANA D.10 x 30 mm	WASHER D.10 x 30 mm	4	
7	X20.088.000	CAVALLOTTO POSTERIORE CARTER VENTOLA	BACK COVER BRACKET	2	
8	XD0.10.5588G	DADO M 10 6S PG	M10 6S BIG LEAD NUT 5588	4	
9	X04.720.000	VENTOLA D.450 X P/T/LP/TP45	FAN 450	1	
10	X05.654.200	RETE PROTEZIONE VENTILATORE	FAN NET PROTECTION	1	
11	XTE.010.080T	VITE M10x80	M10x80 BOLT	2	
12	XDOT.10.5587	DADO OTTONE M10	M10 BRASS NUT	2	
13	XRP.006.018	RONDELLA PIANA D. 6x18	WASHER D.6x18	4	
14	XTE.006.016T	VITE TE M6X16	SCREW TE M6X16	4	

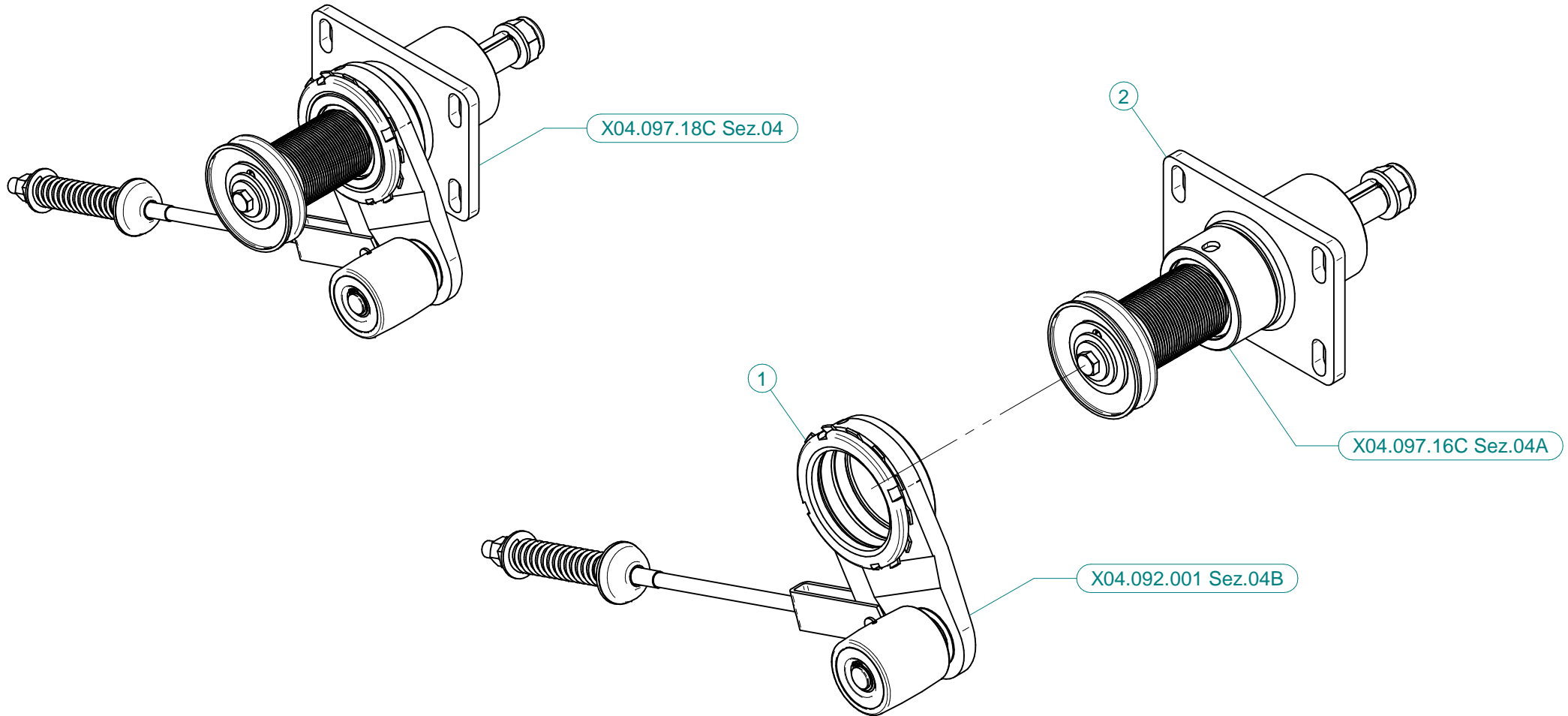

N°	Doc. Number	Titolo	Title	Q.tà
1	X04.092.001	TENDICINGHIA AUTOMATICO COMPLETO	AUTOMATIC BELT STRETCHER	1
2	X04.097.16C	SUPPORTO VENTOLA 42 - PUL D. 55 SENZA DISINNESTO	FAN SUPPORT 42 - PUL D. 55 NO DISENGANGEMENT	1

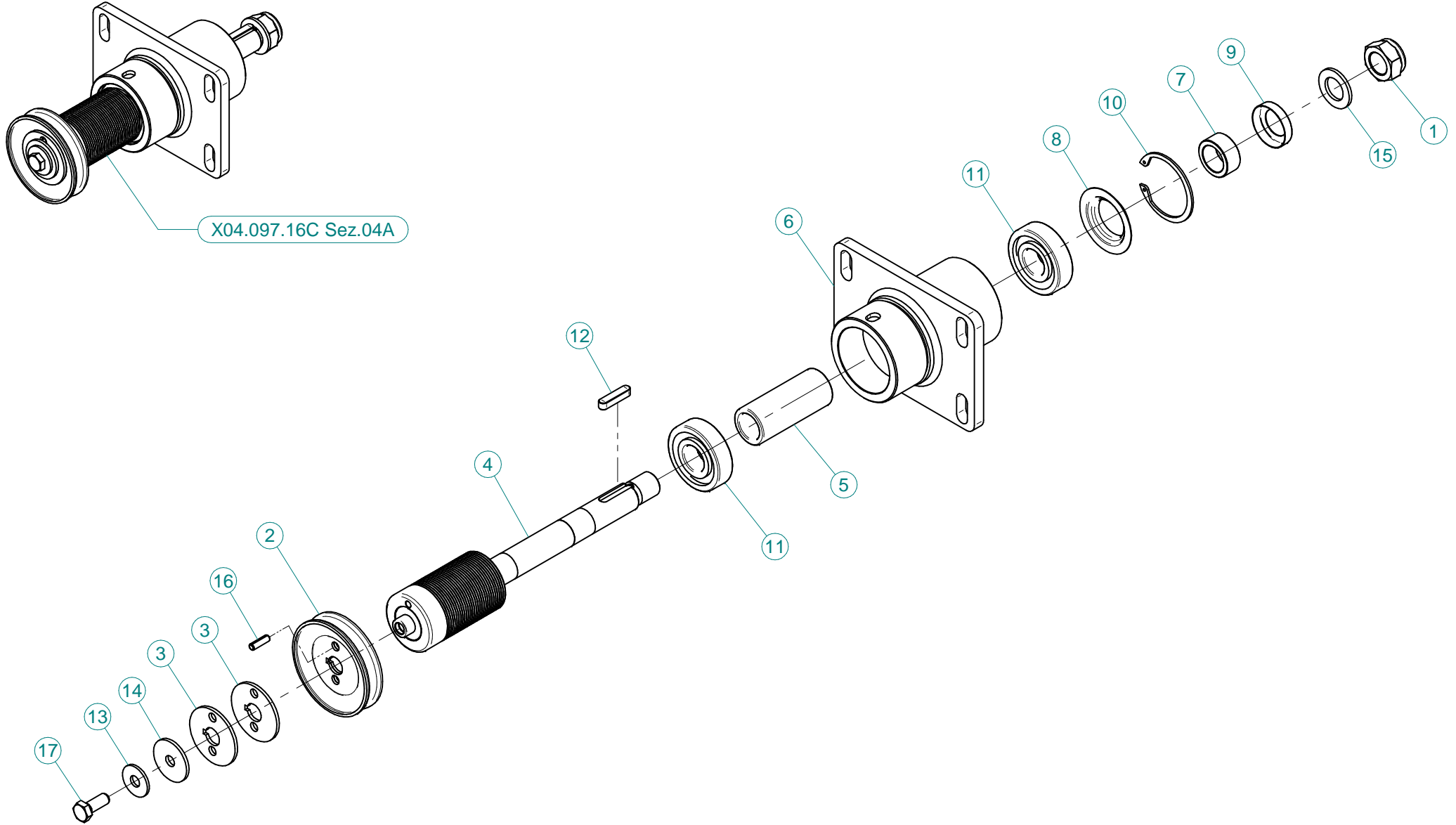



N°	Doc. Number	Titolo	Title	Q.tà
1	XDA.022.0BF	DADO ESAGONALE M22 AUTOBLOCCANTE	SELF-LOCKING NUT M22 x 1,5	1
2	X02.723.000	PULEGGIA COMANDO POMPA D.88 X 1 3V	PULLEY FOR PUMP D.88 X 1 3V	1
3	X02.723.001	RONDELLA SPECIALE mm3	SPECIAL WASHER mm3	2
4	X04.086.055	ALBERO VENTILATORE COMPLETO DI PULEGGIA Ø55mm	SHAFT WITH PULLEY -NO DISENGAGEMENT- Ø55mm	1
5	X04.087.000	DISTANZIALE ALBERO VENTILATORE	SHAFT SPACER	1
6	X04.097.000	SUPPORTO VENTILATORE INNESTO PLUS 42	FAN SUPPORT	1
7	X04.098.000	DISTANZIALE ALBERO VENTILATORE LATO VENTOLA	SPACER	1
8	X04.800.000	COPERCHIETTO PARAPOLVERE	COVER	1
9	X04.801.000	COPERCHIETTO PARAPOLVERE	COVER	1
10	XI0.062.000	ANELLO ELASTICO INTERNO D. 62	INTERNAL D. 62 CIRCLIP	1
11	XK6.305.2RS	CUSCINETTO	BEARING	2
12	XL.08.07.35	LINGUETTA 8x7x35	8x7x35 TANG	1
13	XRP.010.030	RONDELLA PIANA F. LARGA D.10X30 ZINC.	10X30mm D. LARGE THREAD FLAT	1
14	XRP.010.040	RONDELLA PIANA F. LARGA Ø10X40	WASHER Ø 10 X 40	1
15	XRP.022.000	RONDELLA PIANA D.22	WASHER D.22	1
16	XSE.006.020	SPINA ELASTICA ø6x20	SPRING PIN D.6x20	1
17	XTE.010.025FT	VITE TE UNI 5740-65	SCREW TE UNI 5740-65	1

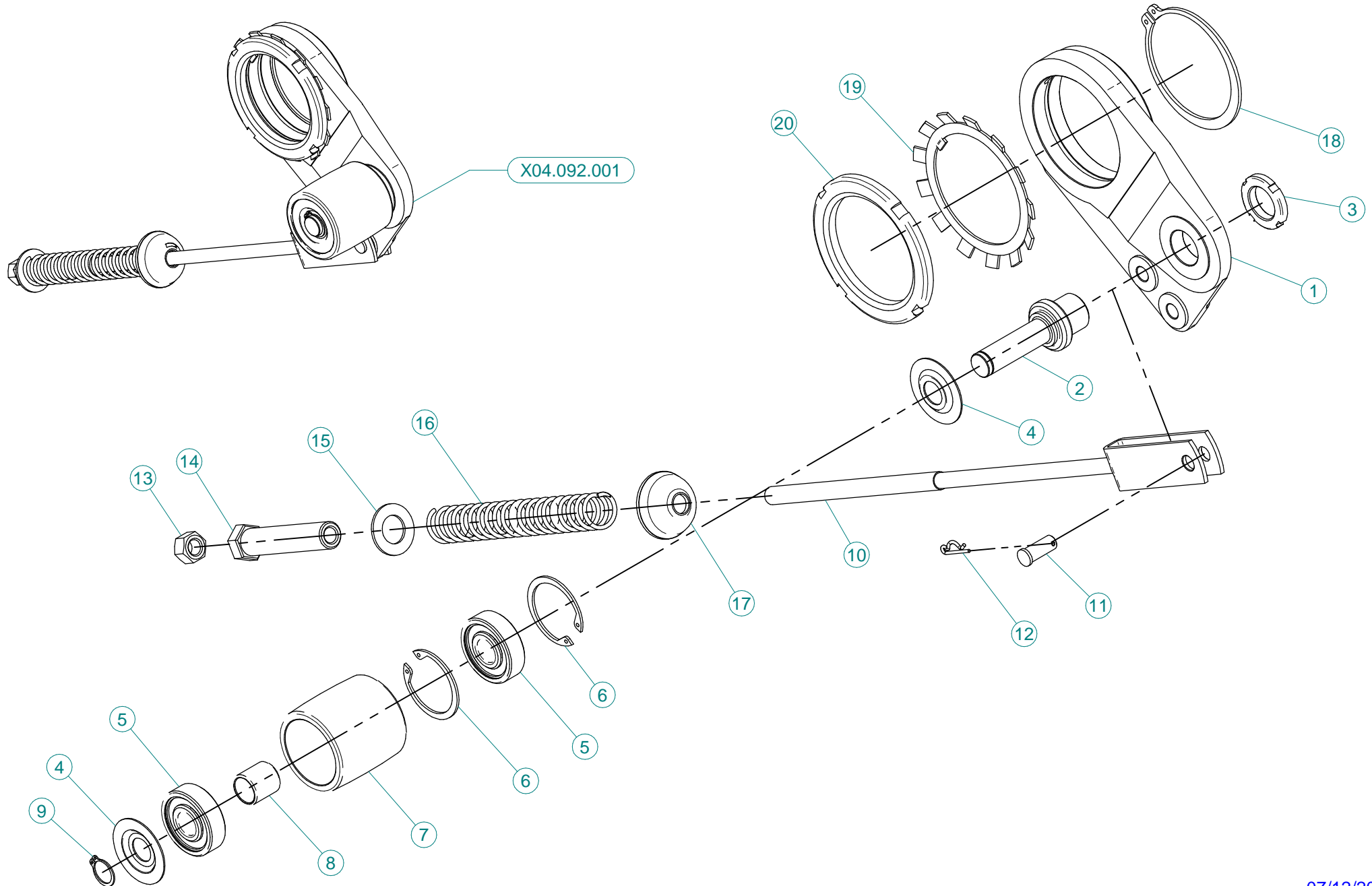

N°	Doc. Number	Titolo	Title	Q.tà	Note
1	X04.095.000	SUPPORTO PER TENDICINGHIA AUTOMATICO	BELT STRETCHER HOUSING	1	
2	X04.096.000	PERNO PER TENDICINGHIA AUTOMATICO	BELT STRETCHER PIN	1	
3	XKM.005.000	GHIERA KM5	NUT KM5	1	
4	X04.080.000	COPERCHIETTO PARAPOLVERE TENDICINGHIA AUTOMATICO	DUST COVER	2	
5	XK6.303.2RS	CUSCINETTO A SFERE	ROLLER BEARING	2	
6	XI0.047.000	ANELLO ELASTICO INTERNO D.47	INTERNAL D.47 CIRCLIP	2	
7	X04.089.000	RULLO TENDICINGHIA AUTOMATICO	ROLLER FOR BELT STRETCHER	1	
8	X04.090.000	DISTANZIALE PER TENDICINGHIA AUTOMATICO	SPACER FOR BELT STRETCHER	1	
9	XE0.017.000	ANELLO ELASTICO ESTERNO D.17	EXTERNAL D.17 CIRCLIP	1	
10	X05.653.000	FORCELLA TENSIONE TENDICINGHIA	BELT TRETCHER FORK	1	
11	X04.593.000	PERNO FORCELLA TENDICINGHIA	PIN	1	
12	X00.100.002	COPIGLIA	CLIP	1	
13	XDO.12.5588G	DADO M12 PG 5588	M12 6S BIG LEAD NUT 5588	1	
14	X04.583.000	VITE SPECIALE MOLLA TENDICINGHIA	SPECIAL SCREW	1	
15	XRP.019.000	RONDELLA PIANA D.19 6592	WASHER D.19	1	
16	X04.093.100	MOLLA TENDICINGHIA AUTOMATICO	SPRING	1	
17	X20.260.000	RONDELLA BOMBATA D.12 PER TENDICINGHIA	SPECIAL WASHER D.12	1	
18	XE0.080.000	ANELLO ELASTICO ESTERNO D.80	EXTERNAL D 80 CIRCLIP	1	
19	XMB.016.000	ROSETTA DI SICUREZZA MB 16	TOOTH LOCK WASHER MB 16	1	
20	X04.099.000	GHIERA DI REGISTRO M 80x2	NUT M 80x2	1	

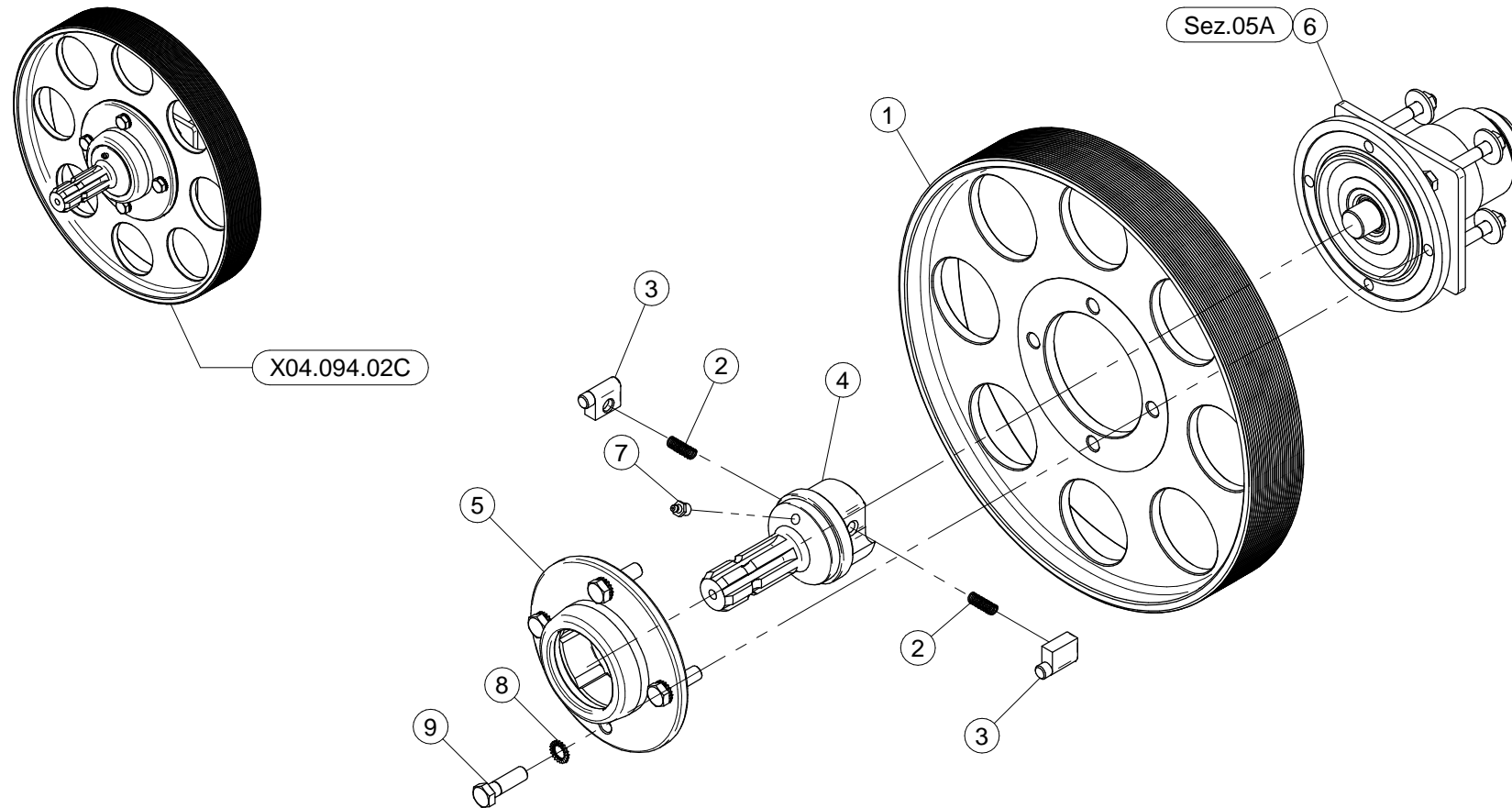

N°	Doc. Number	Titolo	Title	Q.tà
1	X00.400.J24	PULEGGIA INFERIORE D.400J24 (4091)	PULLEY 400 D.	1
2	X02.502.001	MOLLA A COMPRESSIONE	SPRING	2
3	X02.502.002	MARTELLETTO RUOTA LIBERA	PIN	2
4	X03.701.000	ROTORE RUOTA LIBERA	ROTOR	1
5	X04.066.000	CORPO ESTERNO RUOTA LIBERA	BODY	1
6	X04.094.01C	SUPPORTO INFERIORE P40 - P/T45 - LP/TP45	CLUTCH	1
7	XID.010.001	INGRASSATORE DIRITTO M10X1	GREASE NIPPLE	1
8	XRD.012.000	RONDELLA DENTELLATA D.12	TAB WASHER D.12	4
9	XTE.012.040F	VITE TE UNI 5738-65 M12X40-8.8	SCREW TE UNI 5738-65 M12X40-8.8	4

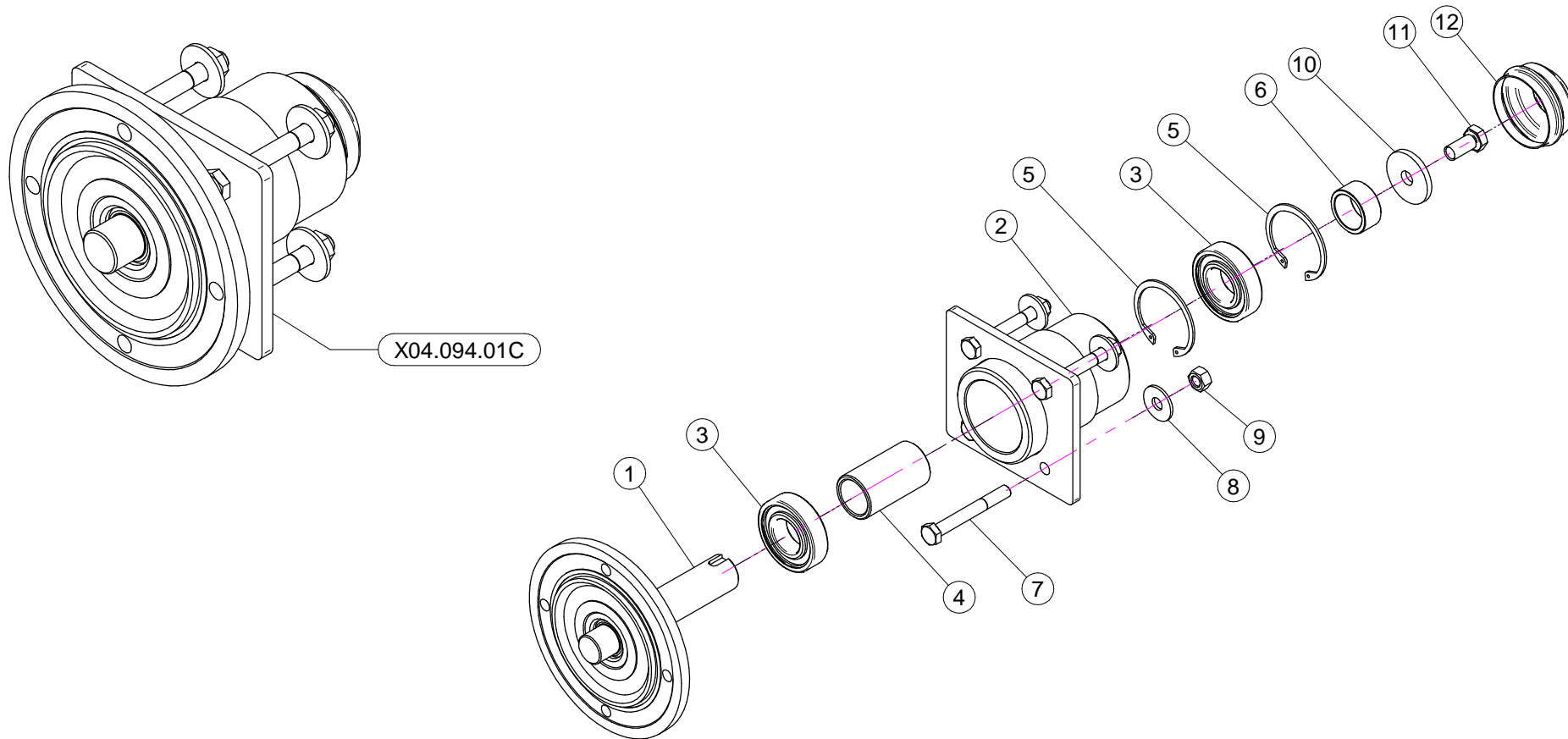

N°	Doc. Number	Titolo	Title	Q.tà	Note
1	X04.085.000	ALBERO INFERIORE	SHAFT	1	
2	X04.094.000	SUPPORTO INFERIORE	CLUTCH	1	
3	XK6.206.2RS	CUSCINETTO	BEARING	2	
4	X04.060.000	DISTANZIALE PER ALBERO INFERIORE	SPACER	1	
5	XI0.062.000	ANELLO ELASTICO INTERNO D. 62	INTERNAL D. 62 CIRCLIP	2	
6	X04.590.000	DISTANZIALE PER ALBERO INFERIORE	SPACER	1	
7	XTE.010.080	VITE TE M10X80 5737 ZINC.	BOLT TE M10X80 5737	4	
8	XRP.010.030	RONDELLA PIANA F.LARGA D.10X30 ZINC.	10X30mm D. LARGE THREAD FLAT	4	
9	XD0.10.5587G	DADO M10 6S PG 5587 ZINC.	M10 6S BIG LEAD NUT 5587	4	
10	X20.810.000	RONDELLA SPECIALE PER SUPPORTO INFERIORE	SPECIAL WASHER FOR LOWER SUPPORT	1	
11	XTE.012.025FT	VITE TE UNI 5740-65 M12X25-8.8	SCREW TE UNI 5740-65 M12X25-8.8	1	
12	X04.062.001	COPERCHIETTO DI CHIUSURA	COVER	1	

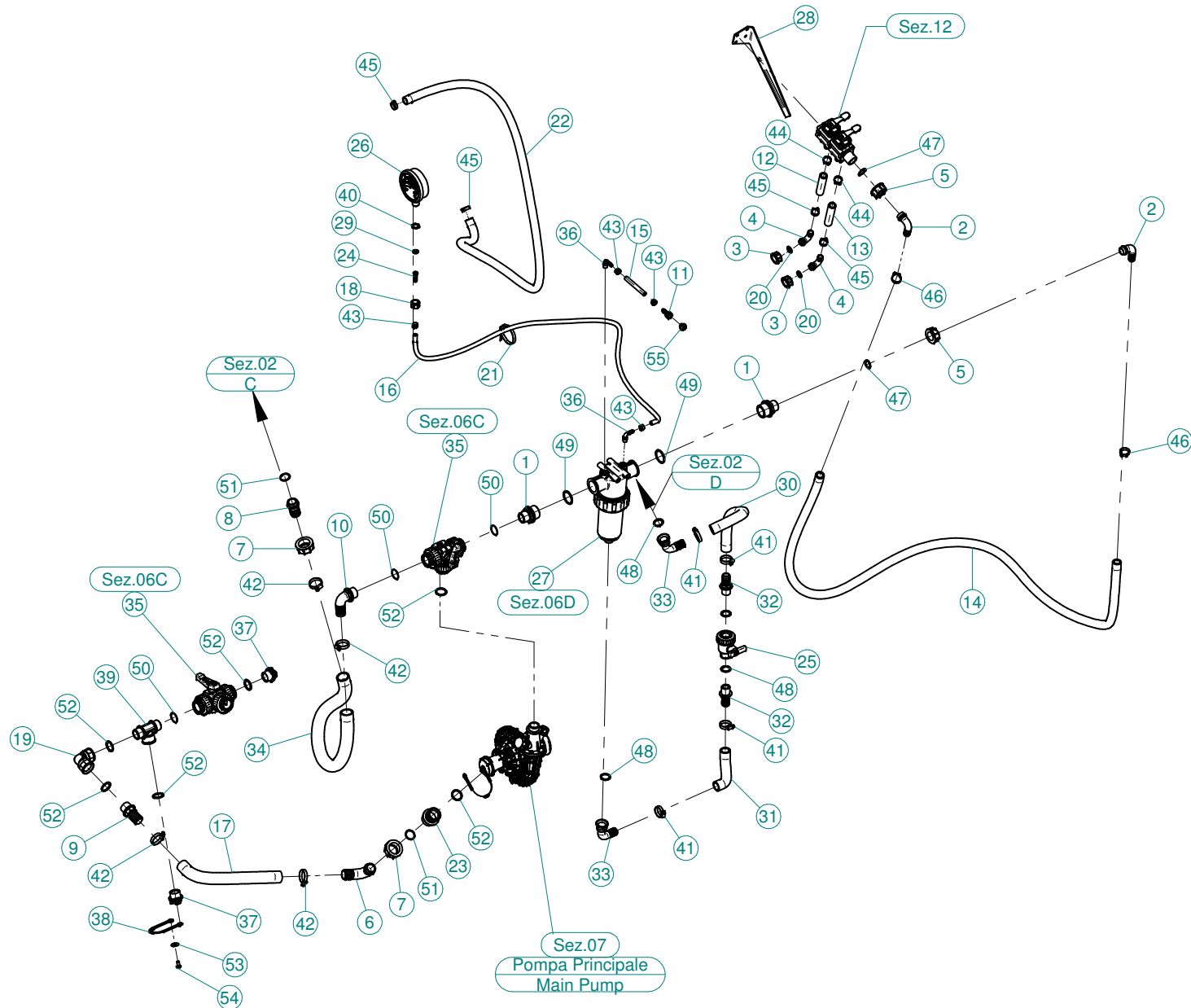

N°	Doc. Number	Titolo	Title	Q.tà	N°	Doc. Number	Titolo	Title	Q.tà
1	X00.045.012	RIDUZIONE 1" 1/4 M - 1" M	1" 1/4 M - 1" M REDUCER NIPPLE	2	34	X20.852.080	TUBO CON RAMINO ø30 L 800MM	HOSE ø30 L 800MM	1
2	X00.055.038	RACCORDO CURVO A P.G. Ø19	CURVED UNION WITH R.H. Ø19	2	35	X21.058.100	VALVOLA 3 VIE COMPLETA	THREE WAYS VALVE COMPLETE	2
3	X00.055.045	GIRELLO 3/4" GAS ALTO	3/4" GAS FLY NUT	2	36	X21.084.000	RACCORDO 90° WES 8 / R1/4	HOSETAIL 90° WES 8 / R1/4	2
4	X00.055.046	RACCORDO CURVO P.G. Ø16	CURVED UNION WITH R.H. Ø17	2	37	X21.182.000	TAPPO 1" M	PACKING 1" M	2
5	X00.055.24.2	GIRELLO 1" GAS	1" FLY NUT	2	38	X21.183.000	STRISCIA FERMATAPPI	CAP FASTENER BEND	1
6	X00.058.004	RACCORDO CURVO P.G. Ø30	Ø30 HOSETAIL	1	39	X24.065.000	RACCORDO A T 1"M-1"M-1"F	T 1"M-1"M-1"F	1
7	X00.058.006	GIRELLO 1" 1/4 GAS	1" 1/4 FLY NUT	2	40	X24.072.000	GHIERA IN OTTONE 1/2"	BRASS FLY NUT 1/2"	1
8	X00.058.028	RACCORDO DIRITTO PG Ø30	STRAIGHT HOSE R.H Ø30	1	41	XF0.023.035I	FASCETTA A VITE 23/35 W4 INOX	STAINLESS STEEL CLIP	4
9	X00.422.000	RACCORDO DIRITTO PG 30 FIL.1" GAS	MALE CONNECTOR RH 30 1" GAS	1	42	XF0.025.040I	FASCETTA A VITE 25/40 W4 INOX	STAINLESS STEEL CLIP	4
10	X00.465.000	RACCORDO CURVO A P.G. D.30 1" GAS	HOSETAIL D.30 1" GAS	1	43	XFC.013.5.015	FASCETTA COBRA SL030710	KOBRA CLAMP SL030710	4
11	X02.007.011	RACCORDO DIRITTO PG Ø 11	STRAIGHT UNION R.H. Ø 11	1	44	XFC.021.5.023	FASCETTA COBRA SL030750 21,08 W4	CLAMP 21,5-23	2
12	X02.211.110	TUBO ø16 L1100MM	HOSE ø16 L1100MM	1	45	XFC.023.5.025	FASCETTA COBRA SLO30761	KOBRA CLAMP SLO30761	4
13	X02.211.110	TUBO ø16 L 1100MM	HOSE ø16 L 1100MM	1	46	XFC.027.5.029	FASCETTA COBRA 27,08 - W8	KOBRA CLAMP 27,08 - W8	2
14	X02.212.400	TUBO ø19 L 4000MM	HOSE ø19 L4000 MM	1	47	XOR.000.132	OR Ø23,81 x 2,62	23,81 x 2,62 O-RING GASKET	2
15	X02.217.020	TUBO ø8 L 200MM	HOSE ø8 L 200MM	1	48	XOR.000.134	OR Ø25,8x3,53	O-RING Ø25,8x3,53	4
16	X02.217.135	TUBO ø8X13 L 1350MM	HOSE ø8X13 L 1350MM	1	49	XOR.000.144	OR Ø39,69x3,53	O-RING Ø39,69x3,53	2
17	X02.238.036	TUBO SPIRALATO ø30 L 360MM	SPIRALED HOSE ø30 L 360MM	1	50	XOR.002.125	OR Ø 31,47 x 1,78	31,47 x 1,78 O-RING GASKET	3
18	X02.287.000	GIRELLO 1/2"	FLY NUT 1/2"	1	51	XOR.003.112	OR Ø28,24x2,62	O-RING D.28,24x2,62	2
19	X02.291.000	RACCORDO CURVO 1" FEMMINA	FEMALE HOSETAIL THREAD 1"	1	52	XOR.004.118	OR Ø 29,75 x 3,53	29,75 x 3,53 O-RING GASKET	6
20	X02.349.000	GUARNIZIONE PIANA D.17X23X3	17X23X3 FLAT GASKET (G4000B)	2	53	XRP.008.024	RONDELLA PIANA F.LARGA D.8X24 ZINC.	WASHER D.8X24	1
21	X02.355.000	FASCETTA D'ASSEMBLAGGIO 292 mm	NYLON ASSEMBLY CLAMP	1	54	XTE.008.016T	VITE TE UNI 5739-65 M8x16-8.8	SCREW TE UNI 5739-65 M8x16-8.8	1
22	X02.372.180	TUBO SPIRALATO ø19 L=1800 mm	SPIRALED HOSE ø19 L=1800 mm	1	55	XTM.014.000	TAPPO MASCHIO 1/4"	MALE PLUG 1/4"	1
23	X02.374.000	RIDUZIONE M/F 1"F / 1"1/4M	M. / F. 1"F / 1"1/4M REDUCTION	1					
24	X02.379.020	RACCORDO P.G. 10 SPIANATO	STRAIGHT UNION R.H. 10	1					
25	X02.395.000	RUBINETTO 3/4" GAS F.F. SFERA	VALVE 3/4" GAS F.F. BALL	1					
26	X02.445.000	MANOMETRO D.100 INOX 0-6 BAR	PRESSURE GAUGE Ø100 INOX 0-6 BAR	1					
27	X02.450.110	FILTRO IN LINEA F. 1" 1/4	LINE FILTER 1" 1/4 FEMALE	1					
28	X20.112.000	SUPPORTO A BAIONETTA	SUPPORT CONTROL ASSY	1					
29	X20.769.000	GUARNIZIONE Ø 19,2/11,5 X 2,5	GASKET Ø 19,2/11,5 X 2,5	1					
30	X20.770.020	TUBO SPIRALATO ø25 L 200MM	SPIRALED HOSE ø25 L 200MM	1					
31	X20.770.030	TUBO SPIRALATO ø25 L 300MM	SPIRALED HOSE ø25 L 300MM	1					
32	X20.793.000	RACCORDO DIRITTO P.G. D.25 3/4" GAS M.	HOSETAIL R.H. D.25 3/4" GAS M.	2					
33	X20.794.000	RACCORDO CURVO 90° P.G. 25 3/4" GAS F	PIPE 90° R.H. 25 3/4" GAS F	2					

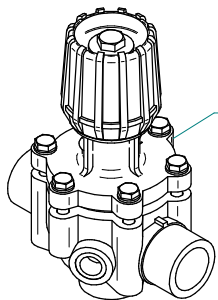

X02.447.300

NewPlus 42-45-50-55

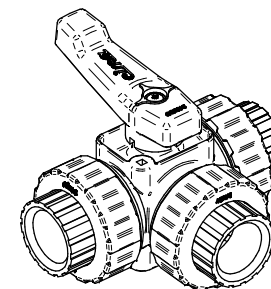
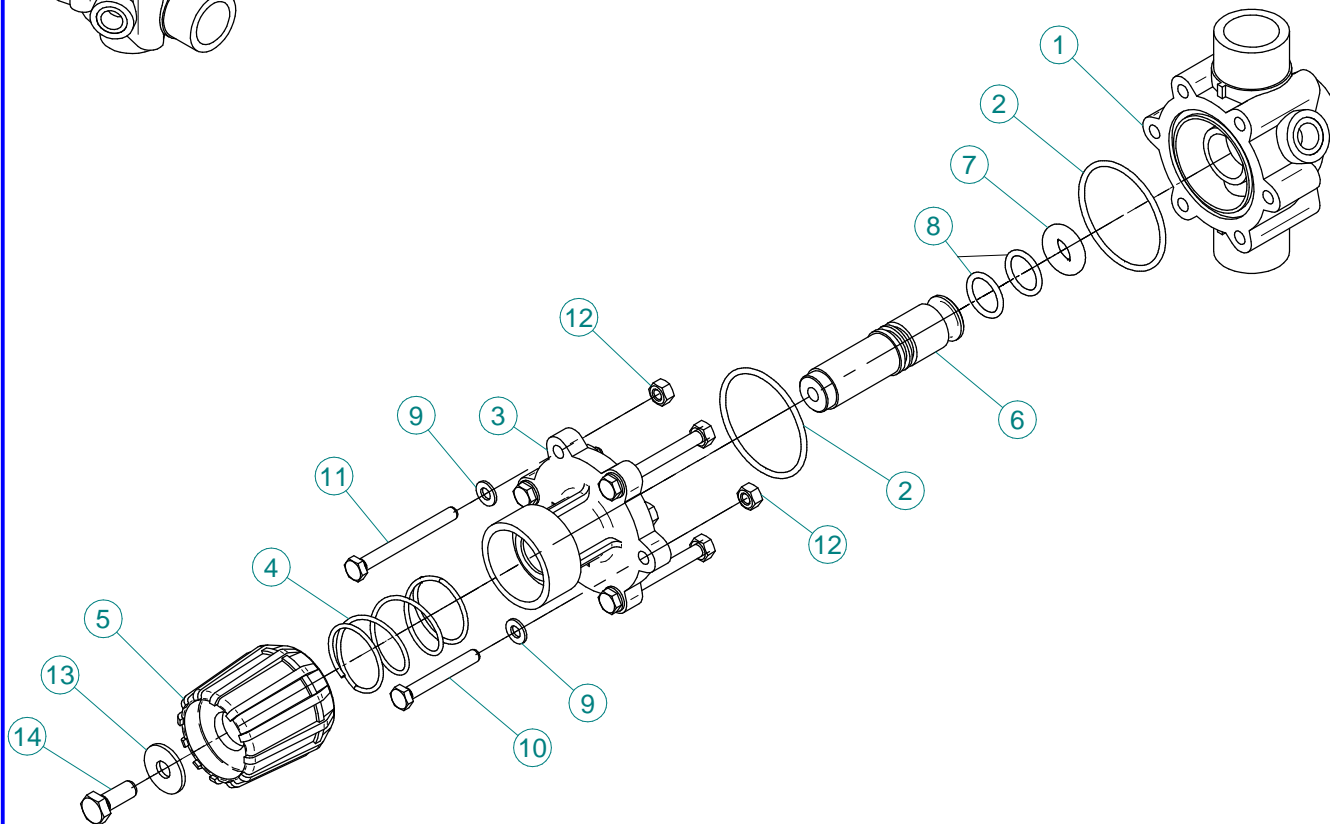

X21.058.100

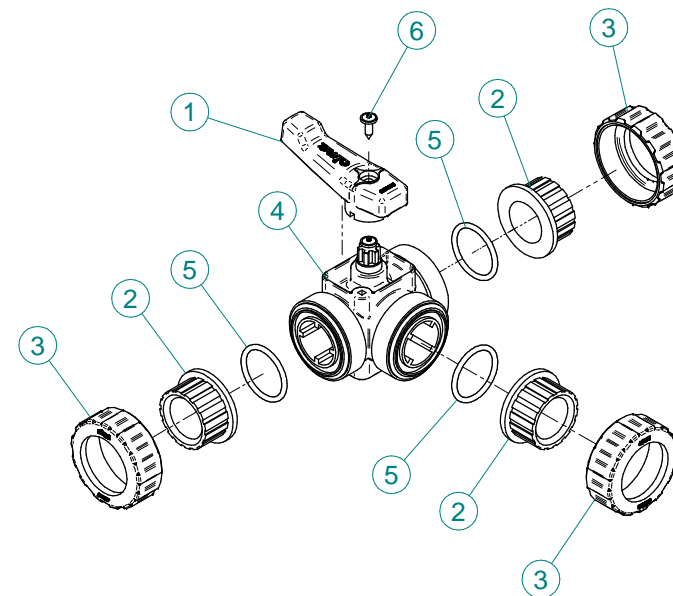



## X02.447.300

### NEW PLUS 42-45-50-55

N°	Doc. Number	Titolo	Title	Q.tà
1	X02.447.001	CORPO VALVOLA DI REGOLAZIONE	BODY FOR REGULATION VALVE	1
2	XOR.003.193	OR Ø48,89x2,62	O-RING GASKET 48,89x2,62	2
3	X02.447.012	FLANGIA SUPERIORE SERRANDA	UPPER FLANGE	1
4	X02.447.011	MOLLA RECUPERO GIOCO	SPRING	1
5	X02.447.010	MANOPOLA VALVOLA	REGULATION VALVE KNOB	1
6	X02.447.013	PERNO IN NYLON PER VALVOLA	VALVE PIN	1
7	X02.447.005	OR SPECIALE PER SERRANDA 2447	SPECIAL O-RING FOR GATE 2447	1
8	XOR.003.068	OR Ø17,12x2,62	O-RING GASKET 17,12x2,62	2
9	XRP.006.001	RONDELLA PIANA D.6 INOX	WASHER D.6	6
10	XTE.006.045I	VITE TE UNI 5737-65 M6x45 INOX	INOX SCREW TE UNI 5737-65 M6x45	2
11	XTE.006.060I	VITE TE UNI 5737-65 M6x60 INOX	INOX SCREW TE UNI 5737-65 M6x60	4
12	XDO.06.5588GI	DADO M6 6S PG INOX	INOX M6 6S BIG LEAD NUT 5588	6
13	XRP.008.024I	RONDELLA PIANA LARGA Ø8X24 INOX	INOX WASHER Ø8X24	1
14	XTE.008.025I	VITE TE UNI 5737-65 M8X25 INOX	INOX SCREW TE UNI 5737-65 M8X25	1

## X21.058.100

N°	Doc. Number	Titolo	Title	Q.tà
1	X21.058.003	MANIGLIA VALVOLA 3 VIE	VALVE HANDLE	1
2	X21.058.006	MANICOTTO VALVOLA 3 VIE	VALVE END CONNECTOR	4
3	X21.058.007	GHIERA VALVOLA 3 VIE	VALVE UNION NUT	3
4	X21.058.110	CORPO VALVOLA 3 VIE COMPLETO	BODY OF THREE WAYS VALVE	1
5	XOR.004.137	OR Ø34.52x3.53	O-RING Ø34.52x3.53	3
6	XTA.05.5.016	VITE AUTOFILETTANTE M5,5 x 16	SELFTHREATED SCREW M5,5 x 16	1

CODICE-CODE  
 X02.450.110

100mm

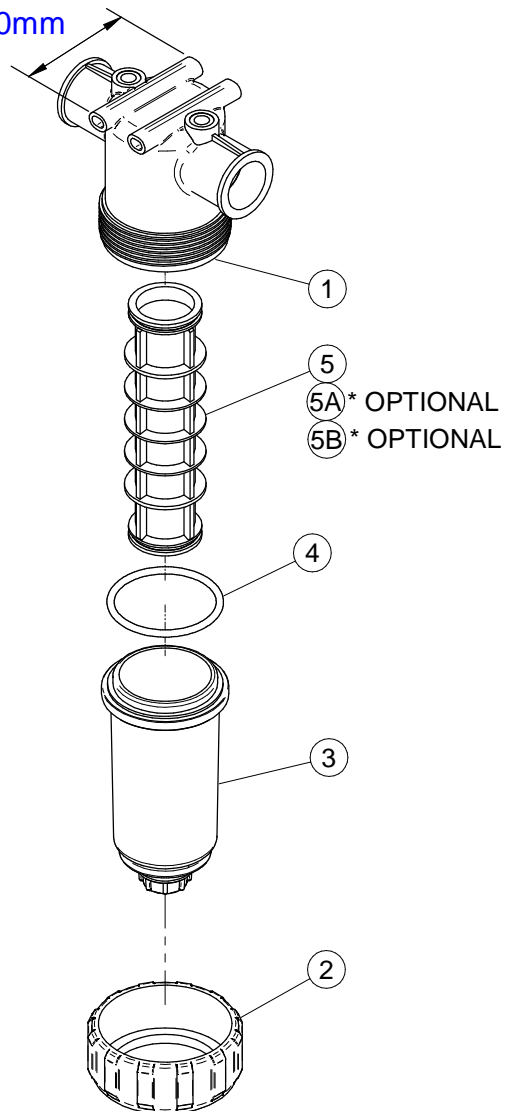

**X02.450.110**

N°	Doc. Number	Titolo	Title	Q.tà
1	X02.450.101	CORPO FILTRO IN LINEA F. 1 1/4"	LINE FILTER BODY	1
2	X02.450.003	GHIERA FILTRO IN LINEA	RING NUT FILTER IN LINE	1
3	X02.450.011	COPERCHIO FILTRO CON SCARICO D.3/4"	LID FILTER WITH UNLOADING	1
4	XOR.000.178	OR D.74,63x5,33	O-RING D.74,63x5,33	1
5	X02.450.104C	CARTUCCIA FILTRO CON OR 32 MESH (BIANCO)	CARTRIDGE WITH O-RING 32 MESH (WHITE)	1

\* OPTIONAL

5A	X02.450.004C	CARTUCCIA FILTRO CON OR 50 MESH (BLU)	CARTRIDGE WITH O-RING 50 MESH (BLUE)	1
5B	X02.450.204C	CARTUCCIA FILTRO CON OR 80 MESH (GRIGIO)	CARTRIDGE WITH O-RING 80 MESH (GREY)	1

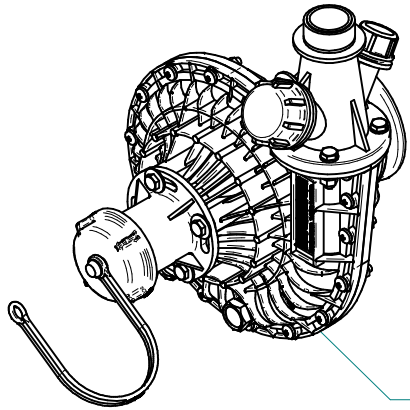

X02.157.068 NORMAL

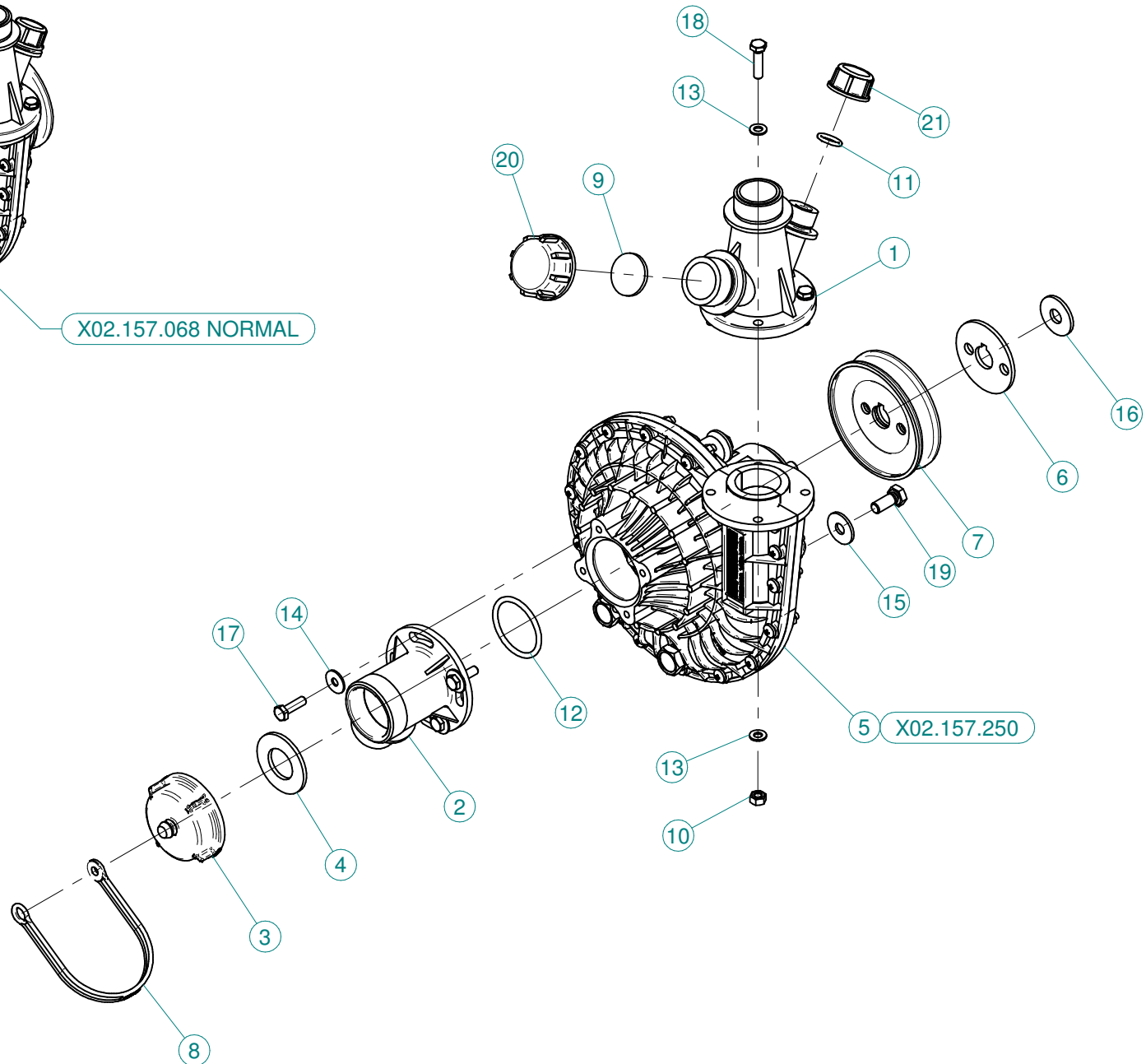

N°	Doc. Number	Titolo	Title	Q.tà
1	X02.113.001	RACCORDO DI MANDATA	DELIVERY FITTING	1
2	X02.116.000	RACCORDO DI ASPIRAZIONE	SUCTION FITTING	1
3	X02.120.000	TAPPO A FILETTO RAPIDO M47 x 5	RAPID THREAD CAP	1
4	X02.130.000	GUARNIZIONE IN GOMMA DIAM. 24X46X3	24X46X3 RUBBER GASKET	1
5	X02.157.250	POMPA COMPLETA	PUMP	1
6	X02.723.001	RONDELLA SPECIALE mm3	SPECIAL WASHER mm3	1
7	X02.723.002	PULEGGIA COMANDO POMPA D.82,5 X 1 3V	PULLEY FOR PUMP D.82,5 X 1 3V	1
8	X21.183.000	STRISCIA FERMATAPPI	CAP FASTENER BEND	1
9	X24.100.000	GUARNIZIONE PIANA D.30x3 PER TAPPO D. 1"	GASKET D.30 x 3	1
10	XDOT.06.5587	DADO OTTONE M6	M6 BRASS NUT 5587	4
11	XOR.000.117	OR D.13,1X2,62	13.1X2.62 O-RING GASKET	1
12	XOR.000.144	OR Ø39,69x3,53	O-RING Ø39,69x3,53	1
13	XRP.006.000	RONDELLA PIANA D.6 6592 ZINC.	6mm D. FLAT WASHER	8
14	XRP.006.018	RONDELLA PIANA F.LARGA D.6X18 ZINC.	WASHER Ø 6x18	4
15	XRP.008.024	RONDELLA PIANA F.LARGA D.8X24 ZINC.	WASHER D.8X24	3
16	XRP.010.030	RONDELLA PIANA F.LARGA D.10X30 ZINC.	10X30mm D. LARGE THREAD FLAT	1
17	XTE.006.020T	VITE TE M6X20 5739 ZINC.	BOLT TE M6X20 5739	4
18	XTE.006.025T	VITE TE UNI 5739-65 M6X25-8.8	SCREW TE UNI 5739-65 M6X25-8.8	4
19	XTE.008.020T	VITE TE UNI 5739-65 M8x20-8.8	SCREW TE UNI 5739-65 M8x20-8.8	3
20	XTF.001.000	TAPPO 1"	PACKING	1
21	XTF.012.000	TAPPO F. DA 1/2" GAS	BLANK CAP 1/2"	1

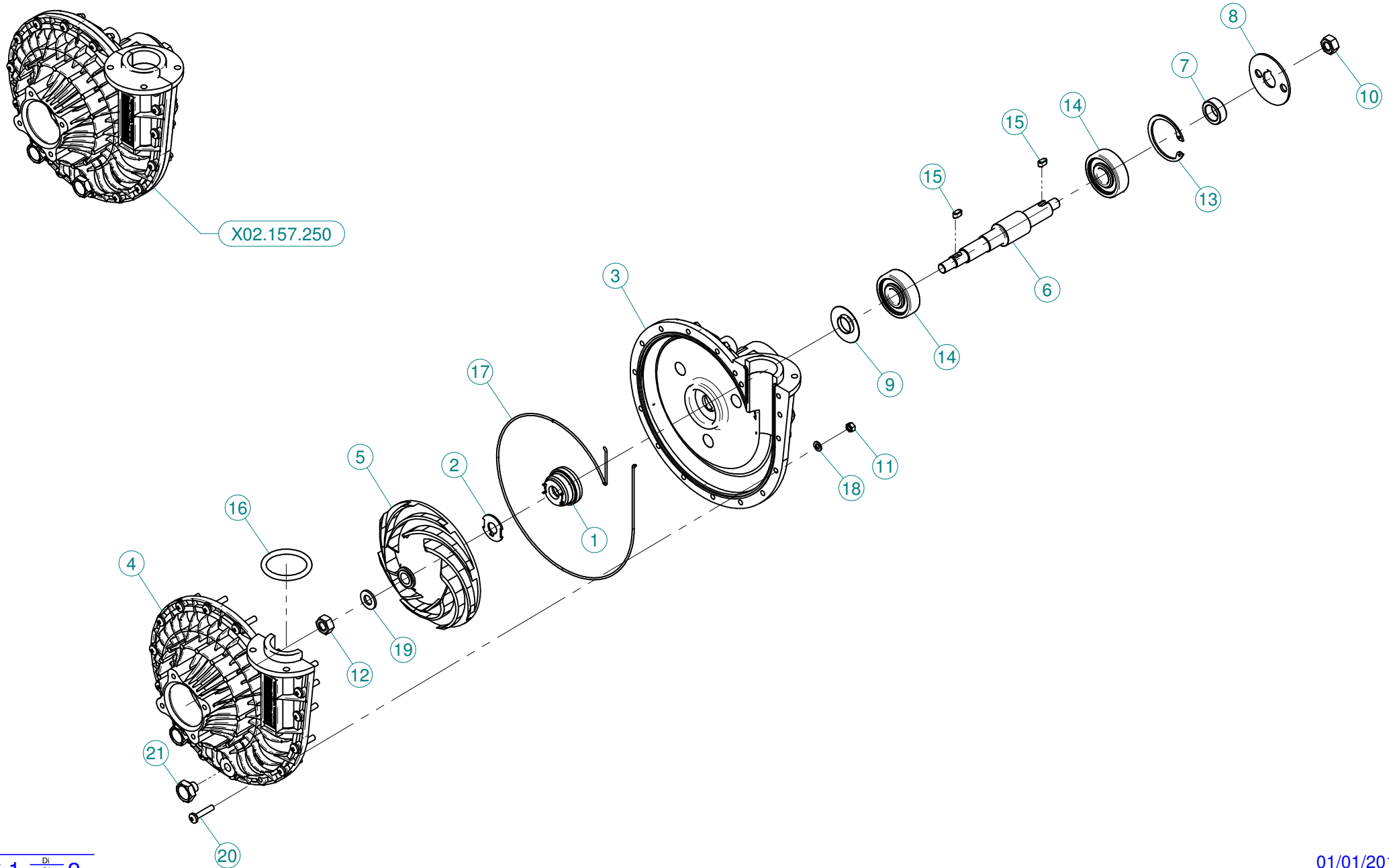

X02.157.250

N°	Doc. Number	Titolo	Title	Q.tà
1	X00.085.024CS	TENUTA MECCANICA	MECHANICAL SEAL	1
2	X02.114.000	RONDELLA SPECIALE INOX	INOX SPECIAL WASHER	1
3	X02.151.011	CORPO POMPA CD 32 LUNGO	PUMP CASING MODEL 2013	1
4	X02.152.011	COPERCHIO POMPA CD 32	HOUSING	1
5	X02.153.000	GIRANTE POMPA CD 32	CD 32 PUMP IMPELLER	1
6	X02.155.010	ALBERO POMPA CD 32 INOX LUNGO	CD32 PUMP SHAFT	1
7	X02.722.000	DISTANZIALE POMPA	BUSH	1
8	X02.723.005	RONDELLA SPECIALE mm2	SPECIAL WASHER mm2	1
9	X20.406.000	COPERCHIETTO SPECIALE POMPA CD 32	SPECIAL COVER FOR PUMP	1
10	XD0.10.5588G	DADO M10 NORMALE 5588G	NUT M10 NORMAL 5588G	1
11	XDOT.05.5587	DADO OTTONE M5 (5587)	M5 BRASS NUT (5587)	17
12	XDOT.10.5587	DADO OTTONE M10 ALTO 5587	M10 HIGH BRASS NUT 5587	1
13	XI0.047.000	ANELLO ELASTICO INTERNO D.47	INTERNAL D.47 CIRCLIP	1
14	XK6.303.2RS	CUSCINETTO A SFERE	ROLLER BEARING	2
15	XL.05.05.10	LINGUETTA 5X5X10	5X5X10 TANG	2
16	XOR.006.162	OR Ø40,65 x 5,34	O-RING GASKET 40,65 x 5,34	1
17	XOR.C02.070	CORDA OR Ø2 L=700	OR CORD Ø2 L=700	1
18	XRP.005.000	RONDELLA PIANA Ø5	WASHER Ø5	17
19	XRP.010.00I	RONDELLA PIANA Ø10 INOX	WASHER Ø10 INOX	1
20	XTC.05.25.85	VITE TESTA A GROCE 48 M5X25	CROSS SLOTTED SCREW M5X25	17
21	XTM.010.015	TAPPO M10X1,5	M10X1,5 CAP	2

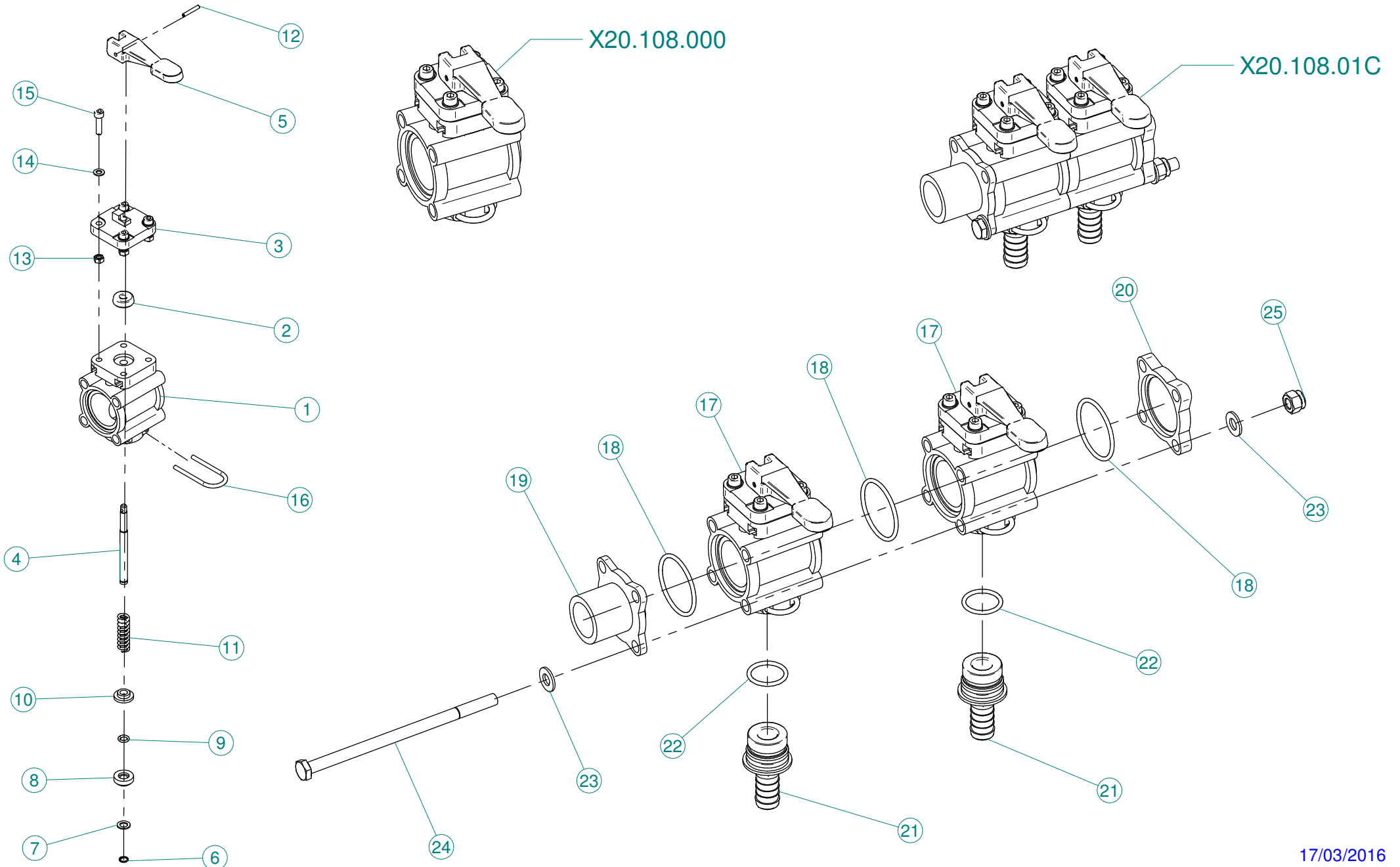

**X20.108.000**

N°	Doc. Number	Titolo	Title	Qtà
1	X02.390.007	CORPO VALVOLA	VALVE BODY	1
2	X02.390.008	GUARNIZIONE D.6x17x6 VITON	GASKET	1
3	X02.390.021	FLANGIA VALVOLA DEVIATORE MANUALE	FLANGE	1
4	X02.390.020	PERNO VALVOLA MANUALE INOX	PIN	1
5	X20.108.002	LEVA GRUPPO COMANDO MANUALE	LEVER FOR MANUAL SWITCH	1
6	X02.390.013	ANELLO ARRESTO	STOP RING	1
7	X02.390.014	RONDELLA PIANA 7,2 x 12 INOX	WASHER	1
8	X02.390.015	PIATTELLO INFERIORE VALVOLA	WASHER	1
9	X02.390.016	OR 6,7 x 1,78	O RING	1
10	X02.390.009	PIATTELLO SUPERIORE VALVOLE	CAP	1
11	X02.390.011	MOLLA DI RITEGNO	SPRING	1
12	XSE.003.020	SPINA ELASTICA D.3 L=20	SPRING PIN D.3 L=20	1
13	XDO.05.5588G	DADO M5	NUT M5	4
14	XRP.005.000	RONDELLA PIANA D.5 (6692)	WASHER D.5	4
15	XTCE.005.020	VITE BRUGOLA TCE M5 x 20	CAP SCREW M5 x 20	4
16	X02.390.005	FORCHETTA PER RUB. MAN. SEMP. PR	FORK	1

**X20.108.01C**

N°	Doc. Number	Titolo	Title	Qtà
17	X20.108.000	VALVOLA SEMPLICE GRUPPO COM. MAN.	MANUALLY OPERATED VALVE	2
18	XOR.003.156	OR D.39x2.62	O-RING GASKET 39x2.62	3
19	X02.390.018	RACCORDO FLANGIATO 1" GAS	CONNECTOR	1
20	X02.390.017	FLANGIA VALVOLE	VALVE FLANGE	1
21	X02.406.000	PORTAGOMMA D.16 ATT.RAP. PER ELETT.	HOSETAIL D.16	2
22	XOR.000.130	OR D.22.22 x 2.62	22.22 x 2.62 O-RING GASKET	2
23	XRP.008.000	RONDELLA PIANA D.8	WASHER D.8	8
24	XTE.008.150	VITE TE M8x150	SCREW TE M8 x 150	4
25	XDA.008.0AG	DADO AUTOBLOCCANTE M8	SELF LOCKING NUT M8	4



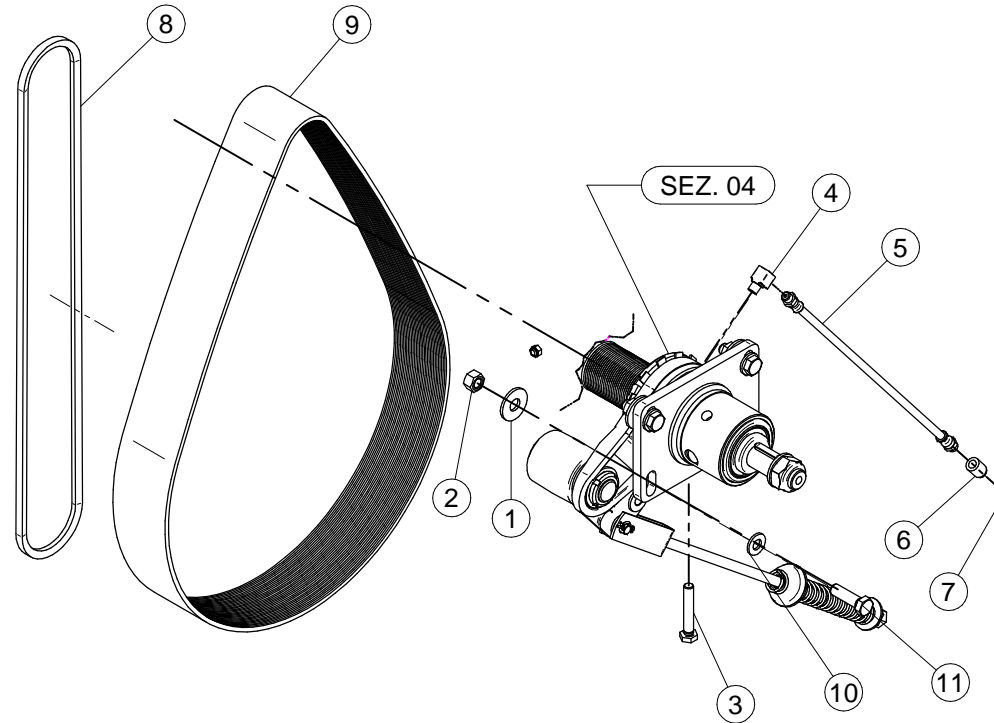

N°	Doc. Number	Titolo	Title	Q.tà	Note
1	XRP.012.036	RONDELLA PIANA D12 X 36	WASHER D12 X 36	4	
2	XD0.12.5587G	DADO M12 PG UNI 5587	M12 NUT	4	
3	XTE.010.060T	VITE TE UNI 5739-65 M10x60-8.8	SCREW TE UNI 5739-65 M10x60-8.8	1	
4	X02.736.000	RACCORDO INGRASSAGGIO 90 G. M10 X1	90 G. M10 X1 FITTING	1	
5	X02.738.040	PROLUNGA FLESSIBILE M10 x 1 L= 400	GREASER EXTENSION M10 x 1 L= 400	1	
6	X02.737.000	BOCCOLA PER INGRASSATORE	ACCESSORI	1	
7	XID.010.001	INGRASSATORE DIRITTO M 10X1 ZINC.	STRAIGHT GREASE NIPPLE	1	
8	XC0.530.03V	CINGHIA TRAPEZOIDALE	V - BELT	1	
9	XC0.610.J24	CINGHIA POLY-V	POLY-V BELT	1	
10	XRP.012.000	RONDELLA PIANA Ø12	WASHER Ø12	4	
11	XTE.012.040T	VITE TE UNI 5739-65 M12X40-8.8	SCREW TE UNI 5739-65 M12X40-8.8	4	



New Plus 42 - 45 - 50 - 55

## Adesivi per la sicurezza



- ARRESTARE IL MOTORE E TOGLIERE LA CHIAVE DAL QUADRO COMANDI DELLA TRATTRICE PRIMA DI OGNI OPERAZIONE DI MANUTENZIONE O RIPARAZIONE.
- CONSULTARE IL MANUALE USO E MANUTENZIONE PRIMA DI UTILIZZARE O INTERVENIRE SULLA MACCHINA

95001



- CONSULTARE IL MANUALE USO E MANUTENZIONE PRIMA DI UTILIZZARE LA MACCHINA
- PERICOLO DI CONTAMINAZIONE PER CONTATTO OD INALAZIONE DI PRODOTTI VELENOSI.
- È VIETATO INTRODURSI NEL SERBATOIO!

95098



- PERICOLO DI SPRUZZI. RIMANERE A DISTANZA DI SICUREZZA.
- PERICOLO ORGANI ROTANTI. PRIMA DI RIMUOVERE LE PROTEZIONI FERMARE LA TRATTRICE, TOGLIERE LA CHIAVE DAL QUADRO COMANDI ED ASSICURARSI CHE GLI ORGANI SI SIANO FERMATI.

95099



- PERICOLO: MONTARE LE RUOTE DOPO AVER AGGANCIATO LA MACCHINA AL SOLLEVATORE E SMONTARLE PRIMA DI SGANCIARE LA MACCHINA DAL SOLLEVATORE (per versioni dove previsto)

95012



- PRIMA DI UTILIZZARE IL DISINNESTO FERMARE LA TRATTRICE TOGLIERE LA CHIAVE DAL QUADRO COMANDI ED ASSICURARSI CHE IL VENTILATORE SIA FERMO.

95015



- Velocità MASSIMA DI ESERCIZIO DELLA P.d.P.: 540 GIRI AL MINUTO.

95010



- PERICOLO. UTILIZZARE I GUANTI PER SVUOTARE IL SERBATOIO.

95009

## Adesivi per l'uso e la manutenzione



- CONTROLLARE IL LIVELLO OLIO OGNI 8 ORE: CUSCINETTI ALBERO VENTILATORE.

95079



- RUBINETTO DEL SERBATOIO LAVAMANI Impreso vicino al rubinetto.

95057

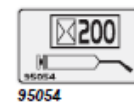

- INGRASSARE OGNI 200 ORE: SUPPORTO TENDICINGHIA VENTILATORE E RUOTA LIBERA.

95054

New Plus 42 - 45 - 50 - 55



95105

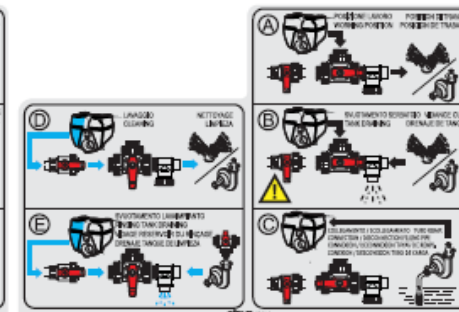

95104

- INDICAZIONI SUL FUNZIONAMENTO DEL RUBINETTO A 3 VIE (P2) (e P15 per versioni dove previsto)



95059

- PUNTO DI AGGANCIO PER IL SOLLEVAMENTO DELLA MACCHINA



95102

- INDICAZIONE DEL PRODOTTO IMPIEGATO PER IL TRATTAMENTO

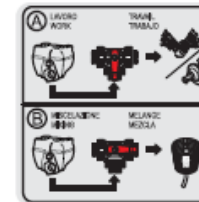

95058

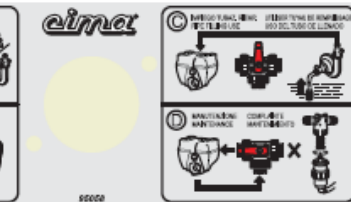

- INDICAZIONI SUL FUNZIONAMENTO DEL RUBINETTO A 3 VIE (P6)



95056

- INDICAZIONE DELLA PRESSIONE DI ESERCIZIO DELLE RUOTE



95065

- ATTENZIONE: NON METTERE MAI IN FUNZIONE L'ATOMIZZATORE SENZA LIQUIDO NEL SERBATOIO



95019

- ACQUA CHIARA



New Plus 42 - 45 - 50 - 55

## Safety decals



- STOP THE ENGINE AND REMOVE THE KEY FROM THE TRACTOR'S CONTROL PANEL BEFORE CARRYING OUT ALL MAINTENANCE OR REPAIR OPERATIONS
- CONSULT THE USER AND MAINTENANCE MANUAL BEFORE USING OR INTERVENING ON THE MACHINE

95001



- CONSULT THE USER AND MAINTENANCE MANUAL BEFORE USING THE MACHINE
- DANGER OF CONTAMINATION BY CONTACT OR POISONOUS PRODUCTS INHALATION
- IT IS FORBIDDEN TO GET INTO THE TANK!

95008



- DANGER OF SPRAYS: KEEP AT A SAFE DISTANCE
- DANGER, PARTS IN MOTION. BEFORE REMOVING PROTECTION GUARDS, STOP THE TRACTOR, REMOVE THE KEY FROM THE TRACTOR'S CONTROL PANEL AND ENSURE THAT ALL MOVING PARTS HAVE STOPPED

95009



- DANGER: MOUNT THE WHEELS AFTER HAVING HITCHED THE MACHINE TO THE HOISTER AND DISMANTLE THEM BEFORE UNHITCHING THE MACHINE FROM THE HOISTER (for the models where it is foreseen)

95012



- BEFORE UTILISING THE RELEASE DEVICE, STOP THE TRACTOR, REMOVE THE KEY FROM THE TRACTOR'S CONTROL PANEL AND ENSURE THAT THE FAN HAS STOPPED

95015



- MAXIMUM OPERATING SPEED OF THE DRIVE OUTLET (PTO): 540 RPM

95010



- DANGER: GLOVES MUST BE USED TO EMPTY THE TANK

95009

## Use and maintenance decals



- CHECK THE OIL LEVEL EVERY 8 HOURS: FAN SHAFT BEARINGS.

95079



- HANDWASHING TANK TAP Imprint next to the tap.

95057

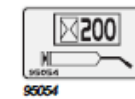

- GREASE EVERY 200 HOURS: FAN TIGHTENER SUPPORT AND FREEWHEEL

95054

New Plus 42 - 45 - 50 - 55

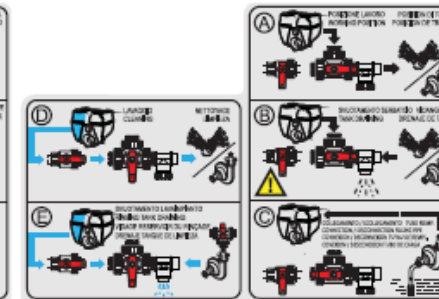
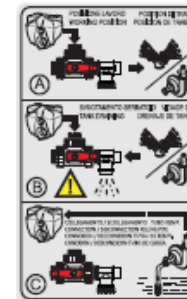

- INDICATION ON THE OPERATION OF THE 3-WAY TAP (P2) (and P15 for models on which it is foreseen)

95105

95104

95059



- INDICATION OF THE CHEMICAL EMPLOYED FOR THE TREATMENT

95102

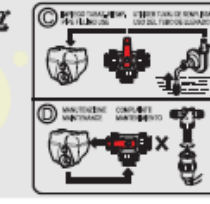
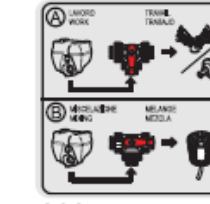

- INDICATION ON THE OPERATION OF THE 3-WAY TAP (P6)

95058

95065



- CLEAR WATER

95019



- INDICATION OF THE WHEELS OPERATING PRESSURE (accessory)

95056



- WARNING: NEVER OPERATE THE SPRAYER WITHOUT LIQUID IN THE TANK

95065



New Plus 42 - 45 - 50 - 55

## Autocollants pour la sécurité



95001

- ARRÊTER LE MOTEUR ET ENLEVER LA CLÉ DU TABLEAU DE COMMANDE DU TRACTEUR AVANT D'EXÉCUTER TOUTE OPÉRATION D'ENTRETIEN OU DE REPARATION.
- CONSULTER LE MANUEL "MODE D'EMPLOI ET ENTRETIEN" AVANT D'INTERVENIR SUR LA MACHINE.



95098

- CONSULTER LE MANUEL "MODE D'EMPLOI ET ENTRETIEN" AVANT D'UTILISER LA MACHINE.
- DANGER DE CONTAMINATION PAR CONTACT OU INHALATION DE PRODUITS TOXIQUES.
- ÉIL EST INTERDIT DE S'INTRODUIRE DANS LE RÉSERVOIR.



95099

- DANGER DE GICLÉES: SE TENIR À UNE DISTANCE DE SÉCURITÉ.
- DANGER D'ORGANES TOURNANTS. AVANT D'ENLEVER LES PROTECTIONS, ARRÊTER LE TRACTEUR, ENLEVER LA CLÉ DU TABLEAU DE COMMANDE ET S'ASSURER QUE LES ORGANES SE SOIENT ARRÊTÉS.



95012

- DANGER: MONTER LES ROUES APRÈS AVOIR ACCROCHÉ LA MACHINE AU DISPOSITIF DE SOULÈVEMENT ET LES DÉMONTÉ AVANT DE DÉCROCHER LA MACHINE DU MÊME DISPOSITIF. (Pour les versions où il est prévu)



95010

- VITESSE MAXIMUM DE MARCHÉ DE LA P.d.F.: 540 TOURS PAR MINUTE.



95015

- AVANT D'UTILISER LE DÉBRAYAGE, ARRÊTER LE TRACTEUR, ENLEVER LA CLÉ DU TABLEAU DE COMMANDE ET S'ASSURER QUE LE VENTILATEUR SOIT ARRÊTÉ.



95009

- DANGER: UTILISER DES GANTS POUR VIDER LE RÉSERVOIR.

## Autocollants pour l'emploi et l'entretien



95079

- VÉRIFIER LE NIVEAU DE L'HUILE CHAQUES 8 HEURES: ROUEMENTS DE L'ARBRE DU VENTILATEUR.



95057

- ROBINET DU RÉSERVOIR LAVE-MAINS  
Imprimé sur le côté du réservoir, près du robinet.

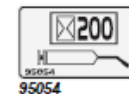

95054

- GRAISSER TOUTES LES 200 HEURES: ROUEMENTS DE L'ARBRE DU VENTILATEUR ET ROUE LIBRE.

New Plus 42 - 45 - 50 - 55



95105

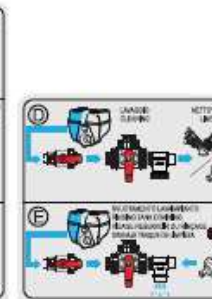

95104

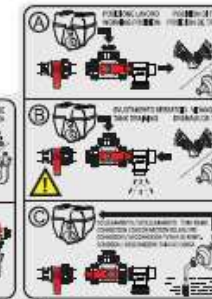

95059

- INDICATIONS SUR LE FONCTIONNEMENT DU ROBINET À 3 VOIES (P2) (et du robinet de rinçage P15 pour les versions où il est prévu)

- POINT D'ACCROCHAGE POUR LE SOULÈVEMENT DE LA MACHINE.



95102

- INDICATION DE PRODUIT EMPLOYÉ POUR LE TRAITEMENT

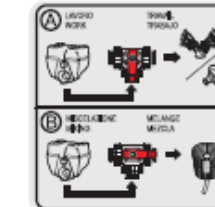

95058



95058

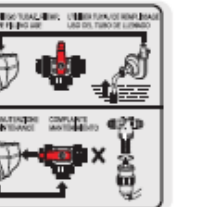

95058

- INDICATIONS SUR LE FONCTIONNEMENT DU ROBINET À 3 VOIES (P6).



95019

EAU CLAIRE

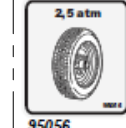

95056

- INDICATION DE LA PRESSION DE MARCHÉ DES ROUES. (Accessoire)



95065

- ATTENTION: NE FAIRE JAMAIS FONCTIONNER LE PULVERISATEUR PNEUMATIQUE SANS DU LIQUIDE DANS LE RÉSERVOIR.

Gli esplosi elencati di seguito sono relativi  
a varianti o accessori a richiesta

The exploded drawings listed below are related  
to different versions or optional accessories

Le vues éclatées suivantes sont relatives  
à des variantes ou à des accessoires optionnels

Dibujos de vista despiezada son relativos a  
variantes o accesorios opcionales

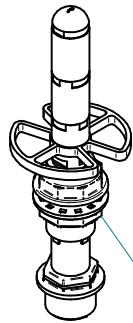

KIT.LAV.BOX

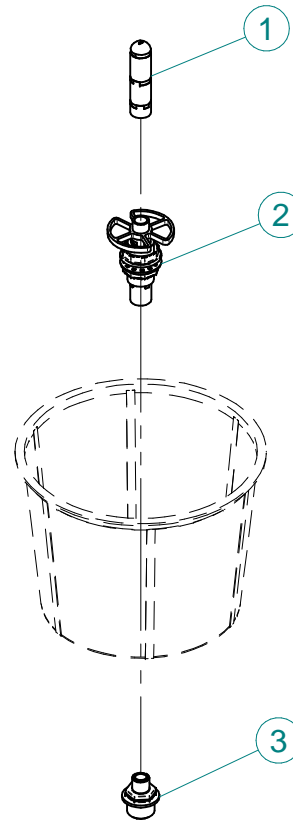

N°	Doc. Number	Titolo	Title	Q.tà
1	X21.190.000	VALVOLA PER TESTINA LAVAGGIO CONTENITORE	VALVE HEAD CONTAINER WASHING	1
2	X21.191.000	TESTINA ROTANTE LAVAGGIO CONTENITORE	ROTATING HEAD CONTAINER WASHING	1
3	X21.410.000	NIPPLO 1/2M - 1M	NIPPLE 1/2M - 1M	1

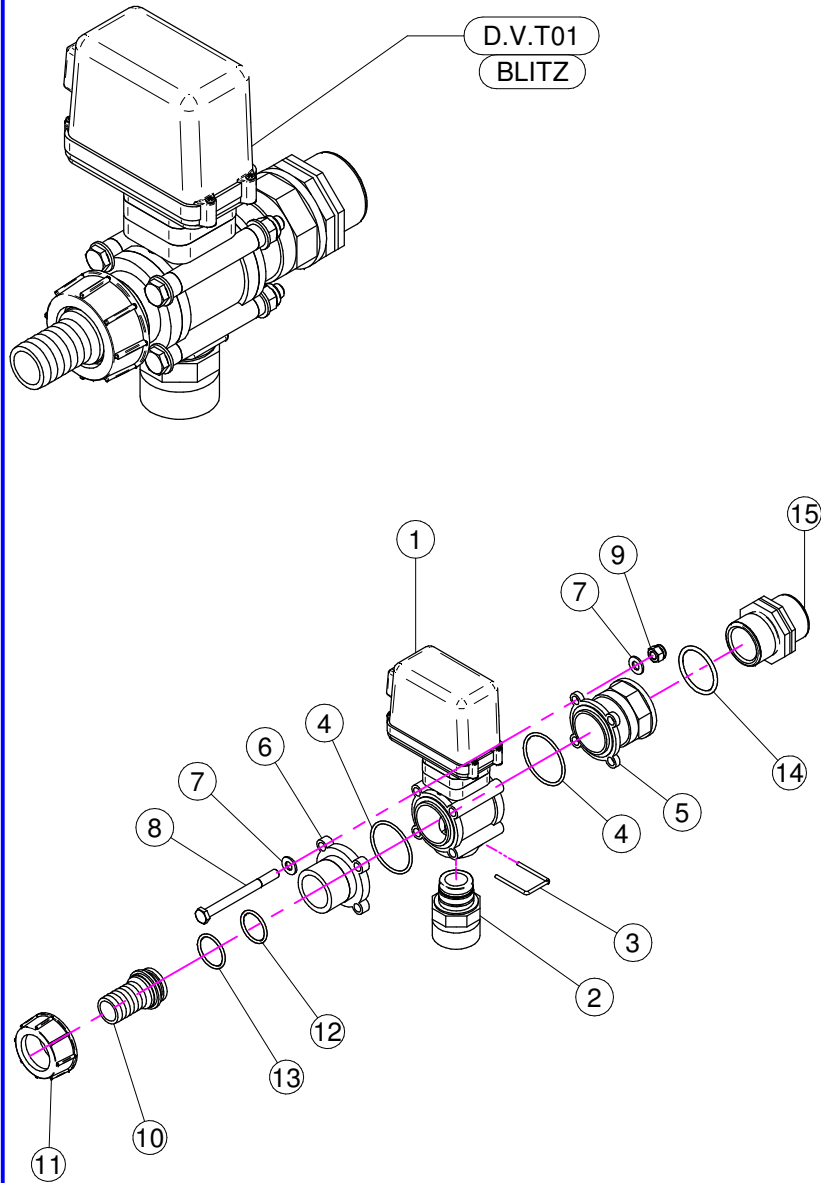

D.V.T01  
 BLITZ

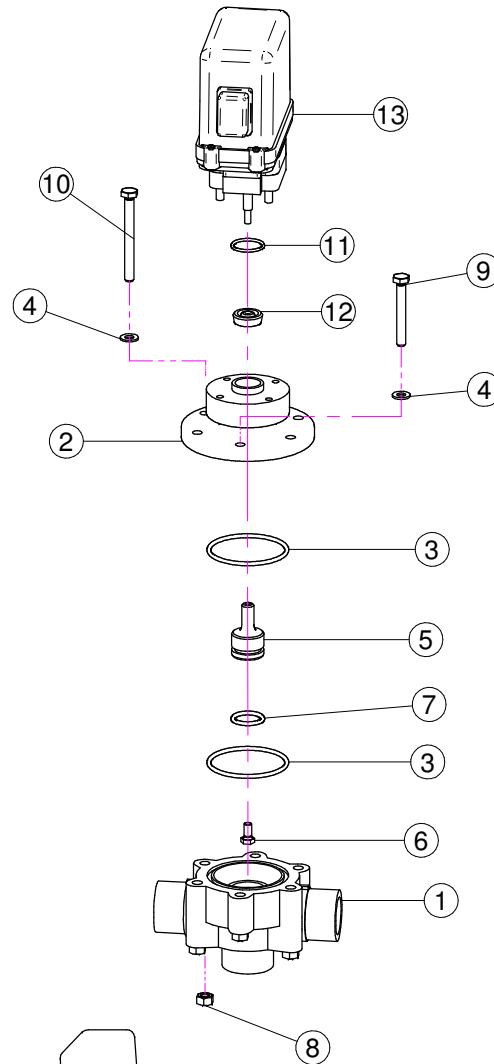

D.V.P01  
 PLUS

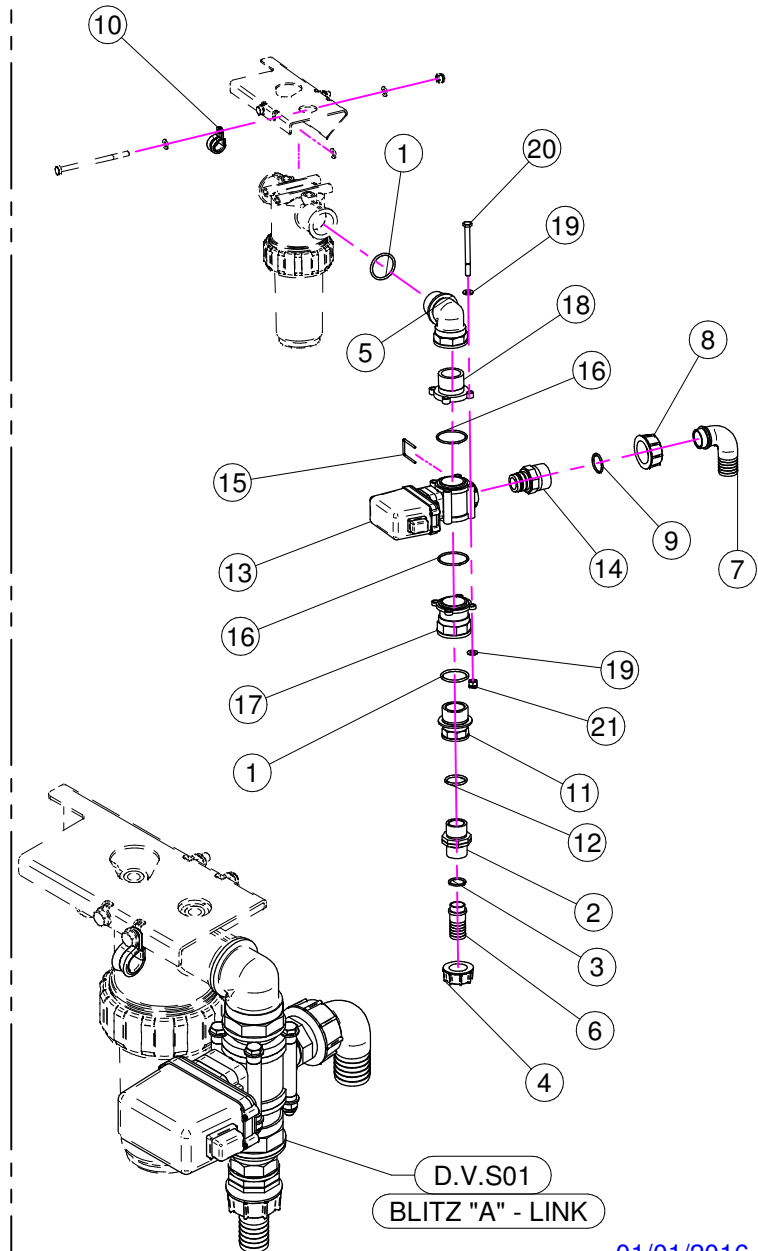

D.V.S01  
 BLITZ "A" - LINK

## D.V.T01 (BLITZ)

N°	Doc. Number	Titolo	Title	Q.tà	Note
1	X21.130.000	VALVOLA MOTORIZZATA PROPORZIONALE	ELECTRIC PROPORTIONAL VALVE	1	
2	X21.131.000	RIDUZIONE ATT.RAP. G 1" 1/4	REDUCTION J. F. G 1" 1/4	1	
3	X21.130.005	FORCHETTA ATTACCO RAPIDO	FORK FASTNER JOINT	1	
4	XOR.003.181	OR D. 45,69x50,93x2,62	45,69x50,93x2,62 O-RING	2	
5	X21.133.000	RACCORDO FLANGIATO 1" - 1 1/4"	CONNECTOR	1	
6	X21.132.000	FLANGIA VALVOLE	VALVE FLANGE	1	
7	XRP.008.000	RONDELLA PIANA D.8	WASHER D.8	8	
8	XTE.008.090	VITE TE M8 x 90	SCREW TE M8 x 90	4	
9	XDA.008.0AG	DADO AUTOBLOCCANTE M8	SELF LOCKING NUT M8	4	
10	X02.363.000	RACCORDO DIRITTO PG D.25 - 1 1/4	STRAIGHT HOSE R.H D.25 - 1 1/4	1	
11	X00.058.006	GIRELLO 1" 1/4 GAS	1" 1/4 FLY NUT	1	
12	XOR.003.106	OR D.26.65x2.62	O-RING D.26.65x2.62	1	
13	XOR.003.112	OR D.28,24x2,62	O-RING D.28,24x2,62	1	
14	XOR.000.144	OR D.39,69x3,53	O-RING D.39,69x3,53	1	
15	X00.345.010	NIPPLO 1" 1/4 + 1" 1/4 GAS	NIPPLE 1" 1/4 + 1" 1/4 GAS	1	

## D.V.S01 (BLITZ "A" - LINK)

N°	Doc. Number	Titolo	Title	Q.tà	Note
1	XOR.000.144	OR D.39,69x3,53	O-RING D.39,69x3,53	2	
2	X00.055.034	NIPPLO 1" / 1" GAS	NIPPLE 1" / 1" GAS	1	
3	XOR.000.132	OR D.23,81 x 2,62	23,81 x 2,62 O-RING GASKET	1	
4	X00.055.24.2	GIRELLO 1" GAS	1" FLY NUT	1	
5	X24.070.000	RACCORDO CURVO M-F 1"1/4	HOSETAIL 1"1/4	1	
6	X00.055.021	RACCORDO DIRITTO PG D.25	STRAIGHT HOSE R.H D.25	1	
7	X00.058.004	RACCORDO CURVO P.G. D.30	D.30 HOSETAIL	1	
8	X00.058.006	GIRELLO 1" 1/4 GAS	1" 1/4 FLY NUT	1	
9	XOR.003.112	OR D.28,24x2,62	O-RING D.28,24x2,62	1	
10	XFG.018.000	FASCETTA GOMMATA PER TUBI D.18	STICKER	1	
11	X02.374.000	RIDUZIONE M/F 1"F / 1"1/4M	M. / F. 1"F / 1"1/4M REDUCTION	1	
12	XOR.004.118	OR D.29,75 x 3,53	29,75 x 3,53 O-RING GASKET	1	
13	X21.130.000	VALVOLA MOTORIZZATA PROPORZIONALE	ELECTRIC PROPORTIONAL VALVE	1	
14	X21.131.000	RIDUZIONE ATT.RAP. G 1" 1/4	REDUCTION J. F. G 1" 1/4	1	
15	X21.130.005	FORCHETTA ATTACCO RAPIDO	FORK FASTNER JOINT	1	
16	XOR.003.181	OR D. 45,69x50,93x2,62	45,69x50,93x2,62 O-RING	2	
17	X21.133.000	RACCORDO FLANGIATO 1" - 1 1/4"	CONNECTOR	1	
18	X21.132.000	FLANGIA VALVOLE	VALVE FLANGE	1	
19	XRP.008.000	RONDELLA PIANA D.8	WASHER D.8	8	
20	XTE.008.090	VITE TE M8 x 90	SCREW TE M8 x 90	4	
21	XDA.008.0AG	DADO AUTOBLOCCANTE M8	SELF LOCKING NUT M8	4	

## D.V.P01 (PLUS)

N°	Doc. Number	Titolo	Title	Q.tà
1	X02.447.001	CORPO VALVOLA DI REGOLAZIONE	BODY FOR REGULATION VALVE	1
2	X50.417.000	SEMICORPO VALVOLA DI REGOLAZIONE ELETTRICA	BODY PART FOR ELECTRIC CONTROL	1
3	XOR.003.193	OR D.48,89x2,62	O-RING GASKET 48,89x2,62	2
4	XRP.006.000I	RONDELLA PIANA D. 6 INOX	INOX WASHER D.6	6
5	X50.416.000	PERNO PER VALVOLA DI REGOLAZIONE PROP.	VALVE PLUG	1
6	XTE.005.010I	VITE TE M5 x 10	SCREW TE M5 X 10	1
7	XOR.003.068	OR D.17,12x2,62	O-RING GASKET 17,12x2,62	1
8	XDO.06.5588GI	DADO M6 6S PG INOX	INOX M6 6S BIG LEAD NUT 5588	6
9	XTE.006.045I	VITE TE M6x45 INOX	INOX M6x45 SCREW	2
10	XTE.006.060I	VITE TE M6x60 INOX	INOX M6x60 TE SCREW	4
11	XOR.002.075V	OR D.18.77 X 1.78 VITON	D.18.77 X 1.78 O-RING VITON	1
12	X02.390.008	GUARNIZIONE D.6x17x6 VITON	GASKET	1
13	X21.130.100A	VALVOLA REGOLAZIONE PROP. ELETTRICA VELOCE	QUICK ELECTRIC VALVE	1



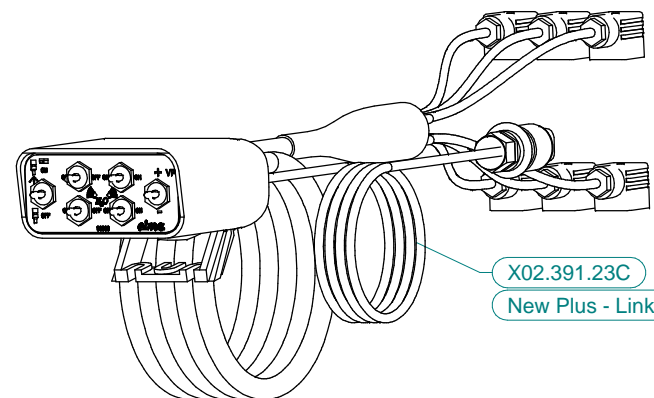
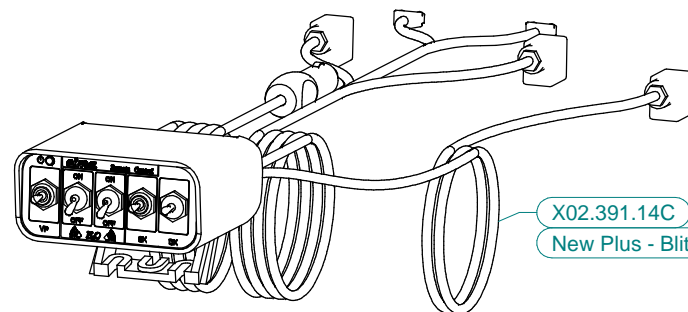
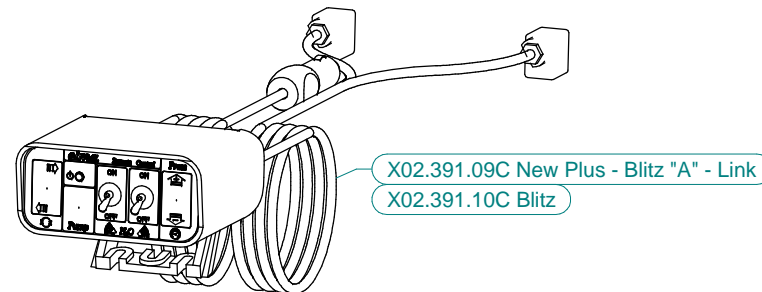
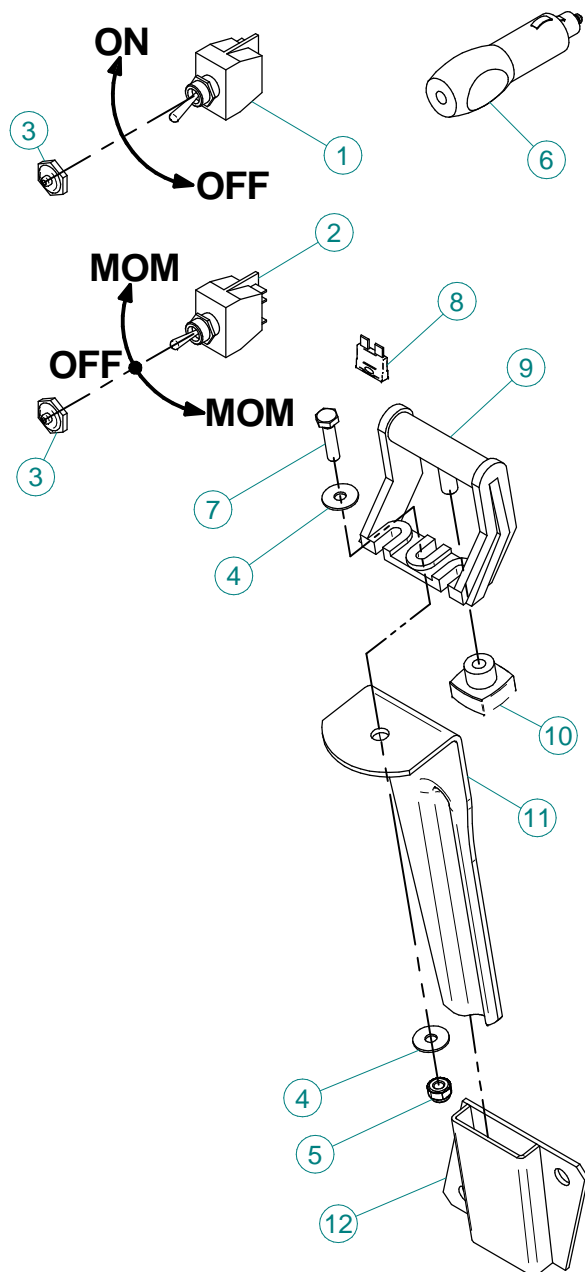

## X02.391.09C /10C / 14C / 15C / 22C

N°	Doc. Number	Titolo	Title	Q.tà	Note
1	X21.030.005	DEVIATORE 2V 2P ON-OFF 10A	SWITCH 2V 2P ON-OFF 10A	1	
2	X21.030.006	DEVIATORE MOM - 0 - MOM 10A	SWITCH MOM - 0 - MOM 10A	1	
3	X21.030.007	CAPPUCCIO INTERRUTTORE D.12	SWITCH CAP D.12	2	
4	XRP.006.018	RONDELLA PIANA D. 6x18	WASHER D.6x18	2	
5	XDA.006.0AG	DADO AUTOBLOCCANTE M6 ALTO PG	SELF-LOCKING NUT - HIGH M6	1	
6	X21.030.008	CONNETTORE DI ALIMENTAZIONE 12V	12V POWER JACK	1	
7	XTE.006.025T	VITE TE M6X25	SCREW TE M6X25	1	
8	X21.030.004	FUSIBILE - 10 Ah	10 Ah FUSE	1	
9	X21.030.002	STAFFA DI FISSAGGIO MOBILE	MOVING FIXING BRACKET	1	
10	X21.030.003	POMELLO DI BLOCCAGGIO	FIXING KNOB	1	
11	X20.111.000	STAFFA PORTA BAIONETTA	BRACKET	1	
12	X20.107.000	SUPPORTO A BAIONETTA FEMMINA	FEMALE BAYONET SUPPORT	1	

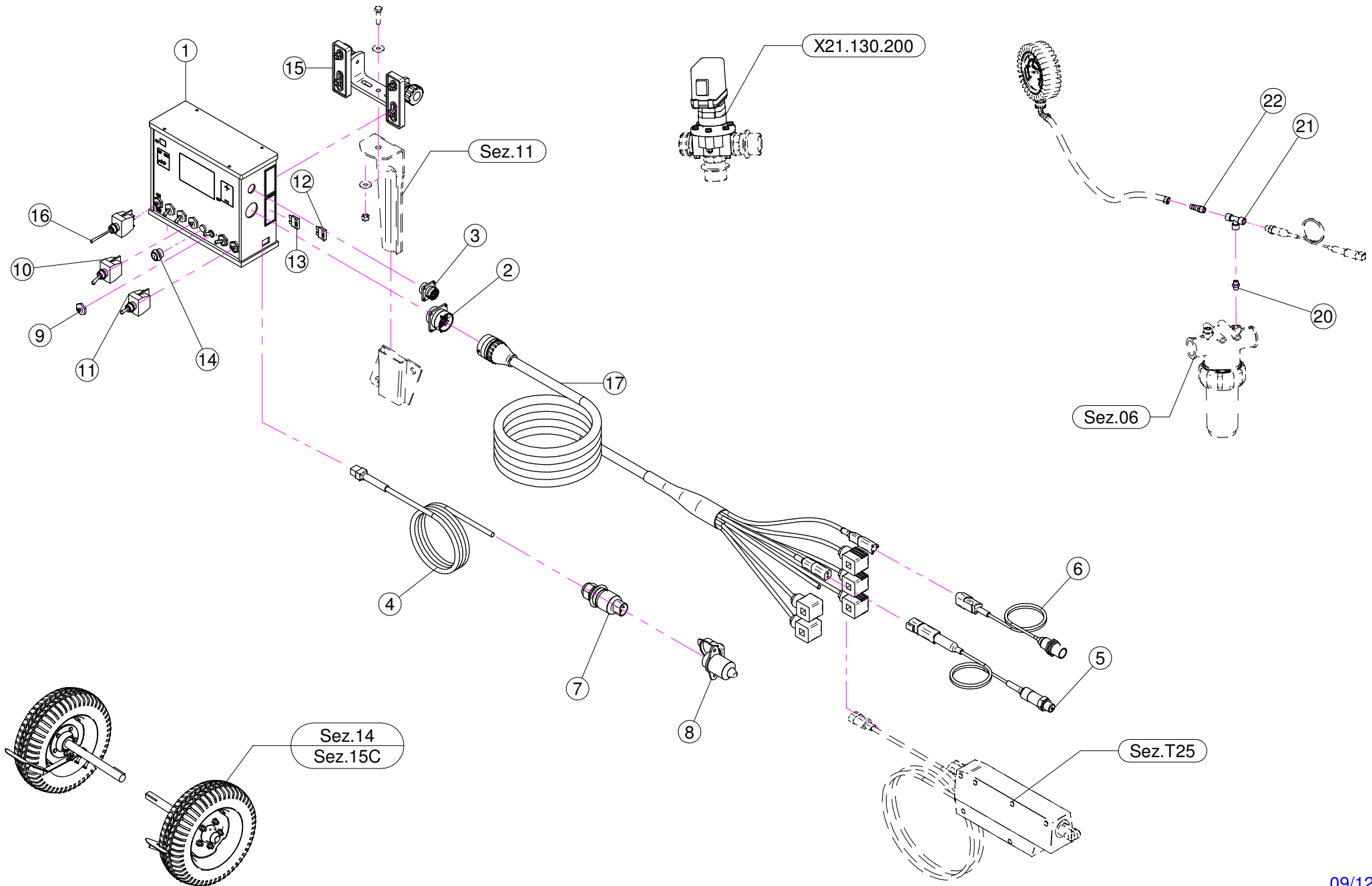

N°	Doc. Number	Titolo	Title	Q.tà	Note
1	X21.138.200	COMPUTER SERIE 844 AB	COMPUTER SERIES 844 AB	1	
2	X21.166.000	CONNETTORE BURNDY 28 PIN	BURNDY 28 PIN CONNECTOR	1	
3	X21.167.000	CONNETTORE BURNDY 8 PIN	BURNDY 8 PIN CONNECTOR	1	
4	X21.161.000	CAVO DI ALIMENTAZIONE COMPUTER	COMPUTER POWER WIRE	1	
5	X21.140.000	TRASDUTTORE DI PRESSIONE 0-10 BAR	PRESSURE TRANSDUCER	1	
6	X21.139.000	SENSORE DI VELOCITA' CL5X	SPEED SENSOR	1	
7	X21.162.000	SPINA DI ALIMENTAZIONE CAVO TRIPOLARE	POWER PLUG	1	
8	X21.163.000	PRESA DI ALIMENTAZIONE TRIPOLARE	POWER PLUG	1	
9	X21.030.007	CAPPUCCIO INTERRUTTORE D.12	SWITCH CAP D.12	7	
10	X21.030.005	DEVIATORE 2V 2P ON-OFF 10A	SWITCH 2V 2P ON-OFF 10A	5	
11	X21.030.006	DEVIATORE MOM - 0 - MOM 10A	SWITCH MOM - 0 - MOM 10A	1	
12	X21.030.004	FUSIBILE - 10 Ah	10 Ah FUSE	1	
13	X21.168.000	FUSIBILE - 5 Ah	5 Ah FUSE	1	
14	X21.170.000	INTERRUTTORE PULSANTE 2V 2P ON - OFF	PUSH-BUTTON SWITCH 2V 2P ON - OFF	1	
15	X21.165.000	STAFFA DI FISSAGGIO	BRACKET	1	
16	X21.030.018	DEVIATORE LUNGO 2V 2P ON-OFF 10A	LONG SWITCH 2V 2P ON-OFF 10A	1	
17	X21.142.100	CAVO DATI COMPUTER	COMPUTER DATA CABLE	1	

N°	Doc. Number	Titolo	Title	Q.tà	Note
20	X24.004.000	NIPPLO M/M 1/4"	NIPLES M/M 1/4"	1	
21	X21.172.000	RACCORDO A T 1/4" F/F/F	T FITTING 1/4" F/F/F	1	
22	X00.414.000	PORTAGOMMA D.11 1/4" M. FORATO	STRAIGHT HOSE D.11 1/4"	1	

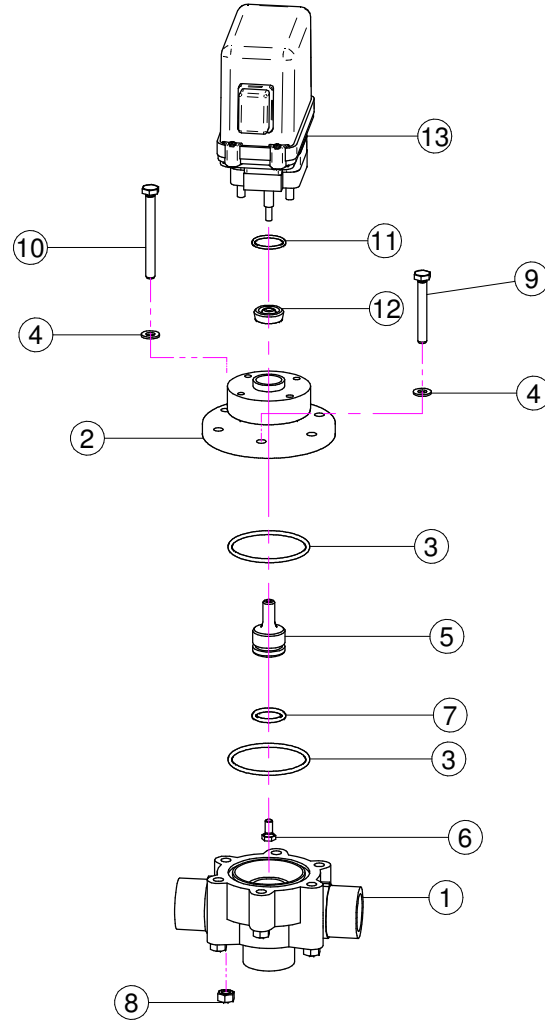
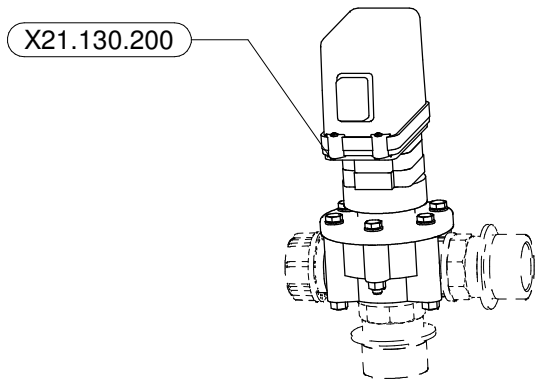

N°	Doc. Number	Titolo	Title	Q.tà
1	X02.447.001	CORPO VALVOLA DI REGOLAZIONE	BODY FOR REGULATION VALVE	1
2	X50.417.000	SEMICORPO VALVOLA DI REGOLAZIONE ELETTRICA	BODY PART FOR ELECTRIC CONTROL	1
3	XOR.003.193	OR D.48,89x2,62	O-RING GASKET 48,89x2,62	2
4	XRP.006.000I	RONDELLA PIANA D. 6 INOX	INOX WASHER D.6	6
5	X50.416.000	PERNO PER VALVOLA DI REGOLAZIONE PROP.	VALVE PLUG	1
6	XTE.005.010I	VITE TE M5 x 10	SCREW TE M5 X 10	1
7	XOR.003.068	OR D.17,12x2,62	O-RING GASKET 17,12x2,62	1
8	XDO.06.5588GI	DADO M6 6S PG INOX	INOX M6 6S BIG LEAD NUT 5588	6
9	XTE.006.045I	VITE TE M6x45 INOX	INOX M6x45 SCREW	2
10	XTE.006.060I	VITE TE M6x60 INOX	INOX M6x60 TE SCREW	4
11	XOR.002.075V	OR D.18.77 X 1.78 VITON	D.18.77 X 1.78 O-RING VITON	1
12	X02.390.008	GUARNIZIONE D.6x17x6 VITON	GASKET	1
13	X21.130.100A	VALVOLA REGOLAZIONE PROP. ELETTRICA VELOCE	QUICK ELECTRIC VALVE	1

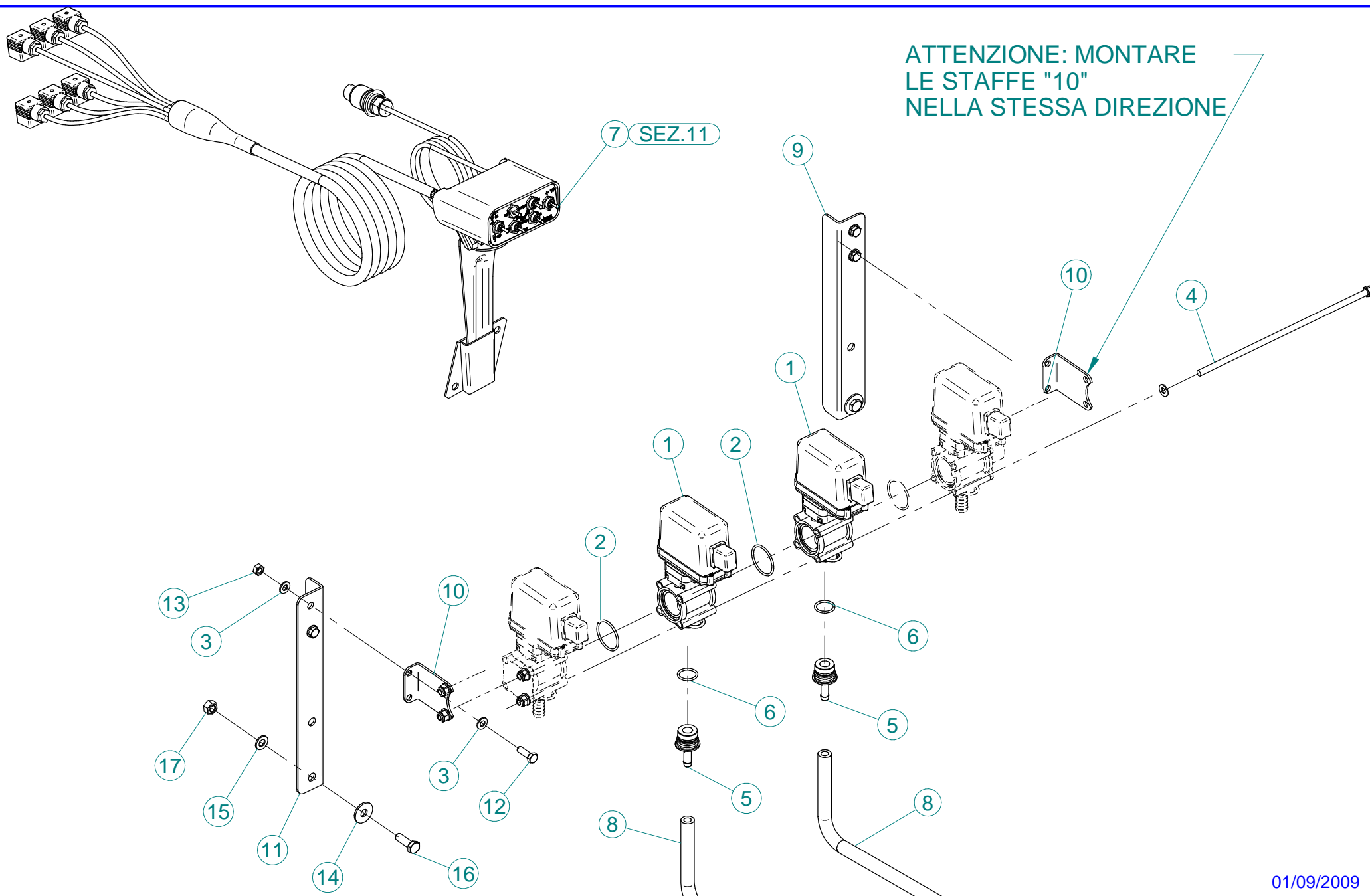

N°	Doc. Number	Titolo	Title	Q.tà
1	X02.390.029	ELETTROVALVOLA COMPLETA ARAG BLU	SOLENOID VALVE	2
2	XOR.003.156	OR D.39,34x2,62	O-RING GASKET 39,34x2,62	2
3	XRP.008.000	RONDELLA PIANA D.8	WASHER D.8	8
4	X40.385.000	TONDO FILETTATO M8 L=350 CON DADO	THREADED ROUND M8 WITH NUT	4
5	X02.390.035	RACCORDO PTG D.10	HOSETAIL D.10	2
6	XOR.000.130	OR D.22,22 x 2,62	22,22 x 2,62 O-RING GASKET	2
7	X21.330.000	KIT COMANDO ELETTRICO A 4 VIE	KIT FOR CONTROL SOLENOID VALVE 4 WAYS	1
8	X02.213.150	TUBO D.10 L=1500	HOSE D.10 L=1500	2
9	X40.452.000	STAFFA PER 4 ELETTROVALVOLE DX	4 ELECTROVALVES BRACKET (RIGHT)	1
10	X40.453.000	STAFFA ARAG PER ELETTROVALVOLE	ARAG BRACKET FOR ELECTROVALVES	2
11	X40.451.000	STAFFA PER 4 ELETTROVALVOLE SX	4 ELECTROVALVES BRACKET (LEFT)	1
12	XTE.008.025T	VITE TE M8 x 25	SCREW TE M8 x 25	4
13	XD0.08.5587G	DADO M8 PG 5587	NUT M8	4
14	XRP.010.030	RONDELLA PIANA D.10 x 30 mm	WASHER D.10 x 30 mm	2
15	XRP.010.000	RONDELLA PIANA D.10	WASHER D.10	2
16	XTE.010.030T	VITE TE M10 x 30	SCREW TE M10 x 30	2
17	XD0.10.5587G	DADO M10	NUT M10	2



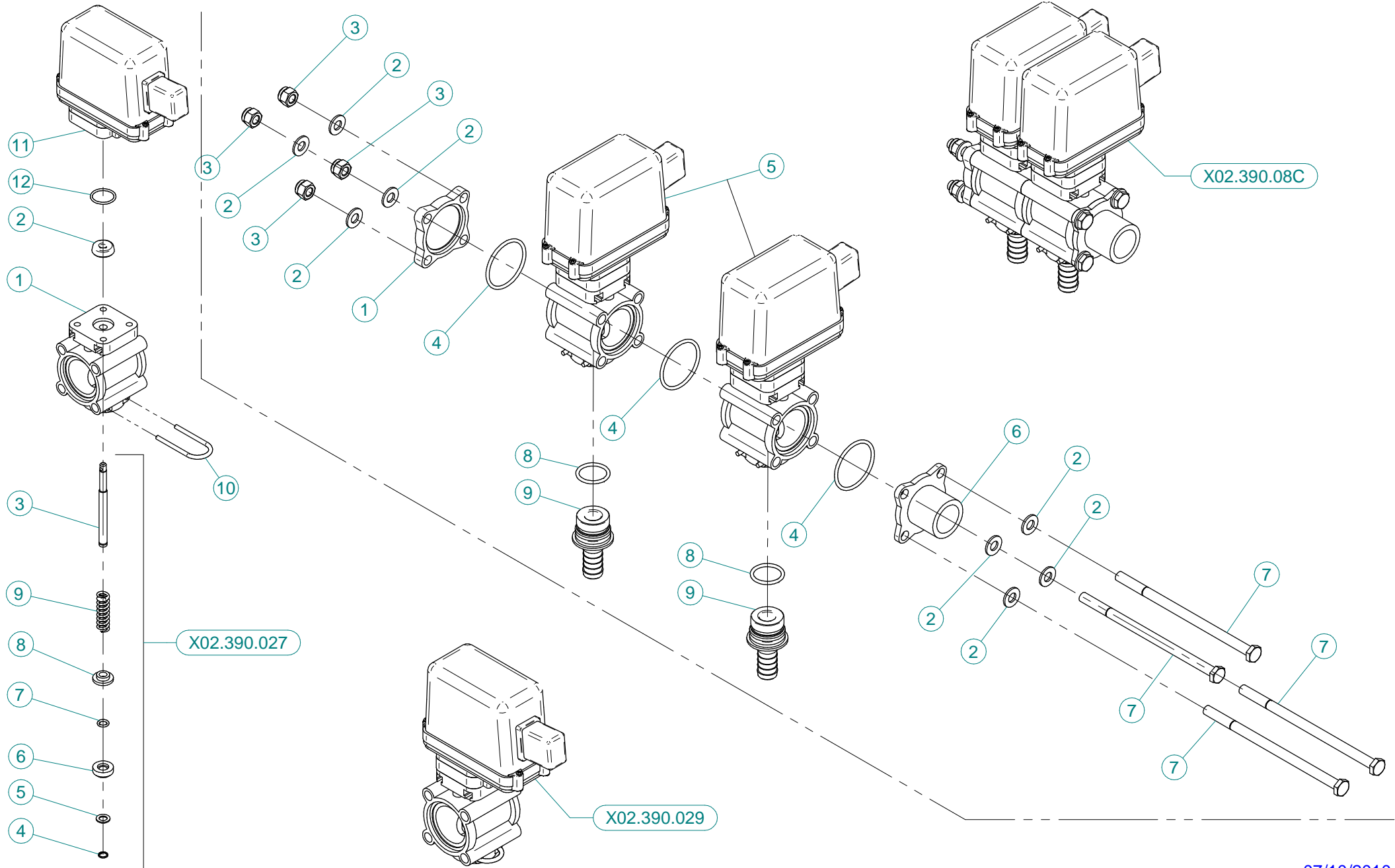

**X02.390.029**

N°	Doc. Number	Titolo	Title	Q.tà	Note
1	X02.390.007	CORPO VALVOLA	VALVE BODY	1	
2	X02.390.008	GUARNIZIONE D.6x17x6 VITON	GASKET	1	
3	X02.390.020	PERNO VALVOLA MANUALE INOX	PIN	1	
4	X02.390.013	ANELLO ARRESTO	STOP RING	1	
5	X02.390.014	RONDELLA PIANA 7,2 x 12 INOX	WASHER 7,2 x 12 INOX	1	
6	X02.390.015	PIATTELLO INFERIORE VALVOLA	LOWER PIATTELLO VALVE	1	
7	X02.390.016	OR 6,7 x 1,78	O RING	1	
8	X02.390.009	PIATTELLO SUPERIORE VALVOLE	SUPERIOR PIATTELLO VALVES	1	
9	X02.390.011	MOLLA DI RITEGNO	SPRING	1	
10	X21.130.005	FORCHETTA PER RUB. MAN. SEMP. PR	FORK	1	
11	X02.390.028	ELETTROVALVOLA COMPLETA ARAG BLU	SOLENOID VALVE	1	
12	XOR.002.075	OR D.18.77 X 1.78	D.18.77 X 1.78 O-RING	1	

**X02.390.08C**

N°	Doc. Number	Titolo	Title	Q.tà	Note
1	X02.390.017	FLANGIA VALVOLE	VALVE FLANGE	1	
2	XRP.008.000	RONDELLA PIANA D.8	WASHER D.8	8	
3	XDA.008.0AG	DADO AUTOBLOCCANTE M8	SELF LOCKING NUT M8	4	
4	XOR.003.156	OR D.39,34x2,62	O-RING GASKET 39,34x2,62	3	
5	X02.390.029	ELETTROVALVOLA COMPLETA ARAG BLU	SOLENOID VALVE	2	
6	X02.390.018	RACCORDO FLANGIATO 1" GAS	CONNECTOR	1	
7	XTE.008.150	VITE TE M8x150	SCREW TE M8 x 150	4	
8	XOR.000.130	OR D.22,22 x 2,62	22,22 x 2,62 O-RING GASKET	2	
9	X02.406.000	PORTAGOMMA D.16 ATT.RAP. PER ELETT.	HOSETAIL D.16	2	

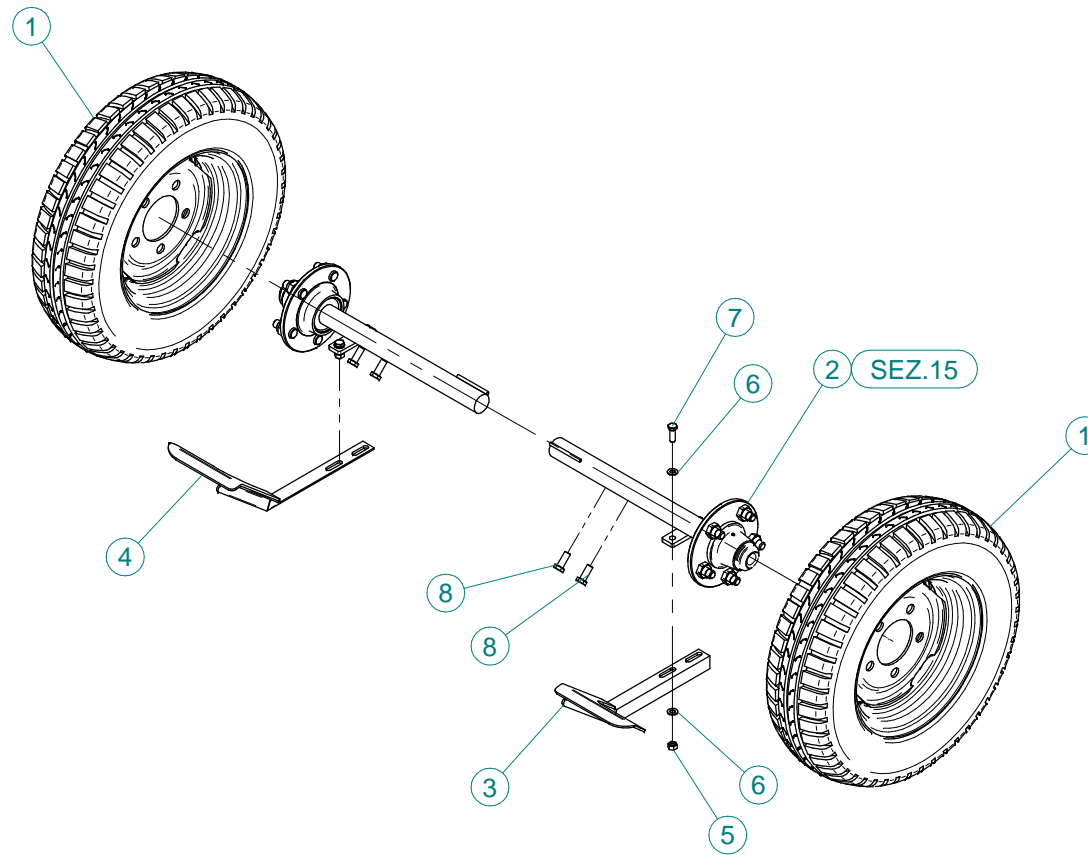

N°	Doc. Number	Titolo	Title	Q.tà
1	X04.673.000	RUOTA 135/80 - 13 5F TL	WHEELS AND TIRES	2
2	X04.680.000	SEMIASSE Ø 40x400	AXLE SHAFT Ø 40x400	2
3	X20.758.001	RASCHIA FANGO DX	TAKE AWAY MUD DX	1
4	X20.758.002	RASCHIA FANGO SX	TAKE AWAY MUD SX	1
5	XD0.10.5587G	DADO M10 6S PG 5587 ZINC.	M10 6S BIG LEAD NUT 5587	4
6	XRP.010.000	RONDELLA PIANA D.10 6592 ZINC.	WASHER Ø 10	8
7	XTE.010.030T	VITE TE UNI 5739-65 M10x30-8.8	SCREW TE UNI 5739-65 M10x30-8.8	4
8	XTE.012.030T	VITE TE UNI 5739-65 M12x30-8.8	SCREW TE UNI 5739-65 M12x30-8.8	4

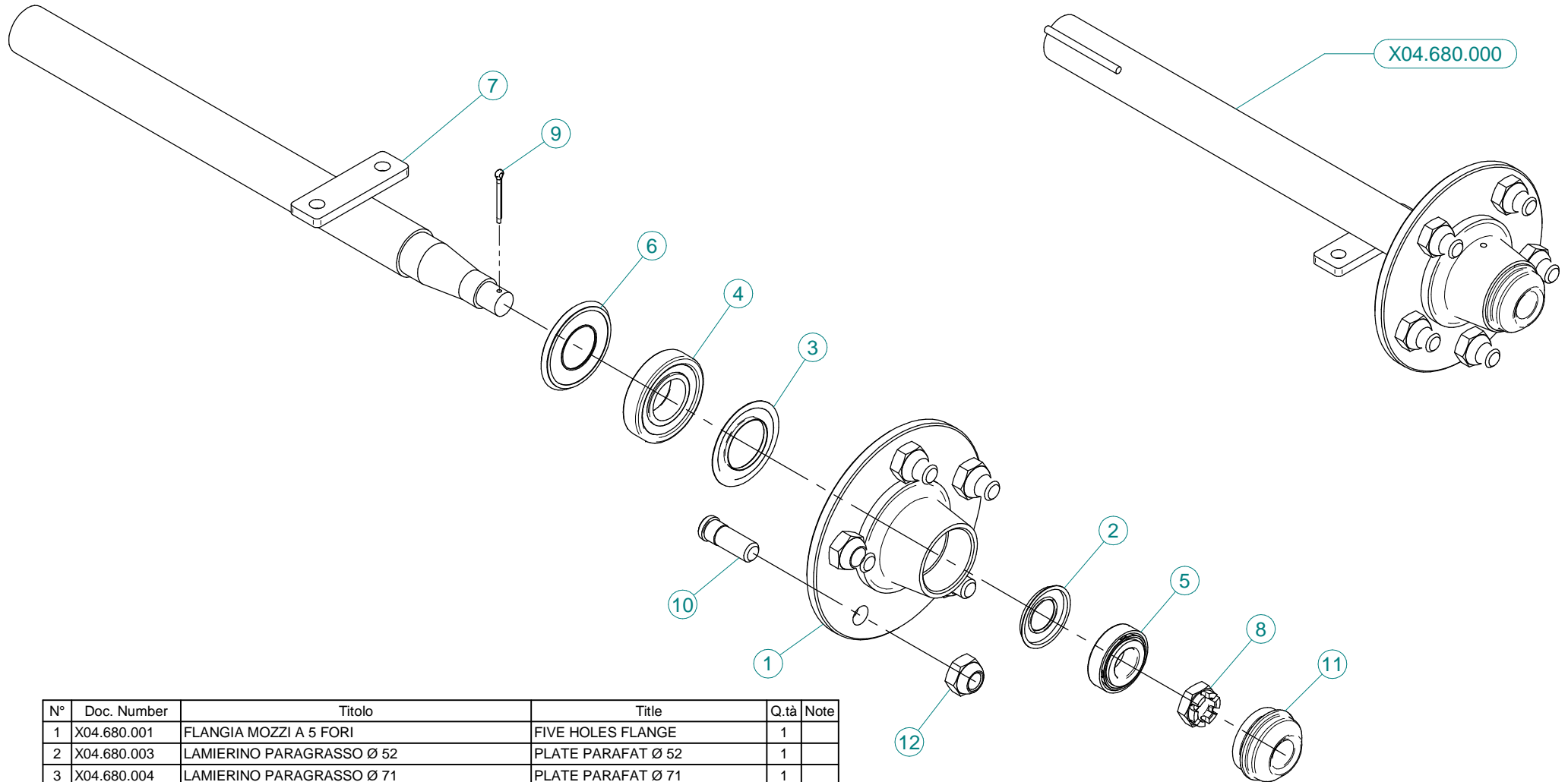

N°	Doc. Number	Titolo	Title	Q.tà	Note
1	X04.680.001	FLANGIA MOZZI A 5 FORI	FIVE HOLES FLANGE	1	
2	X04.680.003	LAMIERINO PARAGRASSO Ø 52	PLATE PARAFAT Ø 52	1	
3	X04.680.004	LAMIERINO PARAGRASSO Ø 71	PLATE PARAFAT Ø 71	1	
4	XK0.030.207	CUSCINETTO A UNA CORONA DI RULLI CONICI	BEARING	1	
5	XK0.030.205	CUSCINETTO A UNA CORONA DI RULLI CONICI	TAPERED ROLLER BEARING	1	
6	X20.464.000	PARAOLIO Ø 35x72 IN GOMMA	DUST SHIELDER	1	
7	X04.680.002	SEMIASSE	AXLE SHAFT	1	
8	XDI.020.5593F	DADO UNI 5594 - M20x1,5-6S	NUT UNI 5594 - M20x1,5-6S	1	
9	X20.259.000	COPIGLIA Ø 4 L=45 PER MOZZI	SPLIT PIN	1	
10	X04.681.000	COLONNETTA PER SEMIASSE M16x1,5	STUD M16x1,5	5	
11	X04.597.002	COPERCHIETTO DI CHIUSURA	COVER	1	
12	X04.682.000	DADO PER COLONNETTA M 16x1,5	SPECIAL NUT	5	

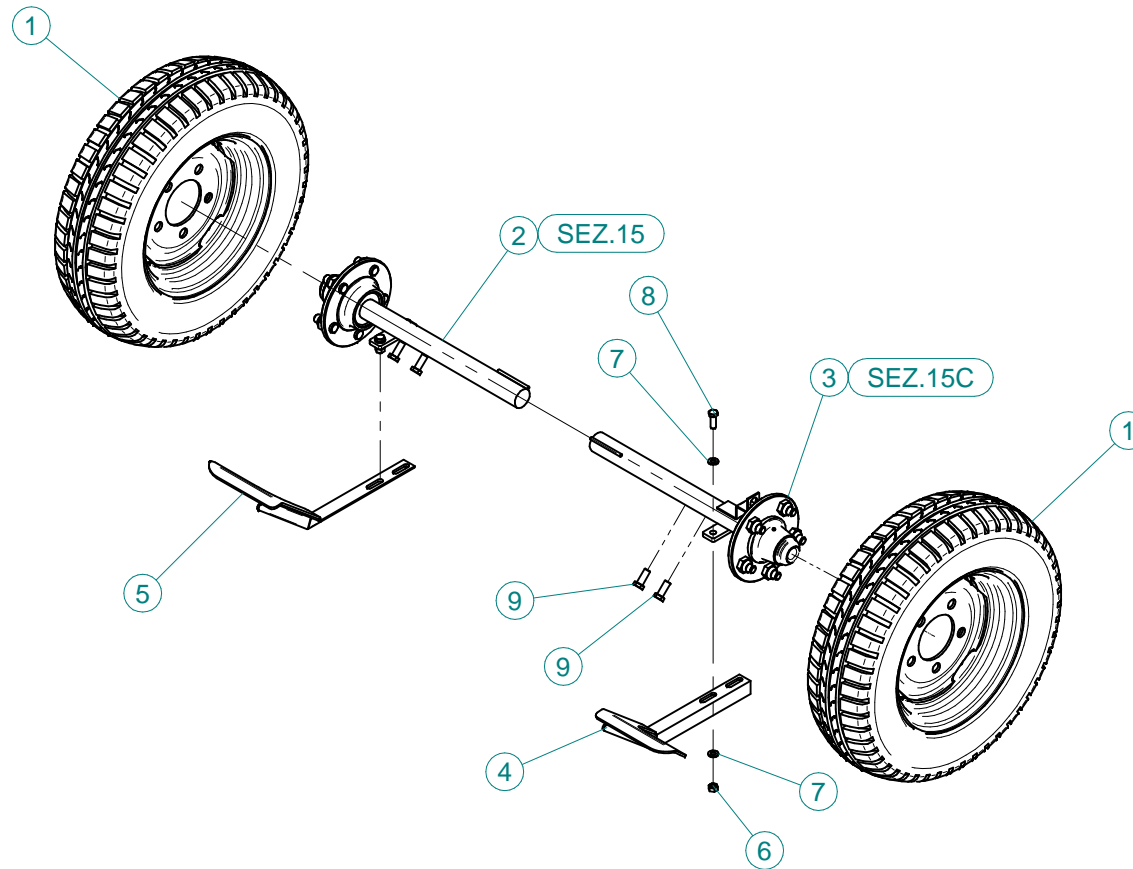

N°	Doc. Number	Titolo	Title	Q.tà
1	X04.673.000	RUOTA 135/80 - 13 5F TL	WHEELS AND TIRES	2
2	X04.680.000	SEMIASSE Ø 40x400	AXLE SHAFT Ø 40x400	1
3	X04.680.100	SEMIASSE D.40x400 EPA	AXLE SHAFT D.40x400 EPA	1
4	X20.758.001	RASCHIA FANGO DX	TAKE AWAY MUD DX	1
5	X20.758.002	RASCHIA FANGO SX	TAKE AWAY MUD SX	1
6	XD0.10.5587G	DADO M10 6S PG 5587 ZINC.	M10 6S BIG LEAD NUT 5587	4
7	XRP.010.000	RONDELLA PIANA D.10 6592 ZINC.	WASHER Ø 10	8
8	XTE.010.030T	VITE TE UNI 5739-65 M10x30-8.8	SCREW TE UNI 5739-65 M10x30-8.8	4
9	XTE.012.030T	VITE TE UNI 5739-65 M12x30-8.8	SCREW TE UNI 5739-65 M12x30-8.8	4

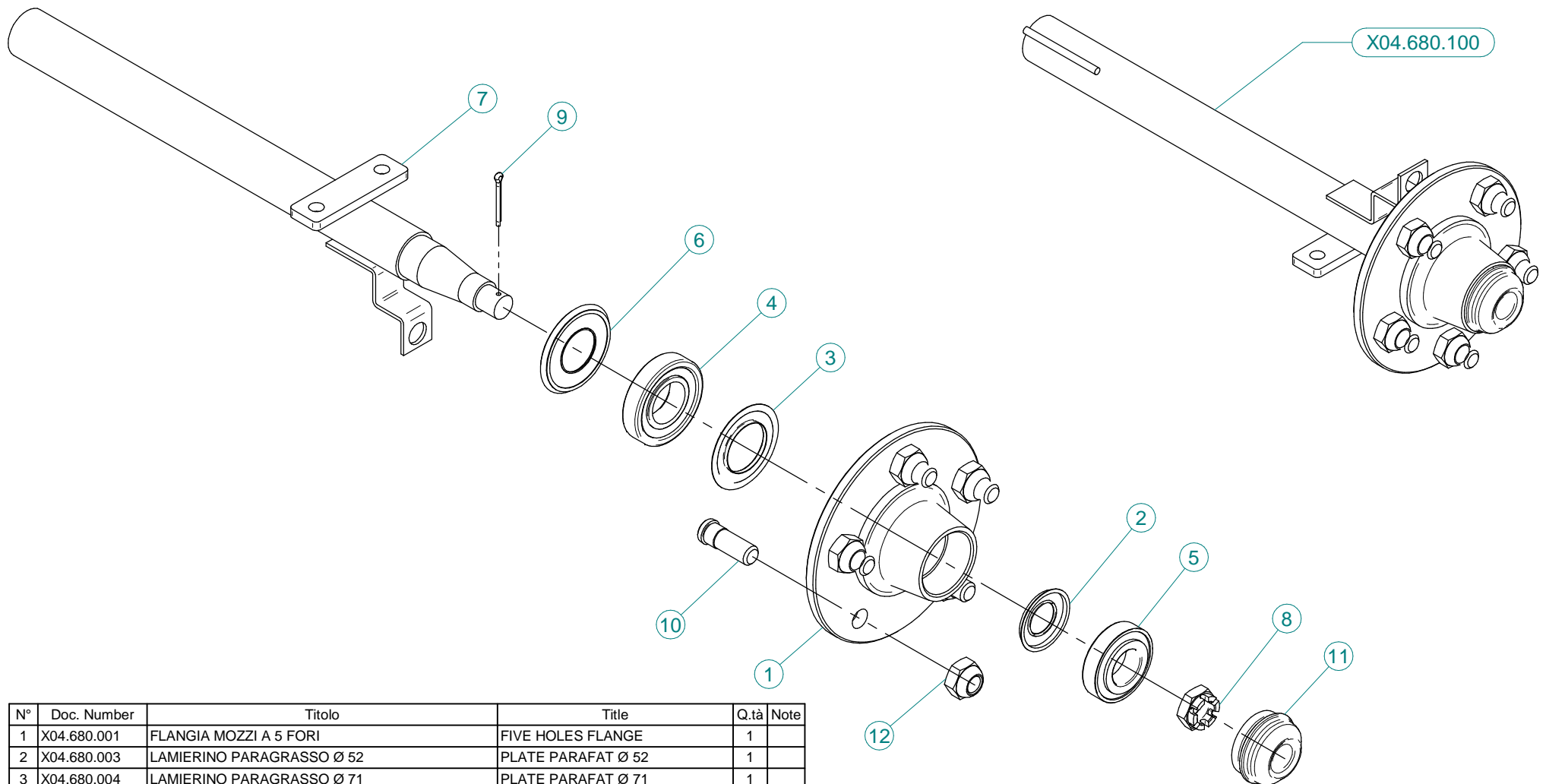

N°	Doc. Number	Titolo	Title	Q.tà	Note
1	X04.680.001	FLANGIA MOZZI A 5 FORI	FIVE HOLES FLANGE	1	
2	X04.680.003	LAMIERINO PARAGRASSO Ø 52	PLATE PARAFAT Ø 52	1	
3	X04.680.004	LAMIERINO PARAGRASSO Ø 71	PLATE PARAFAT Ø 71	1	
4	XK0.030.207	CUSCINETTO A UNA CORONA DI RULLI CONICI	BEARING	1	
5	XK0.030.205	CUSCINETTO A UNA CORONA DI RULLI CONICI	TAPERED ROLLER BEARING	1	
6	X20.464.000	PARAOLIO Ø 35x72 IN GOMMA	DUST SHIELDER	1	
7	X04.680.102	SEMIASSE PER EPA	AXLE SHAFT	1	
8	XDI.020.5593F	DADO UNI 5594 - M20x1,5-6S	NUT UNI 5594 - M20x1,5-6S	1	
9	X20.259.000	COPIGLIA Ø 4 L=45 PER MOZZI	SPLIT PIN	1	
10	X04.681.000	COLONNETTA PER SEMIASSE M16x1,5	STUD M16x1,5	5	
11	X04.597.002	COPERCHIETTO DI CHIUSURA	COVER	1	
12	X04.682.000	DADO PER COLONNETTA M 16x1.5	SPECIAL NUT	5	

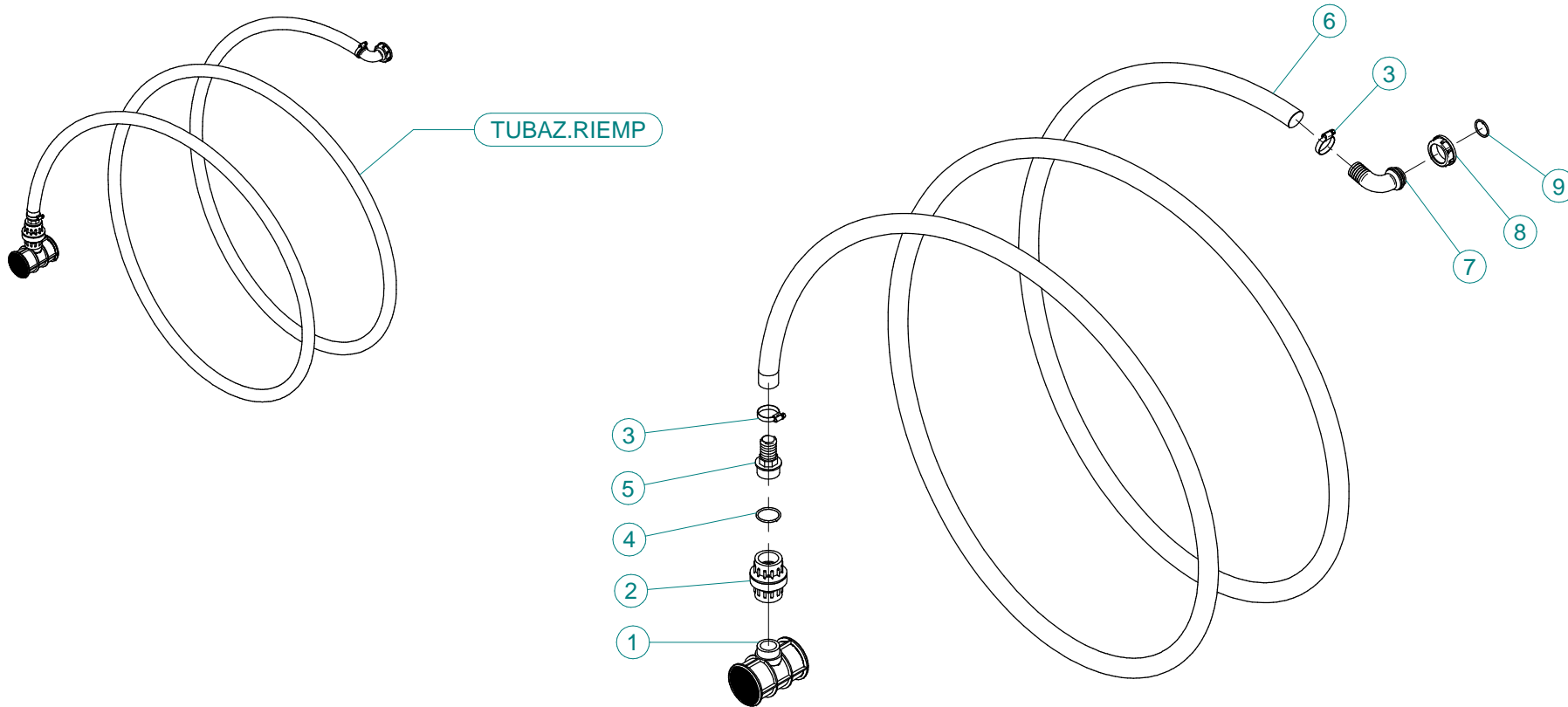

N°	Doc. Number	Titolo	Title	Q.tà	Note
1	X00.611.000	FILTRO A T PER TUBAZIONE RIEMPIMENTO	T FILTER	1	
2	X00.300.000	VALVOLA DI FONDO F-F 1" 1/4	FOOT VALVE F-F 1" 1/4	1	
3	XF0.025.040I	FASCETTA A VITE 25/40 W4 INOX	STAINLESS STEEL CLIP	2	
4	XOR.000.144	OR Ø39,69x3,53	O-RING Ø39,69x3,53	1	
5	X00.423.000	RACCORDO DIRITTO PG 30 FIL.1" 1/4 GAS	MALE CONNECTOR RH 30 1" 1/4 GAS	1	
6	X02.238.450	TUBO SPIRALATO D.30 L=4500	SPIRAL HOSE D.30 L=4500	1	
7	X00.481.000	RACCORDO CURVO P.G. D.30	D.30 HOSETAIL	1	
8	X02.165.000	GIRELLO A FILETTO RAPIDO	RAPID THREAD FLY NUT	1	
9	XOR.000.508	OR D.30 x 3	30 x 3 O-RING GASKET	1	