

Sez. 23 (a)

Timone Sterzante
Steering Drawbar

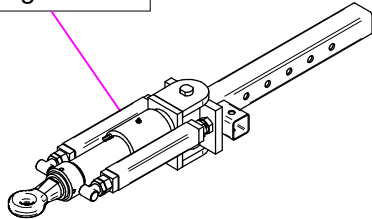

Sez. 23 (a)

Timone Sterzante a 3 punti
Steering Drawbar 3 points

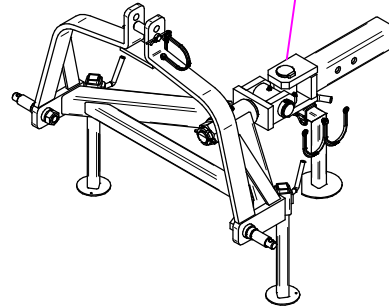

Sez.22 (a)

Tubazione Riempimento
Filling pipe

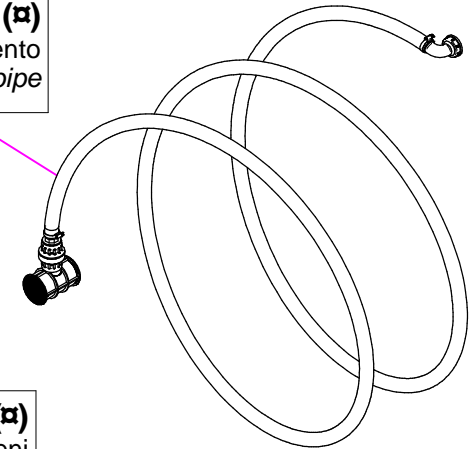

Sez. 23 (a)

Timone Sterzante a 2 punti
Steering Drawbar 2 points

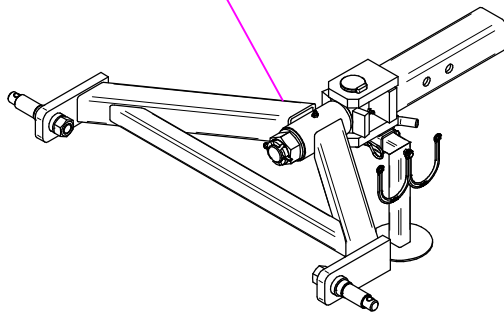

Sez.06E (a)

Elettrovalvola Regolazione Pressione
Solenoid Valves Regulation Pressure

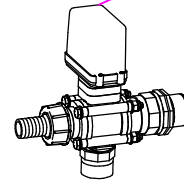

Sez.15A (a)

Freni
Brakes

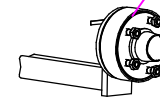

Sez.02E (a)

Kit Lava barattoli
Container Washing
Device Kit

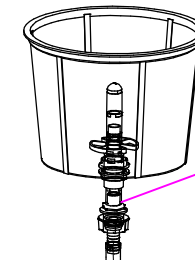

Sez.14 (a)

Ruote in Tandem
Tandem Wheels

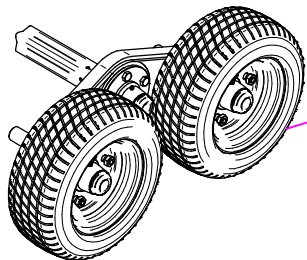

Sez. 01 (a)

Pedana di salita removibile
Footboard

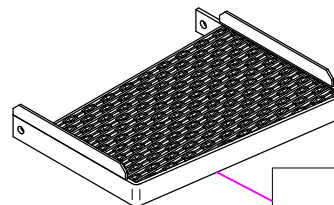

Sez. 26 (a)

Kit Luci
Kit lights

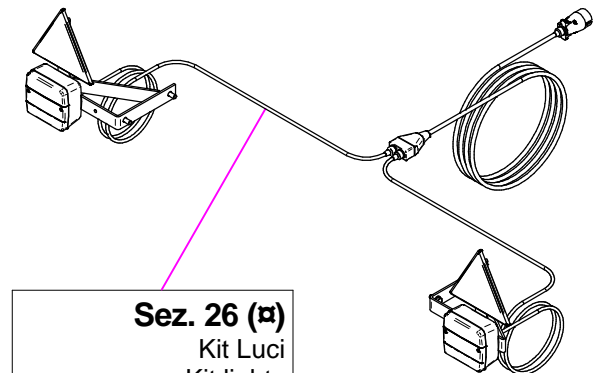

(a) A richiesta / Optional Devices

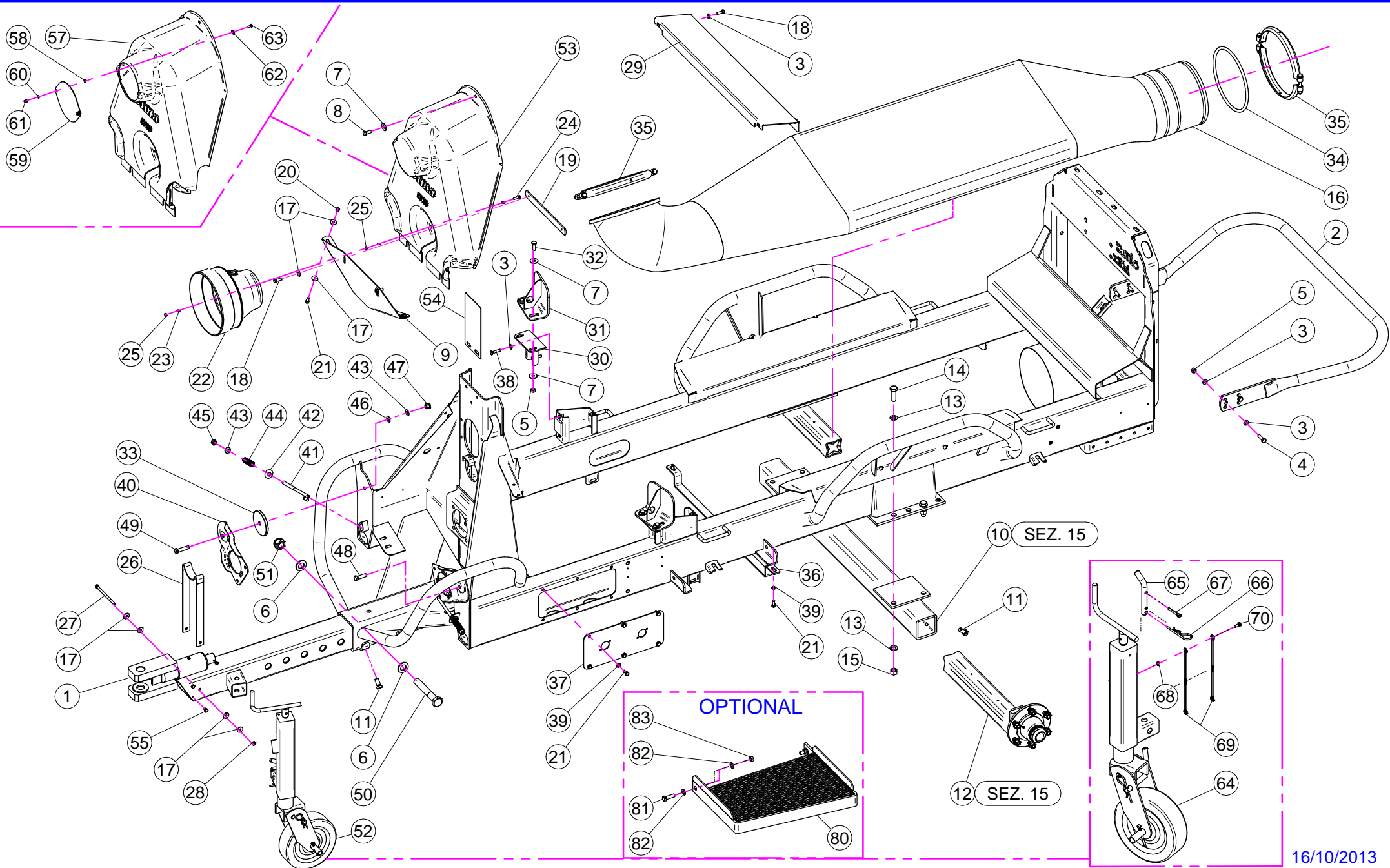

N°	Doc. Number	Titolo	Title	Q.tà	Note
1	X05.862.103	TIMONE TIPO " USA "		1	
2	X40.146.100	CERCHIO DI PROTEZIONE	BUMPER	1	
3	XRP.010.000	RONDELLA PIANA D.10	WASHER D.10	14	
4	XTE.010.035T	VITE TE 10 x 35	SCREW TE 10 x 35	4	
5	XD0.10.5587G	DADO M10	NUT M10	8	
6	XRP.024.000	RONDELLA PIANA D.24	WASHER D.24	2	
7	XRP.010.030	RONDELLA PIANA D.10 x 30 mm	WASHER D.10 x 30 mm	9	
8	XTE.010.025T	VITE TE 10x25T	SCREW TE 10x25T	1	
9	X20.531.000	LAMIERA FISSAGGIO CARTER	CARTER FIXING PLATE	1	
10	X50.035.000	ASSALE	AXLE	1	
11	XTE.014.030T	VITE TE M14x30	SCREW TE M14x30	6	
12	X05.903.100	ASSIEME MOZZO 6 COLONNETTE	HUB	2	
13	XRP.016.000	RONDELLA PIANA D.16	WASHER D.16	8	
14	XTE.016.050T	VITE M16x50	SCREW TE M16x50	4	
15	XD0.16.5587G	DADO M16	NUT M16	4	
16	X05.997.100	TUNNEL PASSAGGIO ARIA BLITZ	AIR WAY TUNNEL BLITZ	1	
17	XRP.008.024	RONDELLA PIANA LARGA D.8X24	WASHER D.8X24	10	
18	XTE.008.025T	VITE TE M8 x 25	SCREW TE M8 x 25	4	
19	X20.532.000	PIATTO BLOCCAGGIO CARTER	FRONT HOUSING BLOCKING PLATE	1	
20	XD0.08.5588G	DADO M8	NUT M8	2	
21	XTE.008.020T	VITE TE 8x20	SCREW TE 8x20	10	
22	X02.441.000	CONTROCUFFIA D.240 PER CARDANO	SHAFT CONE D.240	1	
23	XRD.006.000	RONDELLA DENTELLATA D.6	TAB WASHER D.6	9	
24	XTE.006.025T	VITE TE M6X25	SCREW TE M6X25	3	
25	XD0.06.5588G	DADO M6	NUT M6	6	
26	X20.409.000	SUPPORTO PER CARDANO	SHAFT SUPPORT	1	
27	XTE.008.130	VITE TE M8 x 130	SCREW M8 x 130	1	
28	XDA.008.0AG	DADO AUTOBLOCCANTE M8	SELF LOCKING NUT M8	1	
29	X40.302.201	LAMIERA D'APPOGGIO SERBATOIO	PLATE TANK SUPPORT	1	
30	X50.280.000	STAFFA FISSAGGIO SERBATOIO	BRACKET	2	
31	X20.616.001	STAFFA FERMA SERBATOIO	BRACKET	2	
32	XTE.010.030T	VITE TE M10 x 30	SCREW TE M10 x 30	4	
33	X20.533.100	RONDELLA SPECIALE Ø 100 SP 10 mm	SPECIAL WASHER Ø 100 SP 10 mm	1	
34	X50.007.000	GUARNIZIONE PER TUNNEL BLITZ 55T	GASKET	1	
35	X05.813.010	COLLARE D.275	CLAMP D.275	2	
36	X50.329.000	STAFFA PASSATUBO	BRACKET	1	
37	X50.034.002	CARTER PROTETTIVO VALVOLA 3 VIE	PROTECTION CARTER 3 WAY- VALV	1	
38	XTE.008.035T	VITE TE M8x35	SCREW TE M8x35	4	
39	XRP.008.000	RONDELLA PIANA D.8	WASHER D.8	8	
40	X02.978.000SX	SUPPORTO POMPA TIPO NUOVO	BRACKET	2	
41	X21.005.000	TENDICINGHIA M12 PER POMPA	BELT STRETCHER FOR PUMP	2	
42	X21.113.000	RONDELLA BOMBATA D. 12x36	WASHER D. 12x36	2	
43	XRP.012.000	RONDELLA PIANA D. 12	WASHER D. 12	4	
44	X02.964.000	MOLLA PER POMPA CD 32	CD 32 PUMP SPRING	2	
45	XDOT.12.5587	DADO OTTONE M12	M12 BRASS NUT	2	

N°	Doc. Number	Titolo	Title	Q.tà	Note
46	XMT.012.000	MOLLA A TAZZA D. 12	WASHER D.12	2	
47	XDA.012.0AG	DADO AUTOBLOCCANTE M12	SELF LOCKING NUT M12	2	
48	XTE.012.040T	VITE TE M12X40 UNI 5739	BOLT TE M12X40	1	
49	XTE.012.050T	VITE TE M12x50T	SCREW M12X50T	1	
50	XTE.024.150	VITE TE M24 x 150	SCREW TE M24 x 150	1	
51	XDA.024.0AG	DADO AUTOBLOCCANTE M24	SELF LOCKING M24	1	
52	X05.727.400C	RUOTA D'APPOGGIO ESTRAIBILE	EXTRACTABLE WHEEL	1	
53	X05.723.160	CARTER ANTERIORE PER 2 POMPE	FRONT HOUSING FOR 2 PUMPS	1	
54	X50.355.000	SUPPORTO ADESIVO PRODOTTO	PRODUCT NOTE SUPPORT	1	
55	XTE.008.016T	VITE TE M8x16	SCREW TE M8x16	2	

N°	Doc. Number	Titolo	Title	Q.tà	Note
57	X05.723.060	CARTER ANTERIORE PER 2 POMPE	FRONT HOUSING FOR 2 PUMPS	1	
58	XD0.06.5589G	DADO M6 BASSO	NUT M6	2	
59	X40.333.000	COPERCHIO DISINNESTO	FAN CLUTCH LID	1	
60	XRP.006.000	RONDELLA PIANA D. 6	WASHER D.6	2	
61	XDC.06.5721I	DADO DIN 1587 6x1-6-10	NUT DIN 1587 6x1-6-10	2	
62	XRD.006.000	RONDELLA DENTELLATA D.6	TAB WASHER D.6	2	
63	XTE.006.016T	VITE TE M6X16	SCREW TE M6X16	2	

N°	Doc. Number	Titolo	Title	Q.tà	Note
64	X05.727.400	CORPO RUOTA D'APPOGGIO	SUPPORT WHEEL	1	
65	X20.505.000	SPINOTTO PIEDE D' APPOGGIO	PIN JACK STAND	1	
66	X00.100.004	COPIGLIA D.4	SPLIT PIN D.4	1	
67	XCP.006.040I	COPIGLIA D.6 Lg.40	PIN D.6 Lg.40	1	
68	XD0.06.5588G	DADO M6	NUT M6	1	
69	X21.183.000	STRISCIA FERMATAPPI	CAP STOP	2	
70	XTE.006.016T	VITE TE M6X16	SCREW TE M6X16	1	

OPTIONAL

N°	Doc. Number	Titolo	Title	Q.tà	Note
80	X50.079.101	PEDANA	FOOTBOARD	1	
81	XTE.012.040T	VITE TE M12X40 UNI 5739	BOLT TE M12X40	2	
82	XRP.012.000	RONDELLA PIANA D. 12	WASHER D. 12	4	
83	XDO.12.5588G	DADO M12 PG 5588	M12 6S BIG LEAD NUT 5588	2	

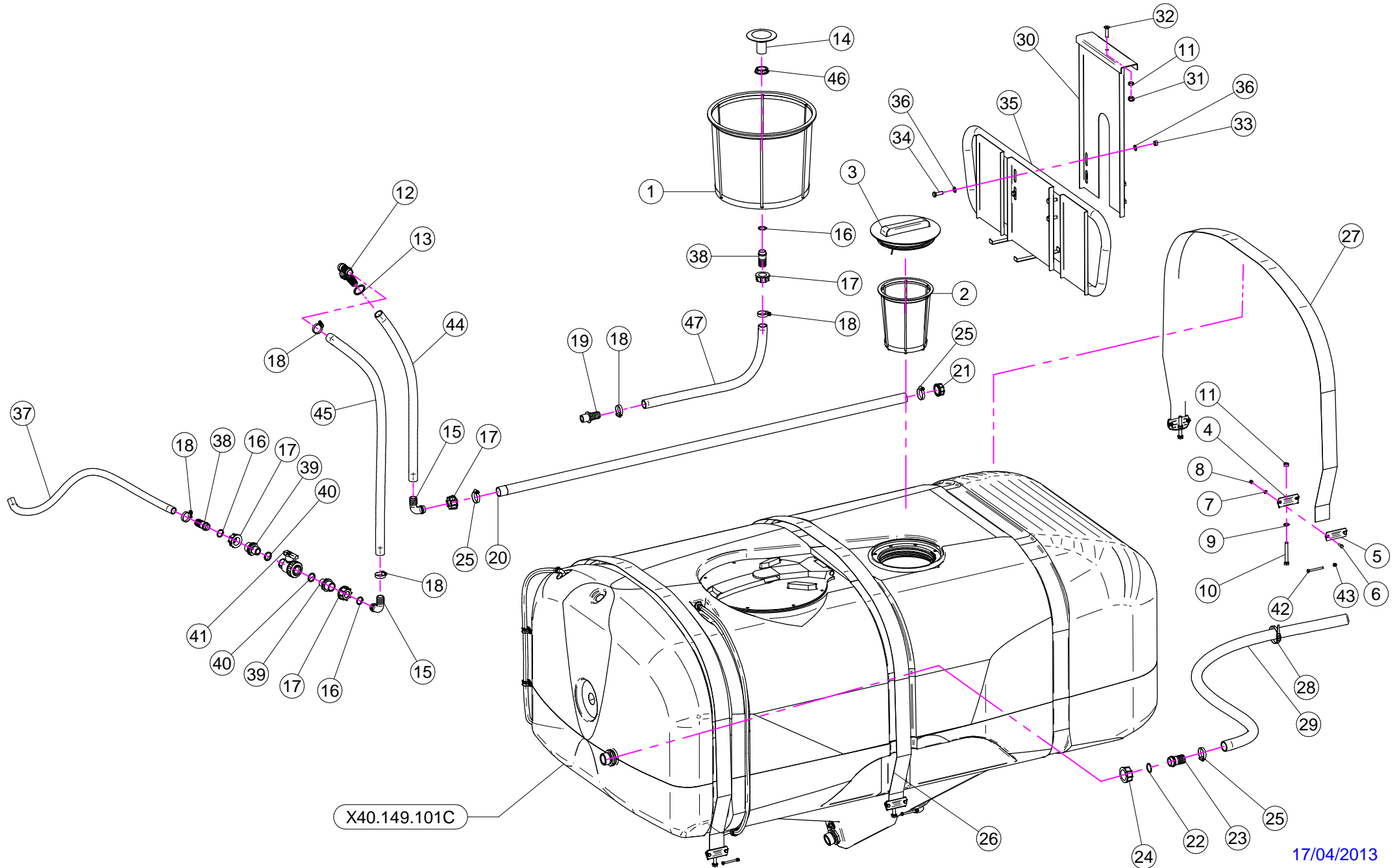

N°	Doc. Number	Titolo	Title	Q.tà	Note
1	X02.404.100	FILTRO A TAZZA 400 x 330	BASKET FILTER 400 x 330	1	
2	X02.298.000	FILTRO A TAZZA D.204	BASKET FILTER D.204	1	
3	X02.476.100	COPERCHIO FILETTATO D.255 CON FILO	THREADED LID D.255 WITH ROPE	1	
4	X20.512.000	STAFFA ANCORAGGIO FASCE	BRACKET	6	
5	X20.513.000	PIASTRINA SERRAGGIO FASCE	SHAPED PLATE	6	
6	XTE.006.020T	VITE TE M6 x 20	SCREW TE M6 x 20	12	
7	XRP.006.000	RONDELLA PIANA D. 6	WASHER D.6	12	
8	XDA.006.0AG	DADO AUTOBLOCCANTE M6	SELF LOCKING NUT M6	12	
9	XRP.010.000	RONDELLA PIANA D.10	WASHER D.10	6	
10	XTE.010.080T	VITE M10x80	M10x80 BOLT	6	
11	XDOT.10.5587	DADO OTTONE M10	M10 BRASS NUT	7	
12	X24.031.000	RACCORDO CURVO P.G. D.26 1" M - GHIERA	PIPE FITTING - BACK NUT	1	
13	X02.066.000	GUARNIZIONE D.33 x 45	GASKET D.33 x 45	1	
14	X00.131.000	PRESA ANTIVORTICE 1"	1" VORTIX DAMPER DRIVE	1	
15	X00.055.037	RACCORDO CURVO P.G. D.25	D.25 HOSETAIL	2	
16	XOR.000.132	OR D.23,81 x 2,62	23,81 x 2,62 O-RING GASKET	3	
17	X00.055.24.2	GIRELLO 1" GAS	1" FLY NUT	4	
18	XF0.023.035I	FASCETTA A VITE 23/35 W4 INOX	STAINLESS STEEL CLIP	5	
19	X20.793.000	RACCORDO DIRITTO P.G. D.25 3/4" GAS M.	HOSETAIL R.H. D.25 3/4" GAS M.	1	
20	X20.608.000	TUBO FORATO 1" L=1700	PERFORATED HOSE 1" L=1700	1	
21	XTF.001.000	TAPPO 1"	PACKING	1	
22	XOR.003.112	OR D.28,24x2,62	O-RING D.28,24x2,62	1	
23	X00.058.028	RACCORDO DIRITTO PG D. 30	STRAIGHT HOSE R.H D.30	1	
24	X00.058.006	GIRELLO 1" 1/4 GAS	1" 1/4 FLY NUT	1	

N°	Doc. Number	Titolo	Title	Q.tà	Note
25	XF0.025.040I	FASCETTA A VITE 25/40 W4 INOX	STAINLESS STEEL CLIP	4	
26	X02.481.250	FASCIA IN NYLON 60 mm L=2500	NYLON BAND 60 mm L=2500	1	
27	X02.481.280	FASCIA IN NYLON 60 mm L=2800	NYLON BAND 60 mm L=2800	2	
28	X02.355.000	FASCETTA D'ASSEMBLAGGIO 292 mm	NYLON ASSEMBLY CLAMP	3	
29	X02.238.170	TUBO SPIRALATO D. 30 L= 1700	HOSE D. 30 L= 1700	1	
30	X20.610.000	STAFFA FISSAGGIO FRANGI ONDA	BRACKET FIXING BREAKWATER	1	
31	XDA.010.0BGI	DADO AUTOBLOCCANTE M10	SELF LOCKING NUT M10	1	
32	XTSCE.010.040TI	VITE A TESTA SVASATA M10 x 40	SCREW M10 x 40	1	
33	XD0.10.5587GI	DADO M10	NUT M10	4	
34	XTE.010.030I	VITE TE M10X30 INOX	INOX M10X30 SCREW	4	
35	X20.609.000	FRANGI ONDA BLITZ 1500-2000	BREAKWATER	1	
36	XRP.010.00I	RONDELLA PIANA D.10 INOX	WASHER D.10 INOX	8	
37	X20.770.100	TUBO SPIRALATO D. 25 L= 1000	HOSE D. 25 L= 1000	1	
38	X00.055.021	RACCORDO DIRITTO PG D.25	STRAIGHT HOSE R.H D.25	2	
39	X02.293.000	RIDUZIONE 1" M - 3/4" M	1" M - 3/4" M REDUCER NIPPLE	2	
40	XOR.000.134	OR D.25,8x3,53	O-RING D.25,8x3,53	2	
41	X02.395.000	RUBINETTO 3/4" GAS F.F. SFERA	VALVE 3/4" GAS F.F. BALL	1	
42	XTE.006.060I	VITE TE M6x60 INOX	INOX M6x60 TE SCREW	6	
43	XDC.06.5721I	DADO DIN 1587 6x1-6-10	NUT DIN 1587 6x1-6-10	6	
44	X20.770.090	TUBO SPIRALATO D. 25 L= 900	HOSE D. 25 L= 900	1	
45	X20.770.100	TUBO SPIRALATO D. 25 L= 1000	HOSE D.25 L=1000	1	
46	X00.542.000	GHIERA 1"	NUT 1"	1	
47	X20.809.200	TUBO D.25 CON RAMINO L=2000	HOSE D.25 L=2000	1	

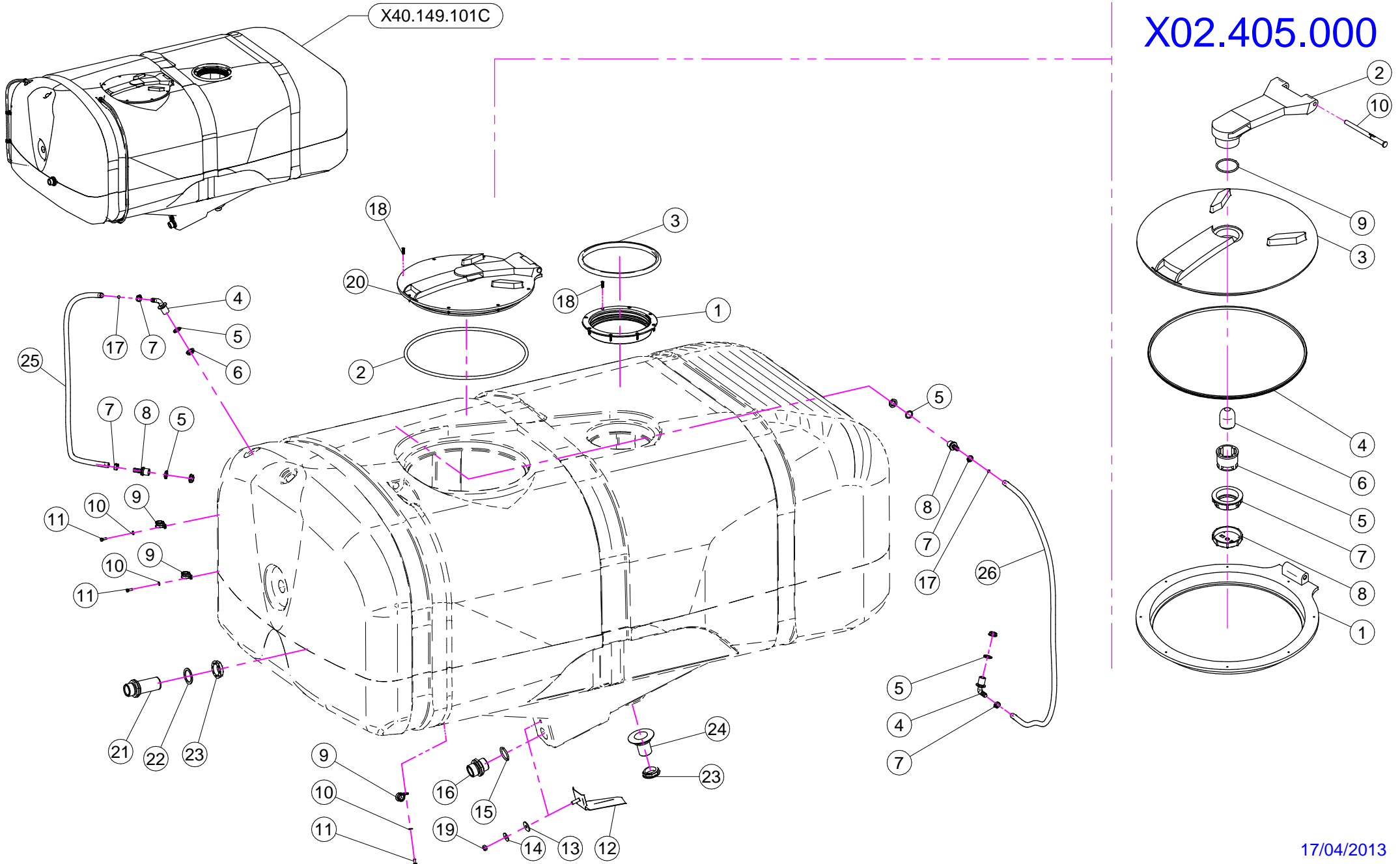

N°	Doc. Number	Titolo	Title	Q.tà	Note
1	X02.477.000	ANELLO FILETTATO D.255	THREATED RING D.255	1	
2	X02.405.000.L	GUARNIZIONE	GASKET	1	
3	X02.477.000.A	GUARNIZIONE PER ANELLO FILETTATO D.255	THREATED RING GASKET D.255	1	
4	X02.457.000	PORTAGOMMA D.13 A 90° M. 1/2"	HOSETAIL D.13 90° M. 1/2"	2	
5	XOR.004.081	OR D.20,22 x 3,53	20,22 x 3,53 O-RING GASKET	4	
6	X02.458.000	GHIERA 1/2"	LOCK RING 1/2"	4	
7	XFC.016,5.018	FASCETTA COBRA 16,5 - 18	KOBRA CLAMP 16,5 - 18	4	
8	X02.482.000	RACCORDO DRITTO P.G.D.13 M. 1/2"	HOSETAIL MALE THREADED 1/2"	2	
9	XFG.018.000	FASCETTA GOMMATA PER TUBI D.18	STICKER	3	
10	XRP.006.000	RONDELLA PIANA D. 6	WASHER D.6	3	
11	XTE.006.016T	VITE TE M6X16	SCREW TE M6X16	3	
12	X20.498.002	ANTIVORTICE IN ACCIAIO INOX	STAINLESS STEEL ANTI-VORTEX	1	
13	X20.436.000	GUARNIZIONE SPECIALE PER ANTIVORTICE	SPECIAL GARNISHING FOR ANTIWHIRL	1	
14	XRP.010.030	RONDELLA PIANA D.10 x 30 mm	WASHER D.10 x 30 mm	1	
15	XOR.006.162	OR D.40,65 x 5,34	O-RING GASKET 40,65 x 5,34	1	
16	X00.345.010	NIPPLO 1" 1/4 + 1" 1/4 GAS	NIPPLE 1" 1/4 + 1" 1/4 GAS	1	
17	X02.478.000	SFERA ROSSA D.8,5 PER LIVELLO	RED FLOATING BALL D.8,5	2	
18	XTAS.04,2.025I	VITE AUTOFILETTANTE 4,2 x 25	SELFTHREADED SCREW 4,2 x 25	16	
19	XDOT.10.5587	DADO OTTONE M10	M10 BRASS NUT	1	
20	X02.405.000	COPERCHIO RIBALTABILE	HINGED TANK LID	1	
21	X00.345.000	NIPPLO 1" 1/4 + 1" 1/4 GAS	NIPPLE 1" 1/4 + 1" 1/4 GAS	1	
22	X02.033.000	GUARNIZIONE PER BOCCHETTONE ASPIRAZIONE	GASKET	1	
23	X00.543.000	GHIERA 1" 1/4 GAS	NUT 1" 1/4 GAS	2	
24	X00.130.000	PRESA ANTIVORTICE 1"1/4 GAS	1"1/4 VORTIX DAMPER DRIVE	1	
25	X02.378.090	TUBETTO VITREO D.16 L=900	HOSE D.16 L=900	1	
26	X02.378.180	TUBETTO VITREO D.16 L=1800	HOSE D.16 L=1800	1	

X02.405.000

N°	Doc. Number	Titolo	Title	Q.tà	Note
1	X02.405.000.B	ANELLO BASE	BASE RING	1	
2	X02.405.001	BRACCIO	ARM	1	
3	X02.405.000.A	DISCO DI CHIUSURA	GRIPPING PLATE	1	
4	X02.405.002	GUARNIZIONE SAGOMATA	SHAPED GASKET	1	
5	X20.787.000.G	CORPO VALVOLA DI SFIATO	BREATHER VALVE	1	
6	X20.787.000.F	SFERA GALLEGGIANTE	FLOATING BALL	1	
7	X20.787.000.H	GHIERA	RING NUT	1	
8	X20.787.000.I	TAPPO PER VALVOLA DI SFIATO	CAP FOR BREATHER VALVE	1	
9	XOR.000.512	OR D.51 x 3,5	51 x 3,5 O-RING GASKET	1	
10	X20.787.000.D	PERNO	PIN	1	

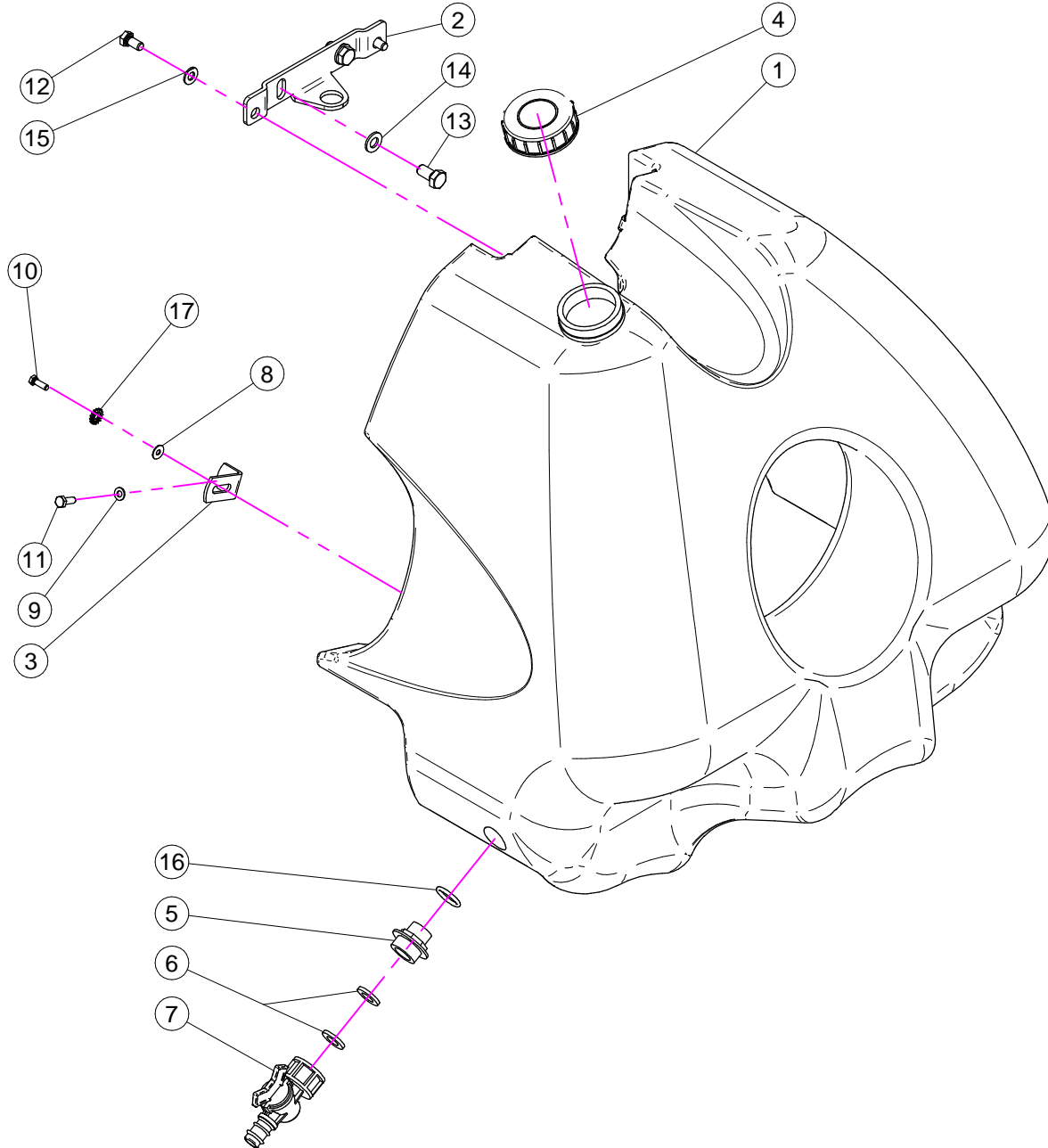
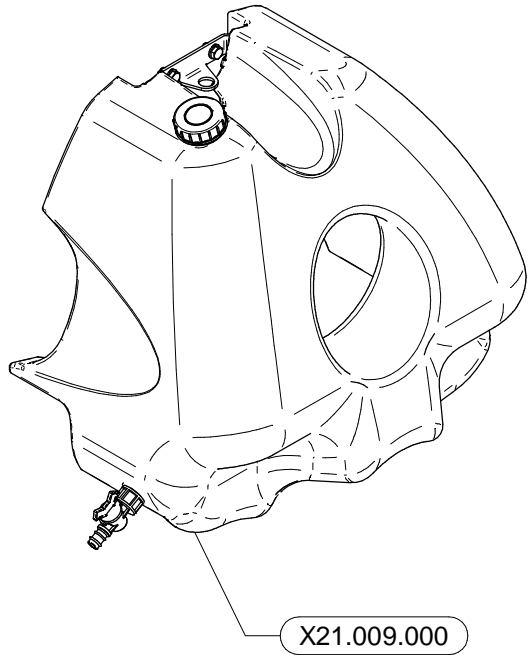

N°	Doc. Number	Titolo	Title	Q.tà	Note
1	X40.322.000	SERBATOIO LAVAMANI 30 Lt.	HAND-WASHING TANK 30 Lt.	1	
2	X40.323.000	STAFFA FISSAGGIO SERBATOIO LAVAMANI	FIXING BRACKET	1	
3	X40.324.100	PIASTRA SERBATOIO LAVAMANI SERIE 50	BRACKET	2	
4	X02.460.000	COPERCHIO FILETTATO FEMMINA	FEMALE THREADED TANK LID	1	
5	X00.055.044	NIPPLO 1/2" GAS 3/4" GAS	NIPPLE 1/2" - 3/4" GAS	1	
6	X02.030.010	GUARNIZIONE TAPPO DISTRIBUTORE	GASKET	2	
7	X02.497.000	RUBINETTO FEMMINA 3/4"	3/4" FEMALE VALVE	1	
8	XRP.005.015I	RONDELLA PIANA D. 5x15	WASHER D. 5x15	2	
9	XRP.006.000	RONDELLA PIANA D. 6	WASHER D.6	2	
10	XTE.005.016I	VITE TE M5X16	SCREW TE M5X16	2	
11	XTE.006.016T	VITE TE M6X16	SCREW TE M6X16	2	
12	XTE.008.016T	VITE TE M8x16	SCREW TE M8x16	2	
13	XTE.010.020T	VITE TE M10 x 20	SCREW TE M10 x 20	2	
14	XRP.010.000	RONDELLA PIANA D.10	WASHER D.10	2	
15	XRP.008.000	RONDELLA PIANA D.8	WASHER D.8	2	
16	XOR.004.081	OR D.20,22 x 3,53	20,22 x 3,53 O-RING GASKET	1	
17	XRD.006.000	RONDELLA DENTELLATA D.6	TAB WASHER D.6	2	

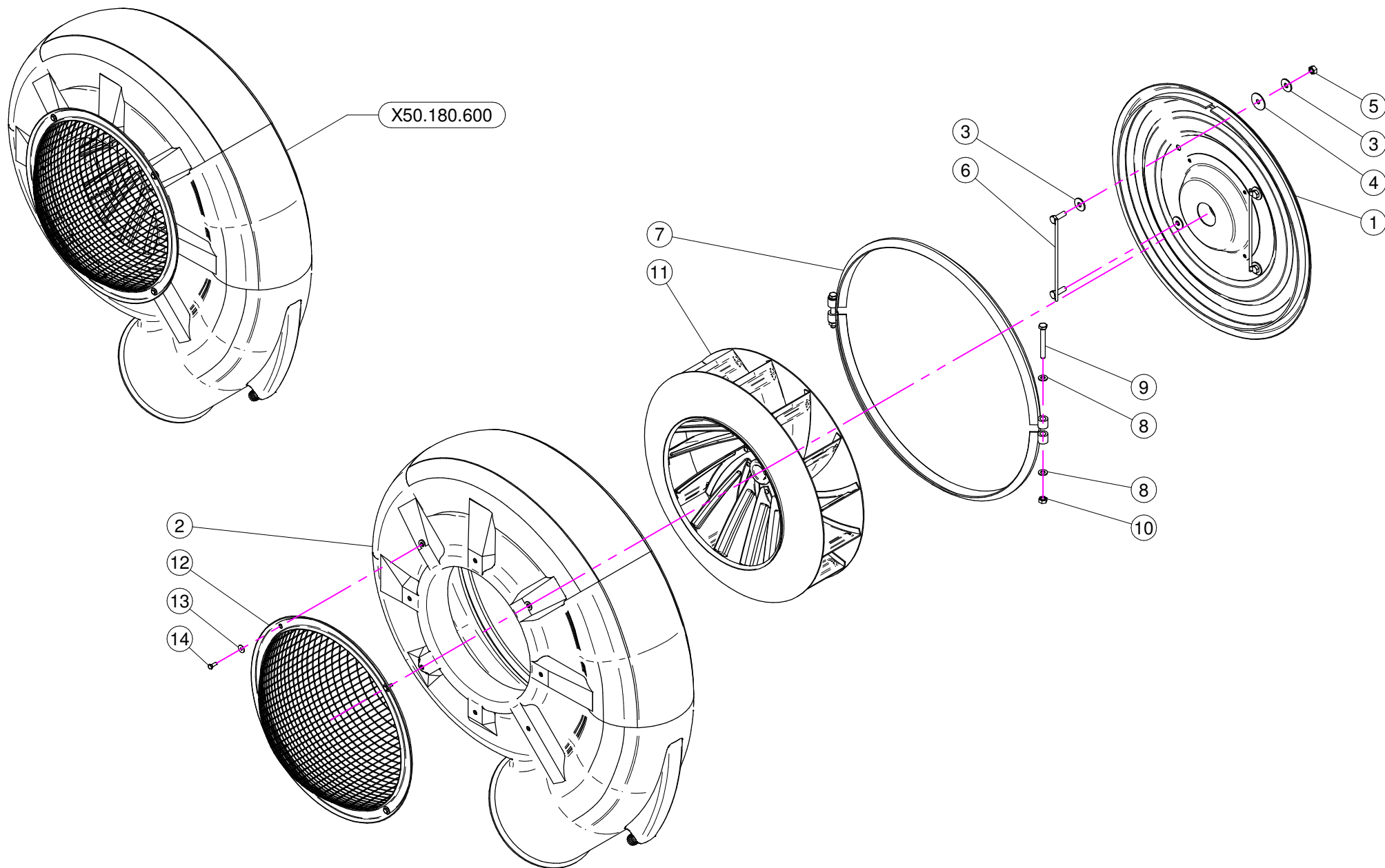

N°	Doc. Number	Titolo	Title	Q.tà	Note
1	X50.172.000	COPERCHIO VENTILATORE PER 55	FAN 55 COVER	1	
2	X50.011.600	CARTER VENTOLA 550	FAN 550 HAUSING	1	
3	XRP.010.030	RONDELLA PIANA D.10 x 30 mm	WASHER D.10 x 30 mm	8	
4	XRP.010.040	RONDELLA PIANA D.10 X 40	WASHER D.10 X 40	4	
5	XD0.10.5587G	DADO M10	NUT M10	4	
6	X20.088.000	CAVALLOTTO FISSAGGIO COPERCHIO POSTERIORE	BACK COVER BRACKET	2	
7	X50.004.000.Z	COLLARE D. 610 PER CHIOCCIOLA 55	D. 610 CLAMP FOR FEMALE SCREW	1	
8	XRP.010.000	RONDELLA PIANA D.10	WASHER D.10	4	
9	XTE.010.080T	VITE M10x80	M10x80 BOLT	2	
10	XDOT.10.5587	DADO OTTONE M10	M10 BRASS NUT	2	
11	X50.012.000	VENTOLA 550	550 FAN	1	
12	X05.654.100	RETE BOMBATA PROTEZIONE VENTILATORE	FAN CONVEX NET PROTECTION	1	
13	XRP.006.018	RONDELLA PIANA D. 6x18	WASHER D.6x18	4	
14	XTE.006.016T	VITE TE M6X16	SCREW TE M6X16	4	

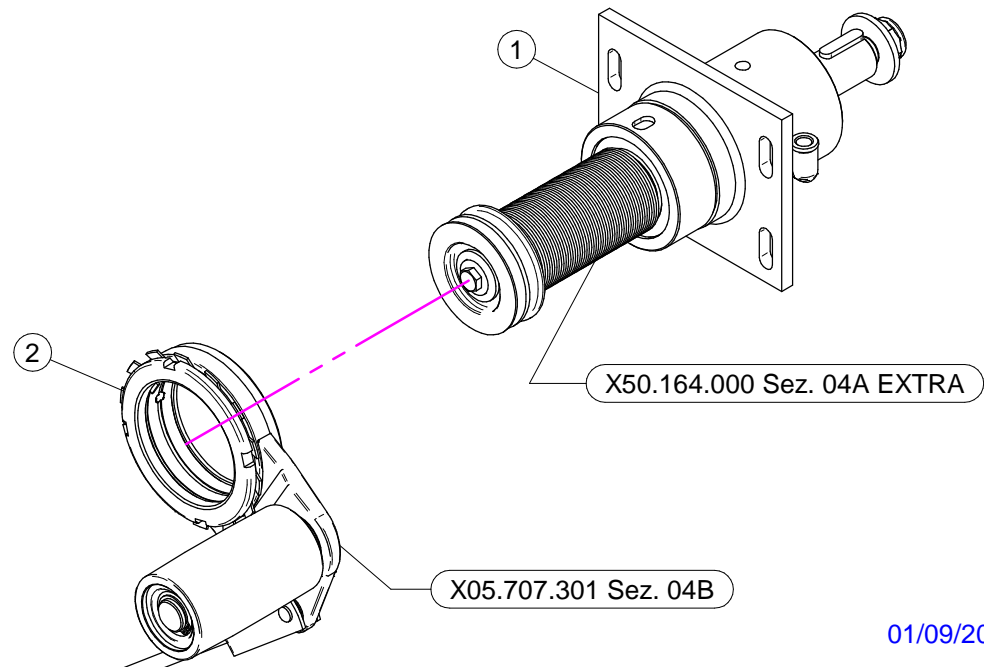
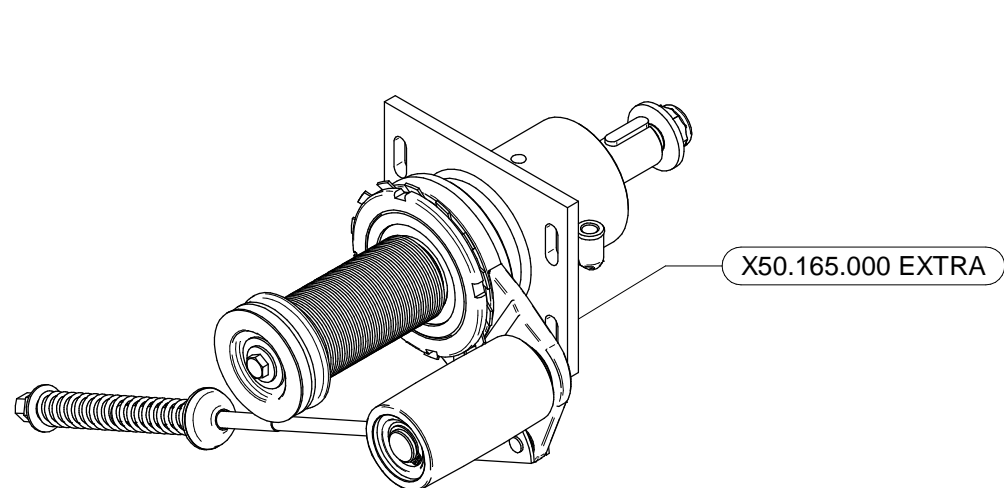
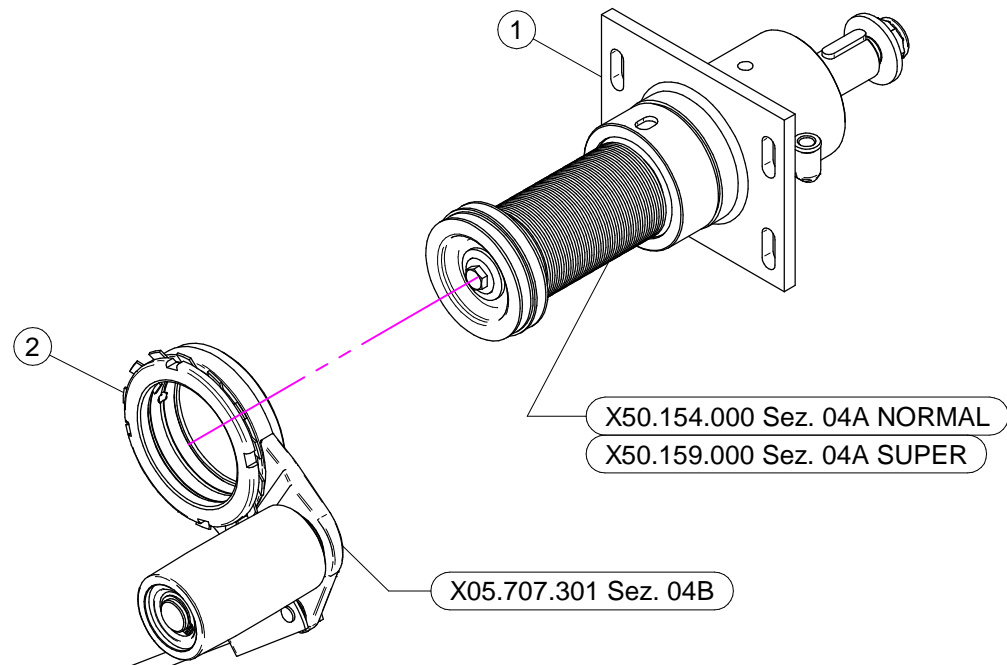
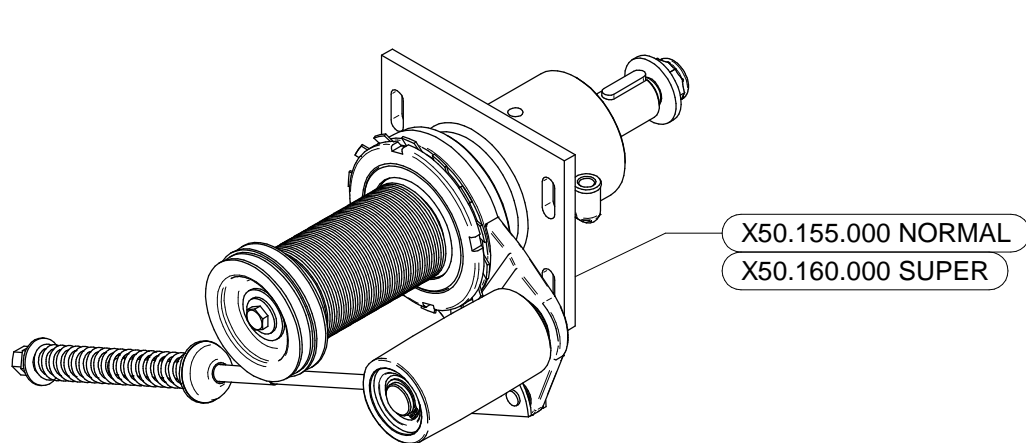

X50.155.000 NORMAL

N°	Doc. Number	Titolo	Title	Q.tà	Note
1	X50.154.000	SUPPORTO OLIO 50 -PULEGGIA D.75 SENZA DISINNESTO	FAN SUPPORT WITH SHAFT - PUL D.75 NO DISENGANGEMENT	1	
2	X05.707.301	TENDICINGHIA AUTOMATICO COMPLETO	AUTOMATIC BELT STRETCHER	1	

X50.160.000 SUPER

N°	Doc. Number	Titolo	Title	Q.tà	Note
1	X50.159.000	SUPPORTO OLIO 50 -PULEGGIA D.70 SENZA DISINNESTO	FAN SUPPORT WITH SHAFT - PUL D.70 NO DISENGANGEMENT	1	
2	X05.707.301	TENDICINGHIA AUTOMATICO COMPLETO	AUTOMATIC BELT STRETCHER	1	

X50.165.000 EXTRA

N°	Doc. Number	Titolo	Title	Q.tà	Note
1	X50.164.000	SUPPORTO OLIO 50 -PULEGGIA D.66 SENZA DISINNESTO	FAN SUPPORT WITH SHAFT - PUL D.66 NO DISENGANGEMENT	1	
2	X05.707.301	TENDICINGHIA AUTOMATICO COMPLETO	AUTOMATIC BELT STRETCHER	1	

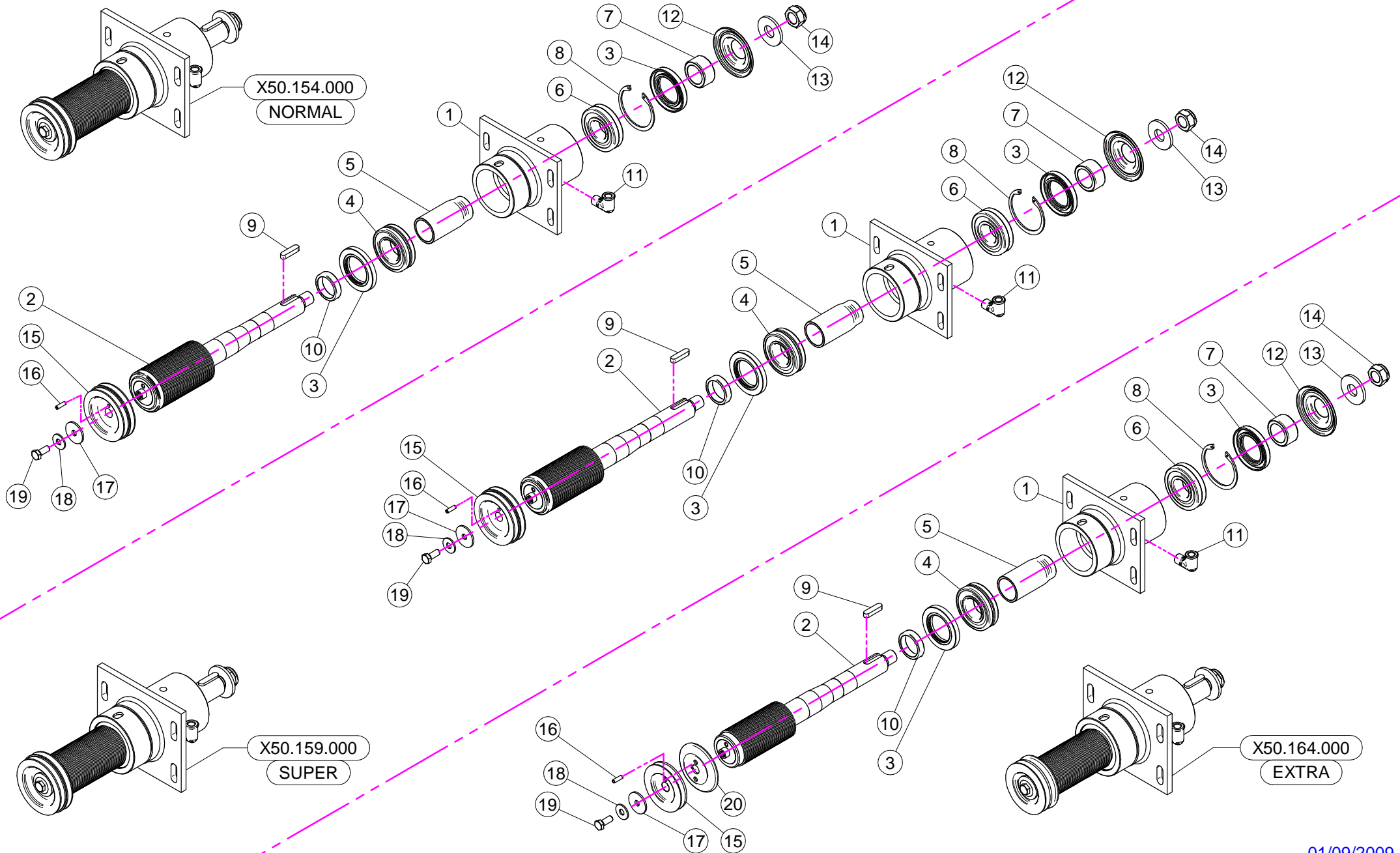

X50.154.000 NORMAL

N°	Doc. Number	Titolo	Title	Q.tà	Note
1	X50.110.000	SUPPORTO VENTILATORE NUDO	NUDE FAN SUPPORT	1	
2	X50.119.075	ALBERO CON PULEGGIA D. 75	SHAFT WITH PULLEY D.75	1	
3	XBASL.50.80.10	ANELLO DI TENUTA IN VITON (50-80-10)	VITON LIP SEALS -IEL (50-80-10)	2	
4	XK0.022.208	CUSCINETTO RULLI OBLIQUI 22-208	ROLLER BEARING 22-208	1	
5	X50.112.000	DISTANZIALE SUPP. VENTILATORE "OLIO"	SPACER	1	
6	XK0.021.307	CUSCINETTO RULLI OBLIQUI 21-307	ROLLER BEARING 21-307	1	
7	X50.113.000	DISTANZIALE TENUTA LATO VENTOLA	SPACER	1	
8	XI0.080.000	ANELLO ELASTICO INTERNO D.80	INTERNAL D.80 CIRCLIP	1	
9	XL.10.08.40	CHIAVETTA 10x8x40	FEATHER KEY 10x8x40	1	
10	X50.114.000	DISTANZIALE PER TENUTA LATO PULEGGIA	SPACER	1	
11	X20.789.000	GOMITO 90° TUBO DI CARICO OLIO	MALE/FEMALE 90° ELBOW	1	
12	X50.115.000	COPERCHIETTO LATO VENTOLA	DUST COVER	1	
13	X20.820.000	RONDELLA BLOCCAGGIO VENTOLA	WASHER	1	
14	XDA.022.0BF	DADO ESAGONALE M22 AUTOBLOCCANTE	SELF-LOCKING NUT M22 x 1,5	1	
15	X05.896.000	PULEGGIA COMANDO POMPA D.99,5/D.95,5 (2x3V)	PULLEY FOR PUMP D.99,5/D.95,5 (2x3V)	1	
16	XSE.006.020	SPINA ELASTICA D.6x20	SPRING PIN D.6x20	1	
17	XRP.010.040	RONDELLA PIANA D.10 X 40	WASHER D.10 X 40	1	
18	XRP.010.028	RONDELLA PIANA D.10 x 28 mm	WASHER D.10 x 28 mm	1	
19	XTE.010.025FT	VITE TE M10x25	BOLT TE M10x25	1	

X50.159.000 SUPER

N°	Doc. Number	Titolo	Title	Q.tà	Note
1	X50.110.000	SUPPORTO VENTILATORE NUDO	NUDE FAN SUPPORT	1	
2	X50.119.070	ALBERO CON PULEGGIA D. 70	SHAFT WITH PULLEY D. 70	1	
3	XBASL.50.80.10	ANELLO DI TENUTA IN VITON (50-80-10)	VITON LIP SEALS -IEL (50-80-10)	2	
4	XK0.022.208	CUSCINETTO RULLI OBLIQUI 22-208	ROLLER BEARING 22-208	1	
5	X50.112.000	DISTANZIALE SUPP. VENTILATORE "OLIO"	SPACER	1	
6	XK0.021.307	CUSCINETTO RULLI OBLIQUI 21-307	ROLLER BEARING 21-307	1	
7	X50.113.000	DISTANZIALE TENUTA LATO VENTOLA	SPACER	1	
8	XI0.080.000	ANELLO ELASTICO INTERNO D.80	INTERNAL D.80 CIRCLIP	1	
9	XL.10.08.40	CHIAVETTA 10x8x40	FEATHER KEY 10x8x40	1	
10	X50.114.000	DISTANZIALE PER TENUTA LATO PULEGGIA	SPACER	1	
11	X20.789.000	GOMITO 90° TUBO DI CARICO OLIO	MALE/FEMALE 90° ELBOW	1	
12	X50.115.000	COPERCHIETTO LATO VENTOLA	DUST COVER	1	
13	X20.820.000	RONDELLA BLOCCAGGIO VENTOLA	WASHER	1	
14	XDA.022.0BF	DADO ESAGONALE M22 AUTOBLOCCANTE	SELF-LOCKING NUT M22 x 1,5	1	
15	X05.896.000	PULEGGIA COMANDO POMPA D.99,5/D.95,5 (2x3V)	PULLEY FOR PUMP D.99,5/D.95,5 (2x3V)	1	
16	XSE.006.020	SPINA ELASTICA D.6x20	SPRING PIN D.6x20	1	
17	XRP.010.040	RONDELLA PIANA D.10 X 40	WASHER D.10 X 40	1	
18	XRP.010.028	RONDELLA PIANA D.10 x 28 mm	WASHER D.10 x 28 mm	1	
19	XTE.010.025FT	VITE TE M10x25	BOLT TE M10x25	1	

X50.164.000 EXTRA

N°	Doc. Number	Titolo	Title	Q.tà	Note
1	X50.110.000	SUPPORTO VENTILATORE NUDO	NUDE FAN SUPPORT	1	
2	X50.119.066	ALBERO CON PULEGGIA D. 66	SHAFT WITH PULLEY D.66	1	
3	XBASL.50.80.10	ANELLO DI TENUTA IN VITON (50-80-10)	VITON LIP SEALS -IEL (50-80-10)	2	
4	XK0.022.208	CUSCINETTO RULLI OBLIQUI 22-208	ROLLER BEARING 22-208	1	
5	X50.112.000	DISTANZIALE SUPP. VENTILATORE "OLIO"	SPACER	1	
6	XK0.021.307	CUSCINETTO RULLI OBLIQUI 21-307	ROLLER BEARING 21-307	1	
7	X50.113.000	DISTANZIALE TENUTA LATO VENTOLA	SPACER	1	
8	XI0.080.000	ANELLO ELASTICO INTERNO D.80	INTERNAL D.80 CIRCLIP	1	
9	XL.10.08.40	CHIAVETTA 10x8x40	FEATHER KEY 10x8x40	1	
10	X50.114.000	DISTANZIALE PER TENUTA LATO PULEGGIA	SPACER	1	
11	X20.789.000	GOMITO 90° TUBO DI CARICO OLIO	MALE/FEMALE 90° ELBOW	1	
12	X50.115.000	COPERCHIETTO LATO VENTOLA	DUST COVER	1	
13	X20.820.000	RONDELLA BLOCCAGGIO VENTOLA	WASHER	1	
14	XDA.022.0BF	DADO ESAGONALE M22 AUTOBLOCCANTE	SELF-LOCKING NUT M22 x 1,5	1	
15	X05.816.000	PULEGGIA COMANDO POMPA D.88 (1 x 3V)	PULLEY FOR PUMP D.88 (1x3V)	1	
16	XSE.006.020	SPINA ELASTICA D.6x20	SPRING PIN D.6x20	1	
17	XRP.010.040	RONDELLA PIANA D.10 X 40	WASHER D.10 X 40	1	
18	XRP.010.028	RONDELLA PIANA D.10 x 28 mm	WASHER D.10 x 28 mm	1	
19	XTE.010.025FT	VITE TE M10x25	BOLT TE M10x25	1	
20	X02.723.000A	SEMPULEGGIA D.88	SEMPULLEY D.88	1	

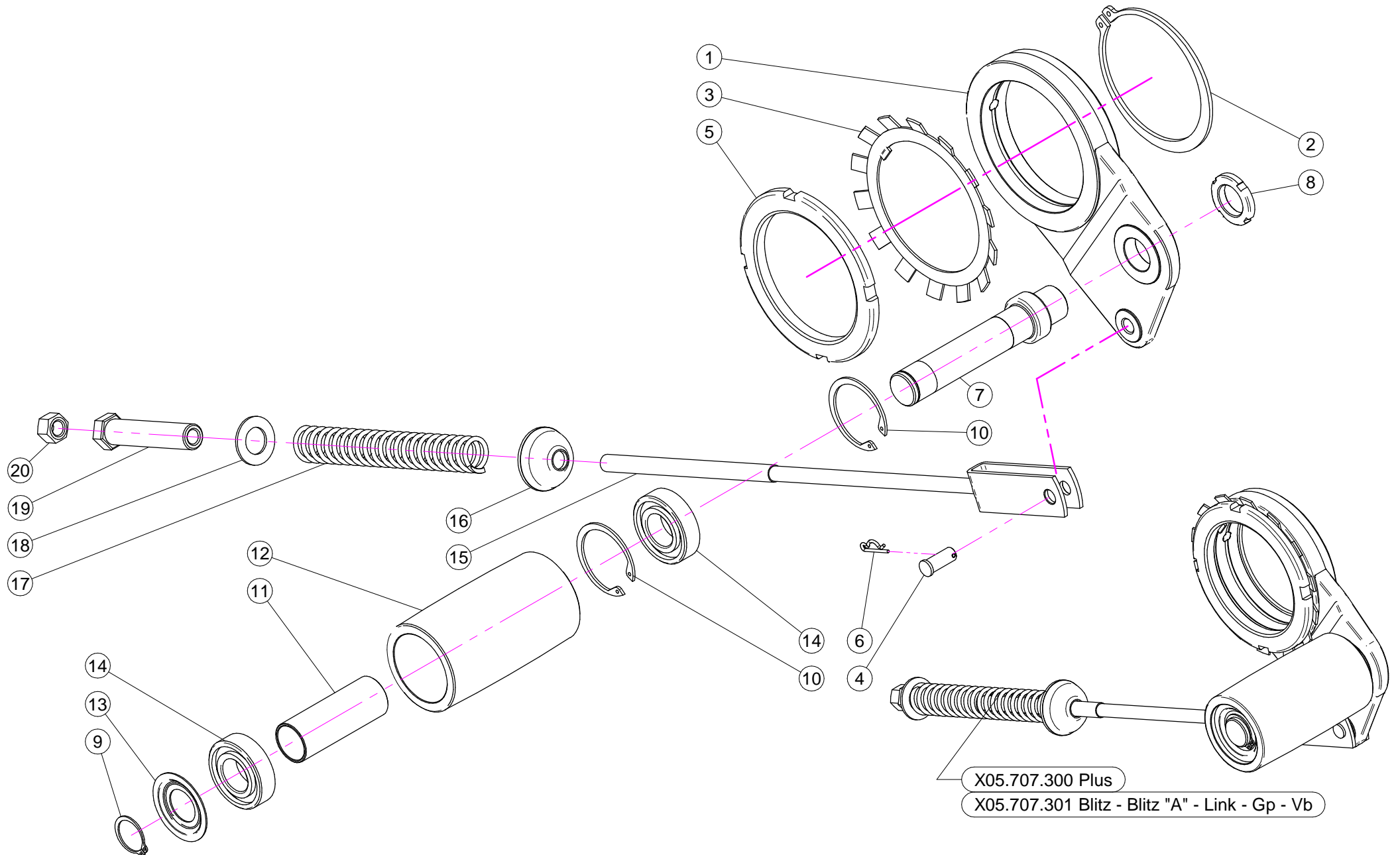

X05.707.300 PLUS

N°	Doc. Number	Titolo	Title	Q.tà	Note
1	X05.696.000	SUPPORTO PER TENDICINGHIA AUTOMATICO	IDLER SUPPORT	1	
2	XE0.100.000	ANELLO ELASTICO ESTERNO D.100	EXTERNAL D. 100 CIRCLIP	1	
3	XMB.020.000	ROSETTA DI SICUREZZA MB 20	TOOTH LOCK WASHER	1	
4	X04.593.000	PERNO FORCELLA TENDICINGHIA	PIN	1	
5	X05.704.000	GHIERA DI REGISTRO M100 X 2	REGISTER NUT	1	
6	X00.100.002	COPIGLIA	CLIP	1	
7	X05.697.000	PERNO TENDICINGHIA AUTOMATICO	PIVOT	1	
8	XKM.005.000	GHIERA KM5	NUT KM5	1	
9	XE0.025.000	ANELLO ELASTICO ESTERNO D. 25	EXTERNAL D. 25 CIRCLIP	1	
10	XI0.052.000	ANELLO ELASTICO INTERNO D. 52	INTERNAL D. 52 CIRCLIP	2	
11	X05.631.101	DISTANZIALE TENDICINGHIA AUTOMATICO	SPACER	1	
12	X05.630.000	RULLO PER TENDICINGHIA AUTOMATICO	ROLLER	1	
13	X04.585.000	COPERCHIO PARAPOLVERE TENDICINGHIA	ANTI - DUST COVER	1	
14	XK6.205.2RS	CUSCINETTO 6205-2RS	ROLLER BEARING 6205-2RS	2	
15	X05.726.000	FORCELLA TENSIONE TENDICINGHIA	BELT STRETCHER FORK	1	*
16	X20.260.000	RONDELLA BOMBATA D.12 PER TENDICINGHIA	SPECIAL WASHER D.12	1	
17	X05.647.100	MOLLA TENDICINGHIA AUTOMATICO	SPRING	1	
18	XRP.019.000	RONDELLA PIANA D.19 6592	WASHER D.19	1	
19	X04.583.000	VITE SPECIALE MOLLA TENDICINGHIA	SPECIAL SCREW	1	
20	XD0.12.5587G	DADO M12 PG UNI 5587	M12 NUT	1	

X05.707.301 BLITZ - BLITZ "A" - LINK - GP - VB

N°	Doc. Number	Titolo	Title	Q.tà	Note
1	X05.696.000	SUPPORTO PER TENDICINGHIA AUTOMATICO	IDLER SUPPORT	1	
2	XE0.100.000	ANELLO ELASTICO ESTERNO D.100	EXTERNAL D. 100 CIRCLIP	1	
3	XMB.020.000	ROSETTA DI SICUREZZA MB 20	TOOTH LOCK WASHER	1	
4	X04.593.000	PERNO FORCELLA TENDICINGHIA	PIN	1	
5	X05.704.000	GHIERA DI REGISTRO M100 X 2	REGISTER NUT	1	
6	X00.100.002	COPIGLIA	CLIP	1	
7	X05.697.000	PERNO TENDICINGHIA AUTOMATICO	PIVOT	1	
8	XKM.005.000	GHIERA KM5	NUT KM5	1	
9	XE0.025.000	ANELLO ELASTICO ESTERNO D. 25	EXTERNAL D. 25 CIRCLIP	1	
10	XI0.052.000	ANELLO ELASTICO INTERNO D. 52	INTERNAL D. 52 CIRCLIP	2	
11	X05.631.101	DISTANZIALE TENDICINGHIA AUTOMATICO	SPACER	1	
12	X05.630.000	RULLO PER TENDICINGHIA AUTOMATICO	ROLLER	1	
13	X04.585.000	COPERCHIO PARAPOLVERE TENDICINGHIA	ANTI - DUST COVER	1	
14	XK6.205.2RS	CUSCINETTO 6205-2RS	ROLLER BEARING 6205-2RS	2	
15	X05.653.000	FORCELLA TENSIONE TENDICINGHIA	BELT TRETCHER FORK	1	*
16	X20.260.000	RONDELLA BOMBATA D.12 PER TENDICINGHIA	SPECIAL WASHER D.12	1	
17	X05.647.100	MOLLA TENDICINGHIA AUTOMATICO	SPRING	1	
18	XRP.019.000	RONDELLA PIANA D.19 6592	WASHER D.19	1	
19	X04.583.000	VITE SPECIALE MOLLA TENDICINGHIA	SPECIAL SCREW	1	
20	XD0.12.5587G	DADO M12 PG UNI 5587	M12 NUT	1	

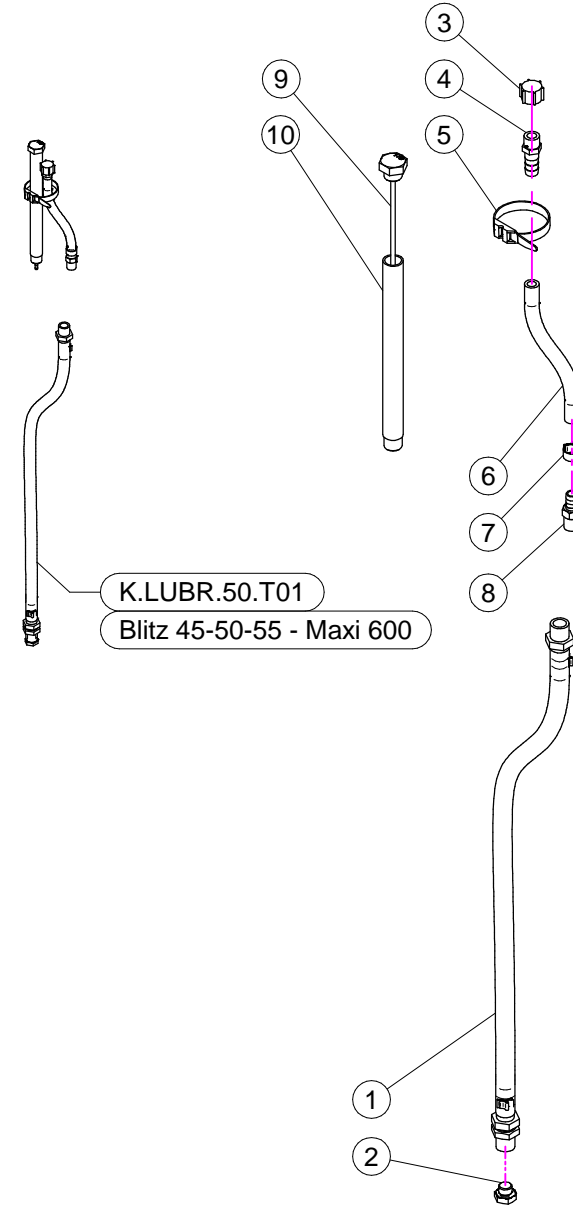
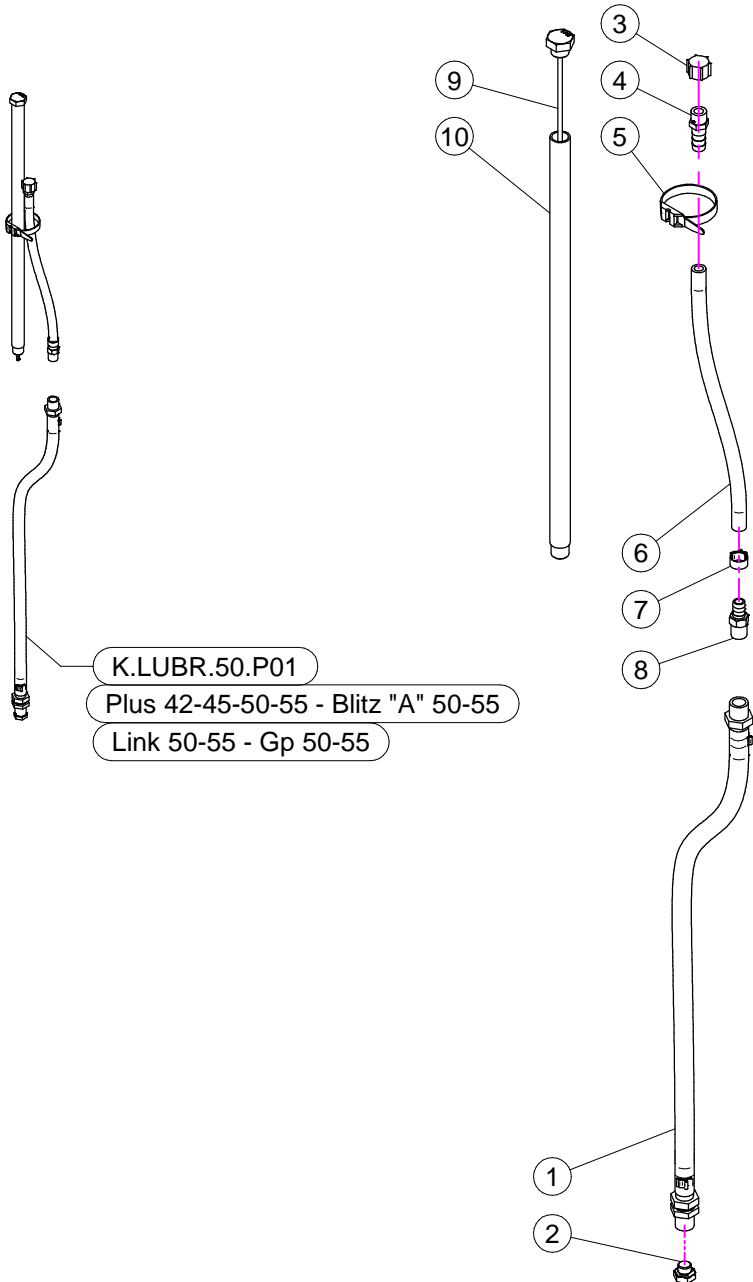

K.LUBR.50.P01 (Plus 42-45-50-55 - Blitz "A" 50-55 - Link 50-55 - Gp 50-55)

N°	Doc. Number	Titolo	Title	Q.tà	Note
1	X20.790.000	TUBO DI SCARICO OLIO 3/8" CIL. - 3/8" CON.	DRAIN PIPE 3/8"	1	
2	X40.266.000	TAPPO SCARICO OLIO M12x1,5	OIL EXHAUSTPLUG	1	
3	X02.013.000	TAPPO CIMA G 1/4" F.	PLUG G 1/4"	1	
4	X00.414.100	PORTAGOMMA D.11 1/4" M. FORATO	STRAIGHT HOSE D.11 1/4" WITH BLEED	1	
5	X02.355.000	FASCETTA D'ASSEMBLAGGIO 235 mm	NYLON ASSEMBLY CLAMP	1	
6	X02.217.025	TUBO D. 8x13 L= 250	HOSE D. 8x13 L= 250	1	
7	XFC.014,5.016	FASCETTA COBRA SLO30716	KOBRA CLAMP	1	
8	X20.792.000	PORTAGOMMA D.11 G 1/4" M. PER SFIATO	STRAIGHT HOSE D.11 G 1/4" FOR BREATHER	1	
9	X50.116.000	TAPPO CON ASTA LIVELLO OLIO L=465	FILLING PLUG WITH DIPSTICK	1	
10	X50.122.000	TUBO DI CARICO OLIO L=451	FILLING PIPE L=451	1	

K.LUBR.50.T01 (Blitz 45-50-55 - Maxi 600)

N°	Doc. Number	Titolo	Title	Q.tà	Note
1	X20.790.000	TUBO DI SCARICO OLIO 3/8" CIL. - 3/8" CON.	DRAIN PIPE 3/8"	1	
2	X40.266.000	TAPPO SCARICO OLIO M12x1,5	OIL EXHAUSTPLUG	1	
3	X02.013.000	TAPPO CIMA G 1/4" F.	PLUG G 1/4"	1	
4	X00.414.100	PORTAGOMMA D.11 1/4" M. FORATO	STRAIGHT HOSE D.11 1/4" WITH BLEED	1	
5	X02.355.000	FASCETTA D'ASSEMBLAGGIO 235 mm	NYLON ASSEMBLY CLAMP	1	
6	X02.217.015	TUBO D. 8x13 L= 150	HOSE D. 8x13 L= 150	1	
7	XFC.014,5.016	FASCETTA COBRA SLO30716	KOBRA CLAMP	1	
8	X20.792.000	PORTAGOMMA D.11 G 1/4" M. PER SFIATO	STRAIGHT HOSE D.11 G 1/4" FOR BREATHER	1	
9	X40.269.000	TAPPO CON ASTA LIVELLO OLIO L=215	FILLING PLUG WITH DIPSTICK L=215	1	
10	X40.272.000	TUBO CARICAMENTO L=201	FILLING PIPE L=201	1	

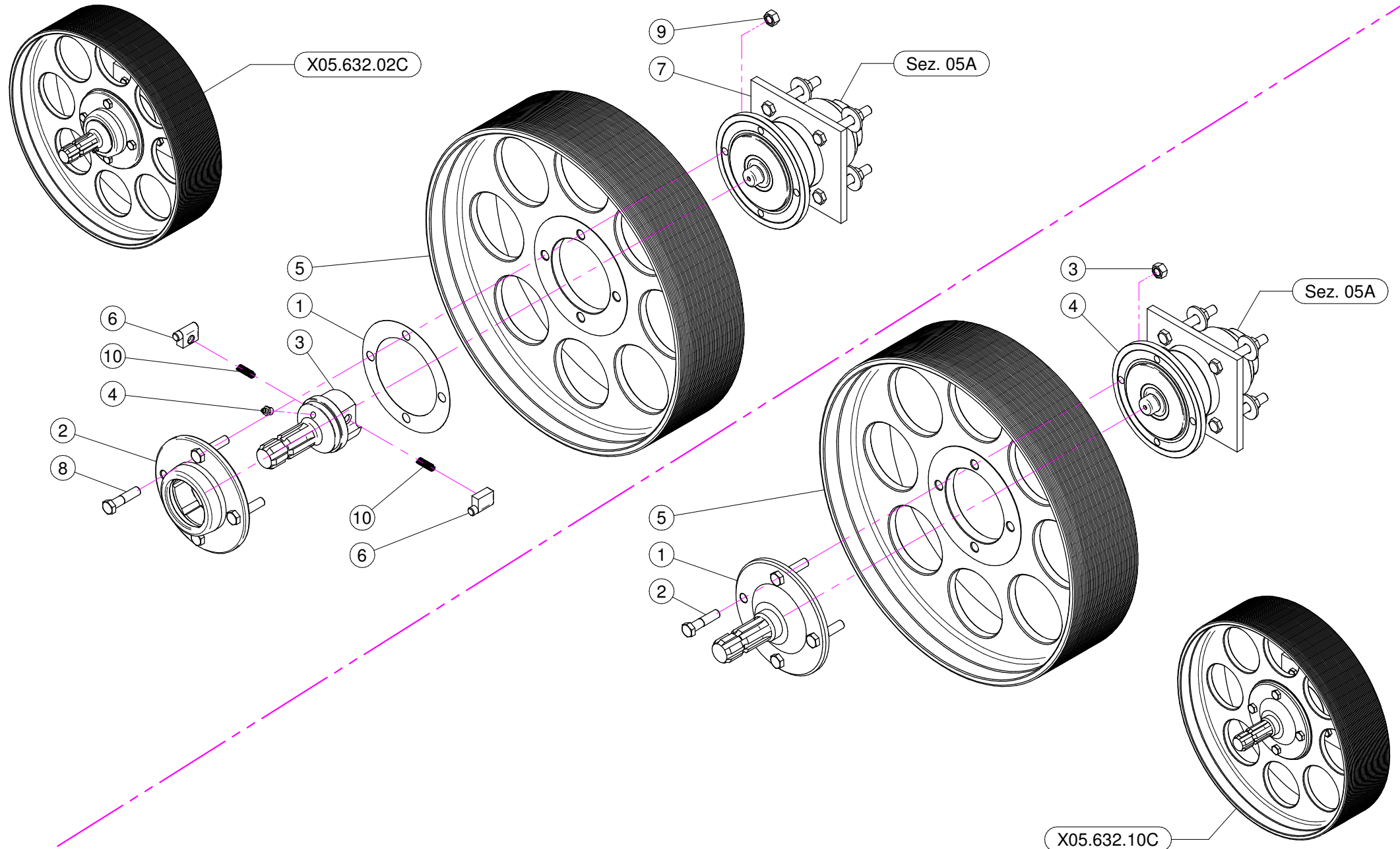

X05.632.02C

N°	Doc. Number	Titolo	Title	Q.tà	Note
1	X04.719.000	GUARNIZIONE RUOTA LIBERA	GASKET	1	
2	X04.066.000	CORPO ESTERNO RUOTA LIBERA	BODY	1	
3	X03.701.000	ROTORE RUOTA LIBERA	ROTOR	1	
4	XID.010.001	INGRASSATORE DIRITTO M10X1	GREASE NIPPLE	1	
5	X00.480.J50	PULEGGIA DIAM. 480 J 50	PULLEY DIAM. 480 J 50	1	
6	X02.502.002	MARTELLETTO RUOTA LIBERA	PIN	2	
7	X05.632.01C	SUPPORTO INFERIORE 50 / 55 D	CLUTCH	1	
8	XTE.012.050F	VITE TE M12X50	BOLT M12X50	4	
9	XDO.12.5587F	DADO M12 PG 5587F	NUT M12 PG 5587F	4	
10	X02.502.001	MOLLA A COMPRESSIONE	SPRING	2	

X05.632.10C

N°	Doc. Number	Titolo	Title	Q.tà	Note
1	X04.707.100	ALBERO SCANALATO PER P.D.P.	SHAFT	1	
2	XTE.012.050F	VITE TE M12X50	BOLT M12X50	4	
3	XDO.12.5587F	DADO M12 PG 5587F	NUT M12 PG 5587F	4	
4	X05.632.01C	SUPPORTO INFERIORE 50 / 55 D	CLUTCH	1	
5	X00.480.J50	PULEGGIA DIAM. 480 J 50	PULLEY DIAM. 480 J 50	1	

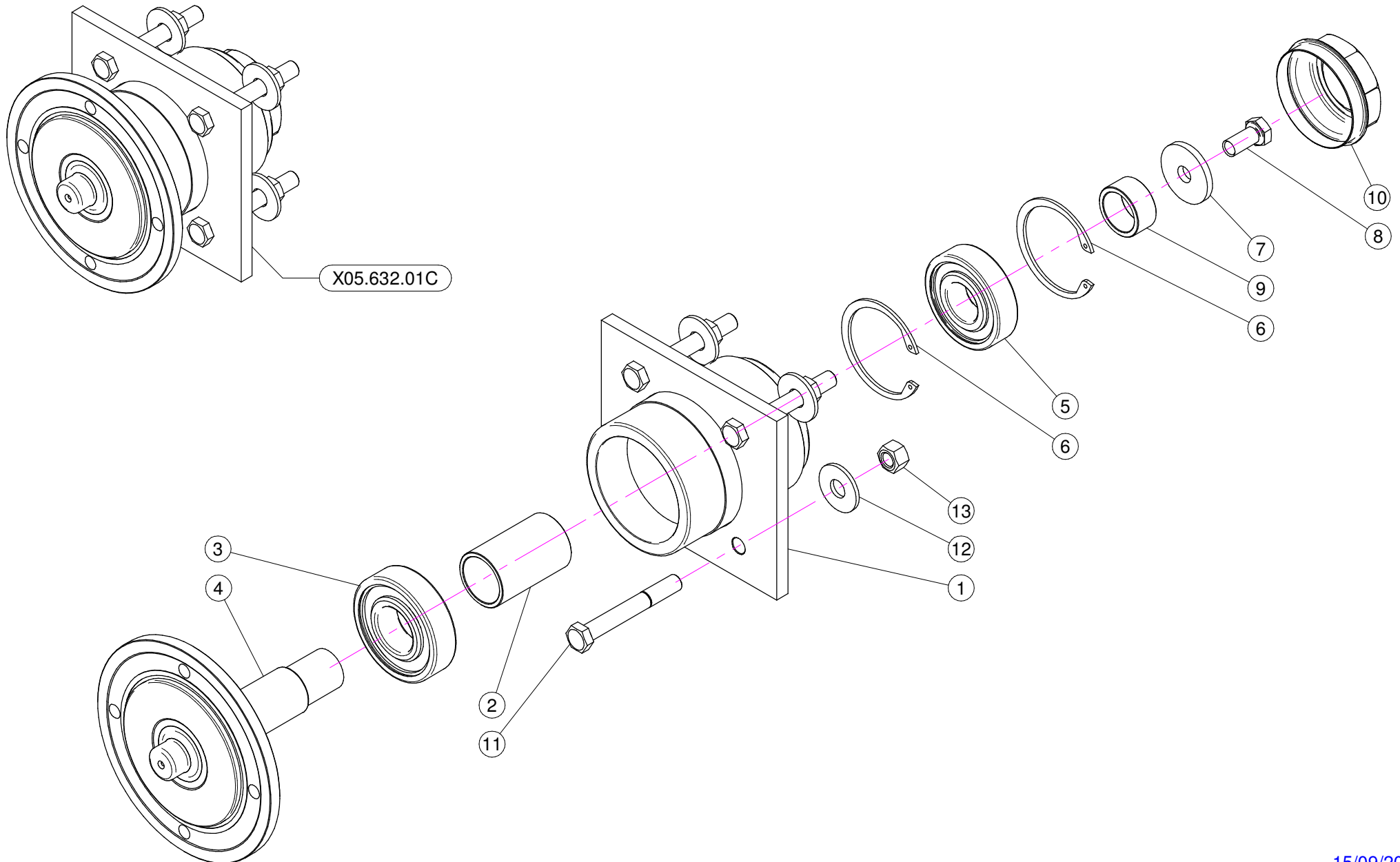

N°	Doc. Number	Titolo	Title	Q.tà	Note
1	X05.632.000	SUPPORTO INFERIORE	LOWER SUPPORT	1	
2	X04.565.000	DISTANZIALE PER ALBERO INFERIORE	LOWER SHAFT SPACING BAR	1	
3	XK6.307.2RS	CUSCINETTO	BEARING	1	
4	X04.589.000	ALBERO INFERIORE	LOWER SHAFT	1	
5	XK6.306.2RS	CUSCINETTO	BEARING	1	
6	XI0.072.000	ANELLO ELASTICO INTERNO D.72	SPACING BAR	2	
7	X20.810.000	RONDELLA SPECIALE PER SUPPORTO INFERIORE	SPECIAL WASHER FOR LOWER SUPPORT	1	
8	XTE.012.025FT	VITE TE 12X25	BOLT TE M12X1.25	1	
9	X04.590.000	DISTANZIALE PER ALBERO INFERIORE	SPACER	1	
10	X04.555.001	COPERCHIETTO DI CHIUSURA	COVER	1	
11	XTE.012.090	VITE TE M12 x 90	SCREW TE M12 x 90	4	
12	XRP.012.036	RONDELLA PIANA D12 X 36	WASHER D12 X 36	4	
13	XD0.12.5587G	DADO M12 PG UNI 5587	M12 NUT	4	

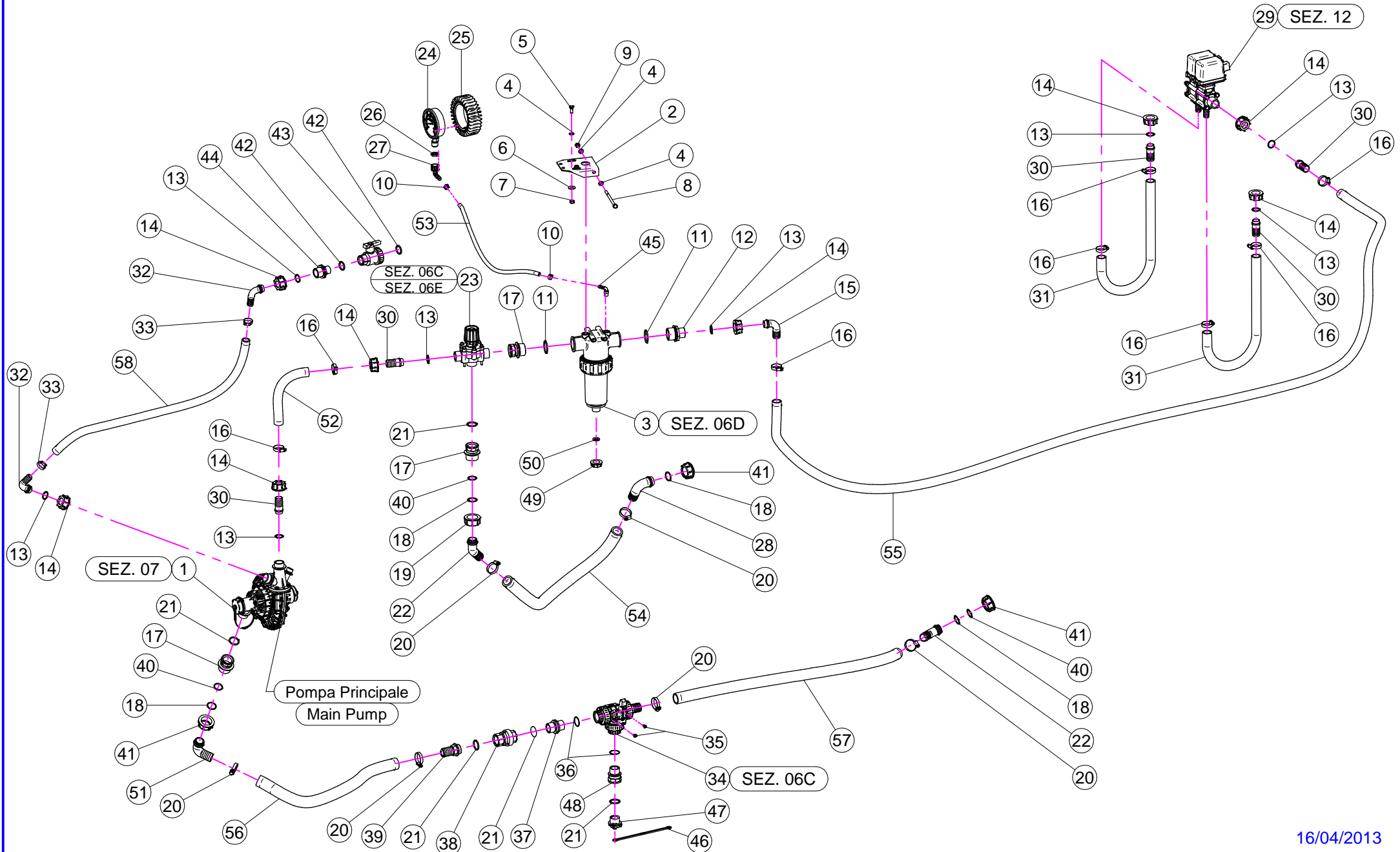

N°	Doc. Number	Titolo	Title	Q.tà	N°	Doc. Number	Titolo	Title	Q.tà
1	X02.157.071	POMPA COMPLETA	PUMP	1	30	X00.055.021	RACCORDO DIRITTO PG D.25	STRAIGHT HOSE R.H D.25	5
2	X20.519.100	STAFFA FISSAGGIO GRUPPO REGOLAZIONE	BRACKET	1	31	X20.770.110	TUBO D.25x32 L=1100	HOSE D.25x32 L=1100	2
3	X02.450.110	FILTRO IN LINEA F. 1" 1/4	LINE FILTER 1" 1/4 FEMALE	1	32	X00.055.038	RACCORDO CURVO A P.G. D.19	CURVED UNION WITH R.H. D.19	2
4	XRP.008.000	RONDELLA PIANA D.8	WASHER D.8	4	33	XFC.027,5.029	FASCETTA COBRA 27,08 - W8	KOBRA CLAMP 27,08 - W8	2
5	XTE.008.025T	VITE TE 8X25	SCREW TE M8X25	2	34	X21.058.300	VALVOLA 3 VIE A SFERA CON 1 PG D.30	THREE WAYS VALVE	1
6	XRP.008.024	RONDELLA PIANA LARGA D.8X24	WASHER D.8X24	2	35	XTA.006.012P	VITI PER MAT. PLASTICI M6 x 12	SCREW M6 x 12	2
7	XD0.08.5588G	DADO M8 6S PG	M8 6S BIG LEAD NUT 5588	2	36	XOR.002.125	OR D.31,47 x 1,78	31,47 x 1,78 O-RING GASKET	2
8	XTE.008.130	VITE TE M8 x 130	SCREW M8 x 130	1	37	X00.055.034	NIPPLO 1" / 1" GAS	NIPPLE 1" / 1" GAS	1
9	XDA.008.0AG	DADO AUTOBLOCCANTE M8	SELF LOCKING NUT M8	1	38	X21.149.000	VALVOLA DI RITEGNO 1" F.-F.	VALVE 1" F.-F.	1
10	XFC.013,5.015	FASCETTA COBRA SLO30710	KOBRA CLAMP	2	39	X00.422.100	RACCORDO DIRITTO PG 30 FIL.1" GAS TORNITO	MALE CONNECTOR RH 30 1" GAS	1
11	XOR.000.144	OR D.39,69x3,53	O-RING D.39,69x3,53	2	40	XOR.003.106	OR D.26.65x2.62	O-RING D.26.65x2.62	3
12	X00.045.012	RIDUZIONE 1" 1/4 M - 1" M	1" 1/4 M - 1" M REDUCER NIPPLE	1	41	X00.493.000	GIRELLO 1" 1/4 GAS	1" 1/4 FLY NUT	3
13	XOR.000.132	OR D.23,81 x 2,62	23,81 x 2,62 O-RING GASKET	8	42	XOR.000.134	OR D.25,8x3,53	O-RING D.25,8x3,53	2
14	X00.055.24.2	GIRELLO 1" GAS	1" FLY NUT	8	43	X02.395.000	RUBINETTO 3/4" GAS F.F. SFERA	VALVE 3/4" GAS F.F. BALL	1
15	X00.055.037	RACCORDO CURVO P.G. D.25	D.25 HOSETAIL	1	44	X02.293.000	RIDUZIONE 1" M - 3/4" M	1" M - 3/4" M REDUCER NIPPLE	1
16	XF0.023.035I	FASCETTA A VITE 23/35 W4 INOX	STAINLESS STEEL CLIP	8	45	X21.084.000	RACCORDO 90° WES 8 / R1/4	HOSETAIL 90° WES 8 / R1/4	1
17	X02.374.000	RIDUZIONE M/F 1"F / 1"1/4M	M. / F. 1"F / 1"1/4M REDUCTION	3	46	X21.183.000	STRISCIA FERMATAPPI	CAP STOP	1
18	XOR.003.112	OR D.28,24x2,62	O-RING D.28,24x2,62	4	47	X21.182.000	TAPPO 1" M	PACKING 1" M	1
19	X00.058.006	GIRELLO 1" 1/4 GAS	1" 1/4 FLY NUT	1	48	X02.384.000	RIDUZIONE 1" M - 1" F	1" M - 1" F REDUCER NIPPLE	1
20	XF0.025.040I	FASCETTA A VITE 25/40 W4 INOX	STAINLESS STEEL CLIP	6	49	X02.182.000	TAPPO 3/4" FEMMINA	FEMALE 3/4" CAP	1
21	XOR.004.118	OR D.29,75 x 3,53	29,75 x 3,53 O-RING GASKET	5	50	X02.030.010	GUARNIZIONE TAPPO DISTRIBUTORE	GASKET	1
22	X02.339.000	RACCORDO CURVO A 45° CON P.G. D.30	45° HOSETAIL	2	51	X00.483.000	RACCORDO CURVO PG 30 1-1/4"	D.30 1-1/4" HOSETAIL	1
23	X02.447.000	VALVOLA A 3 VIE	3 WAY VALVE	1	52	X20.809.030	TUBO CON RAMINO D.25 L=300	HOSE D.25 L=300	1
24	X02.445.000	MANOMETRO D.100 INOX 0-6 BAR	PRESSURE GAUGE Ø100 INOX 0-6 BAR	1	53	X02.217.040	TUBO D. 8x13 L= 400	HOSE D. 8x13 L= 400	1
25	X02.470.000	CUFFIA PER MANOMETRO D.100	PRESSURE GAUGE GUARD	1	54	X20.852.060	TUBO D. 30x41 L= 800	HOSE D. 30x41 L= 800	1
26	X24.072.000	GHIERA IN OTTONE 1/2"	BRASS FLY NUT 1/2"	1	55	X20.770.350	TUBO D. 25x32 L= 3500	HOSE D. 25x32 L= 3500	1
27	X21.012.000	RACCORDO CURVO PG D. 12 G. 1/2"	D. 12 HOSETAIL	1	56	X20.852.080	TUBO CON RAMINO D.30 L=800	HOSE D.30 L=800	1
28	X00.058.004	RACCORDO CURVO P.G. D.30	D.30 HOSETAIL	1	57	X02.238.090	TUBO D. 30x38 L= 900	HOSE D. 30x38 L= 900	1
29	X02.390.09C	ELETTROVALVOLE	ELECTROVALVES	1	58	X02.212.100	TUBO D. 19x28 L= 1000	HOSE D. 19x28 L= 1000	1

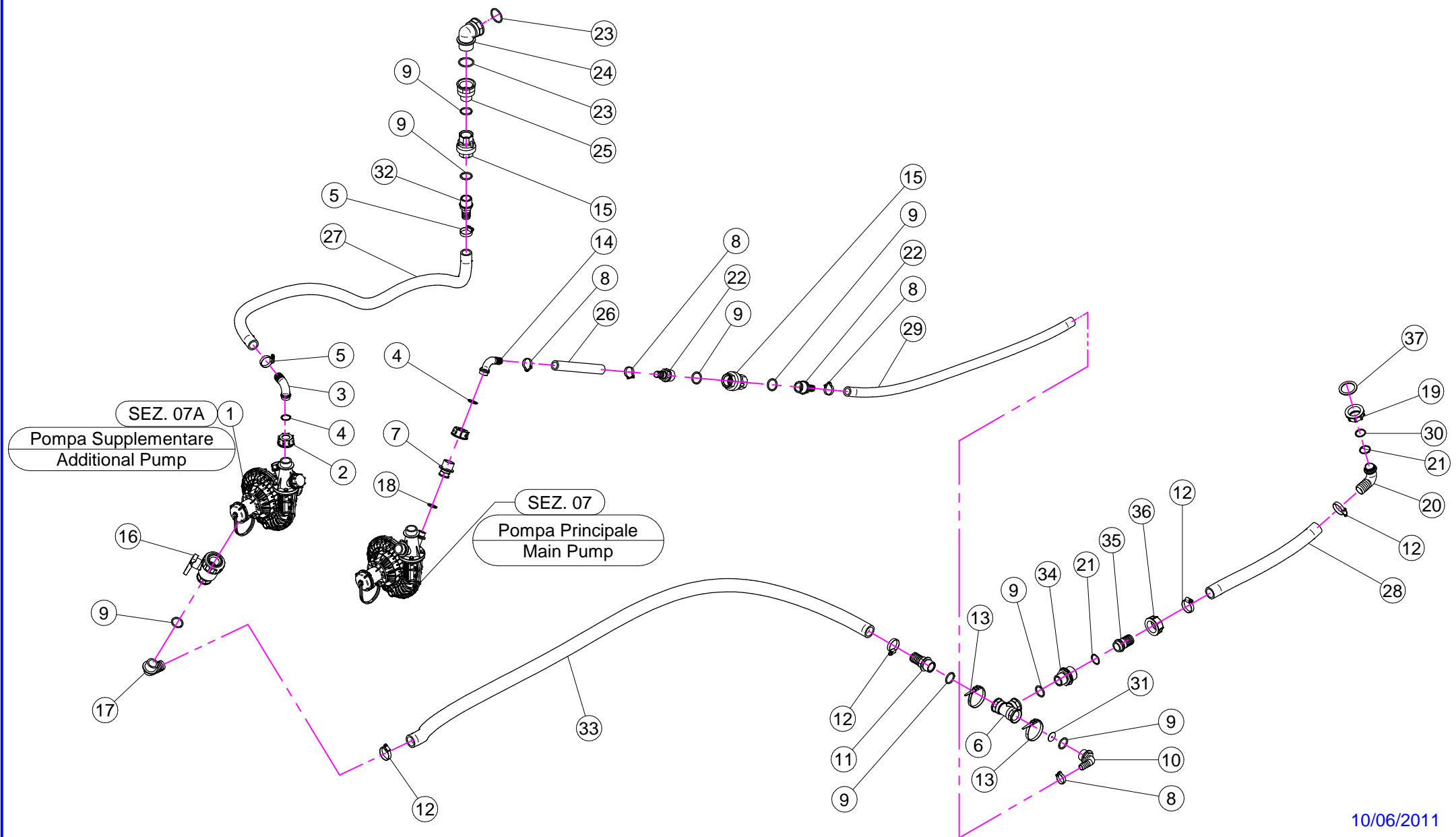

N°	Doc. Number	Titolo	Title	Q.tà	Note
1	X02.157.062	POMPA COMPLETA	PUMP	1	
2	X00.055.24.2	GIRELLO 1" GAS	1" FLY NUT	2	
3	X00.055.037	RACCORDO CURVO P.G. D.25	D.25 HOSETAIL	1	
4	XOR.000.132	OR D.23,81 x 2,62	23,81 x 2,62 O-RING GASKET	2	
5	XF0.023.035I	FASCETTA A VITE 23/35 W4 INOX	STAINLESS STEEL CLIP	2	
6	X02.274.000	RACCORDO FILETTATO A T 1" FEMMINA	FEMALE TESSE 1"	1	
7	X21.186.000	RIDUZIONE 1" M - 1/2" F	REDUCER NIPPLE 1" M - 1/2" F	1	
8	XFC.027,5.029	FASCETTA COBRA 27,08 - W8	KOBRA CLAMP 27,08 - W8	4	
9	XOR.004.118	OR D.29,75 x 3,53	29,75 x 3,53 O-RING GASKET	8	
10	X21.193.000	RACCORDO CURVO 90° 1" P.G.	HOSETAIL 90° 1" R.H.	1	
11	X00.422.000	RACCORDO DIRITTO PG 30 FIL.1" GAS	MALE CONNECTOR RH 30 1" GAS	1	
12	XF0.025.040I	FASCETTA A VITE 25/40 W4 INOX	STAINLESS STEEL CLIP	4	
13	X02.355.000	FASCETTA D'ASSEMBLAGGIO 292 mm	NYLON ASSEMBLY CLAMP	2	
14	X00.055.038	RACCORDO CURVO A P.G. D.19	CURVED UNION WITH R.H. D.19	1	
15	X21.149.000	VALVOLA DI RITEGNO 1" F.-F.	VALVE 1" F.-F.	2	
16	X04.109.000	VALVOLA A SFERA A 2 VIE	TWO WAYS VALVE	1	
17	X00.465.000	RACCORDO CURVO A P.G. D.30 1" GAS	HOSETAIL D.30 1" GAS	1	
18	XOR.004.081	OR D.20,22 x 3,53	20,22 x 3,53 O-RING GASKET	1	
19	X00.493.000	GIRELLO 1" 1/4 GAS	1" 1/4 FLY NUT	1	
20	X00.483.000	RACCORDO CURVO PG 30 1-1/4"	D.30 1-1/4" HOSETAIL	1	
21	XOR.003.112	OR D.28,24x2,62	O-RING D.28,24x2,62	2	
22	X02.402.100	RACCORDO DIRITTO PG D.19 - 1"	STRAIGHT HOSE R. H D.19 - 1"	2	
23	XOR.000.144	OR D.39,69x3,53	O-RING D.39,69x3,53	2	
24	X24.070.000	RACCORDO CURVO M-F 1"1/4	HOSETAIL 1"1/4	1	
25	X02.361.100	RIDUZIONE 1" 1/4 F - 1" M (tagliata)	REDUCER NIPPLE 1" 1/4 F - 1" M (cut)	1	
26	X02.212.017	TUBO D. 19 L= 170	HOSE D. 19 L= 170	1	
27	X20.809.120	TUBO SPIRALATO D. 25 L= 1200	HOSE D. 25 L= 1200	1	
28	X20.852.090	TUBO SPIRALATO D. 30 L= 900	HOSE D. 30 L= 900	1	
29	X02.212.120	TUBO D. 19 L= 1200	HOSE D. 19 L= 1200	1	
30	XOR.003.106	OR D.26.65x2.62	O-RING D.26.65x2.62	1	
31	X40.386.000	RONDELLA CON FORO D.4 x RACCORDO A T 2° POMPA BLITZ E LINK	WASHER WITH HOLE D.4 x TEE-PIECE UNION 2° PUMP BLITZ AND LINK	1	
32	X02.403.000	RACCORDO DIRITTO PG D.25 - 1"	STRAIGHT HOSE R. H D.25 - 1"	1	
33	X20.852.200	TUBO SPIRALATO D. 30 L= 2000	HOSE D. 30 L= 2000	1	
34	X00.045.012	RIDUZIONE 1" 1/4 M - 1" M	1" 1/4 M - 1" M REDUCER NIPPLE	1	
35	X00.058.028	RACCORDO DIRITTO PG D. 30	STRAIGHT HOSE R.H D.30	1	
36	X00.058.006	GIRELLO 1" 1/4 GAS	1" 1/4 FLY NUT	1	
37	X02.033.000	GUARNIZIONE PER BOCCHETTONE ASPIRAZIONE	GASKET	1	

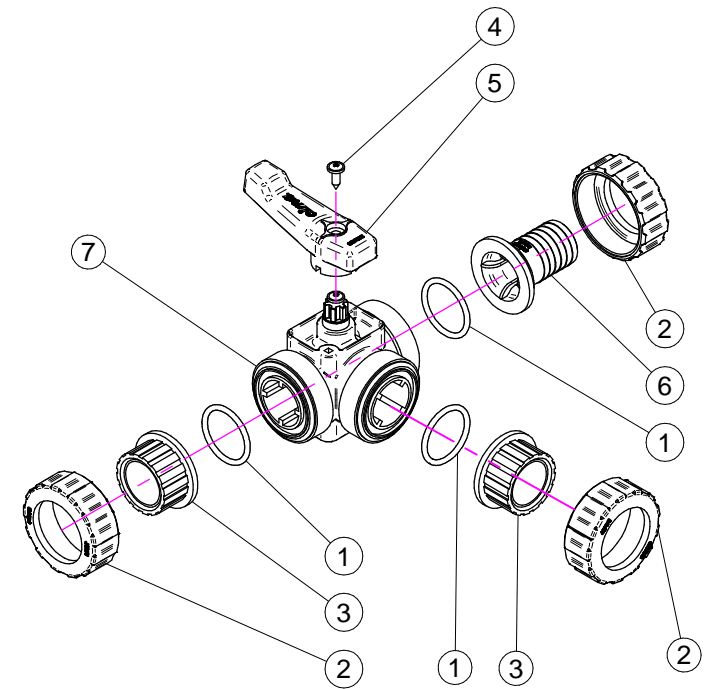
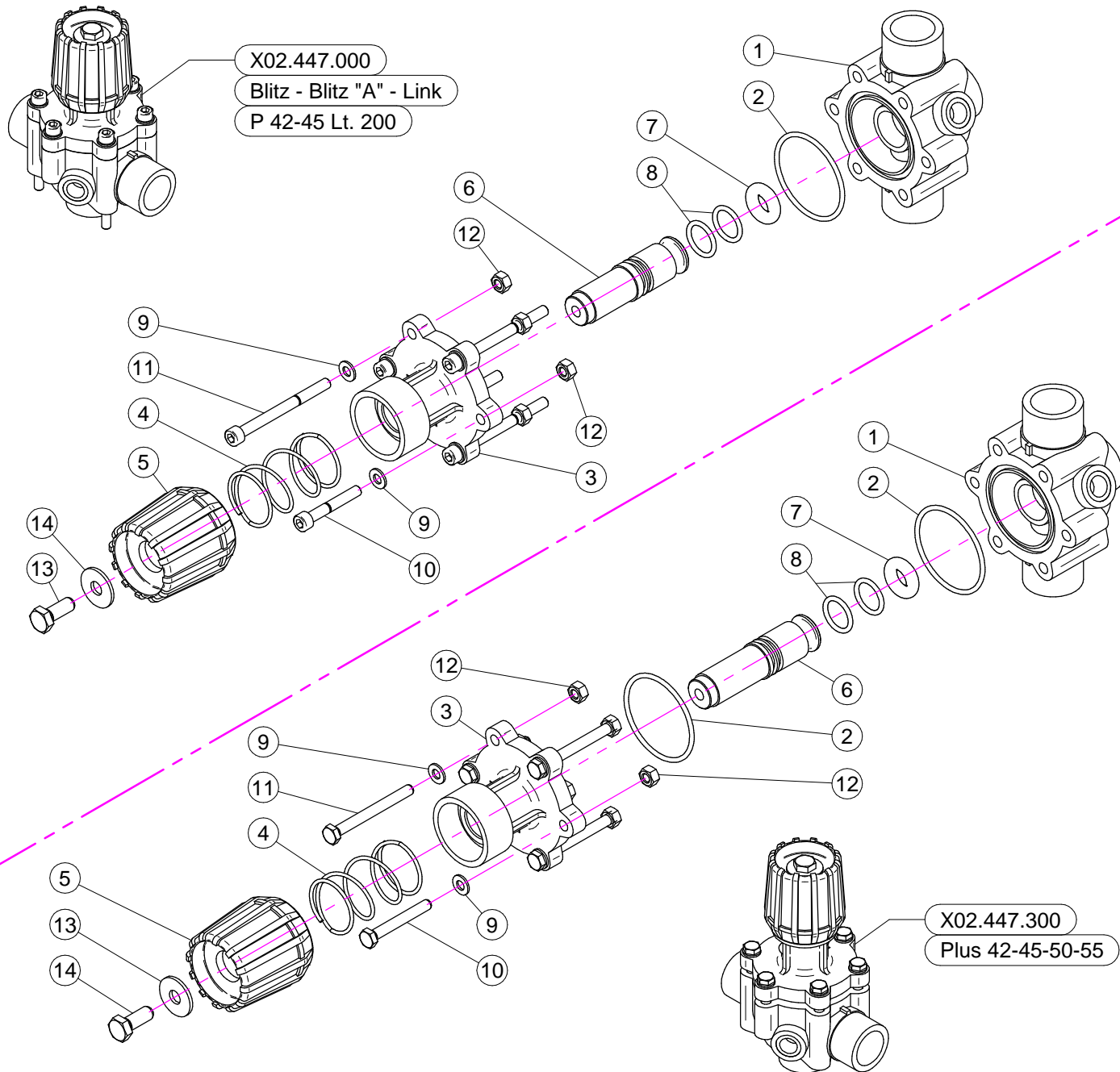

BLITZ - BLITZ "A" - LINK

N°	Doc. Number	Titolo	Title	Q.tà	Note
1	X02.447.001	CORPO VALVOLA DI REGOLAZIONE	BODY FOR REGULATION VALVE	1	
2	XOR.003.193	OR D.48,89x2,62	O-RING GASKET 48,89x2,62	1	
3	X02.447.009	FLANGIA SUPERIORE SERRANDA	UPPER FLANGE	1	
4	X02.447.011	MOLLA RECUPERO GIOCO	SPRING	1	
5	X02.447.010	MANOPOLA VALVOLA	REGULATION VALVE KNOB	1	
6	X02.447.014	PERNO PER REGOLATORE DI PRESSIONE	PIN	1	
7	X02.447.005	OR SPECIALE PER SERRANDA 2447	SPECIAL O-RING FOR GATE 2447	1	
8	XOR.003.068	OR D.17,12x2,62	O-RING GASKET 17,12x2,62	2	
9	XRP.006.000	RONDELLA PIANA D. 6	WASHER D.6	6	
10	XTCE.006 .040	VITE BRUGOLA TCE M6x40	BOLT TCE M6x40	2	
11	XTCE.006.070	VITE BRUGOLA TCE M6x70	BOLT TCE M6x70	4	
12	XD0.06.5588G	DADO M6	NUT M6	6	
13	XTE.008.025I	VITE TE 8X25 INOX	INOX 8X25 SCREW	1	
14	XRP.008.024I	RONDELLA PIANA LARGA D.8X24 INOX	INOX WASHER D.8X24	1	

PLUS 42-45-50-55

N°	Doc. Number	Titolo	Title	Q.tà	Note
1	X02.447.001	CORPO VALVOLA DI REGOLAZIONE	BODY FOR REGULATION VALVE	1	
2	XOR.003.193	OR D.48,89x2,62	O-RING GASKET 48,89x2,62	2	
3	X02.447.012	FLANGIA SUPERIORE SERRANDA	UPPER FLANGE	1	
4	X02.447.011	MOLLA RECUPERO GIOCO	SPRING	1	
5	X02.447.010	MANOPOLA VALVOLA	REGULATION VALVE KNOB	1	
6	X02.447.013	PERNO IN NYLON PER VALVOLA	VALVE PIN	1	
7	X02.447.005	OR SPECIALE PER SERRANDA 2447	SPECIAL O-RING FOR GATE 2447	1	
8	XOR.003.068	OR D.17,12x2,62	O-RING GASKET 17,12x2,62	2	
9	XRP.006.000I	RONDELLA PIANA D. 6 INOX	INOX WASHER D.6	6	
10	XTE.006.045I	VITE TE M6x45 INOX	INOX M6x45 SCREW	2	
11	XTE.006.060I	VITE TE M6x60 INOX	INOX M6x60 TE SCREW	4	
12	XD0.06.5588GI	DADO M6 6S PG INOX	INOX M6 6S BIG LEAD NUT 5588	6	
13	XRP.008.024I	RONDELLA PIANA LARGA D.8X24 INOX	INOX WASHER D.8X24	1	
14	XTE.008.025I	VITE TE 8X25 INOX	INOX 8X25 SCREW	1	

N°	Doc. Number	Titolo	Title	Q.tà
1	XOR.004.137	OR D.34.52x3.53	O-RING D.34.52x3.53	3
2	X21.058.007	GHIERA VALVOLA 3 VIE	VALVE UNION NUT	3
3	X21.058.006	MANICOTTO VALVOLA 3 VIE	VALVE END CONNECTOR	2
4	XTA.05.5.016	VITE AUTOFILETTANTE M5,5 x 16	SELFTHREATED SCREW M5,5 x 16	1
5	X21.058.003	MANIGLIA VALVOLA 3 VIE	VALVE HANDLE	1
6	X21.058.009	PORTAGOMMA D.30 RUBINETTO A 3 VIE	RUBBER HOLDER D.30	1
7	X21.058.110	CORPO VALVOLA 3 VIE	BODY OF THREE WAYS VALVE	1

CODICE-CODE
X02.450.100

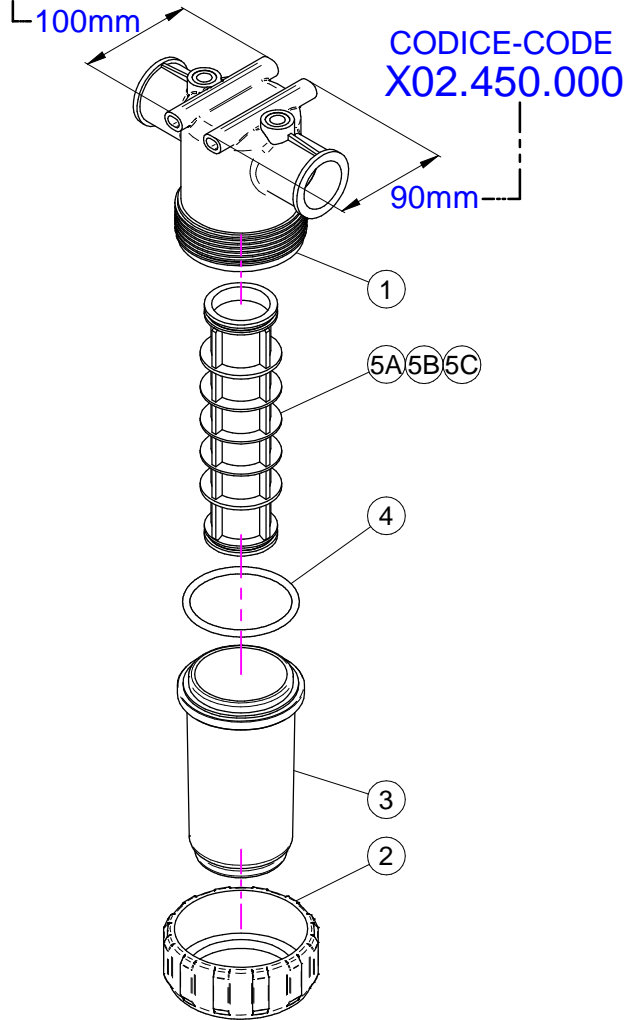

CODICE-CODE
X02.450.110

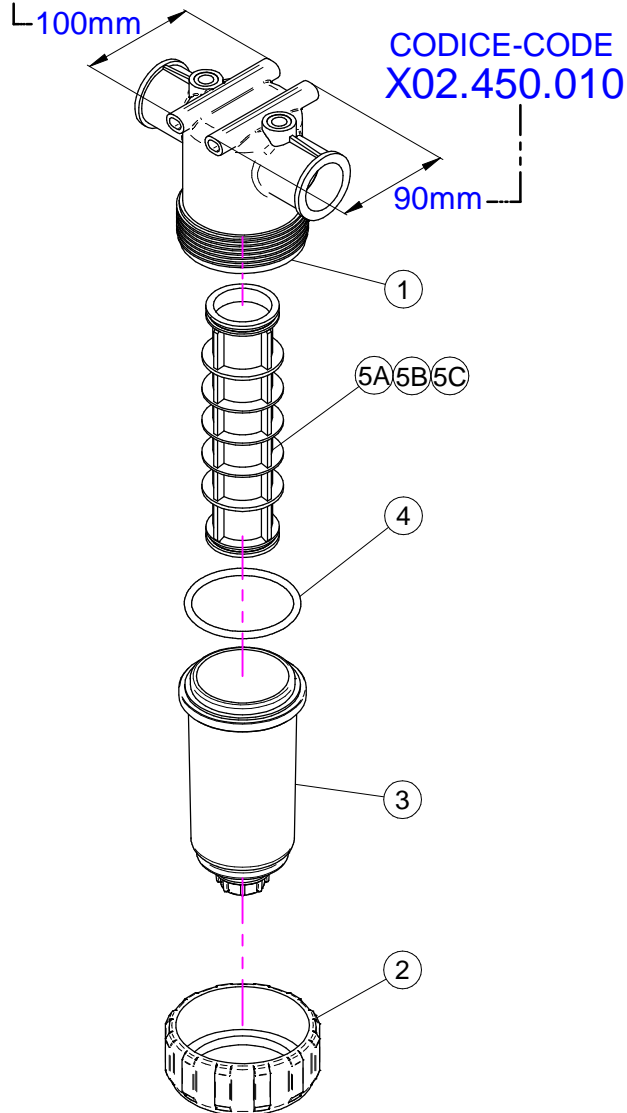

CODICE-CODE
X02.450.120

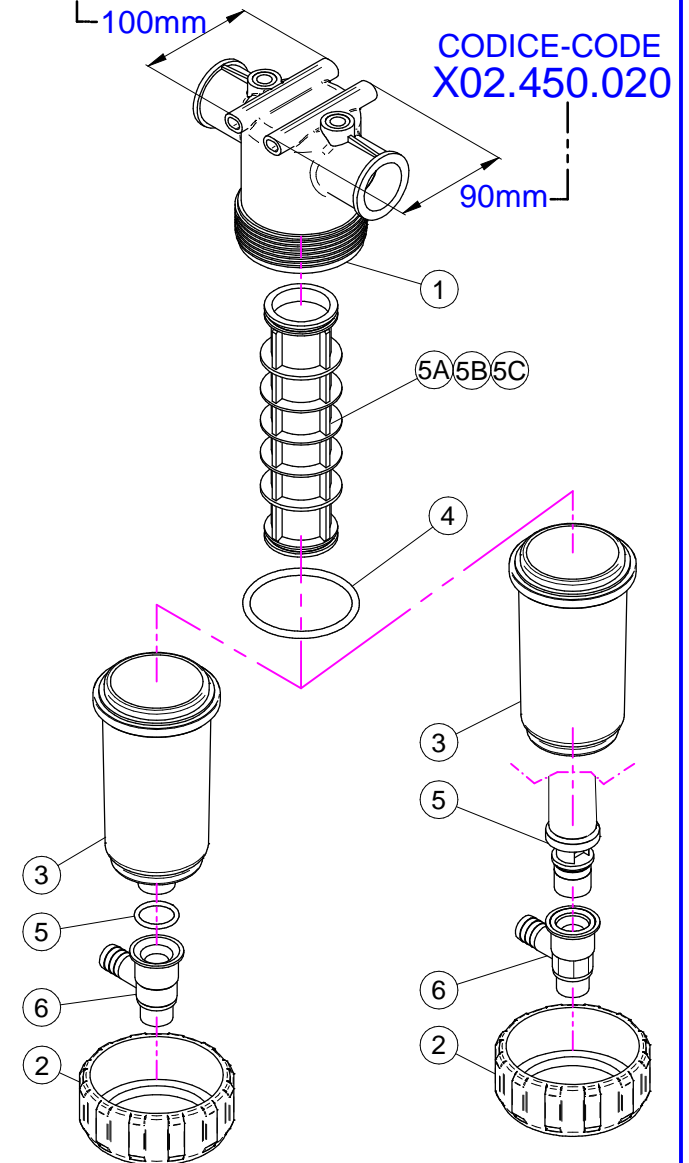

X02.450.100

N°	Doc. Number	Titolo	Title	Q.tà	Note
1	X02.450.101	CORPO FILTRO IN LINEA F. 1 1/4"	LINE FILTER BODY	1	
2	X02.450.003	GHIERA FILTRO IN LINEA	RING NUT FILTER IN LINE	1	
3	X02.450.002	COPERCHIO FILTRO	LID FILTER	1	
4	XOR.000.178	OR D.74,63x5,33	O-RING D.74,63x5,33	1	
5A	X02.450.004C	CARTUCCIA FILTRO CON OR 50 MESH (BLU)	CARTRIDGE WITH O-RING 50 MESH (BLUE)	1	
5B	X02.450.204C	CARTUCCIA FILTRO CON OR 80 MESH (GRIGIO)	CARTRIDGE WITH O-RING 80 MESH (GREY)	1	
5C	X02.450.104C	CARTUCCIA FILTRO CON OR 32 MESH (BIANCO)	CARTRIDGE WITH O-RING 32 MESH (WHITE)	1	

X02.450.000

N°	Doc. Number	Titolo	Title	Q.tà	Note
1	X02.450.001	CORPO FILTRO IN LINEA F. 1 1/4"	LINE FILTER BODY	1	
2	X02.450.003	GHIERA FILTRO IN LINEA	RING NUT FILTER IN LINE	1	
3	X02.450.002	COPERCHIO FILTRO	LID FILTER	1	
4	XOR.000.178	OR D.74,63x5,33	O-RING D.74,63x5,33	1	
5A	X02.450.004C	CARTUCCIA FILTRO CON OR 50 MESH (BLU)	CARTRIDGE WITH O-RING 50 MESH (BLUE)	1	
5B	X02.450.204C	CARTUCCIA FILTRO CON OR 80 MESH (GRIGIO)	CARTRIDGE WITH O-RING 80 MESH (GREY)	1	
5C	X02.450.104C	CARTUCCIA FILTRO CON OR 32 MESH (BIANCO)	CARTRIDGE WITH O-RING 32 MESH (WHITE)	1	

X02.450.110

N°	Doc. Number	Titolo	Title	Q.tà	Note
1	X02.450.101	CORPO FILTRO IN LINEA F. 1 1/4"	LINE FILTER BODY	1	
2	X02.450.003	GHIERA FILTRO IN LINEA	RING NUT FILTER IN LINE	1	
3	X02.450.011	COPERCHIO FILTRO CON SCARICO D.3/4"	LID FILTER WITH UNLOADING	1	
4	XOR.000.178	OR D.74,63x5,33	O-RING D.74,63x5,33	1	
5	X02.182.000	TAPPO 3/4" FEMMINA	FEMALE 3/4" CAP	1	
6	X02.030.010	GUARNIZIONE TAPPO DISTRIBUTORE	GASKET	1	
5A	X02.450.004C	CARTUCCIA FILTRO CON OR 50 MESH (BLU)	CARTRIDGE WITH O-RING 50 MESH (BLUE)	1	
5B	X02.450.204C	CARTUCCIA FILTRO CON OR 80 MESH (GRIGIO)	CARTRIDGE WITH O-RING 80 MESH (GREY)	1	
5C	X02.450.104C	CARTUCCIA FILTRO CON OR 32 MESH (BIANCO)	CARTRIDGE WITH O-RING 32 MESH (WHITE)	1	

X02.450.010

N°	Doc. Number	Titolo	Title	Q.tà	Note
1	X02.450.001	CORPO FILTRO IN LINEA F. 1 1/4"	LINE FILTER BODY	1	
2	X02.450.003	GHIERA FILTRO IN LINEA	RING NUT FILTER IN LINE	1	
3	X02.450.011	COPERCHIO FILTRO CON SCARICO D.3/4"	LID FILTER WITH UNLOADING	1	
4	XOR.000.178	OR D.74,63x5,33	O-RING D.74,63x5,33	1	
5	X02.182.000	TAPPO 3/4" FEMMINA	FEMALE 3/4" CAP	1	
6	X02.030.010	GUARNIZIONE TAPPO DISTRIBUTORE	GASKET	1	
5A	X02.450.004C	CARTUCCIA FILTRO CON OR 50 MESH (BLU)	CARTRIDGE WITH O-RING 50 MESH (BLUE)	1	
5B	X02.450.204C	CARTUCCIA FILTRO CON OR 80 MESH (GRIGIO)	CARTRIDGE WITH O-RING 80 MESH (GREY)	1	
5C	X02.450.104C	CARTUCCIA FILTRO CON OR 32 MESH (BIANCO)	CARTRIDGE WITH O-RING 32 MESH (WHITE)	1	

X02.450.120

N°	Doc. Number	Titolo	Title	Q.tà	Note
1	X02.450.101	CORPO FILTRO IN LINEA F. 1 1/4"	LINE FILTER BODY	1	
2	X02.450.003	GHIERA FILTRO IN LINEA	RING NUT FILTER IN LINE	1	
3	X02.450.011	COPERCHIO FILTRO CON SCARICO D.3/4"	LID FILTER WITH UNLOADING	1	
4	XOR.000.178	OR D.74,63x5,33	O-RING D.74,63x5,33	1	
5	XOR.000.134	OR D.25,8x3,53	O-RING D.25,8x3,53	1	
6	X02.450.120.D	RUBINETTO AUTOPULENTE PER FILTRO	FAUCET FOR FILTER	1	
7A	X02.450.004C	CARTUCCIA FILTRO CON OR 50 MESH (BLU)	CARTRIDGE WITH O-RING 50 MESH (BLUE)	1	
7B	X02.450.204C	CARTUCCIA FILTRO CON OR 80 MESH (GRIGIO)	CARTRIDGE WITH O-RING 80 MESH (GREY)	1	
7C	X02.450.104C	CARTUCCIA FILTRO CON OR 32 MESH (BIANCO)	CARTRIDGE WITH O-RING 32 MESH (WHITE)	1	

X02.450.020

N°	Doc. Number	Titolo	Title	Q.tà	Note
1	X02.450.001	CORPO FILTRO IN LINEA F. 1 1/4"	LINE FILTER BODY	1	
2	X02.450.003	GHIERA FILTRO IN LINEA	RING NUT FILTER IN LINE	1	
3	X02.450.020.A	COPERCHIO FILTRO IN LINEA 1" 1/4	LINE FILTER LID 1" 1/4	1	
4	XOR.000.178	OR D.74,63x5,33	O-RING D.74,63x5,33	1	
5	X02.450.020.B	CORPO CENTRALE CON TAPPO 1" 1/4	CENTRAL BODY WITH CAP 1" 1/4	1	
6	X02.450.020.D	RUBINETTO AUTOPULENTE PER FILTRO	FAUCET FOR FILTER	1	
7A	X02.450.004C	CARTUCCIA FILTRO CON OR 50 MESH (BLU)	CARTRIDGE WITH O-RING 50 MESH (BLUE)	1	
7B	X02.450.204C	CARTUCCIA FILTRO CON OR 80 MESH (GRIGIO)	CARTRIDGE WITH O-RING 80 MESH (GREY)	1	
7C	X02.450.104C	CARTUCCIA FILTRO CON OR 32 MESH (BIANCO)	CARTRIDGE WITH O-RING 32 MESH (WHITE)	1	

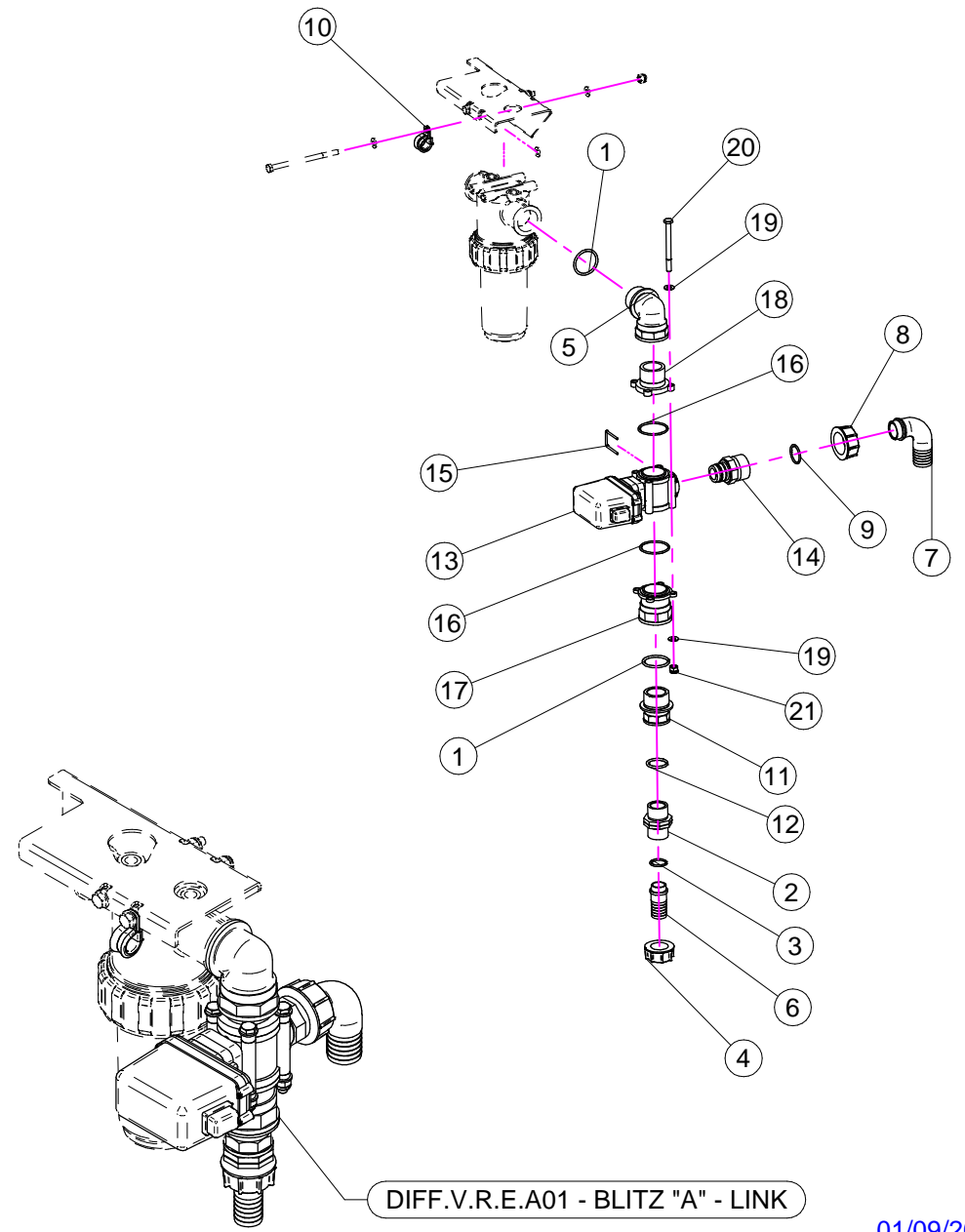
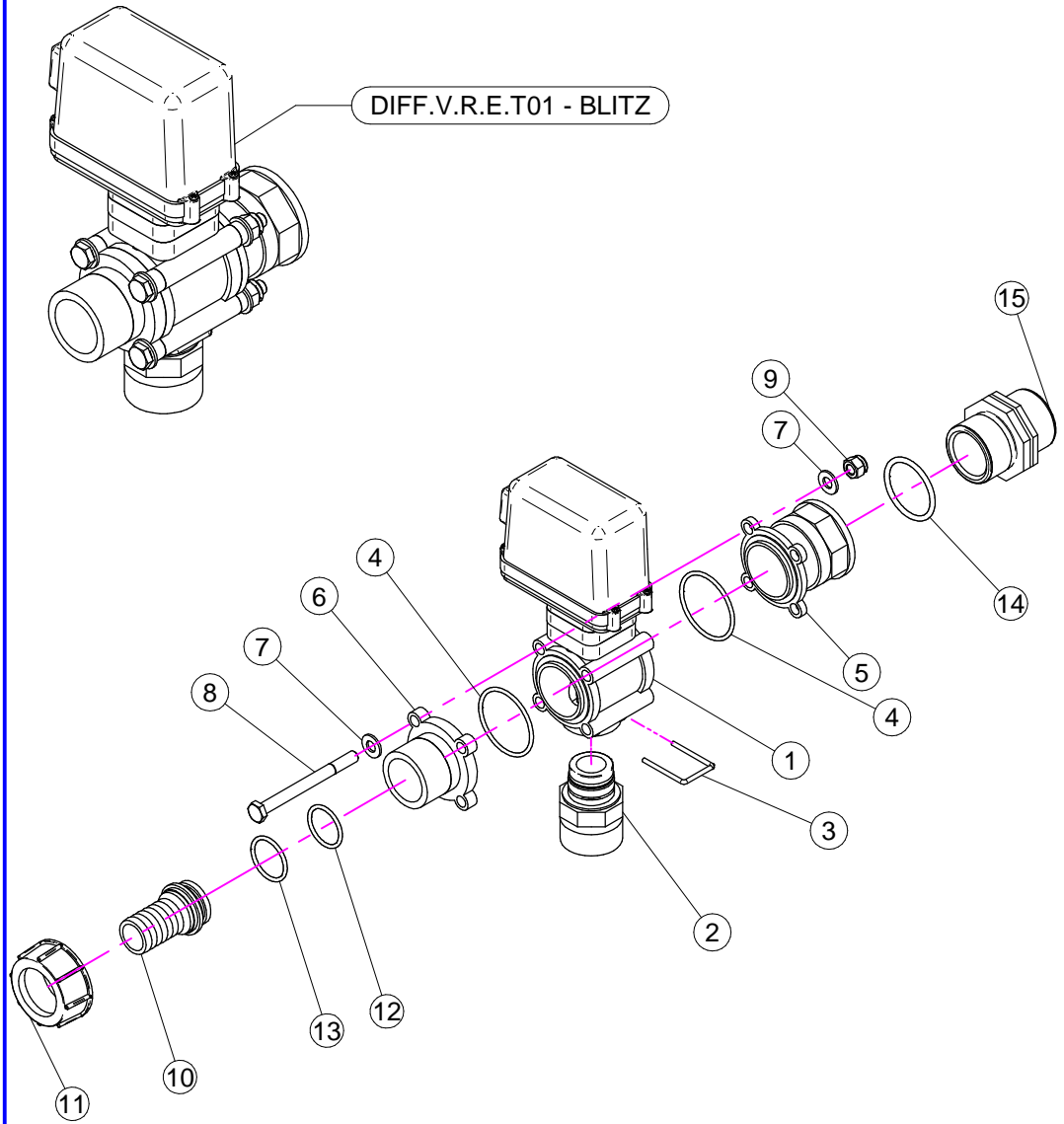

DIFF.V.R.E.T01
BLITZ

N°	Doc. Number	Titolo	Title	Q.tà	Note
1	X21.130.000	VALVOLA MOTORIZZATA PROPORZIONALE	ELECTRIC PROPORTIONAL VALVE	1	
2	X21.131.000	RIDUZIONE ATT.RAP. G 1" 1/4	REDUCTION J. F. G 1" 1/4	1	
3	X21.130.005	FORCHETTA ATTACCO RAPIDO	FORK FASTNER JOINT	1	
4	XOR.003.181	OR D. 45,69x50,93x2,62	45,69x50,93x2,62 O-RING	2	
5	X21.133.000	RACCORDO FLANGIATO 1" - 1 1/4"	CONNECTOR	1	
6	X21.132.000	FLANGIA VALVOLE	VALVE FLANGE	1	
7	XRP.008.000	RONDELLA PIANA D.8	WASHER D.8	8	
8	XTE.008.090	VITE TE M8 x 90	SCREW TE M8 x 90	4	
9	XDA.008.0AG	DADO AUTOBLOCCANTE M8	SELF LOCKING NUT M8	4	
10	X02.363.000	RACCORDO DIRITTO PG D.25 - 1 1/4	STRAIGHT HOSE R.H D.25 - 1 1/4	1	
11	X00.058.006	GIRELLO 1" 1/4 GAS	1" 1/4 FLY NUT	1	
12	XOR.003.106	OR D.26.65x2.62	O-RING D.26.65x2.62	1	
13	XOR.003.112	OR D.28,24x2,62	O-RING D.28,24x2,62	1	
14	XOR.000.144	OR D.39,69x3,53	O-RING D.39,69x3,53	1	
15	X00.345.010	NIPPLO 1" 1/4 + 1" 1/4 GAS	NIPPLE 1" 1/4 + 1" 1/4 GAS	1	

DIFF.V.R.E.A01
BLITZ "A" - LINK

N°	Doc. Number	Titolo	Title	Q.tà	Note
1	XOR.000.144	OR D.39,69x3,53	O-RING D.39,69x3,53	2	
2	X00.055.034	NIPPLO 1" / 1" GAS	NIPPLE 1" / 1" GAS	1	
3	XOR.000.132	OR D.23,81 x 2,62	23,81 x 2,62 O-RING GASKET	1	
4	X00.055.24.2	GIRELLO 1" GAS	1" FLY NUT	1	
5	X24.070.000	RACCORDO CURVO M-F 1"1/4	HOSETAIL 1"1/4	1	
6	X00.055.021	RACCORDO DIRITTO PG D.25	STRAIGHT HOSE R.H D.25	1	
7	X00.058.004	RACCORDO CURVO P.G. D.30	D.30 HOSETAIL	1	
8	X00.058.006	GIRELLO 1" 1/4 GAS	1" 1/4 FLY NUT	1	
9	XOR.003.112	OR D.28,24x2,62	O-RING D.28,24x2,62	1	
10	XFG.018.000	FASCETTA GOMMATA PER TUBI D.18	STICKER	1	
11	X02.374.000	RIDUZIONE M/F 1"F / 1"1/4M	M. / F. 1"F / 1"1/4M REDUCTION	1	
12	XOR.004.118	OR D.29,75 x 3,53	29,75 x 3,53 O-RING GASKET	1	
13	X21.130.000	VALVOLA MOTORIZZATA PROPORZIONALE	ELECTRIC PROPORTIONAL VALVE	1	
14	X21.131.000	RIDUZIONE ATT.RAP. G 1" 1/4	REDUCTION J. F. G 1" 1/4	1	
15	X21.130.005	FORCHETTA ATTACCO RAPIDO	FORK FASTNER JOINT	1	
16	XOR.003.181	OR D. 45,69x50,93x2,62	45,69x50,93x2,62 O-RING	2	
17	X21.133.000	RACCORDO FLANGIATO 1" - 1 1/4"	CONNECTOR	1	
18	X21.132.000	FLANGIA VALVOLE	VALVE FLANGE	1	
19	XRP.008.000	RONDELLA PIANA D.8	WASHER D.8	8	
20	XTE.008.090	VITE TE M8 x 90	SCREW TE M8 x 90	4	
21	XDA.008.0AG	DADO AUTOBLOCCANTE M8	SELF LOCKING NUT M8	4	

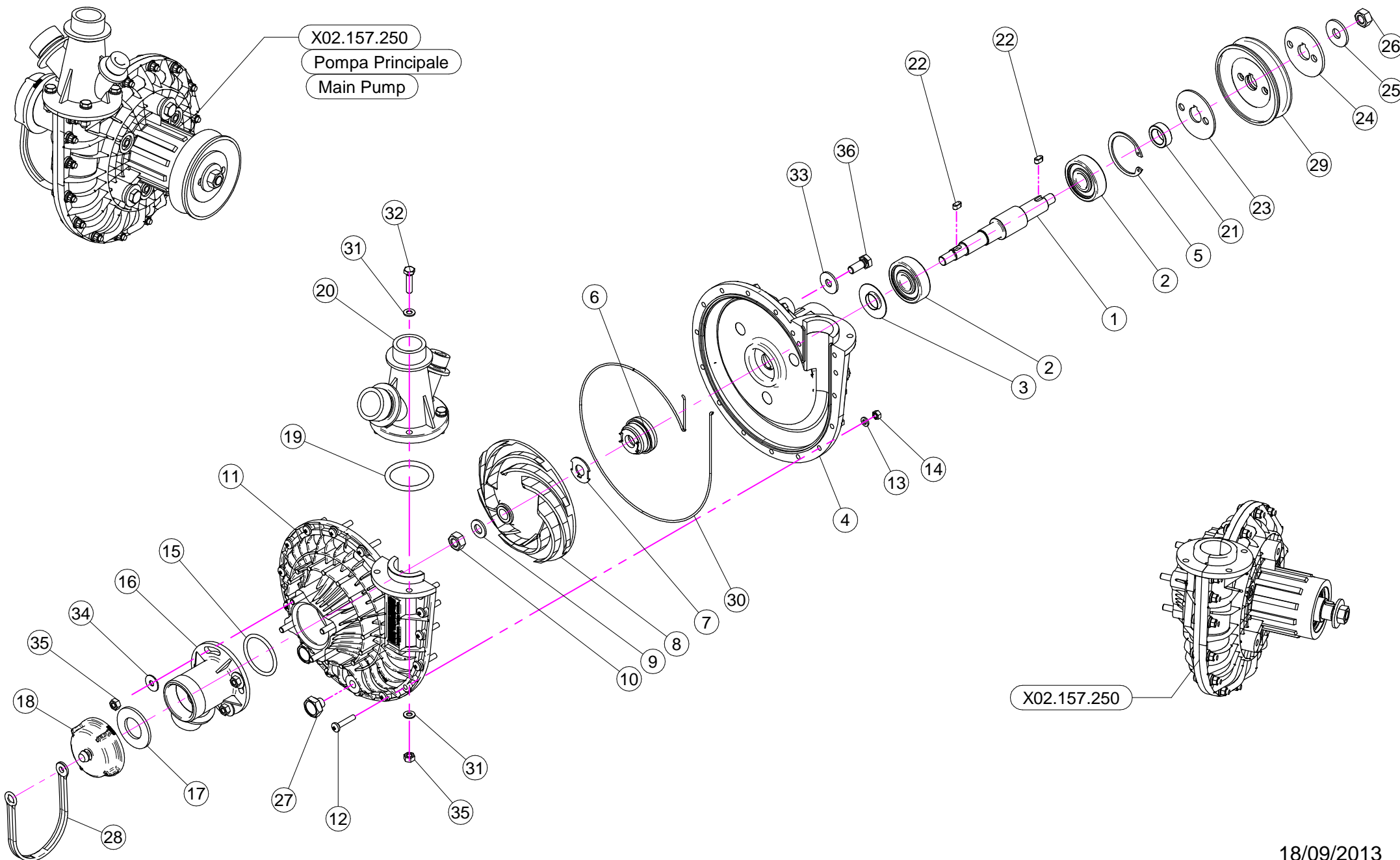

N°	Doc. Number	Titolo	Title	Q.tà	Note
1	X02.155.010	ALBERO POMPA CD 32 INOX LUNGO	CD32 PUMP SHAFT	1	
2	XK6.303.2RS	CUSCINETTO A SFERE	ROLLER BEARING	2	
3	X20.406.000	COPERCHIETTO SPECIALE POMPA CD 32	SPECIAL COVER FOR PUMP	1	
4	X02.151.011	CORPO POMPA CD 32 LUNGO	PUMP CASING MODEL 2013	1	
5	XI0.047.000	ANELLO ELASTICO INTERNO D.47	INTERNAL D.47 CIRCLIP	1	
6	X00.085.024CS	TENUTA MECCANICA	MECHANICAL SEAL	1	
7	X02.114.000	RONDELLA SPECIALE INOX	INOX SPECIAL WASHER	1	
8	X02.153.000	GIRANTE POMPA CD 32	CD 32 PUMP IMPELLER	1	
9	XRP.010.00I	RONDELLA PIANA D.10 INOX	WASHER D.10 INOX	1	
10	XDOT.10.5587	DADO OTTONE M10	M10 BRASS NUT	1	
11	X02.152.010	COPERCHIO POMPA CD 32	HOUSING	1	
12	XTC.05.25.85	VITE TESTA A CROCE 48 M5X25	CROSS SLOTTED SCREW M5X25	17	
13	XRP.005.000	RONDELLA PIANA D.5	WASHER D.5	17	
14	XDOT.05.5587	DADO OTTONE M5 (5587)	M5 BRASS NUT (5587)	17	
15	XOR.000.144	OR D.39,69x3,53	O-RING D.39,69x3,53	1	
16	X02.116.000	RACCORDO DI ASPIRAZIONE	SUCTION FITTING	1	
17	X02.130.000	GUARNIZIONE IN GOMMA DIAM. 24X46X3	24X46X3 RUBBER GASKET	1	
18	X02.120.000	TAPPO A FILETTO RAPIDO M47 x 5	RAPID THREAD CAP	1	
19	XOR.006.162	OR D.40,65 x 5,34	O-RING GASKET 40,65 x 5,34	1	
20	X02.113.001	RACCORDO DI MANDATA	DELIVERY FITTING	1	
21	X02.722.000	DISTANZIALE POMPA	BUSH	1	
22	XL.05.05.10	LINGUETTA 5X5X10	5X5X10 TANG	2	
23	X02.723.005	RONDELLA SPECIALE mm2	SPECIAL WASHER mm2	1	
24	X02.723.001	RONDELLA SPECIALE mm3	SPECIAL WASHER mm3	1	
25	XRP.010.030	RONDELLA PIANA D.10 x 30 mm	WASHER D.10 x 30 mm	1	
26	XD0.10.5588G	DADO M 10 6S PG	M10 6S BIG LEAD NUT 5588	1	
27	XTM.010.015	TAPPO M10X1,5	M10X1,5 CAP	2	
28	X21.183.000	STRISCIA FERMATAPPI	CAP STOP	1	
29	X02.723.002	PULEGGIA COMANDO POMPA D.82,5 X 1 3V	PULLEY FOR PUMP D.82,5 X 1 3V	1	
30	XOR.C02.070	CORDA OR D.2 L=700	OR CORD D.2 L=700	1	
31	XRP.006.000	RONDELLA PIANA D. 6	WASHER D.6	8	
32	XTE.006.025T	VITE TE M6X25	SCREW TE M6X25	4	
33	XRP.008.024	RONDELLA PIANA LARGA D.8X24	WASHER D.8X24	3	
34	XRP.006.018	RONDELLA PIANA D. 6x18	WASHER D.6x18	4	
35	XDOT.06.5587	DADO OTTONE M6	M6 BRASS NUT 5587	8	
36	XTE.008.020T	VITE TE 8x20	SCREW TE 8x20	3	

X02.157.063
Pompa Supplementare
Additional Pump

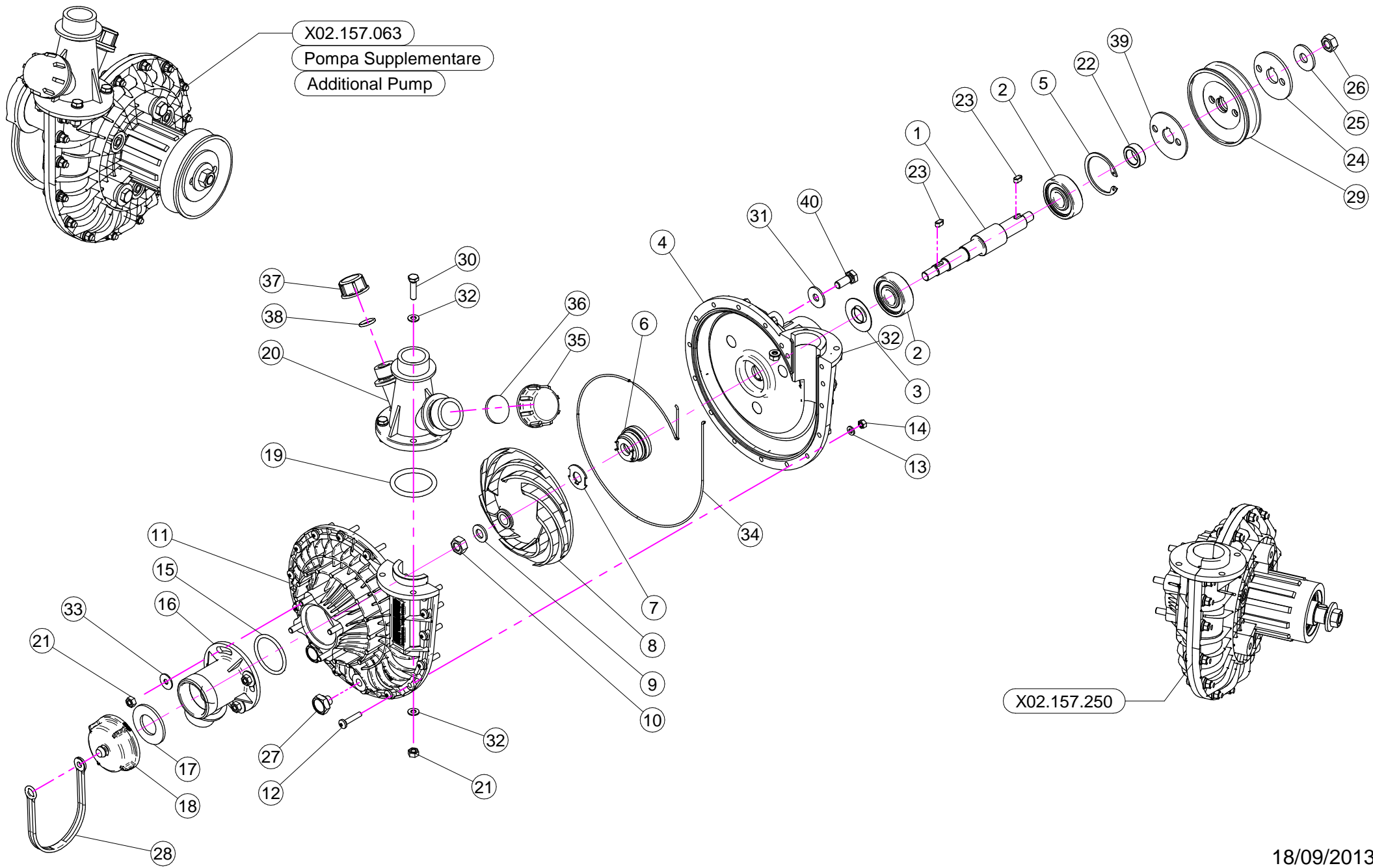

X02.157.250

N°	Doc. Number	Titolo	Title	Q.tà	Note
1	X02.155.010	ALBERO POMPA CD 32 INOX LUNGO	CD32 PUMP SHAFT	1	
2	XK6.303.2RS	CUSCINETTO A SFERE	ROLLER BEARING	2	
3	X20.406.000	COPERCHIETTO SPECIALE POMPA CD 32	SPECIAL COVER FOR PUMP	1	
4	X02.151.011	CORPO POMPA CD 32 LUNGO	PUMP CASING MODEL 2013	1	
5	XI0.047.000	ANELLO ELASTICO INTERNO D.47	INTERNAL D.47 CIRCLIP	1	
6	X00.085.024CS	TENUTA MECCANICA	MECHANICAL SEAL	1	
7	X02.114.000	RONDELLA SPECIALE INOX	INOX SPECIAL WASHER	1	
8	X02.153.000	GIRANTE POMPA CD 32	CD 32 PUMP IMPELLER	1	
9	XRP.010.001	RONDELLA PIANA D.10 INOX	WASHER D.10 INOX	1	
10	XDOT.10.5587	DADO OTTONE M10	M10 BRASS NUT	1	
11	X02.152.010	COPERCHIO POMPA CD 32	HOUSING	1	
12	XTC.05.25.85	VITE TESTA A CROCE 48 M5X25	CROSS SLOTTED SCREW M5X25	17	
13	XRP.005.000	RONDELLA PIANA D.5	WASHER D.5	17	
14	XDOT.05.5587	DADO OTTONE M5 (5587)	M5 BRASS NUT (5587)	17	
15	XOR.000.144	OR D.39,69x3,53	O-RING D.39,69x3,53	1	
16	X02.116.000	RACCORDO DI ASPIRAZIONE	SUCTION FITTING	1	
17	X02.130.000	GUARNIZIONE IN GOMMA DIAM. 24X46X3	24X46X3 RUBBER GASKET	1	
18	X02.120.000	TAPPO A FILETTO RAPIDO M47 x 5	RAPID THREAD CAP	1	
19	XOR.006.162	OR D.40,65 x 5,34	O-RING GASKET 40,65 x 5,34	1	
20	X02.113.001	RACCORDO DI MANDATA	DELIVERY FITTING	1	
21	XDOT.06.5587	DADO OTTONE M6	M6 BRASS NUT 5587	8	
22	X02.722.000	DISTANZIALE POMPA	BUSH	1	
23	XL.05.05.10	LINGUETTA 5X5X10	5X5X10 TANG	2	
24	X02.723.001	RONDELLA SPECIALE mm3	SPECIAL WASHER mm3	1	
25	XRP.010.030	RONDELLA PIANA D.10 x 30 mm	WASHER D.10 x 30 mm	1	
26	XD0.10.5588G	DADO M 10 6S PG	M10 6S BIG LEAD NUT 5588	1	
27	XTM.010.015	TAPPO M10X1,5	M10X1,5 CAP	2	
28	X21.183.000	STRISCIA FERMATAPPI	CAP STOP	1	
29	X02.723.002	PULEGGIA COMANDO POMPA D.82,5 X 1 3V	PULLEY FOR PUMP D.82,5 X 1 3V	1	
30	XTE.006.025T	VITE TE M6X25	SCREW TE M6X25	4	
31	XRP.008.024	RONDELLA PIANA LARGA D.8X24	WASHER D.8X24	3	
32	XRP.006.000	RONDELLA PIANA D. 6	WASHER D.6	8	
33	XRP.006.018	RONDELLA PIANA D. 6x18	WASHER D.6x18	4	
34	XOR.C02.070	CORDA OR D.2 L=700	OR CORD D.2 L=700	1	
35	XTF.001.000	TAPPO 1"	PACKING	1	
36	X24.100.000	GUARNIZIONE PIANA D.30x3 PER TAPPO D. 1"	GASKET D.30 x 3	1	
37	XTF.012.000	TAPPO F. DA 1/2" GAS	BLANK CAP 1/2"	1	
38	XOR.000.117	OR D. 13,1x18,34x2,62	13,1x18,34x2;62 O-RING GASKET	1	
39	X02.723.005	RONDELLA SPECIALE mm2	SPECIAL WASHER mm2	1	
40	XTE.008.020T	VITE TE 8x20	SCREW TE 8x20	3	

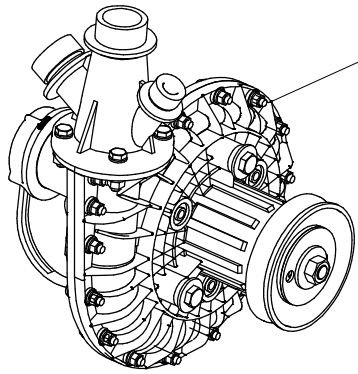

X02.157.072
Pompa Principale
Main Pump

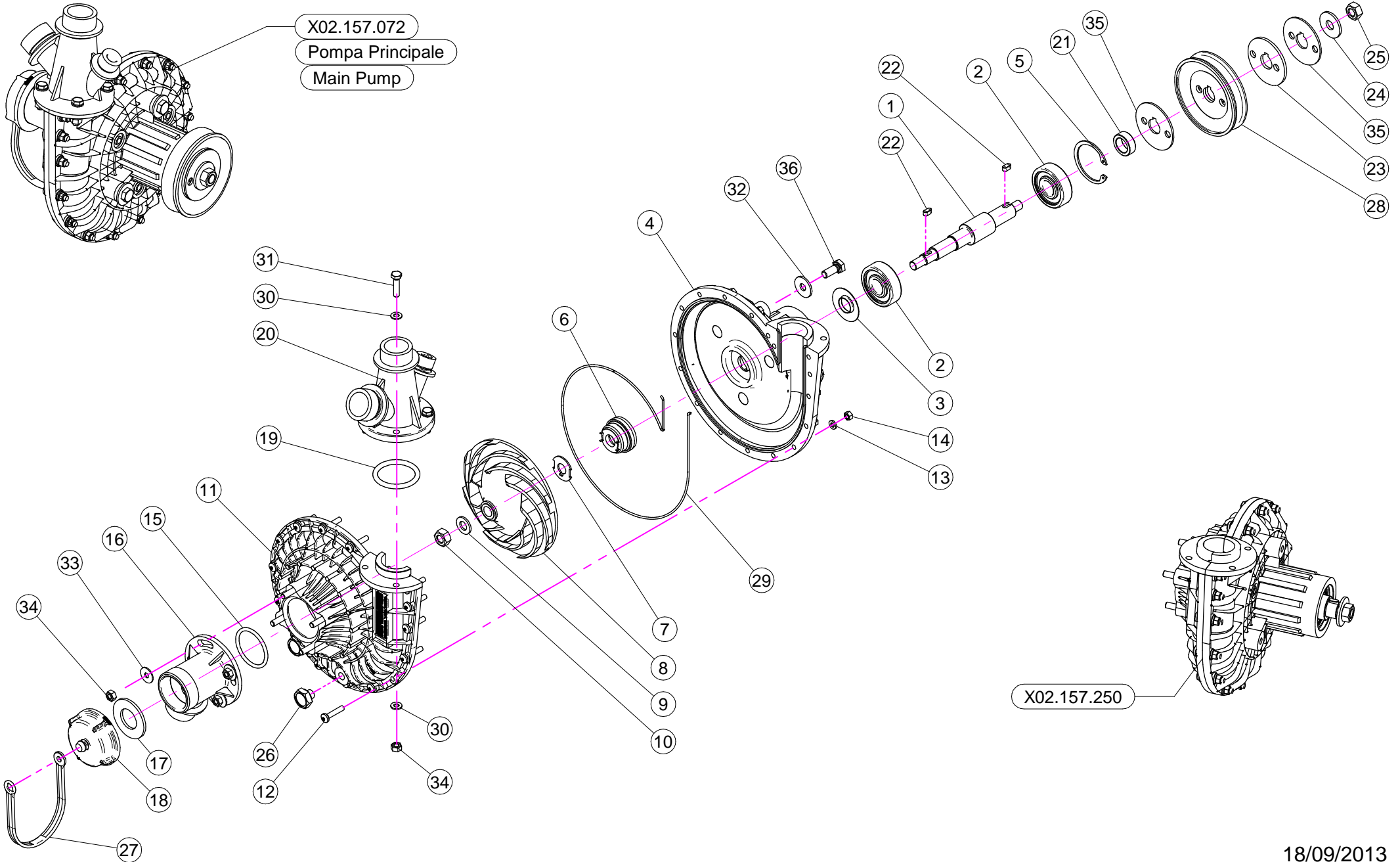

N°	Doc. Number	Titolo	Title	Q.tà	Note
1	X02.155.010	ALBERO POMPA CD 32 INOX LUNGO	CD32 PUMP SHAFT	1	
2	XK6.303.2RS	CUSCINETTO A SFERE	ROLLER BEARING	2	
3	X20.406.000	COPERCHIETTO SPECIALE POMPA CD 32	SPECIAL COVER FOR PUMP	1	
4	X02.151.011	CORPO POMPA CD 32 LUNGO	PUMP CASING MODEL 2013	1	
5	XI0.047.000	ANELLO ELASTICO INTERNO D.47	INTERNAL D.47 CIRCLIP	1	
6	X00.085.024CS	TENUTA MECCANICA	MECHANICAL SEAL	1	
7	X02.114.000	RONDELLA SPECIALE INOX	INOX SPECIAL WASHER	1	
8	X02.153.000	GIRANTE POMPA CD 32	CD 32 PUMP IMPELLER	1	
9	XRP.010.00I	RONDELLA PIANA D.10 INOX	WASHER D.10 INOX	1	
10	XDOT.10.5587	DADO OTTONE M10	M10 BRASS NUT	1	
11	X02.152.010	COPERCHIO POMPA CD 32	HOUSING	1	
12	XTC.05.25.85	VITE TESTA A CROCE 48 M5X25	CROSS SLOTTED SCREW M5X25	17	
13	XRP.005.000	RONDELLA PIANA D.5	WASHER D.5	17	
14	XDOT.05.5587	DADO OTTONE M5 (5587)	M5 BRASS NUT (5587)	17	
15	XOR.000.144	OR D.39,69x3,53	O-RING D.39,69x3,53	1	
16	X02.116.000	RACCORDO DI ASPIRAZIONE	SUCTION FITTING	1	
17	X02.130.000	GUARNIZIONE IN GOMMA DIAM. 24X46X3	24X46X3 RUBBER GASKET	1	
18	X02.120.000	TAPPO A FILETTO RAPIDO M47 x 5	RAPID THREAD CAP	1	
19	XOR.006.162	OR D.40,65 x 5,34	O-RING GASKET 40,65 x 5,34	1	
20	X02.113.001	RACCORDO DI MANDATA	DELIVERY FITTING	1	
21	X02.722.000	DISTANZIALE POMPA	BUSH	1	
22	XL.05.05.10	LINGUETTA 5X5X10	5X5X10 TANG	2	
23	X02.723.001	RONDELLA SPECIALE mm3	SPECIAL WASHER mm3	1	
24	XRP.010.030	RONDELLA PIANA D.10 x 30 mm	WASHER D.10 x 30 mm	1	
25	XD0.10.5588G	DADO M 10 6S PG	M10 6S BIG LEAD NUT 5588	1	
26	XTM.010.015	TAPPO M10X1,5	M10X1,5 CAP	2	
27	X21.183.000	STRISCIA FERMATAPPI	CAP STOP	1	
28	X02.723.000	PULEGGIA COMANDO POMPA D.88 X 1 3V	PULLEY FOR PUMP D.88 X 1 3V	1	
29	XOR.C02.070	CORDA OR D.2 L=700	OR CORD D.2 L=700	1	
30	XRP.006.000	RONDELLA PIANA D. 6	WASHER D.6	8	
31	XTE.006.025T	VITE TE M6X25	SCREW TE M6X25	4	
32	XRP.008.024	RONDELLA PIANA LARGA D.8X24	WASHER D.8X24	3	
33	XRP.006.018	RONDELLA PIANA D. 6x18	WASHER D.6x18	4	
34	XDOT.06.5587	DADO OTTONE M6	M6 BRASS NUT 5587	8	
35	X02.723.005	RONDELLA SPECIALE mm2	SPECIAL WASHER mm2	2	
36	XTE.008.020T	VITE TE 8x20	SCREW TE 8x20	3	

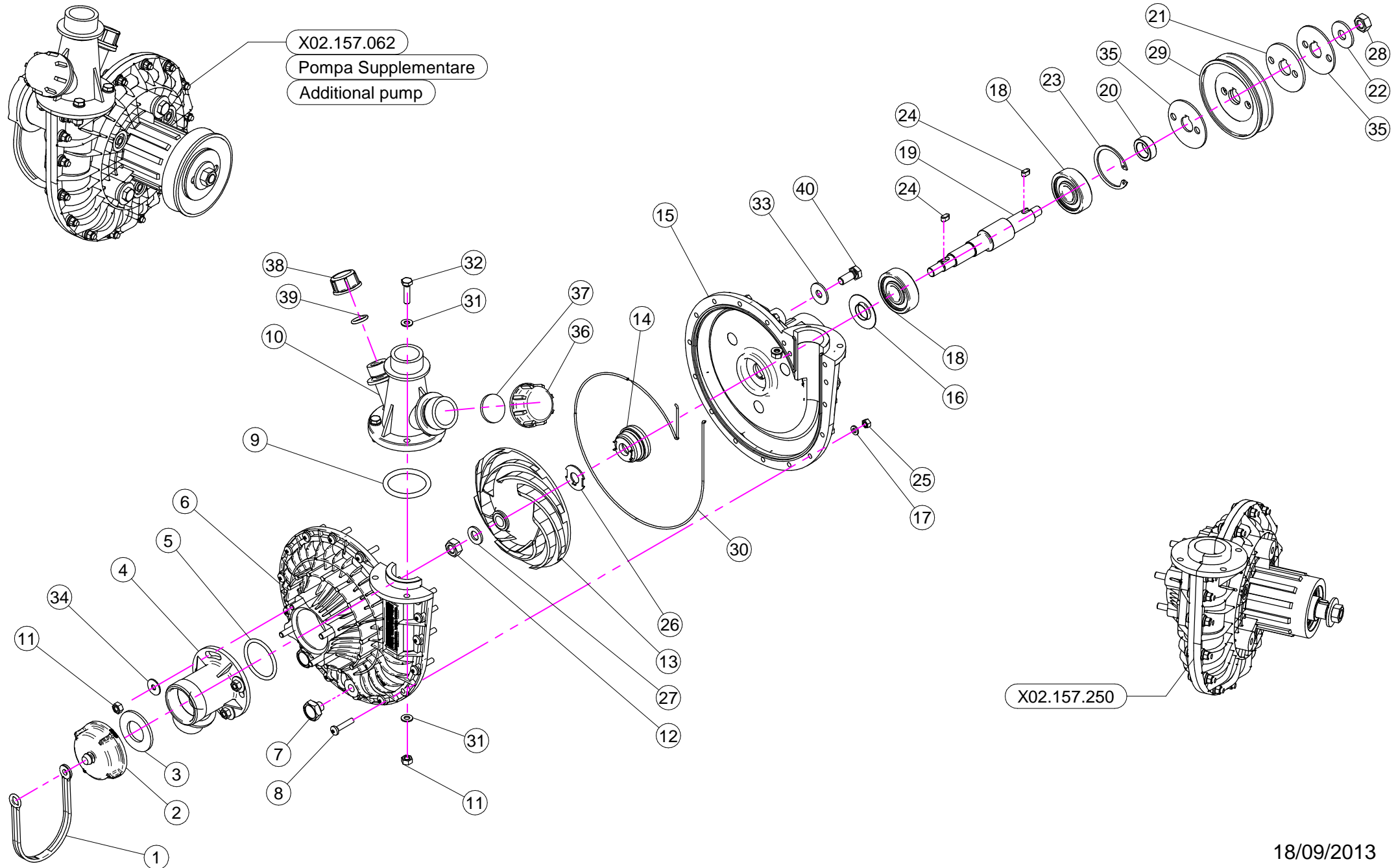

X02.157.250

N°	Doc. Number	Titolo	Title	Qtà	Note
1	X21.183.000	STRISCIA FERMATAPPI	CAP STOP	1	
2	X02.120.000	TAPPO A FILETTO RAPIDO M47 x 5	RAPID THREAD CAP	1	
3	X02.130.000	GUARNIZIONE IN GOMMA DIAM. 24X46X3	24X46X3 RUBBER GASKET	1	
4	X02.116.000	RACCORDO DI ASPIRAZIONE	SUCTION FITTING	1	
5	XOR.000.144	OR D.39,69x3,53	O-RING D.39,69x3,53	1	
6	X02.152.010	COPERCHIO POMPA CD 32	HOUSING	1	
7	XTM.010.015	TAPPO M10X1,5	M10X1,5 CAP	2	
8	XTC.05.25.85	VITE TESTA A CROCE 48 M5X25	CROSS SLOTTED SCREW M5X25	17	
9	XOR.006.162	OR D.40,65 x 5,34	O-RING GASKET 40,65 x 5,34	1	
10	X02.113.001	RACCORDO DI MANDATA	DELIVERY FITTING	1	
11	XDOT.06.5587	DADO OTTONE M6	M6 BRASS NUT 5587	8	
12	XDOT.10.5587	DADO OTTONE M10	M10 BRASS NUT	1	
13	X02.153.000	GIRANTE POMPA CD 32	CD 32 PUMP IMPELLER	1	
14	X00.085.024CS	TENUTA MECCANICA	MECHANICAL SEAL	1	
15	X02.151.011	CORPO POMPA CD 32 LUNGO	PUMP CASING MODEL 2013	1	
16	X20.406.000	COPERCHIETTO SPECIALE POMPA CD 32	SPECIAL COVER FOR PUMP	1	
17	XRP.005.000	RONDELLA PIANA D.5	WASHER D.5	17	
18	XK6.303.2RS	CUSCINETTO A SFERE	ROLLER BEARING	2	
19	X02.155.010	ALBERO POMPA CD 32 INOX LUNGO	CD32 PUMP SHAFT	1	
20	X02.722.000	DISTANZIALE POMPA	BUSH	1	
21	X02.723.001	RONDELLA SPECIALE mm3	SPECIAL WASHER mm3	1	
22	XRP.010.030	RONDELLA PIANA D.10 x 30 mm	WASHER D.10 x 30 mm	1	
23	XI0.047.000	ANELLO ELASTICO INTERNO D.47	INTERNAL D.47 CIRCLIP	1	
24	XL.05.05.10	LINGUETTA 5X5X10	5X5X10 TANG	2	
25	XDOT.05.5587	DADO OTTONE M5 (5587)	M5 BRASS NUT (5587)	17	
26	X02.114.000	RONDELLA SPECIALE INOX	INOX SPECIAL WASHER	1	
27	XRP.010.001	RONDELLA PIANA D.10 INOX	WASHER D.10 INOX	1	
28	XD0.10.5588G	DADO M 10 6S PG	M10 6S BIG LEAD NUT 5588	1	
29	X02.723.000	PULEGGIA COMANDO POMPA D.88 X 1 3V	PULLEY FOR PUMP D.88 X 1 3V	1	
30	XOR.C02.070	CORDA OR D.2 L=700	OR CORD D.2 L=700	1	
31	XRP.006.000	RONDELLA PIANA D. 6	WASHER D.6	8	
32	XTE.006.025T	VITE TE M6X25	SCREW TE M6X25	4	
33	XRP.008.024	RONDELLA PIANA LARGA D.8X24	WASHER D.8X24	3	
34	XRP.006.018	RONDELLA PIANA D. 6x18	WASHER D.6x18	4	
35	X02.723.005	RONDELLA SPECIALE mm2	SPECIAL WASHER mm2	2	
36	XTF.001.000	TAPPO 1"	PACKING	1	
37	X24.100.000	GUARNIZIONE PIANA D.30x3 PER TAPPO D. 1"	GASKET D.30 x 3	1	
38	XTF.012.000	TAPPO F. DA 1/2" GAS	BLANK CAP 1/2"	1	
39	XOR.000.117	OR D. 13,1x18,34x2,62	13,1x18,34x2,62 O-RING GASKET	1	
40	XTE.008.020T	VITE TE 8x20	SCREW TE 8x20	3	

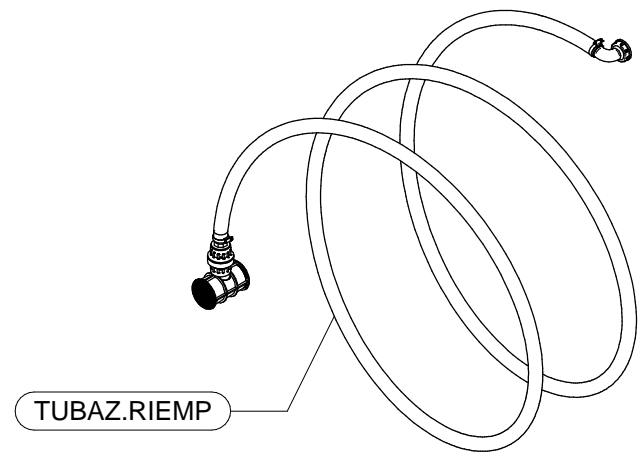
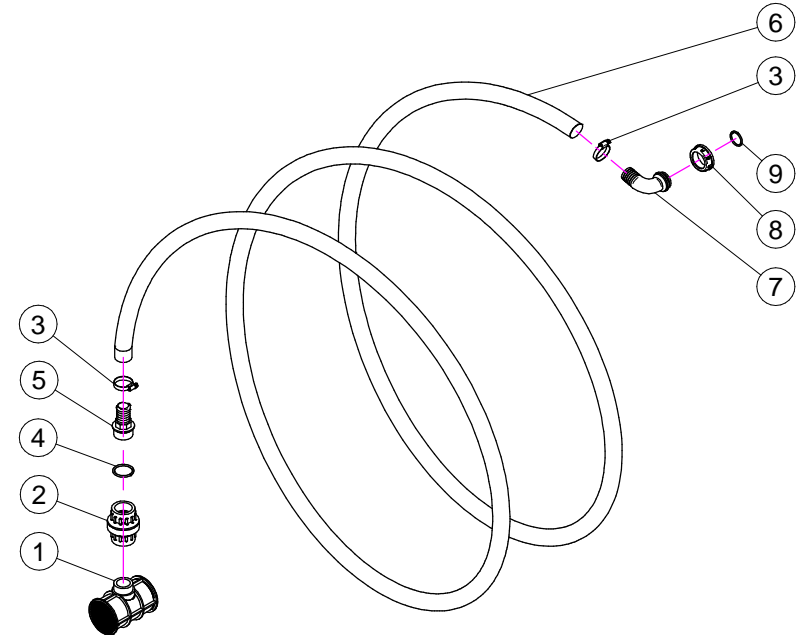
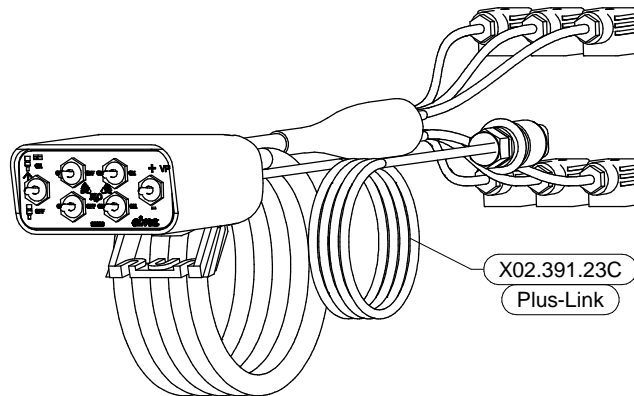
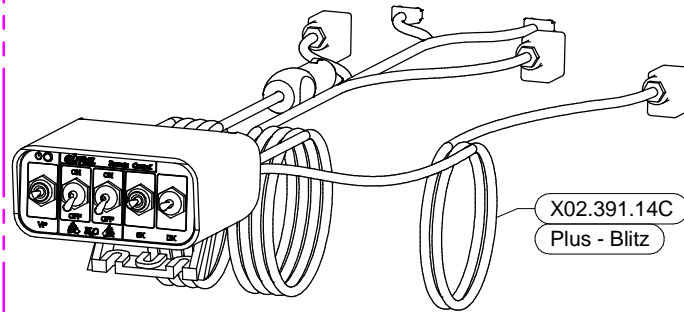
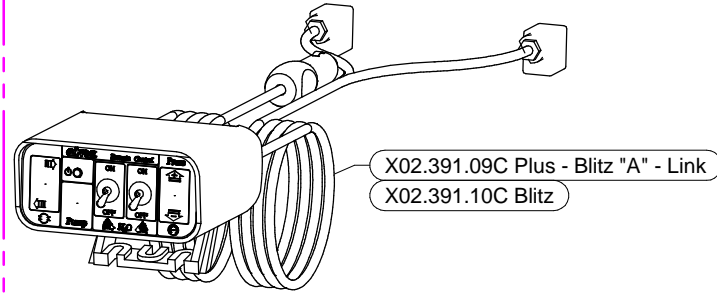
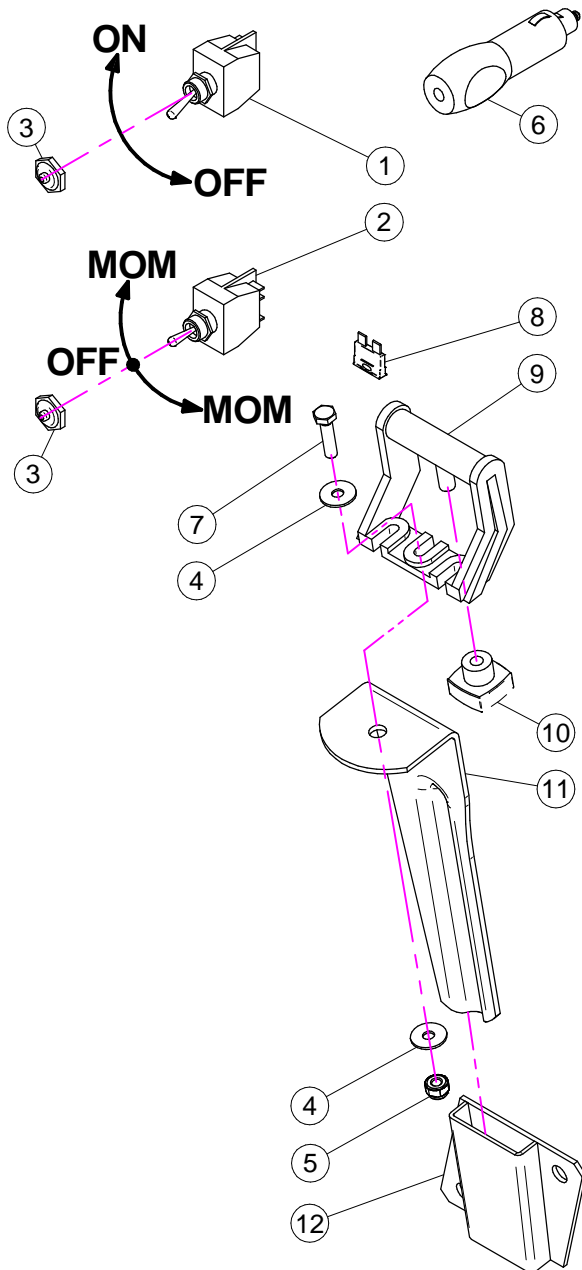

X02.391.09C / 10C / 14C / 23C

N°	Doc. Number	Titolo	Title	Q.tà	Note
1	X21.030.005	DEVIATORE 2V 2P ON-OFF 10A	SWITCH 2V 2P ON-OFF 10A	1	
2	X21.030.006	DEVIATORE MOM - 0 - MOM 10A	SWITCH MOM - 0 - MOM 10A	1	
3	X21.030.007	CAPPUCCIO INTERRUTTORE D.12	SWITCH CAP D.12	2	
4	XRP.006.018	RONDELLA PIANA D. 6x18	WASHER D.6x18	2	
5	XDA.006.0AG	DADO AUTOBLOCCANTE M6 ALTO PG	SELF-LOCKING NUT - HIGH M6	1	
6	X21.030.008	CONNETTORE DI ALIMENTAZIONE 12V	12V POWER JACK	1	
7	XTE.006.025T	VITE TE M6X25	SCREW TE M6X25	1	
8	X21.030.004	FUSIBILE - 10 Ah	10 Ah FUSE	1	
9	X21.030.002	STAFFA DI FISSAGGIO MOBILE	MOVING FIXING BRACKET	1	
10	X21.030.003	POMELLO DI BLOCCAGGIO	FIXING KNOB	1	
11	X20.111.000	STAFFA PORTA BAIONETTA	BRACKET	1	
12	X20.107.000	SUPPORTO A BAIONETTA FEMMINA	FEMALE BAYONET SUPPORT	1	

TUBAZ.RIEMP

N°	Doc. Number	Titolo	Title	Q.tà	Note
1	X00.611.000	FILTRO A T PER TUBAZIONE RIEMPIMENTO	T FILTER	1	
2	X00.300.000	VALVOLA DI FONDO F-F 1" 1/4	FOOT VALVE F-F 1" 1/4	1	
3	XF0.025.040I	FASCETTA A VITE 25/40 W4 INOX	STAINLESS STEEL CLIP	2	
4	XOR.000.144	OR D.39,69x3,53	O-RING D.39,69x3,53	1	
5	X00.423.000	RACCORDO DIRITTO PG 30 FIL.1" 1/4 GAS	MALE CONNECTOR RH 30 1" 1/4 GAS	1	
6	X02.238.450	TUBO SPIRALATO D.30 L=4500	SPIRAL HOSE D.30 L=4500	1	
7	X00.481.000	RACCORDO CURVO P.G. D.30	D.30 HOSETAIL	1	
8	X02.165.000	GIRELLO A FILETTO RAPIDO	RAPID THREAD FLY NUT	1	
9	XOR.000.508	OR D.30 x 3	30 x 3 O-RING GASKET	1	

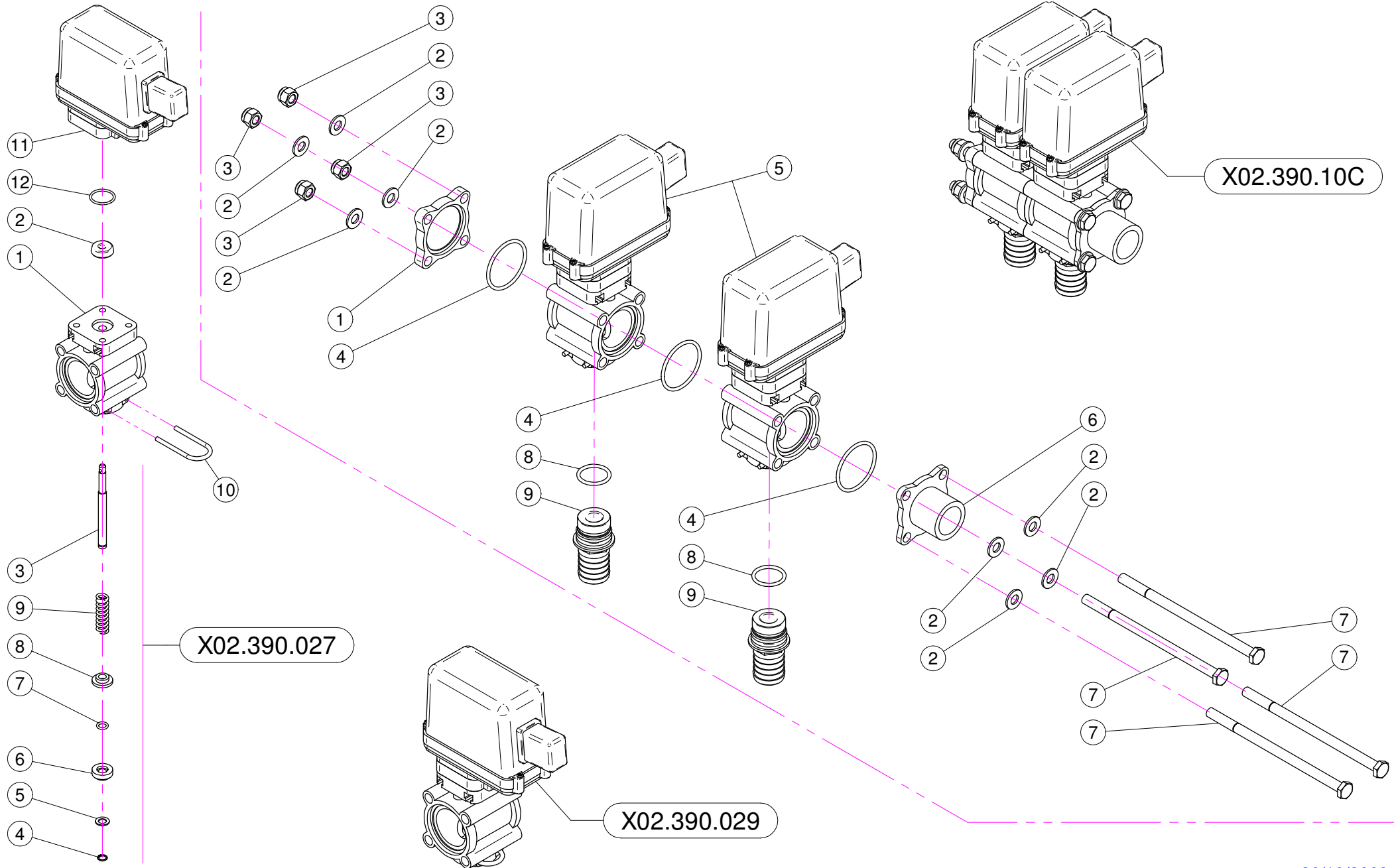

X02.390.029

N°	Doc. Number	Titolo	Title	Q.tà	Note
1	X02.390.007	CORPO VALVOLA	VALVE BODY	1	
2	X02.390.008	GUARNIZIONE D.6x17x6 VITON	GASKET	1	
3	X02.390.020	PERNO VALVOLA MANUALE INOX	PIN	1	
4	X02.390.013	ANELLO ARRESTO	STOP RING	1	
5	X02.390.014	RONDELLA PIANA 7,2 x 12 INOX	WASHER 7,2 x 12 INOX	1	
6	X02.390.015	PIATTELLO INFERIORE VALVOLA	LOWER PIATTELLO VALVE	1	
7	X02.390.016	OR 6,7 x 1,78	O RING	1	
8	X02.390.009	PIATTELLO SUPERIORE VALVOLE	SUPERIOR PIATTELLO VALVES	1	
9	X02.390.011	MOLLA DI RITEGNO	SPRING	1	
10	X21.130.005	FORCHETTA PER RUB. MAN. SEMP. PR	FORK	1	
11	X02.390.028	ELETTROVALVOLA COMPLETA ARAG BLU	SOLENOID VALVE	1	
12	XOR.002.075	OR D.18.77 X 1.78	D.18.77 X 1.78 O-RING	1	

X02.390.10C

N°	Doc. Number	Titolo	Title	Q.tà	Note
1	X02.390.017	FLANGIA VALVOLE	VALVE FLANGE	1	
2	XRP.008.000	RONDELLA PIANA D.8	WASHER D.8	8	
3	XDA.008.0AG	DADO AUTOBLOCCANTE M8	SELF LOCKING NUT M8	4	
4	XOR.003.156	OR D.39,34x2,62	O-RING GASKET 39,34x2,62	3	
5	X02.390.029	ELETTROVALVOLA COMPLETA ARAG BLU	SOLENOID VALVE	2	
6	X02.390.018	RACCORDO FLANGIATO 1" GAS	CONNECTOR	1	
7	XTE.008.150	VITE TE M8x150	SCREW TE M8 x 150	4	
8	XOR.000.130	OR D.22,22 x 2,62	22,22 x 2,62 O-RING GASKET	2	
9	X20.094.000	PORTAGOMMA D.25 ATT.RAP. PER ELETT.	HOSETAIL D.25	2	

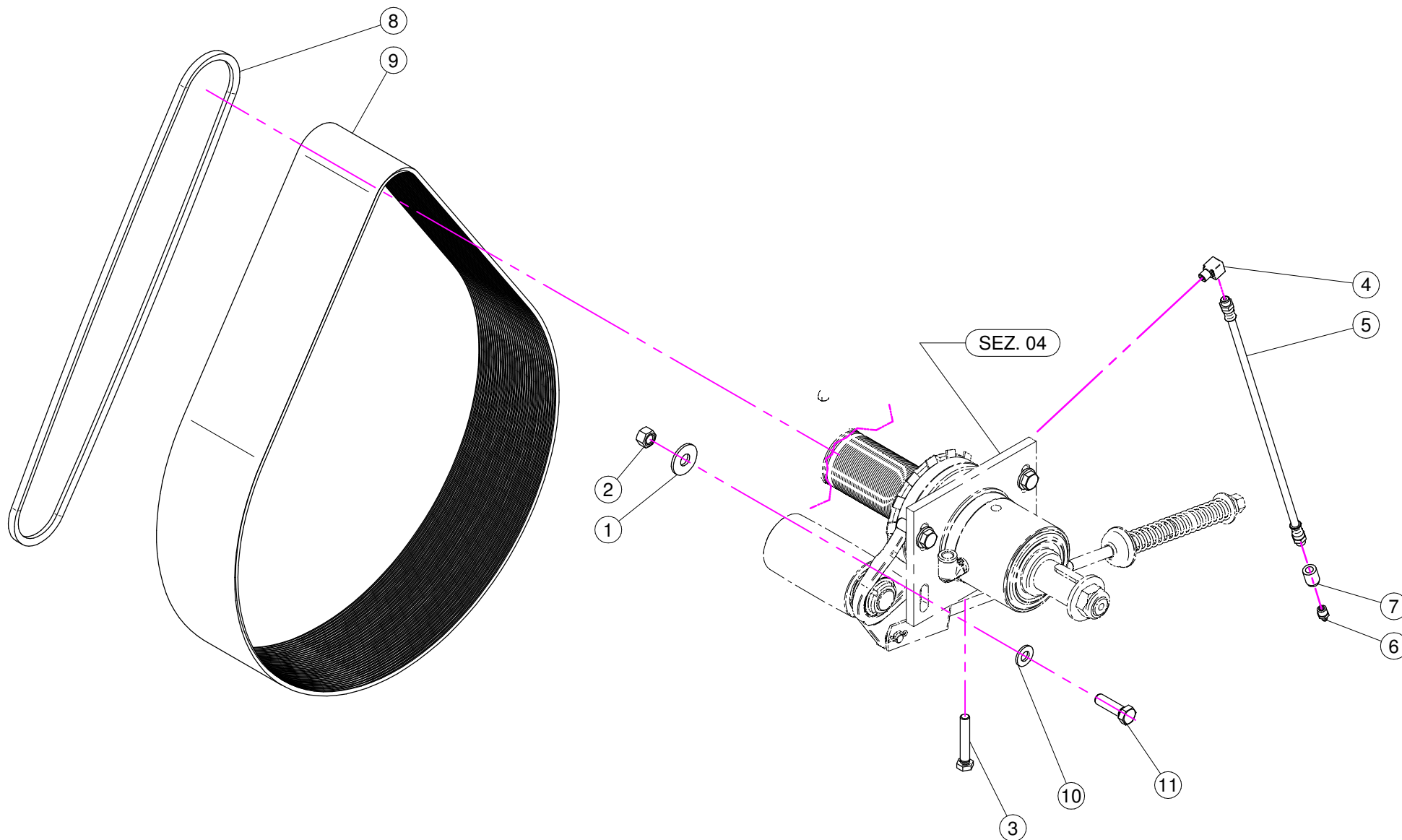

N°	Doc. Number	Titolo	Title	Q.tà	Note
1	XRP.012.036	RONDELLA PIANA D12 X 36	WASHER D12 X 36	4	
2	XD0.12.5587G	DADO M12 PG UNI 5587	M12 NUT	4	
3	XTE.010.060T	VITE TE M10 x 60	SCREW TE M10 x 60	1	
4	X02.736.000	RACCORDO INGRASSAGGIO 90 G. M10 X1	90 G. M10 X1 FITTING	1	
5	X02.738.040	PROLUNGA FLESSIBILE M10 x 1 L= 400	GREASER EXTENSION M10 x 1 L= 400	1	
6	XID.010.001	INGRASSATORE DIRITTO M10X1	GREASE NIPPLE	1	
7	X02.737.000	BOCCOLA PER INGRASSATORE	ACCESSORI	1	
8	XC0.500.03V	CINGHIA TRAPEZOIDALE	V - BELT	2	
9	XC0.690.J50	CINGHIA POLY-V	POLY-V BELT	1	
10	XRP.012.000	RONDELLA PIANA D. 12	WASHER D. 12	1-(2)	
11	XTE.012.040T	VITE TE M12X40 UNI 5739	BOLT TE M12X40	4	

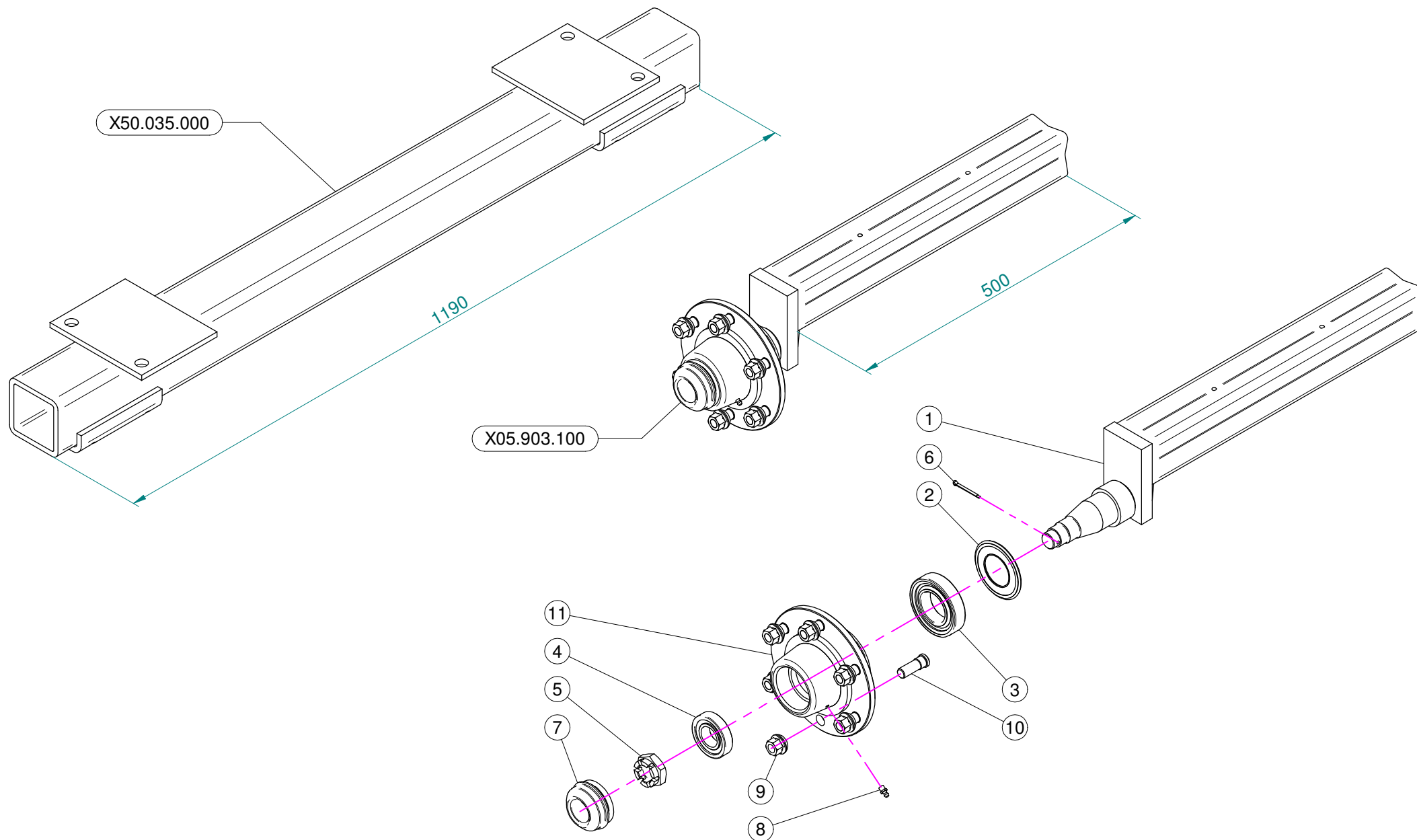

N°	Doc. Number	Titolo	Title	Q.tà	Note
1	X05.971.101	SEMIASSE A 6 COLONNETTE	AXLE SHAFT	1	N.D.
2	X20.258.000	PARA-OLIO 45x85 IN GOMMA	OIL COVER	1	
3	XK0.030.209	CUSCINETTO A UNA CORONA DI RULLI CONICI	BEARING	1	
4	XK0.030.206	CUSCINETTO A UNA CORONA DI RULLI CONICI	BEARING	1	
5	XDI.027.5594F	DADO ESAGONALE A 6 INTAGLI	SIX CASTLE NUT M27	1	
6	X20.259.000	COPIGLIA D.4 L=45 PER MOZZI	SPLIT PIN	1	
7	X04.062.001	COPERCHIETTO DI CHIUSURA	COVER	1	
8	XID.006.001	INGRASSATORE DIRITTO M6	GREASER	1	
9	X05.911.000	DADO PER COLONNETTA M14x1.5	SPECIAL NUT	6	
10	X05.911.001	COLONNETTA PER SEMIASSE M14x1.5	STUD	6	
11	X05.903.001	MOZZI A 6 FORI GEARMORE	SIX HOLES FLANGE	1	N.D.

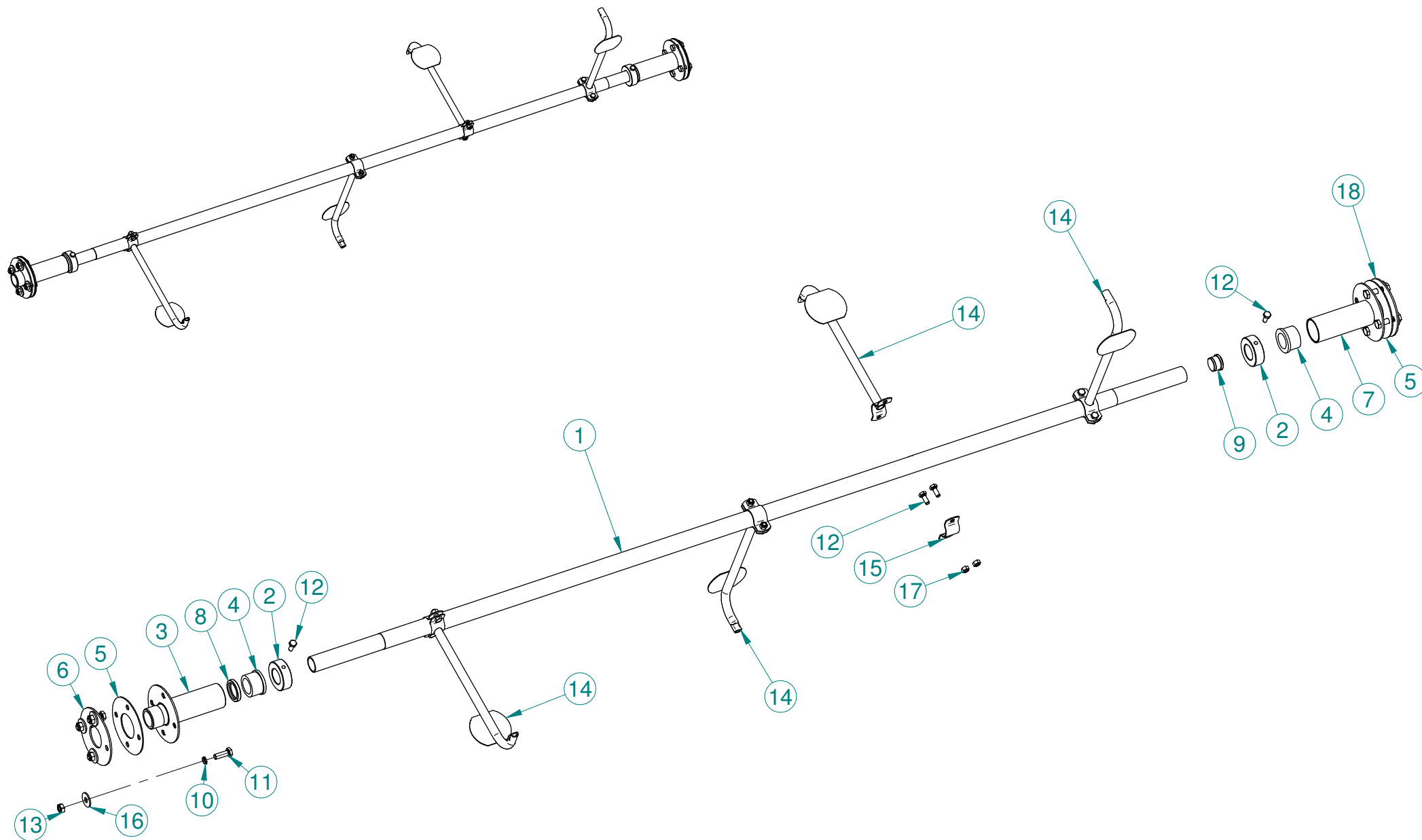

N°	Document	Titolo	Title	Qtà
1	X50.050.000	ALBERO AGITATORE IDRAULICO	HYDRAULIC AGITATOR SHAFT	1
2	X50.052.100	BOCCOLA FERMO AGITATORE	LOCK BUSH	2
3*	X50.044.050	SUPPORTO ANTERIORE AGITATORE IDRAULICO	FRONT STEEL SUPPORT	1
4	X50.046.000	BOCCOLA IN TEFLON PER ALBERO	SHAFT TEFLON BUSH	2
5	X50.048.050	GUARNIZIONE AGITATORE IDRAULICO	GASKET	2
6	X50.047.050	FLANGIA ANT. ESTERNA AGITATORE IDRAULICO	EXTERNAL FIXING ANTERIOR FLANGE	1
7*	X50.045.050	SUPPORTO POSTERIORE PER AGITATORE IDR.	THE POSTERIOR STEEL SUPPORT	1
8	XBA.32.45.07	ANELLO DI TENUTA 32x45x07	32x45x7 SEALING RING	1
9	X50.107.000	TAPPO ALBERO AGITATORE	CAP FOR SHAFT	1
10	XOR.000.112	OR D.9.92 X 2.62	D.9.92 X 2.62 O-RING GASKET	8
11	XTE.010.030I	VITE TE M10X30 INOX	INOX M10X30 SCREW	8
12	XTE.008.025I	VITE TE 8X25 INOX	INOX 8X25 SCREW	10
13	XDOT.10.5587	DADO OTTONE M10	M10 BRASS NUT	8
14	X50.055.200	PALA PER AGITATORE IDRAULICO L=280	AGITATOR BLADE	4
15	X50.053.000	CAVALLOTTO FISSAGGIO PALE AGITATORE	BRACKET	4
16	XRP.010.030	RONDELLA PIANA D.10 x 30 mm	WASHER D.10 x 30 mm	8
17	XDOT.08.5587	DADO IN OTTONE M8	M8 BRASS NUT	8
18	X50.051.050	FLANGIA POST. ESTERNA AGITATORE IDRAULICO	FIXING POSTERIOR FLANGE	1

Gli esplosi elencati di seguito, sono relativi
a varianti od accessori a richiesta

Exploded drawings here listed, concern
variations or demanded accessories

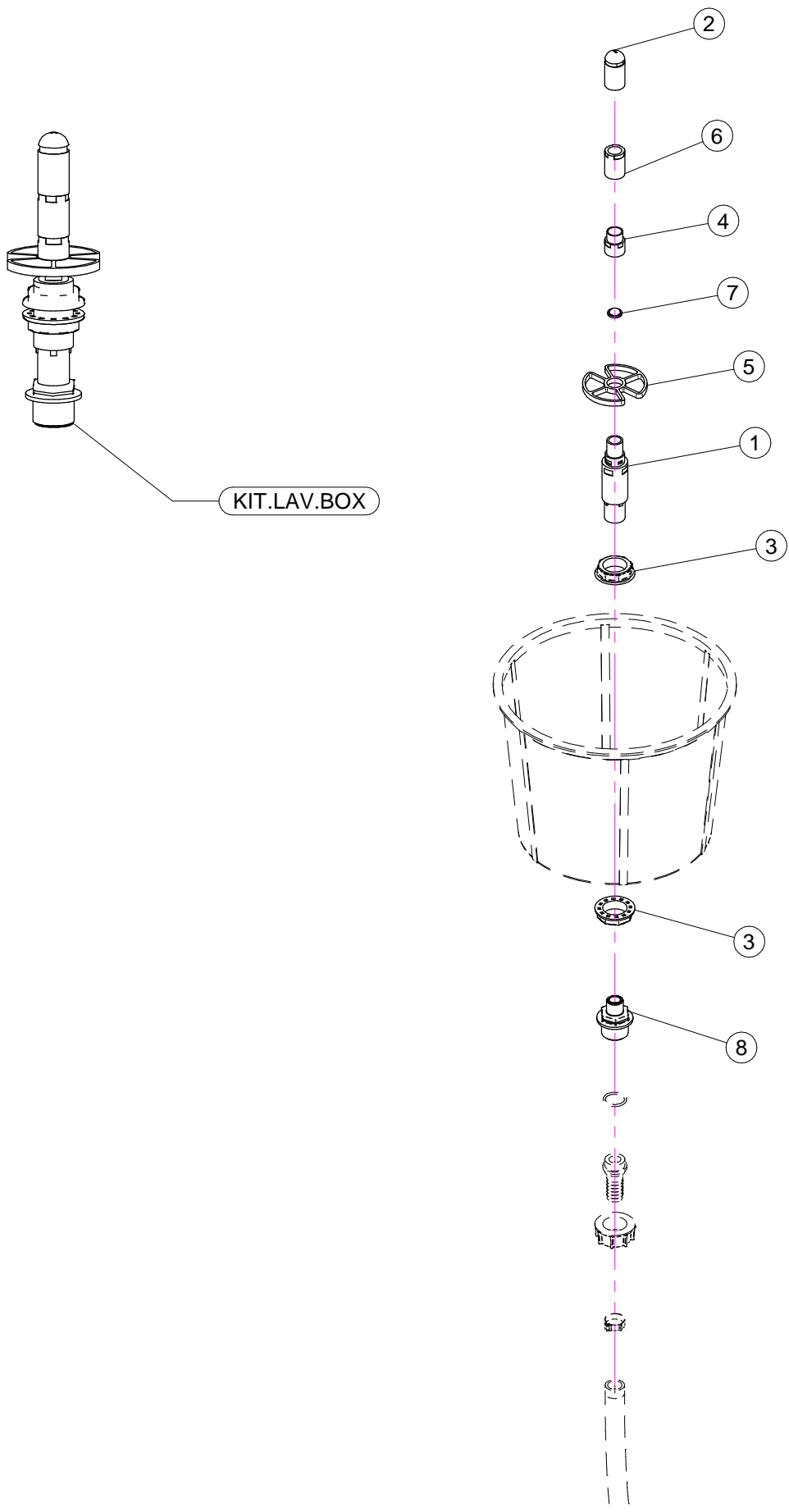

N°	Doc. Number	Titolo	Title	Q.tà	Note
1	X21.190.000	VALVOLA PER TESTINA LAVAGGIO CONTENITORI	VALVE FOR BOX WASH HEAD	1	
2	X21.191.000	TESTINA PER LAVAGGIO CONTENITORI	HEAD FOR BOX WASH	1	
3	X00.542.000	GHIERA 1"	NUT 1"	2	
4	X21.414.000	PORTAFILTRO	FILTER RING	1	
5	X21.411.000	FERMO BARATTOLO	BOX BLOCK	1	
6	X21.412.000	PORTA TESTINA PER LAVAGGIO CONTENITORI	HEAD BASE FOR BOX WASH	1	
7	X21.413.000	FILTRO PER LAVABARATTOLO	FILTER	1	
8	X21.410.000	NIPPLO 1/2M - 1M	NIPPLE 1/2M - 1M	1	

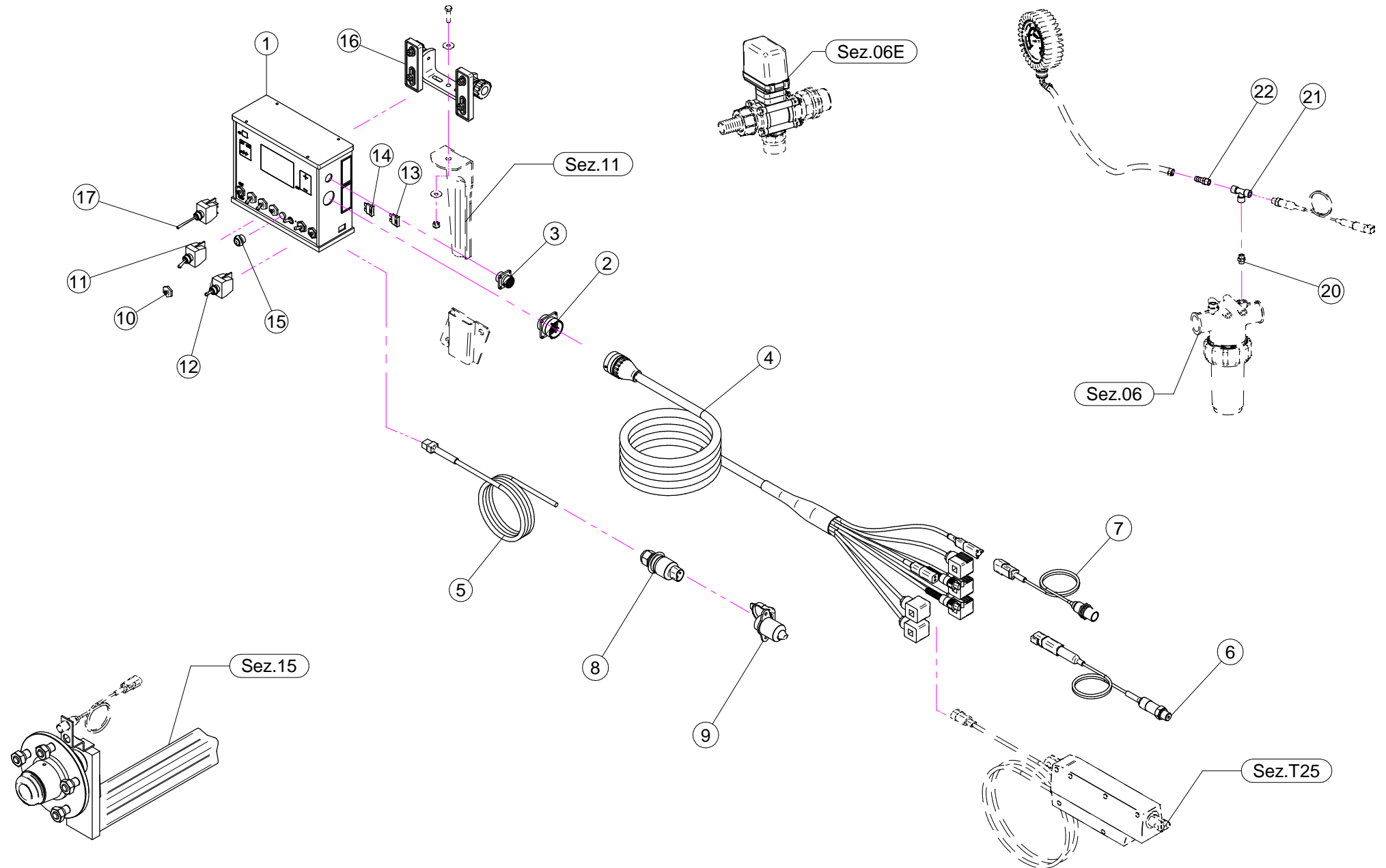

N°	Doc. Number	Titolo	Title	Q.tà	Note
1	X21.138.200	COMPUTER SERIE 844 AB	COMPUTER SERIES 844 AB	1	
2	X21.166.000	CONNETTORE BURNDY 28 PIN	BURNDY 28 PIN CONNECTOR	1	
3	X21.167.000	CONNETTORE BURNDY 8 PIN	BURNDY 8 PIN CONNECTOR	1	
4	X21.143.100	CAVO DATI COMPUTER 4VP+2AT-SP	COMPUTER DATA CABLE 4VP+2AT-SP	1	
5	X21.161.000	CAVO DI ALIMENTAZIONE COMPUTER	COMPUTER POWER WIRE	1	
6	X21.140.000	TRASDUTTORE DI PRESSIONE 0-10 BAR	PRESSURE TRANSDUCER	1	
7	X21.139.000	SENSORE DI VELOCITA' CL5X	SPEED SENSOR	1	
8	X21.162.000	SPINA DI ALIMENTAZIONE CAVO TRIPOLARE	POWER PLUG	1	
9	X21.163.000	PRESA DI ALIMENTAZIONE TRIPOLARE	POWER PLUG	1	
10	X21.030.007	CAPPUCCIO INTERRUTTORE D.12	SWITCH CAP D.12	7	
11	X21.030.005	DEVIATORE 2V 2P ON-OFF 10A	SWITCH 2V 2P ON-OFF 10A	5	
12	X21.030.006	DEVIATORE MOM - 0 - MOM 10A	SWITCH MOM - 0 - MOM 10A	1	
13	X21.030.004	FUSIBILE - 10 Ah	10 Ah FUSE	1	
14	X21.168.000	FUSIBILE - 5 Ah	5 Ah FUSE	1	
15	X21.170.000	INTERRUTTORE PULSANTE 2V 2P ON - OFF	PUSH-BUTTON SWITCH 2V 2P ON - OFF	1	
16	X21.165.000	STAFFA DI FISSAGGIO	BRACKET	1	
17	X21.030.018	DEVIATORE LUNGO 2V 2P ON-OFF 10A	LONG SWITCH 2V 2P ON-OFF 10A	1	

N°	Doc. Number	Titolo	Title	Q.tà	Note
20	X24.004.000	NIPPLO M/M 1/4"	NIPLES M/M 1/4"	1	
21	X21.172.000	RACCORDO A T 1/4" F/F/F	T FITTING 1/4" F/F/F	1	
22	X00.414.000	PORTAGOMMA D.11 1/4" M. FORATO	STRAIGHT HOSE D.11 1/4"	1	

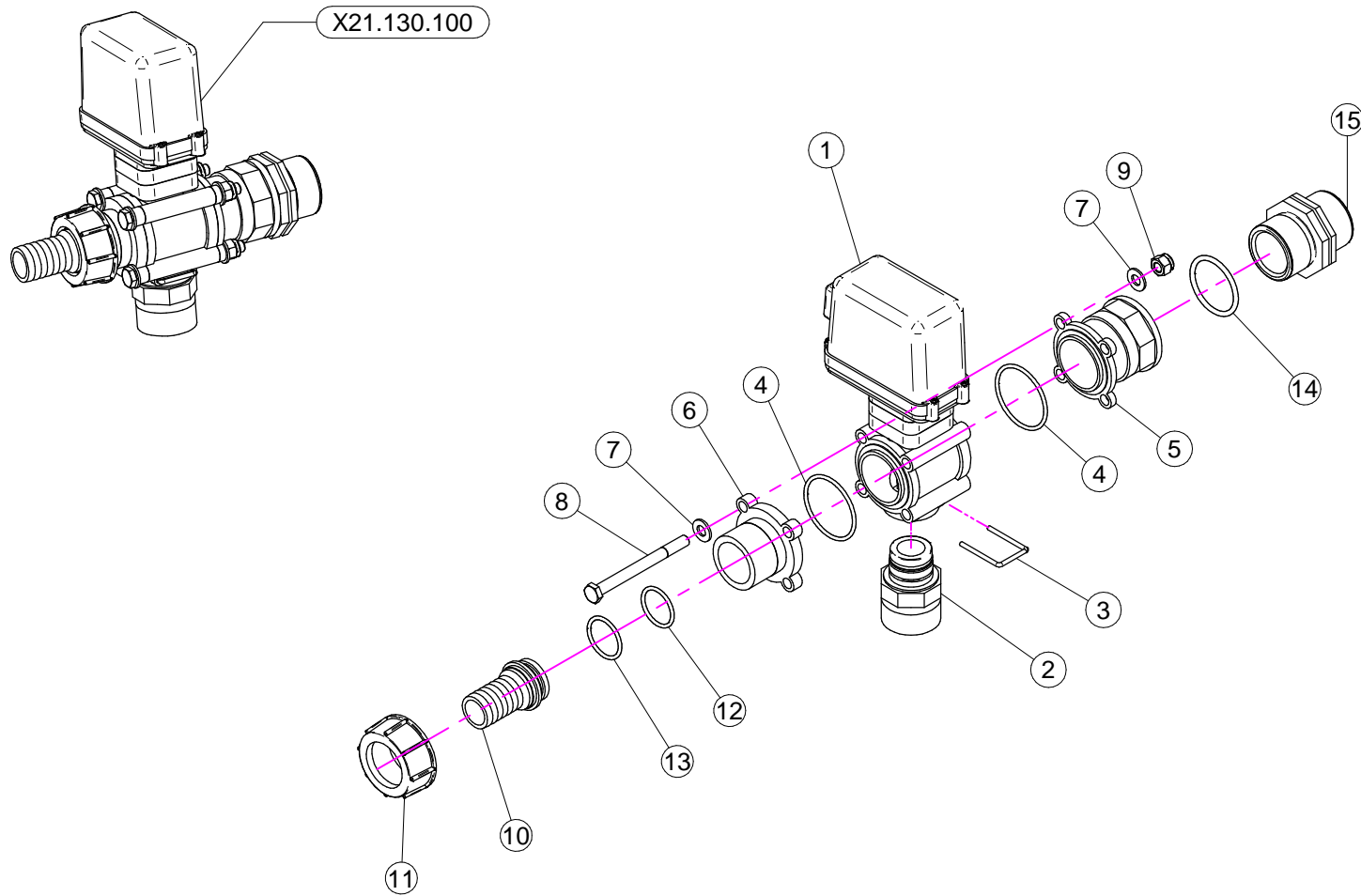

N°	Doc. Number	Titolo	Title	Q.tà	Note
1	X21.130.100	VALVOLA DI REGOLAZIONE PROPORZIONALE ELETTRICA VELOCE	QUICK ELECTRIC PROPORTIONAL VALVE	1	
2	X21.131.000	RIDUZIONE ATT.RAP. G 1" 1/4	REDUCTION J. F. G 1" 1/4	1	
3	X21.130.005	FORCHETTA ATTACCO RAPIDO	FORK FASTNER JOINT	1	
4	XOR.003.181	OR D. 45,69x50,93x2,62	45,69x50,93x2,62 O-RING	2	
5	X21.133.000	RACCORDO FLANGIATO 1" - 1 1/4"	CONNECTOR	1	
6	X21.132.000	FLANGIA VALVOLE	VALVE FLANGE	1	
7	XRP.008.000	RONDELLA PIANA D.8	WASHER D.8	8	
8	XTE.008.090	VITE TE M8 x 90	SCREW TE M8 x 90	4	
9	XDA.008.0AG	DADO AUTOBLOCCANTE M8	SELF LOCKING NUT M8	4	
10	X02.363.000	RACCORDO DIRITTO PG D.25 - 1 1/4	STRAIGHT HOSE R.H D.25 - 1 1/4	1	
11	X00.058.006	GIRELLO 1" 1/4 GAS	1" 1/4 FLY NUT	1	
12	XOR.003.106	OR D.26.65x2.62	O-RING D.26.65x2.62	1	
13	XOR.003.112	OR D.28,24x2,62	O-RING D.28,24x2,62	1	
14	XOR.000.144	OR D.39,69x3,53	O-RING D.39,69x3,53	1	
15	X00.345.010	NIPPLO 1" 1/4 + 1" 1/4 GAS	NIPPLE 1" 1/4 + 1" 1/4 GAS	1	

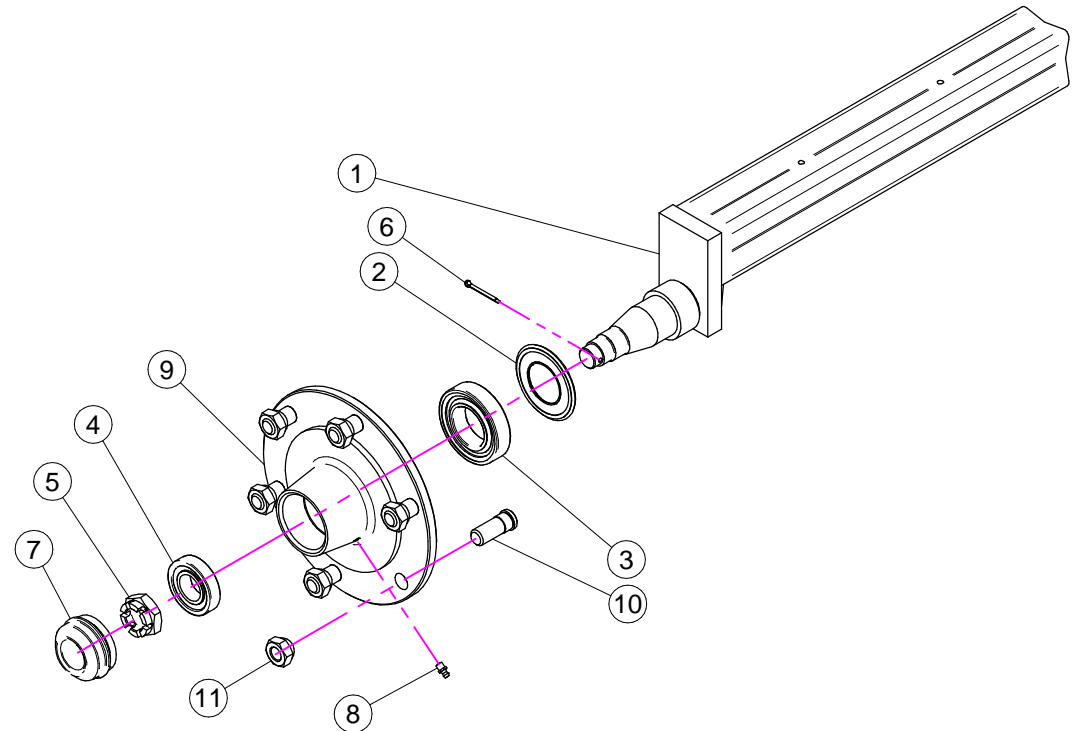
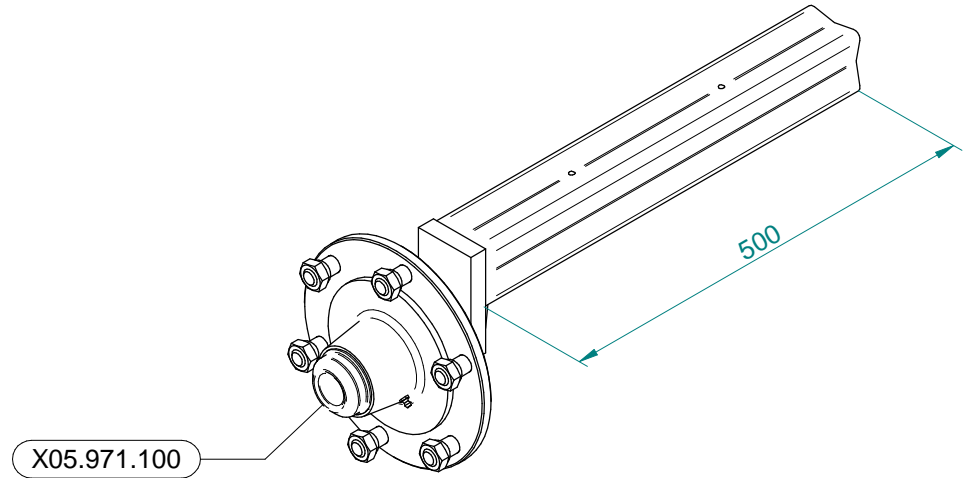
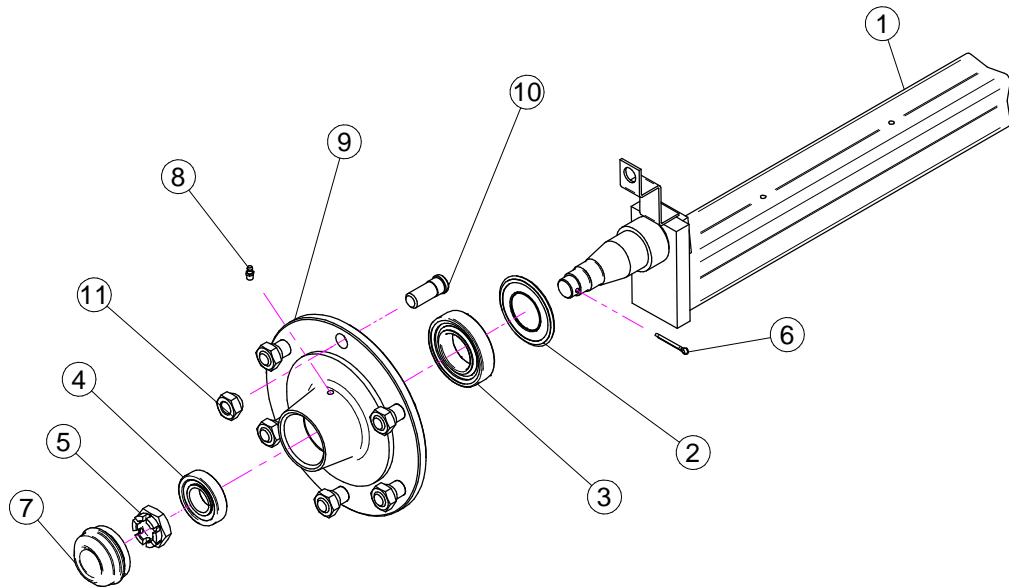
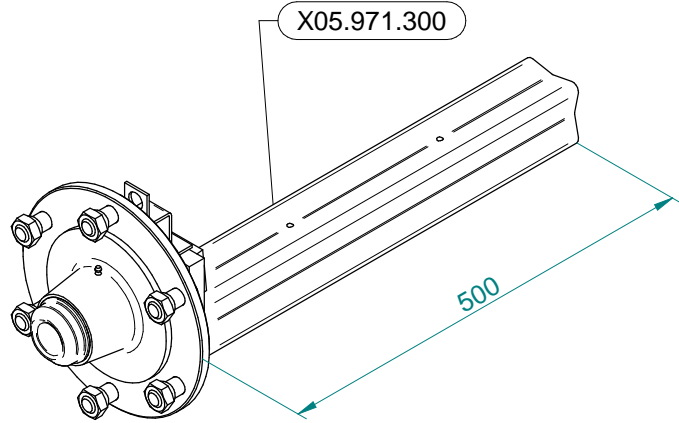

X05.971.300

N°	Doc. Number	Titolo	Title	Q.tà
1	X05.971.301	SEMIASSE A 6 COLONNETTE	AXLE SHAFT	1
2	X20.258.000	PARA-OLIO 45x85 IN GOMMA	OIL COVER	1
3	XK0.030.209	CUSCINETTO A UNA CORONA DI RULLI CONICI 30209	BEARING	1
4	XK0.030.206	CUSCINETTO A UNA CORONA DI RULLI CONICI 30206	BEARING	1
5	XDI.027.5594F	DADO ESAGONALE A 6 INTAGLI	SIX CASTLE NUT M27	1
6	X20.259.000	COPIGLIA D.4 L=45 PER MOZZI	SPLIT PIN	1
7	X04.062.001	COPERCHIETTO DI CHIUSURA	COVER	1
8	XID.006.001	INGRASSATORE DIRITTO M6	GREASER	1
9	X04.691.002	FLANGIA MOZZI A 6 FORI	SIX HOLES FLANGE	1
10	X04.697.001	COLONNETTA PER SEMIASSE M18x1.5	STUD	6
11	X04.697.000	DADO PER COLONNETTA M18x1.5	SPECIAL NUT	6

X05.971.100

N°	Doc. Number	Titolo	Title	Q.tà	Note
1	X05.971.101	SEMIASSE A 6 COLONNETTE	AXLE SHAFT	1	N.D.
2	X20.258.000	PARA-OLIO 45x85 IN GOMMA	OIL COVER	1	
3	XK0.030.209	CUSCINETTO A UNA CORONA DI RULLI CONICI 30209	BEARING	1	
4	XK0.030.206	CUSCINETTO A UNA CORONA DI RULLI CONICI 30206	BEARING	1	
5	XDI.027.5594F	DADO ESAGONALE A 6 INTAGLI	SIX CASTLE NUT M27	1	
6	X20.259.000	COPIGLIA D.4 L=45 PER MOZZI	SPLIT PIN	1	
7	X04.062.001	COPERCHIETTO DI CHIUSURA	COVER	1	
8	XID.006.001	INGRASSATORE DIRITTO M6	GREASER	1	
9	X04.691.002	FLANGIA MOZZI A 6 FORI	SIX HOLES FLANGE	1	N.D.
10	X04.697.001	COLONNETTA PER SEMIASSE M18x1.5	STUD	6	
11	X04.697.000	DADO PER COLONNETTA M18x1.5	SPECIAL NUT	6	

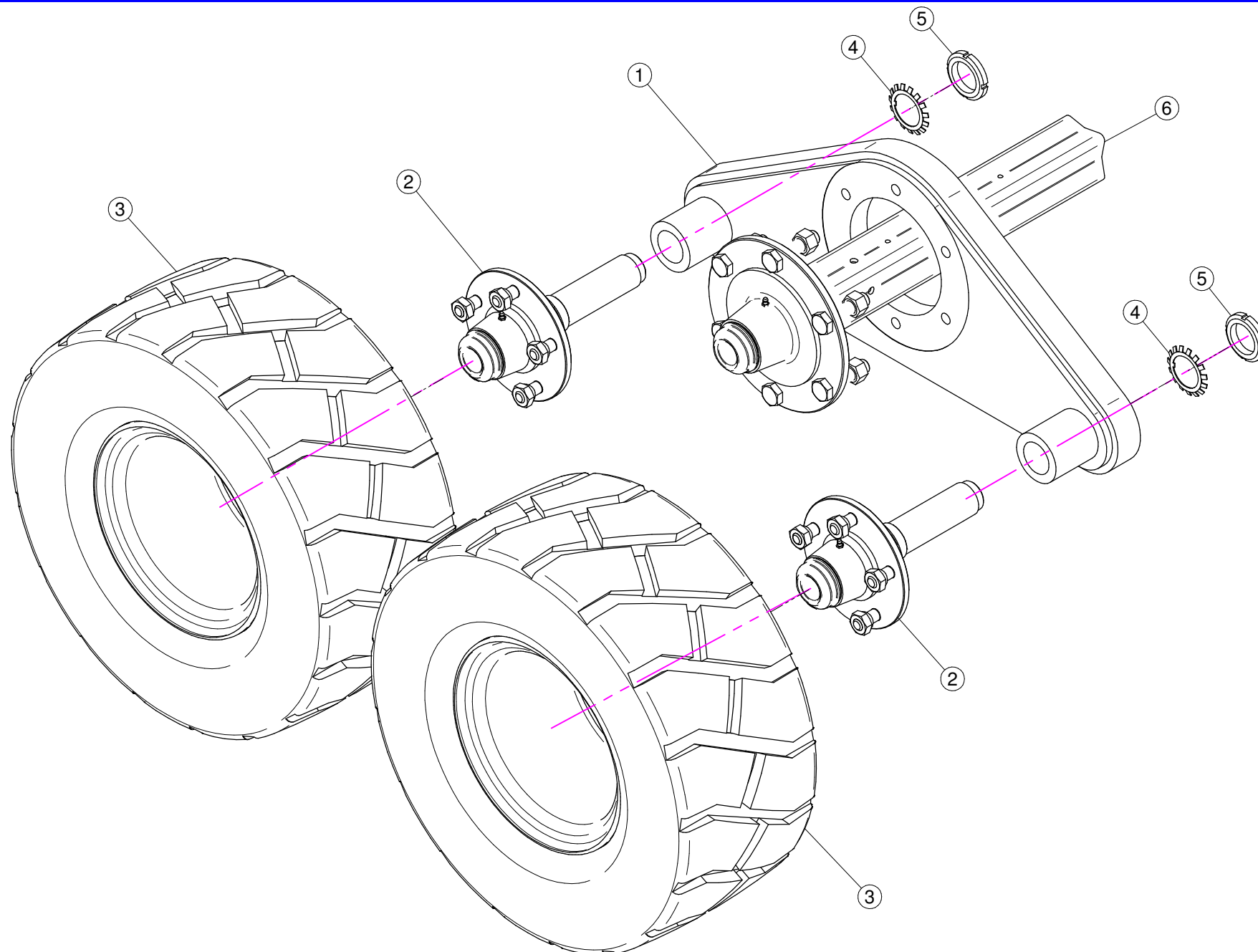

N°	Doc. Number	Titolo	Title	Q.tà	Note
1	X40.369.100	PIASTRA PORTA MOZZI RUOTE TANDEM	HUB SUPPORT SHEET	2	
2	X04.683.430	MOZZO A 5 COLONNETTE	WHEEL HUB	4	
3	X50.350.000	RUOTA 23x9x10 18PR	WHEELS AND TIRES	4	
4	XMB.009.000	ROSETTA DI SICUREZZA D.45	TOOTH LOCK WASHER	4	
5	XKM.009.000	GHIERA KM9	NUT KM9	4	
6	X05.971.400	ASSIEME MOZZO 6 COLONNETTE	HUB	1	

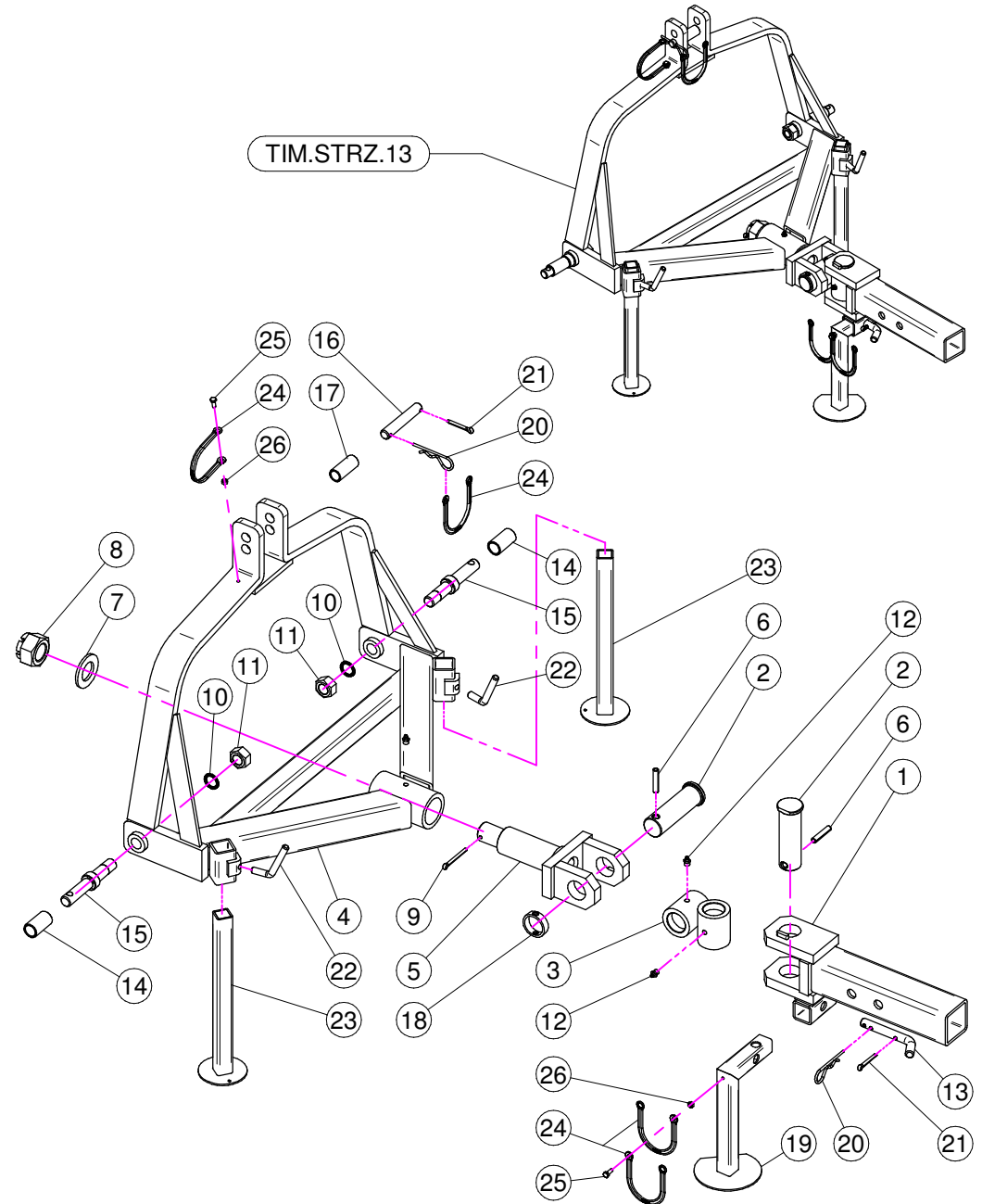
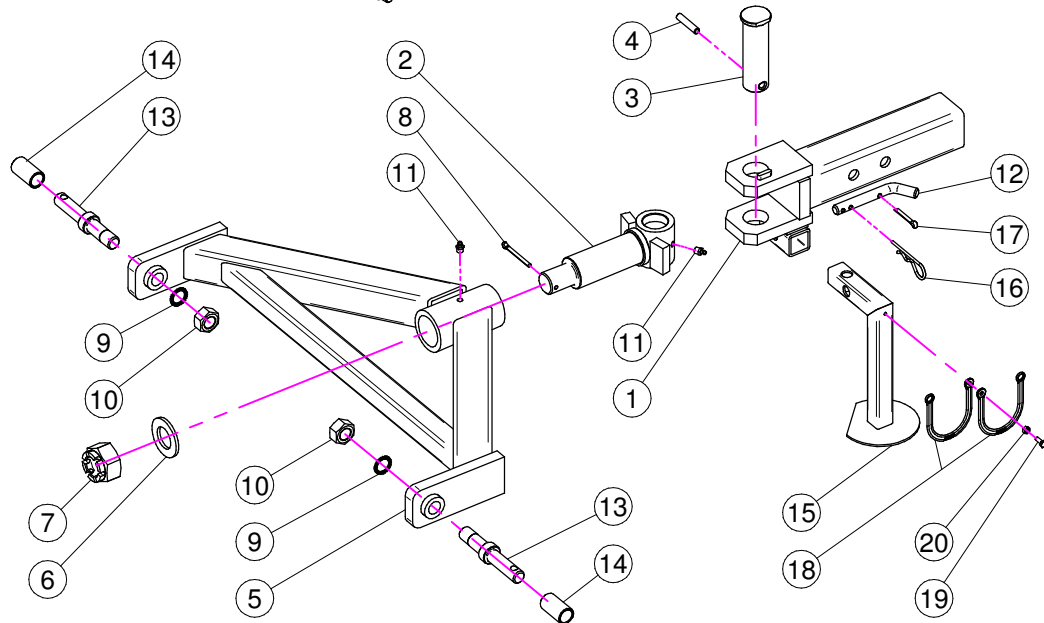
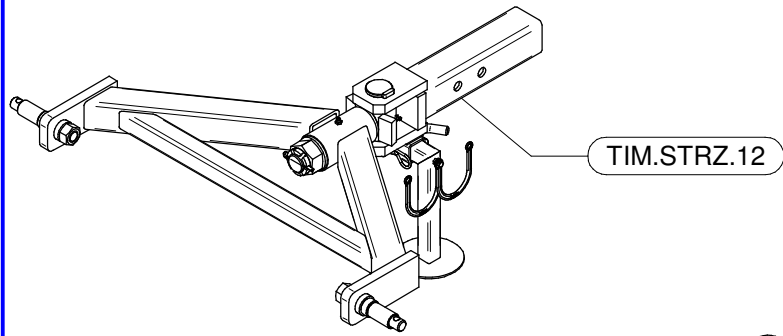
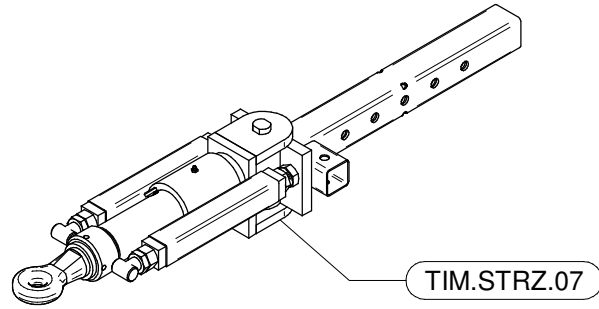

TIM.STRZ.12

N°	Doc. Number	Titolo	Title	Q.tà	Note
1	X40.153.201	TIMONE SNODATO - PARTICOLARE FISSO	DRAW-BAR - FIXING PARTICULAR	1	
2	X40.154.100	PERNO TIMONE STERZANTE A 2 PUNTI	PIN	1	
3	X40.150.000	PERNO PER TIMONE STERZANTE	PIN	1	
4	XSE.010.050	SPINA ELASTICA 10 x 50	SPRING PIN	1	
5	X40.152.000	CORPO A 2 PUNTI PER TIMONE STERZANTE	2 POINTS BODY	1	
6	XRP.036.000	RONDELLA PIANA Ø36	WASHER	1	
7	XDI.036.5593F	DADO AD INTAGLI M36	CASTLE NUT M30	1	
8	XCP.006.070	COPIGLIA	SPLIT PIN	1	
9	XRD.022.000	RONDELLA DENTELLATA D.22	TAB WASHER D.22	2	
10	XD0.22.5588F	DADO M22 x 1.5	NUT M22 x 1.5	2	
11	XID.010.001	INGRASSATORE DIRITTO M10X1	GREASE NIPPLE	2	
12	X20.505.000	SPINOTTO PIEDE D' APPOGGIO	PIN JACK STAND	1	
13	X04.064.100	SPINOTTO SOLLEVATORE	PIN POWER LIFT	2	
14	X40.202.000	BOCCOLA PER SPINOTTI SOLLEVATORE	BUSH	2	
15	X40.342.000	PIEDE D'APPOGGIO ESTRAIBILE	EXTRACTABLE JACK STAND	1	
16	X00.100.004	COPIGLIA D.4	SPLIT PIN D.4	1	
17	XCP.006.040I	COPIGLIA D.6 Lg.40	PIN D.6 Lg.40	1	
18	X21.183.000	STRISCIA FERMATAPPI	CAP STOP	2	
19	XTE.006.016T	VITE TE M6X16	SCREW TE M6X16	1	
20	XD0.06.5588G	DADO M6	NUT M6	1	

TIM.STRZ.13

N°	Doc. Number	Titolo	Title	Q.tà	Note
1	X40.153.201	TIMONE SNODATO - PARTICOLARE FISSO	DRAW-BAR - FIXING PARTICULAR	1	
2	X40.150.000	PERNO PER TIMONE STERZANTE	PIN	2	
3	X40.155.000	CROCERA PER TIMONE STERZANTE	JOINT	1	
4	X40.151.000	CORPO A 3 PUNTI PER TIMONE STERZANTE	3 POINTS BODY	1	
5	X40.154.000	PERNO PER TIMONE STERZANTE 3 PUNTI	PIN	1	
6	XSE.010.050	SPINA ELASTICA 10 x 50	SPRING PIN	2	
7	XRP.036.000	RONDELLA PIANA Ø36	WASHER	1	
8	XDI.036.5593F	DADO AD INTAGLI M36	CASTLE NUT M30	1	
9	XCP.006.070	COPIGLIA	SPLIT PIN	1	
10	XRD.022.000	RONDELLA DENTELLATA D.22	TAB WASHER D.22	2	
11	XD0.22.5588F	DADO M22 x 1.5	NUT M22 x 1.5	2	
12	XID.010.001	INGRASSATORE DIRITTO M10X1	GREASE NIPPLE	3	
13	X20.505.000	SPINOTTO PIEDE D' APPOGGIO	PIN JACK STAND	1	
14	X40.202.000	BOCCOLA PER SPINOTTI SOLLEVATORE	BUSH	2	
15	X04.064.100	SPINOTTO SOLLEVATORE	PIN POWER LIFT	2	
16	X04.076.000	SPINOTTO 3° PUNTO	PIN	1	
17	X20.778.000	BOCCOLA PER TERZO PUNTO PER PLUS	BUSH	1	
18	X40.363.000	DISTANZIALE	SPACER	1	
19	X40.342.000	PIEDE D'APPOGGIO ESTRAIBILE	EXTRACTABLE JACK STAND	1	
20	X00.100.004	COPIGLIA D.4	SPLIT PIN D.4	2	
21	XCP.006.040I	COPIGLIA D.6 Lg.40	PIN D.6 Lg.40	2	
22	X02.175.000	MANIGLIA DI BLOCCAGGIO	LOOKING HANDLE	2	
23	X40.251.200	PIEDE D'APPOGGIO	JACK	2	
24	X21.183.000	STRISCIA FERMATAPPI	CAP STOP	4	
25	XTE.006.016T	VITE TE M6X16	SCREW TE M6X16	2	
26	XD0.06.5588G	DADO M6	NUT M6	2	

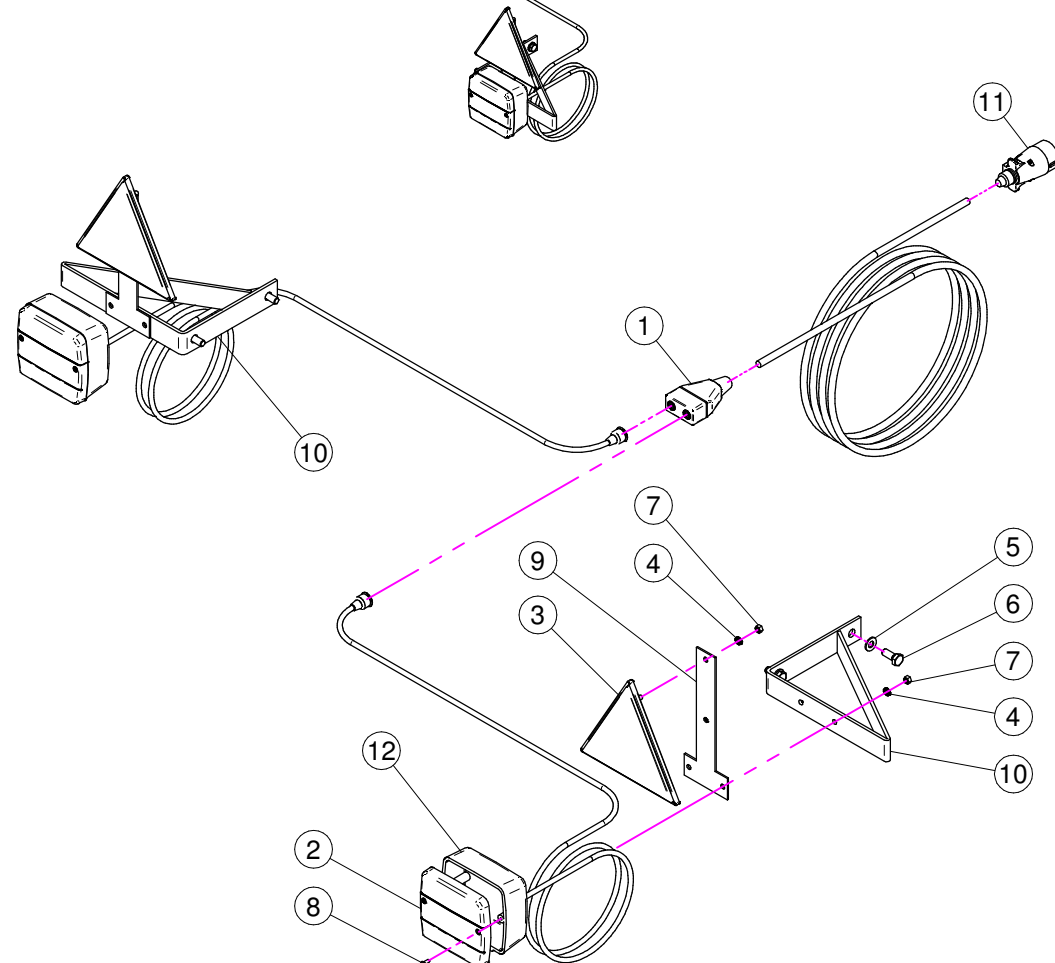
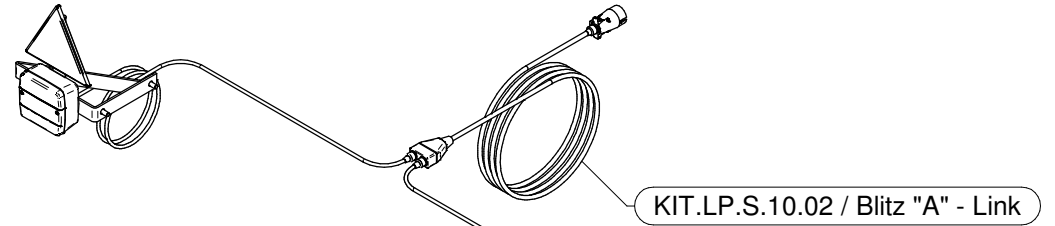
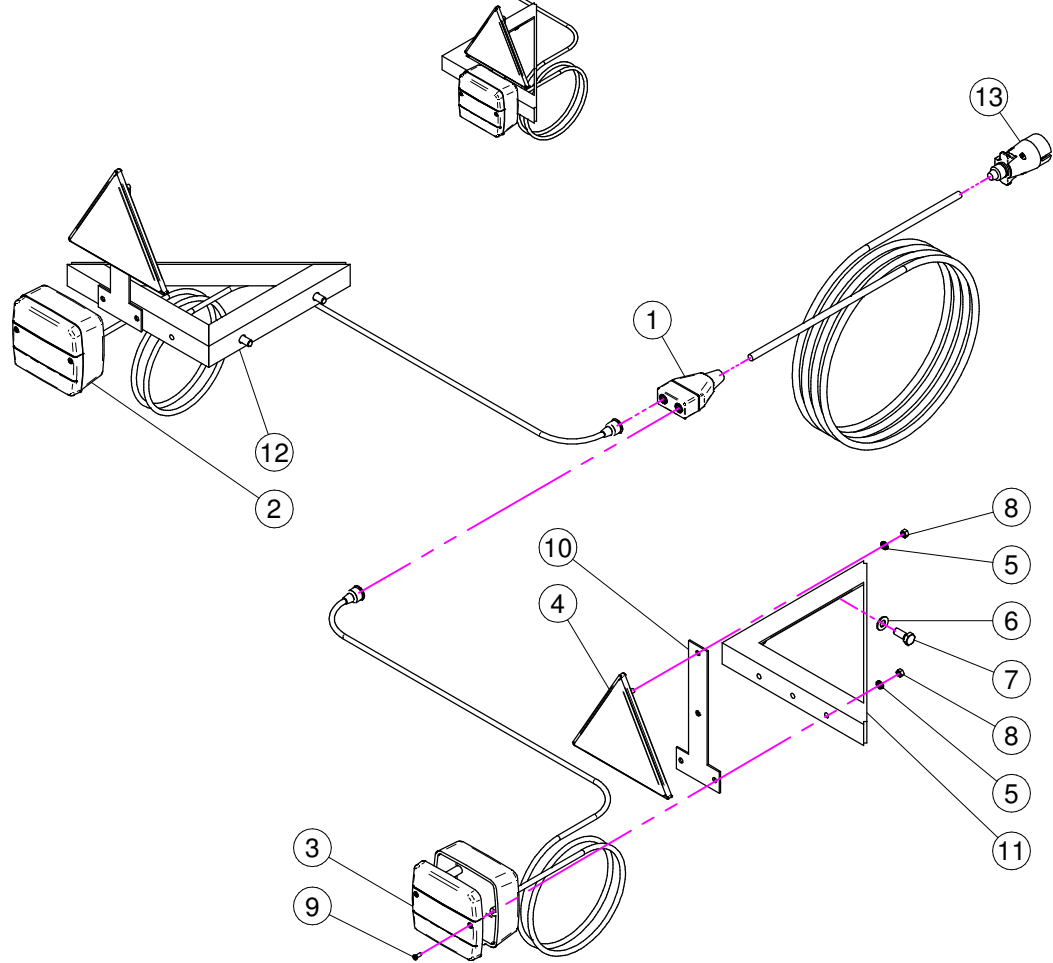
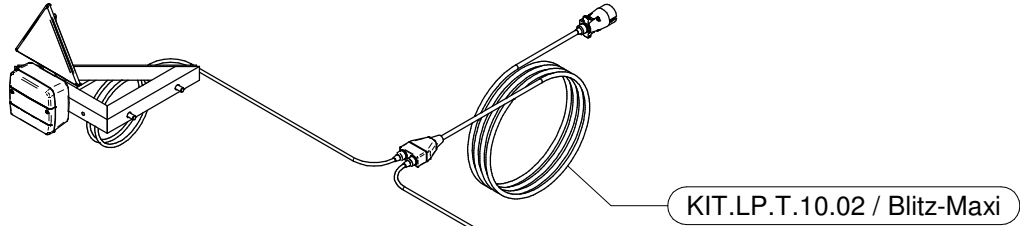

KIT.LP.T.10.02 (BLITZ-MAXI)

N°	Doc. Number	Titolo	Title	Q.tà	Note
1	X24.121.007	SCATOLA BLOCCO DIRAMAZIONI	ELECTRIC BOX	1	
2	X24.121.002	CORPO FANALE POSTERIORE 3F	BODY REAR LIGHT 3L	1	
3	X24.121.004	CATADIOTTRO FANALE POSTERIORE	REAR LIGHT REFLECTOR	2	
4	X24.121.001	CATADIOTTRO TRIANGOLARE	TRIANGULAR REFLECTOR	2	
5	XRD.005.000	RONDELLA DENTELLATA D.5	TAB WASHER D.5	8	
6	XRP.008.000	RONDELLA PIANA D.8	WASHER D.8	4	
7	XTE.008.020T	VITE TE 8x20	SCREW TE 8x20	4	
8	XD0.05.5587G	DADO M5 PG 5587	M5 PG 5587 NUT	8	
9	XTA.03,5.09,5I	VITE AUTOFILETTANTE D.3,5 x 9,5	SELF THREADING D.3,5 x 9,5	4	
10	X40.341.000	STAFFA	BRACKET	2	
11	X40.340.200	STAFFA DX	BRACKET DX	1	
12	X40.340.100	STAFFA SX	BRACKET SX	1	
13	X24.121.006	SPINA	PLUG	1	

KIT.LP.S.10.02 (BLITZ "A" - LINK)

N°	Doc. Number	Titolo	Title	Q.tà	Note
1	X24.121.007	SCATOLA BLOCCO DIRAMAZIONI	ELECTRIC BOX	1	
2	X24.121.004	CATADIOTTRO FANALE POSTERIORE	REAR LIGHT REFLECTOR	2	
3	X24.121.001	CATADIOTTRO TRIANGOLARE	TRIANGULAR REFLECTOR	2	
4	XRD.005.000	RONDELLA DENTELLATA D.5	TAB WASHER D.5	8	
5	XRP.008.000	RONDELLA PIANA D.8	WASHER D.8	4	
6	XTE.008.020T	VITE TE 8x20	SCREW TE 8x20	4	
7	XD0.05.5587G	DADO M5 PG 5587	M5 PG 5587 NUT	8	
8	XTA.03,5.09,5I	VITE AUTOFILETTANTE D.3,5 x 9,5	SELF THREADING D.3,5 x 9,5	4	
9	X40.341.000	STAFFA	BRACKET	2	
10	X40.340.000	STAFFA	BRACKET	2	
11	X24.121.006	SPINA	PLUG	1	
12	X24.121.002	CORPO FANALE POSTERIORE 3F	BODY REAR LIGHT 3L	1	

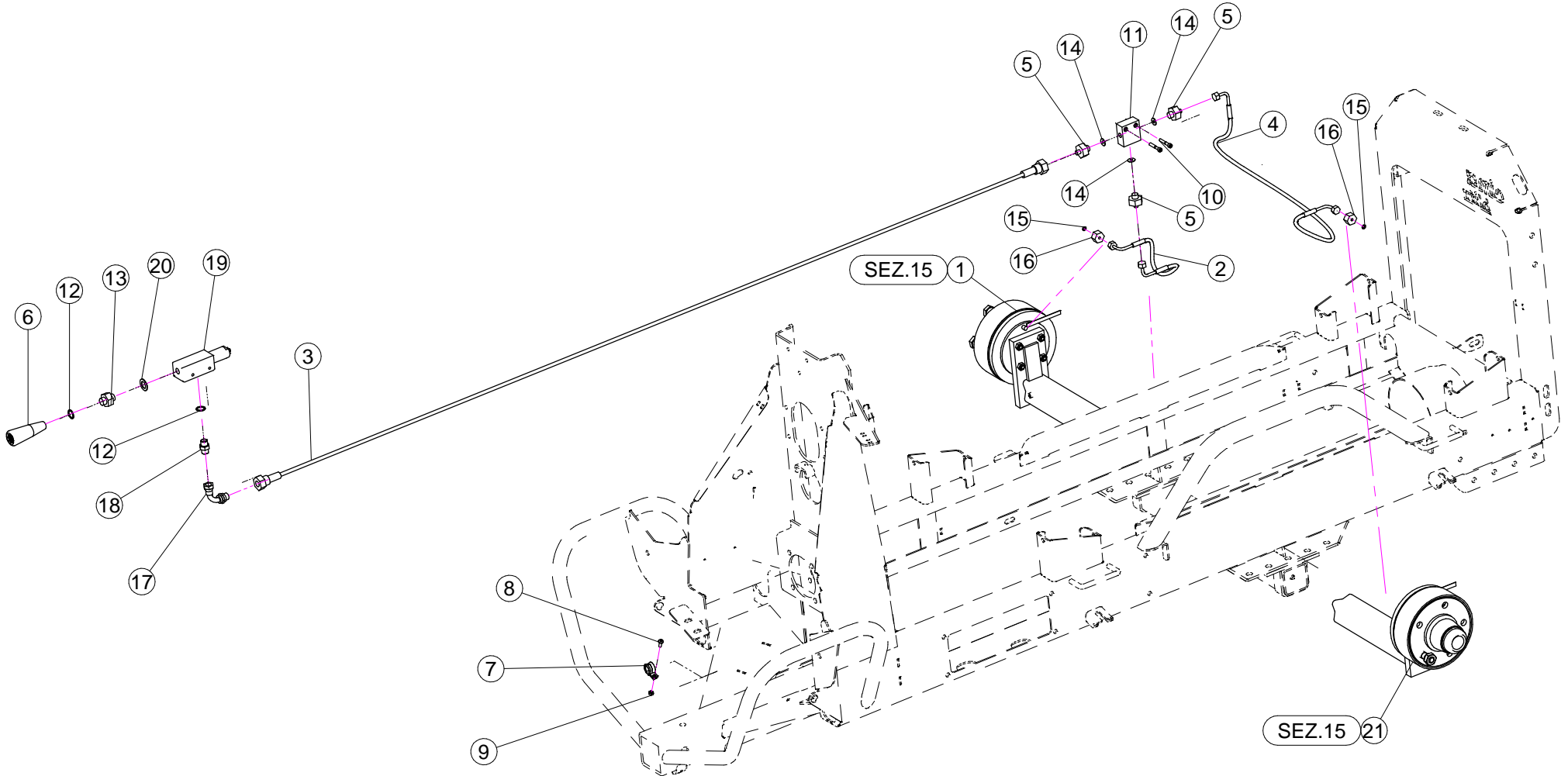

N°	Doc. Number	Titolo	Title	Q.tà
1	X04.683.500	SEMIASSE A 5 COLONNETTE CON FRENO MONTATO SU BLITZ	WHEEL HUB	1
2	X21.341.060	TUBO OLIO 1/4" L=600 CON RACCORDI	OIL HOSE 1/4" L=600 WITH FITTINGS	1
3	X21.341.350	TUBO OLIO 1/4" L=3500 CON RACCORDI	OIL HOSE 1/4" L=3500 WITH FITTINGS	1
4	X21.341.100	TUBO OLIO 1/4" L=1000 CON RACCORDI	OIL HOSE 1/4" L=1000 WITH FITTINGS	1
5	X21.342.000	NIPPLO DOPPIO 1/4" 1/4"	DOUBLE NIPLES 1/4" 1/4"	3
6	X21.343.000	INNESTO FASTER	CLUTCH	1
7	XFG.018.000	FASCETTA GOMMATA PER TUBI D.18	STICKER	1
8	XTCC.06.16	VITE TESTA A CROCE M6x16	CROSS SLOTTED SCREW M6x16	1
9	XDOT.06.5587	DADO OTTONE M6	M6 BRASS NUT 5587	1
10	XTCE.006 .040	VITE BRUGOLA TCE M6x40	BOLT TCE M6x40	2
11	X21.348.000	DISTRIBUTORE OLIO PER FRENO	BRAKE OIL DISTRIBUTOR	1
12	X21.344.000	RONDELLA RAME D.18x1,5	COPPER WASHER D.18x1,5	2
13	X21.345.000	NIPPLO RIDOTTO 3/8 - m18	NIPLES 3/8 - M18	1
14	X21.349.000	RONDELLA RAME D.1/4	COPPER WASHER D.1/4	3
15	X21.346.000	RONDELLA RAME D.10x1,5	COPPER WASHER D.10x1,5	2
16	X21.347.000	RACCORDO RAD 1803	RAD 1803 FITTING	2
17	X21.381.000	CURVA PER OLIO 3/8 M - 3/8 F	OIL BEND 3/8 M - 3/8 F	1
18	X21.107.000	NIPPLO 3/8M - 3/8M	NIPLES 3/8M - 3/8M	1
19	X21.382.000	VALVOLA MASSIMA PRESSIONE OLIO 60 bar	MAXIMUM PRESSURE OIL VALVE 60 bar	1
20	X21.362.000	RONDELLA RAME D.30x18x1,5	COPPER WASHER D.30x18x1,5	1
21	X04.683.700	SEMIASSE A 5 COLONNETTE CON FRENO	WHEEL HUB	1

SEMIASSE SINISTRO

X04.683.700

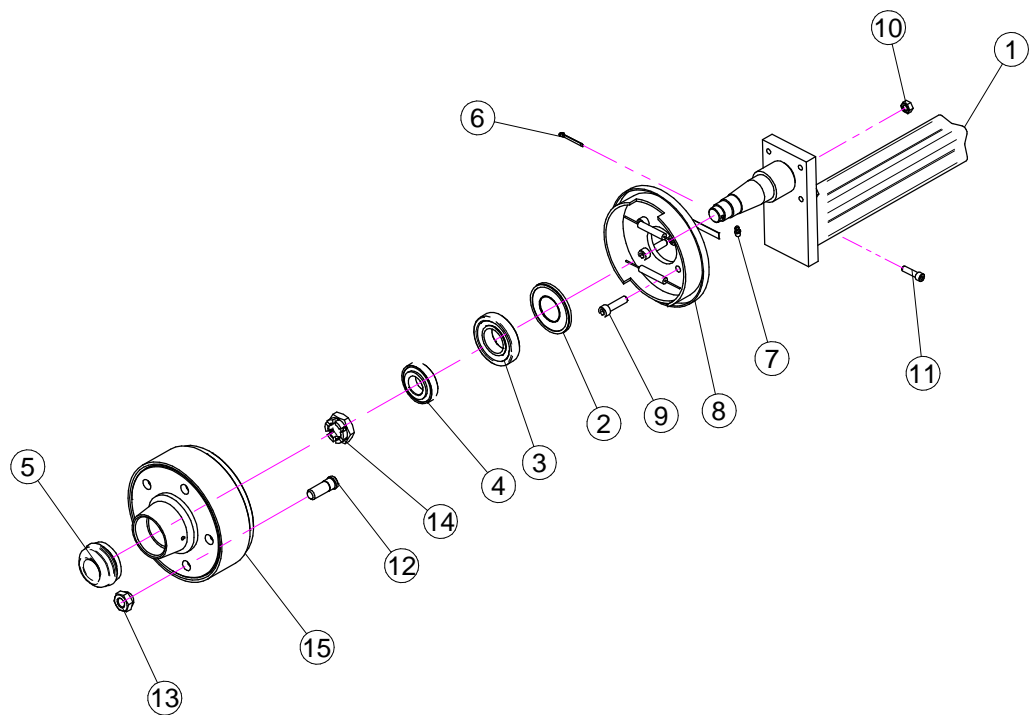
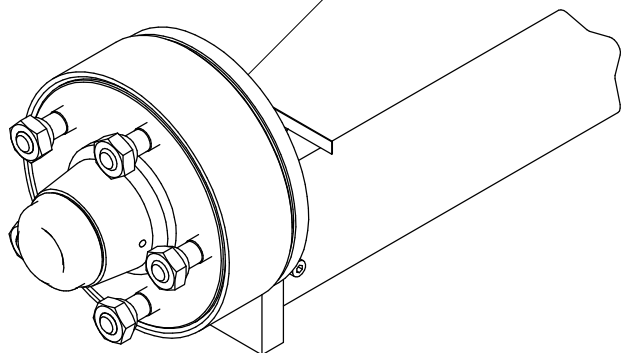

SEMIASSE DESTRO

X04.683.500

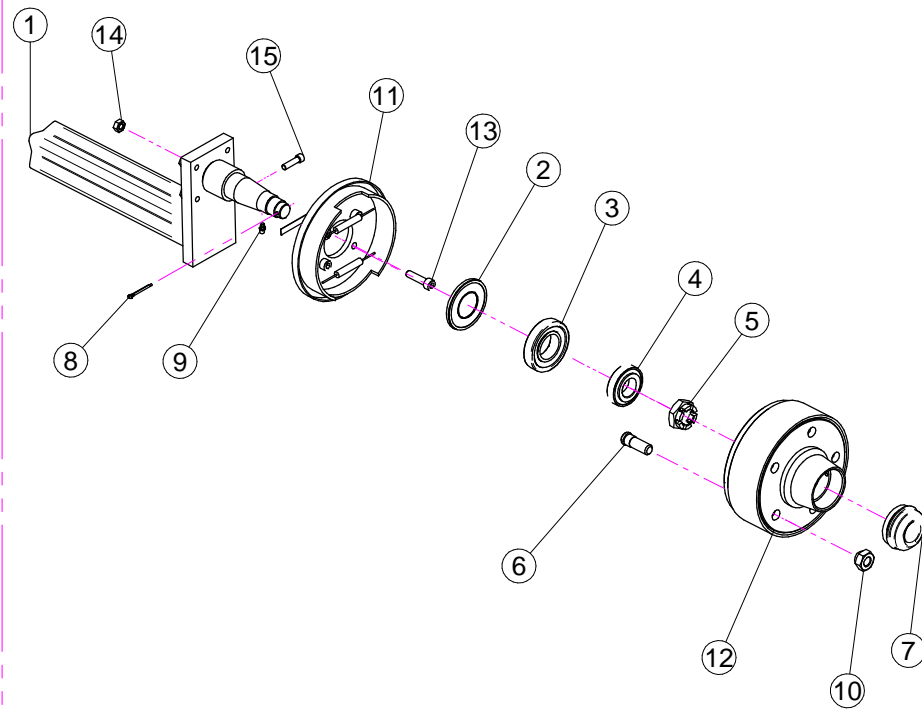
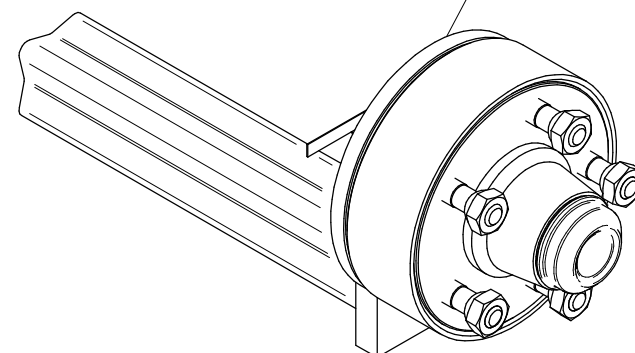

X04.683.700

X04.683.500

N°	Doc. Number	Titolo	Title	Q.tà
1	X04.683.501	SEMIASSE A 5 COLONNETTE ALLUNGATO PER FRENO	AXLE SHAFT	1
2	X20.257.000	PARA - POLVERE D. 40x80 IN GOMMA	DUST SHIELDER	1
3	XK0.030.208	CUSCINETTO A UNA CORONA DI RULLI CONICI	BEARING	1
4	XK0.030.206	CUSCINETTO A UNA CORONA DI RULLI CONICI 30206	BEARING	1
5	X04.062.001	COPERCHIETTO DI CHIUSURA	COVER	1
6	X20.259.000	COPIGLIA D.4 L=45 PER MOZZI	SPLIT PIN	1
7	XID.006.001	INGRASSATORE DIRITTO M6	GREASER	1
8	X40.388.000	FRENO SX COMPLETO	LEFT BRAKE	1
9	XTCE.010.040	VITE TESTA CIL. CON ESAGONO INCASSATO	HEXAGON SOCKET HEAD SCREW M10 x 40	1
10	XD0.10.5588G	DADO M 10 6S PG	M10 6S BIG LEAD NUT 5588	1
11	XTCE.008.030	VITE BRUGOLA TCE M8x30	BOLT TCE M8x30	1
12	X04.681.000	COLONNETTA PER SEMIASSE M16x1,5	STUD M16x1,5	1
13	X04.682.000	DADO PER COLONNETTA M 16x1.5	SPECIAL NUT	1
14	XDI.027.5594F	DADO ESAGONALE A 6 INTAGLI	SIX CASTLE NUT M27	1
15	X04.200.100	TAMBURO PER FRENO	BRAKE DRUM	1

N°	Doc. Number	Titolo	Title	Q.tà
1	X04.683.501	SEMIASSE A 5 COLONNETTE ALLUNGATO PER FRENO	AXLE SHAFT	1
2	X20.257.000	PARA - POLVERE D. 40x80 IN GOMMA	DUST SHIELDER	1
3	XK0.030.208	CUSCINETTO A UNA CORONA DI RULLI CONICI	BEARING	1
4	XK0.030.206	CUSCINETTO A UNA CORONA DI RULLI CONICI 30206	BEARING	1
5	XDI.027.5594F	DADO ESAGONALE A 6 INTAGLI	SIX CASTLE NUT M27	1
6	X04.681.000	COLONNETTA PER SEMIASSE M16x1,5	STUD M16x1,5	5
7	X04.062.001	COPERCHIETTO DI CHIUSURA	COVER	1
8	X20.259.000	COPIGLIA D.4 L=45 PER MOZZI	SPLIT PIN	1
9	XID.006.001	INGRASSATORE DIRITTO M6	GREASER	1
10	X04.682.000	DADO PER COLONNETTA M 16x1.5	SPECIAL NUT	5
11	X40.389.000	FRENO DX COMPLETO	RIGHT BRAKE	1
12	X04.200.100	TAMBURO PER FRENO	BRAKE DRUM	1
13	XTCE.010.040	VITE TESTA CIL. CON ESAGONO INCASSATO	HEXAGON SOCKET HEAD SCREW M10 x 40	4
14	XD0.10.5588G	DADO M 10 6S PG	M10 6S BIG LEAD NUT 5588	4
15	XTCE.008.030	VITE BRUGOLA TCE M8x30	BOLT TCE M8x30	1

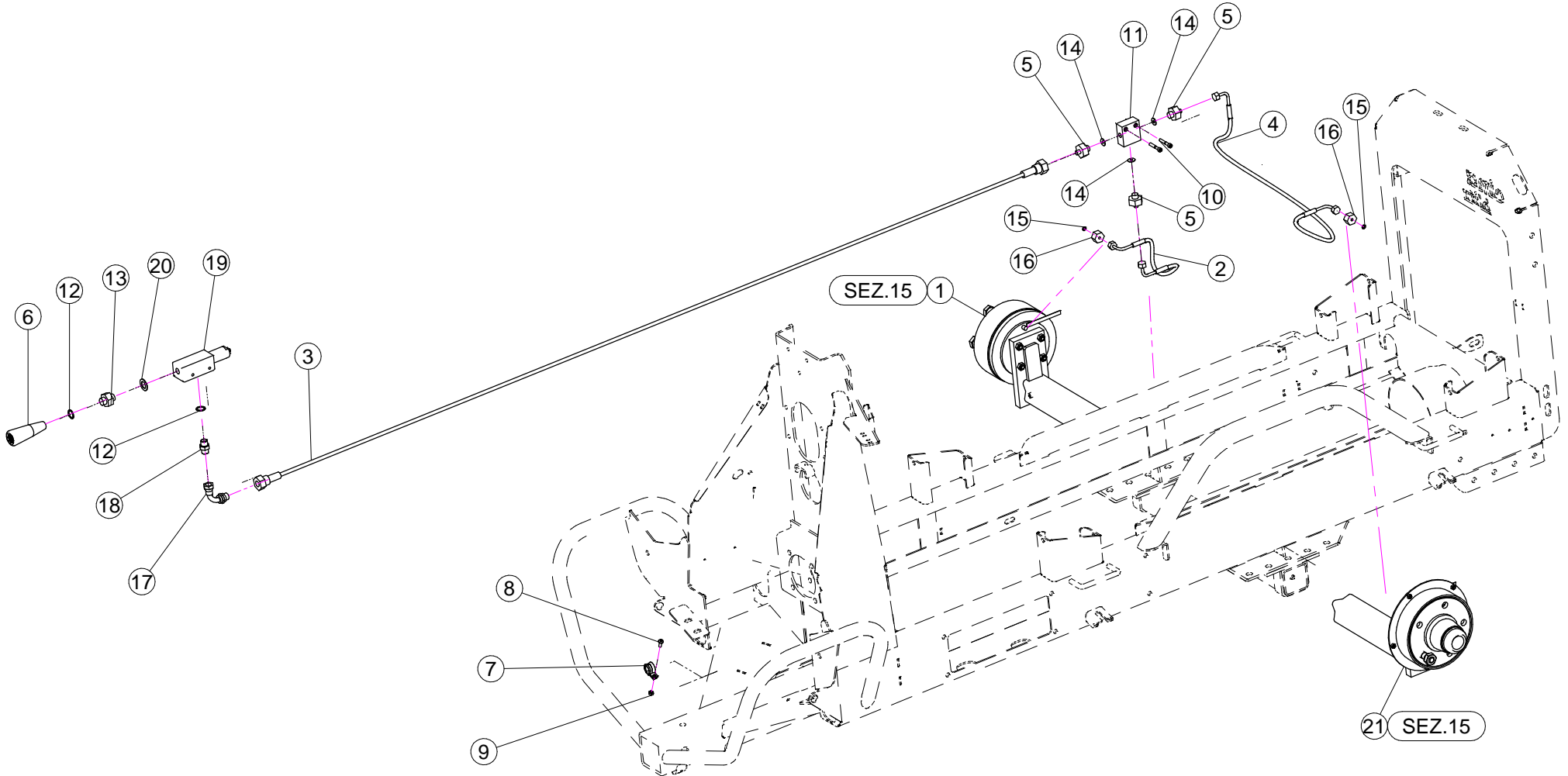

N°	Doc. Number	Titolo	Title	Q.tà
1	X04.683.500	SEMIASSE A 5 COLONNETTE CON FRENO MONTATO SU BLITZ	WHEEL HUB	1
2	X21.341.060	TUBO OLIO 1/4" L=600 CON RACCORDI	OIL HOSE 1/4" L=600 WITH FITTINGS	1
3	X21.341.350	TUBO OLIO 1/4" L=3500 CON RACCORDI	OIL HOSE 1/4" L=3500 WITH FITTINGS	1
4	X21.341.100	TUBO OLIO 1/4" L=1000 CON RACCORDI	OIL HOSE 1/4" L=1000 WITH FITTINGS	1
5	X21.342.000	NIPPLO DOPPIO 1/4" 1/4"	DOUBLE NIPLES 1/4" 1/4"	3
6	X21.343.000	INNESTO FASTER	CLUTCH	1
7	XFG.018.000	FASCETTA GOMMATA PER TUBI D.18	STICKER	1
8	XTCC.06.16	VITE TESTA A CROCE M6x16	CROSS SLOTTED SCREW M6x16	1
9	XDOT.06.5587	DADO OTTONE M6	M6 BRASS NUT 5587	1
10	XTCE.006 .040	VITE BRUGOLA TCE M6x40	BOLT TCE M6x40	2
11	X21.348.000	DISTRIBUTORE OLIO PER FRENO	BRAKE OIL DISTRIBUTOR	1
12	X21.344.000	RONDELLA RAME D.18x1,5	COPPER WASHER D.18x1,5	2
13	X21.345.000	NIPPLO RIDOTTO 3/8 - m18	NIPLES 3/8 - M18	1
14	X21.349.000	RONDELLA RAME D.1/4	COPPER WASHER D.1/4	3
15	X21.346.000	RONDELLA RAME D.10x1,5	COPPER WASHER D.10x1,5	2
16	X21.347.000	RACCORDO RAD 1803	RAD 1803 FITTING	2
17	X21.381.000	CURVA PER OLIO 3/8 M - 3/8 F	OIL BEND 3/8 M - 3/8 F	1
18	X21.107.000	NIPPLO 3/8M - 3/8M	NIPLES 3/8M - 3/8M	1
19	X21.382.000	VALVOLA MASSIMA PRESSIONE OLIO 60 bar	MAXIMUM PRESSURE OIL VALVE 60 bar	1
20	X21.362.000	RONDELLA RAME D.30x18x1,5	COPPER WASHER D.30x18x1,5	1
21	X04.683.400	SEMIASSE A 5 COLONNETTE CON FRENO	WHEEL HUB	1

SEMIASSE SINISTRO

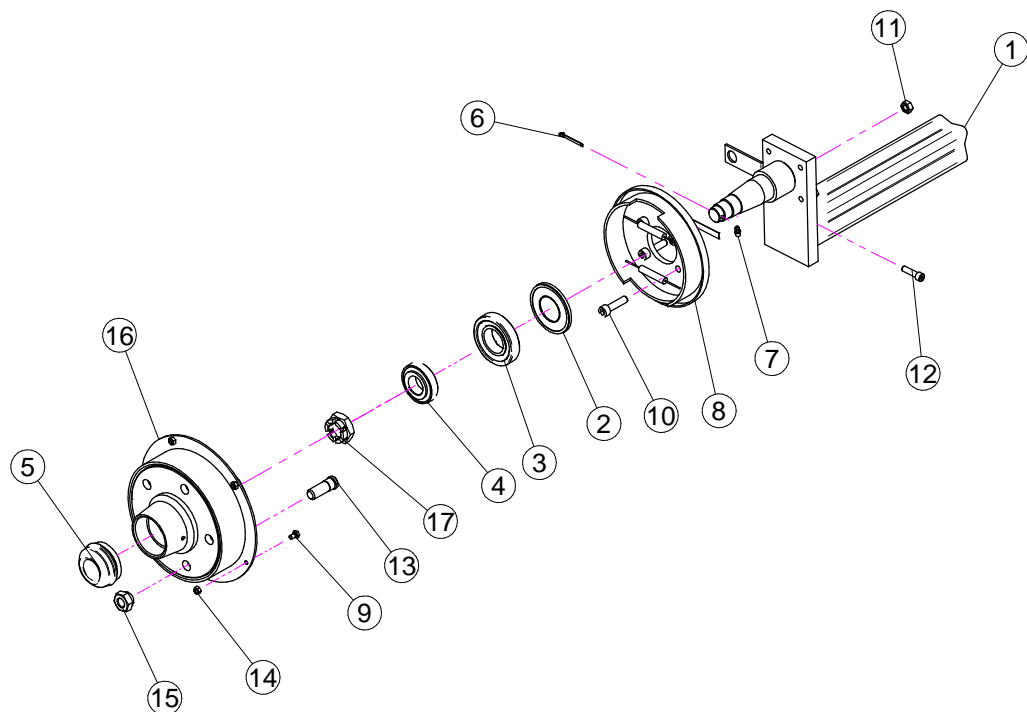
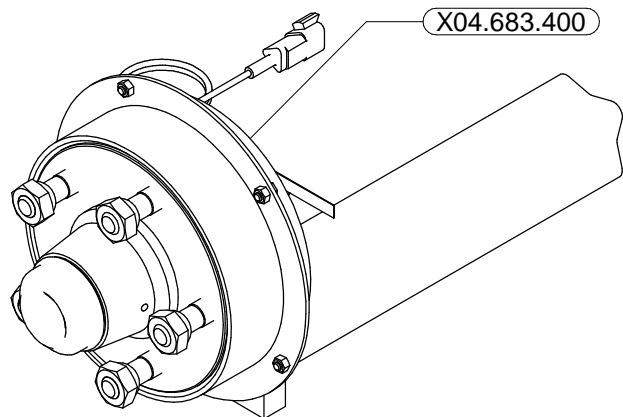

SEMIASSE DESTRO

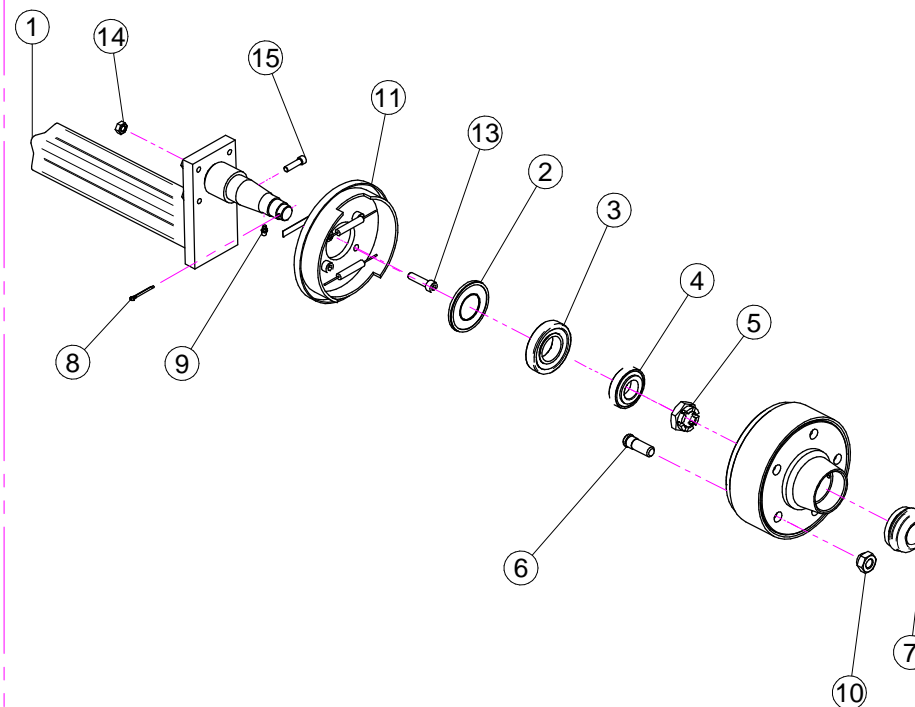
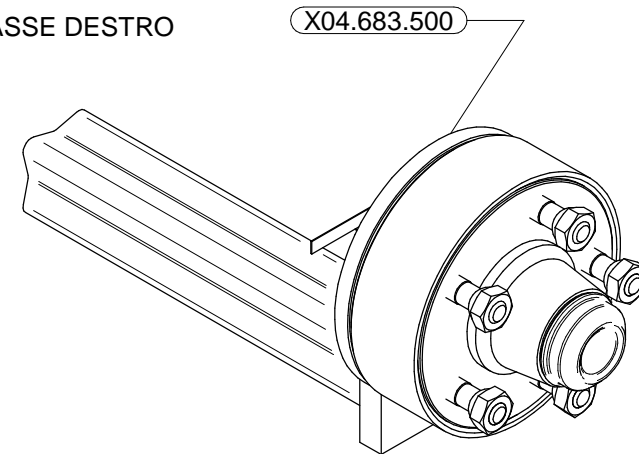

X04.683.400

X04.683.500

N°	Doc. Number	Titolo	Title	Q.tà
1	X04.683.401	SEMIASSE A 5 COLONNETTE ALLUNGATO PER FRENO ED EPA	AXLE SHAFT	1
2	X20.257.000	PARA - POLVERE D. 40x80 IN GOMMA	DUST SHIELDER	1
3	XK0.030.208	CUSCINETTO A UNA CORONA DI RULLI CONICI	BEARING	1
4	XK0.030.206	CUSCINETTO A UNA CORONA DI RULLI CONICI 30206	BEARING	1
5	X04.062.001	COPERCHIETTO DI CHIUSURA	COVER	1
6	X20.259.000	COPIGLIA D.4 L=45 PER MOZZI	SPLIT PIN	1
7	XID.006.001	INGRASSATORE DIRITTO M6	GREASER	1
8	X40.388.000	FRENO SX COMPLETO	LEFT BRAKE	1
9	XTE.006.010T	VITE TE M6x10	SCREW TE M6x10	1
10	XTCE.010.040	VITE TESTA CIL. CON ESAGONO INCASSATO	HEXAGON SOCKET HEAD SCREW M10 x 40	1
11	XD0.10.5588G	DADO M 10 6S PG	M10 6S BIG LEAD NUT 5588	1
12	XTCE.008.030	VITE BRUGOLA TCE M8x30	BOLT TCE M8x30	1
13	X04.681.000	COLONNETTA PER SEMIASSE M16x1,5	STUD M16x1,5	1
14	XD0.06.5588G	DADO M6	NUT M6	1
15	X04.682.000	DADO PER COLONNETTA M 16x1.5	SPECIAL NUT	1
16	X04.200.000	TAMBURO PER FRENO E EPA	BRAKE DRUM	1
17	XDI.027.5594F	DADO ESAGONALE A 6 INTAGLI	SIX CASTLE NUT M27	1

N°	Doc. Number	Titolo	Title	Q.tà
1	X04.683.501	SEMIASSE A 5 COLONNETTE ALLUNGATO PER FRENO	AXLE SHAFT	1
2	X20.257.000	PARA - POLVERE D. 40x80 IN GOMMA	DUST SHIELDER	1
3	XK0.030.208	CUSCINETTO A UNA CORONA DI RULLI CONICI	BEARING	1
4	XK0.030.206	CUSCINETTO A UNA CORONA DI RULLI CONICI 30206	BEARING	1
5	XDI.027.5594F	DADO ESAGONALE A 6 INTAGLI	SIX CASTLE NUT M27	1
6	X04.681.000	COLONNETTA PER SEMIASSE M16x1,5	STUD M16x1,5	5
7	X04.062.001	COPERCHIETTO DI CHIUSURA	COVER	1
8	X20.259.000	COPIGLIA D.4 L=45 PER MOZZI	SPLIT PIN	1
9	XID.006.001	INGRASSATORE DIRITTO M6	GREASER	1
10	X04.682.000	DADO PER COLONNETTA M 16x1.5	SPECIAL NUT	5
11	X40.389.000	FRENO DX COMPLETO	RIGHT BRAKE	1
12*	X04.200.100	TAMBURO PER FRENO	BRAKE DRUM	1
13	XTCE.010.040	VITE TESTA CIL. CON ESAGONO INCASSATO	HEXAGON SOCKET HEAD SCREW M10 x 40	4
14	XD0.10.5588G	DADO M 10 6S PG	M10 6S BIG LEAD NUT 5588	4
15	XTCE.008.030	VITE BRUGOLA TCE M8x30	BOLT TCE M8x30	1