

(⌘) A richiesta / Optional Devices

Sez. 23 (a)
Timone Sterzante
Steering Drawbar

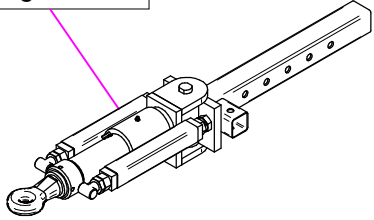

Sez. 23 (a)
Timone Sterzante a 3 punti
Steering Drawbar 3 points

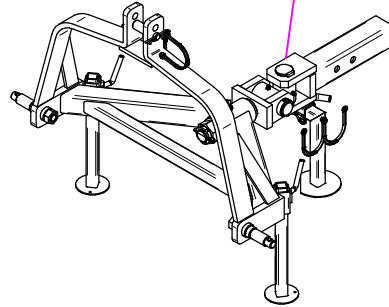

Sez.22 (a)
Tubazione Riempimento
Filling pipe

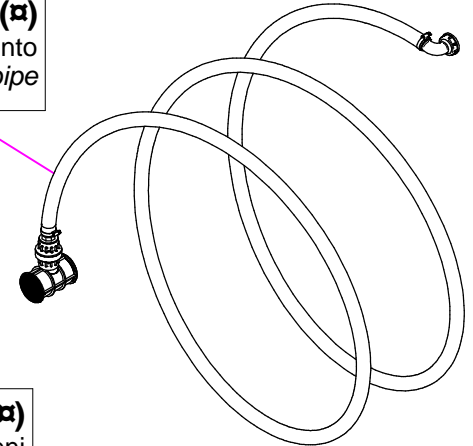

Sez. 23 (a)
Timone Sterzante a 2 punti
Steering Drawbar 2 points

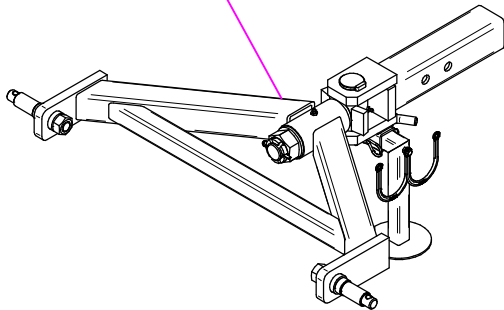

Sez.06E (a)
Elettrovalvola Regolazione Pressione
Solenoid Valves Regulation Pressure

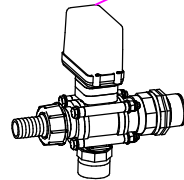

Sez.15A (a)
Freni
Brakes

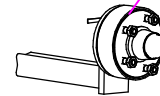

Sez.02E (a)
Kit Lava barattoli
Container Washing
Device Kit

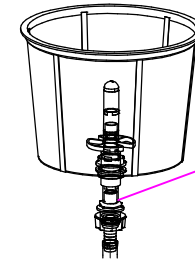

Sez.14 (a)
Ruote in Tandem
Tandem Wheels

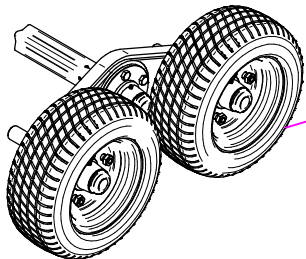

Sez. 26 (a)
Kit Luci
Kit lights

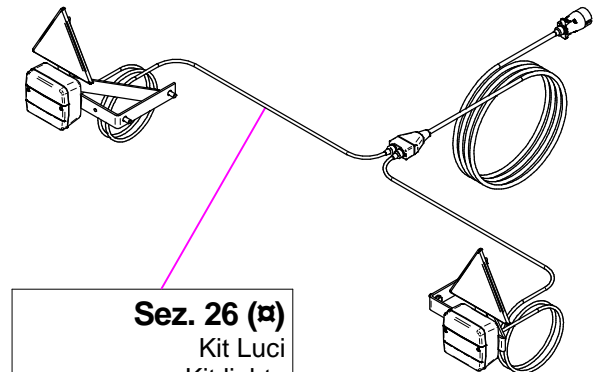

(a) A richiesta / Optional Devices

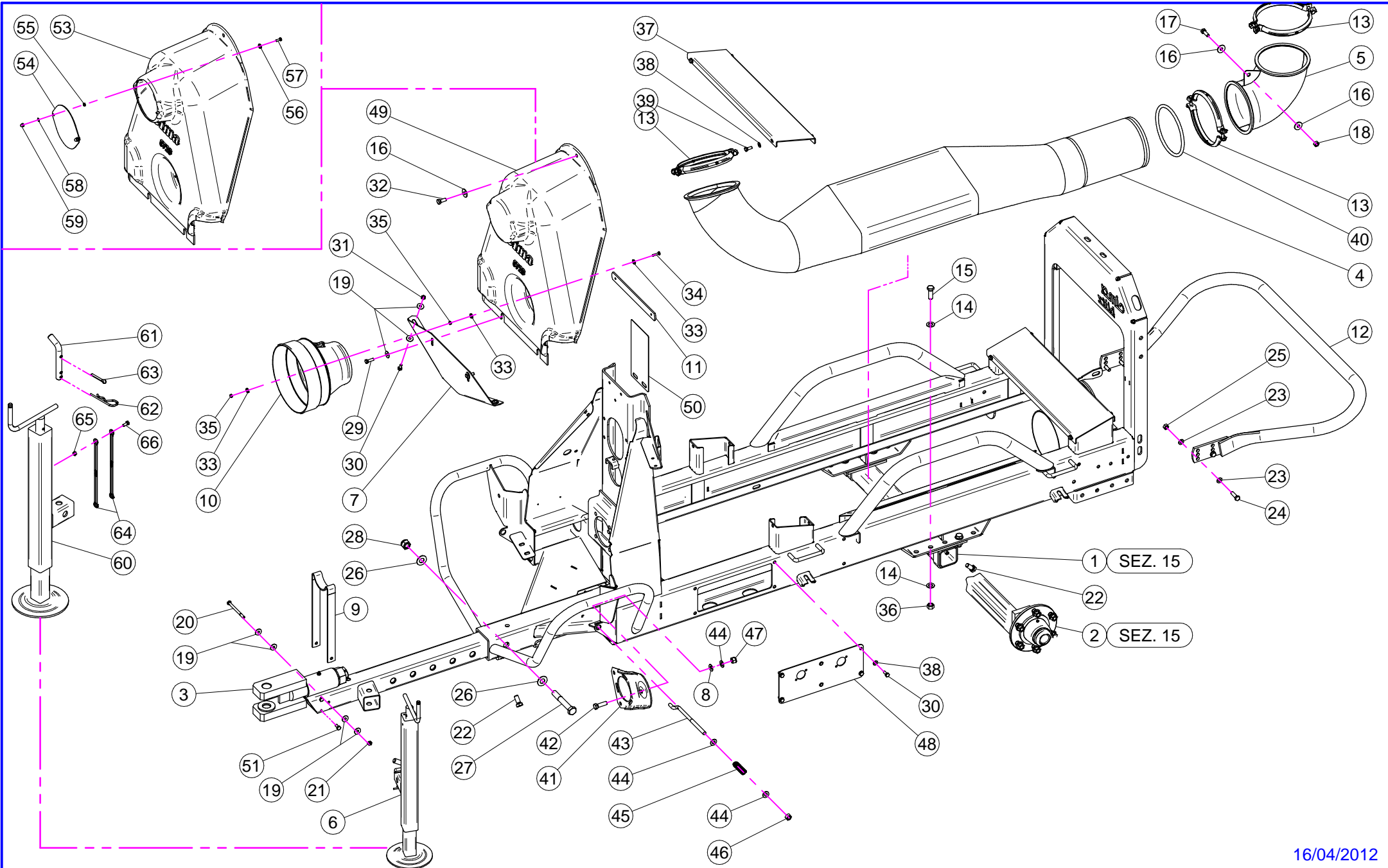

N°	Doc. Number	Titolo	Title	Q.tà	Note
1	X40.126.000	ASSALE	AXLE	1	
2	X40.020.150	ASSIEME MOZZO 6 COLONNETTE	HUB 6 COLONNETTE	2	
3	X40.136.200	TIMONE "TIPO USA"	DRAW-BAR "TIPO USA"	1	
4	X40.141.100	TUNNEL PASSAGGIO ARIA BLITZ	AIR WAY TUNNEL	1	
5	X05.615.000	CURVA D.175 90°	ELBOW D.175 90°	1	
6	X04.993.070C	PIEDE D'APPOGGIO ESTRAIBILE	EXTRACTABLE JACK STAND	1	
7	X20.531.000	LAMIERA FISSAGGIO CARTER	CARTER FIXING PLATE	1	
8	XMT.012.000	MOLLA A TAZZA D. 12	WASHER D.12	1	
9	X20.409.000	SUPPORTO PER CARDANO	SHAFT SUPPORT	1	
10	X02.441.000	CONTROCUFFIA D.240 PER CARDANO	SHAFT CONE D.240	1	
11	X20.532.000	PIATTO BLOCCAGGIO CARTER	FRONT HOUSING BLOCKING PLATE	1	
12	X40.000.000	CERCHIO DI PROTEZIONE	BUMPER	1	
13	X05.616.000	COLLARE PER TUBI D.175	PIPE CLAMP D.175	3	
14	XRP.014.000	RONDELLA PIANA D.14	WASHER D.14	8	
15	XTE.014.040T	VITE TE M14 x 40	SCREW TE M14 x 40	4	
16	XRP.010.030	RONDELLA PIANA D.10 x 30 mm	WASHER D.10 x 30 mm	3	
17	XTE.010.030T	VITE TE M10 x 30	SCREW TE M10 x 30	1	
18	XD0.10.5587G	DADO M10	NUT M10	1	
19	XRP.008.024	RONDELLA PIANA LARGA D.8x24	WASHER D.8x24	10	
20	XTE.008.100	VITE TE M8 x 100	SCREW TE M8 x 100	1	
21	XDA.008.0AG	DADO AUTOBLOCCANTE M8	SELF LOCKING NUT M8	1	
22	XTE.014.030T	VITE TE M14x30	SCREW TE M14x30	6	
23	XRP.010.000	RONDELLA PIANA D.10	WASHER D.10	8	
24	XTE.010.035T	VITE TE 10 x 35	SCREW TE 10 x 35	4	
25	XD0.10.5587G	DADO M10	NUT M10	4	
26	XRP.018.000	RONDELLA PIANA D.18	WASHER	2	
27	XTE.018.120	VITE TE M18 x 120	SCREW TE M18 x 120	1	
28	XDA.018.0AG	DADO AUTOBLOCCANTE M18x2.5	SELF LOCKING NUT M18	1	
29	XTE.008.025T	VITE TE M8 x 25	SCREW TE M8 x 25	2	
30	XTE.008.020T	VITE TE 8x20	SCREW TE 8x20	10	
31	XD0.08.5588G	DADO M8	NUT M8	2	
32	XTE.010.025T	VITE TE 10x25T	SCREW TE 10x25T	1	
33	XRD.006.000	RONDELLA DENTELLATA D.6	TAB WASHER D.6	9	
34	XTE.006.025T	VITE TE M6x25	SCREW TE M6x25	3	
35	XD0.06.5588G	DADO M6	NUT M6	6	
36	XD0.014.5587G	DADO M 14	NUT M 14	4	

N°	Doc. Number	Titolo	Title	Q.tà	Note
37	X40.301.000	LAMIERA DI APPOGGIO SERBATOIO	PLATE TANK	2	
38	XRP.008.000	RONDELLA PIANA D.8	WASHER D.8	12	
39	XTE.008.025T	VITE TE 8X25	SCREW TE M8x25	4	
40	X40.147.000	GUARNIZIONE PER TUNNEL BLITZ 45-50	GASKET FOR TUNNEL 45-50	1	
41	X02.978.000SX	SUPPORTO POMPA TIPO NUOVO	BRACKET	1	
42	XTE.012.040T	VITE TE M12X40 UNI 5739	BOLT TE M12X40	1	
43	X20.447.000	TENDICINGHIA M12 PER POMPA	BELT STRETCHER FOR PUMP	1	
44	XRP.012.000	RONDELLA PIANA D. 12	WASHER D. 12	3	
45	X02.964.000	MOLLA PER POMPA CD 32	CD 32 PUMP SPRING	1	
46	XD0T.12.5587	DADO OTTONE M12	M12 BRASS NUT	1	
47	XDA.012.0AG	DADO AUTOBLOCCANTE M12	NUT M12	1	
48	X40.378.000	PIASTRA COPRI RUBINETTI CON INSERTI	PLATE	1	
49	X05.723.150	CARTER ANTERIORE PER 1 POMPA	FRONT HOUSING FOR 1 PUMP	1	
50	X50.355.000	SUPPORTO ADESIVO PRODOTTO	PRODUCT NOTE SUPPORT	1	
51	XTE.008.016T	VITE TE M8x16	SCREW TE M8x16	2	

N°	Doc. Number	Titolo	Title	Q.tà	Note
53	X05.723.050	CARTER ANTERIORE PER 1 POMPA	FRONT HOUSING FOR 1 PUMP	1	
54	X40.333.000	COPERCHIO DISINNESTO	FAN CLUTCH LID	1	
55	XD0.06.5589G	DADO M6 BASSO	NUT M6	2	
56	XRD.006.000	RONDELLA DENTELLATA D.6	TAB WASHER D.6	2	
57	XTE.006.016T	VITE TE M6x16	SCREW TE M6x16	2	
58	XRP.006.000	RONDELLA PIANA D. 6	WASHER D.6	2	
59	XDC.06.5721I	DADO DIN 1587 6x1-6-10	NUT DIN 1587 6x1-6-10	2	

N°	Doc. Number	Titolo	Title	Q.tà	Note
60	X04.993.070	CORPO PIEDE D'APPOGGIO	JACK STAND BODY	1	
61	X20.505.000	SPINOTTO PIEDE D' APPOGGIO	PIN JACK STAND	1	
62	X00.100.004	COPIGLIA D.4	SPLIT PIN D.4	1	
63	XCP.006.040I	COPIGLIA D.6 Lg.40	PIN D.6 Lg.40	1	
64	X21.183.000	STRISCIA FERMATAPPI	CAP STOP	2	
65	XD0.06.5588G	DADO M6	NUT M6	1	
66	XTE.006.016T	VITE TE M6x16	SCREW TE M6x16	1	

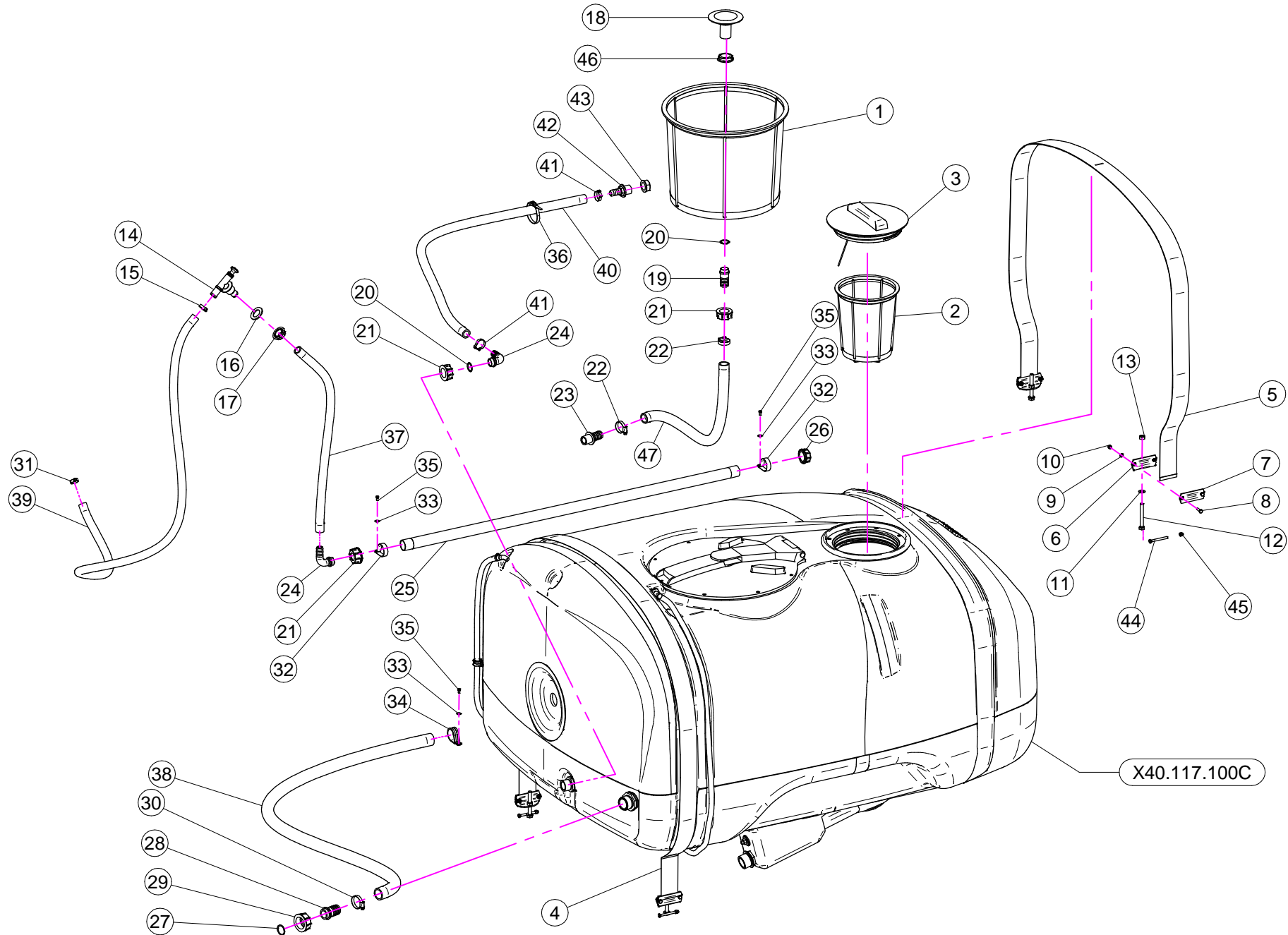

N°	Doc. Number	Titolo	Title	Q.tà	Note
1	X02.404.100	FILTRO A TAZZA 400 x 330	BASKET FILTER 400 x 330	1	
2	X02.298.000	FILTRO A TAZZA D.204	BASKET FILTER D.204	1	
3	X02.476.100	COPERCHIO FILETTATO D.255 CON FILO	THREADED LID D.255 WITH ROPE	1	
4	X02.481.280	FASCIA IN NYLON 60 mm L=2800	NYLON BAND 60 mm L=2800	1	
5	X02.481.253	FASCIA IN NYLON 60 mm L=2530	NYLON BAND 60 mm L=2530	1	
6	X20.512.000	STAFFA ANCORAGGIO FASCE	BRACKET	4	
7	X20.513.000	PIASTRINA SERRAGGIO FASCE	SHAPED PLATE	4	
8	XTE.006.020T	VITE TE M6 x 20	SCREW TE M6 x 20	8	
9	XRP.006.000	RONDELLA PIANA D. 6	WASHER D.6	8	
10	XDA.006.0AG	DADO AUTOBLOCCANTE M6	SELF LOCKING NUT M6	8	
11	XRP.010.000	RONDELLA PIANA D.10	WASHER D.10	4	
12	XTE.010.080T	VITE M10x80	M10x80 BOLT	4	
13	XDOT.10.5587	DADO OTTONE M10	M10 BRASS NUT	4	
14	X02.135.000	VALVOLA A PISTONCINO COMPLETA	COMPLETE PISTON VALVE	1	
15	XFC.023.5.025	FASCETTA COBRA 23,5 - 25	KOBRA CLAMP 23,5 - 25	1	
16	X02.032.000	GUARNIZIONE D.26x40 SP. 2	GASKET D.26x40 SP. 2	1	
17	X00.541.000	GHIERA 3/4"	NUT 3/4"	1	
18	X00.131.000	PRESA ANTIVORTICE 1"	1" VORTIX DAMPER DRIVE	1	
19	X00.055.021	RACCORDO DIRITTO PG D.25	STRAIGHT HOSE R.H D.25	1	
20	XOR.000.132	OR D.23,81 x 2,62	23,81 x 2,62 O-RING GASKET	2	
21	X00.055.24.2	GIRELLO 1" GAS	1" FLY NUT	3	
22	XF0.023.035I	FASCETTA A VITE 23/35 W4 INOX	STAINLESS STEEL CLIP	2	
23	X20.793.000	RACCORDO DIRITTO P.G. D.25 3/4" GAS M.	HOSETAIL R.H. D.25 3/4" GAS M.	1	
24	X00.055.038	RACCORDO CURVO A P.G. D.19	CURVED UNION WITH R.H. D.19	2	

N°	Doc. Number	Titolo	Title	Q.tà	Note
25	X40.035.001	TUBO FORATO 1" L=1200	PERFORATED HOSE 1" L=1200	1	
26	XTF.001.000	TAPPO 1"	PACKING	1	
27	XOR.003.112	OR D.28,24x2,62	O-RING D.28,24x2,62	1	
28	X00.058.028	RACCORDO DIRITTO PG D. 30	STRAIGHT HOSE R.H D.30	1	
29	X00.058.006	GIRELLO 1" 1/4 GAS	1" 1/4 FLY NUT	1	
30	XF0.025.040I	FASCETTA A VITE 25/40 W4 INOX	STAINLESS STEEL CLIP	1	
31	XFC.022,5.024	FASCETTA COBRA 22,5 - 24	KOBRA CLAMP 22,5 - 24	1	
32	XFN.035.000	FASCETTA IN NYLON PER TUBI D. 30	STICKER	2	
33	XRP.005.015I	RONDELLA PIANA D. 5x15	WASHER D. 5x15	3	
34	XFG.040.000	FASCETTA GOMMATA PER TUBI D.30	STICKER	1	
35	XTE.005.010I	VITE TE M5 x 10	SCREW TE M5 X 10	3	
36	X02.355.000	FASCETTA D'ASSEMBLAGGIO 292 mm	NYLON ASSEMBLY CLAMP	3	
37	X02.212.080	TUBO D. 19x26 L= 800	HOSE D. 19x26 L= 800	1	
38	X02.238.120	TUBO SPIRALATO D. 30 L= 1200	HOSE D. 30 L= 1200	1	
39	X02.372.125	TUBO SPIRALATO D. 19 L= 1250	HOSE D. 19 L= 1250	1	
40	X02.212.130	TUBO D. 19x28 L= 130	HOSE D. 19x28 L= 130	1	
41	XFC.027,5.029	FASCETTA COBRA 27,08 - W8	KOBRA CLAMP 27,08 - W8	2	
42	X00.418.000	RACCORDO DIRITTO P.G. 19 3/4" GAS	STRAIGHT UNION R.H.19 3/4 GAS	1	
43	X02.182.100	TAPPO 3/4" FEMMINA CON FORO D. 8	FEMALE 3/4" CAP	1	
44	XTE.006.060I	VITE TE M6x60 INOX	INOX M6x60 TE SCREW	4	
45	XDC.06.5721I	DADO DIN 1587 6x1-6-10	NUT DIN 1587 6x1-6-10	4	
46	X00.542.000	GHIERA 1"	NUT 1"	1	
47	X20.809.120	TUBO D.25 CON RAMINO L=1200	HOSE D.25 L=1200	1	

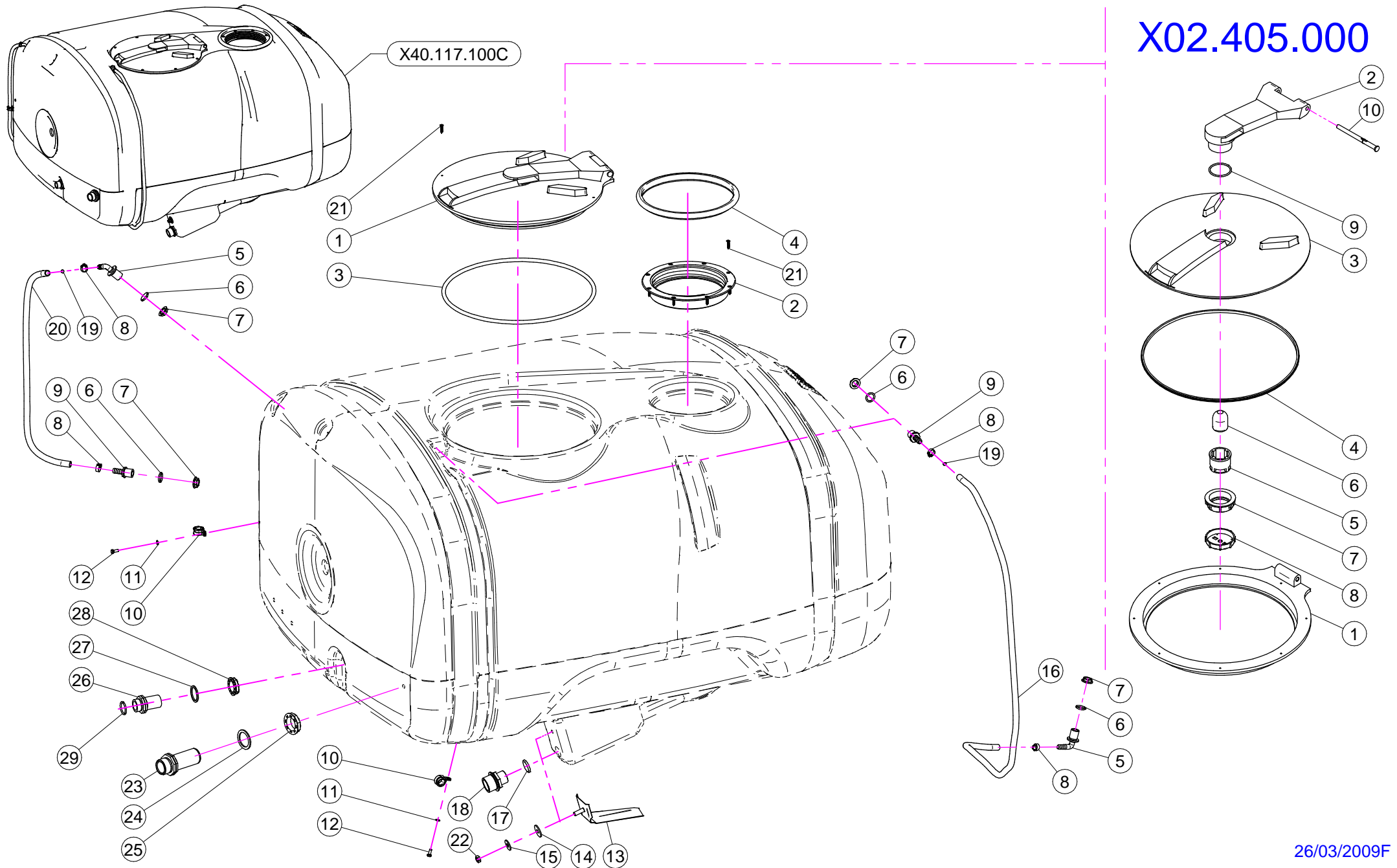

N°	Doc. Number	Titolo	Title	Q.tà	Note
1	X02.405.000	COPERCHIO RIBALTABILE	HINGED TANK LID	1	
2	X02.477.000	ANELLO FILETTATO D.255	THREADED RING D.255	1	
3	X02.405.000.L	GUARNIZIONE	GASKET	1	
4	X02.477.000.A	GUARNIZIONE PER ANELLO FILETTATO D.255	THREADED RING GASKET D.255	1	
5	X02.457.000	PORTAGOMMA D.13 A 90° M. 1/2"	HOSETAIL D.13 90° M. 1/2"	2	
6	XOR.004.081	OR D.20,22 x 3,53	20,22 x 3,53 O-RING GASKET	4	
7	X02.458.000	GHIERA 1/2"	LOCK RING 1/2"	4	
8	XFC.016,5.018	FASCETTA COBRA 16,5 - 18	KOBRA CLAMP 16,5 - 18	4	
9	X02.482.000	RACCORDO DRITTO P.G.D.13 M. 1/2"	HOSETAIL MALE THREADED 1/2"	2	
10	XFG.018.000	FASCETTA GOMMATA PER TUBI D.18	STICKER	2	
11	XRP.006.000	RONDELLA PIANA D. 6	WASHER D.6	2	
12	XTE.006.016T	VITE TE M6X16	SCREW TE M6X16	2	
13	X20.498.002	ANTIVORTICE IN ACCIAIO INOX	STAINLESS STEEL ANTI-VORTEX	1	
14	X20.436.000	GUARNIZIONE SPECIALE PER ANTIVORTICE	SPECIAL GARNISHING FOR ANTIWHIRL	1	
15	XRP.010.030	RONDELLA PIANA D.10 x 30 mm	WASHER D.10 x 30 mm	1	
16	X02.378.160	TUBETTO VITREO D.12X16 L=1600	HOSE VITREO D.12X16 L=1600	1	
17	XOR.000.507	OR D.27 x 5	27 x 5 O-RING GASKET	1	
18	X00.045.012	RIDUZIONE 1" 1/4 M - 1" M	1" 1/4 M - 1" M REDUCER NIPPLE	1	
19	X02.478.000	SFERA ROSSA D.8,5 PER LIVELLO	RED FLOATING BALL D.8,5	2	
20	X02.378.085	TUBETTO VITREO D 12X16 L= 850	HOSE VITREO D 12X16 L= 850	1	
21	XTAS.04,2.025I	VITE AUTOFILETTANTE 4,2 x 25	SELFTHREADED SCREW 4,2 x 25	16	
22	XDOT.10.5587	DADO OTTONE M10	M10 BRASS NUT	1	
23	X00.345.000	NIPPLO 1" 1/4 + 1" 1/4 GAS	NIPPLE 1" 1/4 + 1" 1/4 GAS	1	
24	X02.033.000	GUARNIZIONE	GASKET	1	
25	X00.543.000	GHIERA 1" 1/4 GAS	NUT 1" 1/4 GAS	1	
26	X00.055.134.L	NIPPLO 1" / 1" GAS FILETTO LUNGO TAGLIATO	CUTTED LONG NIPPLE 1" / 1" GAS	1	
27	X02.066.000	GUARNIZIONE D.33 x 45	GASKET D.33 x 45	1	
28	X00.542.000	GHIERA 1"	NUT 1"	1	
29	XOR.004.118	OR D.29,75 x 3,53	29,75 x 3,53 O-RING GASKET	1	

X02.405.000

N°	Doc. Number	Titolo	Title	Q.tà	Note
1	X02.405.000.B	ANELLO BASE	BASE RING	1	
2	X02.405.001	BRACCIO	ARM	1	
3	X02.405.000.A	DISCO DI CHIUSURA	GRIPPING PLATE	1	
4	X02.405.002	GUARNIZIONE SAGOMATA	SHAPED GASKET	1	
5	X20.787.000.G	CORPO VALVOLA DI SFIATO	BREATHER VALVE	1	
6	X20.787.000.F	SFERA GALLEGGIANTE	FLOATING BALL	1	
7	X20.787.000.H	GHIERA	RING NUT	1	
8	X20.787.000.I	TAPPO PER VALVOLA DI SFIATO	CAP FOR BREATHER VALVE	1	
9	XOR.000.512	OR D.51 x 3,5	51 x 3,5 O-RING GASKET	1	
10	X20.787.000.D	PERNO	PIN	1	

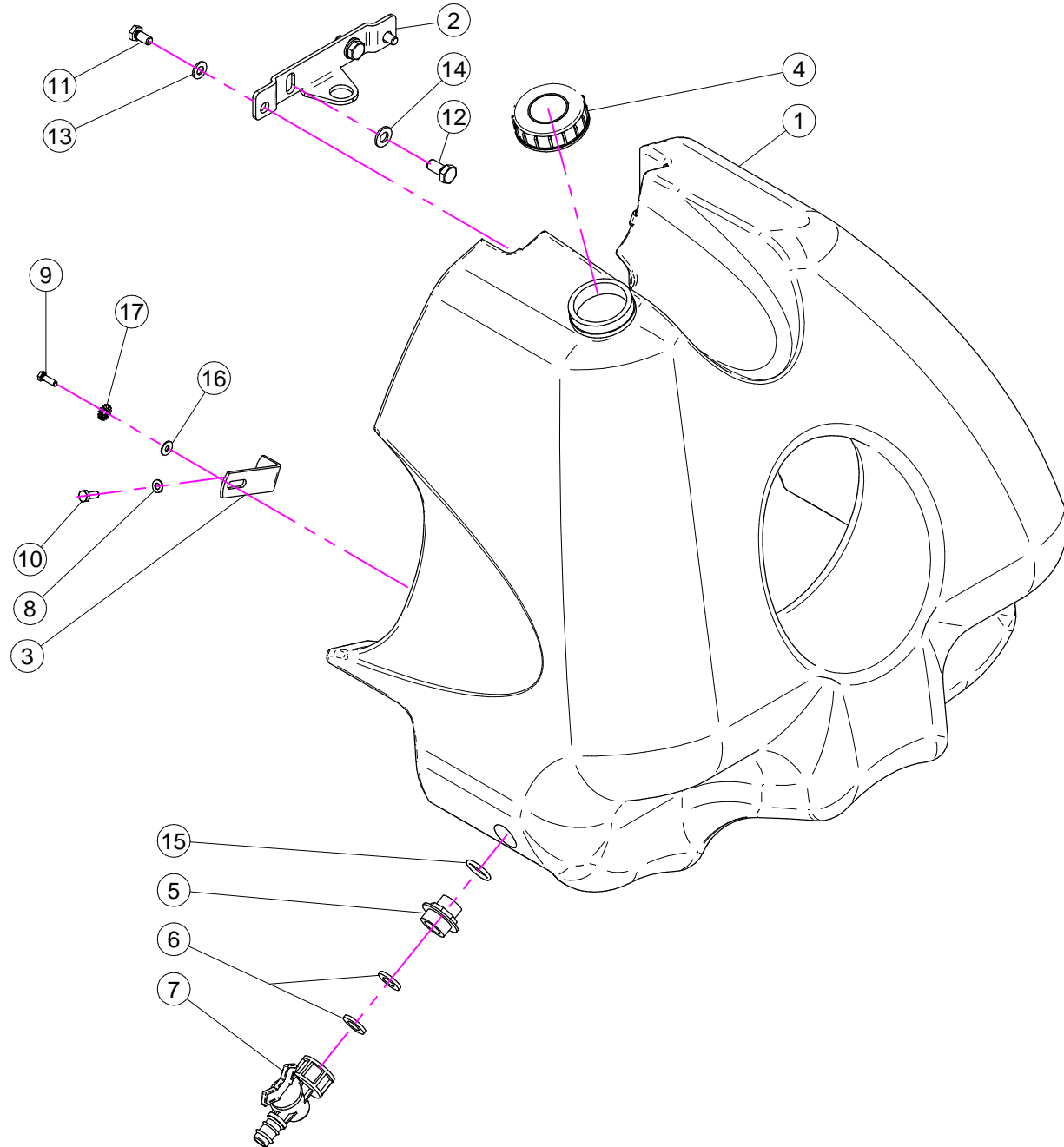
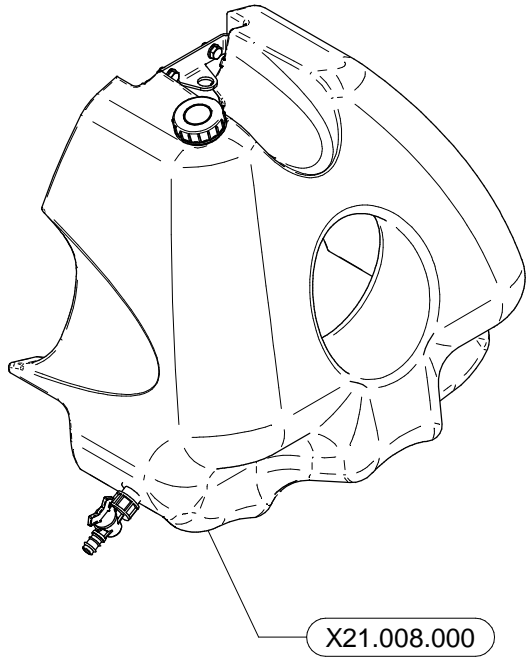

N°	Doc. Number	Titolo	Title	Q.tà	Note
1	X40.322.000	SERBATOIO LAVAMANI 30 Lt.	HAND-WASHING TANK 30 Lt.	1	
2	X40.323.000	STAFFA FISSAGGIO SERBATOIO LAVAMANI	FIXING BRACKET	1	
3	X40.324.000	PIASTRA PER SERBATOIO LAVAMANI SERIE 45	BRACKET FOR HAND-WASHING TANK 45 SERIES	2	
4	X02.460.000	COPERCHIO FILETTATO FEMMINA	FEMALE THREADED TANK LID	1	
5	X00.055.044	NIPPLO 1/2" GAS 3/4" GAS	NIPPLE 1/2" - 3/4" GAS	1	
6	X02.030.010	GUARNIZIONE TAPPO DISTRIBUTORE	GASKET	2	
7	X02.497.000	RUBINETTO FEMMINA 3/4"	3/4" FEMALE VALVE	1	
8	XRP.006.000	RONDELLA PIANA D. 6	WASHER D.6	2	
9	XTE.005.016I	VITE TE M5X16	SCREW TE M5X16	2	
10	XTE.006.016T	VITE TE M6X16	SCREW TE M6X16	2	
11	XTE.008.016T	VITE TE M8x16	SCREW TE M8x16	2	
12	XTE.010.020T	VITE TE M10 x 20	SCREW TE M10 x 20	2	
13	XRP.008.000	RONDELLA PIANA D.8	WASHER D.8	2	
14	XRP.010.000	RONDELLA PIANA D.10	WASHER D.10	2	
15	XOR.004.081	OR D.20,22 x 3,53	20,22 x 3,53 O-RING GASKET	1	
16	XRP.005.015I	RONDELLA PIANA D. 5x15	WASHER D. 5x15	2	
17	XRD.006.000	RONDELLA DENTELLATA D.6	TAB WASHER D.6	2	

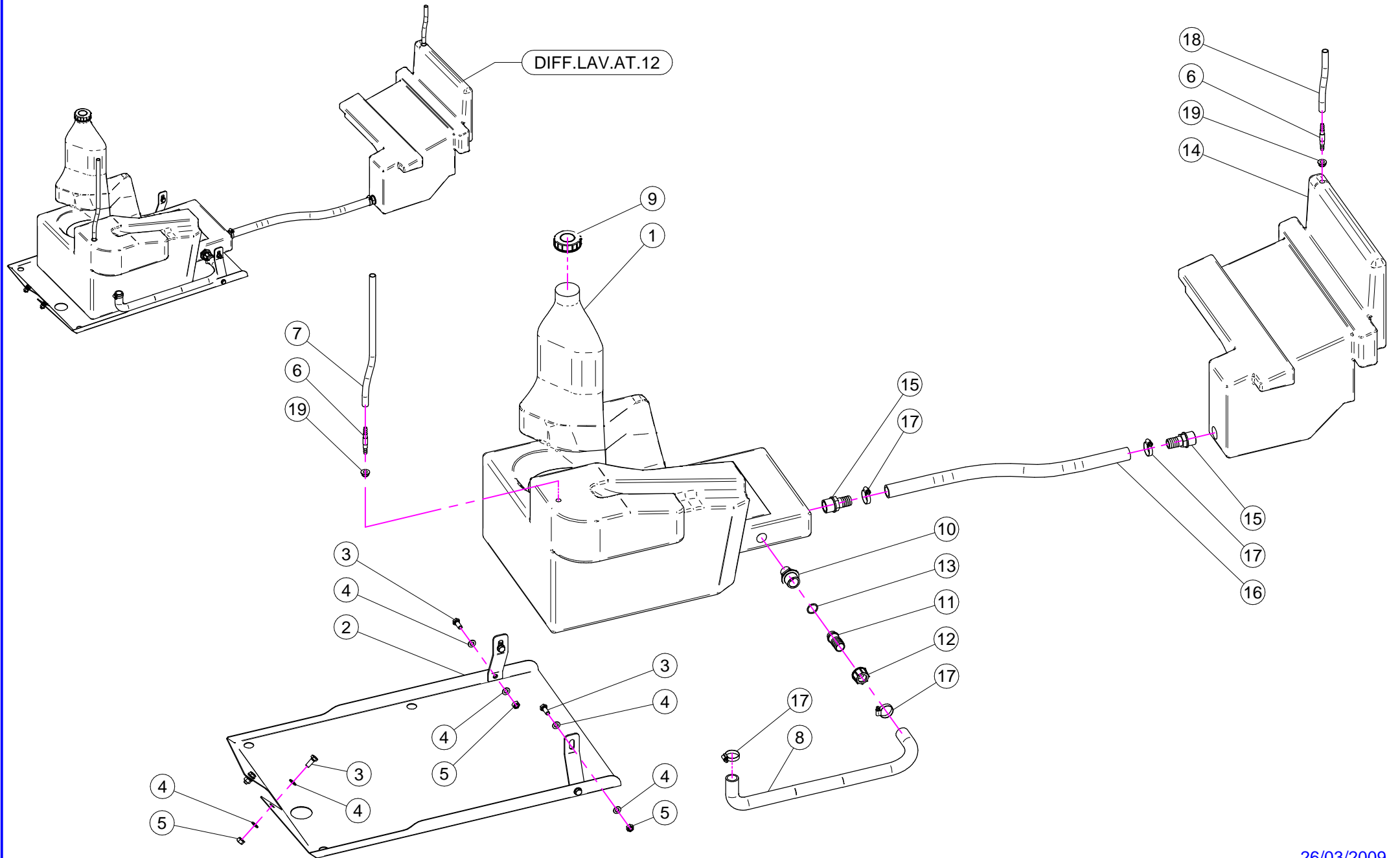

N°	Doc. Number	Titolo	Title	Q.tà	Note
1	X40.299.000	SERBATOIO LAVAIMPIANTI LT. 60	RESERVOIR TANK LT. 60	1	
2	X40.306.000	PROTEZIONE LAVAIMPIANTI	RESERVOIR KIT PROTECTION	1	
3	XTE.010.025T	VITE TE 10x25T	SCREW TE 10x25T	6	
4	XRP.010.000	RONDELLA PIANA D.10	WASHER D.10	12	
5	XD0.10.5587G	DADO M10	NUT M10	6	
6	X20.934.000	PORTAGOMMA D.8	STRAIGHT HOSE D.8	2	
7	X02.213.060	TUBETTO DI SFIATO D.10 L=600	BREATHER PIPE D.10 L=600	1	
8	X02.219.090	TUBO D.25 L= 900	PIPE D. 25 L=900	1	
9	X02.460.000	COPERCHIO FILETTATO FEMMINA	FEMALE THREADED TANK LID	1	
10	X02.293.000	RIDUZIONE 1" M - 3/4" M	1" M - 3/4" M REDUCER NIPPLE	1	
11	X00.055.021	RACCORDO DIRITTO PG D.25	STRAIGHT HOSE R.H D.25	1	
12	X00.055.24.2	GIRELLO 1" GAS	1" FLY NUT	1	
13	XOR.000.132	OR D.23,81 x 2,62	23,81 x 2,62 O-RING GASKET	1	
14	X40.298.000	SERBATOIO LAVAIMPIANTI LT. 25	RESERVOIR TANK LT. 25	1	
15	X02.403.000	RACCORDO DIRITTO PG D.25 - 1"	STRAIGHT HOSE R. H D.25 - 1"	2	
16	X02.219.100	TUBO D.25 L=1000	PIPE D.25 L=1000	1	
17	XF0.023.035I	FASCETTA A VITE 23/35 W4 INOX	STAINLESS STEEL CLIP	4	
18	X02.213.020	TUBETTO DI SFIATO D.10 L=200	BREATHER PIPE D.10 L=200	1	
19	X20.933.000	GUARNIZIONE SFIATO SERBATOIO	TANK BREATHER GASKET	2	

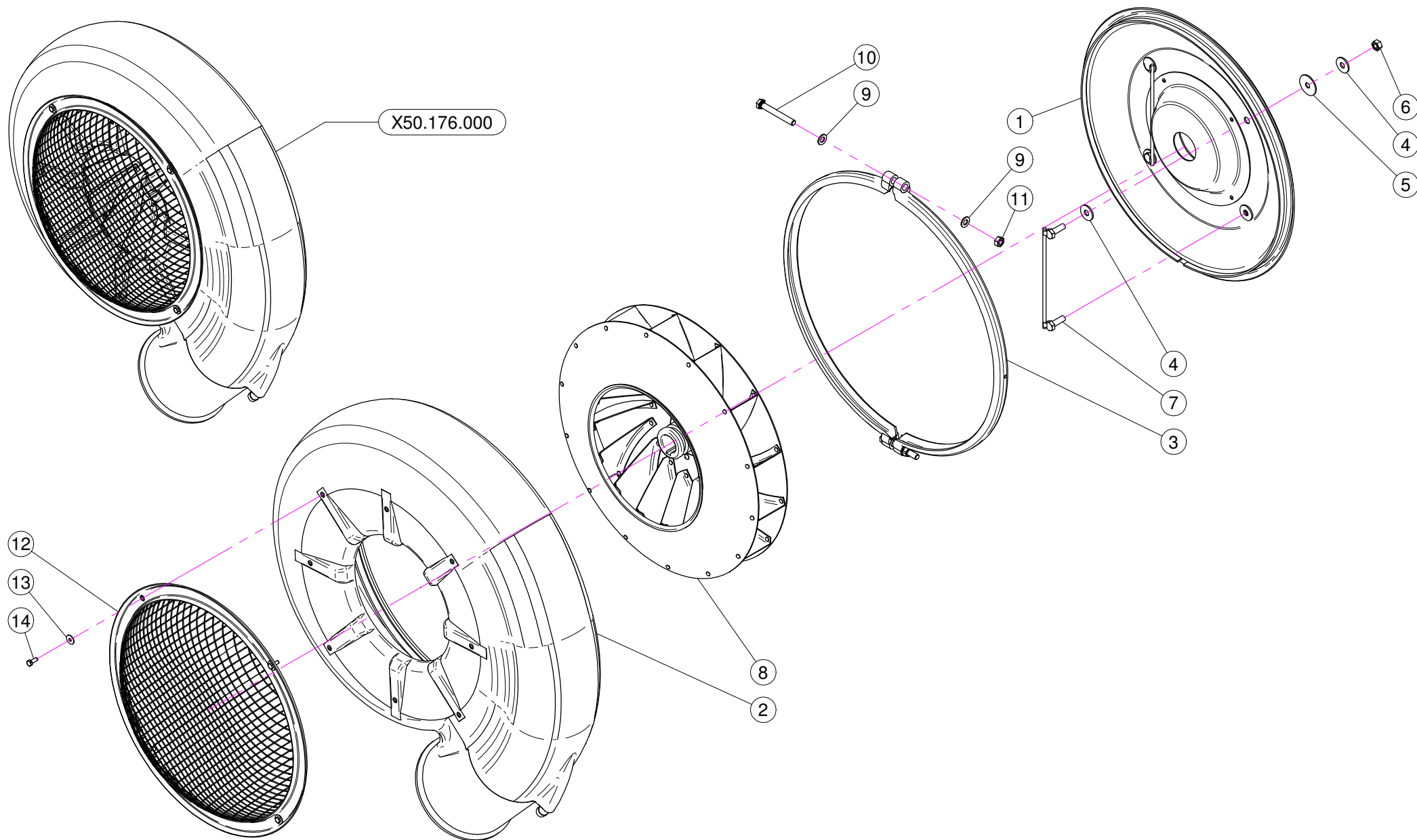

N°	Doc. Number	Titolo	Title	Q.tà	Note
1	X50.120.000	COPERCHIO VENTOLA 50	FAN 50 COVER	1	
2	X05.730.000	CARTER VENTOLA 50	50 FAN HAUSING	1	
3	X05.731.000.Z	COLLARE D.535	D.535 CLAMP	1	
4	XRP.010.030	RONDELLA PIANA D.10 x 30 mm	WASHER D.10 x 30 mm	8	
5	XRP.010.040	RONDELLA PIANA D.10 X 40	WASHER D.10 X 40	4	
6	XD0.10.5587G	DADO M10	NUT M10	4	
7	X20.088.000	CAVALLOTTO FISSAGGIO COPERCHIO POSTERIORE	BACK COVER BRACKET	2	
8	X05.732.000	VENTOLA 50	FAN 50	1	
9	XRP.010.000	RONDELLA PIANA D.10	WASHER D.10	4	
10	XTE.010.080T	VITE M10x80	M10x80 BOLT	2	
11	XDOT.10.5587	DADO OTTONE M10	M10 BRASS NUT	2	
12	X05.654.200	RETE PROTEZIONE VENTILATORE	FAN NET PROTECTION	1	
13	XRP.006.018	RONDELLA PIANA D. 6x18	WASHER D.6x18	4	
14	XTE.006.016T	VITE TE M6X16	SCREW TE M6X16	4	

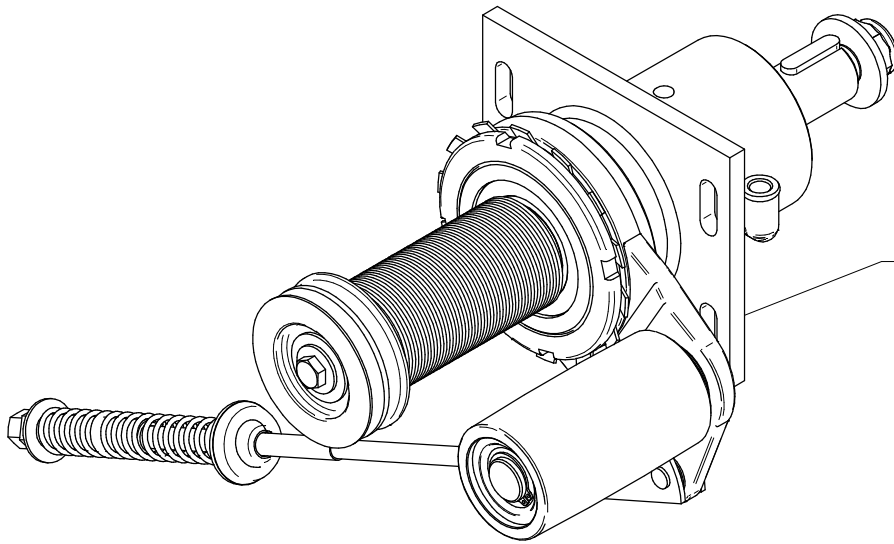

X50.133.000 Sez. 04 NORMAL

X50.138.000 Sez. 04 SUPER

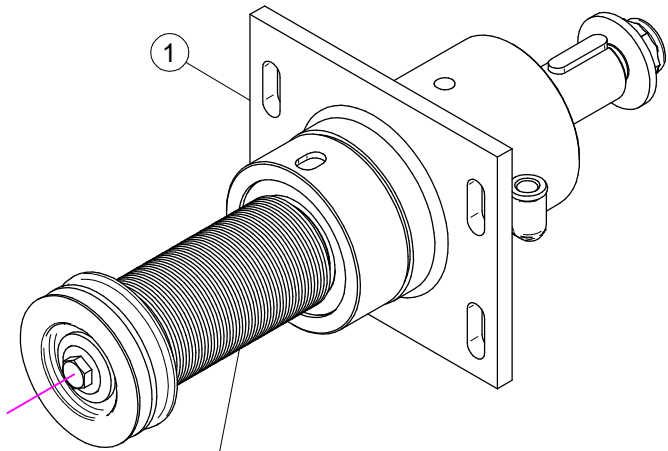

1

X50.132.000 Sez. 04A NORMAL

X50.137.000 Sez. 04A SUPER

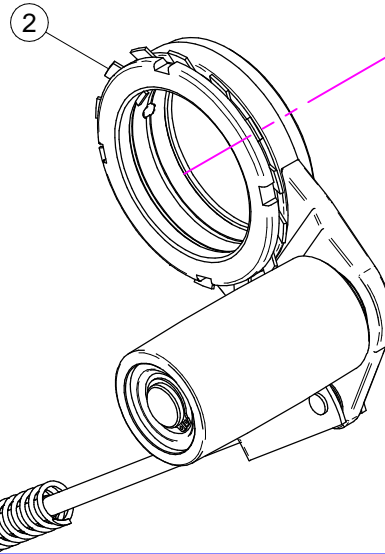

2

X05.707.001 Sez. 04B

X50.133.000 NORMAL

N°	Doc. Number	Titolo	Title	Q.tà	Note
1	X50.132.000	SUPPORTO OLIO 50 -PULEGGIA D.64,5 SENZA DISINNESTO	FAN SUPPORT WITH SHAFT - PUL D.64,5 NO DISENGAGEMENT	1	
2	X05.707.001	TENDICINGHIA AUTOMATICO COMPLETO	AUTOMATIC BELT STRETCHER	1	

X50.138.000 SUPER

N°	Doc. Number	Titolo	Title	Q.tà	Note
1	X50.137.000	SUPPORTO OLIO 50 -PULEGGIA D. 60 SENZA DISINNESTO	FAN SUPPORT WITH SHAFT - PUL D.60 NO DISENGAGEMENT	1	
2	X05.707.001	TENDICINGHIA AUTOMATICO COMPLETO	AUTOMATIC BELT STRETCHER	1	

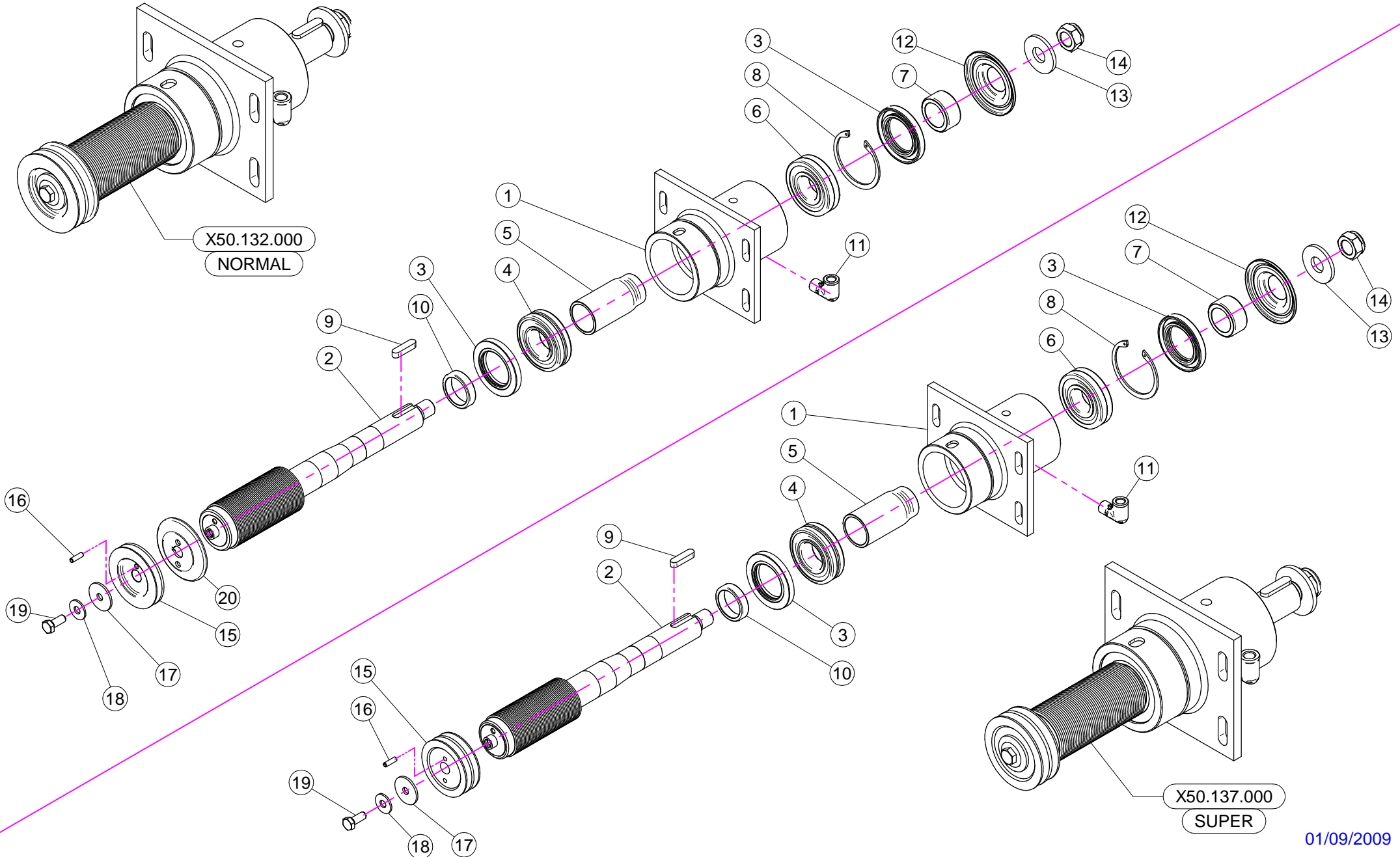

X50.132.000 NORMAL

N°	Doc. Number	Titolo	Title	Q.tà	Note
1	X50.110.000	SUPPORTO VENTILATORE NUDO	NUDE FAN SUPPORT	1	
2	X50.119.064,5	ALBERO CON PULEGGIA D. 64,5	SHAFT WITH PULLEY D.64,5	1	
3	XBASL.50.80.10	ANELLO DI TENUTA IN VITON (50-80-10)	VITON LIP SEALS -IEL (50-80-10)	2	
4	XK0.022.208	CUSCINETTO RULLI OBLIQUI 22-208	ROLLER BEARING 22-208	1	
5	X50.112.000	DISTANZIALE SUPP. VENTILATORE "OLIO"	SPACER	1	
6	XK0.021.307	CUSCINETTO RULLI OBLIQUI 21-307	ROLLER BEARING 21-307	1	
7	X50.113.000	DISTANZIALE TENUTA LATO VENTOLA	SPACER	1	
8	XI0.080.000	ANELLO ELASTICO INTERNO D.80	INTERNAL D.80 CIRCLIP	1	
9	XL.10.08.40	CHIAVETTA 10x8x40	FEATHER KEY 10x8x40	1	
10	X50.114.000	DISTANZIALE PER TENUTA LATO PULEGGIA	SPACER	1	
11	X20.789.000	GOMITO 90° TUBO DI CARICO OLIO	MALE/FEMALE 90° ELBOW	1	
12	X50.115.000	COPERCHIETTO LATO VENTOLA	DUST COVER	1	
13	X20.820.000	RONDELLA BLOCCAGGIO VENTOLA	WASHER	1	
14	XDA.022.0BF	DADO ESAGONALE M22 AUTOBLOCCANTE	SELF-LOCKING NUT M22 x 1,5	1	
15	X05.816.000	PULEGGIA COMANDO POMPA D.88 (1 x 3V)	PULLEY FOR PUMP D.88 (1x3V)	1	
16	XSE.006.020	SPINA ELASTICA D.6x20	SPRING PIN D.6x20	1	
17	XRP.010.040	RONDELLA PIANA D.10 X 40	WASHER D.10 X 40	1	
18	XRP.010.028	RONDELLA PIANA D.10 x 28 mm	WASHER D.10 x 28 mm	1	
19	XTE.010.025FT	VITE TE M10x25	BOLT TE M10x25	1	
20	X02.723.000A	SEMIPULEGGIA D.88	SEMIPULLEY D.88	1	

X50.137.000 SUPER

N°	Doc. Number	Titolo	Title	Q.tà	Note
1	X50.110.000	SUPPORTO VENTILATORE NUDO	NUDE FAN SUPPORT	1	
2	X50.119.060	ALBERO CON PULEGGIA D. 60	SHAFT WITH PULLEY D.60	1	
3	XBASL.50.80.10	ANELLO DI TENUTA IN VITON (50-80-10)	VITON LIP SEALS -IEL (50-80-10)	2	
4	XK0.022.208	CUSCINETTO RULLI OBLIQUI 22-208	ROLLER BEARING 22-208	1	
5	X50.112.000	DISTANZIALE SUPP. VENTILATORE "OLIO"	SPACER	1	
6	XK0.021.307	CUSCINETTO RULLI OBLIQUI 21-307	ROLLER BEARING 21-307	1	
7	X50.113.000	DISTANZIALE TENUTA LATO VENTOLA	SPACER	1	
8	XI0.080.000	ANELLO ELASTICO INTERNO D.80	INTERNAL D.80 CIRCLIP	1	
9	XL.10.08.40	CHIAVETTA 10x8x40	FEATHER KEY 10x8x40	1	
10	X50.114.000	DISTANZIALE PER TENUTA LATO PULEGGIA	SPACER	1	
11	X20.789.000	GOMITO 90° TUBO DI CARICO OLIO	MALE/FEMALE 90° ELBOW	1	
12	X50.115.000	COPERCHIETTO LATO VENTOLA	DUST COVER	1	
13	X20.820.000	RONDELLA BLOCCAGGIO VENTOLA	WASHER	1	
14	XDA.022.0BF	DADO ESAGONALE M22 AUTOBLOCCANTE	SELF-LOCKING NUT M22 x 1,5	1	
15	X05.746.000	PULEGGIA COMANDO POMPA D.82 2x3V	PULLEY FOR PUMP D.82 2x3V	1	
16	XSE.006.020	SPINA ELASTICA D.6x20	SPRING PIN D.6x20	1	
17	XRP.010.040	RONDELLA PIANA D.10 X 40	WASHER D.10 X 40	1	
18	XRP.010.028	RONDELLA PIANA D.10 x 28 mm	WASHER D.10 x 28 mm	1	
19	XTE.010.025FT	VITE TE M10x25	BOLT TE M10x25	1	

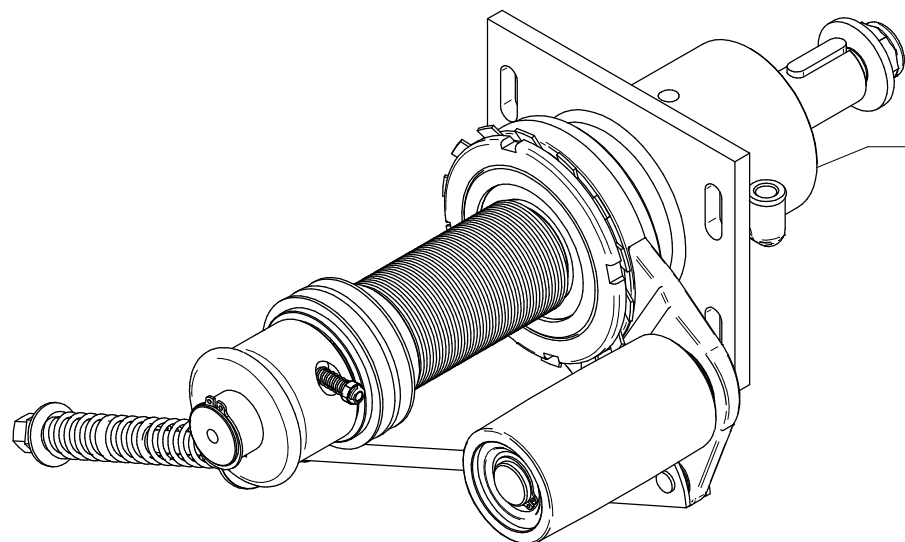

X50.124.000 Sez. 04 Plus / NORMAL

X50.127.000 Sez. 04 Plus / SUPER

X50.125.000 Sez. 04 Blitz - Blitz "A" - Link - Gp - Vb / NORMAL

X50.128.000 Sez. 04 Blitz - Blitz "A" - Link - Gp - Vb / SUPER

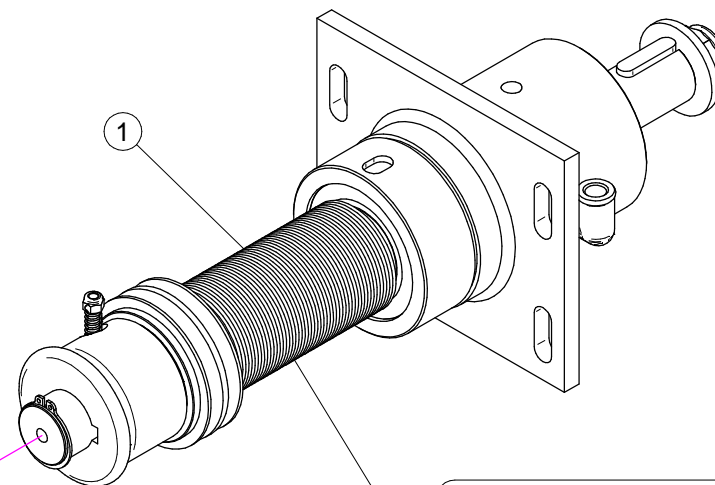

X50.123.000 Sez. 04A / NORMAL

X50.126.000 Sez. 04A / SUPER

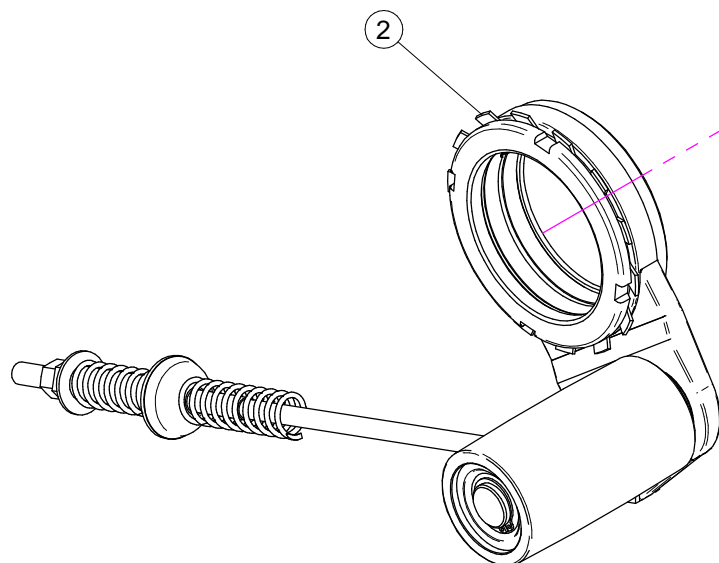

X05.707.000 Sez. 04B Plus

X05.707.001 Sez. 04B Blitz - Blitz "A" - Link - Gp - Vb

X50.124.000 NORMAL

N°	Doc. Number	Titolo	Title	Q.tà	Note
1	X50.123.000	SUPPORTO OLIO 50 - PUL. D.64,5 DISINNESTO	FAN SUPPORT WITH SHAFT - PUL D.64,5 DISENGANGEMENT	1	
2	X05.707.000	TENDICINGHIA AUTOMATICO COMPLETO	AUTOMATIC BELT STRETCHER	1	

X50.127.000 SUPER

N°	Doc. Number	Titolo	Title	Q.tà	Note
1	X50.126.000	SUPPORTO OLIO 50 - PUL. D. 60 DISINNESTO	FAN SUPPORT WITH SHAFT -PUL D. 60 DISENGANGEMENT	1	
2	X05.707.000	TENDICINGHIA AUTOMATICO COMPLETO	AUTOMATIC BELT STRETCHER	1	

X50.125.000 NORMAL

N°	Doc. Number	Titolo	Title	Q.tà	Note
1	X50.123.000	SUPPORTO OLIO 50 - PUL. D.64,5 DISINNESTO	FAN SUPPORT WITH SHAFT - PUL D.64,5 DISENGANGEMENT	1	
2	X05.707.001	TENDICINGHIA AUTOMATICO COMPLETO	AUTOMATIC BELT STRETCHER	1	

X50.128.000 SUPER

N°	Doc. Number	Titolo	Title	Q.tà	Note
1	X50.126.000	SUPPORTO OLIO 50 - PUL. D. 60 DISINNESTO	FAN SUPPORT WITH SHAFT -PUL D. 60 DISENGANGEMENT	1	
2	X05.707.001	TENDICINGHIA AUTOMATICO COMPLETO	AUTOMATIC BELT STRETCHER	1	

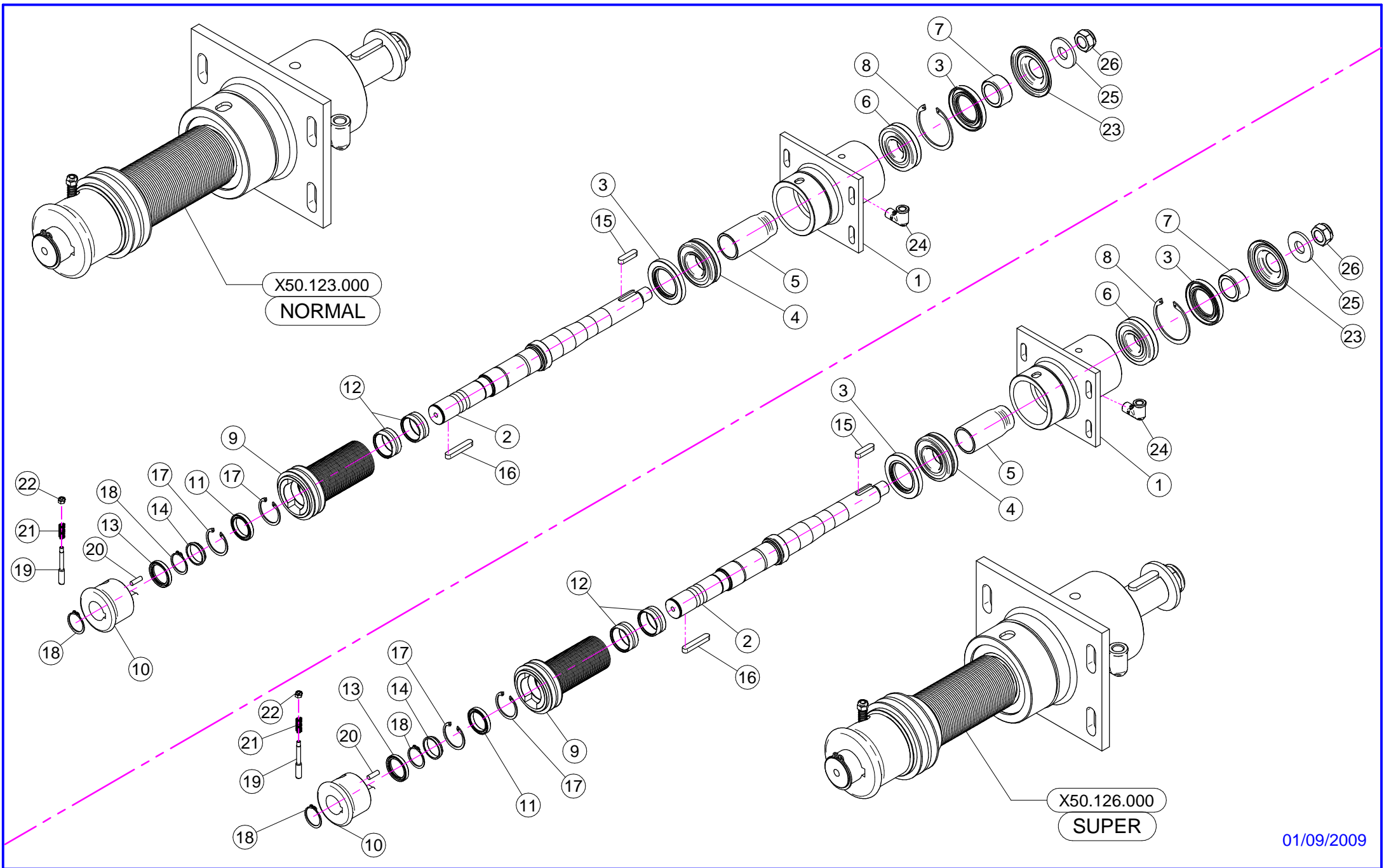

X50.123.000 NORMAL

N°	Doc. Number	Titolo	Title	Q.tà	Note
1	X50.110.000	SUPPORTO VENTILATORE NUDO	NUDE FAN SUPPORT	1	
2	X50.111.000	ALBERO VENTILATORE	SHAFT	1	
3	XBASL.50.80.10	ANELLO DI TENUTA IN VITON (50-80-10)	VITON LIP SEALS -IEL (50-80-10)	2	
4	XK0.022.208	CUSCINETTO RULLI OBLIQUI 22-208	ROLLER BEARING 22-208	1	
5	X50.112.000	DISTANZIALE SUPP. VENTILATORE "OLIO"	SPACER	1	
6	XK0.021.307	CUSCINETTO RULLI OBLIQUI 21-307	ROLLER BEARING 21-307	1	
7	X50.113.000	DISTANZIALE TENUTA LATO VENTOLA	SPACER	1	
8	XI0.080.000	ANELLO ELASTICO INTERNO D.80	INTERNAL D.80 CIRCLIP	1	
9	X05.968.064,5	PULEGGIA D. 64,5 J 50 PER DISINNESTO	PULLEY D.64,5 J50	1	
10	X05.641.000	DISINNESTO NUDO	NUDE DISENGAGEMENT	1	
11	XK0.061.807.EE	CUSCINETTO 61807-EE	BEARING 61807-EE	1	
12	XK0.HK4.020.EE	CUSCINETTO A RULLINI SENZA GABBIA	NEEDLE BEARING WITHOUT CAGE	2	
13	XBASL.35.47.07	ANELLO DI TENUTA 35 x 47 x 7	LIP SEAL 35 x 47 x 7	1	
14	X05.642.000	DISTANZIALE PULEGGIA DISINNESTO	SPACER	1	
15	XL.10.08.40	CHIAVETTA 10x8x40	FEATHER KEY 10x8x40	1	
16	XL.10.08.60	CHIAVETTA BLOCCAGGIO 10x8x60	FEATHER KEY 10x8x60	1	
17	XI0.047.000	ANELLO ELASTICO INTERNO D.47	INTERNAL D.47 CIRCLIP	2	
18	XE0.035.000	ANELLO ELASTICO ESTERNO D.35	EXTERNAL D.35 CIRCLIP	2	
19	X04.705.000	PULSANTE PER DISINNESTO	PUSH FOR DISENGAGEMENT	1	
20	X04.881.022,5	AMMORTIZZATORE CILINDRICO DISINNESTO	VULCOLAN RELEASE SHOCK	4	
21	X02.502.001	MOLLA A COMPRESSIONE	SPRING	1	
22	XDA.006.0AG	DADO AUTOBLOCCANTE M6	SELF LOCKING NUT M6	1	
23	X50.115.000	COPERCHIETTO LATO VENTOLA	DUST COVER	1	
24	X20.789.000	GOMITO 90° TUBO DI CARICO OLIO	MALE/FEMALE 90° ELBOW	1	
25	X20.820.000	RONDELLA BLOCCAGGIO VENTOLA	WASHER	1	
26	XDA.022.0BF	DADO ESAGONALE M22 AUTOBLOCCANTE	SELF-LOCKING NUT M22 x 1,5	1	

X50.126.000 SUPER

N°	Doc. Number	Titolo	Title	Q.tà	Note
1	X50.110.000	SUPPORTO VENTILATORE NUDO	NUDE FAN SUPPORT	1	
2	X50.111.000	ALBERO VENTILATORE	SHAFT	1	
3	XBASL.50.80.10	ANELLO DI TENUTA IN VITON (50-80-10)	VITON LIP SEALS -IEL (50-80-10)	2	
4	XK0.022.208	CUSCINETTO RULLI OBLIQUI 22-208	ROLLER BEARING 22-208	1	
5	X50.112.000	DISTANZIALE SUPP. VENTILATORE "OLIO"	SPACER	1	
6	XK0.021.307	CUSCINETTO RULLI OBLIQUI 21-307	ROLLER BEARING 21-307	1	
7	X50.113.000	DISTANZIALE TENUTA LATO VENTOLA	SPACER	1	
8	XI0.080.000	ANELLO ELASTICO INTERNO D.80	INTERNAL D.80 CIRCLIP	1	
9	X05.968.060	PULEGGIA D. 60 J PER DISINNESTO	PULLEY D.60 J	1	
10	X05.641.000	DISINNESTO NUDO	NUDE DISENGAGEMENT	1	
11	XK0.061.807.EE	CUSCINETTO 61807-EE	BEARING 61807-EE	1	
12	XK0.HK4.020.EE	CUSCINETTO A RULLINI SENZA GABBIA	NEEDLE BEARING WITHOUT CAGE	2	
13	XBASL.35.47.07	ANELLO DI TENUTA 35 x 47 x 7	LIP SEAL 35 x 47 x 7	1	
14	X05.642.000	DISTANZIALE PULEGGIA DISINNESTO	SPACER	1	
15	XL.10.08.40	CHIAVETTA 10x8x40	FEATHER KEY 10x8x40	1	
16	XL.10.08.60	CHIAVETTA BLOCCAGGIO 10x8x60	FEATHER KEY 10x8x60	1	
17	XI0.047.000	ANELLO ELASTICO INTERNO D.47	INTERNAL D.47 CIRCLIP	2	
18	XE0.035.000	ANELLO ELASTICO ESTERNO D.35	EXTERNAL D.35 CIRCLIP	2	
19	X04.705.000	PULSANTE PER DISINNESTO	PUSH FOR DISENGAGEMENT	1	
20	X04.881.022,5	AMMORTIZZATORE CILINDRICO DISINNESTO	VULCOLAN RELEASE SHOCK	4	
21	X02.502.001	MOLLA A COMPRESSIONE	SPRING	1	
22	XDA.006.0AG	DADO AUTOBLOCCANTE M6	SELF LOCKING NUT M6	1	
23	X50.115.000	COPERCHIETTO LATO VENTOLA	DUST COVER	1	
24	X20.789.000	GOMITO 90° TUBO DI CARICO OLIO	MALE/FEMALE 90° ELBOW	1	
25	X20.820.000	RONDELLA BLOCCAGGIO VENTOLA	WASHER	1	
26	XDA.022.0BF	DADO ESAGONALE M22 AUTOBLOCCANTE	SELF-LOCKING NUT M22 x 1,5	1	

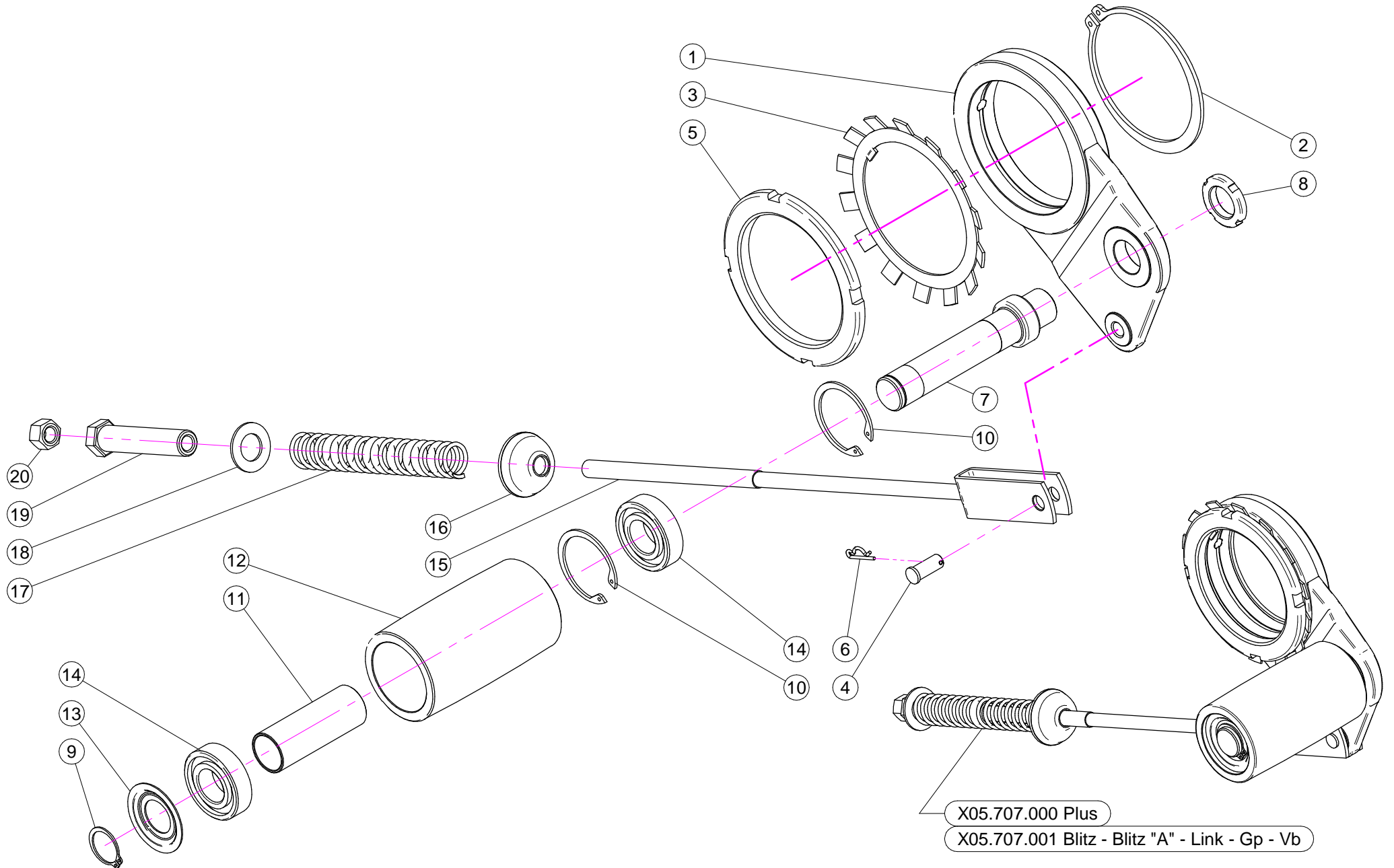

X05.707.000 PLUS

N°	Doc. Number	Titolo	Title	Q.tà	Note
1	X05.696.000	SUPPORTO PER TENDICINGHIA AUTOMATICO	IDLER SUPPORT	1	
2	XE0.100.000	ANELLO ELASTICO ESTERNO D.100	EXTERNAL D. 100 CIRCLIP	1	
3	XMB.020.000	ROSETTA DI SICUREZZA MB 20	TOOTH LOCK WASHER	1	
4	X04.593.000	PERNO FORCELLA TENDICINGHIA	PIN	1	
5	X05.704.000	GHIERA DI REGISTRO M100 X 2	REGISTER NUT	1	
6	X00.100.002	COPIGLIA	CLIP	1	
7	X05.697.000	PERNO TENDICINGHIA AUTOMATICO	PIVOT	1	
8	XKM.005.000	GHIERA KM5	NUT KM5	1	
9	XE0.025.000	ANELLO ELASTICO ESTERNO D. 25	EXTERNAL D. 25 CIRCLIP	1	
10	XI0.052.000	ANELLO ELASTICO INTERNO D. 52	INTERNAL D. 52 CIRCLIP	2	
11	X05.631.101	DISTANZIALE TENDICINGHIA AUTOMATICO	SPACER	1	
12	X05.630.000	RULLO PER TENDICINGHIA AUTOMATICO	ROLLER	1	
13	X04.585.000	COPERCHIO PARAPOLVERE TENDICINGHIA	ANTI - DUST COVER	1	
14	XK6.205.2RS	CUSCINETTO 6205-2RS	ROLLER BEARING 6205-2RS	2	
15	X05.726.000	FORCELLA TENSIONE TENDICINGHIA	BELT STRETCHER FORK	1	*
16	X20.260.000	RONDELLA BOMBATA D.12 PER TENDICINGHIA	SPECIAL WASHER D.12	1	
17	X04.093.000	MOLLA TENDICINGHIA AUTOMATICO	SPRING	1	
18	XRP.019.000	RONDELLA PIANA D.19 6592	WASHER D.19	1	
19	X04.583.000	VITE SPECIALE MOLLA TENDICINGHIA	SPECIAL SCREW	1	
20	XD0.12.5587G	DADO M12 PG UNI 5587	M12 NUT	1	

X05.707.001 BLITZ - BLITZ "A" - LINK - GP - VB

N°	Doc. Number	Titolo	Title	Q.tà	Note
1	X05.696.000	SUPPORTO PER TENDICINGHIA AUTOMATICO	IDLER SUPPORT	1	
2	XE0.100.000	ANELLO ELASTICO ESTERNO D.100	EXTERNAL D. 100 CIRCLIP	1	
3	XMB.020.000	ROSETTA DI SICUREZZA MB 20	TOOTH LOCK WASHER	1	
4	X04.593.000	PERNO FORCELLA TENDICINGHIA	PIN	1	
5	X05.704.000	GHIERA DI REGISTRO M100 X 2	REGISTER NUT	1	
6	X00.100.002	COPIGLIA	CLIP	1	
7	X05.697.000	PERNO TENDICINGHIA AUTOMATICO	PIVOT	1	
8	XKM.005.000	GHIERA KM5	NUT KM5	1	
9	XE0.025.000	ANELLO ELASTICO ESTERNO D. 25	EXTERNAL D. 25 CIRCLIP	1	
10	XI0.052.000	ANELLO ELASTICO INTERNO D. 52	INTERNAL D. 52 CIRCLIP	2	
11	X05.631.101	DISTANZIALE TENDICINGHIA AUTOMATICO	SPACER	1	
12	X05.630.000	RULLO PER TENDICINGHIA AUTOMATICO	ROLLER	1	
13	X04.585.000	COPERCHIO PARAPOLVERE TENDICINGHIA	ANTI - DUST COVER	1	
14	XK6.205.2RS	CUSCINETTO 6205-2RS	ROLLER BEARING 6205-2RS	2	
15	X05.653.000	FORCELLA TENSIONE TENDICINGHIA	BELT TRETCHER FORK	1	*
16	X20.260.000	RONDELLA BOMBATA D.12 PER TENDICINGHIA	SPECIAL WASHER D.12	1	
17	X04.093.000	MOLLA TENDICINGHIA AUTOMATICO	SPRING	1	
18	XRP.019.000	RONDELLA PIANA D.19 6592	WASHER D.19	1	
19	X04.583.000	VITE SPECIALE MOLLA TENDICINGHIA	SPECIAL SCREW	1	
20	XD0.12.5587G	DADO M12 PG UNI 5587	M12 NUT	1	

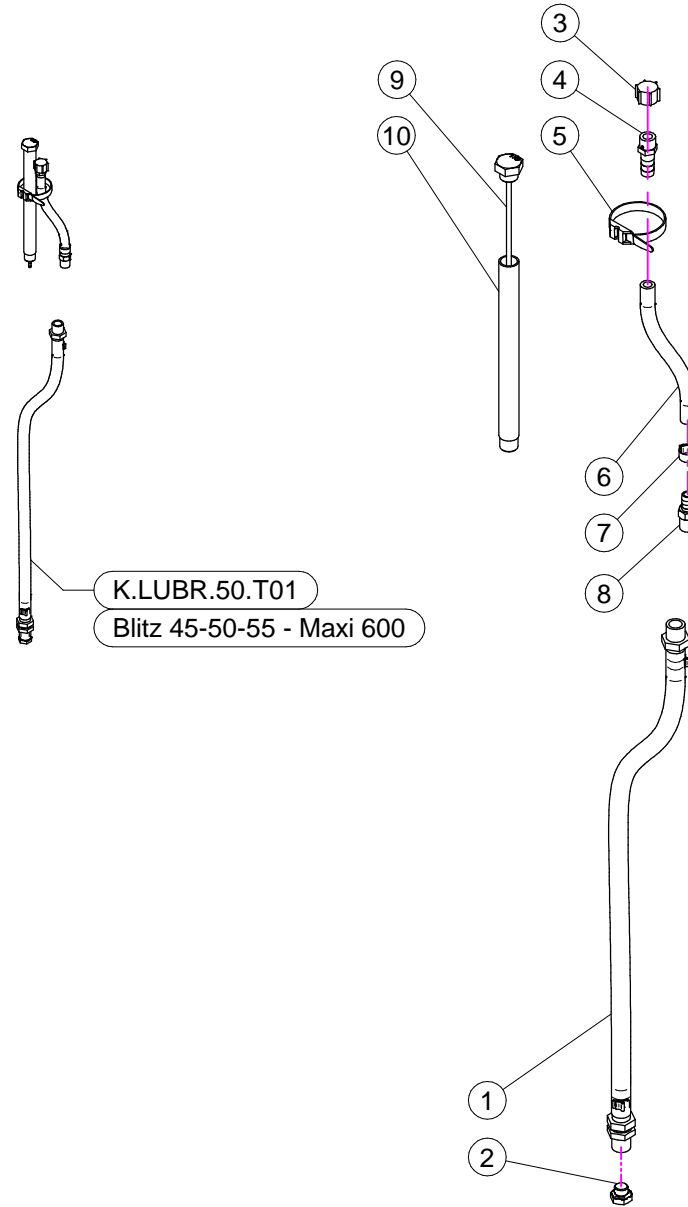
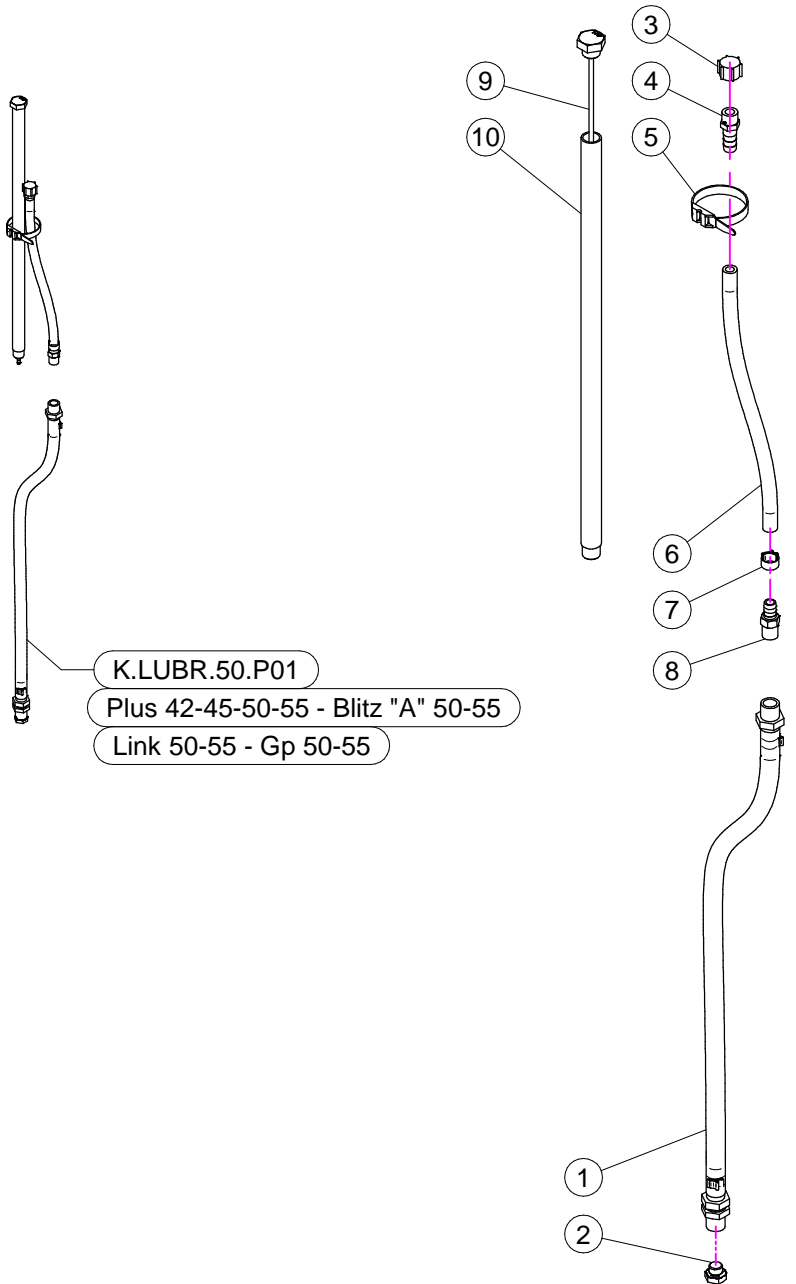

K.LUBR.50.P01 (Plus 42-45-50-55 - Blitz "A" 50-55 - Link 50-55 - Gp 50-55)

N°	Doc. Number	Titolo	Title	Q.tà	Note
1	X20.790.000	TUBO DI SCARICO OLIO 3/8" CIL. - 3/8" CON.	DRAIN PIPE 3/8"	1	
2	X40.266.000	TAPPO SCARICO OLIO M12x1,5	OIL EXAUSTPLUG	1	
3	X02.013.000	TAPPO CIMA G 1/4" F.	PLUG G 1/4"	1	
4	X00.414.100	PORTAGOMMA D.11 1/4" M. FORATO	STRAIGHT HOSE D.11 1/4" WITH BLEED	1	
5	X02.355.000	FASCETTA D'ASSEMBLAGGIO 235 mm	NYLON ASSEMBLY CLAMP	1	
6	X02.217.025	TUBO D. 8x13 L= 250	HOSE D. 8x13 L= 250	1	
7	XFC.014,5.016	FASCETTA COBRA SLO30716	KOBRA CLAMP	1	
8	X20.792.000	PORTAGOMMA D.11 G 1/4" M. PER SFIATO	STRAIGHT HOSE D.11 G 1/4" FOR BREATHER	1	
9	X50.116.000	TAPPO CON ASTA LIVELLO OLIO L=465	FILLING PLUG WITH DIPSTICK	1	
10	X50.122.000	TUBO DI CARICO OLIO L=451	FILLING PIPE L=451	1	

K.LUBR.50.T01 (Blitz 45-50-55 - Maxi 600)

N°	Doc. Number	Titolo	Title	Q.tà	Note
1	X20.790.000	TUBO DI SCARICO OLIO 3/8" CIL. - 3/8" CON.	DRAIN PIPE 3/8"	1	
2	X40.266.000	TAPPO SCARICO OLIO M12x1,5	OIL EXAUSTPLUG	1	
3	X02.013.000	TAPPO CIMA G 1/4" F.	PLUG G 1/4"	1	
4	X00.414.100	PORTAGOMMA D.11 1/4" M. FORATO	STRAIGHT HOSE D.11 1/4" WITH BLEED	1	
5	X02.355.000	FASCETTA D'ASSEMBLAGGIO 235 mm	NYLON ASSEMBLY CLAMP	1	
6	X02.217.015	TUBO D. 8x13 L= 150	HOSE D. 8x13 L= 150	1	
7	XFC.014,5.016	FASCETTA COBRA SLO30716	KOBRA CLAMP	1	
8	X20.792.000	PORTAGOMMA D.11 G 1/4" M. PER SFIATO	STRAIGHT HOSE D.11 G 1/4" FOR BREATHER	1	
9	X40.269.000	TAPPO CON ASTA LIVELLO OLIO L=215	FILLIG PLUG WITH DIPSTICK L=215	1	
10	X40.272.000	TUBO CARICAMENTO L=201	FILLING PIPE L=201	1	

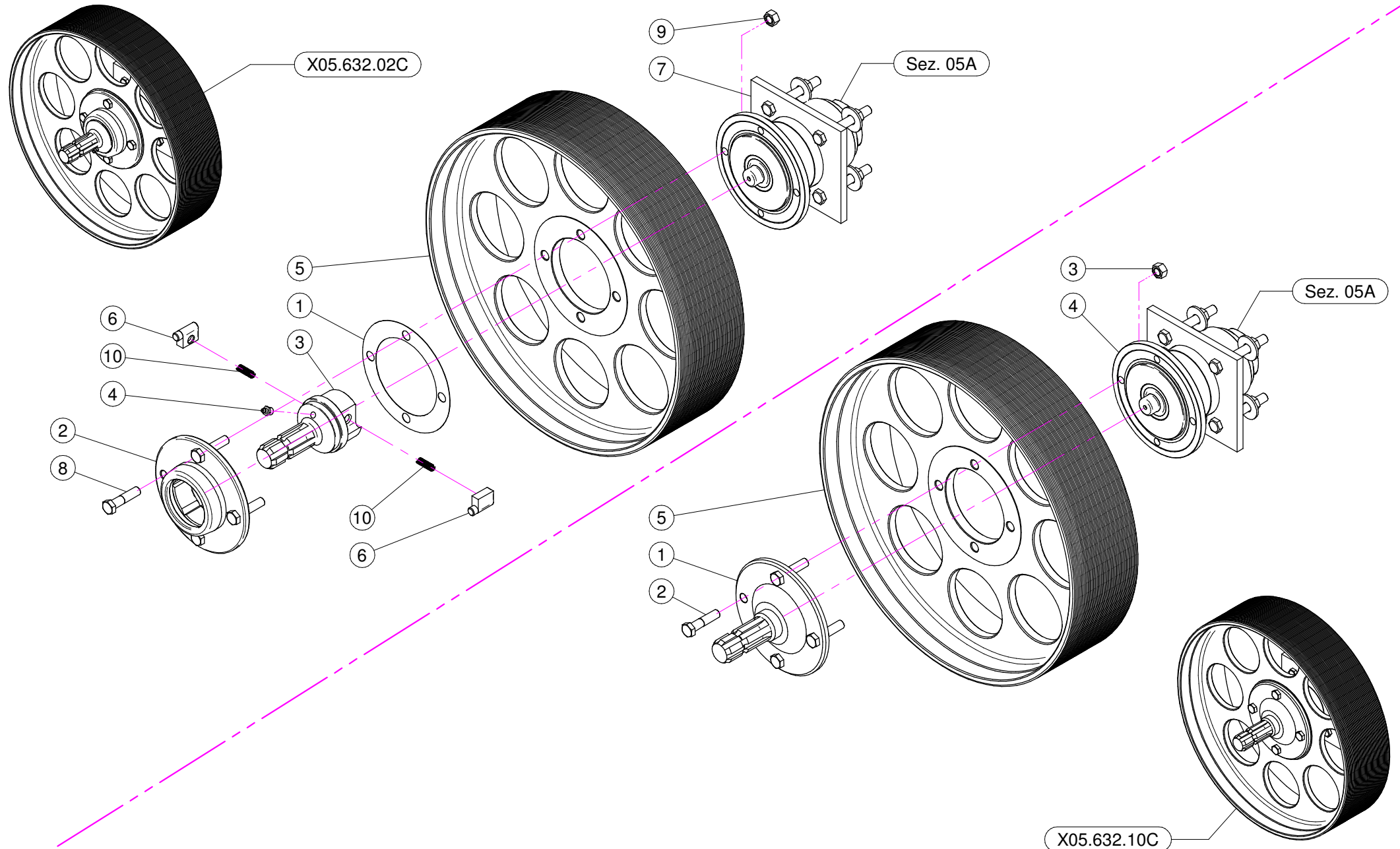

X05.632.02C

N°	Doc. Number	Titolo	Title	Q.tà	Note
1	X04.719.000	GUARNIZIONE RUOTA LIBERA	GASKET	1	
2	X04.066.000	CORPO ESTERNO RUOTA LIBERA	BODY	1	
3	X03.701.000	ROTORE RUOTA LIBERA	ROTOR	1	
4	XID.010.001	INGRASSATORE DIRITTO M10X1	GREASE NIPPLE	1	
5	X00.480.J50	PULEGGIA DIAM. 480 J 50	PULLEY DIAM. 480 J 50	1	
6	X02.502.002	MARTELLETTO RUOTA LIBERA	PIN	2	
7	X05.632.01C	SUPPORTO INFERIORE 50 / 55 D	CLUTCH	1	
8	XTE.012.050F	VITE TE M12X50	BOLT M12X50	4	
9	XDO.12.5587F	DADO M12 PG 5587F	NUT M12 PG 5587F	4	
10	X02.502.001	MOLLA A COMPRESSIONE	SPRING	2	

X05.632.10C

N°	Doc. Number	Titolo	Title	Q.tà	Note
1	X04.707.100	ALBERO SCANALATO PER P.D.P.	SHAFT	1	
2	XTE.012.050F	VITE TE M12X50	BOLT M12X50	4	
3	XDO.12.5587F	DADO M12 PG 5587F	NUT M12 PG 5587F	4	
4	X05.632.01C	SUPPORTO INFERIORE 50 / 55 D	CLUTCH	1	
5	X00.480.J50	PULEGGIA DIAM. 480 J 50	PULLEY DIAM. 480 J 50	1	

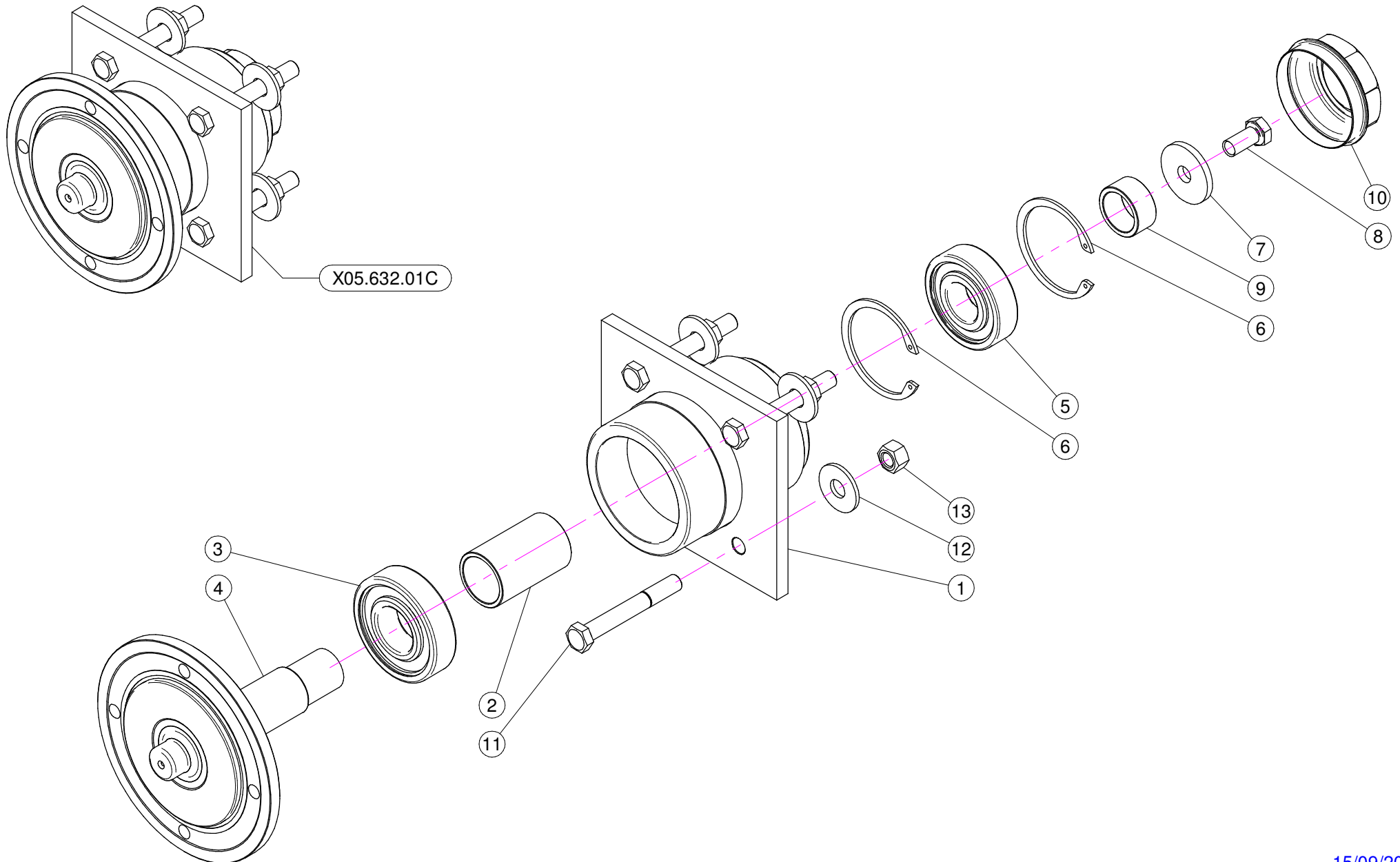

N°	Doc. Number	Titolo	Title	Q.tà	Note
1	X05.632.000	SUPPORTO INFERIORE	LOWER SUPPORT	1	
2	X04.565.000	DISTANZIALE PER ALBERO INFERIORE	LOWER SHAFT SPACING BAR	1	
3	XK6.307.2RS	CUSCINETTO	BEARING	1	
4	X04.589.000	ALBERO INFERIORE	LOWER SHAFT	1	
5	XK6.306.2RS	CUSCINETTO	BEARING	1	
6	XI0.072.000	ANELLO ELASTICO INTERNO D.72	SPACING BAR	2	
7	X20.810.000	RONDELLA SPECIALE PER SUPPORTO INFERIORE	SPECIAL WASHER FOR LOWER SUPPORT	1	
8	XTE.012.025FT	VITE TE 12X25	BOLT TE M12X1.25	1	
9	X04.590.000	DISTANZIALE PER ALBERO INFERIORE	SPACER	1	
10	X04.555.001	COPERCHIETTO DI CHIUSURA	COVER	1	
11	XTE.012.090	VITE TE M12 x 90	SCREW TE M12 x 90	4	
12	XRP.012.036	RONDELLA PIANA D12 X 36	WASHER D12 X 36	4	
13	XD0.12.5587G	DADO M12 PG UNI 5587	M12 NUT	4	

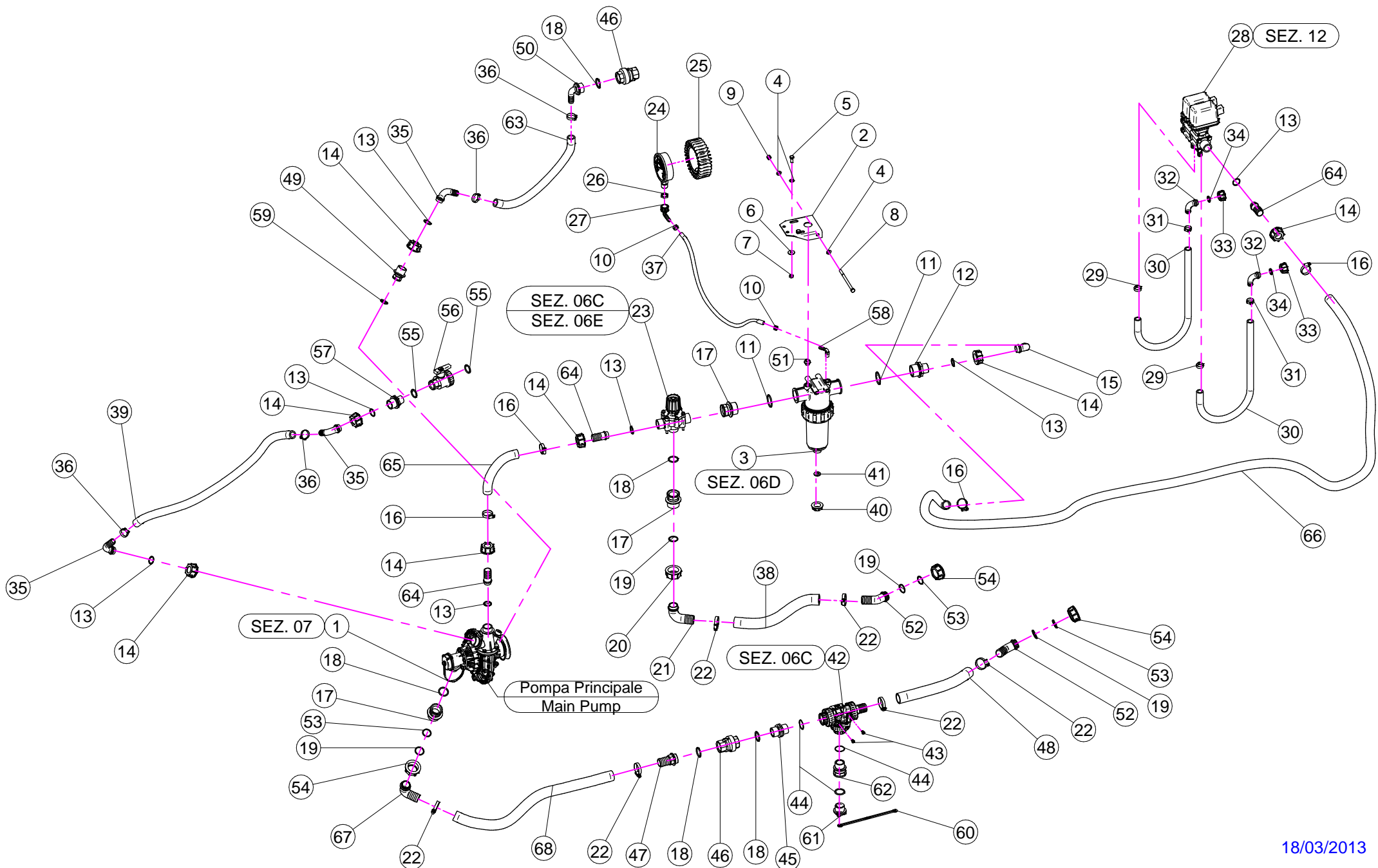

N°	Doc. Number	Titolo	Title	Q.tà	N°	Doc. Number	Titolo	Title	Q.tà
1	X02.157.071	POMPA COMPLETA	PUMP	1	35	X00.055.038	RACCORDO CURVO A P.G. D.19	CURVED UNION WITH R.H. D.19	3
2	X20.519.100	STAFFA FISSAGGIO GRUPPO REGOLAZIONE	BRACKET	1	36	XFC.027.5.029	FASCETTA COBRA 27,08 - W8	KOBRA CLAMP 27,08 - W8	4
3	X02.450.110	FILTRO IN LINEA F. 1" 1/4	LINE FILTER 1" 1/4 FEMALE	1	37	X02.217.040	TUBO D. 8x13 L= 400	HOSE D. 8x13 L= 400	1
4	XRP.008.000	RONDELLA PIANA D.8	WASHER D.8	4	38	X02.238.055	TUBO D. 30x41 L= 550	HOSE D. 30x41 L= 550	1
5	XTE.008.025T	VITE TE 8X25	SCREW TE M8X25	2	39	X02.212.100	TUBO D. 19x28 L= 1000	HOSE D. 19x28 L= 1000	1
6	XRP.008.024	RONDELLA PIANA LARGA D.8X24	WASHER D.8X24	2	40	X02.182.000	TAPPO 3/4" FEMMINA	FEMALE 3/4" CAP	1
7	XD0.08.5588G	DADO M8 6S PG	M8 6S BIG LEAD NUT 5588	2	41	X02.030.010	GUARNIZIONE TAPPO DISTRIBUTORE	GASKET	1
8	XTE.008.130	VITE TE M8 x 130	SCREW M8 x 130	1	42	X21.058.300	VALVOLA 3 VIE A SFERA CON 1 PG D.30	THREE WAYS VALVE	1
9	XDA.008.0AG	DADO AUTOBLOCCANTE M8	SELF LOCKING NUT M8	1	43	XTA.006.012P	VITI PER MAT. PLASTICI M6 x 12	SCREW M6 x 12	2
10	XFC.013.5.015	FASCETTA COBRA SLO30710	KOBRA CLAMP	2	44	XOR.002.125	OR D.31,47 x 1,78	31,47 x 1,78 O-RING GASKET	2
11	XOR.000.144	OR D.39,69x3,53	O-RING D.39,69x3,53	2	45	X00.055.034	NIPPLO 1" / 1" GAS	NIPPLE 1" / 1" GAS	1
12	X00.045.012	RIDUZIONE 1" 1/4 M - 1" M	1" 1/4 M - 1" M REDUCER NIPPLE	1	46	X21.149.000	VALVOLA DI RITEGNO 1" F.-F.	VALVE 1" F.-F.	2
13	XOR.000.132	OR D.23,81 x 2,62	23,81 x 2,62 O-RING GASKET	7	47	X00.422.100	RACCORDO DIRITTO PG 30 FIL.1" GAS TORNITO	MALE CONNECTOR RH 30 1" GAS	1
14	X00.055.24.2	GIRELLO 1" GAS	1" FLY NUT	7	48	X02.238.120	TUBO D. 30x38 L= 1200	HOSE D. 30x38 L= 1200	1
15	X00.055.037	RACCORDO CURVO P.G. D.25	D.25 HOSETAIL	1	49	X21.186.000	RIDUZIONE 1" M - 1/2" F	REDUCER NIPPLE 1" M - 1/2" F	1
16	XF0.023.035I	FASCETTA A VITE 23/35 W4 INOX	STAINLESS STEEL CLIP	4	50	X21.193.000	RACCORDO CURVO 90° 1" P.G.	HOSETAIL 90° 1" R.H.	1
17	X02.374.000	RIDUZIONE M/F 1" F / 1"1/4M	M. / F. 1" F / 1"1/4M REDUCTION	3	51	XTM.014.000	TAPPO MASCHIO 1/4"	MALE PLUG 1/4"	1
18	XOR.004.118	OR D.29,75 x 3,53	29,75 x 3,53 O-RING GASKET	6	52	X02.339.000	RACCORDO CURVO A 45° CON P.G. D.30	45° HOSETAIL	2
19	XOR.003.112	OR D.28,24x2,62	O-RING D.28,24x2,62	4	53	XOR.003.106	OR D.26.65x2.62	O-RING D.26.65x2.62	3
20	X00.058.006	GIRELLO 1" 1/4 GAS	1" 1/4 FLY NUT	1	54	X00.493.000	GIRELLO 1" 1/4 GAS	1" 1/4 FLY NUT	3
21	X00.058.004	RACCORDO CURVO P.G. D.30	D.30 HOSETAIL	1	55	XOR.000.134	OR D.25,8x3,53	O-RING D.25,8x3,53	2
22	XF0.025.040I	FASCETTA A VITE 25/40 W4 INOX	STAINLESS STEEL CLIP	6	56	X02.395.000	RUBINETTO 3/4" GAS F.F. SFERA	VALVE 3/4" GAS F.F. BALL	1
23	X02.447.000	VALVOLA A 3 VIE	3 WAY VALVE	1	57	X02.293.000	RIDUZIONE 1" M - 3/4" M	1" M - 3/4" M REDUCER NIPPLE	1
24	X02.445.000	MANOMETRO D.100 INOX 0-6 BAR	PRESSURE GAUGE Ø100 INOX 0-6 BAR	1	58	X21.084.000	RACCORDO 90° WES 8 / R1/4	HOSETAIL 90° WES 8 / R1/4	1
25	X02.470.000	CUFFIA PER MANOMETRO D.100	PRESSURE GAUGE GUARD	1	59	XOR.004.081	OR D.20,22 x 3,53	20,22 x 3,53 O-RING GASKET	1
26	X24.072.000	GHIERA IN OTTONE 1/2"	BRASS FLY NUT 1/2"	1	60	X21.183.000	STRISCIA FERMATAPPI	CAP STOP	1
27	X21.012.000	RACCORDO CURVO PG D. 12 G. 1/2"	D. 12 HOSETAIL	1	61	X21.182.000	TAPPO 1" M	PACKING 1" M	1
28	X02.390.08C	ELETTROVALVOLE	ELECTROVALVES	1	62	X02.384.000	RIDUZIONE 1" M - 1" F	1" M - 1" F REDUCER NIPPLE	1
29	XFC.021.5.023	FASCETTA COBRA 21,5 - 23	KOBRA CLAMP 21,5 - 23	2	63	X02.212.100	TUBO D. 19 L= 1000	HOSE D. 19 L= 1000	1
30	X02.211.110	TUBO D.16 L=1100	HOSE D.16 L=1100	2	64	X00.055.021	RACCORDO DIRITTO PG D.25	STRAIGHT HOSE R.H. D.25	3
31	XFC.023.5.025	FASCETTA COBRA 23,5 - 25	KOBRA CLAMP 23,5 - 25	2	65	X20.809.026	TUBO D.25x32 CON RAMINO L=260	HOSE D.25x32 L=260	1
32	X00.055.046	RACCORDO CURVO P.G. D.17	CURVED UNION WITH R.H. D.17	2	66	X20.770.287	TUBO SPIRALATO D.25 L=2870	HOSE D.25 L=2870	1
33	X00.055.045	GIRELLO 3/4" GAS	3/4" FLY NUT	2	67	X00.483.000	RACCORDO CURVO PG 30 1-1/4"	D.30 1-1/4" HOSETAIL	1
34	X02.349.000	GUARNIZIONE PIANA D.17X23X3	17X23X3 FLAT GASKET	2	68	X20.852.070	TUBO D.30 CON RAMINO L=700	HOSE D.30 L=700	1

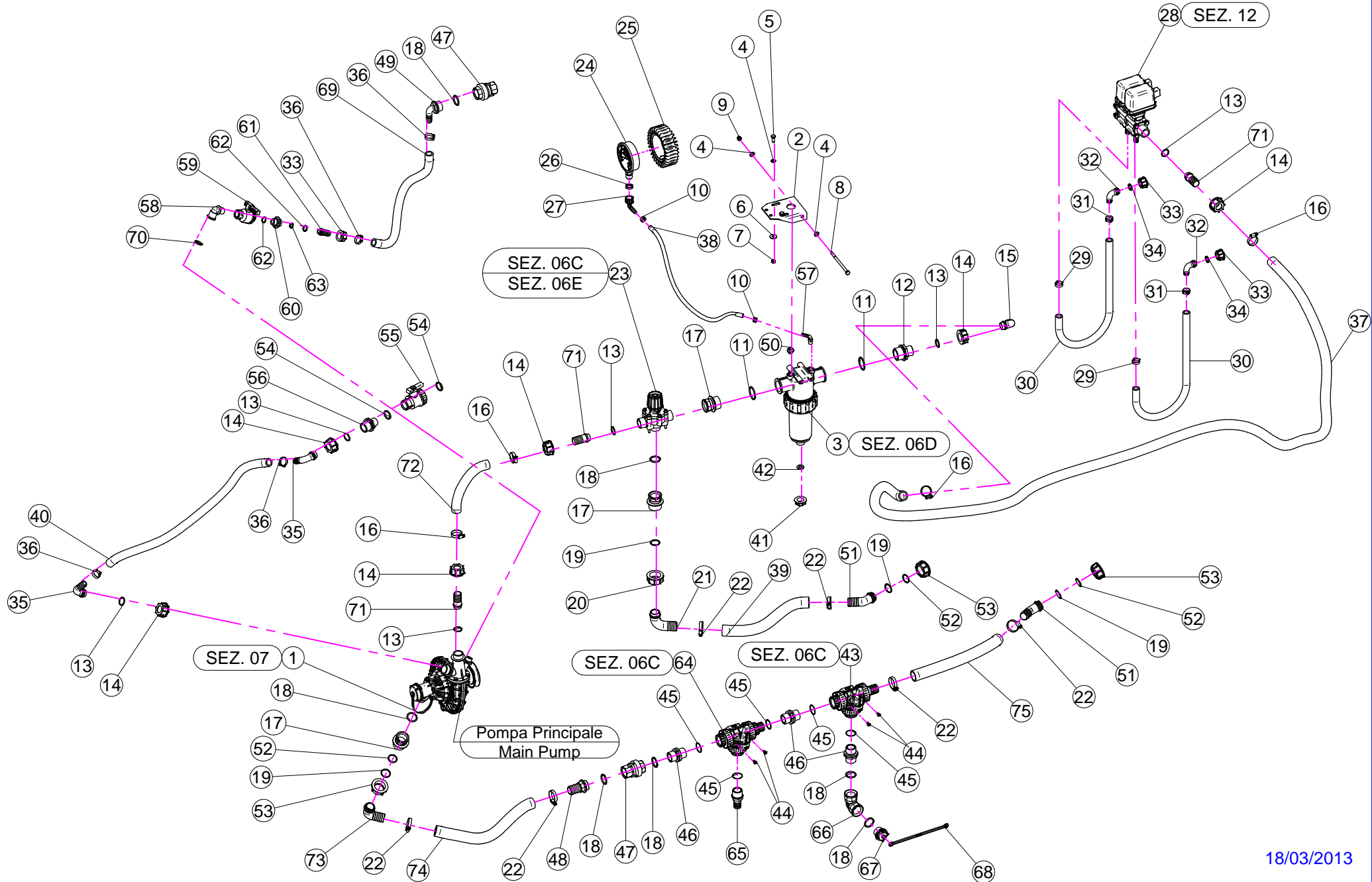

N°	Doc. Number	Titolo	Title	Q.tà	N°	Doc. Number	Titolo	Title	Q.tà
1	X02.157.071	POMPA COMPLETA	PUMP	1	39	X02.238.055	TUBO D. 30x41 L= 550	HOSE D. 30x41 L= 550	1
2	X20.519.100	STAFFA FISSAGGIO GRUPPO REGOLAZIONE	BRACKET	1	40	X02.212.100	TUBO D. 19x28 L= 1000	HOSE D. 19x28 L= 1000	1
3	X02.450.110	FILTRO IN LINEA F. 1" 1/4	LINE FILTER 1" 1/4 FEMALE	1	41	X02.182.000	TAPPO 3/4" FEMMINA	FEMALE 3/4" CAP	1
4	XRP.008.000	RONDELLA PIANA D.8	WASHER D.8	4	42	X02.030.010	GUARNIZIONE TAPPO DISTRIBUTORE	GASKET	1
5	XTE.008.025T	VITE TE 8X25	SCREW TE M8X25	2	43	X21.058.300	VALVOLA 3 VIE A SFERA CON 1 PG D.30	THREE WAYS VALVE	1
6	XRP.008.024	RONDELLA PIANA LARGA D.8X24	WASHER D.8X24	2	44	XTA.006.012P	VITI PER MAT. PLASTICI M6 x 12	SCREW M6 x 12	4
7	XD0.08.5588G	DADO M8 6S PG	M8 6S BIG LEAD NUT 5588	2	45	XOR.002.125	OR D.31,47 x 1,78	31,47 x 1,78 O-RING GASKET	5
8	XTE.008.130	VITE TE M8 x 130	SCREW M8 x 130	1	46	X00.055.034	NIPPLO 1" / 1" GAS	NIPPLE 1" / 1" GAS	3
9	XDA.008.0AG	DADO AUTOBLOCCANTE M8	SELF LOCKING NUT M8	1	47	X21.149.000	VALVOLA DI RITEGNO 1" F.-F.	VALVE 1" F.-F.	2
10	XFC.013.5.015	FASCETTA COBRA SLO30710	KOBRA CLAMP	2	48	X00.422.100	RACCORDO DIRITTO PG 30 FIL.1" GAS TORNITO	MALE CONNECTOR RH 30 1" GAS	1
11	XOR.000.144	OR D.39,69x3,53	O-RING D.39,69x3,53	2	49	X21.193.000	RACCORDO CURVO 90° 1" P.G.	HOSETAIL 90° 1" R.H.	1
12	X00.045.012	RIDUZIONE 1" 1/4 M - 1" M	1" 1/4 M - 1" M REDUCER NIPPLE	1	50	XTM.014.000	TAPPO MASCHIO 1/4"	MALE PLUG 1/4"	1
13	XOR.000.132	OR D.23,81 x 2,62	23,81 x 2,62 O-RING GASKET	6	51	X02.339.000	RACCORDO CURVO A 45° CON P.G. D.30	45° HOSETAIL	2
14	X00.055.24.2	GIRELLO 1" GAS	1" FLY NUT	6	52	XOR.003.106	OR D.26.65x2.62	O-RING D.26.65x2.62	3
15	X00.055.037	RACCORDO CURVO P.G. D.25	D.25 HOSETAIL	1	53	X00.493.000	GIRELLO 1" 1/4 GAS	1" 1/4 FLY NUT	3
16	XF0.023.035I	FASCETTA A VITE 23/35 W4 INOX	STAINLESS STEEL CLIP	4	54	XOR.000.134	OR D.25,8x3,53	O-RING D.25,8x3,53	2
17	X02.374.000	RIDUZIONE M/F 1" F / 1"1/4M	M. / F. 1" F / 1"1/4M REDUCTION	3	55	X02.395.000	RUBINETTO 3/4" GAS F.F. SFERA	VALVE 3/4" GAS F.F. BALL	1
18	XOR.004.118	OR D.29,75 x 3,53	29,75 x 3,53 O-RING GASKET	7	56	X02.293.000	RIDUZIONE 1" M - 3/4" M	1" M - 3/4" M REDUCER NIPPLE	1
19	XOR.003.112	OR D.28,24x2,62	O-RING D.28,24x2,62	4	57	X21.084.000	RACCORDO 90° WES 8 / R1/4	HOSETAIL 90° WES 8 / R1/4	1
20	X00.058.006	GIRELLO 1" 1/4 GAS	1" 1/4 FLY NUT	1	58	X21.180.000	CURVA 90° 1/2"M-1/2"F.	ELBOW 90° 1/2"M-1/2"F.	1
21	X00.058.004	RACCORDO CURVO P.G. D.30	D.30 HOSETAIL	1	59	X21.147.000	VALVOLA A SFERA 1/2" F/F	WAYS VALVE 1/2" F/F	1
22	XF0.025.040I	FASCETTA A VITE 25/40 W4 INOX	STAINLESS STEEL CLIP	6	60	X00.055.044	NIPPLO 1/2" GAS 3/4" GAS	NIPPLE 1/2" - 3/4" GAS	1
23	X02.447.000	VALVOLA A 3 VIE	3 WAY VALVE	1	61	X21.184.000	RACCORDO DIRITTO 3/4" P.G.20	STRAIGHT UNION 3/4" R.H.20	1
24	X02.445.000	MANOMETRO D.100 INOX 0-6 BAR	PRESSURE GAUGE Ø100 INOX 0-6 BAR	1	62	XOR.000.121	OR D. 15,88 x 2,62	15,88 x 2,62 O-RING GASKET	2
25	X02.470.000	CUFFIA PER MANOMETRO D.100	PRESSURE GAUGE GUARD	1	63	XOR.000.117	OR D. 13,1x18,34x2,62	13,1x18,34x2,62 O-RING GASKET	1
26	X24.072.000	GHIERA IN OTTONE 1/2"	BRASS FLY NUT 1/2"	1	64	X21.058.100	VALVOLA 3 VIE COMPLETA	THREE WAYS VALVE COMPLETE	1
27	X21.012.000	RACCORDO CURVO PG D. 12 G. 1/2"	D. 12 HOSETAIL	1	65	X02.403.000	RACCORDO DIRITTO PG D.25 - 1"	STRAIGHT HOSE R. H D.25 - 1"	1
28	X02.390.08C	ELETTROVALVOLE	ELECTROVALVES	1	66	X02.291.000	RACCORDO CURVO 1" FEMMINA	FEMALE HOSETAIL THREAD 1"	1
29	XFC.021.5.023	FASCETTA COBRA 21,5 - 23	KOBRA CLAMP 21,5 - 23	2	67	X21.182.000	TAPPO 1" M	PACKING 1" M	1
30	X02.211.110	TUBO D.16 L=1100	HOSE D.16 L=1100	2	68	X21.183.000	STRISCIA FERMATAPPI	CAP STOP	1
31	XFC.023.5.025	FASCETTA COBRA 23,5 - 25	KOBRA CLAMP 23,5 - 25	2	69	X02.212.080	TUBO D. 19 L= 800	HOSE D. 19 L= 800	1
32	X00.055.046	RACCORDO CURVO P.G. D.17	CURVED UNION WITH R.H. D.17	2	70	XOR.004.081	OR D.20,22 x 3,53	20,22 x 3,53 O-RING GASKET	1
33	X00.055.045	GIRELLO 3/4" GAS	3/4" FLY NUT	3	71	X00.055.021	RACCORDO DIRITTO PG D.25	STRAIGHT HOSE R.H D.25	3
34	X02.349.000	GUARNIZIONE PIANA D.17X23X3	17X23X3 FLAT GASKET	2	72	X20.809.026	TUBO D.25x32 CON RAMINO L=260	HOSE D.25x32 L=260	1
35	X00.055.038	RACCORDO CURVO A P.G. D.19	CURVED UNION WITH R.H. D.19	2	73	X00.483.000	RACCORDO CURVO PG 30 1-1/4"	D.30 1-1/4" HOSETAIL	1
36	XFC.026.5.028	FASCETTA COBRA 26,5 - 28	KOBRA CLAMP 26,5 - 28	4	74	X02.238.060	TUBO 30x38 L= 600	HOSE 30x38 L= 600	1
37	X20.770.287	TUBO D. 25x32 L= 2870	HOSE D. 25x32 L= 2870	1	75	X02.238.060	TUBO D. 30x38 L= 600	HOSE D. 30x38 L= 600	1
38	X02.217.040	TUBO D. 8x13 L= 400	HOSE D. 8x13 L= 400	1					

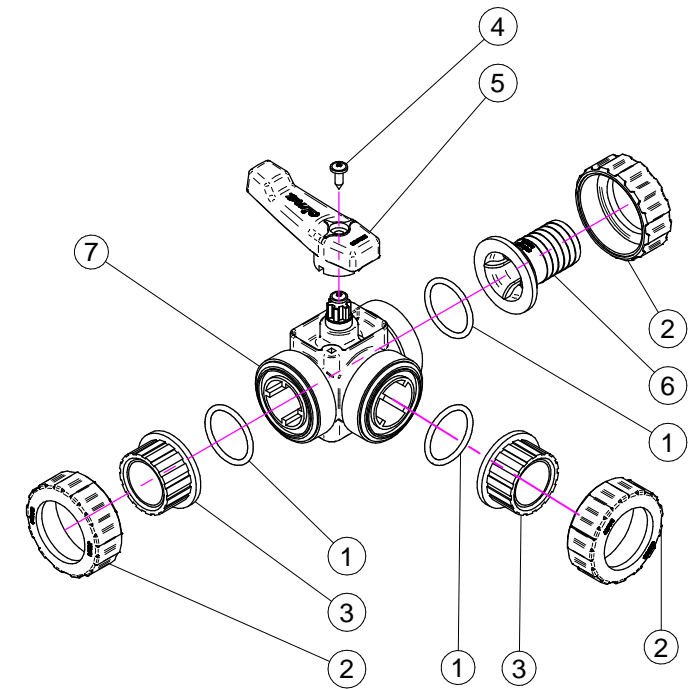
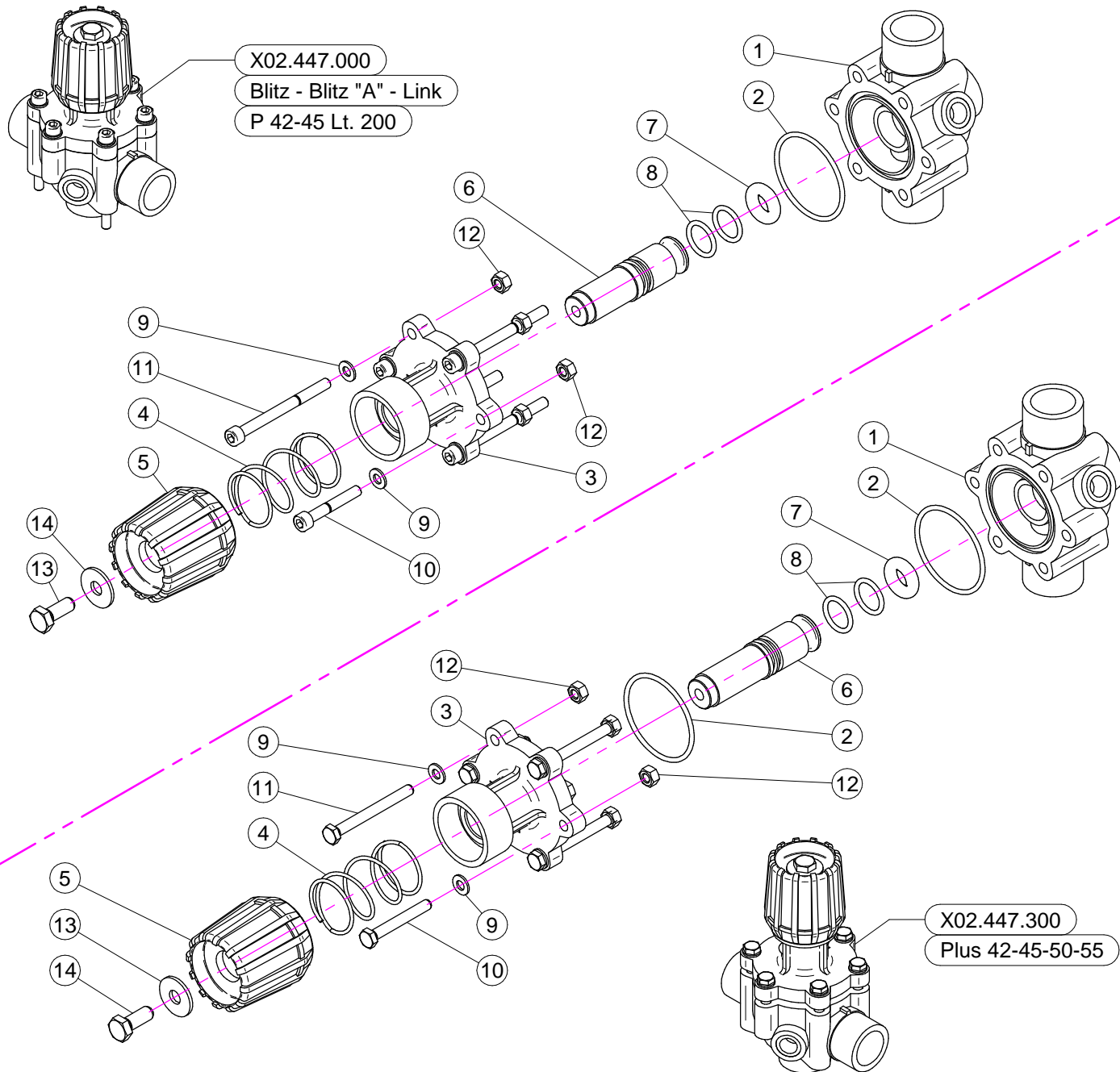

BLITZ - BLITZ "A" - LINK

N°	Doc. Number	Titolo	Title	Q.tà	Note
1	X02.447.001	CORPO VALVOLA DI REGOLAZIONE	BODY FOR REGULATION VALVE	1	
2	XOR.003.193	OR D.48,89x2,62	O-RING GASKET 48,89x2,62	1	
3	X02.447.009	FLANGIA SUPERIORE SERRANDA	UPPER FLANGE	1	
4	X02.447.011	MOLLA RECUPERO GIOCO	SPRING	1	
5	X02.447.010	MANOPOLA VALVOLA	REGULATION VALVE KNOB	1	
6	X02.447.014	PERNO PER REGOLATORE DI PRESSIONE	PIN	1	
7	X02.447.005	OR SPECIALE PER SERRANDA 2447	SPECIAL O-RING FOR GATE 2447	1	
8	XOR.003.068	OR D.17,12x2,62	O-RING GASKET 17,12x2,62	2	
9	XRP.006.000	RONDELLA PIANA D. 6	WASHER D.6	6	
10	XTCE.006 .040	VITE BRUGOLA TCE M6x40	BOLT TCE M6x40	2	
11	XTCE.006.070	VITE BRUGOLA TCE M6x70	BOLT TCE M6x70	4	
12	XD0.06.5588G	DADO M6	NUT M6	6	
13	XTE.008.025I	VITE TE 8X25 INOX	INOX 8X25 SCREW	1	
14	XRP.008.024I	RONDELLA PIANA LARGA D.8X24 INOX	INOX WASHER D.8X24	1	

PLUS 42-45-50-55

N°	Doc. Number	Titolo	Title	Q.tà	Note
1	X02.447.001	CORPO VALVOLA DI REGOLAZIONE	BODY FOR REGULATION VALVE	1	
2	XOR.003.193	OR D.48,89x2,62	O-RING GASKET 48,89x2,62	2	
3	X02.447.012	FLANGIA SUPERIORE SERRANDA	UPPER FLANGE	1	
4	X02.447.011	MOLLA RECUPERO GIOCO	SPRING	1	
5	X02.447.010	MANOPOLA VALVOLA	REGULATION VALVE KNOB	1	
6	X02.447.013	PERNO IN NYLON PER VALVOLA	VALVE PIN	1	
7	X02.447.005	OR SPECIALE PER SERRANDA 2447	SPECIAL O-RING FOR GATE 2447	1	
8	XOR.003.068	OR D.17,12x2,62	O-RING GASKET 17,12x2,62	2	
9	XRP.006.000I	RONDELLA PIANA D. 6 INOX	INOX WASHER D.6	6	
10	XTE.006.045I	VITE TE M6x45 INOX	INOX M6x45 SCREW	2	
11	XTE.006.060I	VITE TE M6x60 INOX	INOX M6x60 TE SCREW	4	
12	XD0.06.5588GI	DADO M6 6S PG INOX	INOX M6 6S BIG LEAD NUT 5588	6	
13	XRP.008.024I	RONDELLA PIANA LARGA D.8X24 INOX	INOX WASHER D.8X24	1	
14	XTE.008.025I	VITE TE 8X25 INOX	INOX 8X25 SCREW	1	

N°	Doc. Number	Titolo	Title	Q.tà
1	XOR.004.137	OR D.34.52x3.53	O-RING D.34.52x3.53	3
2	X21.058.007	GHIERA VALVOLA 3 VIE	VALVE UNION NUT	3
3	X21.058.006	MANICOTTO VALVOLA 3 VIE	VALVE END CONNECTOR	2
4	XTA.05.5.016	VITE AUTOFILETTANTE M5,5 x 16	SELFTHREADED SCREW M5,5 x 16	1
5	X21.058.003	MANIGLIA VALVOLA 3 VIE	VALVE HANDLE	1
6	X21.058.009	PORTAGOMMA D.30 RUBINETTO A 3 VIE	RUBBER HOLDER D.30	1
7	X21.058.110	CORPO VALVOLA 3 VIE	BODY OF THREE WAYS VALVE	1

CODICE-CODE
X02.450.100

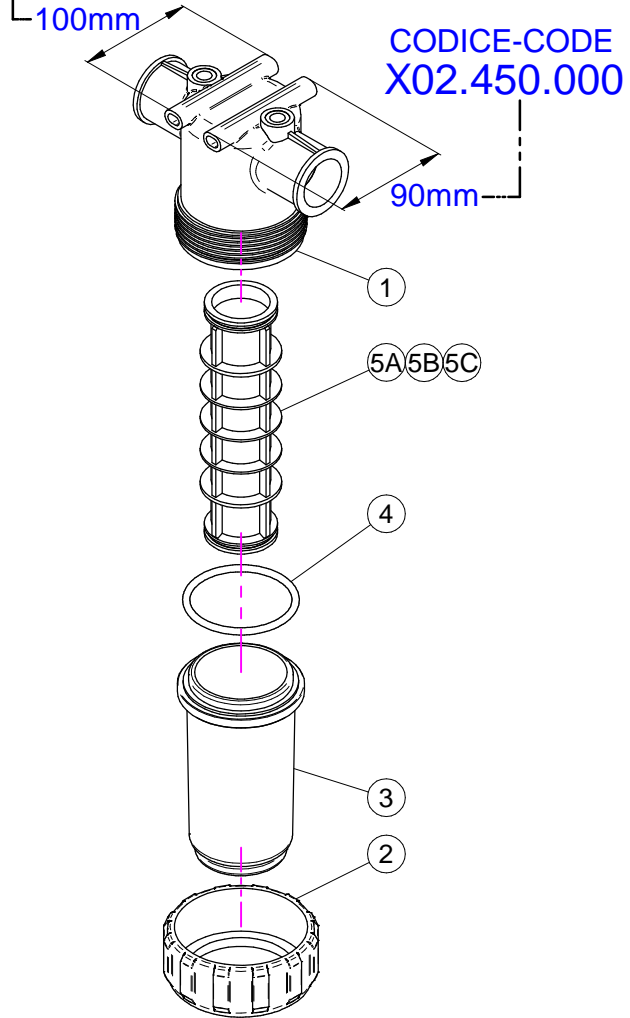

CODICE-CODE
X02.450.110

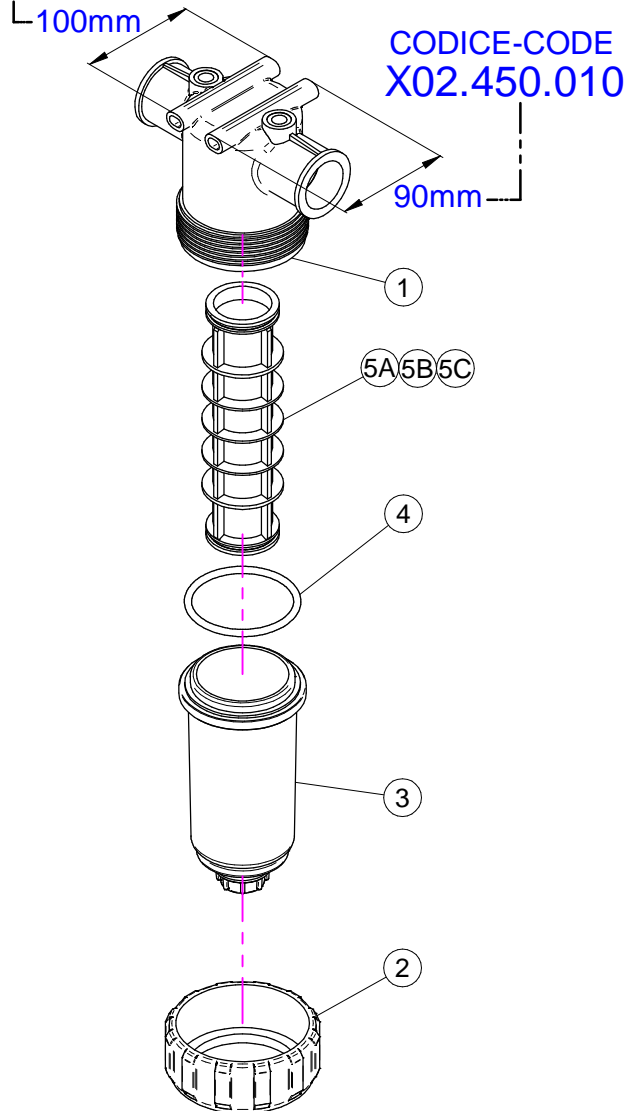

CODICE-CODE
X02.450.120

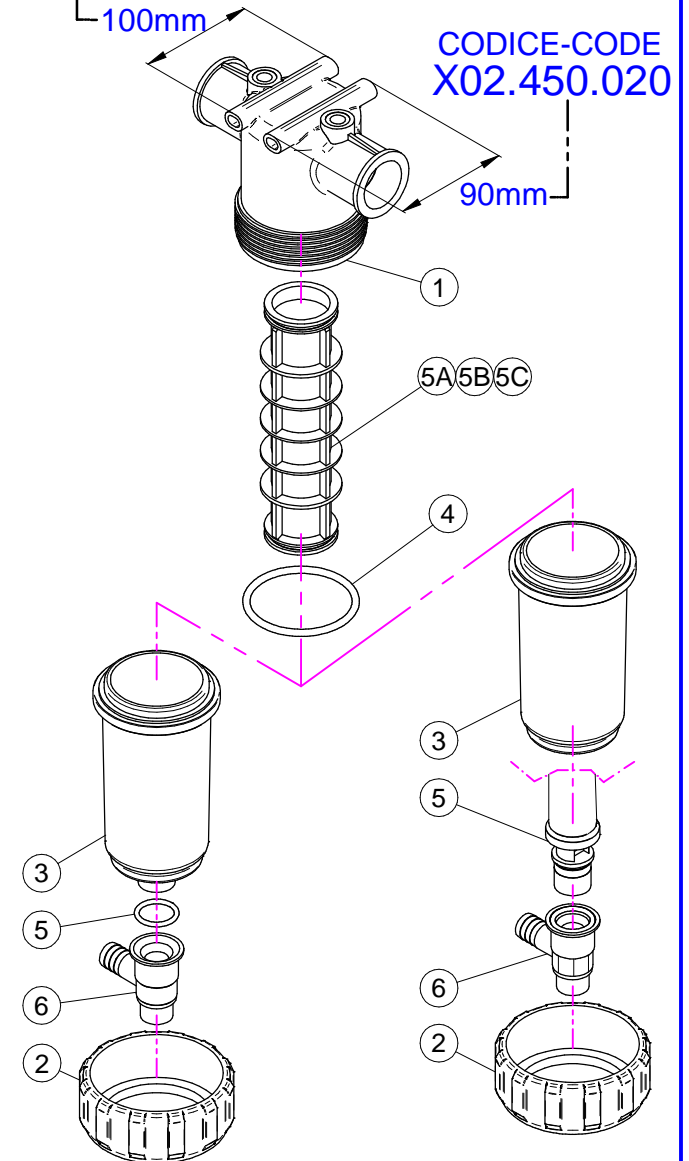

X02.450.100

N°	Doc. Number	Titolo	Title	Q.tà	Note
1	X02.450.101	CORPO FILTRO IN LINEA F. 1 1/4"	LINE FILTER BODY	1	
2	X02.450.003	GHIERA FILTRO IN LINEA	RING NUT FILTER IN LINE	1	
3	X02.450.002	COPERCHIO FILTRO	LID FILTER	1	
4	XOR.000.178	OR D.74,63x5,33	O-RING D.74,63x5,33	1	
5A	X02.450.004C	CARTUCCIA FILTRO CON OR 50 MESH (BLU)	CARTRIDGE WITH O-RING 50 MESH (BLUE)	1	
5B	X02.450.204C	CARTUCCIA FILTRO CON OR 80 MESH (GRIGIO)	CARTRIDGE WITH O-RING 80 MESH (GREY)	1	
5C	X02.450.104C	CARTUCCIA FILTRO CON OR 32 MESH (BIANCO)	CARTRIDGE WITH O-RING 32 MESH (WHITE)	1	

X02.450.000

N°	Doc. Number	Titolo	Title	Q.tà	Note
1	X02.450.001	CORPO FILTRO IN LINEA F. 1 1/4"	LINE FILTER BODY	1	
2	X02.450.003	GHIERA FILTRO IN LINEA	RING NUT FILTER IN LINE	1	
3	X02.450.002	COPERCHIO FILTRO	LID FILTER	1	
4	XOR.000.178	OR D.74,63x5,33	O-RING D.74,63x5,33	1	
5A	X02.450.004C	CARTUCCIA FILTRO CON OR 50 MESH (BLU)	CARTRIDGE WITH O-RING 50 MESH (BLUE)	1	
5B	X02.450.204C	CARTUCCIA FILTRO CON OR 80 MESH (GRIGIO)	CARTRIDGE WITH O-RING 80 MESH (GREY)	1	
5C	X02.450.104C	CARTUCCIA FILTRO CON OR 32 MESH (BIANCO)	CARTRIDGE WITH O-RING 32 MESH (WHITE)	1	

X02.450.110

N°	Doc. Number	Titolo	Title	Q.tà	Note
1	X02.450.101	CORPO FILTRO IN LINEA F. 1 1/4"	LINE FILTER BODY	1	
2	X02.450.003	GHIERA FILTRO IN LINEA	RING NUT FILTER IN LINE	1	
3	X02.450.011	COPERCHIO FILTRO CON SCARICO D.3/4"	LID FILTER WITH UNLOADING	1	
4	XOR.000.178	OR D.74,63x5,33	O-RING D.74,63x5,33	1	
5A	X02.450.004C	CARTUCCIA FILTRO CON OR 50 MESH (BLU)	CARTRIDGE WITH O-RING 50 MESH (BLUE)	1	
5B	X02.450.204C	CARTUCCIA FILTRO CON OR 80 MESH (GRIGIO)	CARTRIDGE WITH O-RING 80 MESH (GREY)	1	
5C	X02.450.104C	CARTUCCIA FILTRO CON OR 32 MESH (BIANCO)	CARTRIDGE WITH O-RING 32 MESH (WHITE)	1	

X02.450.010

N°	Doc. Number	Titolo	Title	Q.tà	Note
1	X02.450.001	CORPO FILTRO IN LINEA F. 1 1/4"	LINE FILTER BODY	1	
2	X02.450.003	GHIERA FILTRO IN LINEA	RING NUT FILTER IN LINE	1	
3	X02.450.011	COPERCHIO FILTRO CON SCARICO D.3/4"	LID FILTER WITH UNLOADING	1	
4	XOR.000.178	OR D.74,63x5,33	O-RING D.74,63x5,33	1	
5A	X02.450.004C	CARTUCCIA FILTRO CON OR 50 MESH (BLU)	CARTRIDGE WITH O-RING 50 MESH (BLUE)	1	
5B	X02.450.204C	CARTUCCIA FILTRO CON OR 80 MESH (GRIGIO)	CARTRIDGE WITH O-RING 80 MESH (GREY)	1	
5C	X02.450.104C	CARTUCCIA FILTRO CON OR 32 MESH (BIANCO)	CARTRIDGE WITH O-RING 32 MESH (WHITE)	1	

X02.450.120

N°	Doc. Number	Titolo	Title	Q.tà	Note
1	X02.450.101	CORPO FILTRO IN LINEA F. 1 1/4"	LINE FILTER BODY	1	
2	X02.450.003	GHIERA FILTRO IN LINEA	RING NUT FILTER IN LINE	1	
3	X02.450.011	COPERCHIO FILTRO CON SCARICO D.3/4"	LID FILTER WITH UNLOADING	1	
4	XOR.000.178	OR D.74,63x5,33	O-RING D.74,63x5,33	1	
5	XOR.000.134	OR D.25,8x3,53	O-RING D.25,8x3,53	1	
6	X02.450.120.D	RUBINETTO AUTOPULENTE PER FILTRO	FAUCET FOR FILTER	1	
7A	X02.450.004C	CARTUCCIA FILTRO CON OR 50 MESH (BLU)	CARTRIDGE WITH O-RING 50 MESH (BLUE)	1	
7B	X02.450.204C	CARTUCCIA FILTRO CON OR 80 MESH (GRIGIO)	CARTRIDGE WITH O-RING 80 MESH (GREY)	1	
7C	X02.450.104C	CARTUCCIA FILTRO CON OR 32 MESH (BIANCO)	CARTRIDGE WITH O-RING 32 MESH (WHITE)	1	

X02.450.020

N°	Doc. Number	Titolo	Title	Q.tà	Note
1	X02.450.001	CORPO FILTRO IN LINEA F. 1 1/4"	LINE FILTER BODY	1	
2	X02.450.003	GHIERA FILTRO IN LINEA	RING NUT FILTER IN LINE	1	
3	X02.450.020.A	COPERCHIO FILTRO IN LINEA 1" 1/4	LINE FILTER LID 1" 1/4	1	
4	XOR.000.178	OR D.74,63x5,33	O-RING D.74,63x5,33	1	
5	X02.450.020.B	CORPO CENTRALE CON TAPPO 1" 1/4	CENTRAL BODY WITH CAP 1" 1/4	1	
6	X02.450.020.D	RUBINETTO AUTOPULENTE PER FILTRO	FAUCET FOR FILTER	1	
7A	X02.450.004C	CARTUCCIA FILTRO CON OR 50 MESH (BLU)	CARTRIDGE WITH O-RING 50 MESH (BLUE)	1	
7B	X02.450.204C	CARTUCCIA FILTRO CON OR 80 MESH (GRIGIO)	CARTRIDGE WITH O-RING 80 MESH (GREY)	1	
7C	X02.450.104C	CARTUCCIA FILTRO CON OR 32 MESH (BIANCO)	CARTRIDGE WITH O-RING 32 MESH (WHITE)	1	

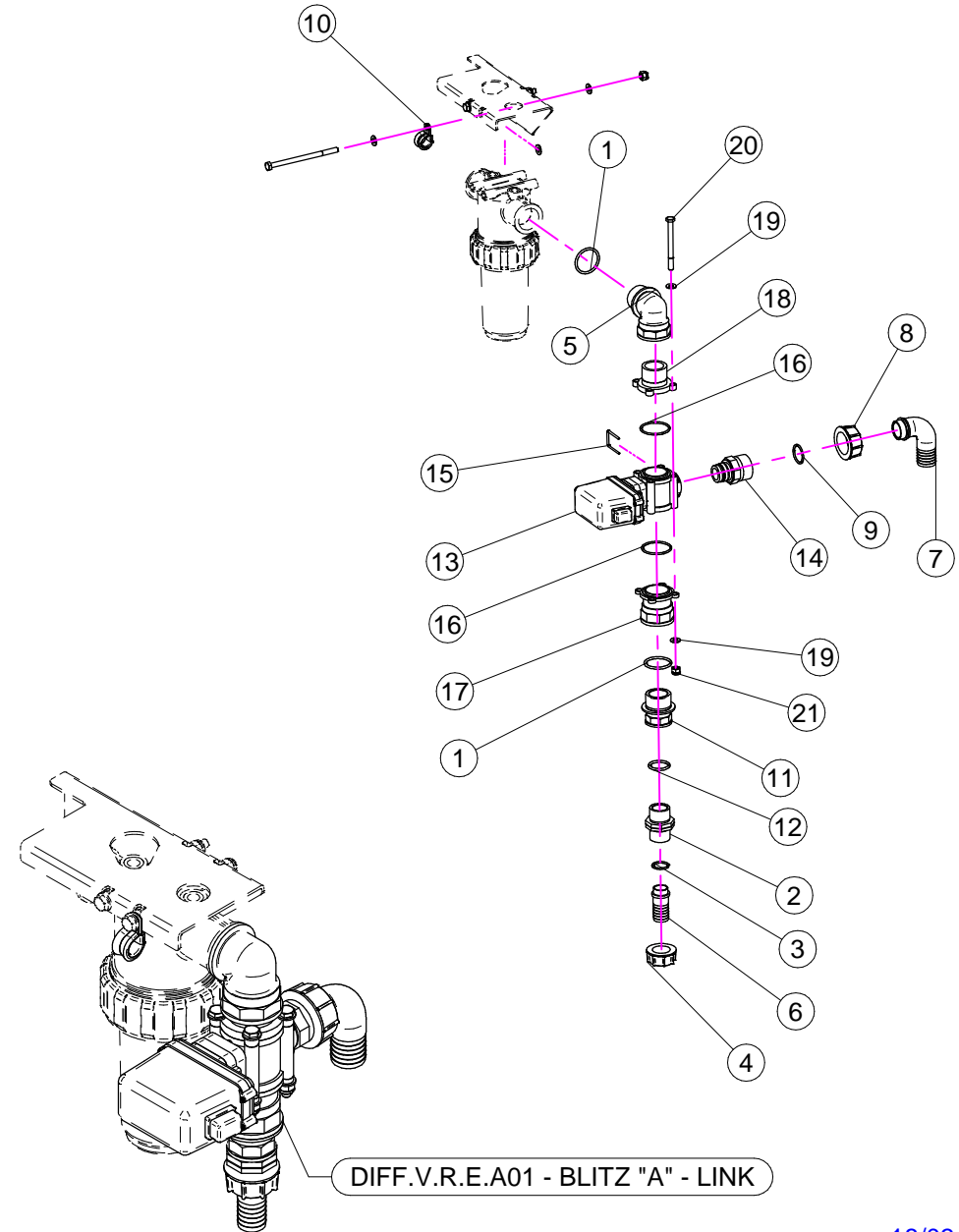
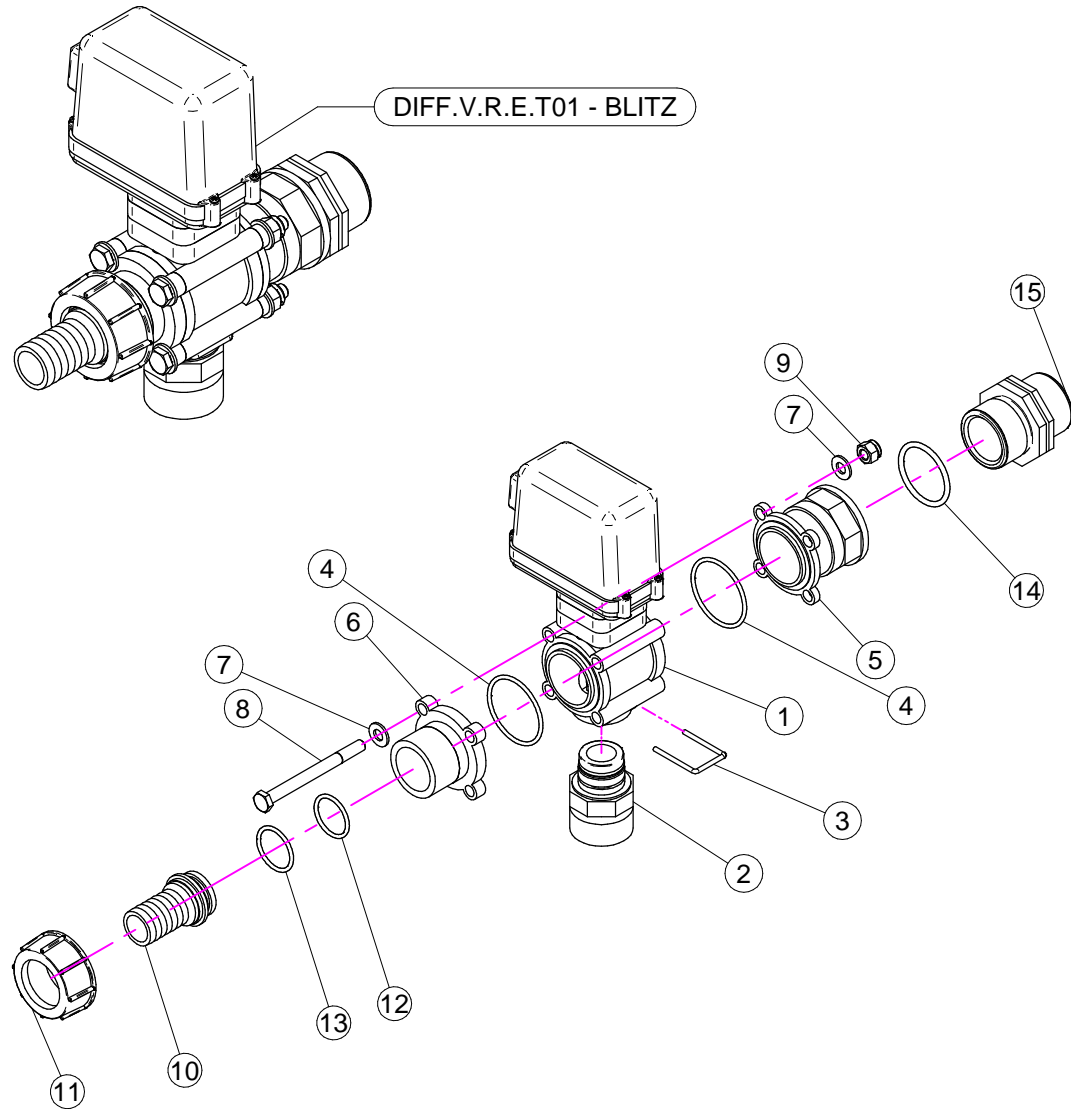

DIFF.V.R.E.T01
BLITZ

N°	Doc. Number	Titolo	Title	Q.tà	Note
1	X21.130.000	VALVOLA MOTORIZZATA PROPORZIONALE	ELECTRIC PROPORTIONAL VALVE	1	
2	X21.131.000	RIDUZIONE ATT.RAP. G 1" 1/4	REDUCTION J. F. G 1" 1/4	1	
3	X21.130.005	FORCHETTA ATTACCO RAPIDO	FORK FASTNER JOINT	1	
4	XOR.003.181	OR D. 45,69x50,93x2,62	45,69x50,93x2,62 O-RING	2	
5	X21.133.000	RACCORDO FLANGIATO 1" - 1 1/4"	CONNECTOR	1	
6	X21.132.000	FLANGIA VALVOLE	VALVE FLANGE	1	
7	XRP.008.000	RONDELLA PIANA D.8	WASHER D.8	8	
8	XTE.008.090	VITE TE M8 x 90	SCREW TE M8 x 90	4	
9	XDA.008.0AG	DADO AUTOBLOCCANTE M8	SELF LOCKING NUT M8	4	
10	X02.363.000	RACCORDO DIRITTO PG D.25 - 1 1/4	STRAIGHT HOSE R.H D.25 - 1 1/4	1	
11	X00.058.006	GIRELLO 1" 1/4 GAS	1" 1/4 FLY NUT	1	
12	XOR.003.106	OR D.26.65x2.62	O-RING D.26.65x2.62	1	
13	XOR.003.112	OR D.28,24x2,62	O-RING D.28,24x2,62	1	
14	XOR.000.144	OR D.39,69x3,53	O-RING D.39,69x3,53	1	
15	X00.345.010	NIPPLO 1" 1/4 + 1" 1/4 GAS	NIPPLE 1" 1/4 + 1" 1/4 GAS	1	

DIFF.V.R.E.A01
BLITZ "A" - LINK

N°	Doc. Number	Titolo	Title	Q.tà	Note
1	XOR.000.144	OR D.39,69x3,53	O-RING D.39,69x3,53	2	
2	X00.055.034	NIPPLO 1" / 1" GAS	NIPPLE 1" / 1" GAS	1	
3	XOR.000.132	OR D.23,81 x 2,62	23,81 x 2,62 O-RING GASKET	1	
4	X00.055.24.2	GIRELLO 1" GAS	1" FLY NUT	1	
5	X24.070.000	RACCORDO CURVO M-F 1"1/4	HOSETAIL 1"1/4	1	
6	X00.055.021	RACCORDO DIRITTO PG D.25	STRAIGHT HOSE R.H D.25	1	
7	X00.058.004	RACCORDO CURVO P.G. D.30	D.30 HOSETAIL	1	
8	X00.058.006	GIRELLO 1" 1/4 GAS	1" 1/4 FLY NUT	1	
9	XOR.003.112	OR D.28,24x2,62	O-RING D.28,24x2,62	1	
10	XFG.018.000	FASCETTA GOMMATA PER TUBI D.18	STICKER	1	
11	X02.374.000	RIDUZIONE M/F 1"F / 1"1/4M	M. / F. 1"F / 1"1/4M REDUCTION	1	
12	XOR.004.118	OR D.29,75 x 3,53	29,75 x 3,53 O-RING GASKET	1	
13	X21.130.000	VALVOLA MOTORIZZATA PROPORZIONALE	ELECTRIC PROPORTIONAL VALVE	1	
14	X21.131.000	RIDUZIONE ATT.RAP. G 1" 1/4	REDUCTION J. F. G 1" 1/4	1	
15	X21.130.005	FORCHETTA ATTACCO RAPIDO	FORK FASTNER JOINT	1	
16	XOR.003.181	OR D. 45,69x50,93x2,62	45,69x50,93x2,62 O-RING	2	
17	X21.133.000	RACCORDO FLANGIATO 1" - 1 1/4"	CONNECTOR	1	
18	X21.132.000	FLANGIA VALVOLE	VALVE FLANGE	1	
19	XRP.008.000	RONDELLA PIANA D.8	WASHER D.8	8	
20	XTE.008.090	VITE TE M8 x 90	SCREW TE M8 x 90	4	
21	XDA.008.0AG	DADO AUTOBLOCCANTE M8	SELF LOCKING NUT M8	4	

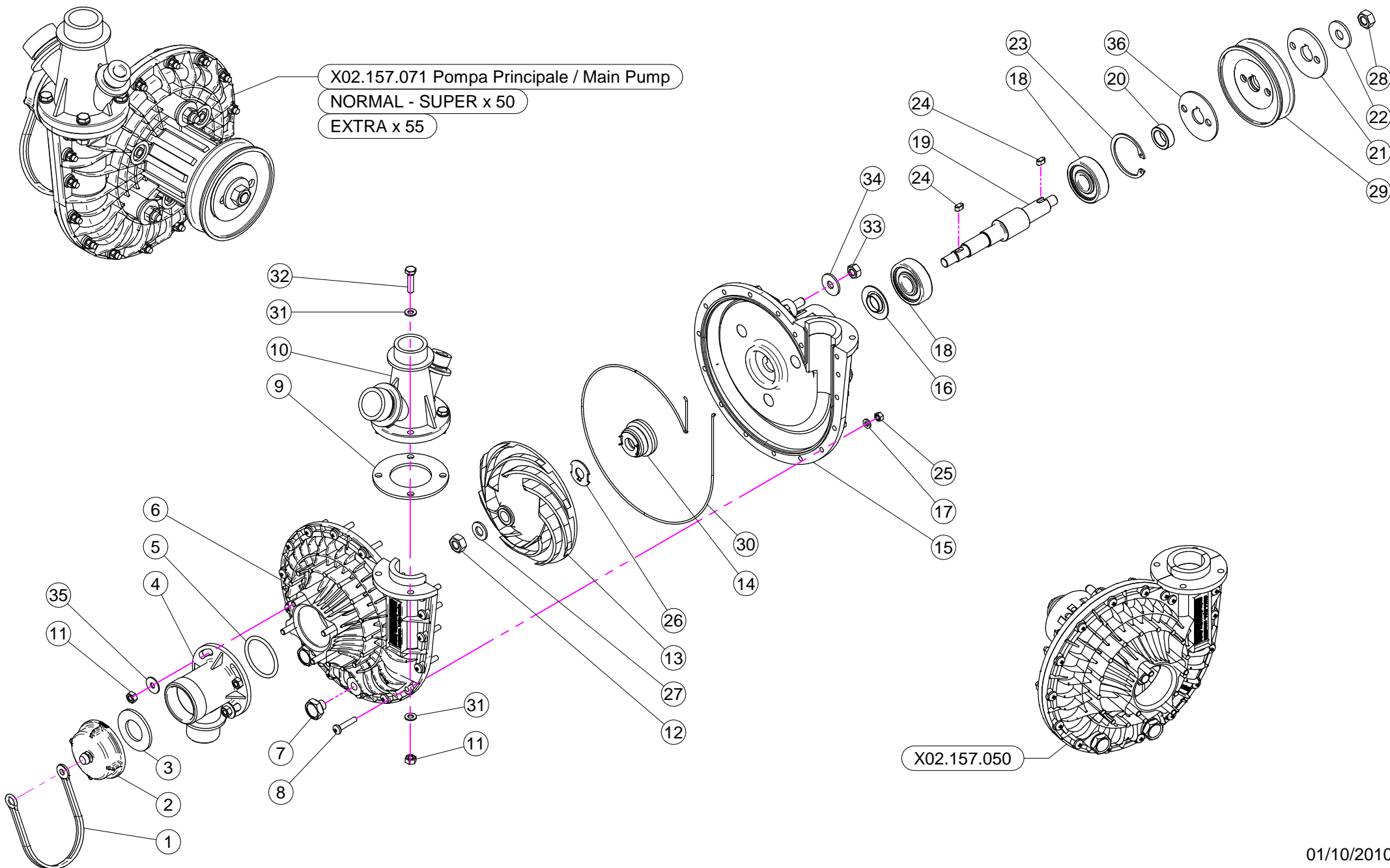

N°	Doc. Number	Titolo	Title	Qtà	Note
1	X21.183.000	STRISCIA FERMATAPPI	CAP STOP	1	
2	X02.120.000	TAPPO A FILETTO RAPIDO M47 x 5	RAPID THREAD CAP	1	
3	X02.130.000	GUARNIZIONE IN GOMMA DIAM. 24X46X3	24X46X3 RUBBER GASKET	1	
4	X02.116.000	RACCORDO DI ASPIRAZIONE	SUCTION FITTING	1	
5	XOR.000.144	OR D.39,69x3,53	O-RING D.39,69x3,53	1	
6	X02.152.010	COPERCHIO POMPA CD 32	HOUSING	1	
7	XTM.010.015	TAPPO M10X1,5	M10X1,5 CAP	2	
8	XTC.05.25.85	VITE TESTA A CROCE 48 M5X25	CROSS SLOTTED SCREW M5X25	17	
9	X02.179.000	GUARNIZIONE IN GOMMA	RUBBER GASKET	1	
10	X02.113.000	RACCORDO DI MANDATA	DELIVERY FITTING	1	
11	XDOT.06.5587	DADO OTTONE M6	M6 BRASS NUT 5587	8	
12	XDOT.10.5587	DADO OTTONE M10	M10 BRASS NUT	1	
13	X02.153.000	GIRANTE POMPA CD 32	CD 32 PUMP IMPELLER	1	
14	X00.085.024CS	TENUTA MECCANICA	MECHANICAL SEAL	1	
15	X02.151.010	CORPO POMPA CD 32	PUMP CASING	1	
16	X20.406.000	COPERCHIETTO SPECIALE POMPA CD 32	SPECIAL COVER FOR PUMP	1	
17	XRP.005.000	RONDELLA PIANA D.5	WASHER D.5	17	
18	XK6.303.2RS	CUSCINETTO A SFERE	ROLLER BEARING	2	
19	X02.155.010	ALBERO POMPA CD 32 INOX LUNGO	CD32 PUMP SHAFT	1	
20	X02.722.000	DISTANZIALE POMPA	BUSH	1	
21	X02.723.001	RONDELLA SPECIALE mm3	SPECIAL WASHER mm3	1	
22	XRP.010.030	RONDELLA PIANA D.10 x 30 mm	WASHER D.10 x 30 mm	1	
23	XI0.047.000	ANELLO ELASTICO INTERNO D.47	INTERNAL D.47 CIRCLIP	1	
24	XL.05.05.10	LINGUETTA 5X5X10	5X5X10 TANG	2	
25	XDOT.05.5587	DADO OTTONE M5 (5587)	M5 BRASS NUT (5587)	17	
26	X02.114.000	RONDELLA SPECIALE INOX	INOX SPECIAL WASHER	1	
27	XRP.010.001	RONDELLA PIANA D.10 INOX	WASHER D.10 INOX	1	
28	XD0.10.5588G	DADO M 10 6S PG	M10 6S BIG LEAD NUT 5588	1	
29	X02.723.002	PULEGGIA COMANDO POMPA D.82,5 X 1 3V	PULLEY FOR PUMP D.82,5 X 1 3V	1	
30	XOR.C02.070	CORDA OR D.2 L=700	OR CORD D.2 L=700	1	
31	XRP.006.000	RONDELLA PIANA D. 6	WASHER D.6	8	
32	XTE.006.025T	VITE TE M6X25	SCREW TE M6X25	4	
33	XD0.08.5588G	DADO M8 6S PG	M8 6S BIG LEAD NUT 5588	3	
34	XRP.008.024	RONDELLA PIANA LARGA D.8X24	WASHER D.8X24	3	
35	XRP.006.018	RONDELLA PIANA D. 6x18	WASHER D.6x18	3	
36	X02.723.005	RONDELLA SPECIALE mm2	SPECIAL WASHER mm2	1	

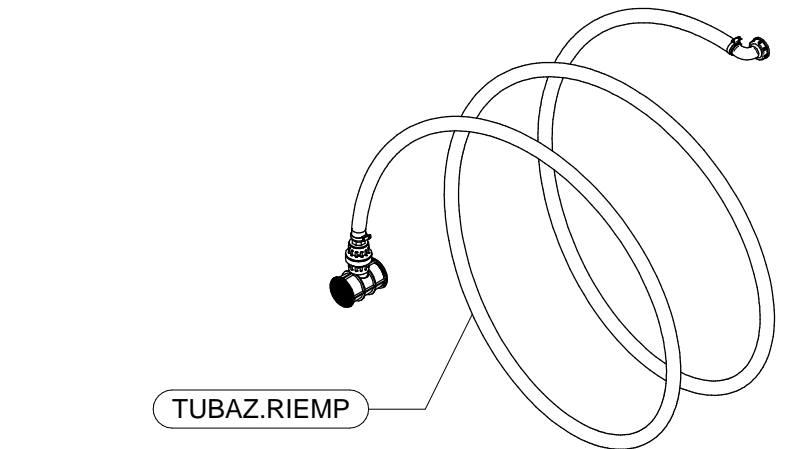
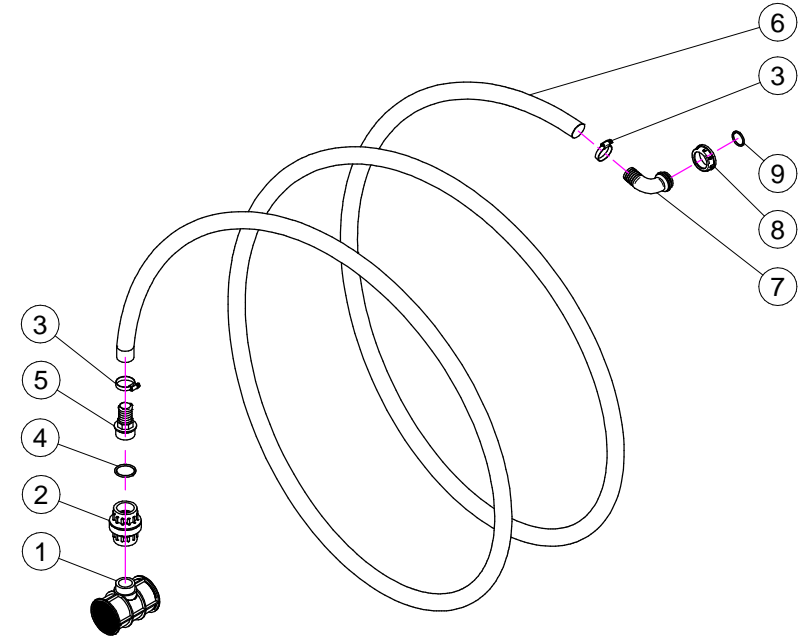
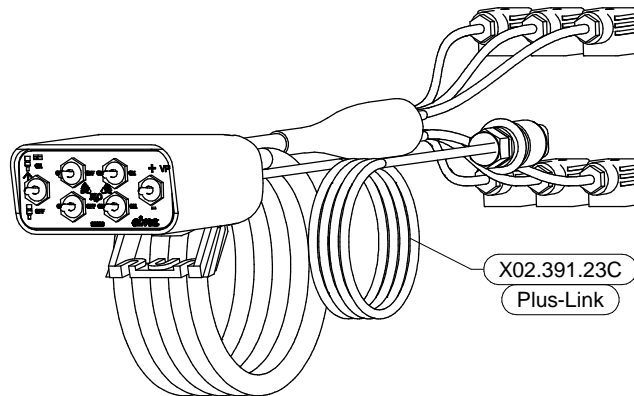
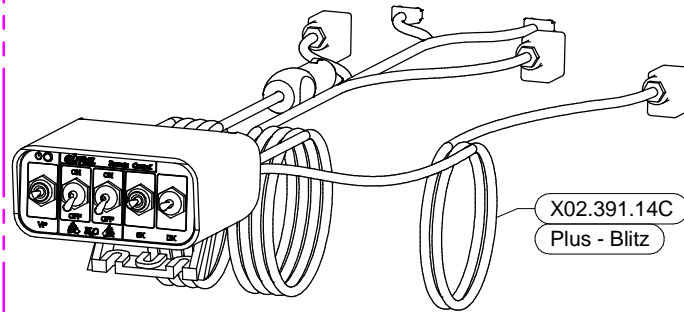
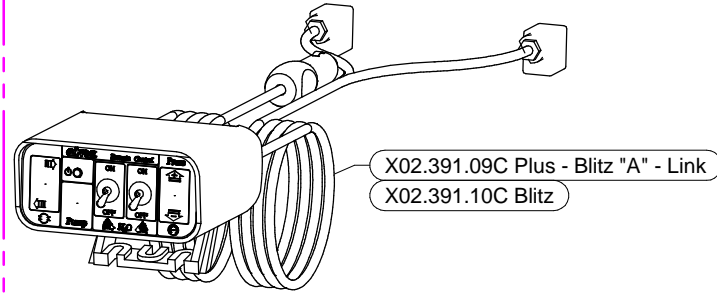
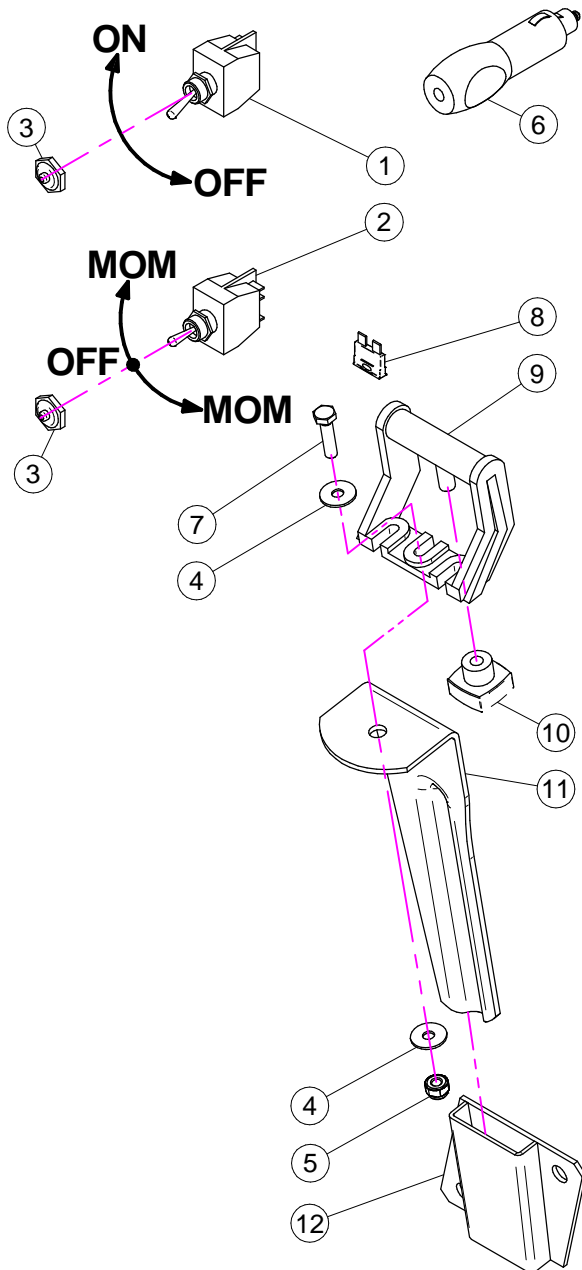

X02.391.09C / 10C / 14C / 23C

N°	Doc. Number	Titolo	Title	Q.tà	Note
1	X21.030.005	DEVIATORE 2V 2P ON-OFF 10A	SWITCH 2V 2P ON-OFF 10A	1	
2	X21.030.006	DEVIATORE MOM - 0 - MOM 10A	SWITCH MOM - 0 - MOM 10A	1	
3	X21.030.007	CAPPUCCIO INTERRUTTORE D.12	SWITCH CAP D.12	2	
4	XRP.006.018	RONDELLA PIANA D. 6x18	WASHER D.6x18	2	
5	XDA.006.0AG	DADO AUTOBLOCCANTE M6 ALTO PG	SELF-LOCKING NUT - HIGH M6	1	
6	X21.030.008	CONNETTORE DI ALIMENTAZIONE 12V	12V POWER JACK	1	
7	XTE.006.025T	VITE TE M6X25	SCREW TE M6X25	1	
8	X21.030.004	FUSIBILE - 10 Ah	10 Ah FUSE	1	
9	X21.030.002	STAFFA DI FISSAGGIO MOBILE	MOVING FIXING BRACKET	1	
10	X21.030.003	POMELLO DI BLOCCAGGIO	FIXING KNOB	1	
11	X20.111.000	STAFFA PORTA BAIONETTA	BRACKET	1	
12	X20.107.000	SUPPORTO A BAIONETTA FEMMINA	FEMALE BAYONET SUPPORT	1	

TUBAZ.RIEMP

N°	Doc. Number	Titolo	Title	Q.tà	Note
1	X00.611.000	FILTRO A T PER TUBAZIONE RIEMPIMENTO	T FILTER	1	
2	X00.300.000	VALVOLA DI FONDO F-F 1" 1/4	FOOT VALVE F-F 1" 1/4	1	
3	XF0.025.040I	FASCETTA A VITE 25/40 W4 INOX	STAINLESS STEEL CLIP	2	
4	XOR.000.144	OR D.39,69x3,53	O-RING D.39,69x3,53	1	
5	X00.423.000	RACCORDO DIRITTO PG 30 FIL.1" 1/4 GAS	MALE CONNECTOR RH 30 1" 1/4 GAS	1	
6	X02.238.450	TUBO SPIRALATO D.30 L=4500	SPIRAL HOSE D.30 L=4500	1	
7	X00.481.000	RACCORDO CURVO P.G. D.30	D.30 HOSETAIL	1	
8	X02.165.000	GIRELLO A FILETTO RAPIDO	RAPID THREAD FLY NUT	1	
9	XOR.000.508	OR D.30 x 3	30 x 3 O-RING GASKET	1	

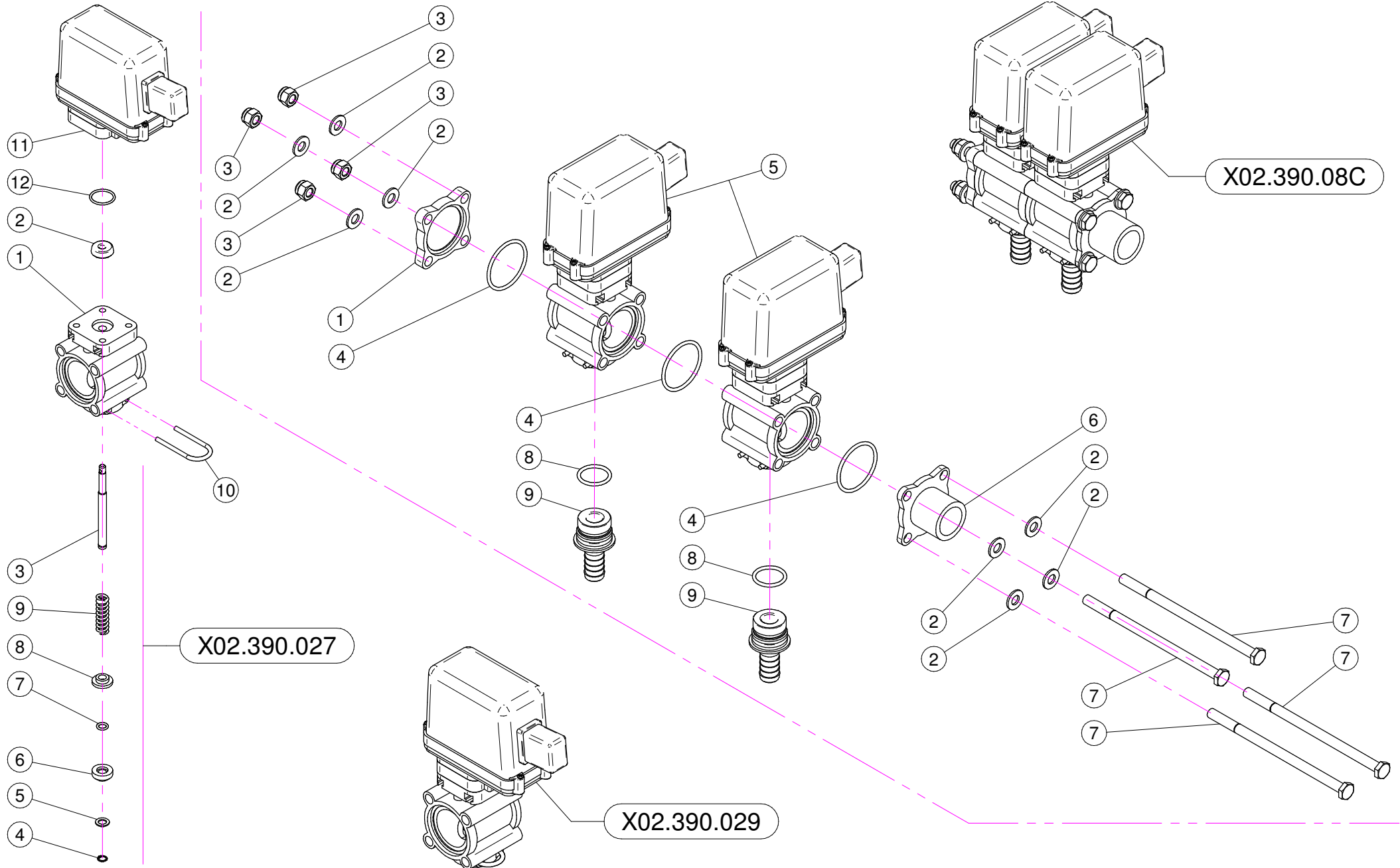

X02.390.029

N°	Doc. Number	Titolo	Title	Q.tà	Note
1	X02.390.007	CORPO VALVOLA	VALVE BODY	1	
2	X02.390.008	GUARNIZIONE D.6x17x6 VITON	GASKET	1	
3	X02.390.020	PERNO VALVOLA MANUALE INOX	PIN	1	
4	X02.390.013	ANELLO ARRESTO	STOP RING	1	
5	X02.390.014	RONDELLA PIANA 7,2 x 12 INOX	WASHER 7,2 x 12 INOX	1	
6	X02.390.015	PIATTELLO INFERIORE VALVOLA	LOWER PIATTELLO VALVE	1	
7	X02.390.016	OR 6,7 x 1,78	O RING	1	
8	X02.390.009	PIATTELLO SUPERIORE VALVOLE	SUPERIOR PIATTELLO VALVES	1	
9	X02.390.011	MOLLA DI RITEGNO	SPRING	1	
10	X21.130.005	FORCHETTA PER RUB. MAN. SEMP. PR	FORK	1	
11	X02.390.028	ELETTRIVALVOLA COMPLETA ARAG BLU	SOLENOID VALVE	1	
12	XOR.002.075	OR D.18.77 X 1.78	D.18.77 X 1.78 O-RING	1	

X02.390.08C

N°	Doc. Number	Titolo	Title	Q.tà	Note
1	X02.390.017	FLANGIA VALVOLE	VALVE FLANGE	1	
2	XRP.008.000	RONDELLA PIANA D.8	WASHER D.8	8	
3	XDA.008.0AG	DADO AUTOBLOCCANTE M8	SELF LOCKING NUT M8	4	
4	XOR.003.156	OR D.39,34x2,62	O-RING GASKET 39,34x2,62	3	
5	X02.390.029	ELETTRIVALVOLA COMPLETA ARAG BLU	SOLENOID VALVE	2	
6	X02.390.018	RACCORDO FLANGIATO 1" GAS	CONNECTOR	1	
7	XTE.008.150	VITE TE M8x150	SCREW TE M8 x 150	4	
8	XOR.000.130	OR D.22,22 x 2,62	22,22 x 2,62 O-RING GASKET	2	
9	X02.406.000	PORTAGOMMA D.16 ATT.RAP. PER ELETT.	HOSETAIL D.16	2	

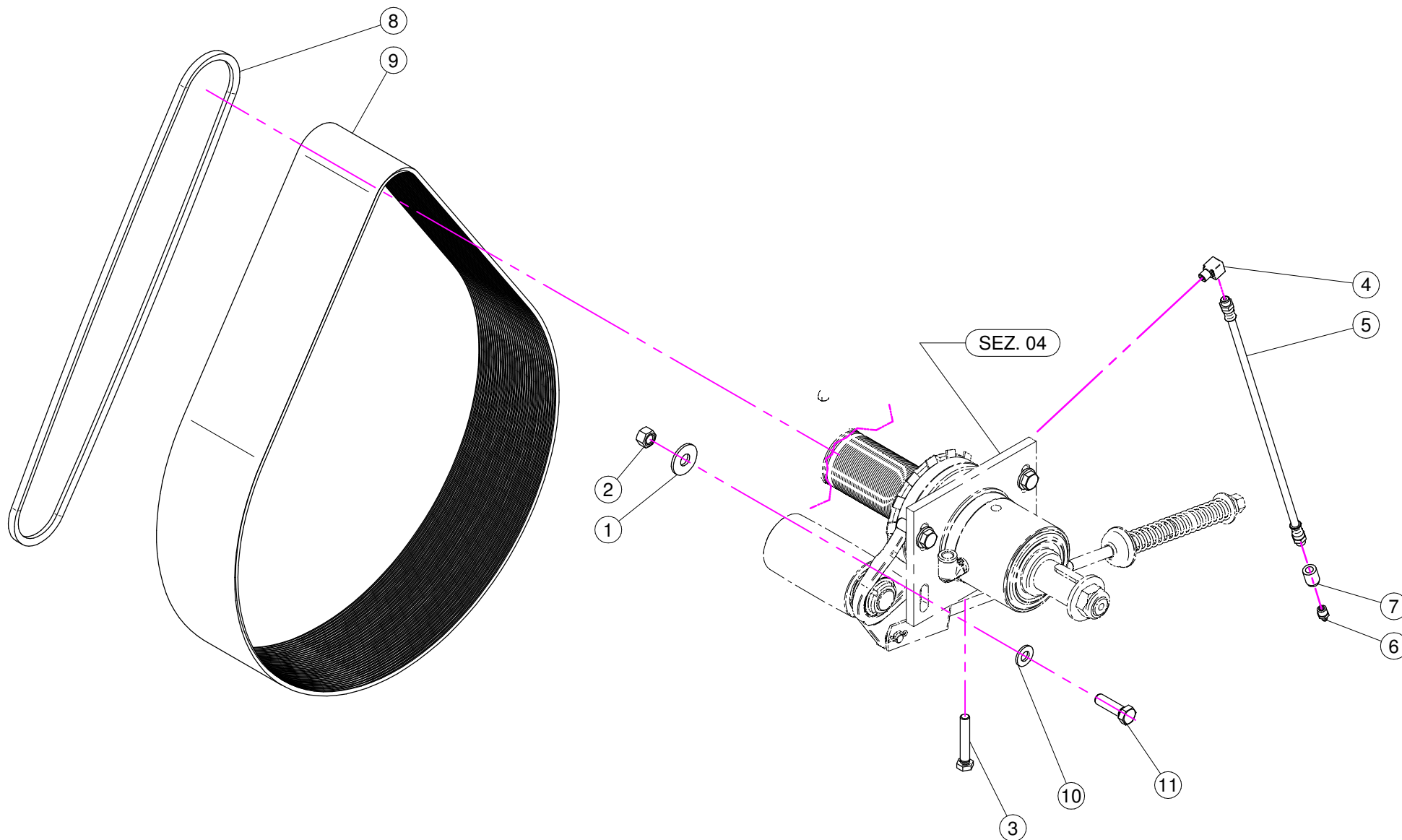

N°	Doc. Number	Titolo	Title	Q.tà	Note
1	XRP.012.036	RONDELLA PIANA D12 X 36	WASHER D12 X 36	4	
2	XD0.12.5587G	DADO M12 PG UNI 5587	M12 NUT	4	
3	XTE.010.060T	VITE TE M10 x 60	SCREW TE M10 x 60	1	
4	X02.736.000	RACCORDO INGRASSAGGIO 90 G. M10 X1	90 G. M10 X1 FITTING	1	
5	X02.738.040	PROLUNGA FLESSIBILE M10 x 1 L= 400	GREASER EXTENSION M10 x 1 L= 400	1	
6	XID.010.001	INGRASSATORE DIRITTO M10X1	GREASE NIPPLE	1	
7	X02.737.000	BOCCOLA PER INGRASSATORE	ACCESSORI	1	
8	XC0.500.03V	CINGHIA TRAPEZOIDALE	V - BELT	2	
9	XC0.690.J50	CINGHIA POLY-V	POLY-V BELT	1	
10	XRP.012.000	RONDELLA PIANA D. 12	WASHER D. 12	1-(2)	
11	XTE.012.040T	VITE TE M12X40 UNI 5739	BOLT TE M12X40	4	

DI SERIE / STANDARD

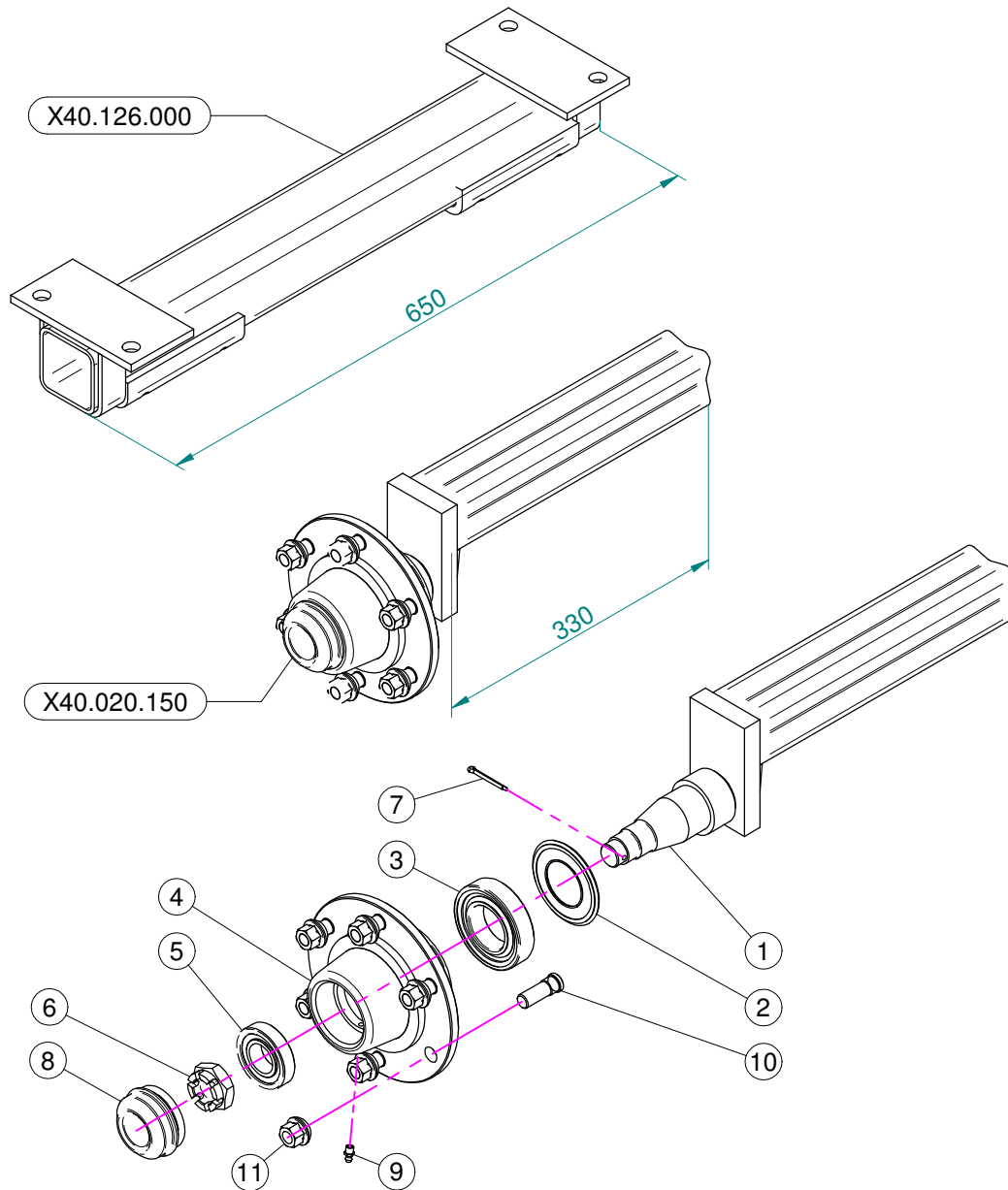

A RICHIESTA / OPTIONAL

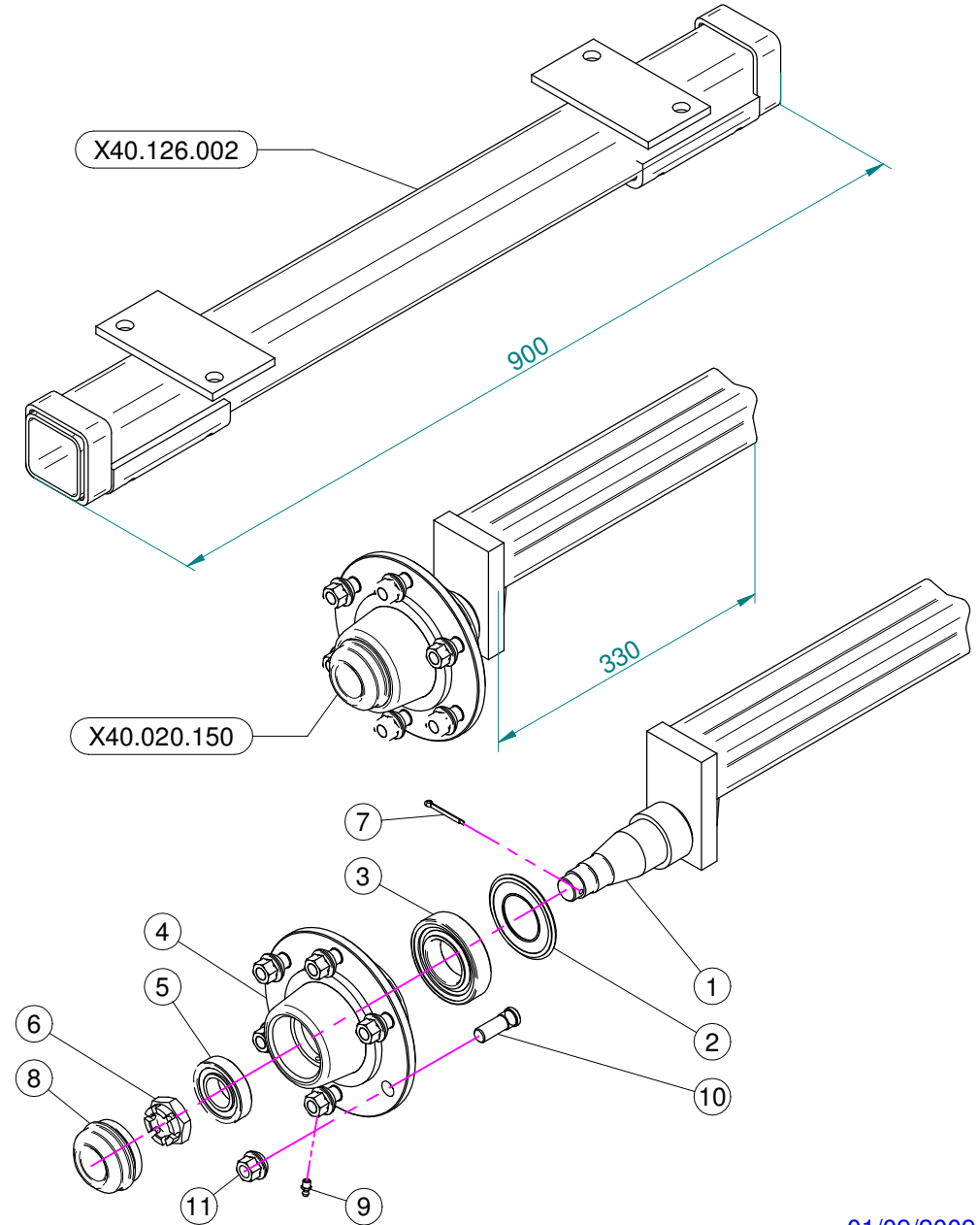

N°	Doc. Number	Titolo	Title	Q.tà	Note
1	X40.020.151	SEMIASSE A 6 COLONNETTE NON FORNITO	AXLE SHAFT NOT SUPPLYED	1	N.D.
2	X20.258.000	PARA-OLIO 45x85 IN GOMMA	OIL COVER	1	
3	XK0.030.209	CUSCINETTO A UNA CORONA DI RULLI CONICI	BEARING	1	
4	X05.903.001	MOZZI A 6 FORI GEARMORE	SIX HOLES FLANGE	1	N.D.
5	XK0.030.206	CUSCINETTO A UNA CORONA DI RULLI CONICI	BEARING	1	
6	XDI.027.5594F	DADO ESAGONALE A 6 INTAGLI	SIX CASTLE NUT M27	1	
7	X20.259.000	COPIGLIA D.4 L=45 PER MOZZI	SPLIT PIN	1	
8	X04.062.001	COPERCHIETTO DI CHIUSURA	COVER	1	
9	XID.006.001	INGRASSATORE DIRITTO M6	GREASER	1	
10	X05.911.001	COLONNETTA PER SEMIASSE M14x1.5	STUD	6	
11	X05.911.000	DADO PER COLONNETTA M14x1.5	SPECIAL NUT	6	

Gli esplosi elencati di seguito, sono relativi
a varianti od accessori a richiesta

Exploded drawings here listed, concern
variations or demanded accessories

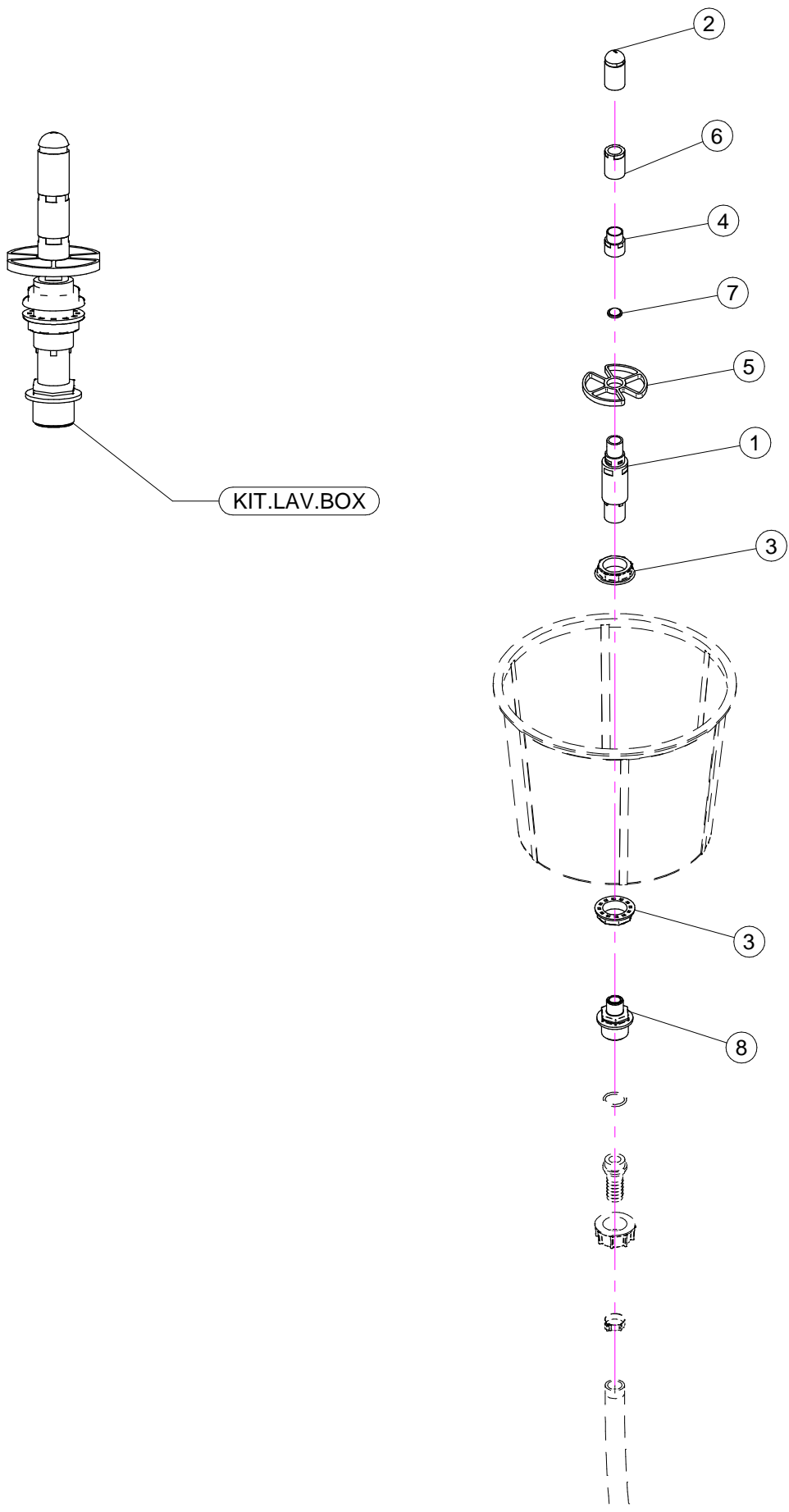

N°	Doc. Number	Titolo	Title	Q.tà	Note
1	X21.190.000	VALVOLA PER TESTINA LAVAGGIO CONTENITORI	VALVE FOR BOX WASH HEAD	1	
2	X21.191.000	TESTINA PER LAVAGGIO CONTENITORI	HEAD FOR BOX WASH	1	
3	X00.542.000	GHIERA 1"	NUT 1"	2	
4	X21.414.000	PORTAFILTRO	FILTER RING	1	
5	X21.411.000	FERMO BARATTOLO	BOX BLOCK	1	
6	X21.412.000	PORTA TESTINA PER LAVAGGIO CONTENITORI	HEAD BASE FOR BOX WASH	1	
7	X21.413.000	FILTRO PER LAVABARATTOLO	FILTER	1	
8	X21.410.000	NIPPLO 1/2M - 1M	NIPPLE 1/2M - 1M	1	

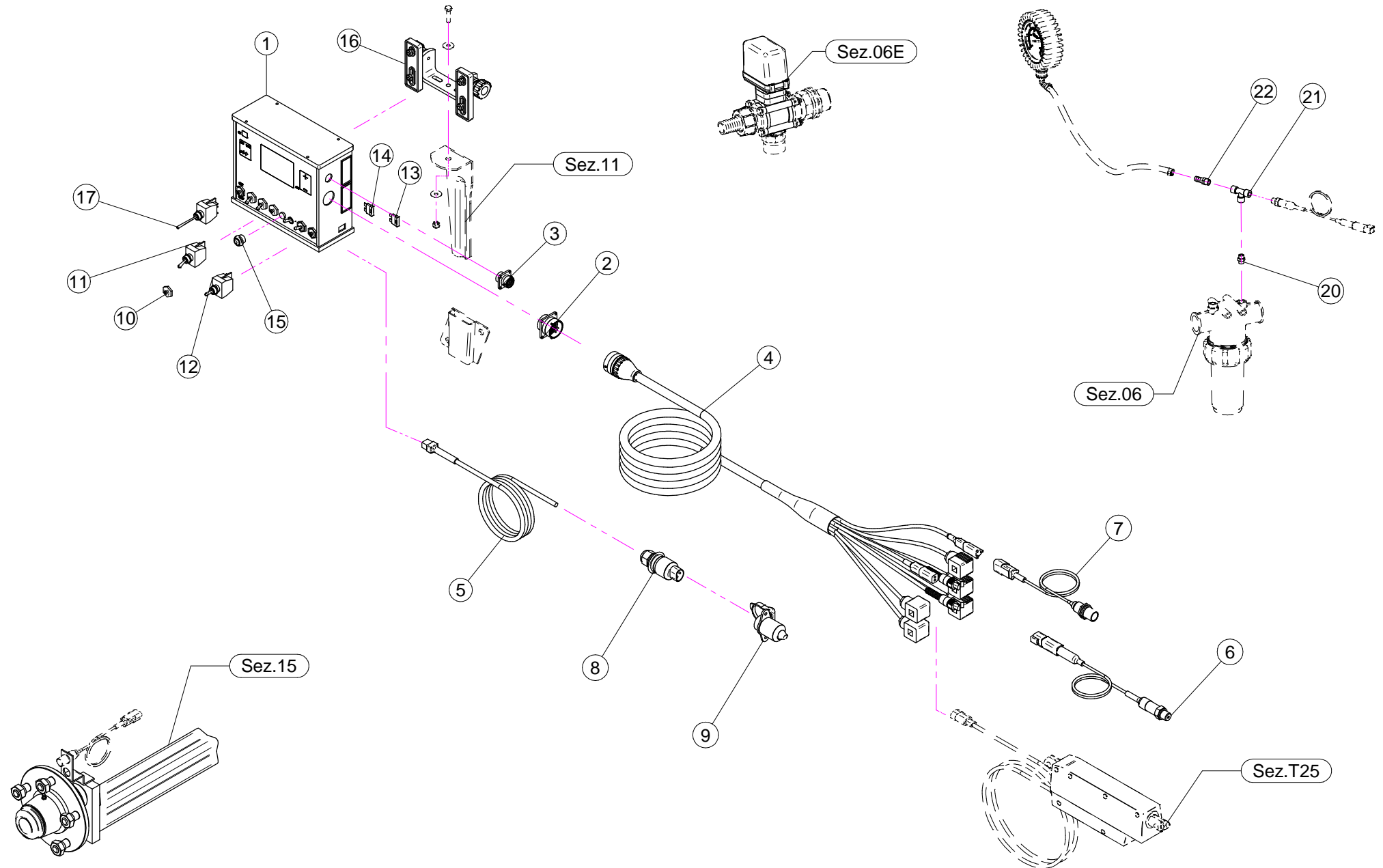

N°	Doc. Number	Titolo	Title	Q.tà	Note
1	X21.138.200	COMPUTER SERIE 844 AB	COMPUTER SERIES 844 AB	1	
2	X21.166.000	CONNETTORE BURNDY 28 PIN	BURNDY 28 PIN CONNECTOR	1	
3	X21.167.000	CONNETTORE BURNDY 8 PIN	BURNDY 8 PIN CONNECTOR	1	
4	X21.143.100	CAVO DATI COMPUTER 4VP+2AT-SP	COMPUTER DATA CABLE 4VP+2AT-SP	1	
5	X21.161.000	CAVO DI ALIMENTAZIONE COMPUTER	COMPUTER POWER WIRE	1	
6	X21.140.000	TRASDUTTORE DI PRESSIONE 0-10 BAR	PRESSURE TRANSDUCER	1	
7	X21.139.000	SENSORE DI VELOCITA' CL5X	SPEED SENSOR	1	
8	X21.162.000	SPINA DI ALIMENTAZIONE CAVO TRIPOLARE	POWER PLUG	1	
9	X21.163.000	PRESA DI ALIMENTAZIONE TRIPOLARE	POWER PLUG	1	
10	X21.030.007	CAPPUCCIO INTERRUTTORE D.12	SWITCH CAP D.12	7	
11	X21.030.005	DEVIATORE 2V 2P ON-OFF 10A	SWITCH 2V 2P ON-OFF 10A	5	
12	X21.030.006	DEVIATORE MOM - 0 - MOM 10A	SWITCH MOM - 0 - MOM 10A	1	
13	X21.030.004	FUSIBILE - 10 Ah	10 Ah FUSE	1	
14	X21.168.000	FUSIBILE - 5 Ah	5 Ah FUSE	1	
15	X21.170.000	INTERRUTTORE PULSANTE 2V 2P ON - OFF	PUSH-BUTTON SWITCH 2V 2P ON - OFF	1	
16	X21.165.000	STAFFA DI FISSAGGIO	BRACKET	1	
17	X21.030.018	DEVIATORE LUNGO 2V 2P ON-OFF 10A	LONG SWITCH 2V 2P ON-OFF 10A	1	

N°	Doc. Number	Titolo	Title	Q.tà	Note
20	X24.004.000	NIPPLO M/M 1/4"	NIPLES M/M 1/4"	1	
21	X21.172.000	RACCORDO A T 1/4" F/F/F	T FITTING 1/4" F/F/F	1	
22	X00.414.000	PORTAGOMMA D.11 1/4" M. FORATO	STRAIGHT HOSE D.11 1/4"	1	

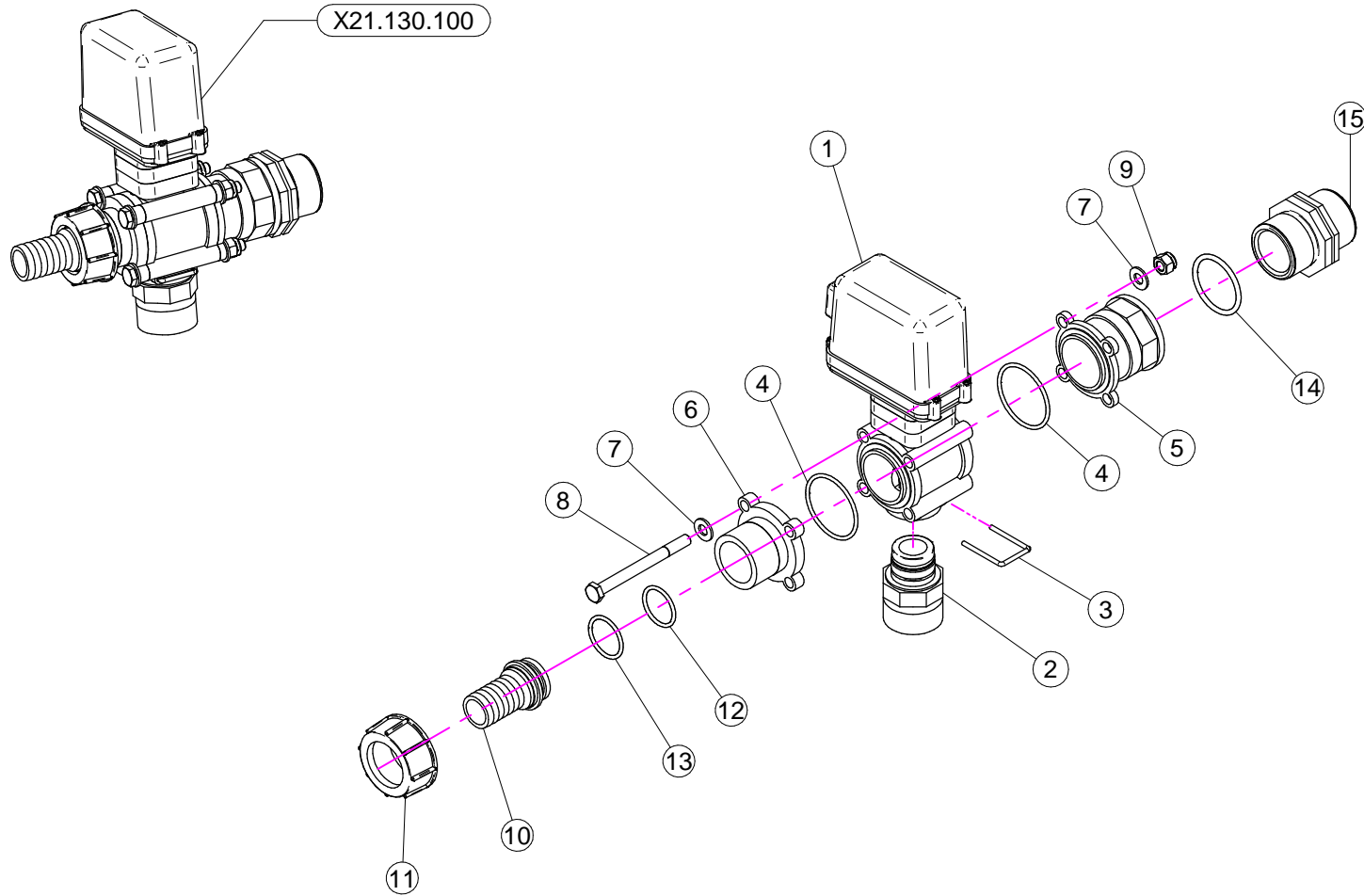

N°	Doc. Number	Titolo	Title	Q.tà	Note
1	X21.130.100	VALVOLA DI REGOLAZIONE PROPORZIONALE ELETTRICA VELOCE	QUICK ELECTRIC PROPORTIONAL VALVE	1	
2	X21.131.000	RIDUZIONE ATT.RAP. G 1" 1/4	REDUCTION J. F. G 1" 1/4	1	
3	X21.130.005	FORCHETTA ATTACCO RAPIDO	FORK FASTNER JOINT	1	
4	XOR.003.181	OR D. 45,69x50,93x2,62	45,69x50,93x2,62 O-RING	2	
5	X21.133.000	RACCORDO FLANGIATO 1" - 1 1/4"	CONNECTOR	1	
6	X21.132.000	FLANGIA VALVOLE	VALVE FLANGE	1	
7	XRP.008.000	RONDELLA PIANA D.8	WASHER D.8	8	
8	XTE.008.090	VITE TE M8 x 90	SCREW TE M8 x 90	4	
9	XDA.008.0AG	DADO AUTOBLOCCANTE M8	SELF LOCKING NUT M8	4	
10	X02.363.000	RACCORDO DIRITTO PG D.25 - 1 1/4	STRAIGHT HOSE R.H D.25 - 1 1/4	1	
11	X00.058.006	GIRELLO 1" 1/4 GAS	1" 1/4 FLY NUT	1	
12	XOR.003.106	OR D.26.65x2.62	O-RING D.26.65x2.62	1	
13	XOR.003.112	OR D.28,24x2,62	O-RING D.28,24x2,62	1	
14	XOR.000.144	OR D.39,69x3,53	O-RING D.39,69x3,53	1	
15	X00.345.010	NIPPLO 1" 1/4 + 1" 1/4 GAS	NIPPLE 1" 1/4 + 1" 1/4 GAS	1	

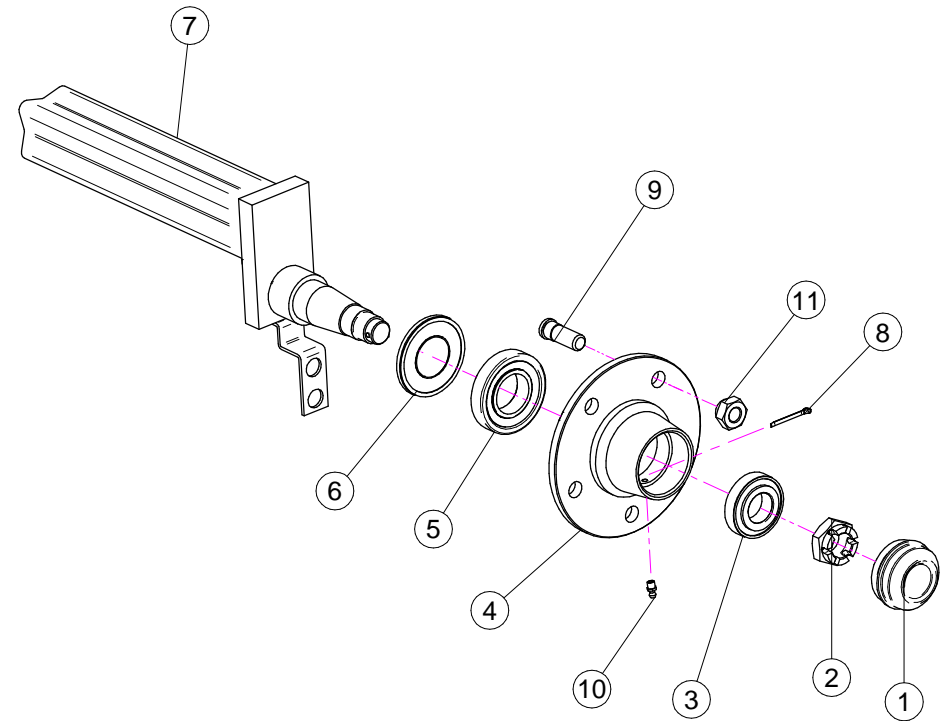
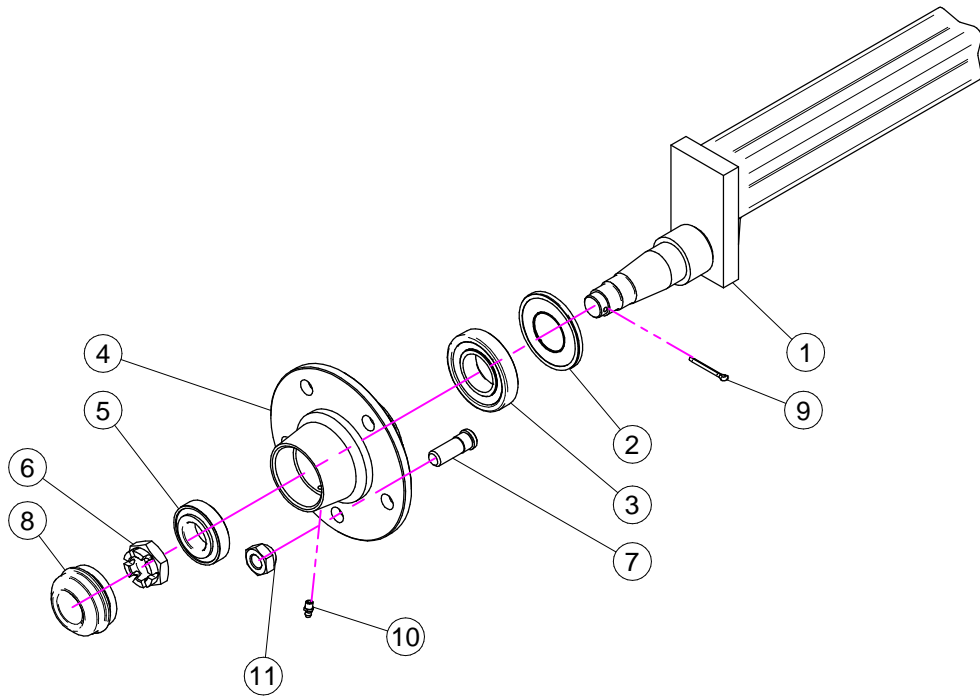
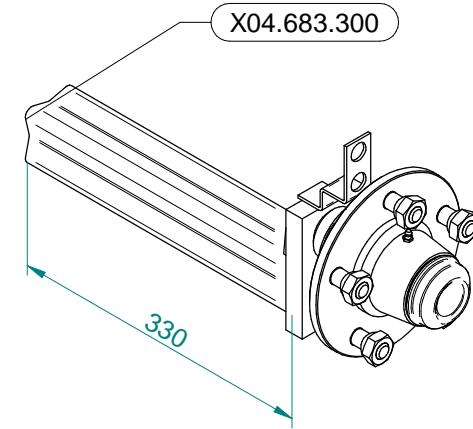
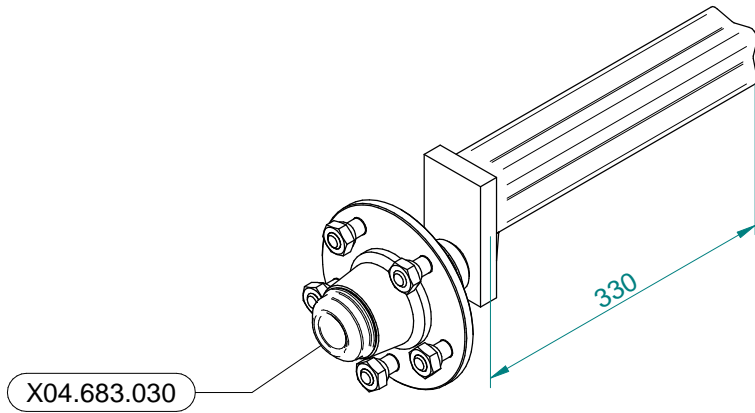

X04.683.030

N°	Doc. Number	Titolo	Title	Q.tà	Note
1	X04.683.006	SEMIASSE A 5 COLONNETTE	AXLE SHAFT	1	N.D.
2	X20.257.000	PARA - POLVERE D. 40x80 IN GOMMA	DUST SHIELDER	1	
3	XK0.030.208	CUSCINETTO A UNA CORONA DI RULLI CONICI	BEARING	1	
4	X04.683.003	FLANGIA MOZZI A 5 FORI	FIVE HOLES FLANGE	1	N.D.
5	XK0.030.206	CUSCINETTO A UNA CORONA DI RULLI CONICI 30206	BEARING	1	
6	XDI.027.5594F	DADO ESAGONALE A 6 INTAGLI	SIX CASTLE NUT M27	1	
7	X04.681.000	COLONNETTA PER SEMIASSE M16x1,5	STUD M16x1,5	5	
8	X04.062.001	COPERCHIETTO DI CHIUSURA	COVER	1	
9	X20.259.000	COPIGLIA D.4 L=45 PER MOZZI	SPLIT PIN	1	
10	XID.006.001	INGRASSATORE DIRITTO M6	GREASER	1	
11	X04.682.000	DADO PER COLONNETTA M 16x1.5	SPECIAL NUT	5	

X04.683.830

N°	Doc. Number	Titolo	Title	Q.tà
1	X04.062.001	COPERCHIETTO DI CHIUSURA	COVER	1
2	XDI.027.5594F	DADO ESAGONALE A 6 INTAGLI	SIX CASTLE NUT M27	1
3	XK0.030.206	CUSCINETTO A UNA CORONA DI RULLI CONICI 30206	BEARING	1
4	X04.683.003	FLANGIA MOZZI A 5 FORI	FIVE HOLES FLANGE	1
5	XK0.030.208	CUSCINETTO A UNA CORONA DI RULLI CONICI	BEARING	1
6	X20.257.000	PARA - POLVERE D. 40x80 IN GOMMA	DUST SHIELDER	1
7	X04.683.006	SEMIASSE A 5 COLONNETTE	AXLE SHAFT	1
8	X20.259.000	COPIGLIA D.4 L=45 PER MOZZI	SPLIT PIN	1
9	X04.681.000	COLONNETTA PER SEMIASSE M16x1,5	STUD M16x1,5	5
10	XID.006.001	INGRASSATORE DIRITTO M6	GREASER	1
11	X04.682.000	DADO PER COLONNETTA M 16x1.5	SPECIAL NUT	5

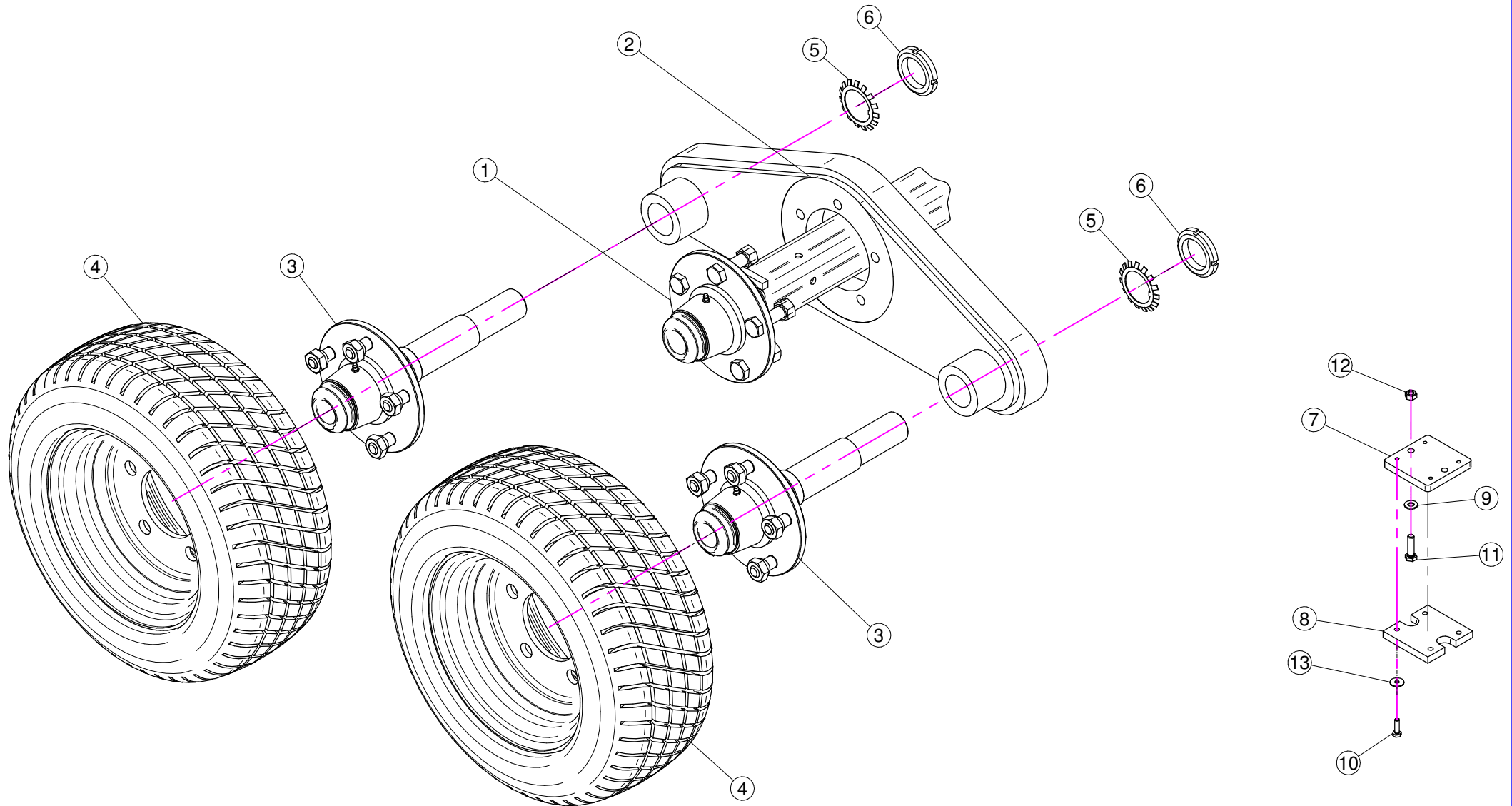

N°	Doc. Number	Titolo	Title	Q.tà	Note
1	X04.683.230	MOZZO A 5 COLONNETTE	WHEEL HUB	2	
2	X40.369.000	PIASTRA PORTA MOZZI RUOTE TANDEM	HUB SUPPORT SHEET	2	
3	X04.683.330	MOZZO A 5 COLONNETTE	WHEEL HUB	4	
4	X40.375.000	RUOTA 195/50 - 10 - 5Fori	TIRES	4	
5	XMB.009.000	ROSETTA DI SICUREZZA D.45	TOOTH LOCK WASHER	4	
6	XKM.009.000	GHIERA KM9	NUT KM9	4	
7	X40.373.001	SPESSORE FERMO RUOTE IN TANDEM	SPACER	4	
8	X40.374.001	SPESSORE IN GOMMA FERMO RUOTE IN TANDEM	SPACER	4	
9	XRP.008.000	RONDELLA PIANA D.8	WASHER D.8	16	
10	XTE.006.020T	VITE TE M6 x 20	SCREW TE M6 x 20	16	
11	XTE.008.030T	VITE TE M8x30	SCREW TE M8x30	8	
12	XD0.08.5588G	DADO M8 6S PG	M8 6S BIG LEAD NUT 5588	8	
13	XRP.006.018	RONDELLA PIANA D. 6x18	WASHER D.6x18	16	

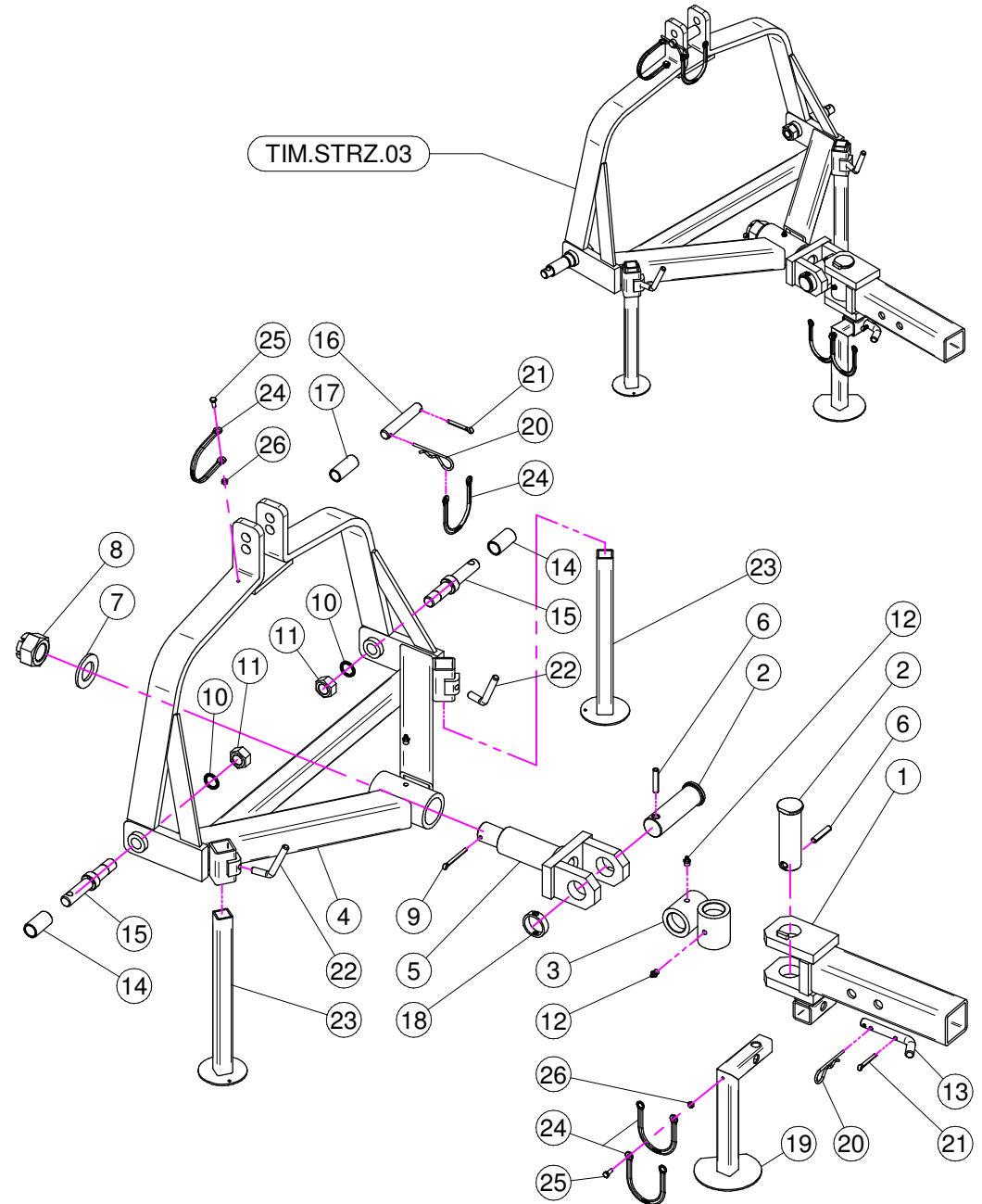
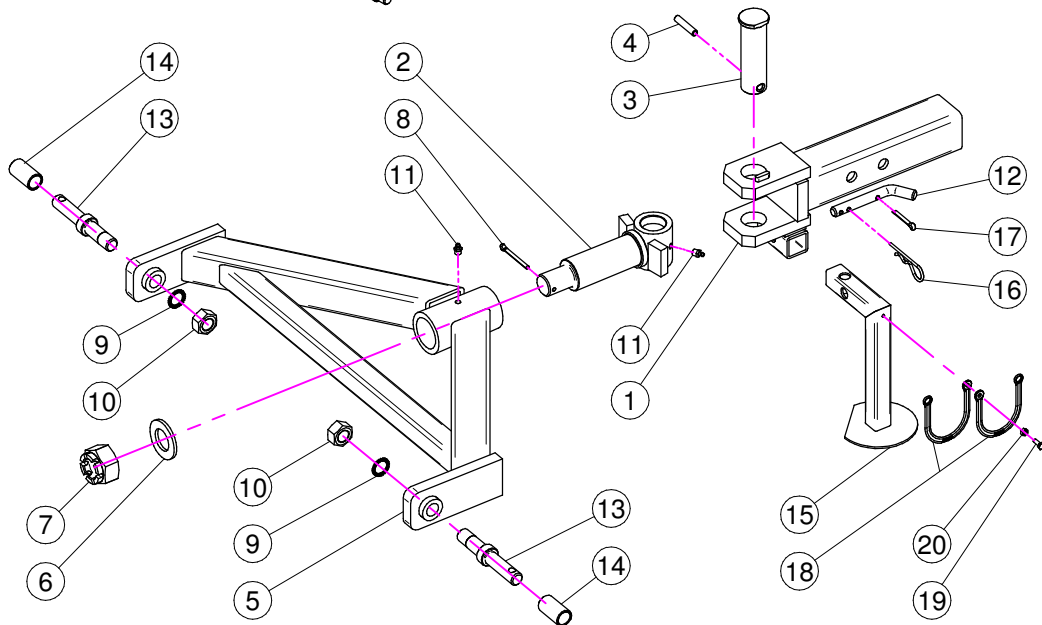
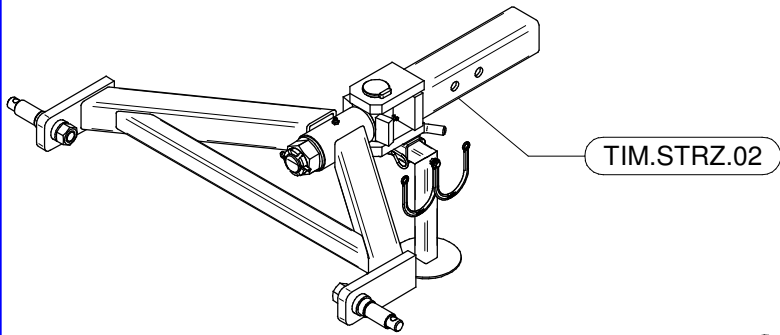
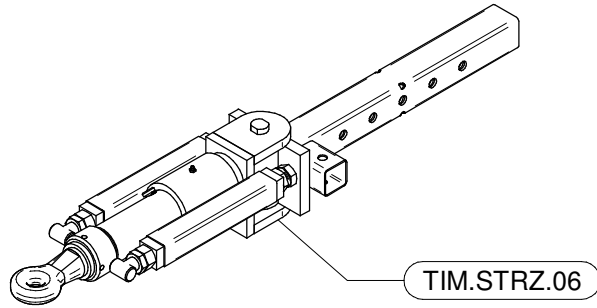

TIM.STRZ.02

N°	Doc. Number	Titolo	Title	Q.tà	Note
1	X40.153.001	TIMONE SNODATO - PARTICOLARE FISSO	DRAW-BAR - FIXING PARTICULAR	1	
2	X40.154.100	PERNO TIMONE STERZANTE A 2 PUNTI	PIN	1	
3	X40.150.000	PERNO PER TIMONE STERZANTE	PIN	1	
4	XSE.010.050	SPINA ELASTICA 10 x 50	SPRING PIN	1	
5	X40.152.000	CORPO A 2 PUNTI PER TIMONE STERZANTE	2 POINTS BODY	1	
6	XRP.036.000	RONDELLA PIANA Ø36	WASHER	1	
7	XDI.036.5593F	DADO AD INTAGLI M36	CASTLE NUT M30	1	
8	XCP.006.070	COPIGLIA	SPLIT PIN	1	
9	XRD.022.000	RONDELLA DENTELLATA D.22	TAB WASHER D.22	2	
10	XD0.22.5588F	DADO M22 x 1.5	NUT M22 x 1.5	2	
11	XID.010.001	INGRASSATORE DIRITTO M10X1	GREASE NIPPLE	2	
12	X20.505.000	SPINOTTO PIEDE D' APPOGGIO	PIN JACK STAND	1	
13	X04.064.100	SPINOTTO SOLLEVATORE	PIN POWER LIFT	2	
14	X40.202.000	BOCCOLA PER SPINOTTI SOLLEVATORE	BUSH	2	
15	X40.342.000	PIEDE D'APPOGGIO ESTRAIBILE	EXTRACTABLE JACK STAND	1	
16	X00.100.004	COPIGLIA D.4	SPLIT PIN D.4	1	
17	XCP.006.040I	COPIGLIA D.6 Lg.40	PIN D.6 Lg.40	1	
18	X21.183.000	STRISCIA FERMATAPPI	CAP STOP	2	
19	XTE.006.016T	VITE TE M6X16	SCREW TE M6X16	1	
20	XD0.06.5588G	DADO M6	NUT M6	1	

TIM.STRZ.03

N°	Doc. Number	Titolo	Title	Q.tà	Note
1	X40.153.001	TIMONE SNODATO - PARTICOLARE FISSO	DRAW-BAR - FIXING PARTICULAR	1	
2	X40.150.000	PERNO PER TIMONE STERZANTE	PIN	2	
3	X40.155.000	CROCERA PER TIMONE STERZANTE	JOINT	1	
4	X40.151.000	CORPO A 3 PUNTI PER TIMONE STERZANTE	3 POINTS BODY	1	
5	X40.154.000	PERNO PER TIMONE STERZANTE 3 PUNTI	PIN	1	
6	XSE.010.050	SPINA ELASTICA 10 x 50	SPRING PIN	2	
7	XRP.036.000	RONDELLA PIANA Ø36	WASHER	1	
8	XDI.036.5593F	DADO AD INTAGLI M36	CASTLE NUT M30	1	
9	XCP.006.070	COPIGLIA	SPLIT PIN	1	
10	XRD.022.000	RONDELLA DENTELLATA D.22	TAB WASHER D.22	2	
11	XD0.22.5588F	DADO M22 x 1.5	NUT M22 x 1.5	2	
12	XID.010.001	INGRASSATORE DIRITTO M10X1	GREASE NIPPLE	3	
13	X20.505.000	SPINOTTO PIEDE D' APPOGGIO	PIN JACK STAND	1	
14	X40.202.000	BOCCOLA PER SPINOTTI SOLLEVATORE	BUSH	2	
15	X04.064.100	SPINOTTO SOLLEVATORE	PIN POWER LIFT	2	
16	X04.076.000	SPINOTTO 3° PUNTO	PIN	1	
17	X20.778.000	BOCCOLA PER TERZO PUNTO PER PLUS	BUSH	1	
18	X40.363.000	DISTANZIALE	SPACER	1	
19	X40.342.000	PIEDE D'APPOGGIO ESTRAIBILE	EXTRACTABLE JACK STAND	1	
20	X00.100.004	COPIGLIA D.4	SPLIT PIN D.4	2	
21	XCP.006.040I	COPIGLIA D.6 Lg.40	PIN D.6 Lg.40	2	
22	X02.175.000	MANIGLIA DI BLOCCAGGIO	LOOKING HANDLE	2	
23	X40.251.200	PIEDE D'APPOGGIO	JACK	2	
24	X21.183.000	STRISCIA FERMATAPPI	CAP STOP	4	
25	XTE.006.016T	VITE TE M6X16	SCREW TE M6X16	2	
26	XD0.06.5588G	DADO M6	NUT M6	2	

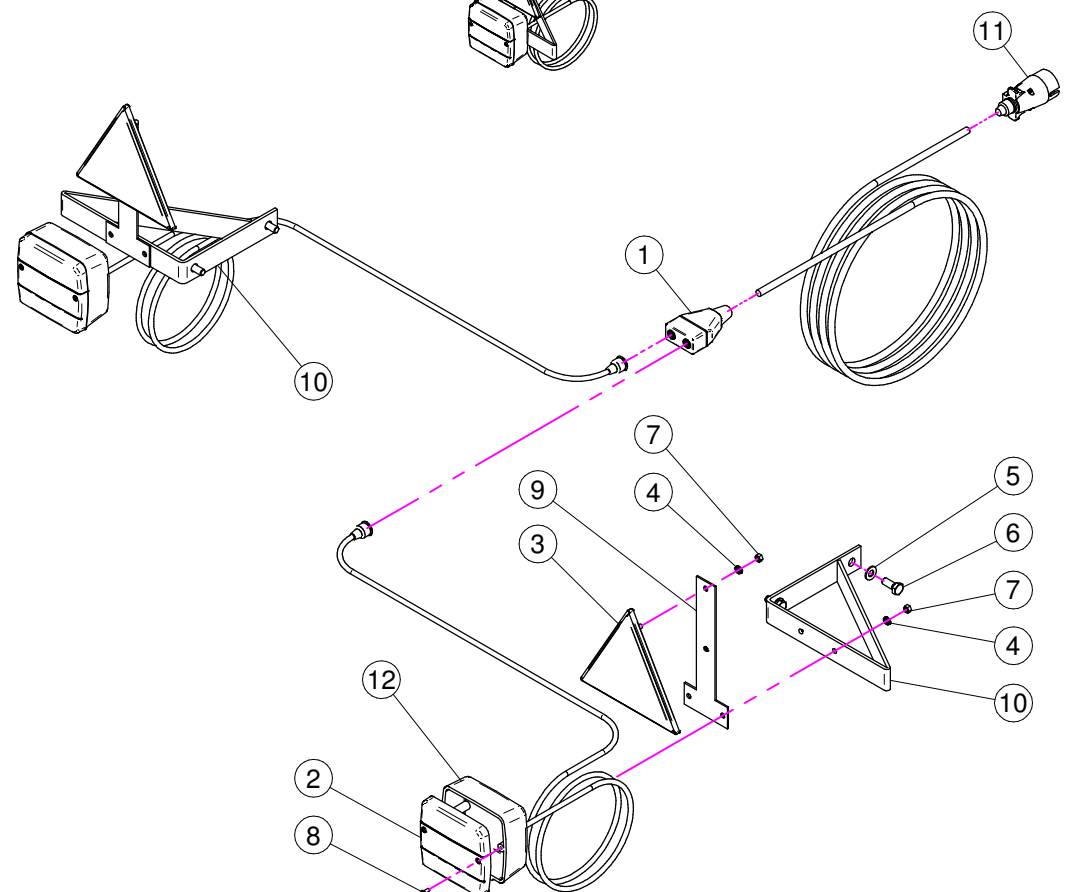
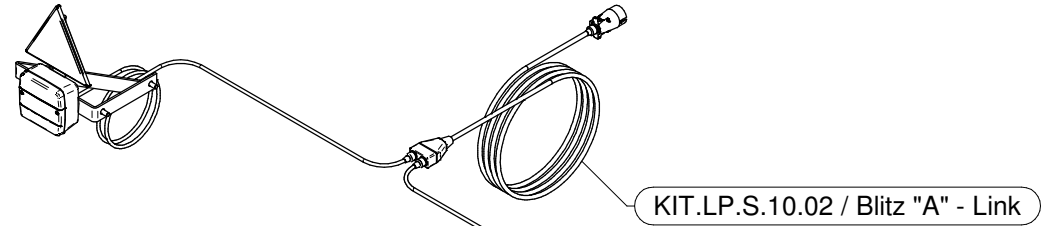
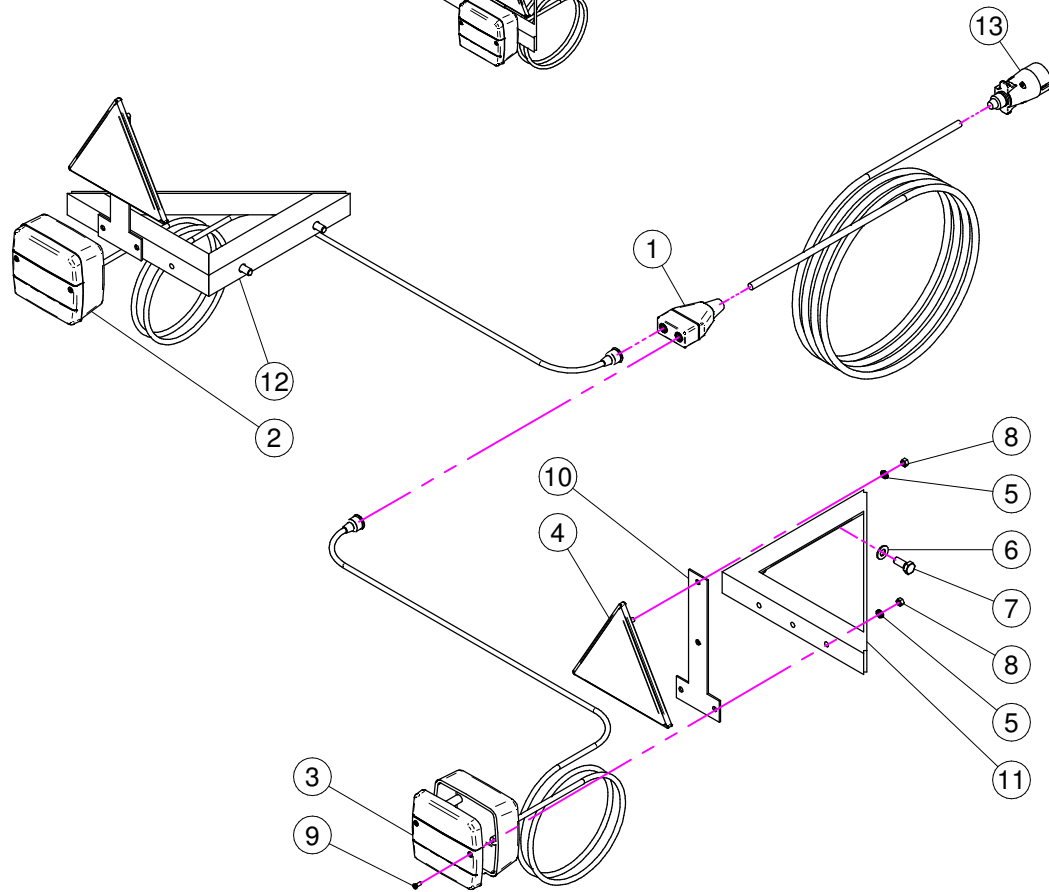
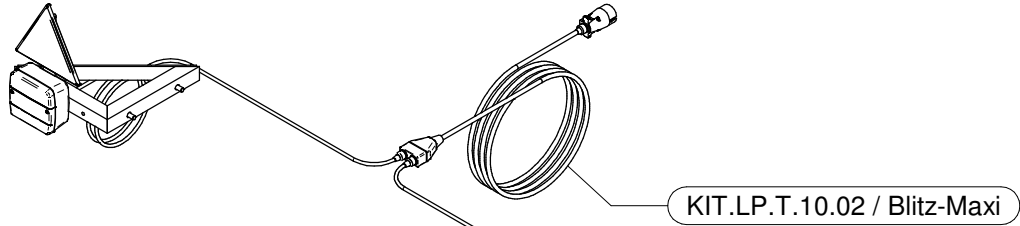

KIT.LP.T.10.02 (BLITZ-MAXI)

N°	Doc. Number	Titolo	Title	Q.tà	Note
1	X24.121.007	SCATOLA BLOCCO DIRAMAZIONI	ELECTRIC BOX	1	
2	X24.121.002	CORPO FANALE POSTERIORE 3F	BODY REAR LIGHT 3L	1	
3	X24.121.004	CATADIOTTRO FANALE POSTERIORE	REAR LIGHT REFLECTOR	2	
4	X24.121.001	CATADIOTTRO TRIANGOLARE	TRIANGULAR REFLECTOR	2	
5	XRD.005.000	RONDELLA DENTELLATA D.5	TAB WASHER D.5	8	
6	XRP.008.000	RONDELLA PIANA D.8	WASHER D.8	4	
7	XTE.008.020T	VITE TE 8x20	SCREW TE 8x20	4	
8	XD0.05.5587G	DADO M5 PG 5587	M5 PG 5587 NUT	8	
9	XTA.03,5.09,5I	VITE AUTOFILETTANTE D.3,5 x 9,5	SELF THREADING D.3,5 x 9,5	4	
10	X40.341.000	STAFFA	BRACKET	2	
11	X40.340.200	STAFFA DX	BRACKET DX	1	
12	X40.340.100	STAFFA SX	BRACKET SX	1	
13	X24.121.006	SPINA	PLUG	1	

KIT.LP.S.10.02 (BLITZ "A" - LINK)

N°	Doc. Number	Titolo	Title	Q.tà	Note
1	X24.121.007	SCATOLA BLOCCO DIRAMAZIONI	ELECTRIC BOX	1	
2	X24.121.004	CATADIOTTRO FANALE POSTERIORE	REAR LIGHT REFLECTOR	2	
3	X24.121.001	CATADIOTTRO TRIANGOLARE	TRIANGULAR REFLECTOR	2	
4	XRD.005.000	RONDELLA DENTELLATA D.5	TAB WASHER D.5	8	
5	XRP.008.000	RONDELLA PIANA D.8	WASHER D.8	4	
6	XTE.008.020T	VITE TE 8x20	SCREW TE 8x20	4	
7	XD0.05.5587G	DADO M5 PG 5587	M5 PG 5587 NUT	8	
8	XTA.03,5.09,5I	VITE AUTOFILETTANTE D.3,5 x 9,5	SELF THREADING D.3,5 x 9,5	4	
9	X40.341.000	STAFFA	BRACKET	2	
10	X40.340.000	STAFFA	BRACKET	2	
11	X24.121.006	SPINA	PLUG	1	
12	X24.121.002	CORPO FANALE POSTERIORE 3F	BODY REAR LIGHT 3L	1	

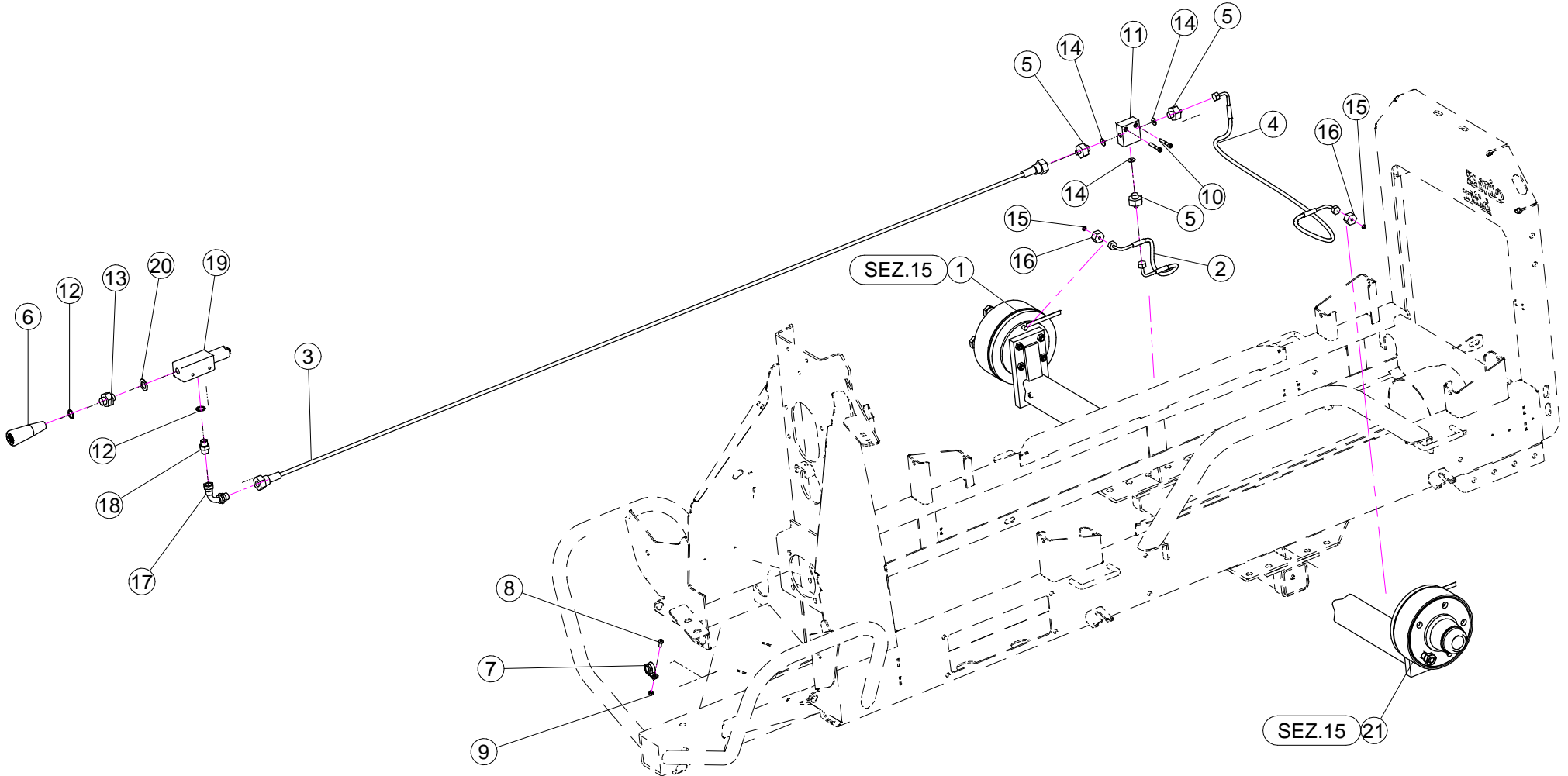

N°	Doc. Number	Titolo	Title	Q.tà
1	X04.683.500	SEMIASSE A 5 COLONNETTE CON FRENO MONTATO SU BLITZ	WHEEL HUB	1
2	X21.341.060	TUBO OLIO 1/4" L=600 CON RACCORDI	OIL HOSE 1/4" L=600 WITH FITTINGS	1
3	X21.341.350	TUBO OLIO 1/4" L=3500 CON RACCORDI	OIL HOSE 1/4" L=3500 WITH FITTINGS	1
4	X21.341.100	TUBO OLIO 1/4" L=1000 CON RACCORDI	OIL HOSE 1/4" L=1000 WITH FITTINGS	1
5	X21.342.000	NIPPLO DOPPIO 1/4" 1/4"	DOUBLE NIPLES 1/4" 1/4"	3
6	X21.343.000	INNESTO FASTER	CLUTCH	1
7	XFG.018.000	FASCETTA GOMMATA PER TUBI D.18	STICKER	1
8	XTCC.06.16	VITE TESTA A CROCE M6x16	CROSS SLOTTED SCREW M6x16	1
9	XDOT.06.5587	DADO OTTONE M6	M6 BRASS NUT 5587	1
10	XTCE.006 .040	VITE BRUGOLA TCE M6x40	BOLT TCE M6x40	2
11	X21.348.000	DISTRIBUTORE OLIO PER FRENO	BRAKE OIL DISTRIBUTOR	1
12	X21.344.000	RONDELLA RAME D.18x1,5	COPPER WASHER D.18x1,5	2
13	X21.345.000	NIPPLO RIDOTTO 3/8 - m18	NIPLES 3/8 - M18	1
14	X21.349.000	RONDELLA RAME D.1/4	COPPER WASHER D.1/4	3
15	X21.346.000	RONDELLA RAME D.10x1,5	COPPER WASHER D.10x1,5	2
16	X21.347.000	RACCORDO RAD 1803	RAD 1803 FITTING	2
17	X21.381.000	CURVA PER OLIO 3/8 M - 3/8 F	OIL BEND 3/8 M - 3/8 F	1
18	X21.107.000	NIPPLO 3/8M - 3/8M	NIPLES 3/8M - 3/8M	1
19	X21.382.000	VALVOLA MASSIMA PRESSIONE OLIO 60 bar	MAXIMUM PRESSURE OIL VALVE 60 bar	1
20	X21.362.000	RONDELLA RAME D.30x18x1,5	COPPER WASHER D.30x18x1,5	1
21	X04.683.700	SEMIASSE A 5 COLONNETTE CON FRENO	WHEEL HUB	1

SEMIASSE SINISTRO

X04.683.700

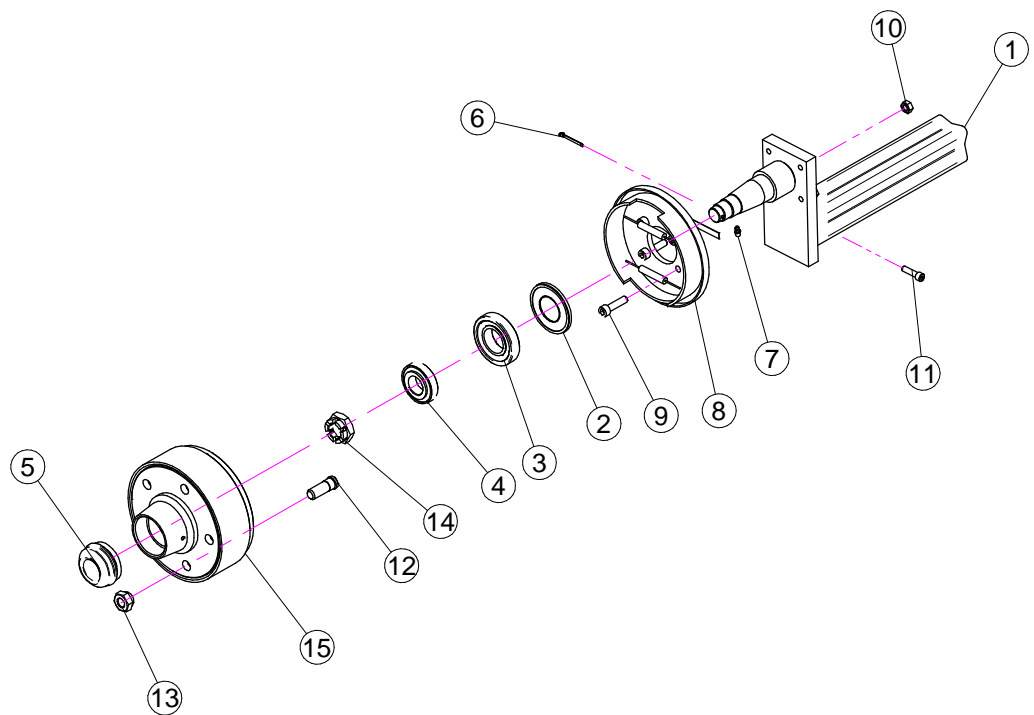
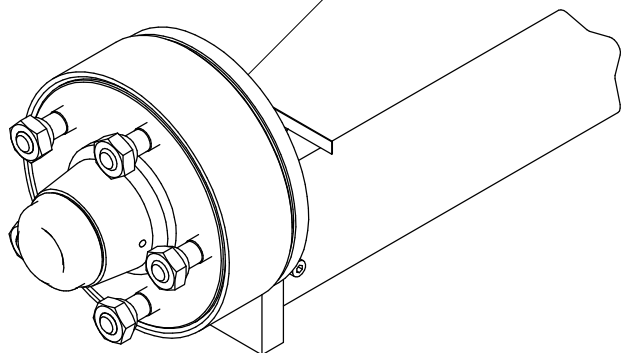

SEMIASSE DESTRO

X04.683.500

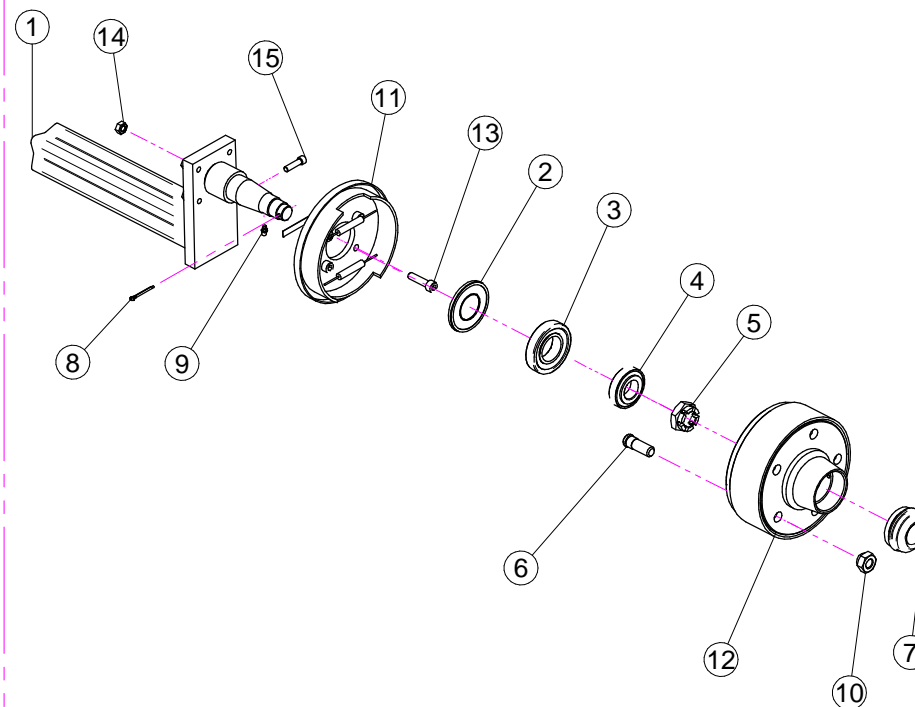
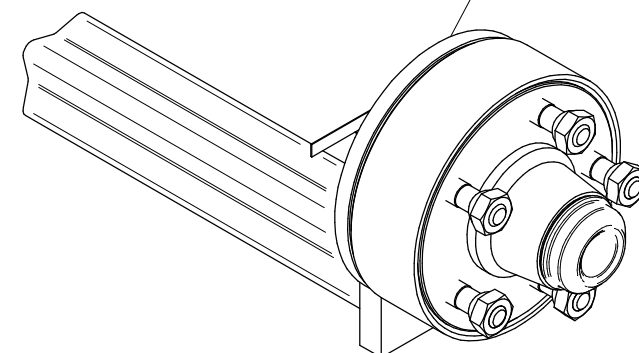

X04.683.700

X04.683.500

N°	Doc. Number	Titolo	Title	Q.tà
1	X04.683.501	SEMIASSE A 5 COLONNETTE ALLUNGATO PER FRENO	AXLE SHAFT	1
2	X20.257.000	PARA - POLVERE D. 40x80 IN GOMMA	DUST SHIELDER	1
3	XK0.030.208	CUSCINETTO A UNA CORONA DI RULLI CONICI	BEARING	1
4	XK0.030.206	CUSCINETTO A UNA CORONA DI RULLI CONICI 30206	BEARING	1
5	X04.062.001	COPERCHIETTO DI CHIUSURA	COVER	1
6	X20.259.000	COPIGLIA D.4 L=45 PER MOZZI	SPLIT PIN	1
7	XID.006.001	INGRASSATORE DIRITTO M6	GREASER	1
8	X40.388.000	FRENO SX COMPLETO	LEFT BRAKE	1
9	XTCE.010.040	VITE TESTA CIL. CON ESAGONO INCASSATO	HEXAGON SOCKET HEAD SCREW M10 x 40	1
10	XD0.10.5588G	DADO M 10 6S PG	M10 6S BIG LEAD NUT 5588	1
11	XTCE.008.030	VITE BRUGOLA TCE M8x30	BOLT TCE M8x30	1
12	X04.681.000	COLONNETTA PER SEMIASSE M16x1,5	STUD M16x1,5	1
13	X04.682.000	DADO PER COLONNETTA M 16x1.5	SPECIAL NUT	1
14	XDI.027.5594F	DADO ESAGONALE A 6 INTAGLI	SIX CASTLE NUT M27	1
15	X04.200.100	TAMBURO PER FRENO	BRAKE DRUM	1

N°	Doc. Number	Titolo	Title	Q.tà
1	X04.683.501	SEMIASSE A 5 COLONNETTE ALLUNGATO PER FRENO	AXLE SHAFT	1
2	X20.257.000	PARA - POLVERE D. 40x80 IN GOMMA	DUST SHIELDER	1
3	XK0.030.208	CUSCINETTO A UNA CORONA DI RULLI CONICI	BEARING	1
4	XK0.030.206	CUSCINETTO A UNA CORONA DI RULLI CONICI 30206	BEARING	1
5	XDI.027.5594F	DADO ESAGONALE A 6 INTAGLI	SIX CASTLE NUT M27	1
6	X04.681.000	COLONNETTA PER SEMIASSE M16x1,5	STUD M16x1,5	5
7	X04.062.001	COPERCHIETTO DI CHIUSURA	COVER	1
8	X20.259.000	COPIGLIA D.4 L=45 PER MOZZI	SPLIT PIN	1
9	XID.006.001	INGRASSATORE DIRITTO M6	GREASER	1
10	X04.682.000	DADO PER COLONNETTA M 16x1.5	SPECIAL NUT	5
11	X40.389.000	FRENO DX COMPLETO	RIGHT BRAKE	1
12	X04.200.100	TAMBURO PER FRENO	BRAKE DRUM	1
13	XTCE.010.040	VITE TESTA CIL. CON ESAGONO INCASSATO	HEXAGON SOCKET HEAD SCREW M10 x 40	4
14	XD0.10.5588G	DADO M 10 6S PG	M10 6S BIG LEAD NUT 5588	4
15	XTCE.008.030	VITE BRUGOLA TCE M8x30	BOLT TCE M8x30	1

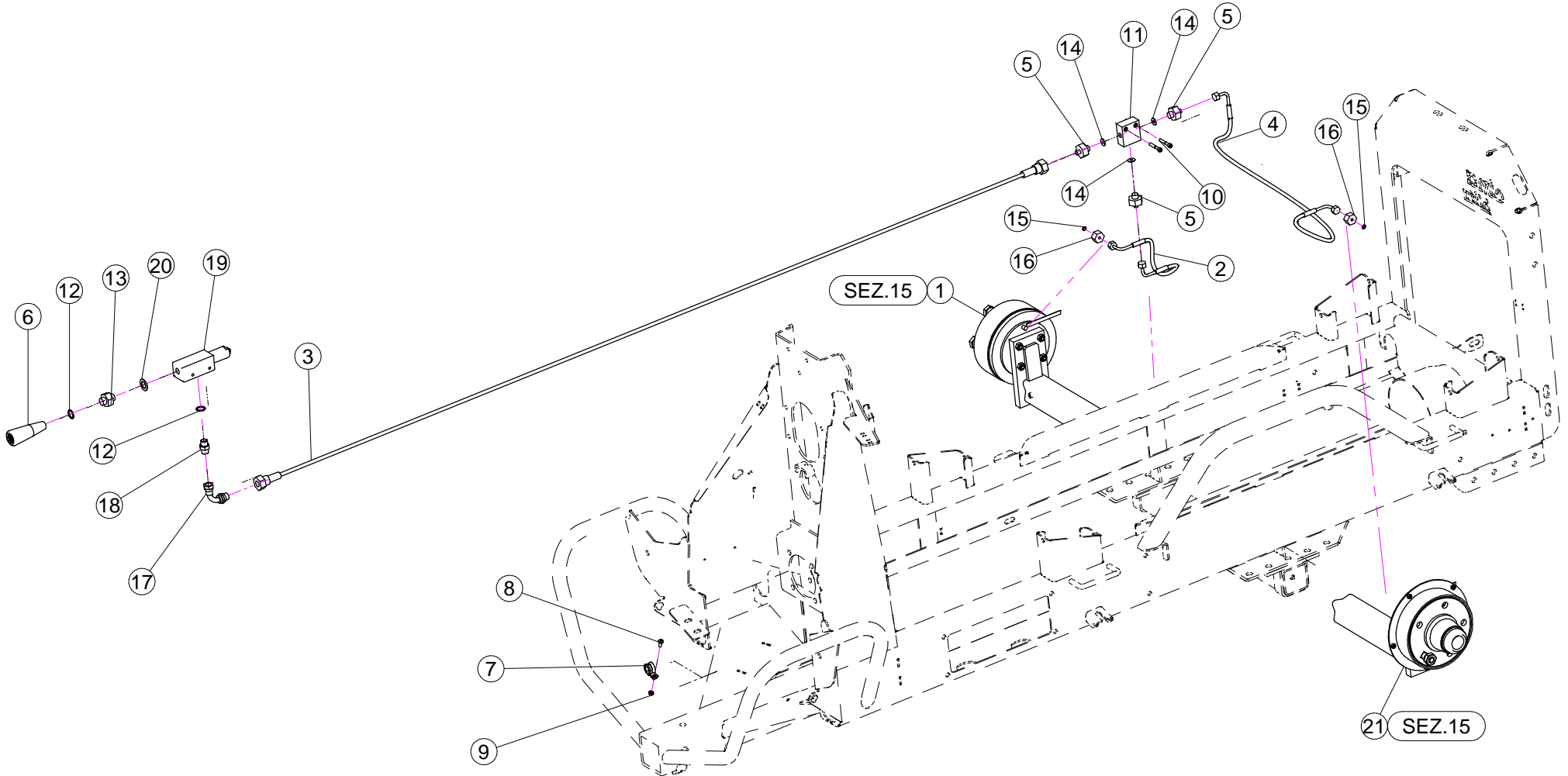

N°	Doc. Number	Titolo	Title	Q.tà
1	X04.683.500	SEMIASSE A 5 COLONNETTE CON FRENO MONTATO SU BLITZ	WHEEL HUB	1
2	X21.341.060	TUBO OLIO 1/4" L=600 CON RACCORDI	OIL HOSE 1/4" L=600 WITH FITTINGS	1
3	X21.341.350	TUBO OLIO 1/4" L=3500 CON RACCORDI	OIL HOSE 1/4" L=3500 WITH FITTINGS	1
4	X21.341.100	TUBO OLIO 1/4" L=1000 CON RACCORDI	OIL HOSE 1/4" L=1000 WITH FITTINGS	1
5	X21.342.000	NIPPLO DOPPIO 1/4" 1/4"	DOUBLE NIPLES 1/4" 1/4"	3
6	X21.343.000	INNESTO FASTER	CLUTCH	1
7	XFG.018.000	FASCETTA GOMMATA PER TUBI D.18	STICKER	1
8	XTCC.06.16	VITE TESTA A CROCE M6x16	CROSS SLOTTED SCREW M6x16	1
9	XDOT.06.5587	DADO OTTONE M6	M6 BRASS NUT 5587	1
10	XTCE.006 .040	VITE BRUGOLA TCE M6x40	BOLT TCE M6x40	2
11	X21.348.000	DISTRIBUTORE OLIO PER FRENO	BRAKE OIL DISTRIBUTOR	1
12	X21.344.000	RONDELLA RAME D.18x1,5	COPPER WASHER D.18x1,5	2
13	X21.345.000	NIPPLO RIDOTTO 3/8 - m18	NIPLES 3/8 - M18	1
14	X21.349.000	RONDELLA RAME D.1/4	COPPER WASHER D.1/4	3
15	X21.346.000	RONDELLA RAME D.10x1,5	COPPER WASHER D.10x1,5	2
16	X21.347.000	RACCORDO RAD 1803	RAD 1803 FITTING	2
17	X21.381.000	CURVA PER OLIO 3/8 M - 3/8 F	OIL BEND 3/8 M - 3/8 F	1
18	X21.107.000	NIPPLO 3/8M - 3/8M	NIPLES 3/8M - 3/8M	1
19	X21.382.000	VALVOLA MASSIMA PRESSIONE OLIO 60 bar	MAXIMUM PRESSURE OIL VALVE 60 bar	1
20	X21.362.000	RONDELLA RAME D.30x18x1,5	COPPER WASHER D.30x18x1,5	1
21	X04.683.400	SEMIASSE A 5 COLONNETTE CON FRENO	WHEEL HUB	1

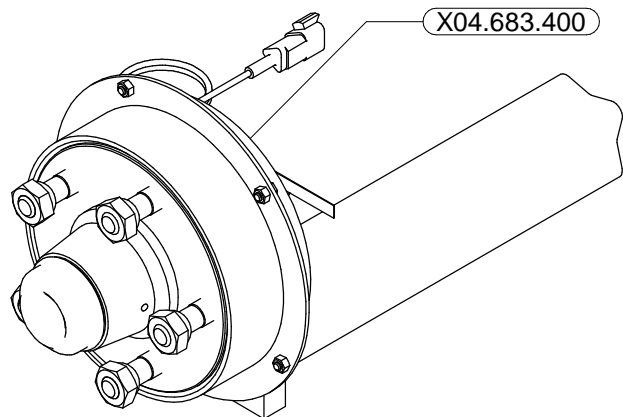

SEMIASSE SINISTRO

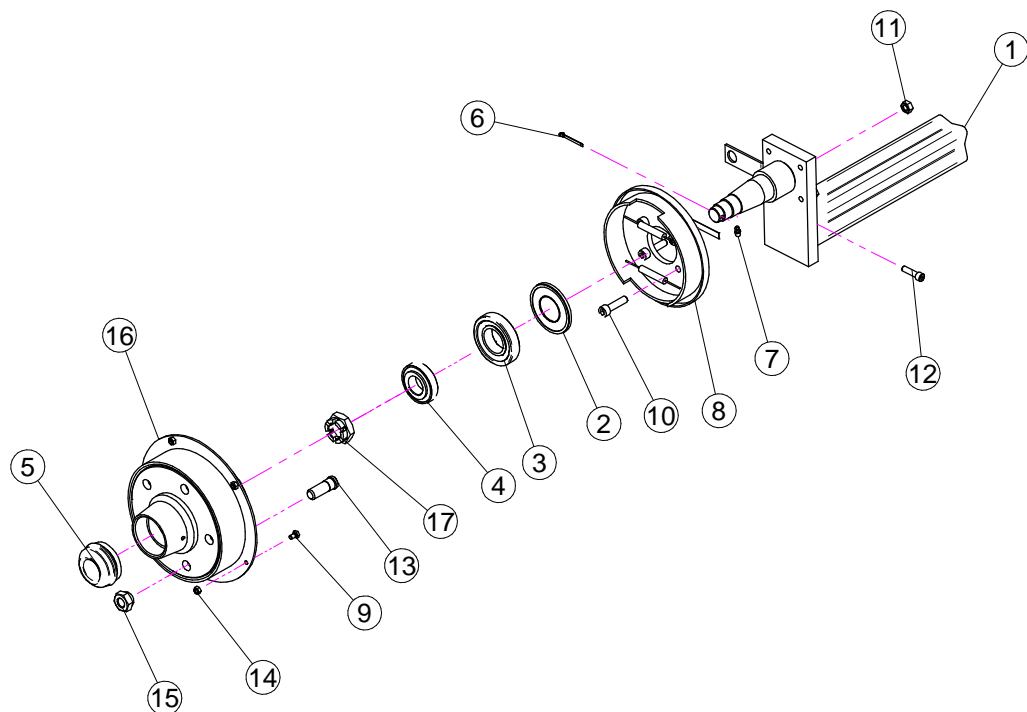

SEMIASSE DESTRO

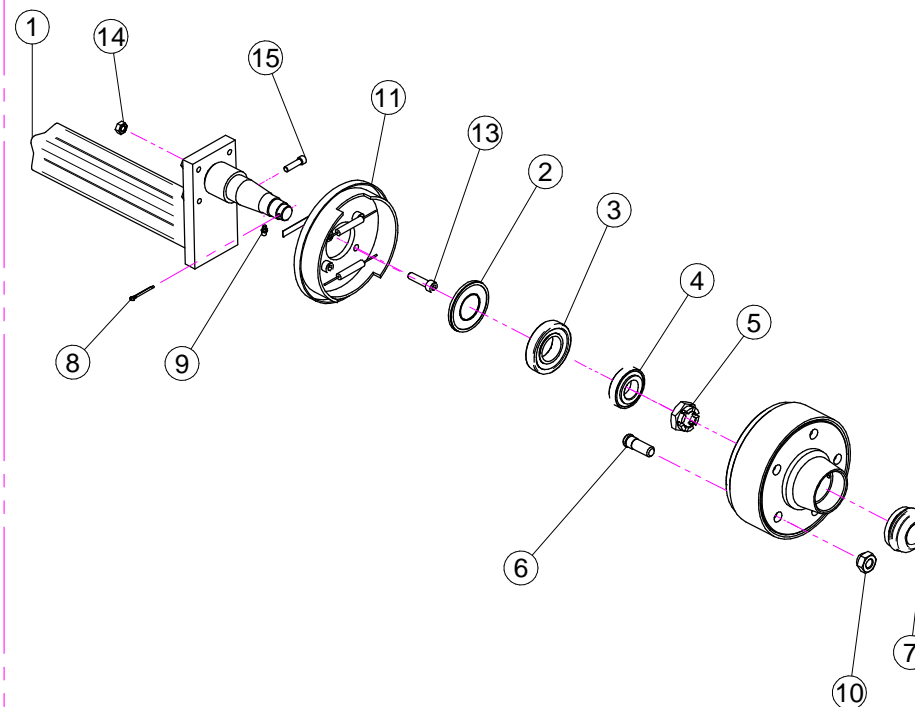
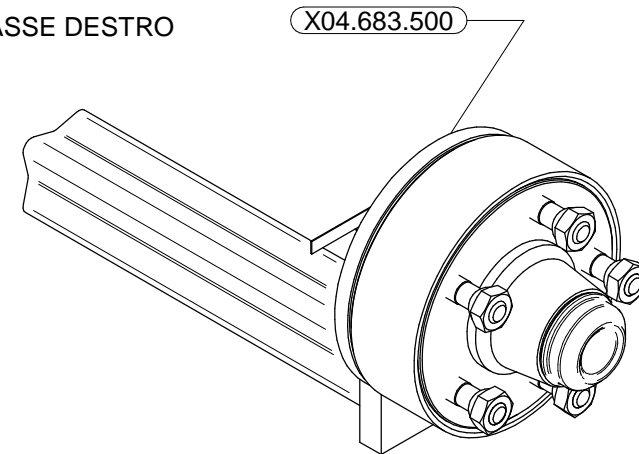

X04.683.400

X04.683.500

N°	Doc. Number	Titolo	Title	Q.tà
1	X04.683.401	SEMIASSE A 5 COLONNETTE ALLUNGATO PER FRENO ED EPA	AXLE SHAFT	1
2	X20.257.000	PARA - POLVERE D. 40x80 IN GOMMA	DUST SHIELDER	1
3	XK0.030.208	CUSCINETTO A UNA CORONA DI RULLI CONICI	BEARING	1
4	XK0.030.206	CUSCINETTO A UNA CORONA DI RULLI CONICI 30206	BEARING	1
5	X04.062.001	COPERCHIETTO DI CHIUSURA	COVER	1
6	X20.259.000	COPIGLIA D.4 L=45 PER MOZZI	SPLIT PIN	1
7	XID.006.001	INGRASSATORE DIRITTO M6	GREASER	1
8	X40.388.000	FRENO SX COMPLETO	LEFT BRAKE	1
9	XTE.006.010T	VITE TE M6x10	SCREW TE M6x10	1
10	XTCE.010.040	VITE TESTA CIL. CON ESAGONO INCASSATO	HEXAGON SOCKET HEAD SCREW M10 x 40	1
11	XD0.10.5588G	DADO M 10 6S PG	M10 6S BIG LEAD NUT 5588	1
12	XTCE.008.030	VITE BRUGOLA TCE M8x30	BOLT TCE M8x30	1
13	X04.681.000	COLONNETTA PER SEMIASSE M16x1,5	STUD M16x1,5	1
14	XD0.06.5588G	DADO M6	NUT M6	1
15	X04.682.000	DADO PER COLONNETTA M 16x1.5	SPECIAL NUT	1
16	X04.200.000	TAMBURO PER FRENO E EPA	BRAKE DRUM	1
17	XDI.027.5594F	DADO ESAGONALE A 6 INTAGLI	SIX CASTLE NUT M27	1

N°	Doc. Number	Titolo	Title	Q.tà
1	X04.683.501	SEMIASSE A 5 COLONNETTE ALLUNGATO PER FRENO	AXLE SHAFT	1
2	X20.257.000	PARA - POLVERE D. 40x80 IN GOMMA	DUST SHIELDER	1
3	XK0.030.208	CUSCINETTO A UNA CORONA DI RULLI CONICI	BEARING	1
4	XK0.030.206	CUSCINETTO A UNA CORONA DI RULLI CONICI 30206	BEARING	1
5	XDI.027.5594F	DADO ESAGONALE A 6 INTAGLI	SIX CASTLE NUT M27	1
6	X04.681.000	COLONNETTA PER SEMIASSE M16x1,5	STUD M16x1,5	5
7	X04.062.001	COPERCHIETTO DI CHIUSURA	COVER	1
8	X20.259.000	COPIGLIA D.4 L=45 PER MOZZI	SPLIT PIN	1
9	XID.006.001	INGRASSATORE DIRITTO M6	GREASER	1
10	X04.682.000	DADO PER COLONNETTA M 16x1.5	SPECIAL NUT	5
11	X40.389.000	FRENO DX COMPLETO	RIGHT BRAKE	1
12*	X04.200.100	TAMBURO PER FRENO	BRAKE DRUM	1
13	XTCE.010.040	VITE TESTA CIL. CON ESAGONO INCASSATO	HEXAGON SOCKET HEAD SCREW M10 x 40	4
14	XD0.10.5588G	DADO M 10 6S PG	M10 6S BIG LEAD NUT 5588	4
15	XTCE.008.030	VITE BRUGOLA TCE M8x30	BOLT TCE M8x30	1