

Sez. 23 (a)
Timone Sterzante
Steering Drawbar

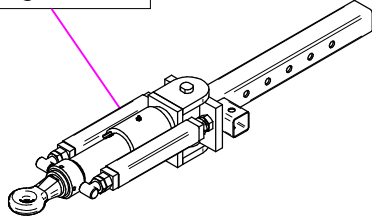

Sez. 23 (a)
Timone Sterzante a 3 punti
Steering Drawbar 3 points

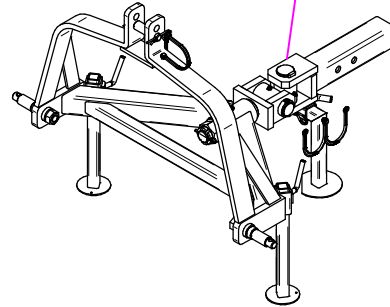

Sez. 23 (a)
Timone Sterzante a 2 punti
Steering Drawbar 2 points

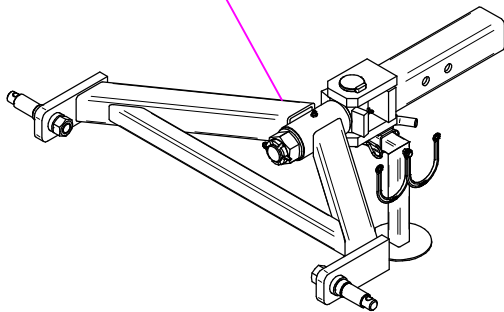

Sez.06E (a)
Elettrovalvola Regolazione Pressione
Solenoid Valves Regulation Pressure

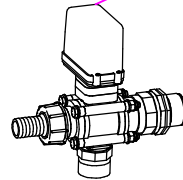

Sez.22 (a)
Tubazione Riempimento
Filling pipe

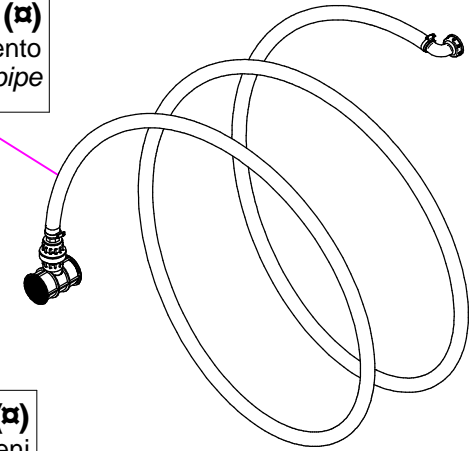

Sez.15A (a)
Freni
Brakes

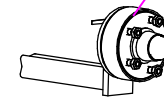

Sez.02E (a)
Kit Lava barattoli
Container Washing
Device Kit

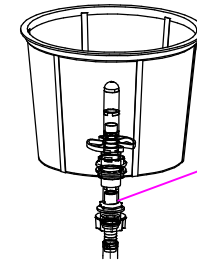

Sez. 01 (a)
Ruota d'appoggio estraibile
Extractable wheel

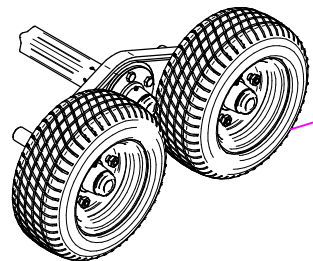
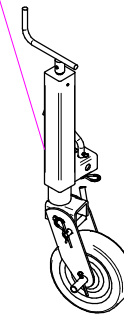

Sez.14 (a)
Ruote in Tandem
Tandem Wheels

Sez. 01 (a)
Pedana di salita removibile
Footboard

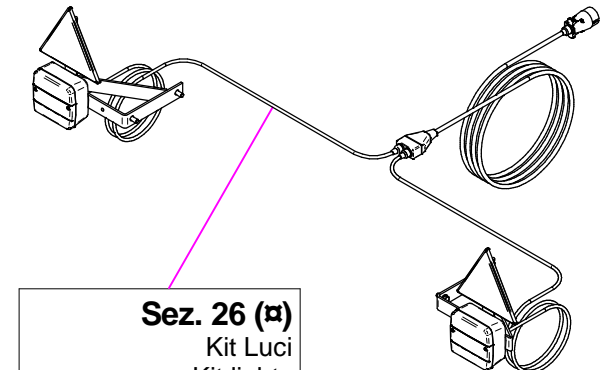
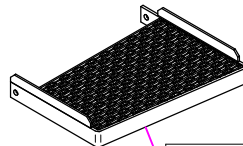

Sez. 26 (a)
Kit Luci
Kit lights

(a) A richiesta / Optional Devices

N°	Doc. Number	Titolo	Title	Q.tà	Note
1	X40.136.200	TIMONE "TIPO USA"	DRAW-BAR "TIPO USA"	1	
2	XRP.018.000	RONDELLA PIANA D.18	WASHER	2	
3	XTE.018.120	VITE TE M18 x 120	SCREW TE M18 x 120	1	
4	XDA.018.0AG	DADO AUTOBLOCCANTE M18x2.5	SELF LOCKING NUT M18	1	
5	XTE.014.030T	VITE TE M14x30	SCREW TE M14x30	6	
6	X40.146.100	CERCHIO DI PROTEZIONE	BUMPER	1	
7	XRP.010.000	RONDELLA PIANA D.10	WASHER D.10	14	
8	XTE.010.035T	VITE TE 10 x 35	SCREW TE 10 x 35	4	
9	XD0.10.5587G	DADO M10	NUT M10	5	
10	X20.409.000	SUPPORTO PER CARDANO	SHAFT SUPPORT	1	
11	XRP.008.024	RONDELLA PIANA LARGA D.8X24	WASHER D.8X24	11	
12	XTE.008.100	VITE TE M8 x 100	SCREW TE M8 x 100	1	
13	XDA.008.0AG	DADO AUTOBLOCCANTE M8	SELF LOCKING NUT M8	2	
14	X20.616.001	STAFFA FERMA SERBATOIO	BRACKET	2	
15	X40.147.000	GUARNIZIONE PER TUNNEL BLITZ 45-50	GASKET FOR TUNNEL 45-50	1	
16	XRP.010.030	RONDELLA PIANA D.10 x 30 mm	WASHER D.10 x 30 mm	11	
17	XTE.010.025T	VITE TE 10x25T	SCREW TE 10x25T	1	
18	XTE.008.020T	VITE TE 8x20	SCREW TE 8x20	2	
19	XD0.08.5588G	DADO M8	NUT M8	2	
20	X20.532.000	PIATTO BLOCCAGGIO CARTER	FRONT HOUSING BLOCKING PLATE	1	
21	X20.533.100	RONDELLA SPECIALE Ø 100 SP 10 mm	SPECIAL WASHER Ø 100 SP 10 mm	1	
22	XRD.006.000	RONDELLA DENTELLATA D.6	TAB WASHER D.6	9	
23	XTE.006.025T	VITE TE M6X25	SCREW TE M6X25	3	
24	XD0.06.5588G	DADO M6	NUT M6	6	
25	X40.302.200	LAMIERA D'APPOGGIO SERBATOIO	PLATE TANK SUPPORT	1	
26	XTE.008.025T	VITE TE 8X25	SCREW TE M8X25	4	
27	XTE.012.050T	VITE TE M12x50T	SCREW M12X50T	1	
28	XTE.012.040T	VITE TE M12X40 UNI 5739	BOLT TE M12X40	1	
29	X40.129.010	ASSALE	AXLE	1	
30	X04.691.000	ASSIEME MOZZO A 6 COLONNETTE	HUB	2	
31	XD0T.12.5587	DADO OTTONE M12	M12 BRASS NUT	2	
32	XRP.012.000	RONDELLA PIANA D. 12	WASHER D. 12	6	
33	X02.964.000	MOLLA PER POMPA CD 32	CD 32 PUMP SPRING	2	
34	XDA.012.0AG	DADO AUTOBLOCCANTE M12	NUT M12	2	
35	XMT.012.000	MOLLA A TAZZA D. 12	WASHER D.12	2	
36	XTE.014.040T	VITE TE M14 x 40	SCREW TE M14 x 40	4	
37*	X02.978.000SX	SUPPORTO POMPA TIPO NUOVO	BRACKET	2	
38	XD0.14.5587G	DADO M14	NUT M14	4	
39	XID.006.001	INGRASSATORE DIRITTO M6	GREASER	1	
40	X20.447.000	TENDICINGHIA M12 PER POMPA	BELT STRETCHER FOR PUMP	2	
41	X20.531.000	LAMIERA FISSAGGIO CARTER	CARTER FIXING PLATE	1	

N°	Doc. Number	Titolo	Title	Q.tà	Note
42	XRP.008.032	RONDELLA PIANA LARGA D.8X32	WASHER D.8X32	1	
43	XTE.008.030T	VITE TE M8x30	SCREW TE M8x30	1	
44	X40.311.000	SQUADRETTA FISSAGGIO TUBAZIONI	BRACKET	1	
45	X05.615.000	CURVA D.175 90°	ELBOW D.175 90°	1	
46	X05.616.000	COLLARE PER TUBI D.175	PIPE CLAMP D.175	3	
47	XTE.010.030T	VITE TE M10 x 30	SCREW TE M10 x 30	5	
48	XRP.014.000	RONDELLA PIANA D.14	WASHER D.14	8	
49	X40.122.100	TUNNEL PASSAGGIO ARIA	AIR WAY TUNNEL	1	
50	XD0.10.5587G	DADO M10	NUT M10	4	
51	X50.280.000	STAFFA FISSAGGIO SERBATOIO	BRACKET	2	
52	XTE.008.035T	VITE TE M8x35	SCREW TE M8x35	4	
53	X02.440.000	CONTROCUFFIA D.210 PER CARDANO	SHAFT CONE D.210	1	
54	X04.993.070C	PIEDE D'APPOGGIO ESTRAIBILE	EXTRACTABLE JACK STAND	1	
55	X04.866.160	CARTER ANTERIORE BLITZ 45 2 POMPE	FAN HOUSING 2 PUMPS	1	
56	XTE.008.016T	VITE TE M8x16	SCREW TE M8x16	2	

N°	Doc. Number	Titolo	Title	Q.tà	Note
57	X04.993.070	CORPO PIEDE D'APPOGGIO	JACK STAND BODY	1	
58	X20.505.000	SPINOTTO PIEDE D' APPOGGIO	PIN JACK STAND	1	
59	X00.100.004	COPIGLIA D.4	SPLIT PIN D.4	1	
60	XCP.006.040I	COPIGLIA D.6 Lg.40	PIN D.6 Lg.40	1	
61	X21.183.000	STRISCIA FERMATAPPI	CAP STOP	2	
62	XTE.006.016T	VITE TE M6X16	SCREW TE M6X16	1	
63	XD0.06.5588G	DADO M6	NUT M6	1	

OPTIONAL

N°	Doc. Number	Titolo	Title	Q.tà	Note
80	X05.727.400C	RUOTA D'APPOGGIO ESTRAIBILE	EXTRACTABLE WHEEL	1	

N°	Doc. Number	Titolo	Title	Q.tà	Note
81	X05.727.400	CORPO RUOTA D'APPOGGIO	SUPPORT WHEEL	1	
82	X00.100.004	COPIGLIA D.4	SPLIT PIN D.4	1	
83	X20.505.000	SPINOTTO PIEDE D' APPOGGIO	PIN JACK STAND	1	
84	XTE.006.016T	VITE TE M6X16	SCREW TE M6X16	1	
85	XCP.006.040I	COPIGLIA D.6 Lg.40	PIN D.6 Lg.40	1	
86	X21.183.000	STRISCIA FERMATAPPI	CAP STOP	2	
87	XD0.06.5588G	DADO M6	NUT M6	1	

N°	Doc. Number	Titolo	Title	Q.tà	Note
1	X02.404.100	FILTRO A TAZZA 400 x 330	BASKET FILTER 400 x 330	1	
2	X02.298.000	FILTRO A TAZZA D.204	BASKET FILTER D.204	1	
3	X02.476.100	COPERCHIO FILETTATO D.255 CON FILO	THREADED LID D.255 WITH ROPE	1	
4	X20.512.000	STAFFA ANCORAGGIO FASCE	BRACKET	6	
5	X20.513.000	PIASTRINA SERRAGGIO FASCE	SHAPED PLATE	6	
6	XTE.006.020T	VITE TE M6 x 20	SCREW TE M6 x 20	12	
7	XRP.006.000	RONDELLA PIANA D. 6	WASHER D.6	12	
8*	XDA.006.0AG	DADO AUTOBLOCCANTE M6	SELF LOCKING NUT M6	12	
9	XRP.010.000	RONDELLA PIANA D.10	WASHER D.10	6	
10	XTE.010.080T	VITE M10x80	M10x80 BOLT	6	
11	XDOT.10.5587	DADO OTTONE M10	M10 BRASS NUT	7	
12	X02.135.000	VALVOLA A PISTONCINO COMPLETA	COMPLETE PISTON VALVE	1	
13	XFC.023.5.025	FASCETTA COBRA 23,5 - 25	KOBRA CLAMP 23,5 - 25	1	
14	X02.032.000	GUARNIZIONE D.26x40 SP. 2	GASKET D.26x40 SP. 2	1	
15	X00.541.000	GHIERA 3/4"	NUT 3/4"	1	
16	X00.131.000	PRESA ANTIVORTICE 1"	1" VORTIX DAMPER DRIVE	1	
17	X00.055.021	RACCORDO DIRITTO PG D.25	STRAIGHT HOSE R.H D.25	1	
18	XOR.000.132	OR D.23,81 x 2,62	23,81 x 2,62 O-RING GASKET	1	
19	X00.055.24.2	GIRELLO 1" GAS	1" FLY NUT	2	
20	XF0.023.035I	FASCETTA A VITE 23/35 W4 INOX	STAINLESS STEEL CLIP	2	
21	X20.793.000	RACCORDO DIRITTO P.G. D.25 3/4" GAS M.	HOSETAIL R.H. D.25 3/4" GAS M.	1	
22	X00.055.038	RACCORDO CURVO A P.G. D.19	CURVED UNION WITH R.H. D.19	1	
23	X20.608.000	TUBO FORATO 1" L=1700	PERFORATED HOSE 1" L=1700	1	
24	XTF.001.000	TAPPO 1"	PACKING	1	
25	XOR.003.112	OR D.28,24x2,62	O-RING D.28,24x2,62	2	

N°	Doc. Number	Titolo	Title	Q.tà	Note
26	X00.058.028	RACCORDO DIRITTO PG D. 30	STRAIGHT HOSE R.H D.30	1	
27	X00.058.006	GIRELLO 1" 1/4 GAS	1" 1/4 FLY NUT	1	
28	XF0.025.040I	FASCETTA A VITE 25/40 W4 INOX	STAINLESS STEEL CLIP	6	
29	X02.339.000	RACCORDO CURVO A 45° CON P.G. D.30	45° HOSETAIL	1	
30	X02.481.253	FASCIA IN NYLON 60 mm L=2530	NYLON BAND 60 mm L=2530	1	
31	X02.481.280	FASCIA IN NYLON 60 mm L=2800	NYLON BAND 60 mm L=2800	2	
32	X02.355.000	FASCETTA D'ASSEMBLAGGIO 292 mm	NYLON ASSEMBLY CLAMP	3	
33	XFC.022.5.024	FASCETTA COBRA 22,5 - 24	KOBRA CLAMP 22,5 - 24	1	
34	X02.212.090	TUBO D. 19x25 L= 900	HOSE D. 19x25 L= 900	1	
35	X02.238.170	TUBO SPIRALATO D. 30 L= 1700	HOSE D. 30 L= 1700	1	
36	X02.372.130	TUBO SPIRALATO D. 19 L= 1300	HOSE D. 19 L= 1300	1	
37	X02.238.160	TUBO SPIRALATO D. 30 L= 1600	HOSE D. 30 L= 1600	1	
38	X20.610.000	STAFFA FISSAGGIO FRANGI ONDA	BRACKET FIXING BREAKWATER	1	
39	XDA.010.0BGI	DADO AUTOBLOCCANTE M10	SELF LOCKING NUT M10	1	
40	XTSCE.010.040TI	VITE A TESTA SVASATA M10 x 40	SCREW M10 x 40	1	
41	XD0.10.5587GI	DADO M10	NUT M10	4	
42	XTE.010.030I	VITE TE M10x30 INOX	INOX M10x30 SCREW	4	
43	X20.609.000	FRANGI ONDA BLITZ 1500-2000	BREAKWATER	1	
44	XRP.010.00I	RONDELLA PIANA D.10 INOX	WASHER D.10 INOX	8	
45	X00.493.000	GIRELLO 1" 1/4 GAS	1" 1/4 FLY NUT	1	
46	XTE.006.060I	VITE TE M6x60 INOX	INOX M6x60 TE SCREW	6	
47	XDC.06.5721I	DADO DIN 1587 6x1-6-10	NUT DIN 1587 6x1-6-10	6	
48	X00.542.000	GHIERA 1"	NUT 1"	1	
49	XOR.003.106	OR D.26.65x2.62	O-RING D.26.65x2.62	1	
50	X20.809.140	TUBO D.25 CON RAMINO L=1400	HOSE D.25 L=1400	1	

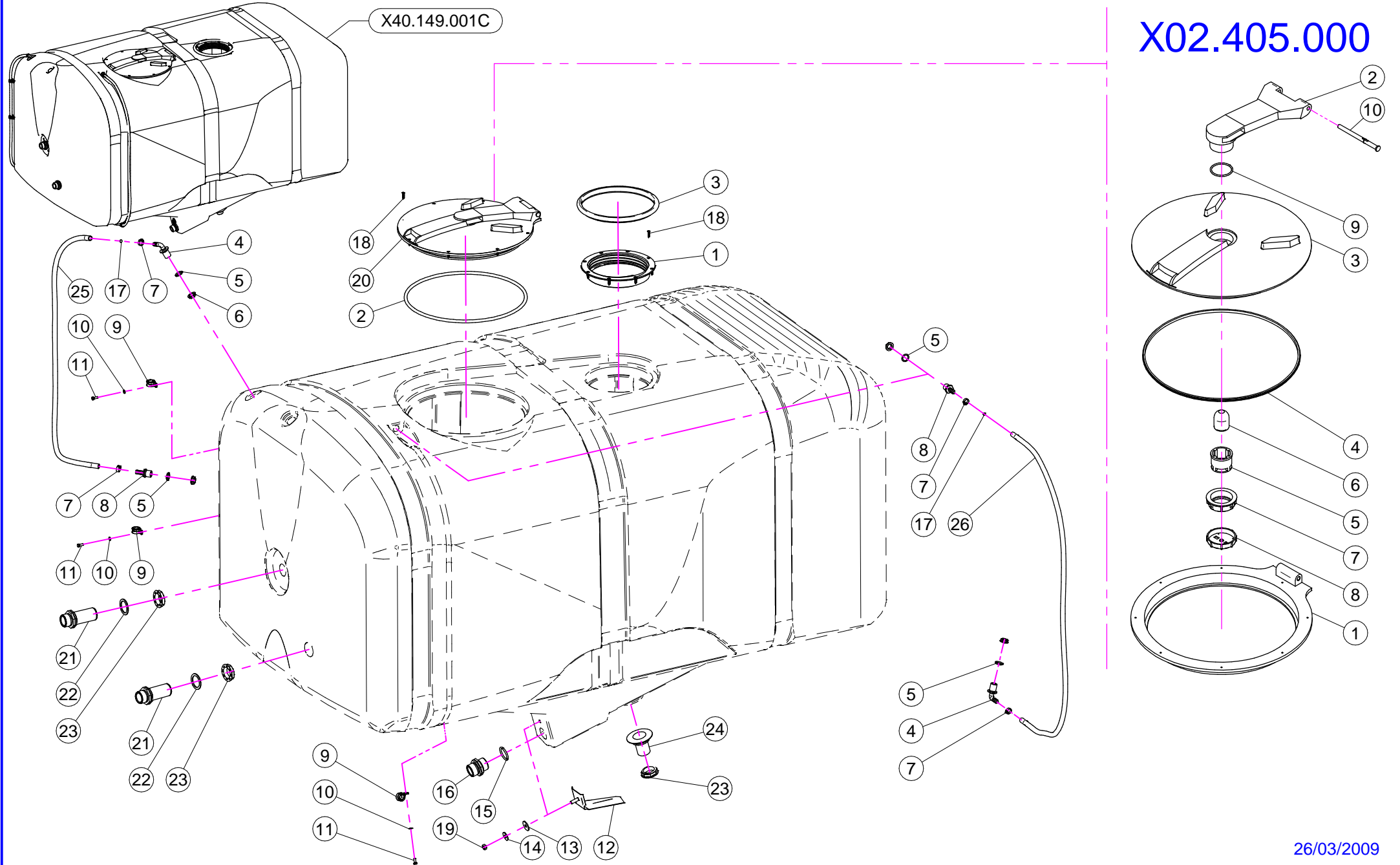

N°	Doc. Number	Titolo	Title	Q.tà	Note
1	X02.477.000	ANELLO FILETTATO D.255	THREATED RING D.255	1	
2	X02.405.000.L	GUARNIZIONE	GASKET	1	
3	X02.477.000.A	GUARNIZIONE PER ANELLO FILETTATO D.255	THREATED RING GASKET D.255	1	
4	X02.457.000	PORTAGOMMA D.13 A 90° M. 1/2"	HOSETAIL D.13 90° M. 1/2"	2	
5	XOR.004.081	OR D.20,22 x 3,53	20,22 x 3,53 O-RING GASKET	4	
6	X02.458.000	GHIERA 1/2"	LOCK RING 1/2"	4	
7	XFC.016,5.018	FASCETTA COBRA 16,5 - 18	KOBRA CLAMP 16,5 - 18	4	
8	X02.482.000	RACCORDO DRITTO P.G.D.13 M. 1/2"	HOSETAIL MALE THREADED 1/2"	2	
9	XFG.018.000	FASCETTA GOMMATA PER TUBI D.18	STICKER	3	
10	XRP.006.000	RONDELLA PIANA D. 6	WASHER D.6	3	
11	XTE.006.016T	VITE TE M6X16	SCREW TE M6X16	3	
12	X20.498.002	ANTIVORTICE IN ACCIAIO INOX	STAINLESS STEEL ANTI-VORTEX	1	
13	X20.436.000	GUARNIZIONE SPECIALE PER ANTIVORTICE	SPECIAL GARNISHING FOR ANTIWHIRL	1	
14	XRP.010.030	RONDELLA PIANA D.10 x 30 mm	WASHER D.10 x 30 mm	1	
15	XOR.006.162	OR D.40,65 x 5,34	O-RING GASKET 40,65 x 5,34	1	
16	X00.345.010	NIPPLO 1" 1/4 + 1" 1/4 GAS	NIPPLE 1" 1/4 + 1" 1/4 GAS	1	
17	X02.478.000	SFERA ROSSA D.8,5 PER LIVELLO	RED FLOATING BALL D.8,5	2	
18	XTAS.04,2.025I	VITE AUTOFILETTANTE 4,2 x 25	SELFTHREADED SCREW 4,2 x 25	16	
19	XDOT.10.5587	DADO OTTONE M10	M10 BRASS NUT	1	
20	X02.405.000	COPERCHIO RIBALTABILE	HINGED TANK LID	1	
21	X00.345.000	NIPPLO 1" 1/4 + 1" 1/4 GAS	NIPPLE 1" 1/4 + 1" 1/4 GAS	2	
22	X02.033.000	GUARNIZIONE PER BOCCHETTONE ASPIRAZIONE	GASKET	2	
23	X00.543.000	GHIERA 1" 1/4 GAS	NUT 1" 1/4 GAS	3	
24	X00.130.000	PRESA ANTIVORTICE 1"1/4 GAS	1"1/4 VORTIX DAMPER DRIVE	1	
25	X02.378.090	TUBETTO VITREO D. 12x16 L= 900	HOSE VITREO D. 12x16 L= 900	1	
26	X02.378.180	TUBETTO VITREO D. 12x16 L= 1800	HOSE VITREO D. 12x16 L= 1800	1	

X02.405.000

N°	Doc. Number	Titolo	Title	Q.tà	Note
1	X02.405.000.B	ANELLO BASE	BASE RING	1	
2	X02.405.001	BRACCIO	ARM	1	
3	X02.405.000.A	DISCO DI CHIUSURA	GRIPPING PLATE	1	
4	X02.405.002	GUARNIZIONE SAGOMATA	SHAPED GASKET	1	
5	X20.787.000.G	CORPO VALVOLA DI SFIATO	BREATHER VALVE	1	
6	X20.787.000.F	SFERA GALLEGGIANTE	FLOATING BALL	1	
7	X20.787.000.H	GHIERA	RING NUT	1	
8	X20.787.000.I	TAPPO PER VALVOLA DI SFIATO	CAP FOR BREATHER VALVE	1	
9	XOR.000.512	OR D.51 x 3,5	51 x 3,5 O-RING GASKET	1	
10	X20.787.000.D	PERNO	PIN	1	

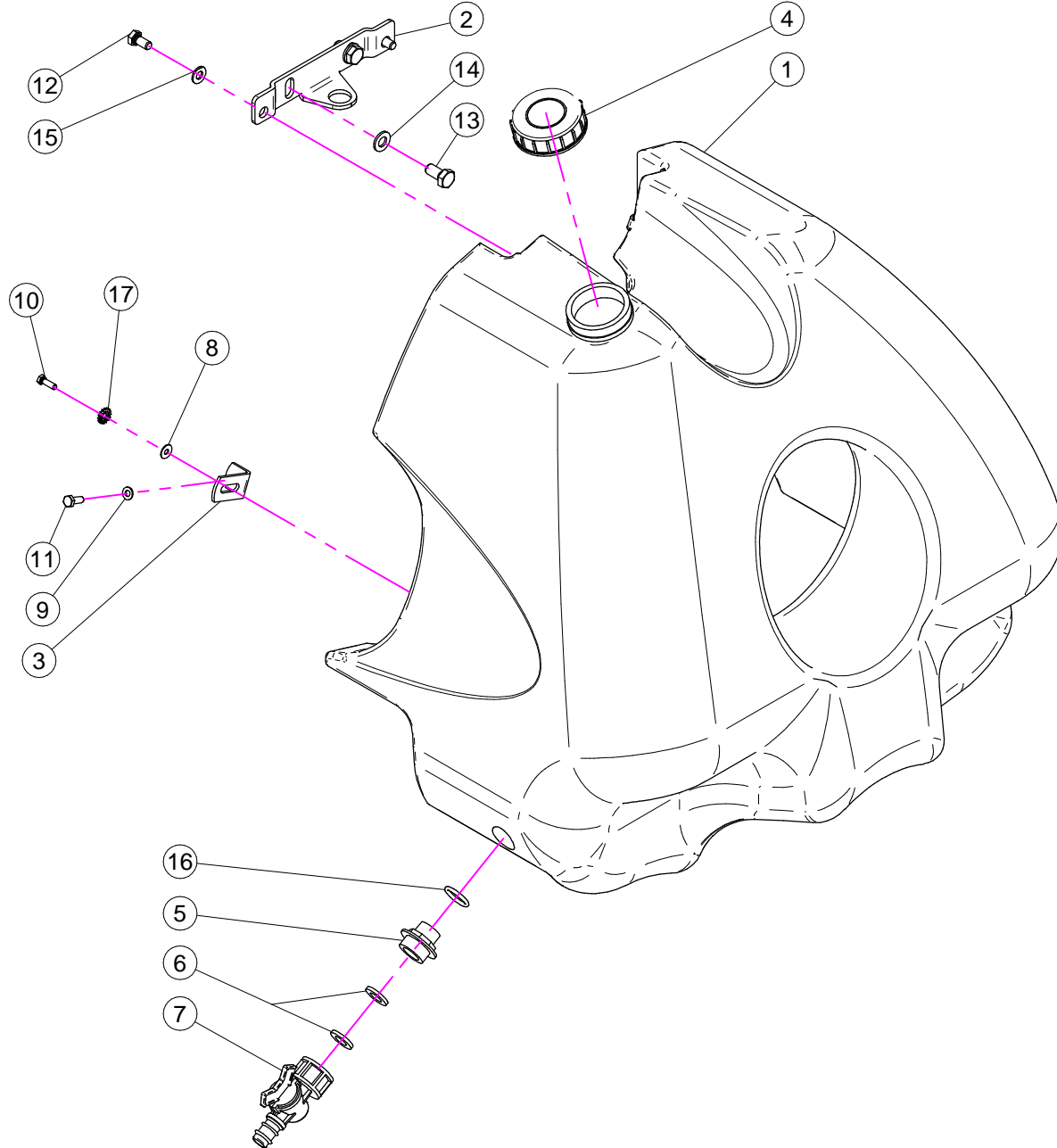
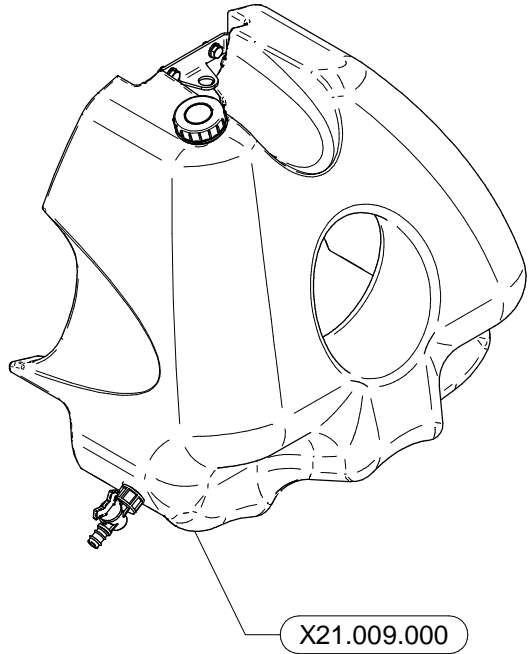

N°	Doc. Number	Titolo	Title	Q.tà	Note
1	X40.322.000	SERBATOIO LAVAMANI 30 Lt.	HAND-WASHING TANK 30 Lt.	1	
2	X40.323.000	STAFFA FISSAGGIO SERBATOIO LAVAMANI	FIXING BRACKET	1	
3	X40.324.100	PIASTRA SERBATOIO LAVAMANI SERIE 50	BRACKET	2	
4	X02.460.000	COPERCHIO FILETTATO FEMMINA	FEMALE THREADED TANK LID	1	
5	X00.055.044	NIPPLO 1/2" GAS 3/4" GAS	NIPPLE 1/2" - 3/4" GAS	1	
6	X02.030.010	GUARNIZIONE TAPPO DISTRIBUTORE	GASKET	2	
7	X02.497.000	RUBINETTO FEMMINA 3/4"	3/4" FEMALE VALVE	1	
8	XRP.005.015I	RONDELLA PIANA D. 5x15	WASHER D. 5x15	2	
9	XRP.006.000	RONDELLA PIANA D. 6	WASHER D.6	2	
10	XTE.005.016I	VITE TE M5X16	SCREW TE M5X16	2	
11	XTE.006.016T	VITE TE M6X16	SCREW TE M6X16	2	
12	XTE.008.016T	VITE TE M8x16	SCREW TE M8x16	2	
13	XTE.010.020T	VITE TE M10 x 20	SCREW TE M10 x 20	2	
14	XRP.010.000	RONDELLA PIANA D.10	WASHER D.10	2	
15	XRP.008.000	RONDELLA PIANA D.8	WASHER D.8	2	
16	XOR.004.081	OR D.20,22 x 3,53	20,22 x 3,53 O-RING GASKET	1	
17	XRD.006.000	RONDELLA DENTELLATA D.6	TAB WASHER D.6	2	

N°	Doc. Number	Titolo	Title	Q.tà	Note
1	X40.305.000	SERBATOIO LAVAIMPIANTI It 100	RESERVOIR TANK LT. 100	1	
2	X40.310.000	PROTEZIONE LAVAIMPIANTI	RESERVOIR KIT PROTECTION	1	
3	XTE.010.025T	VITE TE 10x25T	SCREW TE 10x25T	6	
4	XRP.010.000	RONDELLA PIANA D.10	WASHER D.10	12	
5	XD0.10.5587G	DADO M10	NUT M10	6	
6	X20.933.000	GUARNIZIONE SFIATO SERBATOIO	TANK BREATHER GASKET	1	
7	X02.217.060	TUBETTO DI SFIATO D.8 L=600	BREATHER PIPE D.8 L=600	1	
8	X02.460.000	COPERCHIO FILETTATO FEMMINA	FEMALE THREADED TANK LID	1	
9	X02.293.000	RIDUZIONE 1" M - 3/4" M	1" M - 3/4" M REDUCER NIPPLE	1	
10	X00.055.037	RACCORDO CURVO P.G. D.25	D.25 HOSETAIL	1	
11	X00.055.24.2	GIRELLO 1" GAS	1" FLY NUT	1	
12	XOR.000.132	OR D.23,81 x 2,62	23,81 x 2,62 O-RING GASKET	1	
13	XF0.023.035I	FASCETTA A VITE 23/35 W4 INOX	STAINLESS STEEL CLIP	2	
14	X20.934.000	PORTAGOMMA D.8	STRAIGHT HOSE D.8	1	
15	X20.954.000	SUPPORTO AD " L" SOSTEGNO SERBATOIO	TANK BRACKET	1	
16	XTE.010.020T	VITE TE M10 x 20	SCREW TE M10 x 20	2	
17	X20.809.100	TUBO D. 25 L= 1000	HOSE D. 25 L= 1000	1	

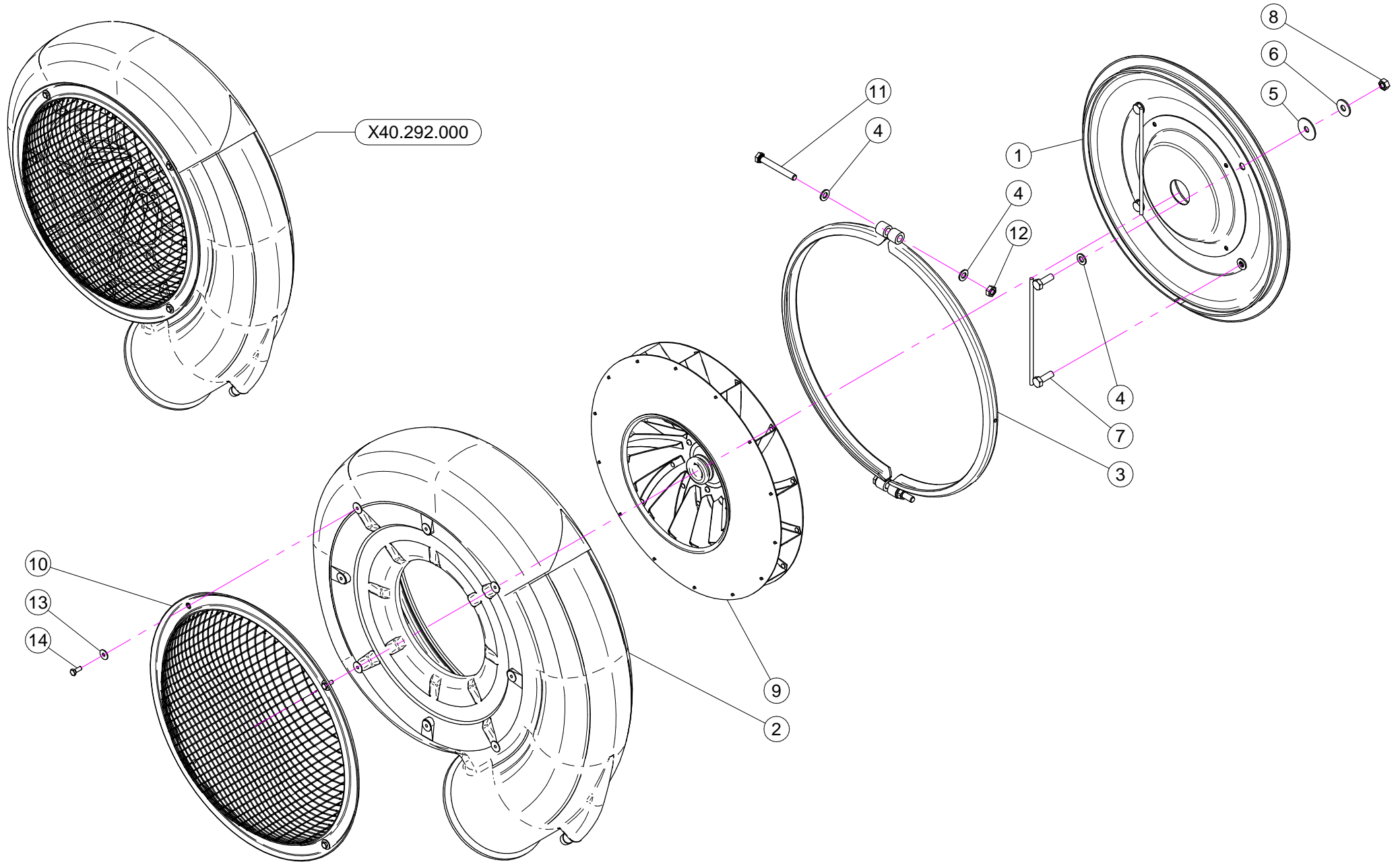

N°	Doc. Number	Titolo	Title	Q.tà	Note
1	X40.268.000	COPERCHIO VENTOLA 45	FAN 45 COVER	1	
2	X04.854.000	CARTER VENTOLA P/T45N	FAN CASING P/T45N	1	
3	X04.874.000.Z	COLLARE D.485 ZINCATO	D.485 CLAMP	1	
4	XRP.010.000	RONDELLA PIANA D.10	WASHER D.10	8	
5	XRP.010.040	RONDELLA PIANA D.10 X 40	WASHER D.10 X 40	4	
6	XRP.010.030	RONDELLA PIANA D.10 x 30 mm	WASHER D.10 x 30 mm	4	
7	X20.088.000	CAVALLOTTO POSTERIORE CARTER VENTOLA	BACK COVER BRACKET	2	
8	XD0.10.5587G	DADO M10	NUT M10	4	
9	X04.720.000	VENTOLA D.450 X P/T/LP/TP45	FAN 450	1	
10	X05.654.200	RETE PROTEZIONE VENTILATORE	FAN NET PROTECTION	1	
11	XTE.010.080T	VITE M10x80	M10x80 BOLT	2	
12	XDOT.10.5587	DADO OTTONE M10	M10 BRASS NUT	2	
13	XRP.006.018	RONDELLA PIANA D. 6x18	WASHER D.6x18	4	
14	XTE.006.016T	VITE TE M6X16	SCREW TE M6X16	4	

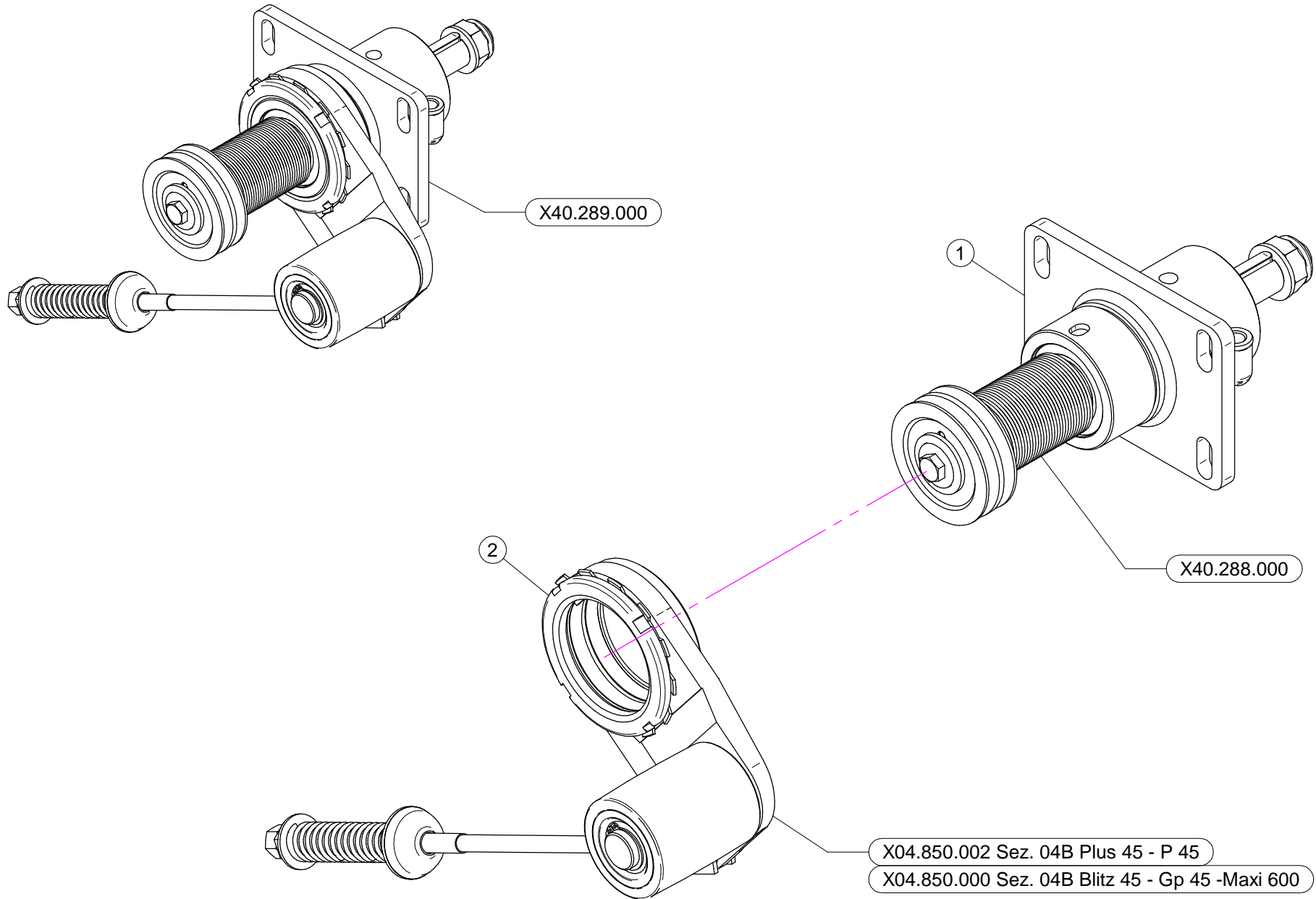

N°	Doc. Number	Titolo	Title	Q.tà	Note
1	X40.288.000	SUPPORTO OLIO 45 - PUL. D.54 SENZA DISINNESTO	FAN SUPPORT - PUL D.54 NO DISENGAGEMENT	1	
2	X04.850.000	TENDICINGHIA AUTOMATICO COMPLETO	AUTOMATIC BELT STRETCHER	1	

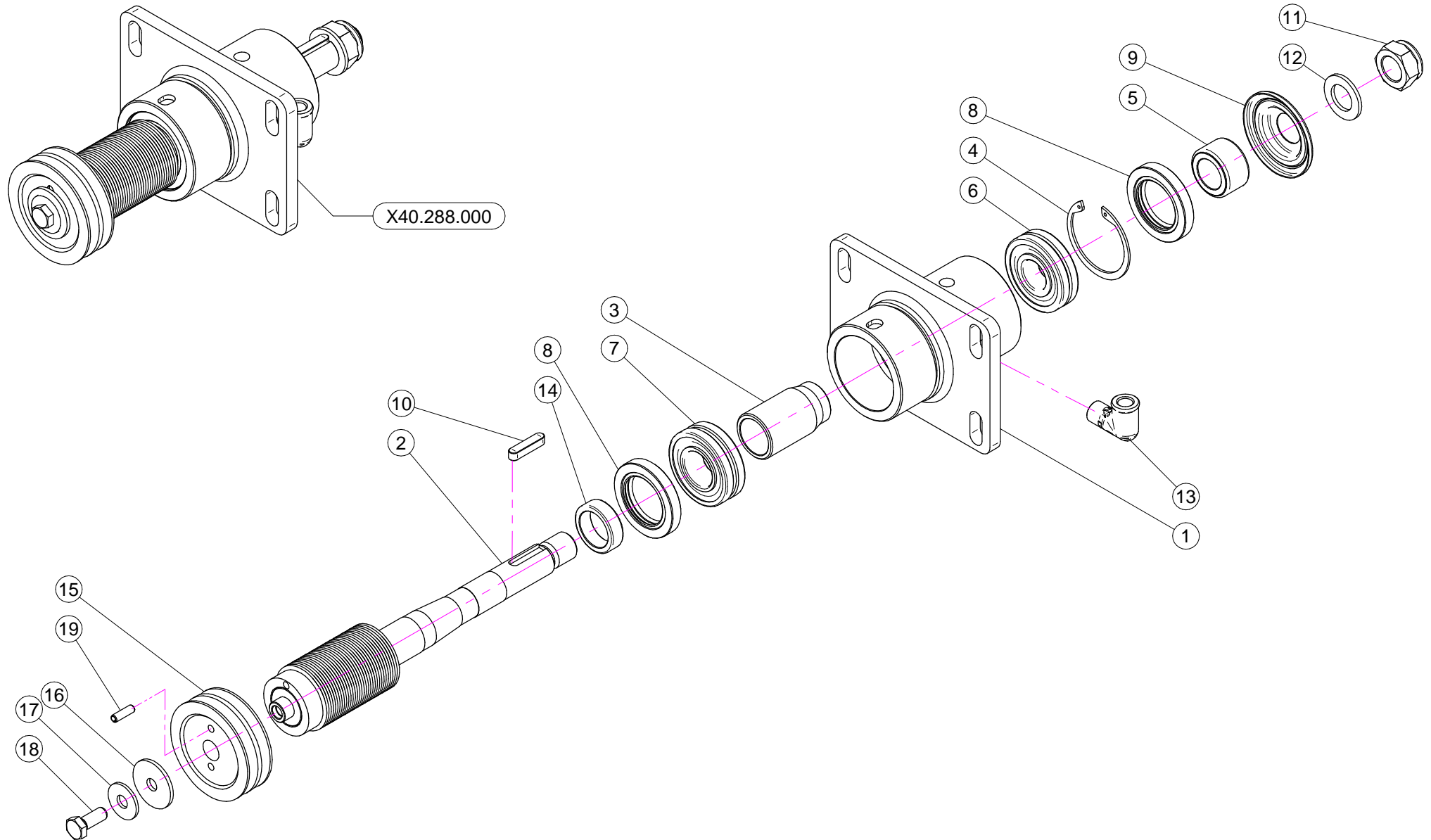

N°	Doc. Number	Titolo	Title	Q.tà	Note
1	X40.260.000	SUPPORTO VENTILATORE NUDO	FAN SUPPORT	1	
2	X40.271.054	ALBERO CON PULEGGIA D. 54 J32	SHAFT WITH PULLEY D.54 J32	1	
3	X40.262.000	DISTANZIALE SUPPORTO VENTILATORE	SPACER FAN SUPPORT	1	
4	XI0.062.000	ANELLO ELASTICO INTERNO D. 62	INTERNAL D. 62 CIRCLIP	1	
5	X40.263.000	DISTANZIALE TENUTA LATO VENTOLA	SIDE FAN SEAL SPACER	1	
6	XK0.021.305	CUSCINETTO A RULLI OBLIQUI 21.305	BEARING TO OBLIQUE SEAMS 21.305	1	
7	XK0.022.206	CUSCINETTO A RULLI OBLIQUI 22.206	BEARING TO OBLIQUE SEAMS 22.206	1	
8	XBASL.40.62.10	ANELLO DI TENUTA IN VITON 40.62.10	VITON LIP SEALS IEL 40.62.10	2	
9	X40.267.000	COPERCHIETTO LATO VENTOLA	SIDE FAN COVER	1	
10	XL.08.07.35	LINGUETTA 8x7x35	8x7x35 TANG	1	
11	XDA.022.0BF	DADO ESAGONALE M22 AUTOBLOCCANTE	SELF-LOCKING NUT M22 x 1,5	1	
12	XRP.022.000	RONDELLA PIANA D.22	WASHER D.22	1	
13	X20.789.000	GOMITO 90° TUBO DI CARICO OLIO	MALE/FEMALE 90° ELBOW	1	
14	X40.264.000	DISTANZIALE PER TENUTA LATO PULEGGIA	SPACER	1	
15	X05.746.000	PULEGGIA COMANDO POMPA D.82 2x3V	PULLEY FOR PUMP D.82 2x3V	1	
16	XRP.010.040	RONDELLA PIANA D.10 X 40	WASHER D.10 X 40	1	
17	XRP.010.030	RONDELLA PIANA D.10 x 30 mm	WASHER D.10 x 30 mm	1	
18	XTE.010.025FT	VITE TE M10x25	BOLT TE M10x25	1	
19	XSE.006.020	SPINA ELASTICA D.6x20	SPRING PIN D.6x20	1	

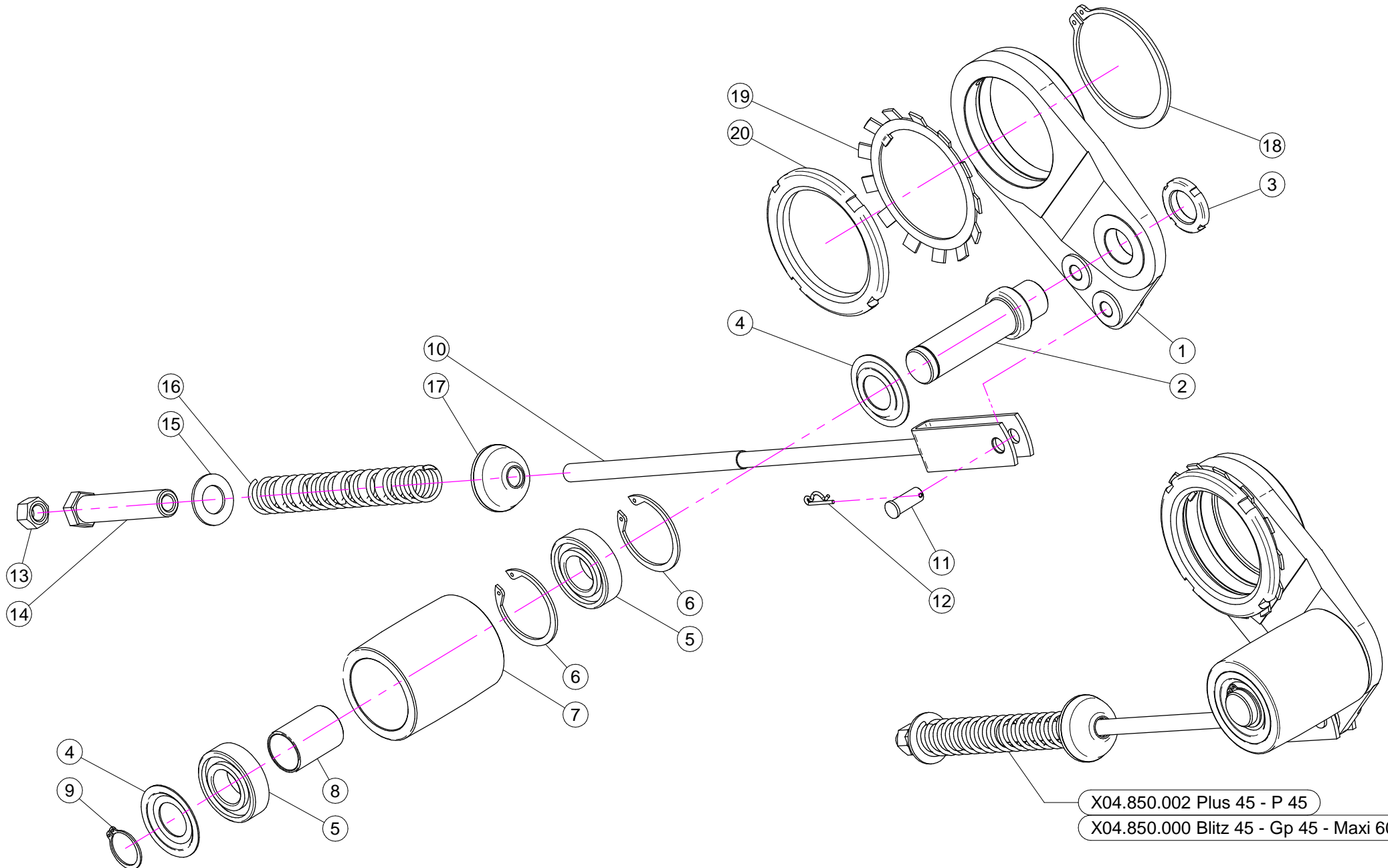

X04.850.002 PLUS 45 - P 45

N°	Doc. Number	Titolo	Title	Q.tà	Note
1	X04.095.000	SUPPORTO PER TENDICINGHIA AUTOMATICO	BELT STRETCHER HOUSING	1	
2	X04.835.000	PERNO PER TENDICINGHIA AUTOMATICO	BELT STRETCHER PIN	1	
3	XKM.005.000	GHIERA KM5	NUT KM5	1	
4	X04.585.000	COPERCHIO PARAPOLVERE TENDICINGHIA	ANTI - DUST COVER	2	
5	XK6.205.2RS	CUSCINETTO 6205-2RS	ROLLER BEARING 6205-2RS	2	
6	XI0.052.000	ANELLO ELASTICO INTERNO D. 52	INTERNAL D. 52 CIRCLIP	2	
7	X04.083.000	RULLO TENDICINGHIA AUTOMATICO	ROLLER FOR BELT STRETCHER	1	
8	X04.084.000	DISTANZIALE PER TENDICINGHIA AUTOMATICO	SPACER FOR BELT STRETCHER	1	
9	XE0.025.000	ANELLO ELASTICO ESTERNO D. 25	EXTERNAL D. 25 CIRCLIP	1	
10	X05.653.000	FORCELLA TENSIONE TENDICINGHIA	BELT TRETCHER FORK	1	*
11	X04.593.000	PERNO FORCELLA TENDICINGHIA	PIN	1	
12	X00.100.002	COPIGLIA	CLIP	1	
13	XD0.12.5587G	DADO M12 PG UNI 5587	M12 NUT	1	
14	X04.583.000	VITE SPECIALE MOLLA TENDICINGHIA	SPECIAL SCREW	1	
15	XRP.019.000	RONDELLA PIANA D.19 6592	WASHER D.19	1	
16	X04.093.100	MOLLA TENDICINGHIA AUTOMATICO	SPRING	1	
17	X20.260.000	RONDELLA BOMBATA D.12 PER TENDICINGHIA	SPECIAL WASHER D.12	1	
18	XE0.080.000	ANELLO ELASTICO ESTERNO D.80	EXTERNAL D 80 CIRCLIP	1	
19	XMB.016.000	ROSETTA DI SICUREZZA MB 16	TOOTH LOCK WASHER MB 16	1	
20	X04.099.000	GHIERA DI REGISTRO M 80x2	NUT M 80x2	1	

X04.850.000 BLITZ 45 - GP 45 - MAXI 600

N°	Doc. Number	Titolo	Title	Q.tà	Note
1	X04.095.000	SUPPORTO PER TENDICINGHIA AUTOMATICO	BELT STRETCHER HOUSING	1	
2	X04.835.000	PERNO PER TENDICINGHIA AUTOMATICO	BELT STRETCHER PIN	1	
3	XKM.005.000	GHIERA KM5	NUT KM5	1	
4	X04.585.000	COPERCHIO PARAPOLVERE TENDICINGHIA	ANTI - DUST COVER	2	
5	XK6.205.2RS	CUSCINETTO 6205-2RS	ROLLER BEARING 6205-2RS	2	
6	XI0.052.000	ANELLO ELASTICO INTERNO D. 52	INTERNAL D. 52 CIRCLIP	2	
7	X04.083.000	RULLO TENDICINGHIA AUTOMATICO	ROLLER FOR BELT STRETCHER	1	
8	X04.084.000	DISTANZIALE PER TENDICINGHIA AUTOMATICO	SPACER FOR BELT STRETCHER	1	
9	XE0.025.000	ANELLO ELASTICO ESTERNO D. 25	EXTERNAL D. 25 CIRCLIP	1	
10	X05.653.100	FORCELLA TENSIONE TENDICINGHIA	BELT TRETCHER FORK	1	*
11	X04.593.000	PERNO FORCELLA TENDICINGHIA	PIN	1	
12	X00.100.002	COPIGLIA	CLIP	1	
13	XD0.12.5587G	DADO M12 PG UNI 5587	M12 NUT	1	
14	X04.583.000	VITE SPECIALE MOLLA TENDICINGHIA	SPECIAL SCREW	1	
15	XRP.019.000	RONDELLA PIANA D.19 6592	WASHER D.19	1	
16	X04.093.100	MOLLA TENDICINGHIA AUTOMATICO	SPRING	1	
17	X20.260.000	RONDELLA BOMBATA D.12 PER TENDICINGHIA	SPECIAL WASHER D.12	1	
18	XE0.080.000	ANELLO ELASTICO ESTERNO D.80	EXTERNAL D 80 CIRCLIP	1	
19	XMB.016.000	ROSETTA DI SICUREZZA MB 16	TOOTH LOCK WASHER MB 16	1	
20	X04.099.000	GHIERA DI REGISTRO M 80x2	NUT M 80x2	1	

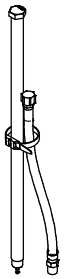

K.LUBR.50.P01

Plus 42-45-50-55 - Blitz "A" 50-55

Link 50-55 - Gp 50-55

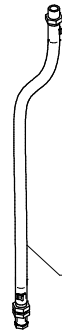
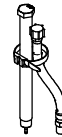
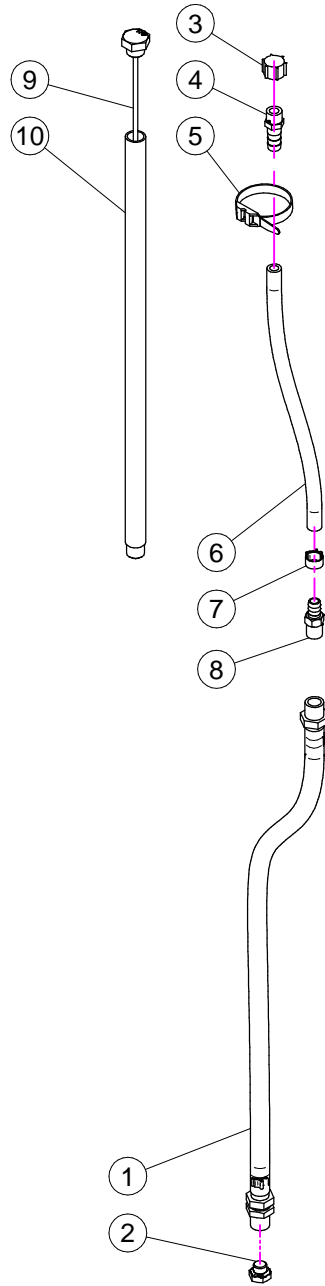

K.LUBR.50.T01

Blitz 45-50-55 - Maxi 600

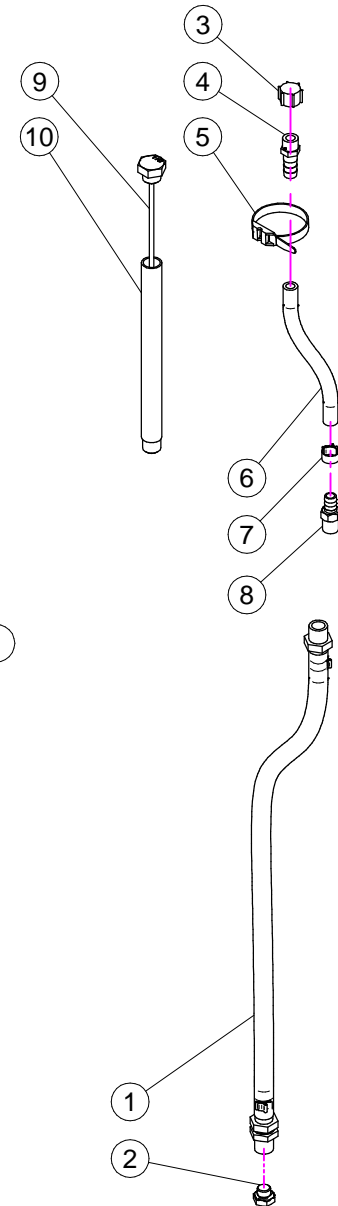

K.LUBR.50.P01 (Plus 42-45-50-55 - Blitz "A" 50-55 - Link 50-55 - Gp 50-55)

N°	Doc. Number	Titolo	Title	Q.tà	Note
1	X20.790.000	TUBO DI SCARICO OLIO 3/8" CIL. - 3/8" CON.	DRAIN PIPE 3/8"	1	
2	X40.266.000	TAPPO SCARICO OLIO M12x1,5	OIL EXHAUSTPLUG	1	
3	X02.013.000	TAPPO CIMA G 1/4" F.	PLUG G 1/4"	1	
4	X00.414.100	PORTAGOMMA D.11 1/4" M. FORATO	STRAIGHT HOSE D.11 1/4" WITH BLEED	1	
5	X02.355.000	FASCETTA D'ASSEMBLAGGIO 235 mm	NYLON ASSEMBLY CLAMP	1	
6	X02.217.025	TUBO D. 8x13 L= 250	HOSE D. 8x13 L= 250	1	
7	XFC.014.5.016	FASCETTA COBRA SLO30716	KOBRA CLAMP	1	
8	X20.792.000	PORTAGOMMA D.11 G 1/4" M. PER SFIATO	STRAIGHT HOSE D.11 G 1/4" FOR BREATHER	1	
9	X50.116.000	TAPPO CON ASTA LIVELLO OLIO L=465	FILLING PLUG WITH DIPSTICK	1	
10	X50.122.000	TUBO DI CARICO OLIO L=451	FILLING PIPE L=451	1	

K.LUBR.50.T01 (Blitz 45-50-55 - Maxi 600)

N°	Doc. Number	Titolo	Title	Q.tà	Note
1	X20.790.000	TUBO DI SCARICO OLIO 3/8" CIL. - 3/8" CON.	DRAIN PIPE 3/8"	1	
2	X40.266.000	TAPPO SCARICO OLIO M12x1,5	OIL EXHAUSTPLUG	1	
3	X02.013.000	TAPPO CIMA G 1/4" F.	PLUG G 1/4"	1	
4	X00.414.100	PORTAGOMMA D.11 1/4" M. FORATO	STRAIGHT HOSE D.11 1/4" WITH BLEED	1	
5	X02.355.000	FASCETTA D'ASSEMBLAGGIO 235 mm	NYLON ASSEMBLY CLAMP	1	
6	X02.217.015	TUBO D. 8x13 L= 150	HOSE D. 8x13 L= 150	1	
7	XFC.014.5.016	FASCETTA COBRA SLO30716	KOBRA CLAMP	1	
8	X20.792.000	PORTAGOMMA D.11 G 1/4" M. PER SFIATO	STRAIGHT HOSE D.11 G 1/4" FOR BREATHER	1	
9	X40.269.000	TAPPO CON ASTA LIVELLO L=215	FILLIG PLUG WITH DIPSTICK L=215	1	
10	X40.272.000	TUBO CARICAMENTO L=201	FILLING PIPE L=201	1	

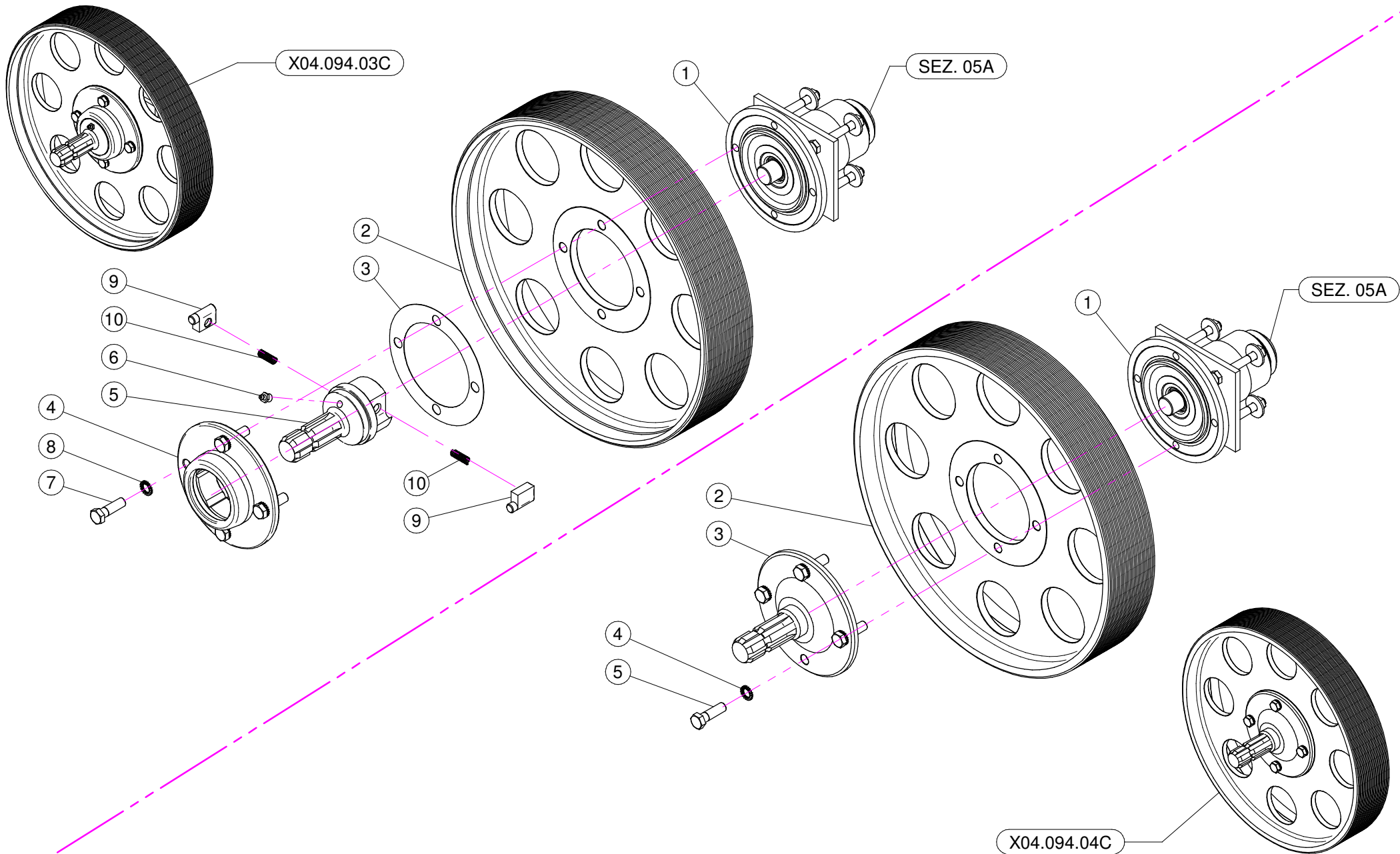

X04.094.03C

N°	Doc. Number	Titolo	Title	Q.tà	Note
1	X04.094.01C	SUPPORTO INFERIORE P40 - P/T45 - LP/TP45	CLUTCH	1	
2	X00.450.J32	PULEGGIA DI COMANDO 450J32	PULLEY	1	
3	X04.719.000	GUARNIZIONE RUOTA LIBERA	GASKET	1	
4	X04.066.000	CORPO ESTERNO RUOTA LIBERA	BODY	1	
5	X03.701.000	ROTORE RUOTA LIBERA	ROTOR	1	
6	XID.010.001	INGRASSATORE DIRITTO M10X1	GREASE NIPPLE	1	
7	XTE.012.040F	VITE M12X40	BOLT M12X40	4	
8	XRD.012.000	RONDELLA DENTELLATA D.12	TAB WASHER D.12	4	
9	X02.502.002	MARTELLETTO RUOTA LIBERA	PIN	2	
10	X02.502.001	MOLLA A COMPRESSIONE	SPRING	2	

X04.094.04C

N°	Doc. Number	Titolo	Title	Q.tà	Note
1	X04.094.01C	SUPPORTO INFERIORE P40 - P/T45 - LP/TP45	CLUTCH	1	
2	X00.450.J32	PULEGGIA DI COMANDO 450J32	PULLEY	1	
3	X04.707.100	ALBERO SCANALATO PER P.D.P.	SHAFT	1	
4	XRD.012.000	RONDELLA DENTELLATA D.12	TAB WASHER D.12	4	
5	XTE.012.040F	VITE M12X40	BOLT M12X40	4	

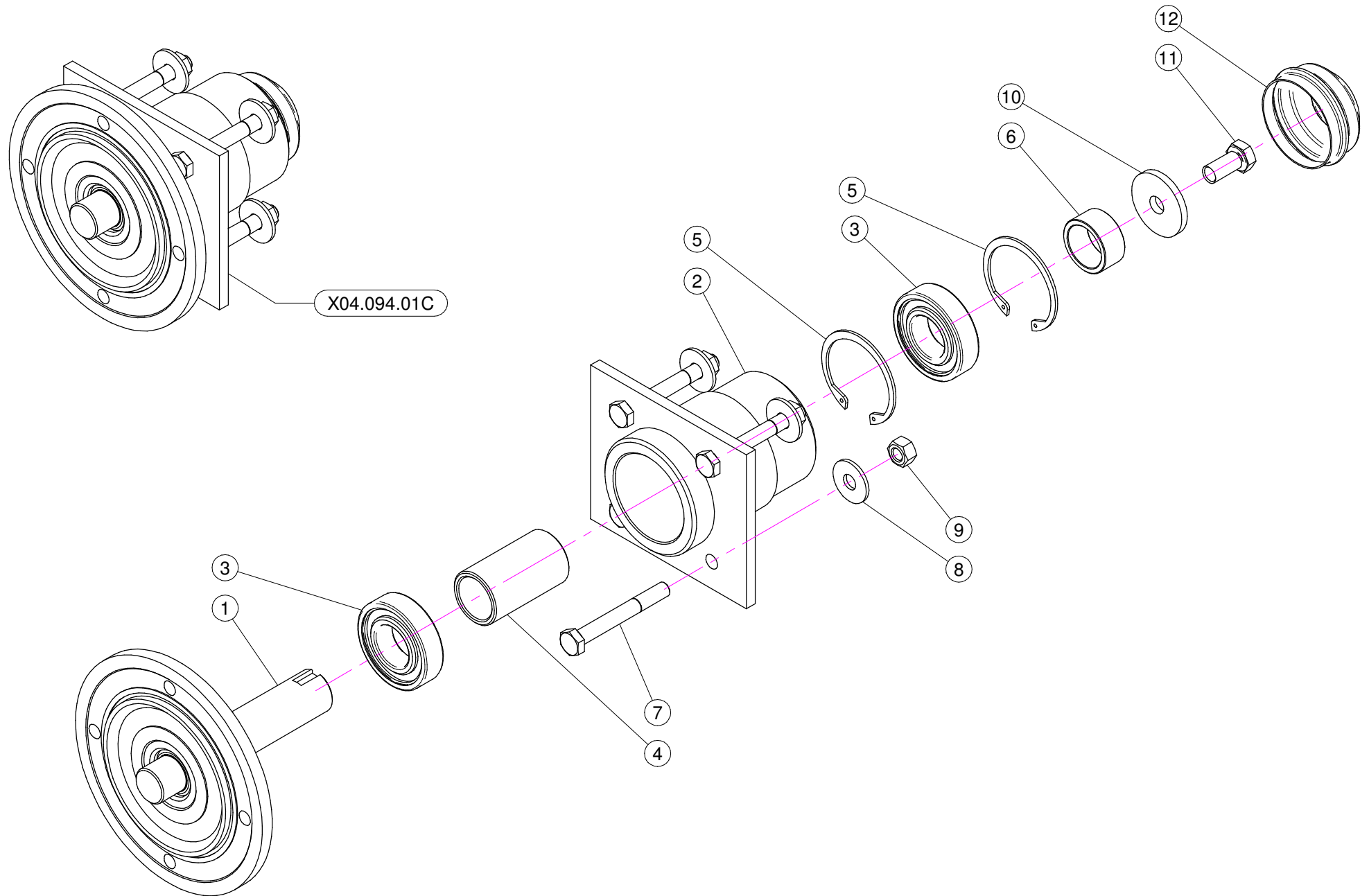

N°	Doc. Number	Titolo	Title	Q.tà	Note
1	X04.085.000	ALBERO INFERIORE	SHAFT	1	
2	X04.094.000	SUPPORTO INFERIORE	CLUTCH	1	
3	XK6.206.2RS	CUSCINETTO	BEARING	2	
4	X04.060.000	DISTANZIALE PER ALBERO INFERIORE	SPACER	1	
5	XI0.062.000	ANELLO ELASTICO INTERNO D. 62	INTERNAL D. 62 CIRCLIP	2	
6	X04.590.000	DISTANZIALE PER ALBERO INFERIORE	SPACER	1	
7	XTE.010.080	VITE TE M10 x 80	SCREW TE M10 x 80	4	
8	XRP.010.030	RONDELLA PIANA D.10 x 30 mm	WASHER D.10 x 30 mm	4	
9	XD0.10.5587G	DADO M10	NUT M10	4	
10	X20.810.000	RONDELLA SPECIALE PER SUPPORTO INFERIORE	SPECIAL WASHER FOR LOWER SUPPORT	1	
11	XTE.012.025FT	VITE TE 12X25	BOLT TE M12X1.25	1	
12	X04.062.001	COPERCHIETTO DI CHIUSURA	COVER	1	

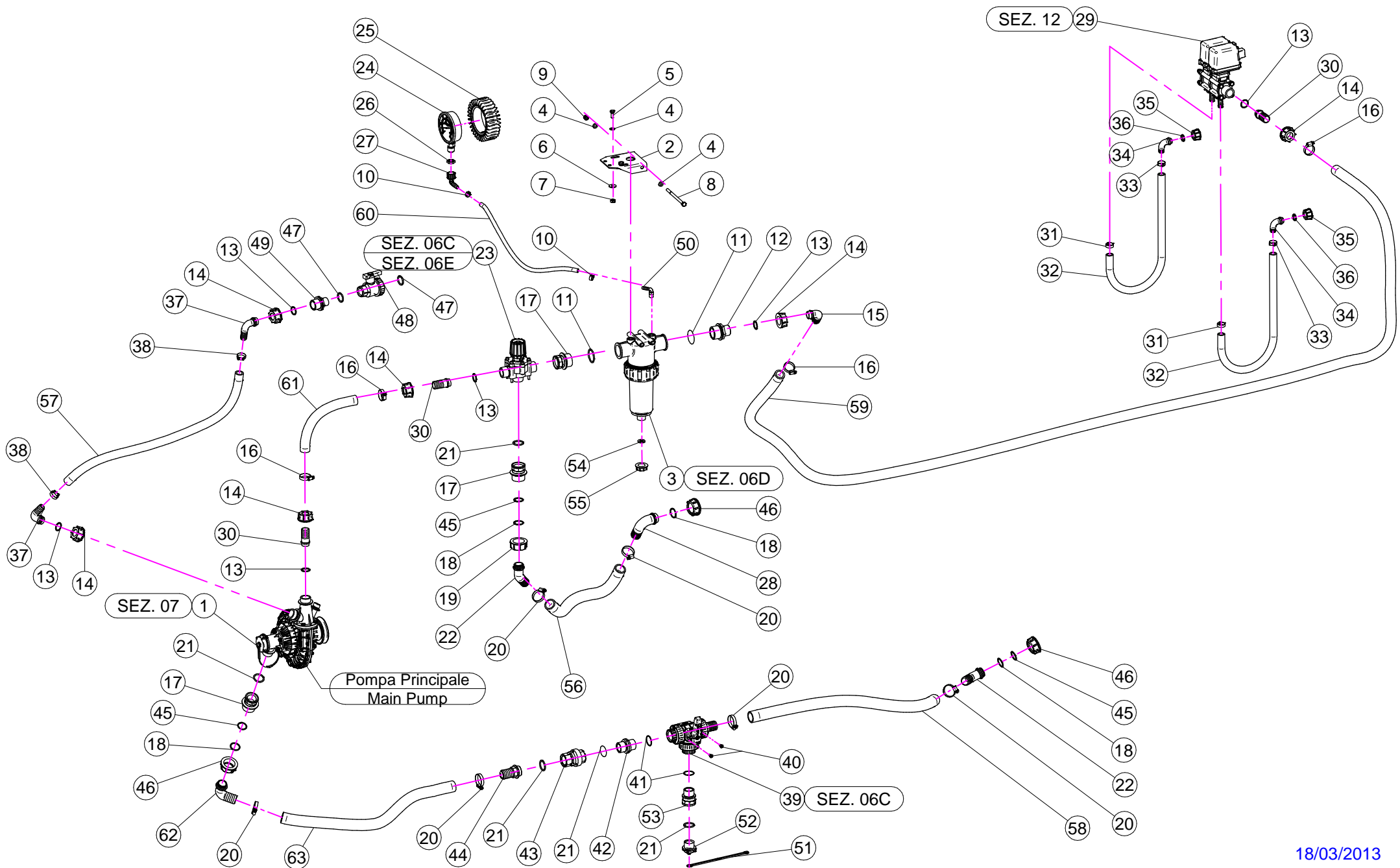

N°	Doc. Number	Titolo	Title	Q.tà	Note
1	X02.157.071	POMPA COMPLETA	PUMP	1	
2	X20.519.100	STAFFA FISSAGGIO GRUPPO REGOLAZIONE	BRACKET	1	
3	X02.450.110	FILTRO IN LINEA F. 1" 1/4	LINE FILTER 1" 1/4 FEMALE	1	
4	XRP.008.000	RONDELLA PIANA D.8	WASHER D.8	4	
5	XTE.008.025T	VITE TE 8X25	SCREW TE M8X25	2	
6	XRP.008.024	RONDELLA PIANA LARGA D.8X24	WASHER D.8X24	2	
7	XD0.08.5588G	DADO M8 6S PG	M8 6S BIG LEAD NUT 5588	2	
8	XTE.008.130	VITE TE M8 x 130	SCREW M8 x 130	1	
9	XDA.008.0AG	DADO AUTOBLOCCANTE M8	SELF LOCKING NUT M8	1	
10	XFC.013.5.015	FASCETTA COBRA SLO30710	KOBRA CLAMP	2	
11	XOR.000.144	OR D.39,69x3,53	O-RING D.39,69x3,53	2	
12	X00.045.012	RIDUZIONE 1" 1/4 M - 1" M	1" 1/4 M - 1" M REDUCER NIPPLE	1	
13	XOR.000.132	OR D.23,81 x 2,62	23,81 x 2,62 O-RING GASKET	6	
14	X00.055.24.2	GIRELLO 1" GAS	1" FLY NUT	6	
15	X00.055.037	RACCORDO CURVO P.G. D.25	D.25 HOSETAIL	1	
16	XF0.023.035I	FASCETTA A VITE 23/35 W4 INOX	STAINLESS STEEL CLIP	4	
17	X02.374.000	RIDUZIONE M/F 1"F / 1"1/4M	M. / F. 1"F / 1"1/4M REDUCTION	3	
18	XOR.003.112	OR D.28,24x2,62	O-RING D.28,24x2,62	4	
19	X00.058.006	GIRELLO 1" 1/4 GAS	1" 1/4 FLY NUT	1	
20	XF0.025.040I	FASCETTA A VITE 25/40 W4 INOX	STAINLESS STEEL CLIP	6	
21	XOR.004.118	OR D.29,75 x 3,53	29,75 x 3,53 O-RING GASKET	5	
22	X02.339.000	RACCORDO CURVO A 45° CON P.G. D.30	45° HOSETAIL	2	
23	X02.447.000	VALVOLA A 3 VIE	3 WAY VALVE	1	
24	X02.445.000	MANOMETRO D.100 INOX 0-6 BAR	PRESSURE GAUGE Ø100 INOX 0-6 BAR	1	
25	X02.470.000	CUFFIA PER MANOMETRO D.100	PRESSURE GAUGE GUARD	1	
26	X24.072.000	GHIERA IN OTTONE 1/2"	BRASS FLY NUT 1/2"	1	
27	X21.012.000	RACCORDO CURVO PG D. 12 G. 1/2"	D. 12 HOSETAIL	1	
28	X00.058.004	RACCORDO CURVO P.G. D.30	D.30 HOSETAIL	1	
29	X02.390.08C	ELETTROVALVOLE	ELECTROVALVES	1	
30	X00.055.021	RACCORDO DIRITTO PG D.25	STRAIGHT HOSE R.H D.25	3	
31	XFC.021.5.023	FASCETTA COBRA 21,5 - 23	KOBRA CLAMP 21,5 - 23	2	
32	X02.211.110	TUBO D.16 L=1100	HOSE D.16 L=1100	2	

N°	Doc. Number	Titolo	Title	Q.tà	Note
33	XFC.023.5.025	FASCETTA COBRA 23,5 - 25	KOBRA CLAMP 23,5 - 25	2	
34	X00.055.046	RACCORDO CURVO P.G. D.17	CURVED UNION WITH R.H. D.17	2	
35	X00.055.045	GIRELLO 3/4" GAS	3/4" FLY NUT	2	
36	X02.349.000	GUARNIZIONE PIANA D.17X23X3	17X23X3 FLAT GASKET	2	
37	X00.055.038	RACCORDO CURVO A P.G. D.19	CURVED UNION WITH R.H. D.19	2	
38	XFC.026.5.028	FASCETTA COBRA 26,5 - 28	KOBRA CLAMP 26,5 - 28	2	
39	X21.058.300	VALVOLA 3 VIE A SFERA CON 1 PG D.30	THREE WAYS VALVE	1	
40	XTA.006.012P	VITI PER MAT. PLASTICI M6 x 12	SCREW M6 x 12	2	
41	XOR.002.125	OR D.31,47 x 1,78	31,47 x 1,78 O-RING GASKET	2	
42	X00.055.034	NIPPLO 1" / 1" GAS	NIPPLE 1" / 1" GAS	1	
43	X21.149.000	VALVOLA DI RITEGNO 1" F.-F.	VALVE 1" F.-F.	1	
44	X00.422.100	RACCORDO DIRITTO PG 30 FIL.1" GAS TORNITO	MALE CONNECTOR RH 30 1" GAS	1	
45	XOR.003.106	OR D.26.65x2.62	O-RING D.26.65x2.62	3	
46	X00.493.000	GIRELLO 1" 1/4 GAS	1" 1/4 FLY NUT	3	
47	XOR.000.134	OR D.25,8x3,53	O-RING D.25,8x3,53	2	
48	X02.395.000	RUBINETTO 3/4" GAS F.F. SFERA	VALVE 3/4" GAS F.F. BALL	1	
49	X02.293.000	RIDUZIONE 1" M - 3/4" M	1" M - 3/4" M REDUCER NIPPLE	1	
50	X21.084.000	RACCORDO 90° WES 8 / R1/4	HOSETAIL 90° WES 8 / R1/4	1	
51	X21.183.000	STRISCIA FERMATAPPI	CAP STOP	1	
52	X21.182.000	TAPPO 1" M	PACKING 1" M	1	
53	X02.384.000	RIDUZIONE 1" M - 1" F	1" M - 1" F REDUCER NIPPLE	1	
54	X02.030.010	GUARNIZIONE TAPPO DISTRIBUTORE	GASKET	1	
55	X02.182.000	TAPPO 3/4" FEMMINA	FEMALE 3/4" CAP	1	
56	X20.852.080	TUBO D. 30x41 L= 800	HOSE D. 30x41 L= 800	1	
57	X02.212.100	TUBO D. 19x28 L= 1000	HOSE D. 19x28 L= 1000	1	
58	X02.238.090	TUBO D. 30x38 L= 900	HOSE D. 30x38 L= 900	1	
59	X20.770.350	TUBO D. 25x32 L= 3500	HOSE D. 25x32 L= 3500	1	
60	X02.217.040	TUBO D. 8x13 L= 400	HOSE D. 8x13 L= 400	1	
61	X20.809.030	TUBO CON RAMINO D.25x32 L=300	HOSE D.25x32 L=300	1	
62	X00.483.000	RACCORDO CURVO PG 30 1-1/4"	D.30 1-1/4" HOSETAIL	1	
63	X20.852.070	TUBO CON RAMINO D.30 L=700	HOSE D.30 L=700	1	

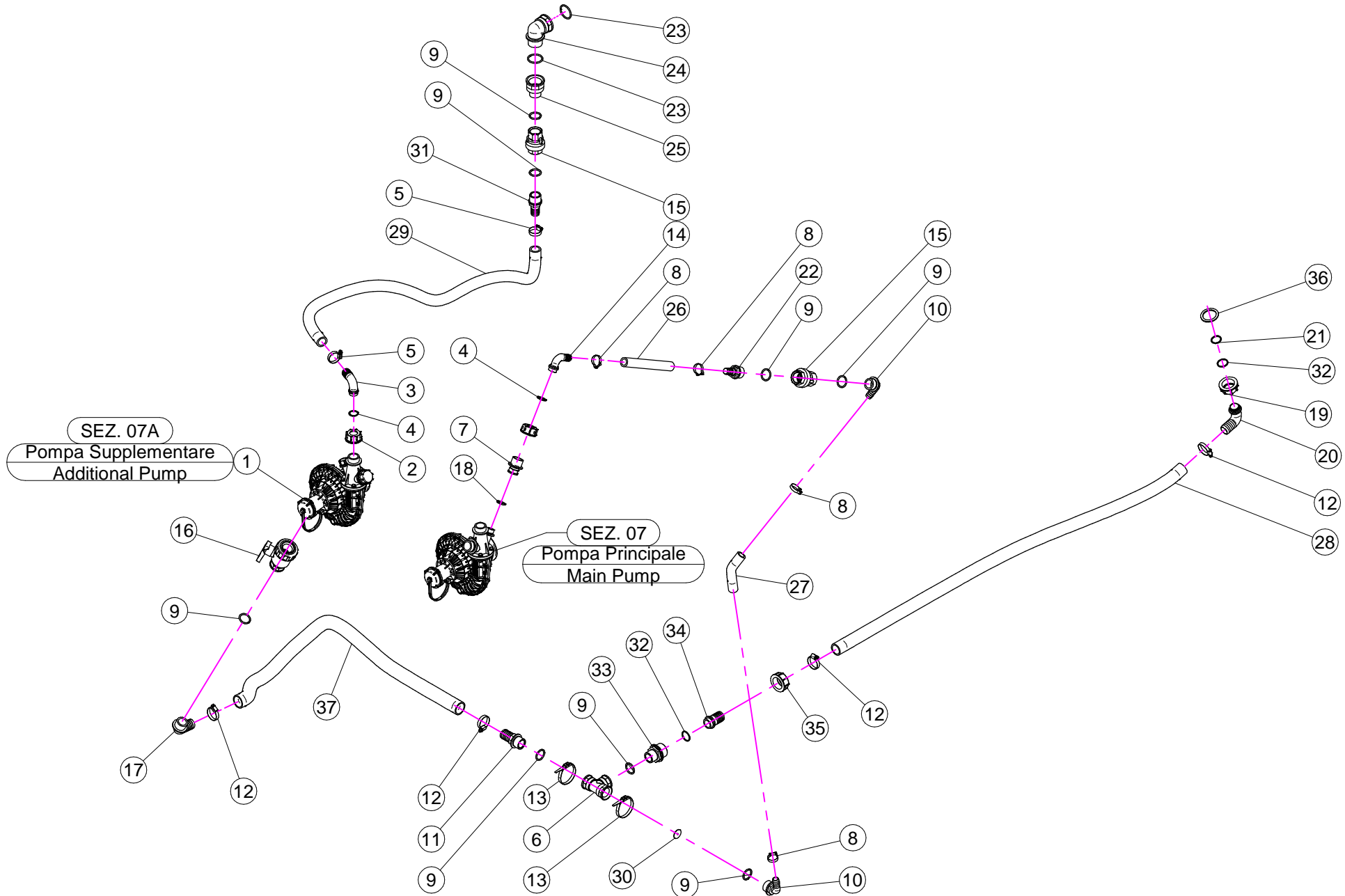

N°	Doc. Number	Titolo	Title	Q.tà	Note
1	X02.157.062	POMPA COMPLETA	PUMP	1	
2	X00.055.24.2	GIRELLO 1" GAS	1" FLY NUT	2	
3	X00.055.037	RACCORDO CURVO P.G. D.25	D.25 HOSETAIL	1	
4	XOR.000.132	OR D.23,81 x 2,62	23,81 x 2,62 O-RING GASKET	2	
5	XF0.023.035I	FASCETTA A VITE 23/35 W4 INOX	STAINLESS STEEL CLIP	2	
6	X02.274.000	RACCORDO FILETTATO A T 1" FEMMINA	FEMALE TESSE 1"	1	
7	X21.186.000	RIDUZIONE 1" M - 1/2" F	REDUCER NIPPLE 1" M - 1/2" F	1	
8	XFC.027,5.029	FASCETTA COBRA 27,08 - W8	KOBRA CLAMP 27,08 - W8	4	
9	XOR.004.118	OR D.29,75 x 3,53	29,75 x 3,53 O-RING GASKET	8	
10	X21.193.000	RACCORDO CURVO 90° 1" P.G.	HOSETAIL 90° 1" R.H.	2	
11	X00.422.000	RACCORDO DIRITTO PG 30 FIL.1" GAS	MALE CONNECTOR RH 30 1" GAS	1	
12	XF0.025.040I	FASCETTA A VITE 25/40 W4 INOX	STAINLESS STEEL CLIP	4	
13	X02.355.000	FASCETTA D'ASSEMBLAGGIO 292 mm	NYLON ASSEMBLY CLAMP	2	
14	X00.055.038	RACCORDO CURVO A P.G. D.19	CURVED UNION WITH R.H. D.19	1	
15	X21.149.000	VALVOLA DI RITEGNO 1" F.-F.	VALVE 1" F.-F.	2	
16	X04.109.000	VALVOLA A SFERA A 2 VIE	TWO WAYS VALVE	1	
17	X00.465.000	RACCORDO CURVO A P.G. D.30 1" GAS	HOSETAIL D.30 1" GAS	1	
18	XOR.004.081	OR D.20,22 x 3,53	20,22 x 3,53 O-RING GASKET	1	
19	X00.493.000	GIRELLO 1" 1/4 GAS	1" 1/4 FLY NUT	1	
20	X00.483.000	RACCORDO CURVO PG 30 1-1/4"	D.30 1-1/4" HOSETAIL	1	
21	XOR.003.106	OR D.26.65x2.62	O-RING D.26.65x2.62	1	
22	X02.402.100	RACCORDO DIRITTO PG D.19 - 1"	STRAIGHT HOSE R. H D.19 - 1"	1	
23	XOR.000.144	OR D.39,69x3,53	O-RING D.39,69x3,53	2	
24	X24.070.000	RACCORDO CURVO M-F 1"1/4	HOSETAIL 1"1/4	1	
25	X02.361.100	RIDUZIONE 1" 1/4 F - 1" M (tagliata)	REDUCER NIPPLE 1" 1/4 F - 1" M (cut)	1	
26	X02.212.017	TUBO D. 19 L= 170	HOSE D. 19 L= 170	1	
27	X02.212.017	TUBO D. 19 L= 170	HOSE D. 19 L= 170	1	
28	X20.852.160	TUBO SPIRALATO D. 30 L= 1600	HOSE D. 30 L= 1600	1	
29	X20.809.120	TUBO SPIRALATO D. 25 L= 1200	HOSE D. 25 L= 1200	1	
30	X40.386.000	RONDELLA CON FORO D.4 x RACCORDO A T 2° POMPA BLITZ E LINK	WASHER WITH HOLE D.4 x TEE-PIECE UNION 2° PUMP BLITZ AND LINK	1	
31	X02.403.000	RACCORDO DIRITTO PG D.25 - 1"	STRAIGHT HOSE R. H D.25 - 1"	1	
32	XOR.003.112	OR D.28,24x2,62	O-RING D.28,24x2,62	2	
33	X00.045.012	RIDUZIONE 1" 1/4 M - 1" M	1" 1/4 M - 1" M REDUCER NIPPLE	1	
34	X00.058.028	RACCORDO DIRITTO PG D. 30	STRAIGHT HOSE R.H D.30	1	
35	X00.058.006	GIRELLO 1" 1/4 GAS	1" 1/4 FLY NUT	1	
36	X02.033.000	GUARNIZIONE PER BOCCHETTONE ASPIRAZIONE	GASKET	1	
37	X20.852.100	TUBO SPIRALATO D. 30 L= 1000	HOSE D. 30 L= 1000	1	

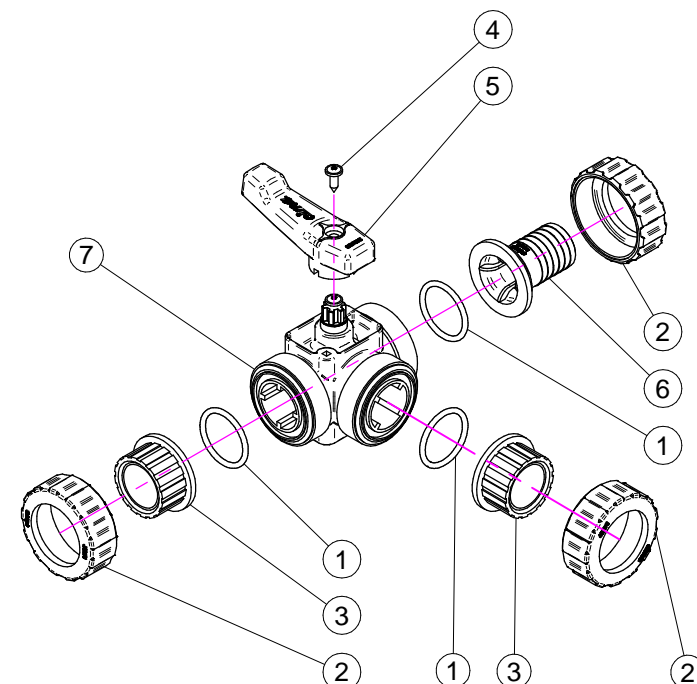
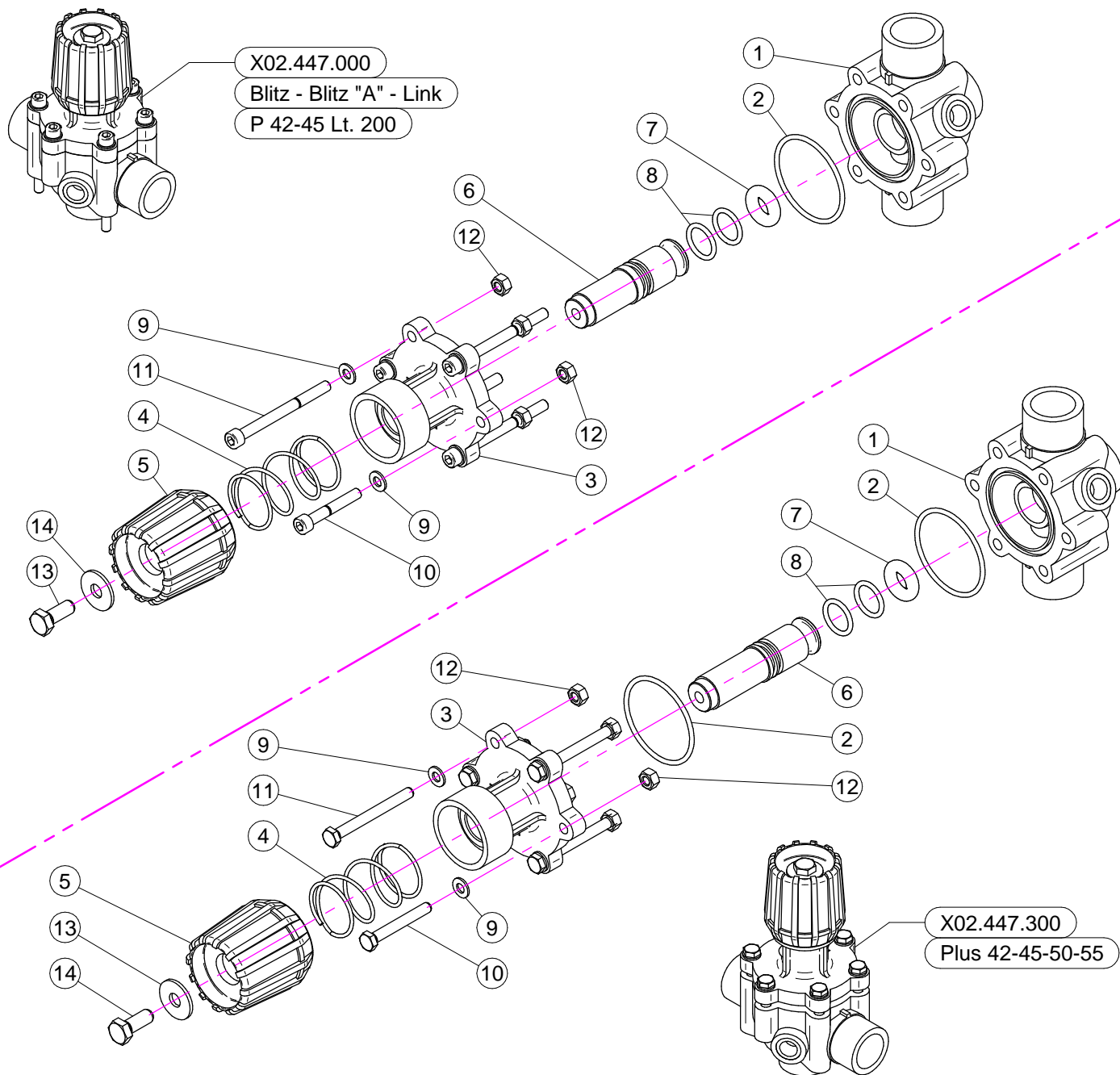

BLITZ - BLITZ "A" - LINK

N°	Doc. Number	Titolo	Title	Q.tà	Note
1	X02.447.001	CORPO VALVOLA DI REGOLAZIONE	BODY FOR REGULATION VALVE	1	
2	XOR.003.193	OR D.48,89x2,62	O-RING GASKET 48,89x2,62	1	
3	X02.447.009	FLANGIA SUPERIORE SERRANDA	UPPER FLANGE	1	
4	X02.447.011	MOLLA RECUPERO GIOCO	SPRING	1	
5	X02.447.010	MANOPOLA VALVOLA	REGULATION VALVE KNOB	1	
6	X02.447.014	PERNO PER REGOLATORE DI PRESSIONE	PIN	1	
7	X02.447.005	OR SPECIALE PER SERRANDA 2447	SPECIAL O-RING FOR GATE 2447	1	
8	XOR.003.068	OR D.17,12x2,62	O-RING GASKET 17,12x2,62	2	
9	XRP.006.000	RONDELLA PIANA D. 6	WASHER D.6	6	
10	XTCE.006 .040	VITE BRUGOLA TCE M6x40	BOLT TCE M6x40	2	
11	XTCE.006.070	VITE BRUGOLA TCE M6x70	BOLT TCE M6x70	4	
12	XD0.06.5588G	DADO M6	NUT M6	6	
13	XTE.008.025I	VITE TE 8X25 INOX	INOX 8X25 SCREW	1	
14	XRP.008.024I	RONDELLA PIANA LARGA D.8X24 INOX	INOX WASHER D.8X24	1	

N°	Doc. Number	Titolo	Title	Q.tà
1	XOR.004.137	OR D.34.52x3.53	O-RING D.34.52x3.53	3
2	X21.058.007	GHIERA VALVOLA 3 VIE	VALVE UNION NUT	3
3	X21.058.006	MANICOTTO VALVOLA 3 VIE	VALVE END CONNECTOR	2
4	XTA.05,5.016	VITE AUTOFILETTANTE M5,5 x 16	SELFTHREADED SCREW M5,5 x 16	1
5	X21.058.003	MANIGLIA VALVOLA 3 VIE	VALVE HANDLE	1
6	X21.058.009	PORTAGOMMA D.30 RUBINETTO A 3 VIE	RUBBER HOLDER D.30	1
7	X21.058.110	CORPO VALVOLA 3 VIE	BODY OF THREE WAYS VALVE	1

PLUS 42-45-50-55

N°	Doc. Number	Titolo	Title	Q.tà	Note
1	X02.447.001	CORPO VALVOLA DI REGOLAZIONE	BODY FOR REGULATION VALVE	1	
2	XOR.003.193	OR D.48,89x2,62	O-RING GASKET 48,89x2,62	2	
3	X02.447.012	FLANGIA SUPERIORE SERRANDA	UPPER FLANGE	1	
4	X02.447.011	MOLLA RECUPERO GIOCO	SPRING	1	
5	X02.447.010	MANOPOLA VALVOLA	REGULATION VALVE KNOB	1	
6	X02.447.013	PERNO IN NYLON PER VALVOLA	VALVE PIN	1	
7	X02.447.005	OR SPECIALE PER SERRANDA 2447	SPECIAL O-RING FOR GATE 2447	1	
8	XOR.003.068	OR D.17,12x2,62	O-RING GASKET 17,12x2,62	2	
9	XRP.006.000I	RONDELLA PIANA D. 6 INOX	INOX WASHER D.6	6	
10	XTE.006.045I	VITE TE M6x45 INOX	INOX M6x45 SCREW	2	
11	XTE.006.060I	VITE TE M6x60 INOX	INOX M6x60 TE SCREW	4	
12	XD0.06.5588GI	DADO M6 6S PG INOX	INOX M6 6S BIG LEAD NUT 5588	6	
13	XRP.008.024I	RONDELLA PIANA LARGA D.8X24 INOX	INOX WASHER D.8X24	1	
14	XTE.008.025I	VITE TE 8X25 INOX	INOX 8X25 SCREW	1	

CODICE-CODE
X02.450.100

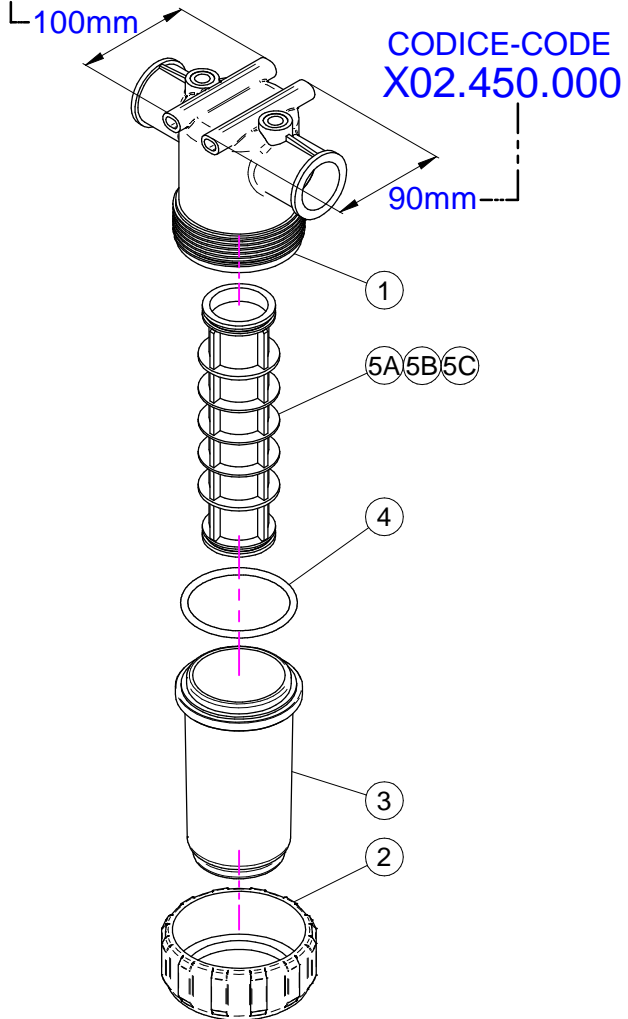

CODICE-CODE
X02.450.110

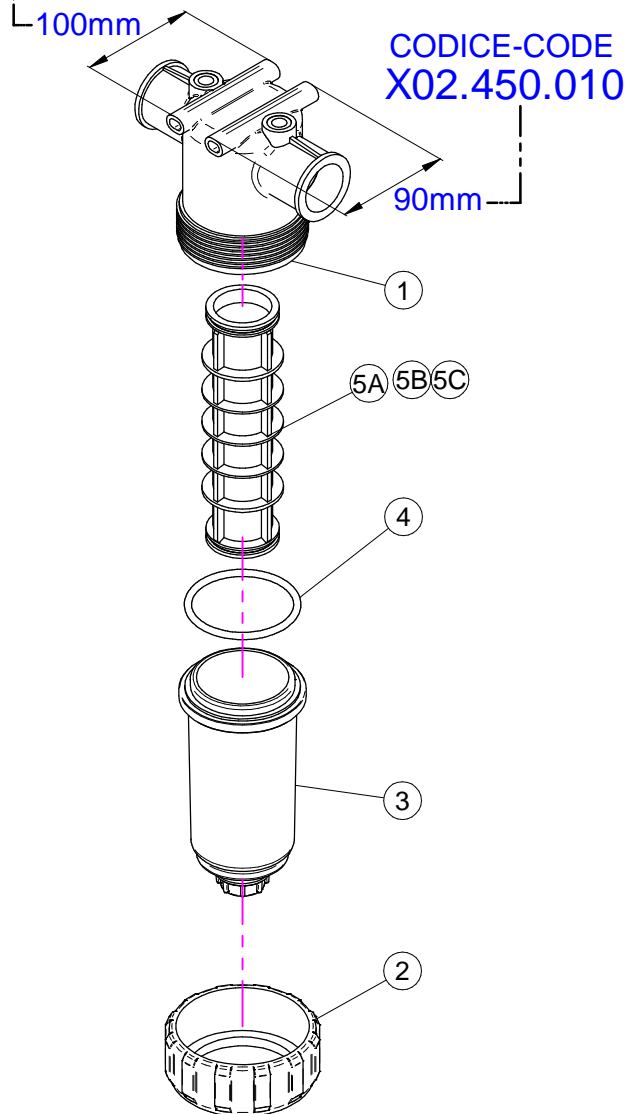

CODICE-CODE
X02.450.120

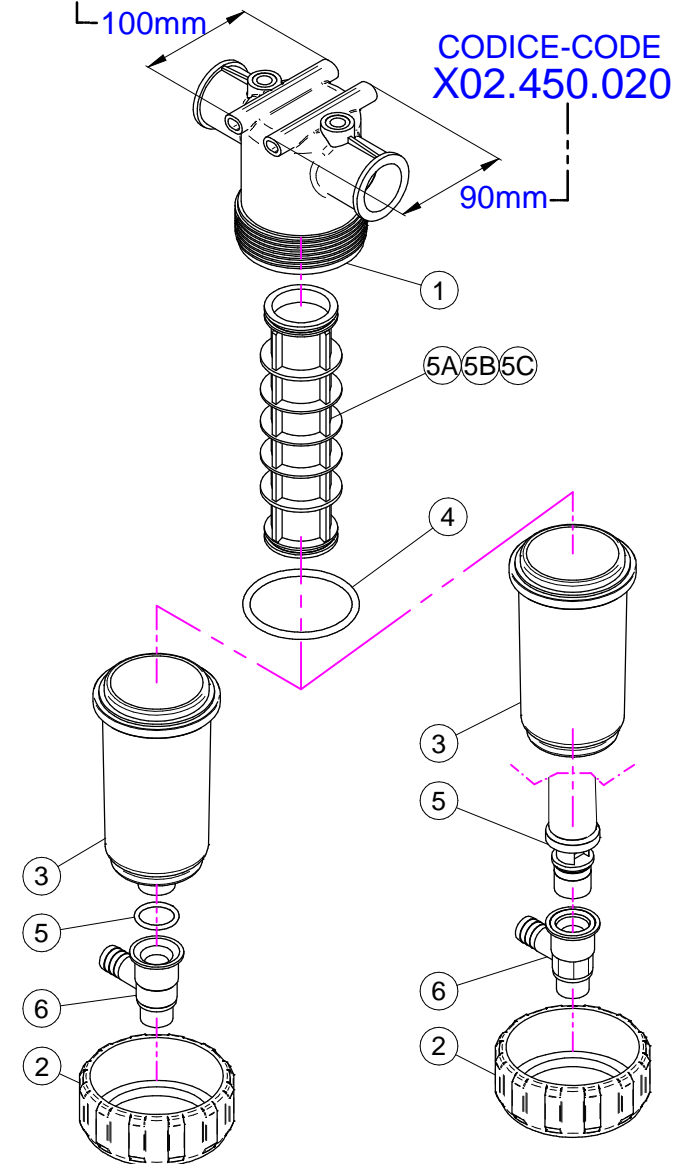

X02.450.100

N°	Doc. Number	Titolo	Title	Q.tà	Note
1	X02.450.101	CORPO FILTRO IN LINEA F. 1 1/4"	LINE FILTER BODY	1	
2	X02.450.003	GHIERA FILTRO IN LINEA	RING NUT FILTER IN LINE	1	
3	X02.450.002	COPERCHIO FILTRO	LID FILTER	1	
4	XOR.000.178	OR D.74,63x5,33	O-RING D.74,63x5,33	1	
5A	X02.450.004C	CARTUCCIA FILTRO CON OR 50 MESH (BLU)	CARTRIDGE WITH O-RING 50 MESH (BLUE)	1	
5B	X02.450.204C	CARTUCCIA FILTRO CON OR 80 MESH (GRIGIO)	CARTRIDGE WITH O-RING 80 MESH (GREY)	1	
5C	X02.450.104C	CARTUCCIA FILTRO CON OR 32 MESH (BIANCO)	CARTRIDGE WITH O-RING 32 MESH (WHITE)	1	

X02.450.000

N°	Doc. Number	Titolo	Title	Q.tà	Note
1	X02.450.001	CORPO FILTRO IN LINEA F. 1 1/4"	LINE FILTER BODY	1	
2	X02.450.003	GHIERA FILTRO IN LINEA	RING NUT FILTER IN LINE	1	
3	X02.450.002	COPERCHIO FILTRO	LID FILTER	1	
4	XOR.000.178	OR D.74,63x5,33	O-RING D.74,63x5,33	1	
5A	X02.450.004C	CARTUCCIA FILTRO CON OR 50 MESH (BLU)	CARTRIDGE WITH O-RING 50 MESH (BLUE)	1	
5B	X02.450.204C	CARTUCCIA FILTRO CON OR 80 MESH (GRIGIO)	CARTRIDGE WITH O-RING 80 MESH (GREY)	1	
5C	X02.450.104C	CARTUCCIA FILTRO CON OR 32 MESH (BIANCO)	CARTRIDGE WITH O-RING 32 MESH (WHITE)	1	

X02.450.110

N°	Doc. Number	Titolo	Title	Q.tà	Note
1	X02.450.101	CORPO FILTRO IN LINEA F. 1 1/4"	LINE FILTER BODY	1	
2	X02.450.003	GHIERA FILTRO IN LINEA	RING NUT FILTER IN LINE	1	
3	X02.450.011	COPERCHIO FILTRO CON SCARICO D.3/4"	LID FILTER WITH UNLOADING	1	
4	XOR.000.178	OR D.74,63x5,33	O-RING D.74,63x5,33	1	
5	X02.182.000	TAPPO 3/4" FEMMINA	FEMALE 3/4" CAP	1	
6	X02.030.010	GUARNIZIONE TAPPO DISTRIBUTORE	GASKET	1	
5A	X02.450.004C	CARTUCCIA FILTRO CON OR 50 MESH (BLU)	CARTRIDGE WITH O-RING 50 MESH (BLUE)	1	
5B	X02.450.204C	CARTUCCIA FILTRO CON OR 80 MESH (GRIGIO)	CARTRIDGE WITH O-RING 80 MESH (GREY)	1	
5C	X02.450.104C	CARTUCCIA FILTRO CON OR 32 MESH (BIANCO)	CARTRIDGE WITH O-RING 32 MESH (WHITE)	1	

X02.450.010

N°	Doc. Number	Titolo	Title	Q.tà	Note
1	X02.450.001	CORPO FILTRO IN LINEA F. 1 1/4"	LINE FILTER BODY	1	
2	X02.450.003	GHIERA FILTRO IN LINEA	RING NUT FILTER IN LINE	1	
3	X02.450.011	COPERCHIO FILTRO CON SCARICO D.3/4"	LID FILTER WITH UNLOADING	1	
4	XOR.000.178	OR D.74,63x5,33	O-RING D.74,63x5,33	1	
5	X02.182.000	TAPPO 3/4" FEMMINA	FEMALE 3/4" CAP	1	
6	X02.030.010	GUARNIZIONE TAPPO DISTRIBUTORE	GASKET	1	
5A	X02.450.004C	CARTUCCIA FILTRO CON OR 50 MESH (BLU)	CARTRIDGE WITH O-RING 50 MESH (BLUE)	1	
5B	X02.450.204C	CARTUCCIA FILTRO CON OR 80 MESH (GRIGIO)	CARTRIDGE WITH O-RING 80 MESH (GREY)	1	
5C	X02.450.104C	CARTUCCIA FILTRO CON OR 32 MESH (BIANCO)	CARTRIDGE WITH O-RING 32 MESH (WHITE)	1	

X02.450.120

N°	Doc. Number	Titolo	Title	Q.tà	Note
1	X02.450.101	CORPO FILTRO IN LINEA F. 1 1/4"	LINE FILTER BODY	1	
2	X02.450.003	GHIERA FILTRO IN LINEA	RING NUT FILTER IN LINE	1	
3	X02.450.011	COPERCHIO FILTRO CON SCARICO D.3/4"	LID FILTER WITH UNLOADING	1	
4	XOR.000.178	OR D.74,63x5,33	O-RING D.74,63x5,33	1	
5	XOR.000.134	OR D.25,8x3,53	O-RING D.25,8x3,53	1	
6	X02.450.120.D	RUBINETTO AUTOPULENTE PER FILTRO	FAUCET FOR FILTER	1	
7A	X02.450.004C	CARTUCCIA FILTRO CON OR 50 MESH (BLU)	CARTRIDGE WITH O-RING 50 MESH (BLUE)	1	
7B	X02.450.204C	CARTUCCIA FILTRO CON OR 80 MESH (GRIGIO)	CARTRIDGE WITH O-RING 80 MESH (GREY)	1	
7C	X02.450.104C	CARTUCCIA FILTRO CON OR 32 MESH (BIANCO)	CARTRIDGE WITH O-RING 32 MESH (WHITE)	1	

X02.450.020

N°	Doc. Number	Titolo	Title	Q.tà	Note
1	X02.450.001	CORPO FILTRO IN LINEA F. 1 1/4"	LINE FILTER BODY	1	
2	X02.450.003	GHIERA FILTRO IN LINEA	RING NUT FILTER IN LINE	1	
3	X02.450.020.A	COPERCHIO FILTRO IN LINEA 1" 1/4	LINE FILTER LID 1" 1/4	1	
4	XOR.000.178	OR D.74,63x5,33	O-RING D.74,63x5,33	1	
5	X02.450.020.B	CORPO CENTRALE CON TAPPO 1" 1/4	CENTRAL BODY WITH CAP 1" 1/4	1	
6	X02.450.020.D	RUBINETTO AUTOPULENTE PER FILTRO	FAUCET FOR FILTER	1	
7A	X02.450.004C	CARTUCCIA FILTRO CON OR 50 MESH (BLU)	CARTRIDGE WITH O-RING 50 MESH (BLUE)	1	
7B	X02.450.204C	CARTUCCIA FILTRO CON OR 80 MESH (GRIGIO)	CARTRIDGE WITH O-RING 80 MESH (GREY)	1	
7C	X02.450.104C	CARTUCCIA FILTRO CON OR 32 MESH (BIANCO)	CARTRIDGE WITH O-RING 32 MESH (WHITE)	1	

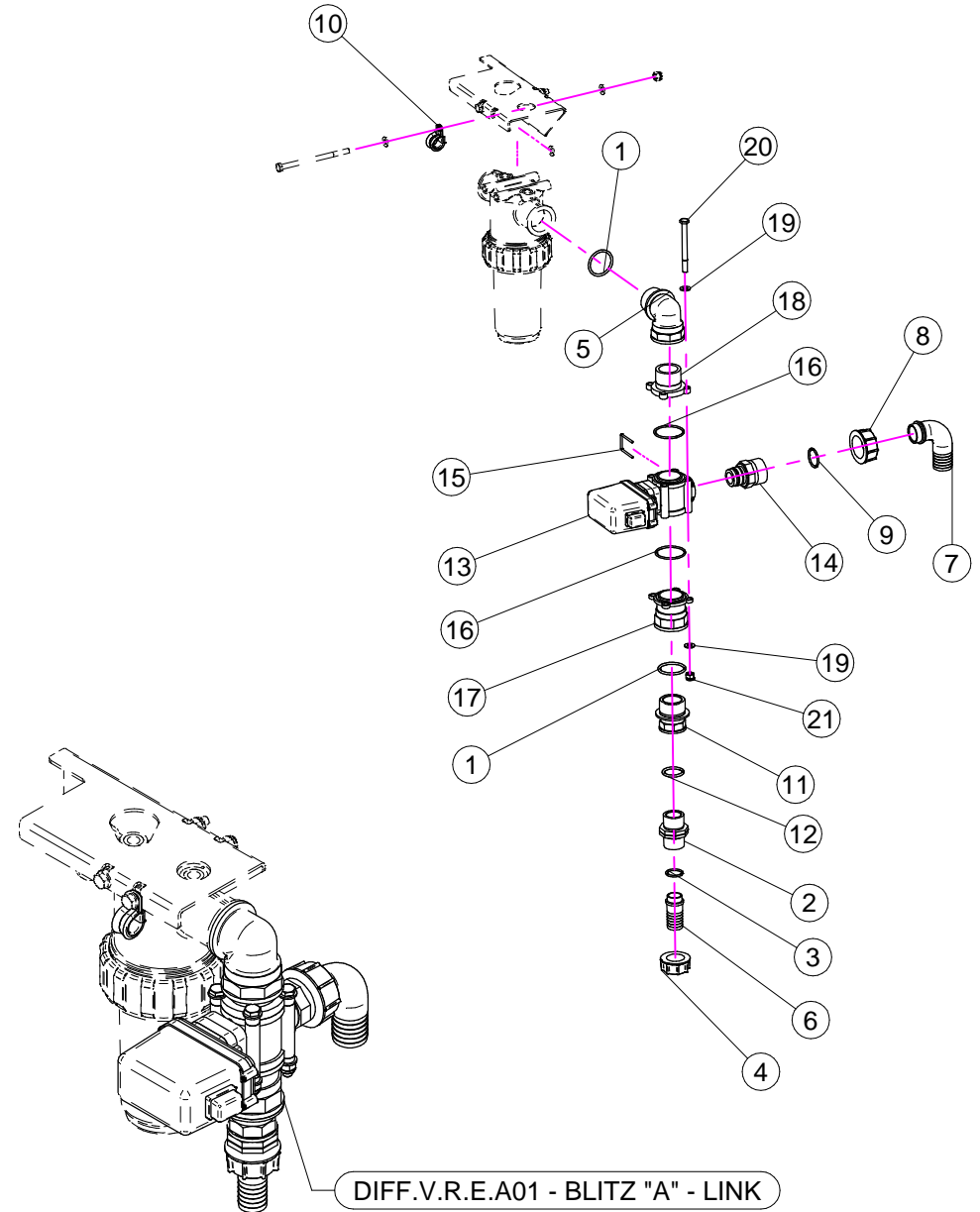
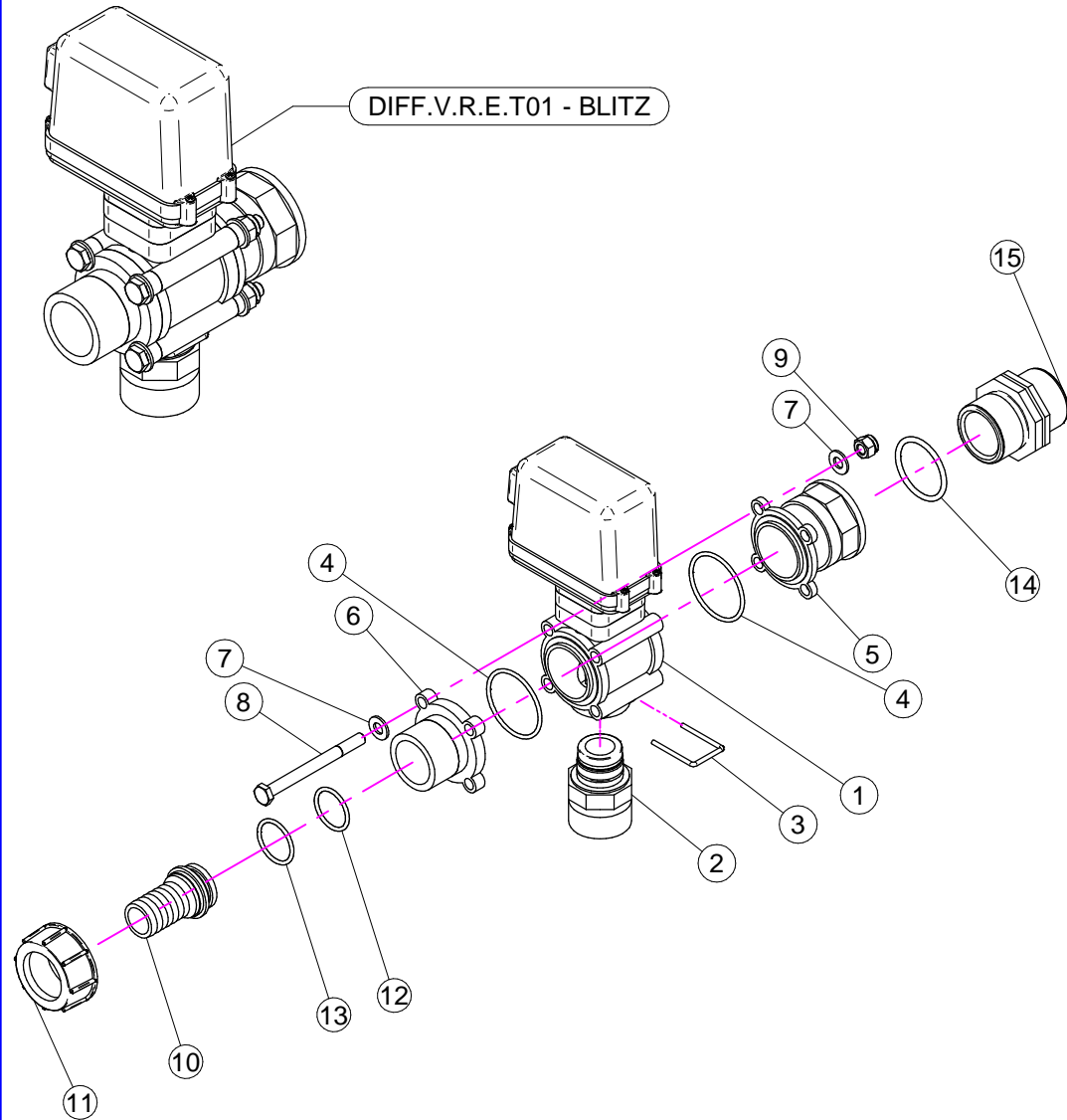

DIFF.V.R.E.T01
BLITZ

N°	Doc. Number	Titolo	Title	Q.tà	Note
1	X21.130.000	VALVOLA MOTORIZZATA PROPORZIONALE	ELECTRIC PROPORTIONAL VALVE	1	
2	X21.131.000	RIDUZIONE ATT.RAP. G 1" 1/4	REDUCTION J. F. G 1" 1/4	1	
3	X21.130.005	FORCHETTA ATTACCO RAPIDO	FORK FASTNER JOINT	1	
4	XOR.003.181	OR D. 45,69x50,93x2,62	45,69x50,93x2,62 O-RING	2	
5	X21.133.000	RACCORDO FLANGIATO 1" - 1 1/4"	CONNECTOR	1	
6	X21.132.000	FLANGIA VALVOLE	VALVE FLANGE	1	
7	XRP.008.000	RONDELLA PIANA D.8	WASHER D.8	8	
8	XTE.008.090	VITE TE M8 x 90	SCREW TE M8 x 90	4	
9	XDA.008.0AG	DADO AUTOBLOCCANTE M8	SELF LOCKING NUT M8	4	
10	X02.363.000	RACCORDO DIRITTO PG D.25 - 1 1/4	STRAIGHT HOSE R.H D.25 - 1 1/4	1	
11	X00.058.006	GIRELLO 1" 1/4 GAS	1" 1/4 FLY NUT	1	
12	XOR.003.106	OR D.26.65x2.62	O-RING D.26.65x2.62	1	
13	XOR.003.112	OR D.28,24x2,62	O-RING D.28,24x2,62	1	
14	XOR.000.144	OR D.39,69x3,53	O-RING D.39,69x3,53	1	
15	X00.345.010	NIPPLO 1" 1/4 + 1" 1/4 GAS	NIPPLE 1" 1/4 + 1" 1/4 GAS	1	

DIFF.V.R.E.A01
BLITZ "A" - LINK

N°	Doc. Number	Titolo	Title	Q.tà	Note
1	XOR.000.144	OR D.39,69x3,53	O-RING D.39,69x3,53	2	
2	X00.055.034	NIPPLO 1" / 1" GAS	NIPPLE 1" / 1" GAS	1	
3	XOR.000.132	OR D.23,81 x 2,62	23,81 x 2,62 O-RING GASKET	1	
4	X00.055.24.2	GIRELLO 1" GAS	1" FLY NUT	1	
5	X24.070.000	RACCORDO CURVO M-F 1"1/4	HOSETAIL 1"1/4	1	
6	X00.055.021	RACCORDO DIRITTO PG D.25	STRAIGHT HOSE R.H D.25	1	
7	X00.058.004	RACCORDO CURVO P.G. D.30	D.30 HOSETAIL	1	
8	X00.058.006	GIRELLO 1" 1/4 GAS	1" 1/4 FLY NUT	1	
9	XOR.003.112	OR D.28,24x2,62	O-RING D.28,24x2,62	1	
10	XFG.018.000	FASCETTA GOMMATA PER TUBI D.18	STICKER	1	
11	X02.374.000	RIDUZIONE M/F 1" F / 1"1/4M	M. / F. 1" F / 1"1/4M REDUCTION	1	
12	XOR.004.118	OR D.29,75 x 3,53	29,75 x 3,53 O-RING GASKET	1	
13	X21.130.000	VALVOLA MOTORIZZATA PROPORZIONALE	ELECTRIC PROPORTIONAL VALVE	1	
14	X21.131.000	RIDUZIONE ATT.RAP. G 1" 1/4	REDUCTION J. F. G 1" 1/4	1	
15	X21.130.005	FORCHETTA ATTACCO RAPIDO	FORK FASTNER JOINT	1	
16	XOR.003.181	OR D. 45,69x50,93x2,62	45,69x50,93x2,62 O-RING	2	
17	X21.133.000	RACCORDO FLANGIATO 1" - 1 1/4"	CONNECTOR	1	
18	X21.132.000	FLANGIA VALVOLE	VALVE FLANGE	1	
19	XRP.008.000	RONDELLA PIANA D.8	WASHER D.8	8	
20	XTE.008.090	VITE TE M8 x 90	SCREW TE M8 x 90	4	
21	XDA.008.0AG	DADO AUTOBLOCCANTE M8	SELF LOCKING NUT M8	4	

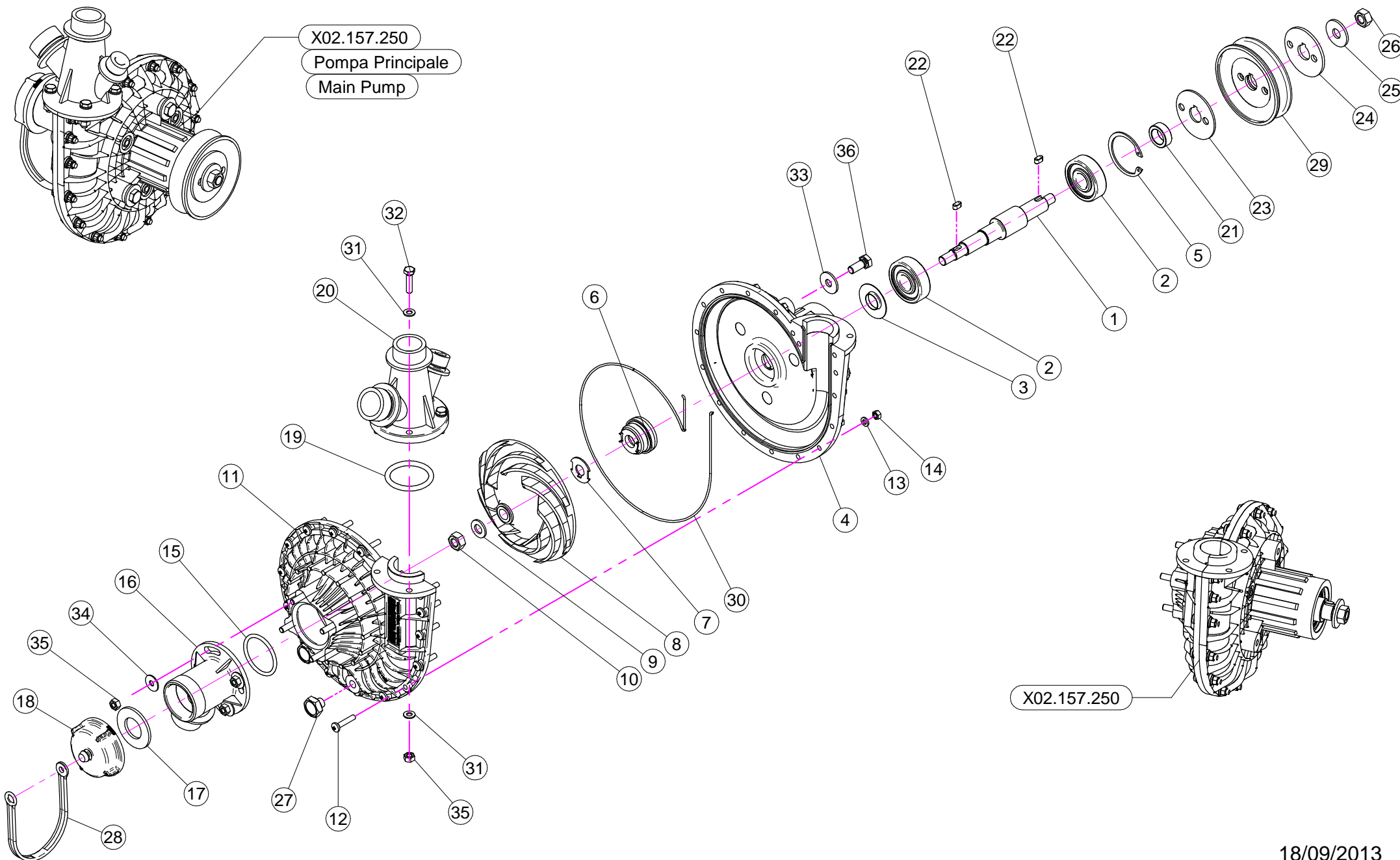

N°	Doc. Number	Titolo	Title	Q.tà	Note
1	X02.155.010	ALBERO POMPA CD 32 INOX LUNGO	CD32 PUMP SHAFT	1	
2	XK6.303.2RS	CUSCINETTO A SFERE	ROLLER BEARING	2	
3	X20.406.000	COPERCHIETTO SPECIALE POMPA CD 32	SPECIAL COVER FOR PUMP	1	
4	X02.151.011	CORPO POMPA CD 32 LUNGO	PUMP CASING MODEL 2013	1	
5	XI0.047.000	ANELLO ELASTICO INTERNO D.47	INTERNAL D.47 CIRCLIP	1	
6	X00.085.024CS	TENUTA MECCANICA	MECHANICAL SEAL	1	
7	X02.114.000	RONDELLA SPECIALE INOX	INOX SPECIAL WASHER	1	
8	X02.153.000	GIRANTE POMPA CD 32	CD 32 PUMP IMPELLER	1	
9	XRP.010.00I	RONDELLA PIANA D.10 INOX	WASHER D.10 INOX	1	
10	XDOT.10.5587	DADO OTTONE M10	M10 BRASS NUT	1	
11	X02.152.010	COPERCHIO POMPA CD 32	HOUSING	1	
12	XTC.05.25.85	VITE TESTA A CROCE 48 M5X25	CROSS SLOTTED SCREW M5X25	17	
13	XRP.005.000	RONDELLA PIANA D.5	WASHER D.5	17	
14	XDOT.05.5587	DADO OTTONE M5 (5587)	M5 BRASS NUT (5587)	17	
15	XOR.000.144	OR D.39,69x3,53	O-RING D.39,69x3,53	1	
16	X02.116.000	RACCORDO DI ASPIRAZIONE	SUCTION FITTING	1	
17	X02.130.000	GUARNIZIONE IN GOMMA DIAM. 24X46X3	24X46X3 RUBBER GASKET	1	
18	X02.120.000	TAPPO A FILETTO RAPIDO M47 x 5	RAPID THREAD CAP	1	
19	XOR.006.162	OR D.40,65 x 5,34	O-RING GASKET 40,65 x 5,34	1	
20	X02.113.001	RACCORDO DI MANDATA	DELIVERY FITTING	1	
21	X02.722.000	DISTANZIALE POMPA	BUSH	1	
22	XL.05.05.10	LINGUETTA 5X5X10	5X5X10 TANG	2	
23	X02.723.005	RONDELLA SPECIALE mm2	SPECIAL WASHER mm2	1	
24	X02.723.001	RONDELLA SPECIALE mm3	SPECIAL WASHER mm3	1	
25	XRP.010.030	RONDELLA PIANA D.10 x 30 mm	WASHER D.10 x 30 mm	1	
26	XD0.10.5588G	DADO M 10 6S PG	M10 6S BIG LEAD NUT 5588	1	
27	XTM.010.015	TAPPO M10X1,5	M10X1,5 CAP	2	
28	X21.183.000	STRISCIA FERMATAPPI	CAP STOP	1	
29	X02.723.002	PULEGGIA COMANDO POMPA D.82,5 X 1 3V	PULLEY FOR PUMP D.82,5 X 1 3V	1	
30	XOR.C02.070	CORDA OR D.2 L=700	OR CORD D.2 L=700	1	
31	XRP.006.000	RONDELLA PIANA D. 6	WASHER D.6	8	
32	XTE.006.025T	VITE TE M6X25	SCREW TE M6X25	4	
33	XRP.008.024	RONDELLA PIANA LARGA D.8X24	WASHER D.8X24	3	
34	XRP.006.018	RONDELLA PIANA D. 6x18	WASHER D.6x18	4	
35	XDOT.06.5587	DADO OTTONE M6	M6 BRASS NUT 5587	8	
36	XTE.008.020T	VITE TE 8x20	SCREW TE 8x20	3	

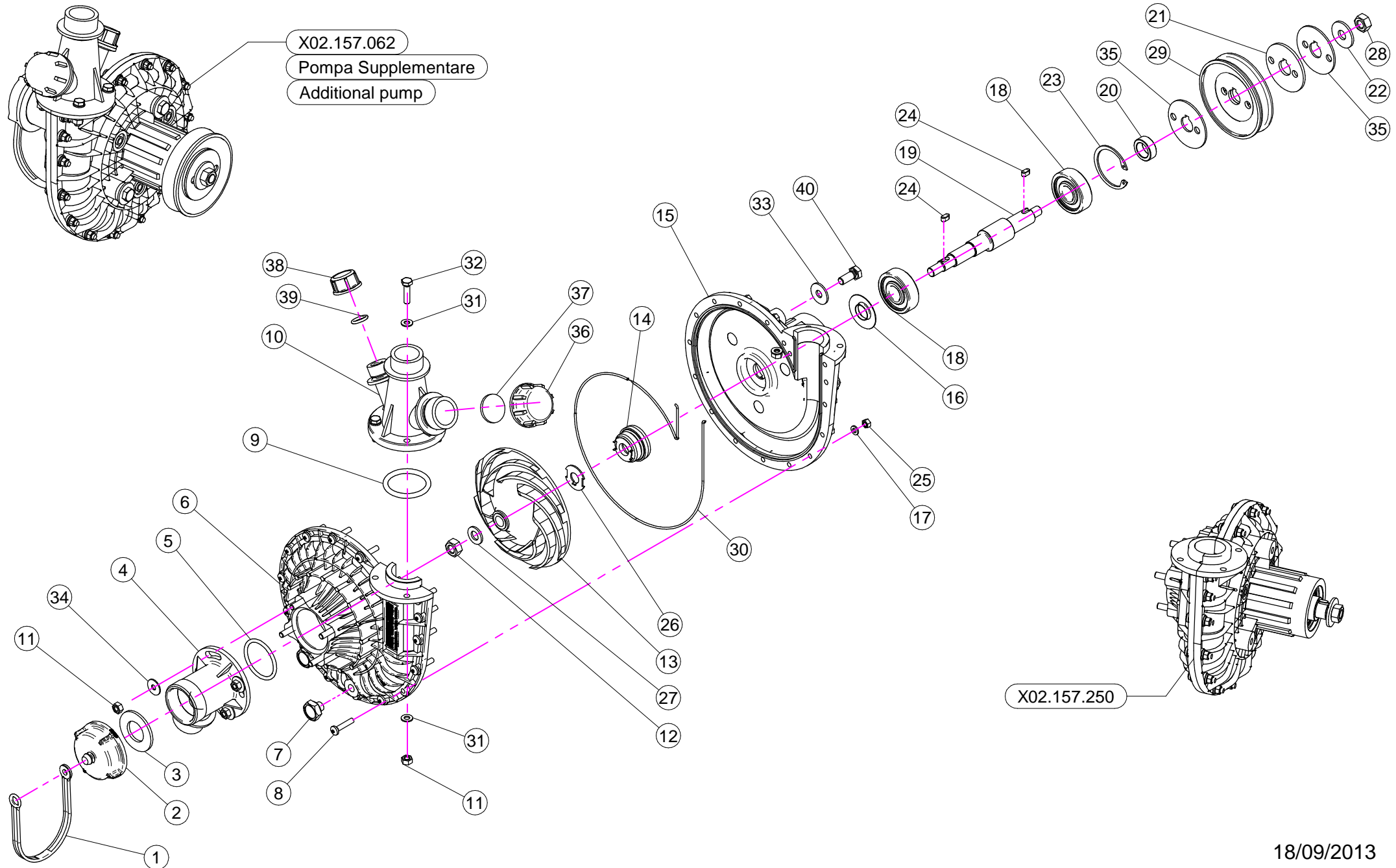

N°	Doc. Number	Titolo	Title	Qtà	Note
1	X21.183.000	STRISCIA FERMATAPPI	CAP STOP	1	
2	X02.120.000	TAPPO A FILETTO RAPIDO M47 x 5	RAPID THREAD CAP	1	
3	X02.130.000	GUARNIZIONE IN GOMMA DIAM. 24X46X3	24X46X3 RUBBER GASKET	1	
4	X02.116.000	RACCORDO DI ASPIRAZIONE	SUCTION FITTING	1	
5	XOR.000.144	OR D.39,69x3,53	O-RING D.39,69x3,53	1	
6	X02.152.010	COPERCHIO POMPA CD 32	HOUSING	1	
7	XTM.010.015	TAPPO M10X1,5	M10X1,5 CAP	2	
8	XTC.05.25.85	VITE TESTA A CROCE 48 M5X25	CROSS SLOTTED SCREW M5X25	17	
9	XOR.006.162	OR D.40,65 x 5,34	O-RING GASKET 40,65 x 5,34	1	
10	X02.113.001	RACCORDO DI MANDATA	DELIVERY FITTING	1	
11	XDOT.06.5587	DADO OTTONE M6	M6 BRASS NUT 5587	8	
12	XDOT.10.5587	DADO OTTONE M10	M10 BRASS NUT	1	
13	X02.153.000	GIRANTE POMPA CD 32	CD 32 PUMP IMPELLER	1	
14	X00.085.024CS	TENUTA MECCANICA	MECHANICAL SEAL	1	
15	X02.151.011	CORPO POMPA CD 32 LUNGO	PUMP CASING MODEL 2013	1	
16	X20.406.000	COPERCHIETTO SPECIALE POMPA CD 32	SPECIAL COVER FOR PUMP	1	
17	XRP.005.000	RONDELLA PIANA D.5	WASHER D.5	17	
18	XK6.303.2RS	CUSCINETTO A SFERE	ROLLER BEARING	2	
19	X02.155.010	ALBERO POMPA CD 32 INOX LUNGO	CD32 PUMP SHAFT	1	
20	X02.722.000	DISTANZIALE POMPA	BUSH	1	
21	X02.723.001	RONDELLA SPECIALE mm3	SPECIAL WASHER mm3	1	
22	XRP.010.030	RONDELLA PIANA D.10 x 30 mm	WASHER D.10 x 30 mm	1	
23	XI0.047.000	ANELLO ELASTICO INTERNO D.47	INTERNAL D.47 CIRCLIP	1	
24	XL.05.05.10	LINGUETTA 5X5X10	5X5X10 TANG	2	
25	XDOT.05.5587	DADO OTTONE M5 (5587)	M5 BRASS NUT (5587)	17	
26	X02.114.000	RONDELLA SPECIALE INOX	INOX SPECIAL WASHER	1	
27	XRP.010.001	RONDELLA PIANA D.10 INOX	WASHER D.10 INOX	1	
28	XD0.10.5588G	DADO M 10 6S PG	M10 6S BIG LEAD NUT 5588	1	
29	X02.723.000	PULEGGIA COMANDO POMPA D.88 X 1 3V	PULLEY FOR PUMP D.88 X 1 3V	1	
30	XOR.C02.070	CORDA OR D.2 L=700	OR CORD D.2 L=700	1	
31	XRP.006.000	RONDELLA PIANA D. 6	WASHER D.6	8	
32	XTE.006.025T	VITE TE M6X25	SCREW TE M6X25	4	
33	XRP.008.024	RONDELLA PIANA LARGA D.8X24	WASHER D.8X24	3	
34	XRP.006.018	RONDELLA PIANA D. 6x18	WASHER D.6x18	4	
35	X02.723.005	RONDELLA SPECIALE mm2	SPECIAL WASHER mm2	2	
36	XTF.001.000	TAPPO 1"	PACKING	1	
37	X24.100.000	GUARNIZIONE PIANA D.30x3 PER TAPPO D. 1"	GASKET D.30 x 3	1	
38	XTF.012.000	TAPPO F. DA 1/2" GAS	BLANK CAP 1/2"	1	
39	XOR.000.117	OR D. 13,1x18,34x2,62	13,1x18,34x2,62 O-RING GASKET	1	
40	XTE.008.020T	VITE TE 8x20	SCREW TE 8x20	3	

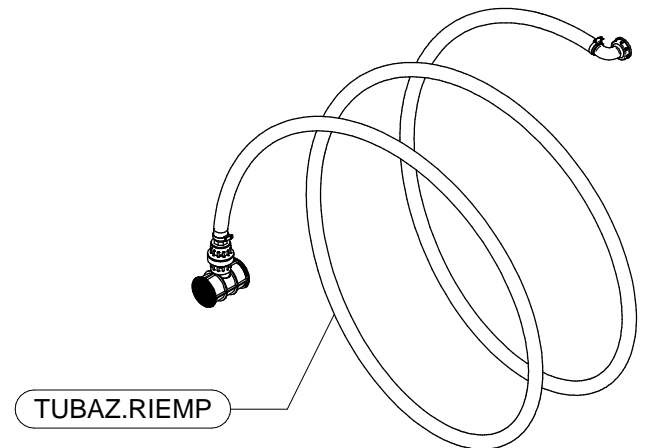
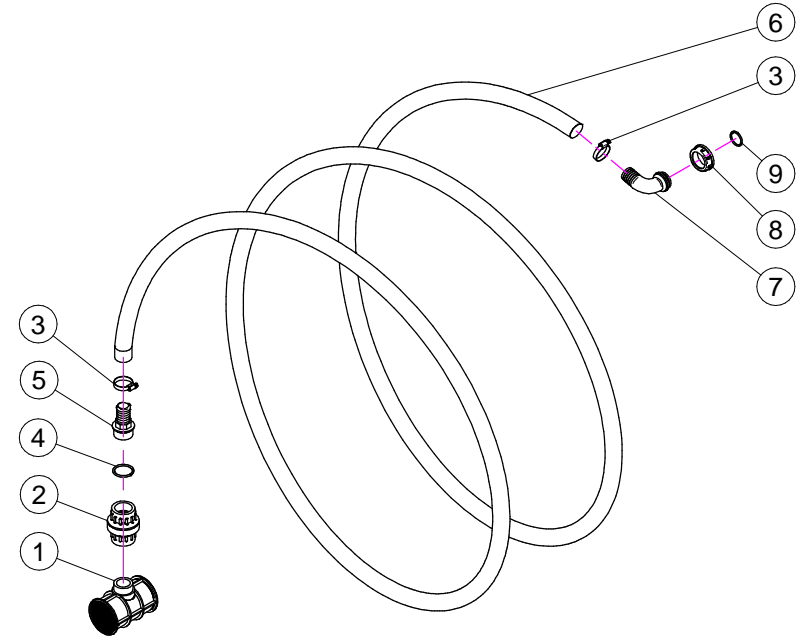
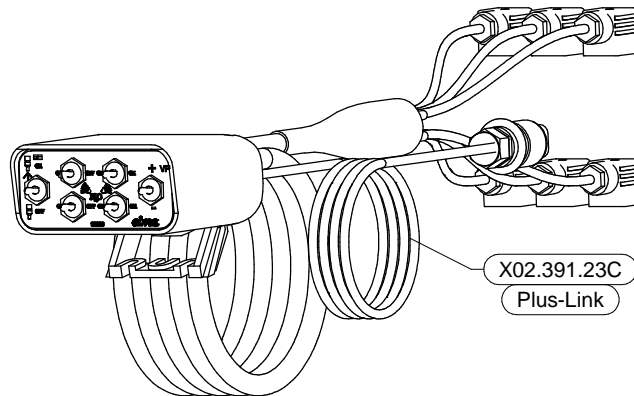
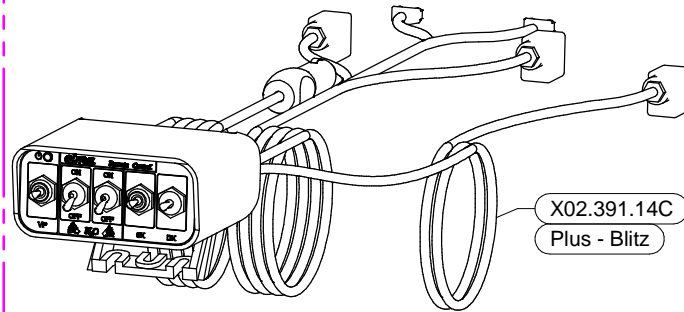
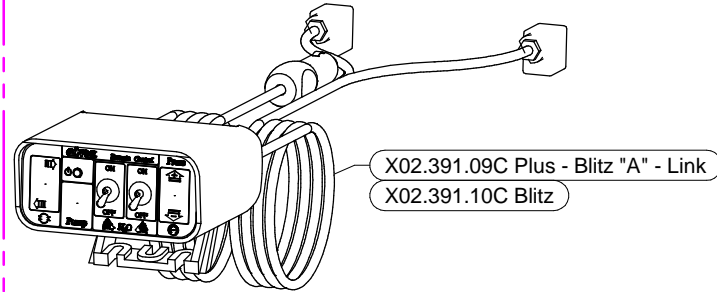
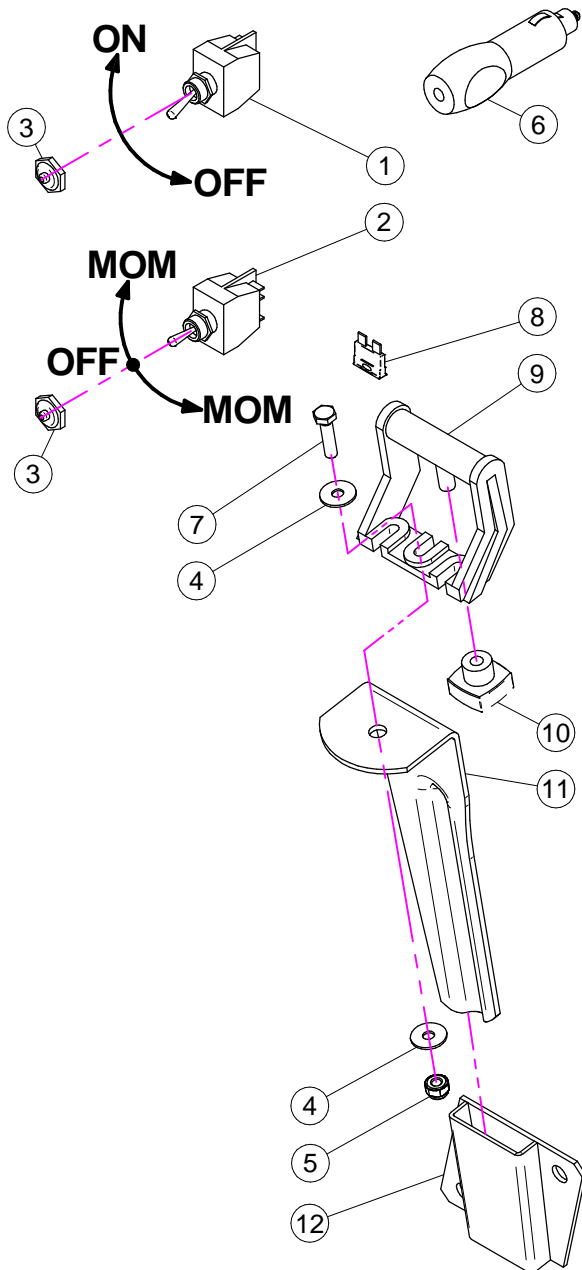

X02.391.09C / 10C / 14C / 23C

N°	Doc. Number	Titolo	Title	Q.tà	Note
1	X21.030.005	DEVIATORE 2V 2P ON-OFF 10A	SWITCH 2V 2P ON-OFF 10A	1	
2	X21.030.006	DEVIATORE MOM - 0 - MOM 10A	SWITCH MOM - 0 - MOM 10A	1	
3	X21.030.007	CAPPUCCIO INTERRUTTORE D.12	SWITCH CAP D.12	2	
4	XRP.006.018	RONDELLA PIANA D. 6x18	WASHER D.6x18	2	
5	XDA.006.0AG	DADO AUTOBLOCCANTE M6 ALTO PG	SELF-LOCKING NUT - HIGH M6	1	
6	X21.030.008	CONNETTORE DI ALIMENTAZIONE 12V	12V POWER JACK	1	
7	XTE.006.025T	VITE TE M6X25	SCREW TE M6X25	1	
8	X21.030.004	FUSIBILE - 10 Ah	10 Ah FUSE	1	
9	X21.030.002	STAFFA DI FISSAGGIO MOBILE	MOVING FIXING BRACKET	1	
10	X21.030.003	POMELLO DI BLOCCAGGIO	FIXING KNOB	1	
11	X20.111.000	STAFFA PORTA BAIONETTA	BRACKET	1	
12	X20.107.000	SUPPORTO A BAIONETTA FEMMINA	FEMALE BAYONET SUPPORT	1	

TUBAZ.RIEMP

N°	Doc. Number	Titolo	Title	Q.tà	Note
1	X00.611.000	FILTRO A T PER TUBAZIONE RIEMPIMENTO	T FILTER	1	
2	X00.300.000	VALVOLA DI FONDO F-F 1" 1/4	FOOT VALVE F-F 1" 1/4	1	
3	XF0.025.040I	FASCETTA A VITE 25/40 W4 INOX	STAINLESS STEEL CLIP	2	
4	XOR.000.144	OR D.39,69x3,53	O-RING D.39,69x3,53	1	
5	X00.423.000	RACCORDO DIRITTO PG 30 FIL.1" 1/4 GAS	MALE CONNECTOR RH 30 1" 1/4 GAS	1	
6	X02.238.450	TUBO SPIRALATO D.30 L=4500	SPIRAL HOSE D.30 L=4500	1	
7	X00.481.000	RACCORDO CURVO P.G. D.30	D.30 HOSETAIL	1	
8	X02.165.000	GIRELLO A FILETTO RAPIDO	RAPID THREAD FLY NUT	1	
9	XOR.000.508	OR D.30 x 3	30 x 3 O-RING GASKET	1	

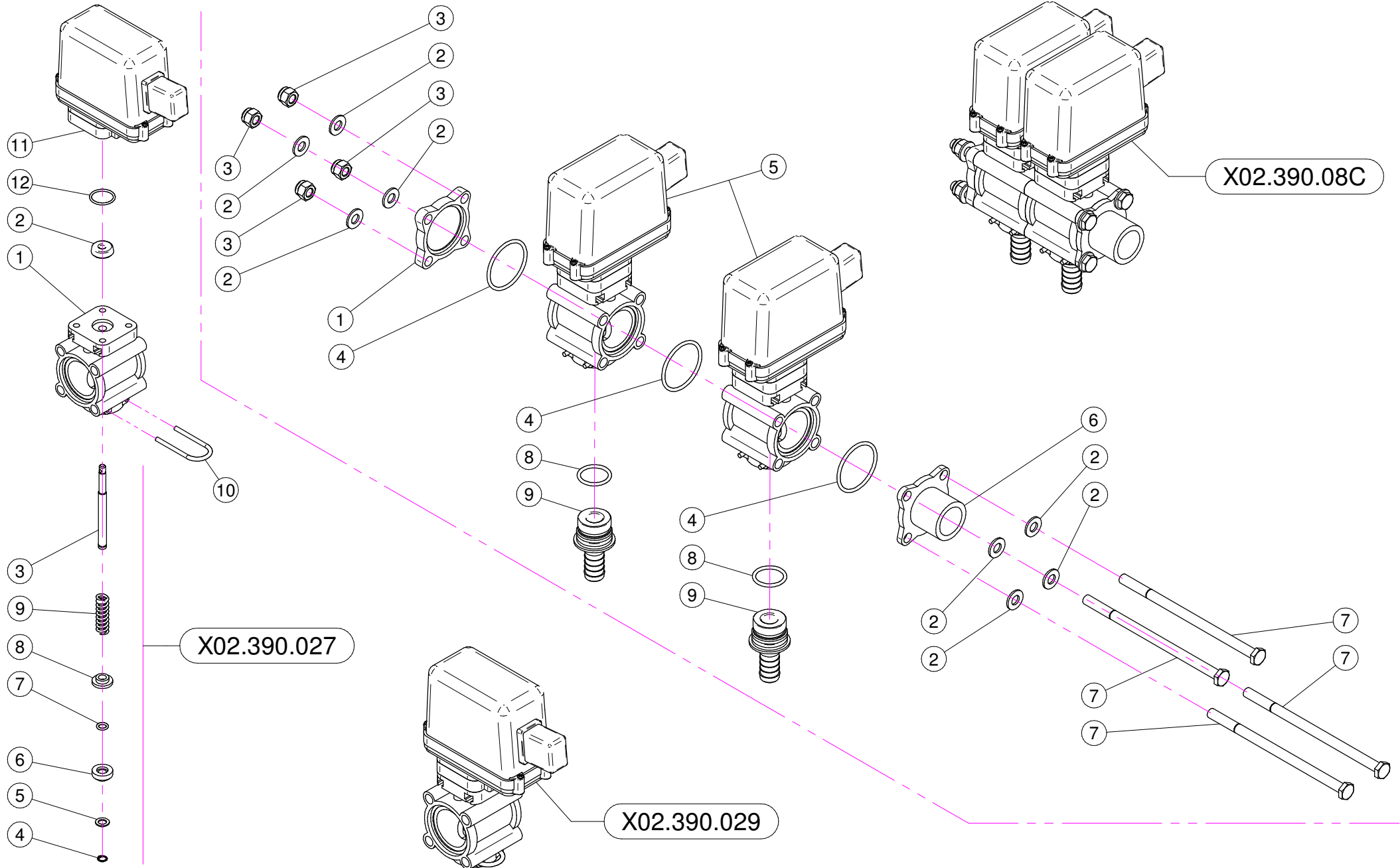

X02.390.029

N°	Doc. Number	Titolo	Title	Q.tà	Note
1	X02.390.007	CORPO VALVOLA	VALVE BODY	1	
2	X02.390.008	GUARNIZIONE D.6x17x6 VITON	GASKET	1	
3	X02.390.020	PERNO VALVOLA MANUALE INOX	PIN	1	
4	X02.390.013	ANELLO ARRESTO	STOP RING	1	
5	X02.390.014	RONDELLA PIANA 7,2 x 12 INOX	WASHER 7,2 x 12 INOX	1	
6	X02.390.015	PIATTELLO INFERIORE VALVOLA	LOWER PIATTELLO VALVE	1	
7	X02.390.016	OR 6,7 x 1,78	O RING	1	
8	X02.390.009	PIATTELLO SUPERIORE VALVOLE	SUPERIOR PIATTELLO VALVES	1	
9	X02.390.011	MOLLA DI RITEGNO	SPRING	1	
10	X21.130.005	FORCHETTA PER RUB. MAN. SEMP. PR	FORK	1	
11	X02.390.028	ELETTROVALVOLA COMPLETA ARAG BLU	SOLENOID VALVE	1	
12	XOR.002.075	OR D.18.77 X 1.78	D.18.77 X 1.78 O-RING	1	

X02.390.08C

N°	Doc. Number	Titolo	Title	Q.tà	Note
1	X02.390.017	FLANGIA VALVOLE	VALVE FLANGE	1	
2	XRP.008.000	RONDELLA PIANA D.8	WASHER D.8	8	
3	XDA.008.0AG	DADO AUTOBLOCCANTE M8	SELF LOCKING NUT M8	4	
4	XOR.003.156	OR D.39,34x2,62	O-RING GASKET 39,34x2,62	3	
5	X02.390.029	ELETTROVALVOLA COMPLETA ARAG BLU	SOLENOID VALVE	2	
6	X02.390.018	RACCORDO FLANGIATO 1" GAS	CONNECTOR	1	
7	XTE.008.150	VITE TE M8x150	SCREW TE M8 x 150	4	
8	XOR.000.130	OR D.22,22 x 2,62	22,22 x 2,62 O-RING GASKET	2	
9	X02.406.000	PORTAGOMMA D.16 ATT.RAP. PER ELETT.	HOSETAIL D.16	2	

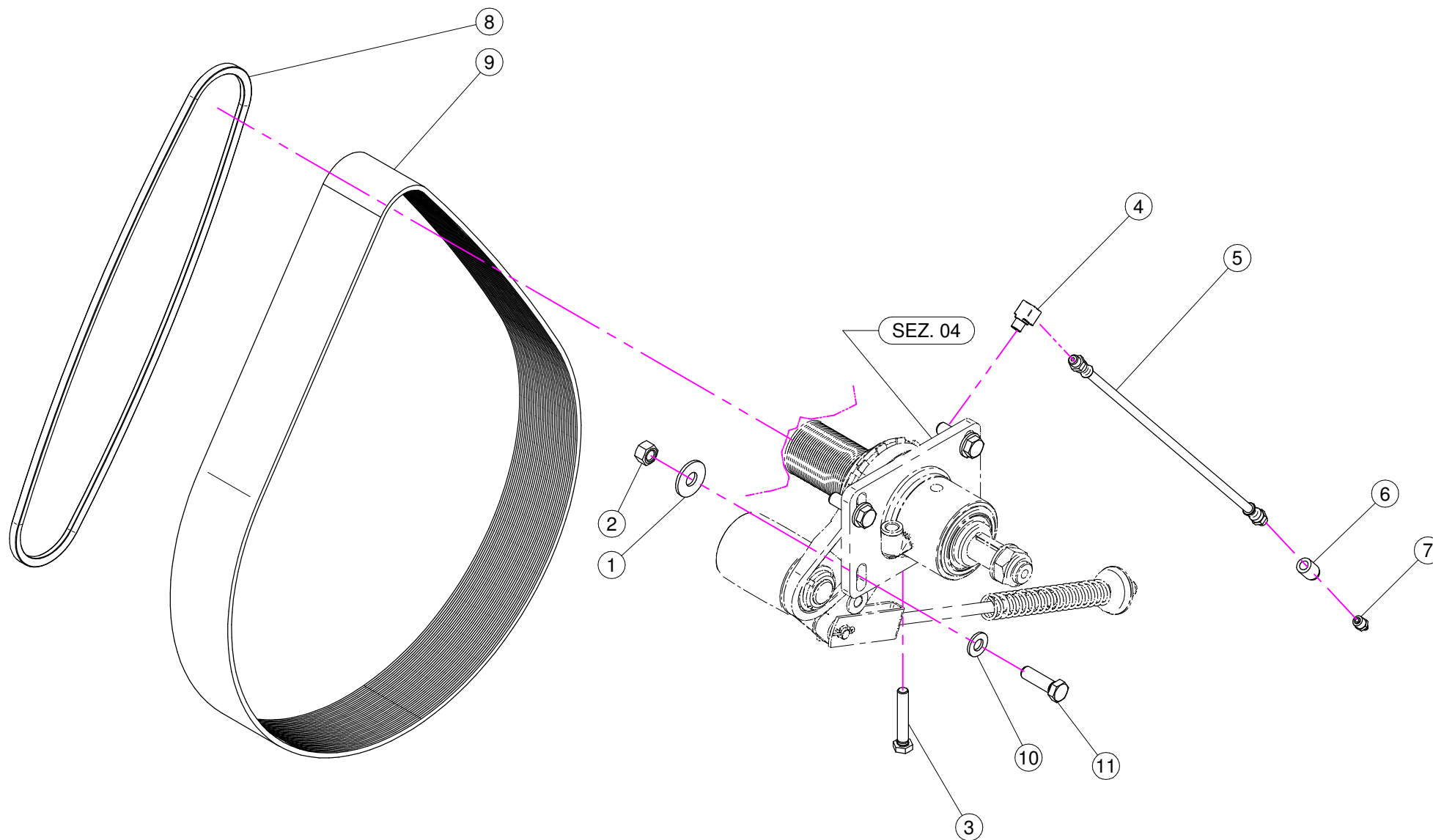

N°	Doc. Number	Titolo	Title	Q.tà	Note
1	XRP.012.036	RONDELLA PIANA D12 X 36	WASHER D12 X 36	4	
2	XD0.12.5587G	DADO M12 PG UNI 5587	M12 NUT	4	
3	XTE.010.060T	VITE TE M10 x 60	SCREW TE M10 x 60	1	
4	X02.736.000	RACCORDO INGRASSAGGIO 90 G. M10 X1	90 G. M10 X1 FITTING	1	
5	X02.738.040	PROLUNGA FLESSIBILE M10 x 1 L= 400	GREASER EXTENSION M10 x 1 L= 400	1	
6	X02.737.000	BOCCOLA PER INGRASSATORE	ACCESSORI	1	
7	XID.010.001	INGRASSATORE DIRITTO M10X1	GREASE NIPPLE	1	
8	XC0.500.03V	CINGHIA TRAPEZOIDALE	V - BELT	2	
9	XC0.650.J32	CINGHIA POLY-V	POLY-V BELT	1	
10	XRP.012.000	RONDELLA PIANA D. 12	WASHER D. 12	4	
11	XTE.012.040T	VITE TE M12X40 UNI 5739	BOLT TE M12X40	4	

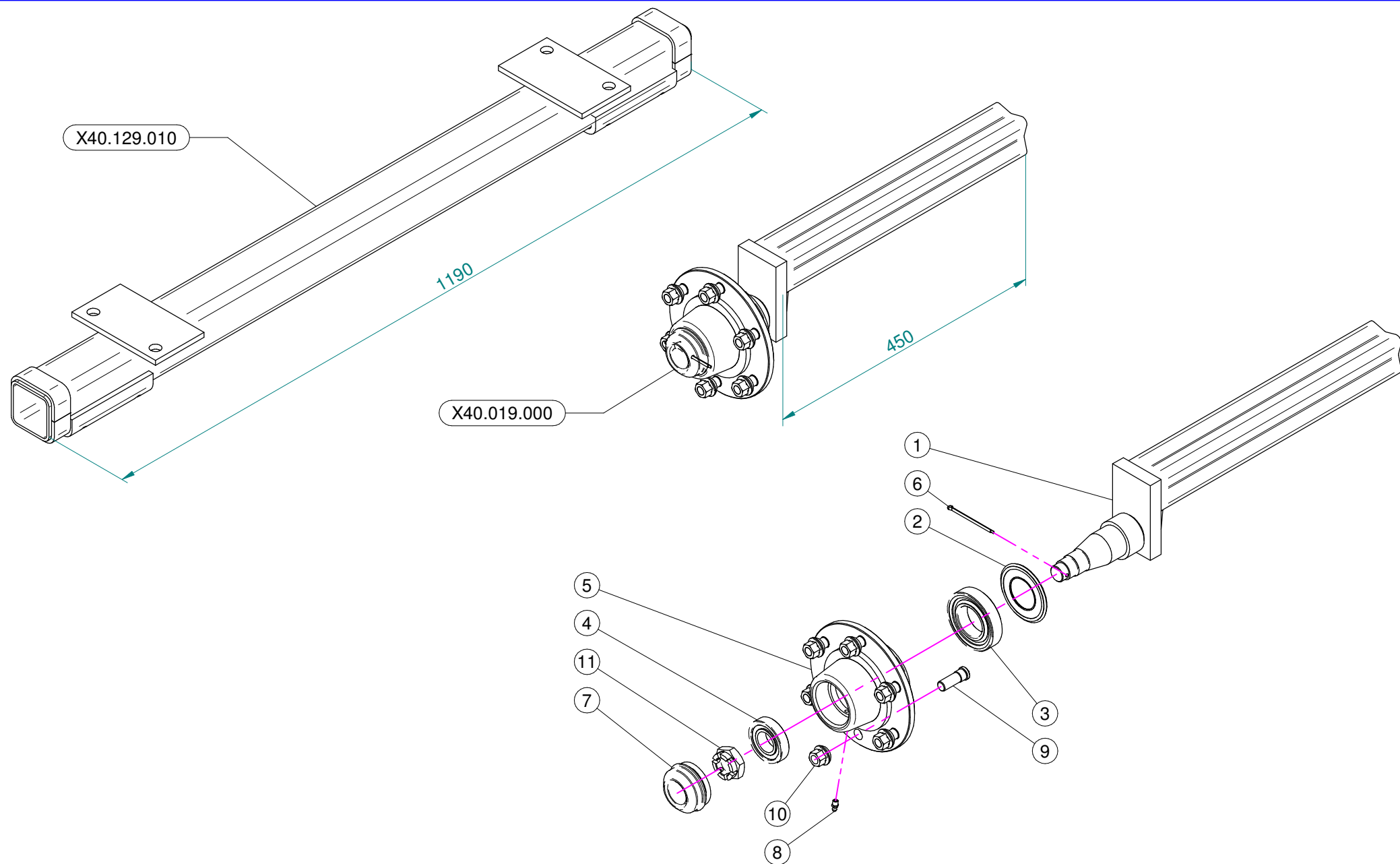

N°	Doc. Number	Titolo	Title	Q.tà	Note
1	X04.690.003	SEMIASSE A 5 COLONNETTE	AXLE SHAFT	1	N.D.
2	X20.258.000	PARA-OLIO 45x85 IN GOMMA	OIL COVER	1	
3	XK0.030.209	CUSCINETTO A UNA CORONA DI RULLI CONICI	BEARING	1	
4	XK0.030.206	CUSCINETTO A UNA CORONA DI RULLI CONICI	BEARING	1	
5	X05.903.001	MOZZI A 6 FORI GEARMORE	SIX HOLES FLANGE	1	N.D.
6	XCP.004.070I	COPIGLIA D. 4 Lg. 70	SPLIT PIN D. 4 Lg. 70	1	
7	X04.062.001	COPERCHIETTO DI CHIUSURA	COVER	1	
8	XID.006.001	INGRASSATORE DIRITTO M6	GREASER	1	
9	X05.911.001	COLONNETTA PER SEMIASSE M14x1.5	STUD	6	
10	X05.911.000	DADO PER COLONNETTA M14x1.5	SPECIAL NUT	6	
11	XDI.027.5594F	DADO ESAGONALE A 6 INTAGLI	SIX CASTLE NUT M27	1	

Gli esplosi elencati di seguito, sono relativi
a varianti od accessori a richiesta

Exploded drawings here listed, concern
variations or demanded accessories

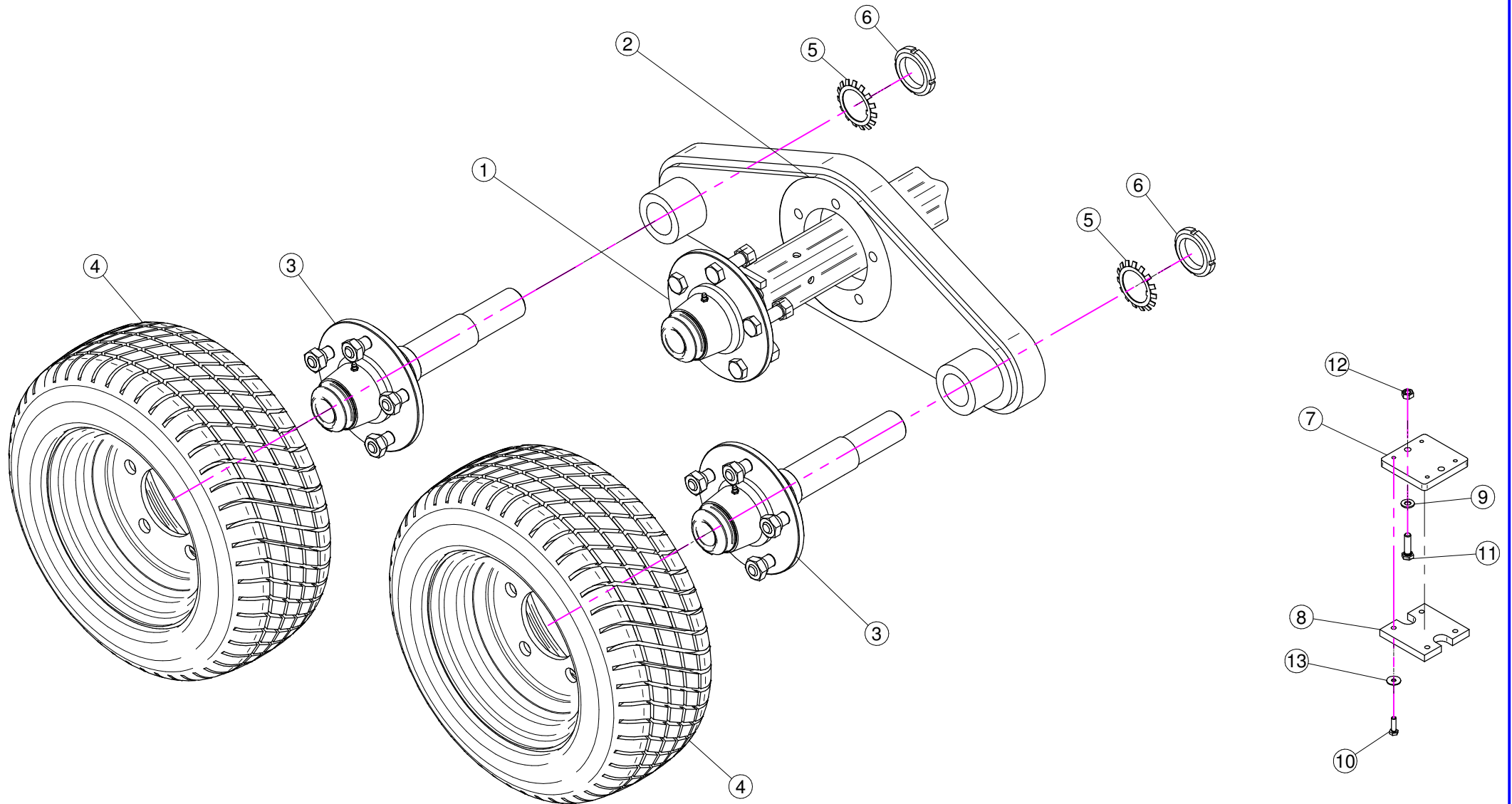

N°	Doc. Number	Titolo	Title	Q.tà	Note
1	X04.683.230	MOZZO A 5 COLONNETTE	WHEEL HUB	2	
2	X40.369.000	PIASTRA PORTA MOZZI RUOTE TANDEM	HUB SUPPORT SHEET	2	
3	X04.683.330	MOZZO A 5 COLONNETTE	WHEEL HUB	4	
4	X40.375.000	RUOTA 195/50 - 10 - 5Fori	TIRES	4	
5	XMB.009.000	ROSETTA DI SICUREZZA D.45	TOOTH LOCK WASHER	4	
6	XKM.009.000	GHIERA KM9	NUT KM9	4	
7	X40.373.001	SPESSORE FERMO RUOTE IN TANDEM	SPACER	4	
8	X40.374.001	SPESSORE IN GOMMA FERMO RUOTE IN TANDEM	SPACER	4	
9	XRP.008.000	RONDELLA PIANA D.8	WASHER D.8	16	
10	XTE.006.020T	VITE TE M6 x 20	SCREW TE M6 x 20	16	
11	XTE.008.030T	VITE TE M8x30	SCREW TE M8x30	8	
12	XD0.08.5588G	DADO M8 6S PG	M8 6S BIG LEAD NUT 5588	8	
13	XRP.006.018	RONDELLA PIANA D. 6x18	WASHER D.6x18	16	

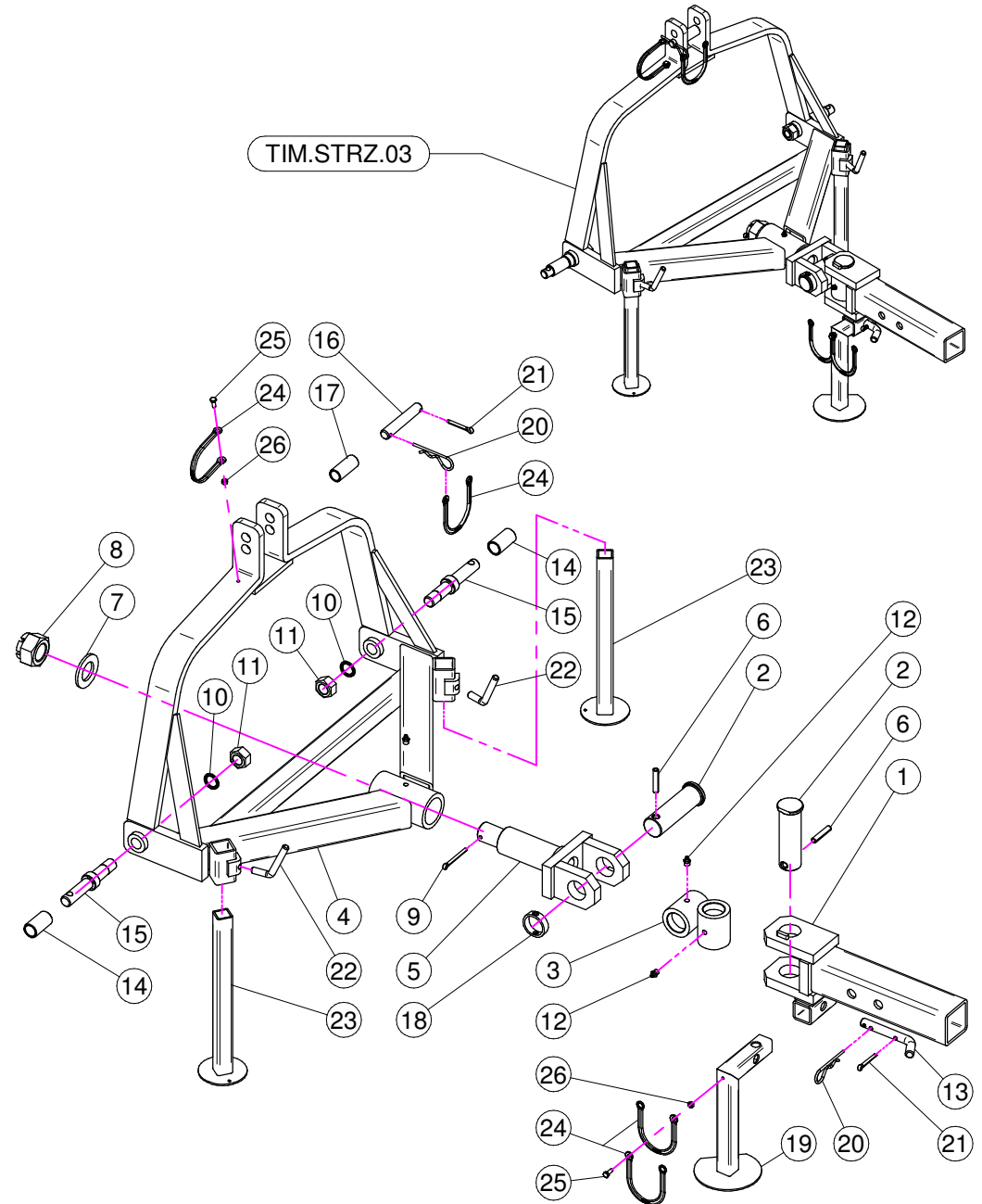
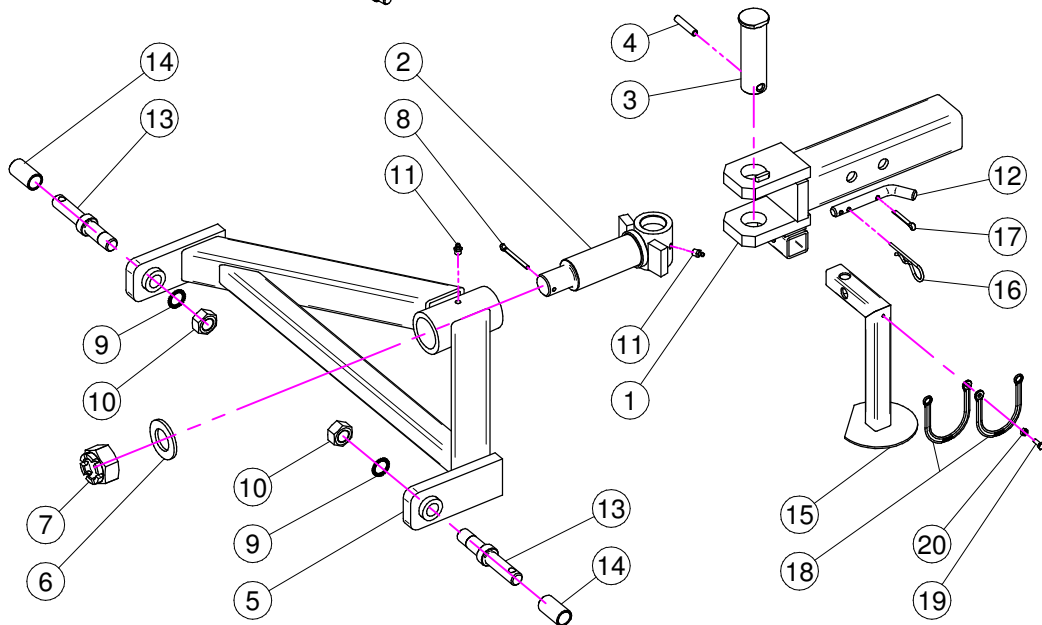
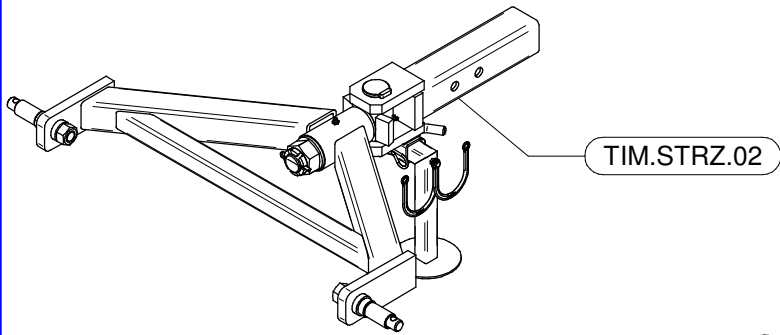
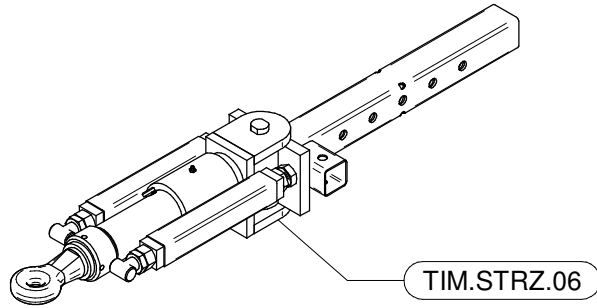

TIM.STRZ.02

N°	Doc. Number	Titolo	Title	Q.tà	Note
1	X40.153.001	TIMONE SNODATO - PARTICOLARE FISSO	DRAW-BAR - FIXING PARTICULAR	1	
2	X40.154.100	PERNO TIMONE STERZANTE A 2 PUNTI	PIN	1	
3	X40.150.000	PERNO PER TIMONE STERZANTE	PIN	1	
4	XSE.010.050	SPINA ELASTICA 10 x 50	SPRING PIN	1	
5	X40.152.000	CORPO A 2 PUNTI PER TIMONE STERZANTE	2 POINTS BODY	1	
6	XRP.036.000	RONDELLA PIANA Ø36	WASHER	1	
7	XDI.036.5593F	DADO AD INTAGLI M36	CASTLE NUT M30	1	
8	XCP.006.070	COPIGLIA	SPLIT PIN	1	
9	XRD.022.000	RONDELLA DENTELLATA D.22	TAB WASHER D.22	2	
10	XD0.22.5588F	DADO M22 x 1.5	NUT M22 x 1.5	2	
11	XID.010.001	INGRASSATORE DIRITTO M10X1	GREASE NIPPLE	2	
12	X20.505.000	SPINOTTO PIEDE D' APPOGGIO	PIN JACK STAND	1	
13	X04.064.100	SPINOTTO SOLLEVATORE	PIN POWER LIFT	2	
14	X40.202.000	BOCCOLA PER SPINOTTI SOLLEVATORE	BUSH	2	
15	X40.342.000	PIEDE D'APPOGGIO ESTRAIBILE	EXTRACTABLE JACK STAND	1	
16	X00.100.004	COPIGLIA D.4	SPLIT PIN D.4	1	
17	XCP.006.040I	COPIGLIA D.6 Lg.40	PIN D.6 Lg.40	1	
18	X21.183.000	STRISCIA FERMATAPPI	CAP STOP	2	
19	XTE.006.016T	VITE TE M6X16	SCREW TE M6X16	1	
20	XD0.06.5588G	DADO M6	NUT M6	1	

TIM.STRZ.03

N°	Doc. Number	Titolo	Title	Q.tà	Note
1	X40.153.001	TIMONE SNODATO - PARTICOLARE FISSO	DRAW-BAR - FIXING PARTICULAR	1	
2	X40.150.000	PERNO PER TIMONE STERZANTE	PIN	2	
3	X40.155.000	CROCERA PER TIMONE STERZANTE	JOINT	1	
4	X40.151.000	CORPO A 3 PUNTI PER TIMONE STERZANTE	3 POINTS BODY	1	
5	X40.154.000	PERNO PER TIMONE STERZANTE 3 PUNTI	PIN	1	
6	XSE.010.050	SPINA ELASTICA 10 x 50	SPRING PIN	2	
7	XRP.036.000	RONDELLA PIANA Ø36	WASHER	1	
8	XDI.036.5593F	DADO AD INTAGLI M36	CASTLE NUT M30	1	
9	XCP.006.070	COPIGLIA	SPLIT PIN	1	
10	XRD.022.000	RONDELLA DENTELLATA D.22	TAB WASHER D.22	2	
11	XD0.22.5588F	DADO M22 x 1.5	NUT M22 x 1.5	2	
12	XID.010.001	INGRASSATORE DIRITTO M10X1	GREASE NIPPLE	3	
13	X20.505.000	SPINOTTO PIEDE D' APPOGGIO	PIN JACK STAND	1	
14	X40.202.000	BOCCOLA PER SPINOTTI SOLLEVATORE	BUSH	2	
15	X04.064.100	SPINOTTO SOLLEVATORE	PIN POWER LIFT	2	
16	X04.076.000	SPINOTTO 3° PUNTO	PIN	1	
17	X20.778.000	BOCCOLA PER TERZO PUNTO PER PLUS	BUSH	1	
18	X40.363.000	DISTANZIALE	SPACER	1	
19	X40.342.000	PIEDE D'APPOGGIO ESTRAIBILE	EXTRACTABLE JACK STAND	1	
20	X00.100.004	COPIGLIA D.4	SPLIT PIN D.4	2	
21	XCP.006.040I	COPIGLIA D.6 Lg.40	PIN D.6 Lg.40	2	
22	X02.175.000	MANIGLIA DI BLOCCAGGIO	LOOKING HANDLE	2	
23	X40.251.200	PIEDE D'APPOGGIO	JACK	2	
24	X21.183.000	STRISCIA FERMATAPPI	CAP STOP	4	
25	XTE.006.016T	VITE TE M6X16	SCREW TE M6X16	2	
26	XD0.06.5588G	DADO M6	NUT M6	2	

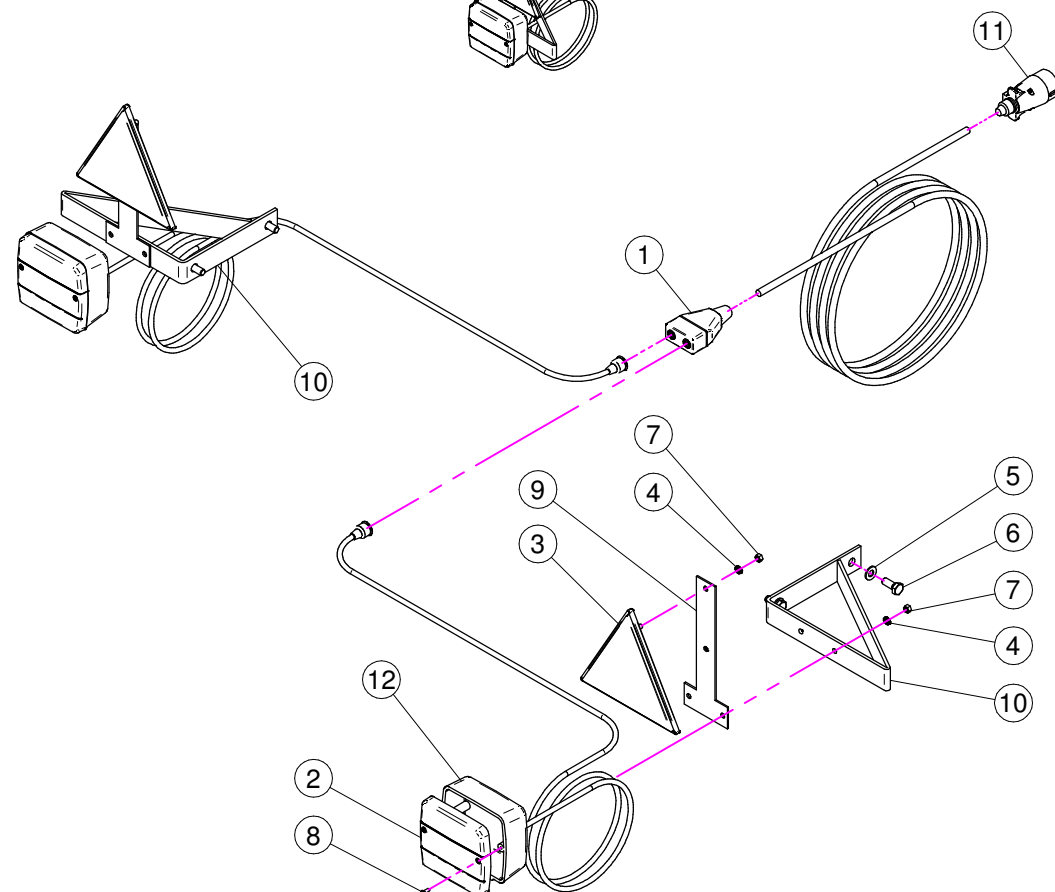
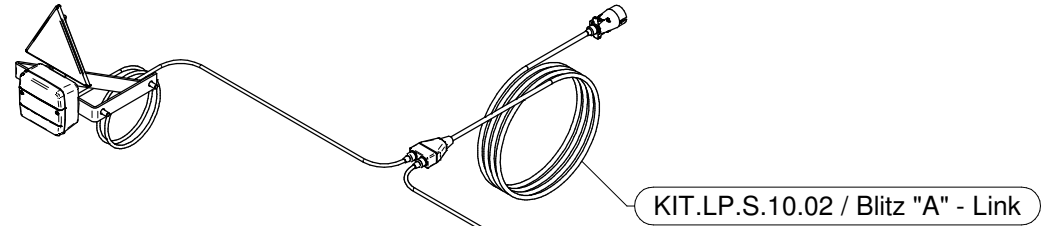
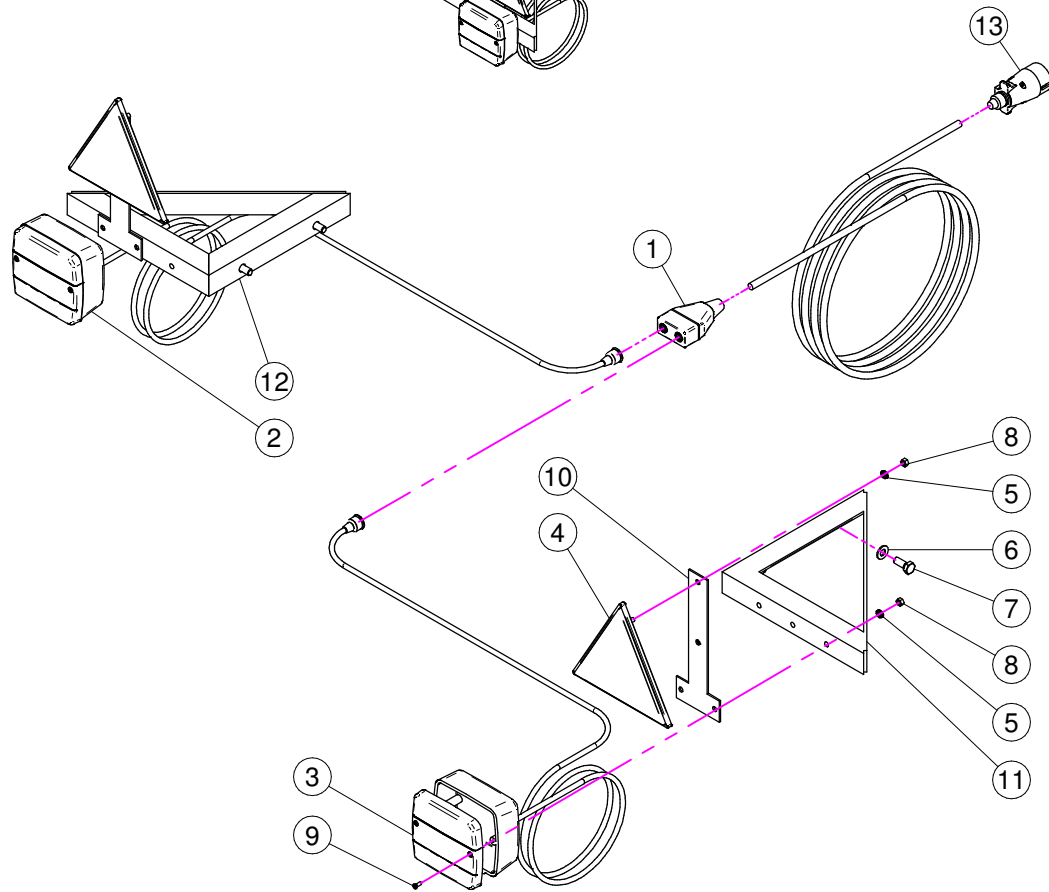
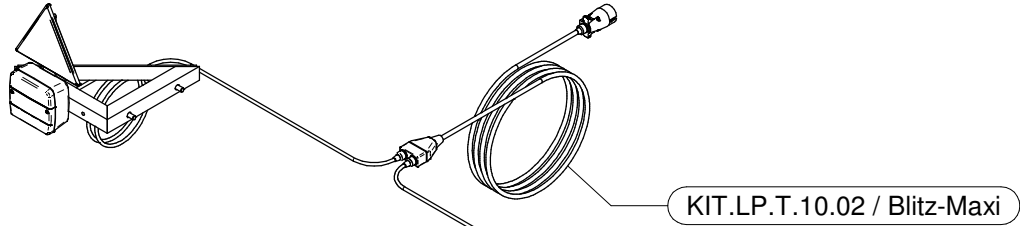

KIT.LP.T.10.02 (BLITZ-MAXI)

N°	Doc. Number	Titolo	Title	Q.tà	Note
1	X24.121.007	SCATOLA BLOCCO DIRAMAZIONI	ELECTRIC BOX	1	
2	X24.121.002	CORPO FANALE POSTERIORE 3F	BODY REAR LIGHT 3L	1	
3	X24.121.004	CATADIOTTRO FANALE POSTERIORE	REAR LIGHT REFLECTOR	2	
4	X24.121.001	CATADIOTTRO TRIANGOLARE	TRIANGULAR REFLECTOR	2	
5	XRD.005.000	RONDELLA DENTELLATA D.5	TAB WASHER D.5	8	
6	XRP.008.000	RONDELLA PIANA D.8	WASHER D.8	4	
7	XTE.008.020T	VITE TE 8x20	SCREW TE 8x20	4	
8	XD0.05.5587G	DADO M5 PG 5587	M5 PG 5587 NUT	8	
9	XTA.03,5.09,5I	VITE AUTOFILETTANTE D.3,5 x 9,5	SELF THREADING D.3,5 x 9,5	4	
10	X40.341.000	STAFFA	BRACKET	2	
11	X40.340.200	STAFFA DX	BRACKET DX	1	
12	X40.340.100	STAFFA SX	BRACKET SX	1	
13	X24.121.006	SPINA	PLUG	1	

KIT.LP.S.10.02 (BLITZ "A" - LINK)

N°	Doc. Number	Titolo	Title	Q.tà	Note
1	X24.121.007	SCATOLA BLOCCO DIRAMAZIONI	ELECTRIC BOX	1	
2	X24.121.004	CATADIOTTRO FANALE POSTERIORE	REAR LIGHT REFLECTOR	2	
3	X24.121.001	CATADIOTTRO TRIANGOLARE	TRIANGULAR REFLECTOR	2	
4	XRD.005.000	RONDELLA DENTELLATA D.5	TAB WASHER D.5	8	
5	XRP.008.000	RONDELLA PIANA D.8	WASHER D.8	4	
6	XTE.008.020T	VITE TE 8x20	SCREW TE 8x20	4	
7	XD0.05.5587G	DADO M5 PG 5587	M5 PG 5587 NUT	8	
8	XTA.03,5.09,5I	VITE AUTOFILETTANTE D.3,5 x 9,5	SELF THREADING D.3,5 x 9,5	4	
9	X40.341.000	STAFFA	BRACKET	2	
10	X40.340.000	STAFFA	BRACKET	2	
11	X24.121.006	SPINA	PLUG	1	
12	X24.121.002	CORPO FANALE POSTERIORE 3F	BODY REAR LIGHT 3L	1	

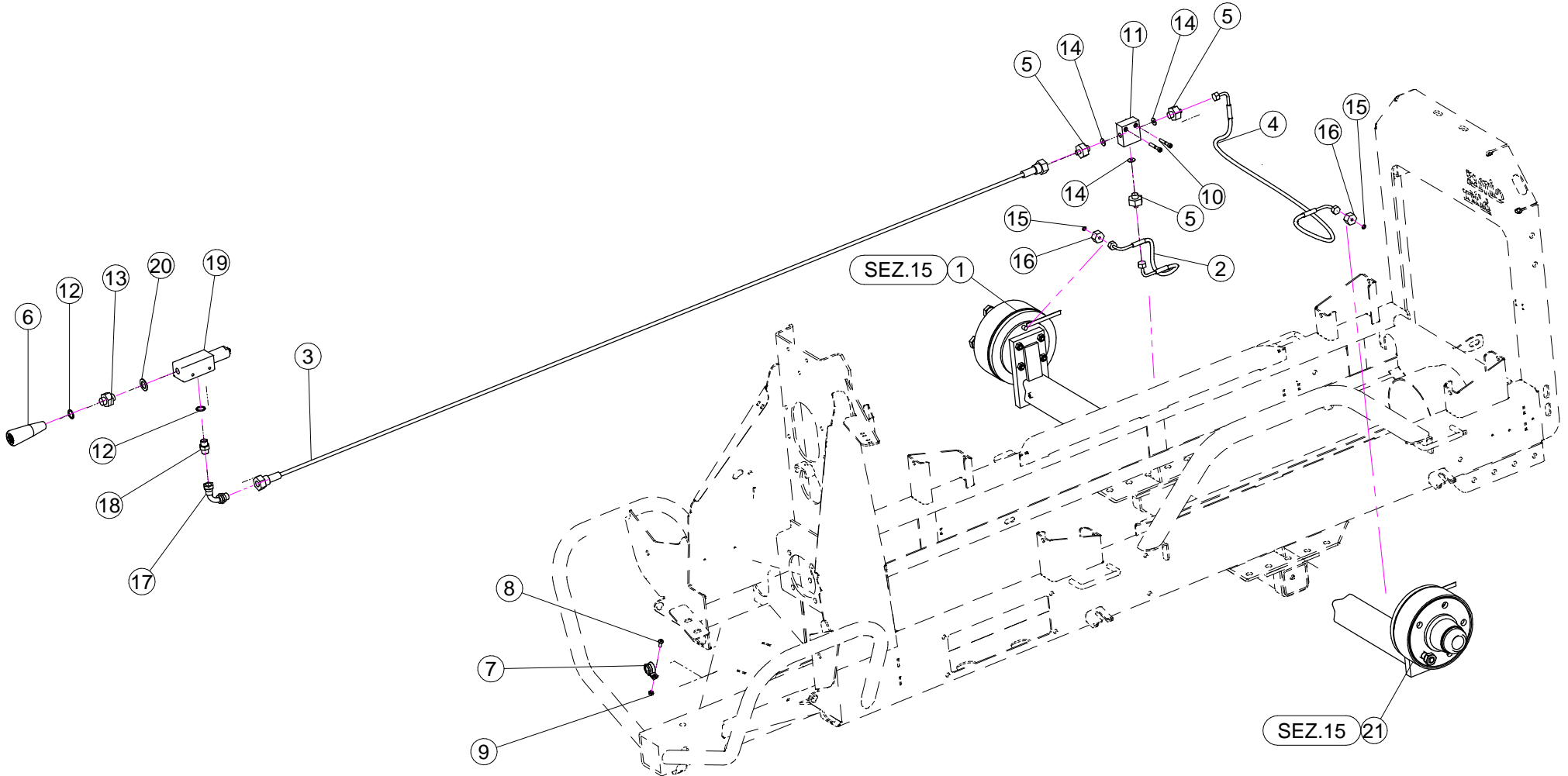

N°	Doc. Number	Titolo	Title	Q.tà
1	X04.683.500	SEMIASSE A 5 COLONNETTE CON FRENO MONTATO SU BLITZ	WHEEL HUB	1
2	X21.341.060	TUBO OLIO 1/4" L=600 CON RACCORDI	OIL HOSE 1/4" L=600 WITH FITTINGS	1
3	X21.341.350	TUBO OLIO 1/4" L=3500 CON RACCORDI	OIL HOSE 1/4" L=3500 WITH FITTINGS	1
4	X21.341.100	TUBO OLIO 1/4" L=1000 CON RACCORDI	OIL HOSE 1/4" L=1000 WITH FITTINGS	1
5	X21.342.000	NIPPLO DOPPIO 1/4" 1/4"	DOUBLE NIPLES 1/4" 1/4"	3
6	X21.343.000	INNESTO FASTER	CLUTCH	1
7	XFG.018.000	FASCETTA GOMMATA PER TUBI D.18	STICKER	1
8	XTCC.06.16	VITE TESTA A CROCE M6x16	CROSS SLOTTED SCREW M6x16	1
9	XDOT.06.5587	DADO OTTONE M6	M6 BRASS NUT 5587	1
10	XTCE.006 .040	VITE BRUGOLA TCE M6x40	BOLT TCE M6x40	2
11	X21.348.000	DISTRIBUTORE OLIO PER FRENO	BRAKE OIL DISTRIBUTOR	1
12	X21.344.000	RONDELLA RAME D.18x1,5	COPPER WASHER D.18x1,5	2
13	X21.345.000	NIPPLO RIDOTTO 3/8 - m18	NIPLES 3/8 - M18	1
14	X21.349.000	RONDELLA RAME D.1/4	COPPER WASHER D.1/4	3
15	X21.346.000	RONDELLA RAME D.10x1,5	COPPER WASHER D.10x1,5	2
16	X21.347.000	RACCORDO RAD 1803	RAD 1803 FITTING	2
17	X21.381.000	CURVA PER OLIO 3/8 M - 3/8 F	OIL BEND 3/8 M - 3/8 F	1
18	X21.107.000	NIPPLO 3/8M - 3/8M	NIPLES 3/8M - 3/8M	1
19	X21.382.000	VALVOLA MASSIMA PRESSIONE OLIO 60 bar	MAXIMUM PRESSURE OIL VALVE 60 bar	1
20	X21.362.000	RONDELLA RAME D.30x18x1,5	COPPER WASHER D.30x18x1,5	1
21	X04.683.700	SEMIASSE A 5 COLONNETTE CON FRENO	WHEEL HUB	1

SEMIASSE SINISTRO

X04.683.700

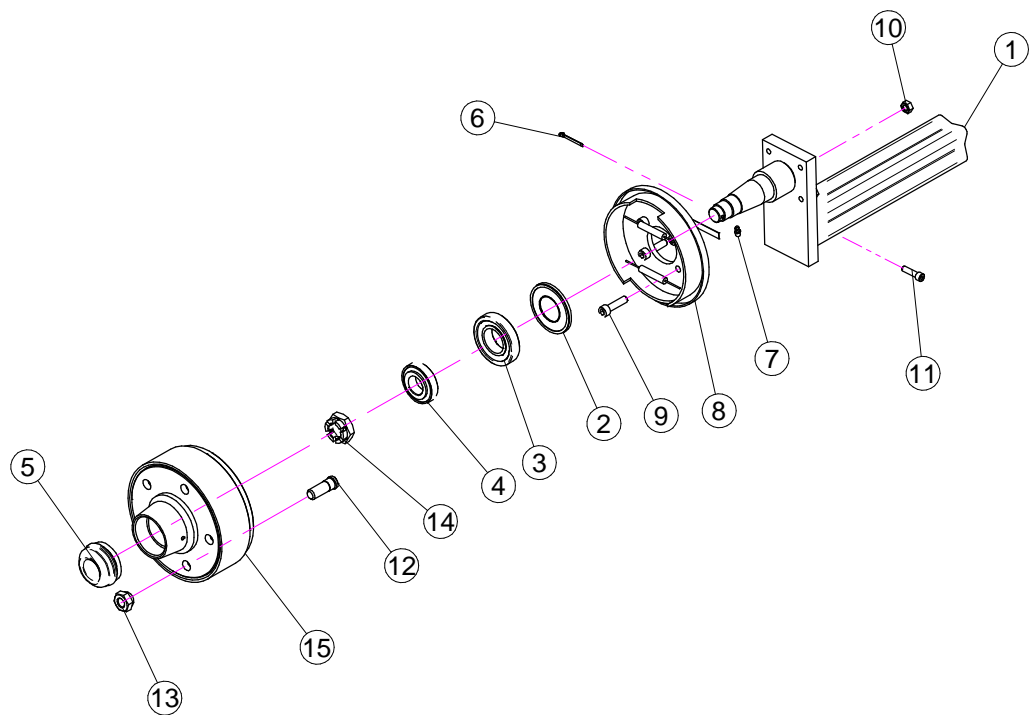
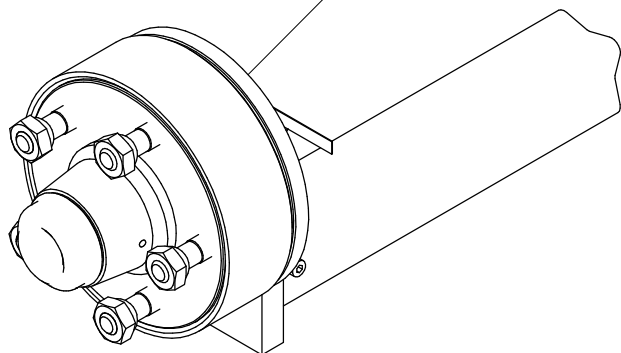

SEMIASSE DESTRO

X04.683.500

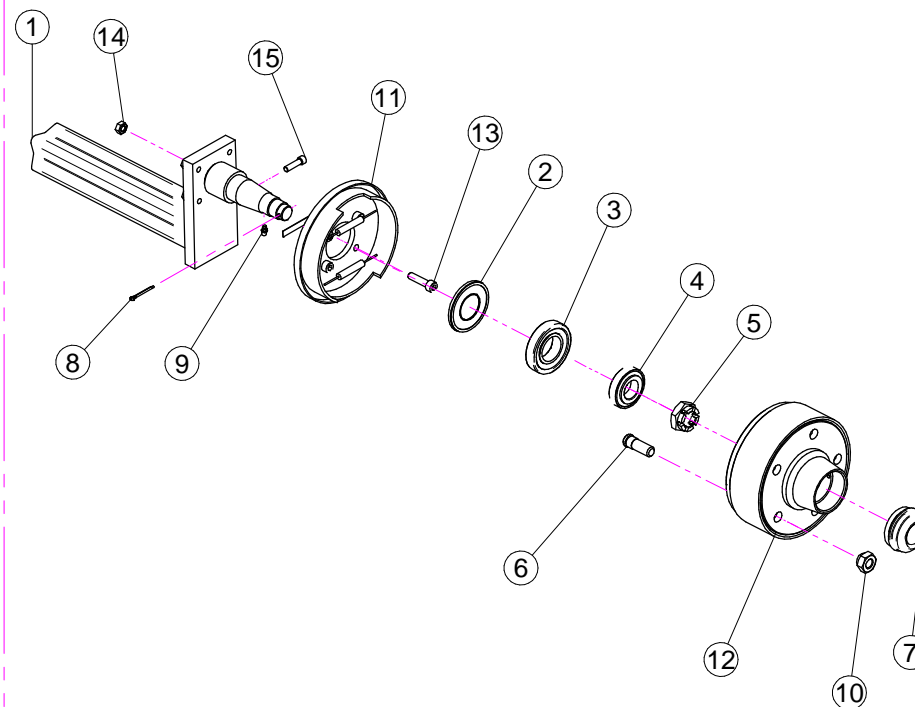
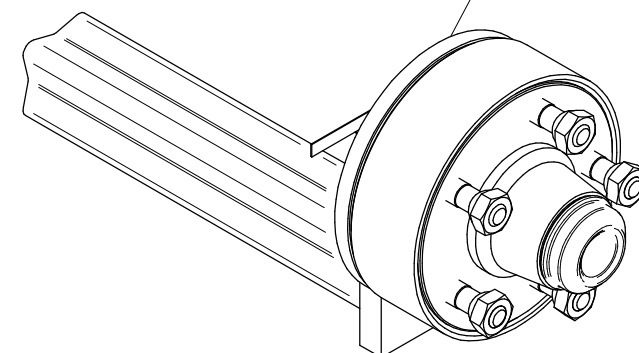

X04.683.700

X04.683.500

N°	Doc. Number	Titolo	Title	Q.tà
1	X04.683.501	SEMIASSE A 5 COLONNETTE ALLUNGATO PER FRENO	AXLE SHAFT	1
2	X20.257.000	PARA - POLVERE D. 40x80 IN GOMMA	DUST SHIELDER	1
3	XK0.030.208	CUSCINETTO A UNA CORONA DI RULLI CONICI	BEARING	1
4	XK0.030.206	CUSCINETTO A UNA CORONA DI RULLI CONICI 30206	BEARING	1
5	X04.062.001	COPERCHIETTO DI CHIUSURA	COVER	1
6	X20.259.000	COPIGLIA D.4 L=45 PER MOZZI	SPLIT PIN	1
7	XID.006.001	INGRASSATORE DIRITTO M6	GREASER	1
8	X40.388.000	FRENO SX COMPLETO	LEFT BRAKE	1
9	XTCE.010.040	VITE TESTA CIL. CON ESAGONO INCASSATO	HEXAGON SOCKET HEAD SCREW M10 x 40	1
10	XD0.10.5588G	DADO M 10 6S PG	M10 6S BIG LEAD NUT 5588	1
11	XTCE.008.030	VITE BRUGOLA TCE M8x30	BOLT TCE M8x30	1
12	X04.681.000	COLONNETTA PER SEMIASSE M16x1,5	STUD M16x1,5	1
13	X04.682.000	DADO PER COLONNETTA M 16x1.5	SPECIAL NUT	1
14	XDI.027.5594F	DADO ESAGONALE A 6 INTAGLI	SIX CASTLE NUT M27	1
15	X04.200.100	TAMBURO PER FRENO	BRAKE DRUM	1

N°	Doc. Number	Titolo	Title	Q.tà
1	X04.683.501	SEMIASSE A 5 COLONNETTE ALLUNGATO PER FRENO	AXLE SHAFT	1
2	X20.257.000	PARA - POLVERE D. 40x80 IN GOMMA	DUST SHIELDER	1
3	XK0.030.208	CUSCINETTO A UNA CORONA DI RULLI CONICI	BEARING	1
4	XK0.030.206	CUSCINETTO A UNA CORONA DI RULLI CONICI 30206	BEARING	1
5	XDI.027.5594F	DADO ESAGONALE A 6 INTAGLI	SIX CASTLE NUT M27	1
6	X04.681.000	COLONNETTA PER SEMIASSE M16x1,5	STUD M16x1,5	5
7	X04.062.001	COPERCHIETTO DI CHIUSURA	COVER	1
8	X20.259.000	COPIGLIA D.4 L=45 PER MOZZI	SPLIT PIN	1
9	XID.006.001	INGRASSATORE DIRITTO M6	GREASER	1
10	X04.682.000	DADO PER COLONNETTA M 16x1.5	SPECIAL NUT	5
11	X40.389.000	FRENO DX COMPLETO	RIGHT BRAKE	1
12	X04.200.100	TAMBURO PER FRENO	BRAKE DRUM	1
13	XTCE.010.040	VITE TESTA CIL. CON ESAGONO INCASSATO	HEXAGON SOCKET HEAD SCREW M10 x 40	4
14	XD0.10.5588G	DADO M 10 6S PG	M10 6S BIG LEAD NUT 5588	4
15	XTCE.008.030	VITE BRUGOLA TCE M8x30	BOLT TCE M8x30	1

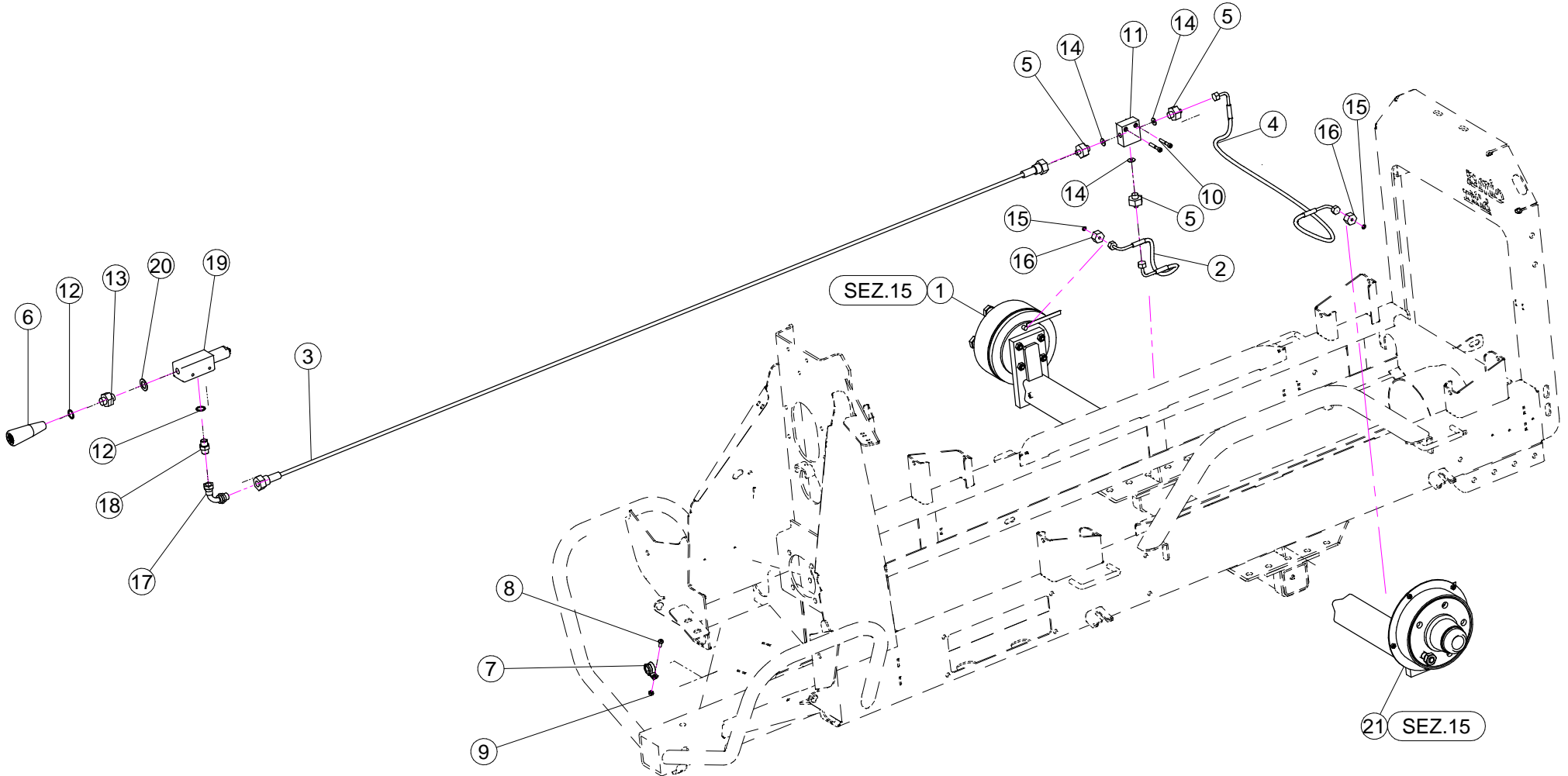

N°	Doc. Number	Titolo	Title	Q.tà
1	X04.683.500	SEMIASSE A 5 COLONNETTE CON FRENO MONTATO SU BLITZ	WHEEL HUB	1
2	X21.341.060	TUBO OLIO 1/4" L=600 CON RACCORDI	OIL HOSE 1/4" L=600 WITH FITTINGS	1
3	X21.341.350	TUBO OLIO 1/4" L=3500 CON RACCORDI	OIL HOSE 1/4" L=3500 WITH FITTINGS	1
4	X21.341.100	TUBO OLIO 1/4" L=1000 CON RACCORDI	OIL HOSE 1/4" L=1000 WITH FITTINGS	1
5	X21.342.000	NIPPLO DOPPIO 1/4" 1/4"	DOUBLE NIPLES 1/4" 1/4"	3
6	X21.343.000	INNESTO FASTER	CLUTCH	1
7	XFG.018.000	FASCETTA GOMMATA PER TUBI D.18	STICKER	1
8	XTCC.06.16	VITE TESTA A CROCE M6x16	CROSS SLOTTED SCREW M6x16	1
9	XDOT.06.5587	DADO OTTONE M6	M6 BRASS NUT 5587	1
10	XTCE.006 .040	VITE BRUGOLA TCE M6x40	BOLT TCE M6x40	2
11	X21.348.000	DISTRIBUTORE OLIO PER FRENO	BRAKE OIL DISTRIBUTOR	1
12	X21.344.000	RONDELLA RAME D.18x1,5	COPPER WASHER D.18x1,5	2
13	X21.345.000	NIPPLO RIDOTTO 3/8 - m18	NIPLES 3/8 - M18	1
14	X21.349.000	RONDELLA RAME D.1/4	COPPER WASHER D.1/4	3
15	X21.346.000	RONDELLA RAME D.10x1,5	COPPER WASHER D.10x1,5	2
16	X21.347.000	RACCORDO RAD 1803	RAD 1803 FITTING	2
17	X21.381.000	CURVA PER OLIO 3/8 M - 3/8 F	OIL BEND 3/8 M - 3/8 F	1
18	X21.107.000	NIPPLO 3/8M - 3/8M	NIPLES 3/8M - 3/8M	1
19	X21.382.000	VALVOLA MASSIMA PRESSIONE OLIO 60 bar	MAXIMUM PRESSURE OIL VALVE 60 bar	1
20	X21.362.000	RONDELLA RAME D.30x18x1,5	COPPER WASHER D.30x18x1,5	1
21	X04.683.400	SEMIASSE A 5 COLONNETTE CON FRENO	WHEEL HUB	1

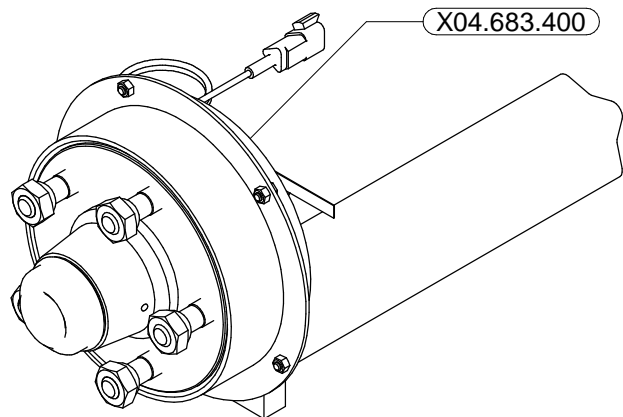

SEMIASSE SINISTRO

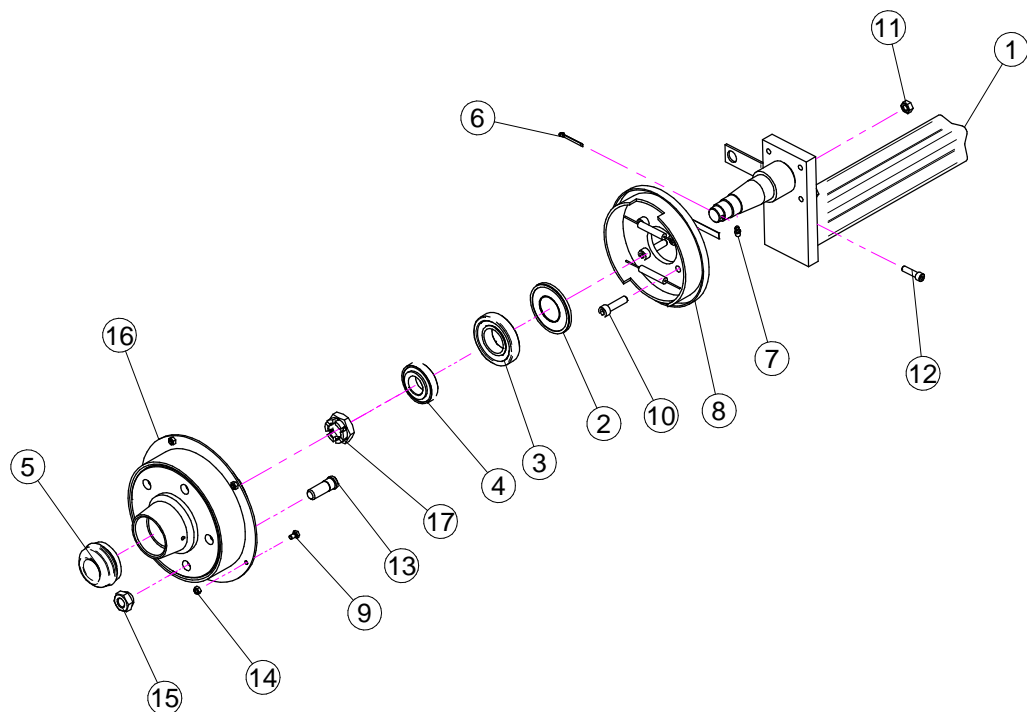

SEMIASSE DESTRO

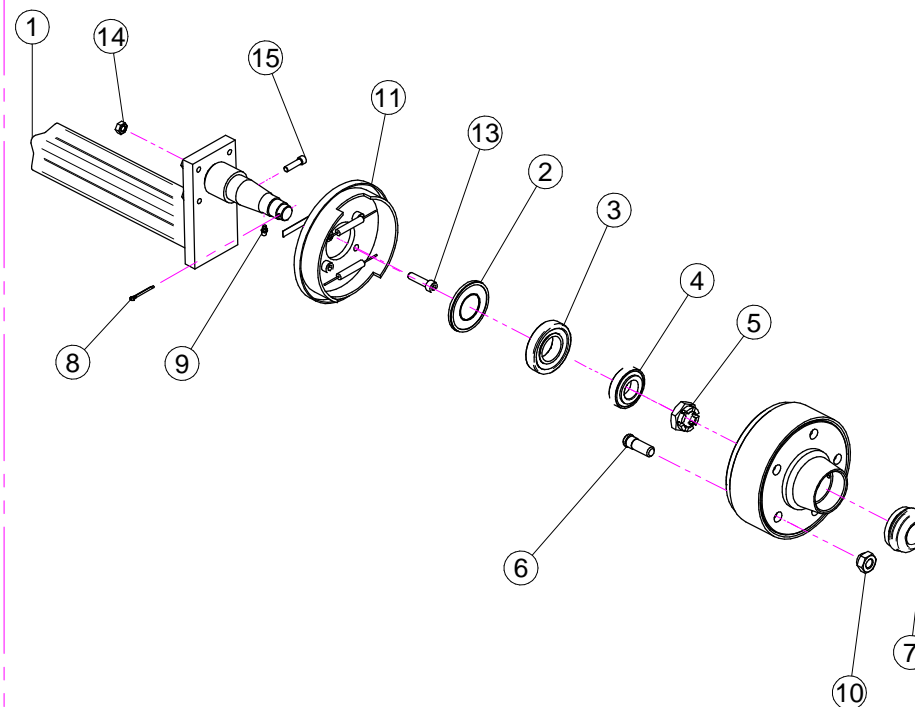
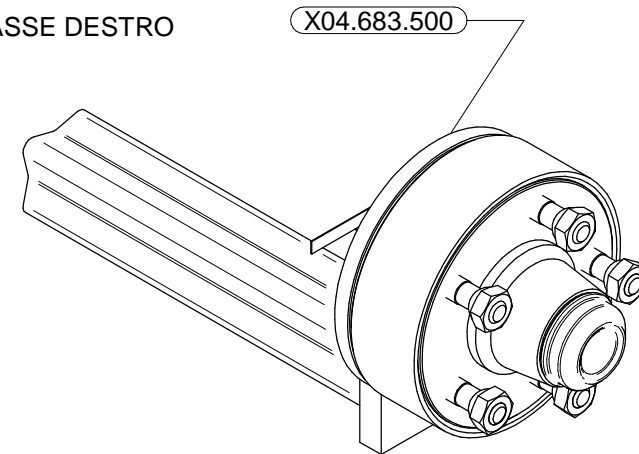

X04.683.400

X04.683.500

N°	Doc. Number	Titolo	Title	Q.tà
1	X04.683.401	SEMIASSE A 5 COLONNETTE ALLUNGATO PER FRENO ED EPA	AXLE SHAFT	1
2	X20.257.000	PARA - POLVERE D. 40x80 IN GOMMA	DUST SHIELDER	1
3	XK0.030.208	CUSCINETTO A UNA CORONA DI RULLI CONICI	BEARING	1
4	XK0.030.206	CUSCINETTO A UNA CORONA DI RULLI CONICI 30206	BEARING	1
5	X04.062.001	COPERCHIETTO DI CHIUSURA	COVER	1
6	X20.259.000	COPIGLIA D.4 L=45 PER MOZZI	SPLIT PIN	1
7	XID.006.001	INGRASSATORE DIRITTO M6	GREASER	1
8	X40.388.000	FRENO SX COMPLETO	LEFT BRAKE	1
9	XTE.006.010T	VITE TE M6x10	SCREW TE M6x10	1
10	XTCE.010.040	VITE TESTA CIL. CON ESAGONO INCASSATO	HEXAGON SOCKET HEAD SCREW M10 x 40	1
11	XD0.10.5588G	DADO M 10 6S PG	M10 6S BIG LEAD NUT 5588	1
12	XTCE.008.030	VITE BRUGOLA TCE M8x30	BOLT TCE M8x30	1
13	X04.681.000	COLONNETTA PER SEMIASSE M16x1,5	STUD M16x1,5	1
14	XD0.06.5588G	DADO M6	NUT M6	1
15	X04.682.000	DADO PER COLONNETTA M 16x1.5	SPECIAL NUT	1
16	X04.200.000	TAMBURO PER FRENO E EPA	BRAKE DRUM	1
17	XDI.027.5594F	DADO ESAGONALE A 6 INTAGLI	SIX CASTLE NUT M27	1

N°	Doc. Number	Titolo	Title	Q.tà
1	X04.683.501	SEMIASSE A 5 COLONNETTE ALLUNGATO PER FRENO	AXLE SHAFT	1
2	X20.257.000	PARA - POLVERE D. 40x80 IN GOMMA	DUST SHIELDER	1
3	XK0.030.208	CUSCINETTO A UNA CORONA DI RULLI CONICI	BEARING	1
4	XK0.030.206	CUSCINETTO A UNA CORONA DI RULLI CONICI 30206	BEARING	1
5	XDI.027.5594F	DADO ESAGONALE A 6 INTAGLI	SIX CASTLE NUT M27	1
6	X04.681.000	COLONNETTA PER SEMIASSE M16x1,5	STUD M16x1,5	5
7	X04.062.001	COPERCHIETTO DI CHIUSURA	COVER	1
8	X20.259.000	COPIGLIA D.4 L=45 PER MOZZI	SPLIT PIN	1
9	XID.006.001	INGRASSATORE DIRITTO M6	GREASER	1
10	X04.682.000	DADO PER COLONNETTA M 16x1.5	SPECIAL NUT	5
11	X40.389.000	FRENO DX COMPLETO	RIGHT BRAKE	1
12*	X04.200.100	TAMBURO PER FRENO	BRAKE DRUM	1
13	XTCE.010.040	VITE TESTA CIL. CON ESAGONO INCASSATO	HEXAGON SOCKET HEAD SCREW M10 x 40	4
14	XD0.10.5588G	DADO M 10 6S PG	M10 6S BIG LEAD NUT 5588	4
15	XTCE.008.030	VITE BRUGOLA TCE M8x30	BOLT TCE M8x30	1

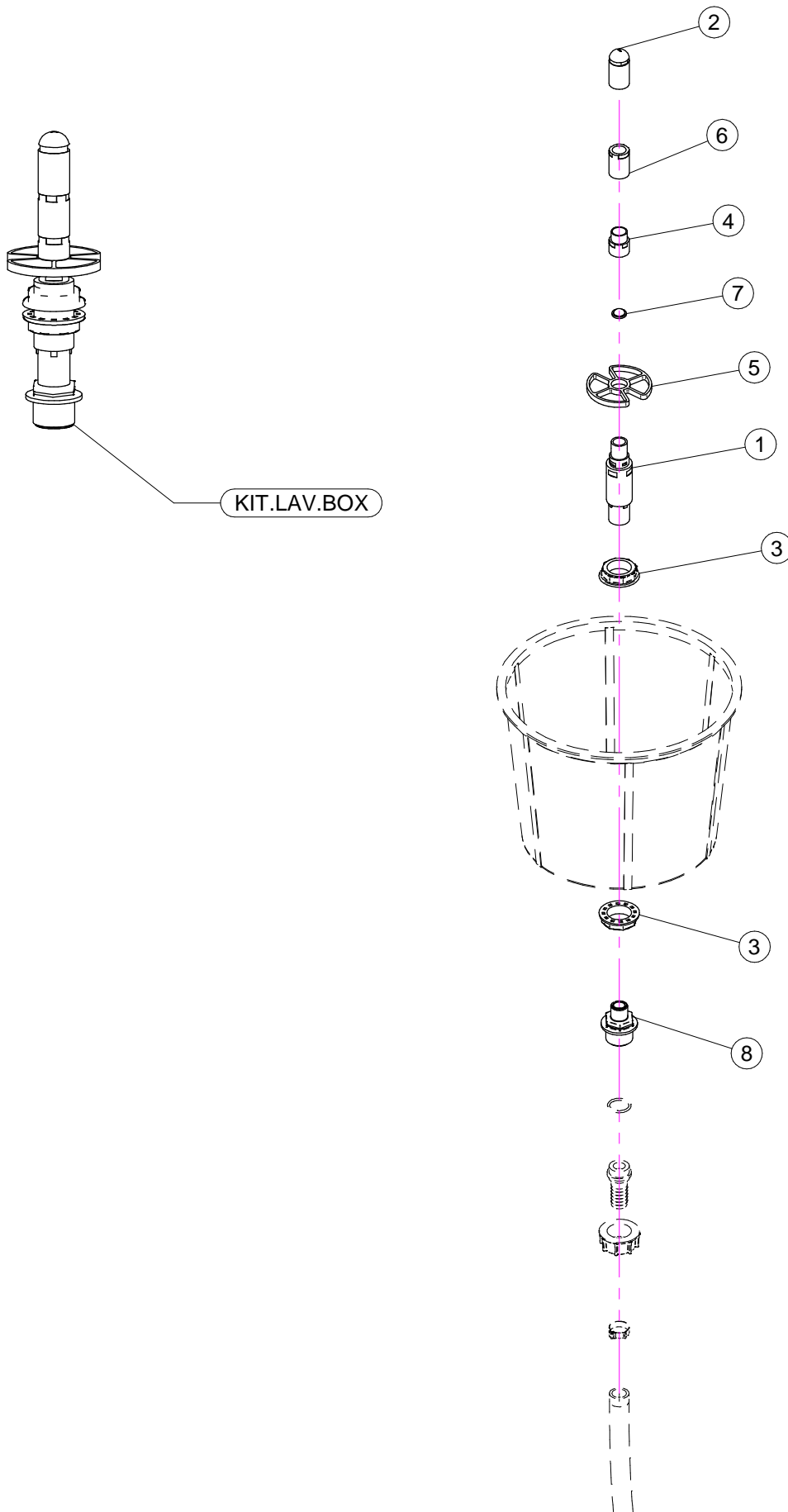

N°	Doc. Number	Titolo	Title	Q.tà	Note
1	X21.190.000	VALVOLA PER TESTINA LAVAGGIO CONTENITORI	VALVE FOR BOX WASH HEAD	1	
2	X21.191.000	TESTINA PER LAVAGGIO CONTENITORI	HEAD FOR BOX WASH	1	
3	X00.542.000	GHIERA 1"	NUT 1"	2	
4	X21.414.000	PORTAFILTRO	FILTER RING	1	
5	X21.411.000	FERMO BARATTOLO	BOX BLOCK	1	
6	X21.412.000	PORTA TESTINA PER LAVAGGIO CONTENITORI	HEAD BASE FOR BOX WASH	1	
7	X21.413.000	FILTRO PER LAVABARATTOLO	FILTER	1	
8	X21.410.000	NIPPLO 1/2M - 1M	NIPPLE 1/2M - 1M	1	