

(⌘) A richiesta / Optional Devices

Sez. 23 (a)
Timone Sterzante
Steering Drawbar

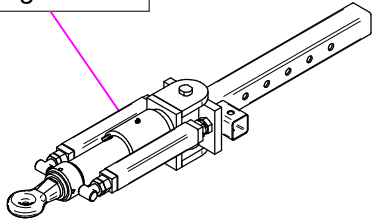

Sez. 23 (a)
Timone Sterzante a 3 punti
Steering Drawbar 3 points

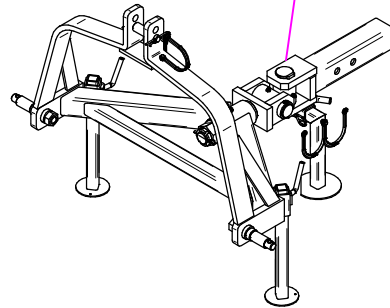

Sez. 23 (a)
Timone Sterzante a 2 punti
Steering Drawbar 2 points

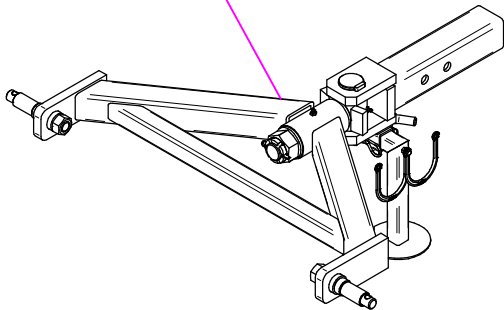

Sez.06E (a)
Elettrovalvola Regolazione Pressione
Solenoid Valves Regulation Pressure

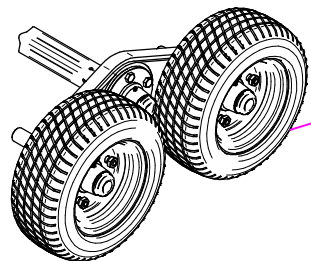
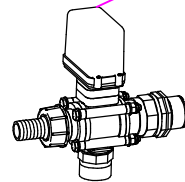

Sez.14 (a)
Ruote in Tandem
Tandem Wheels

(a) A richiesta / Optional Devices

Sez.22 (a)
Tubazione Riempimento
Filling pipe

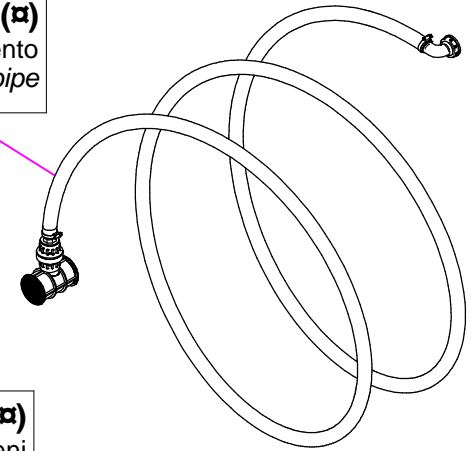

Sez.15A (a)
Freni
Brakes

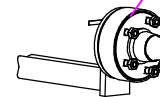

Sez.02E (a)
Kit Lava barattoli
Container Washing
Device Kit

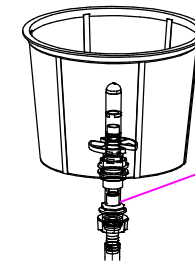

Sez. 26 (a)
Kit Luci
Kit lights

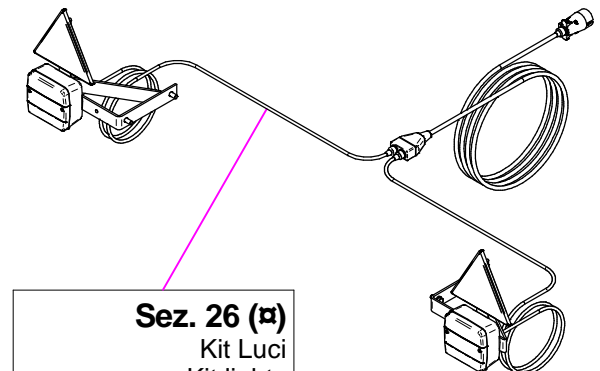

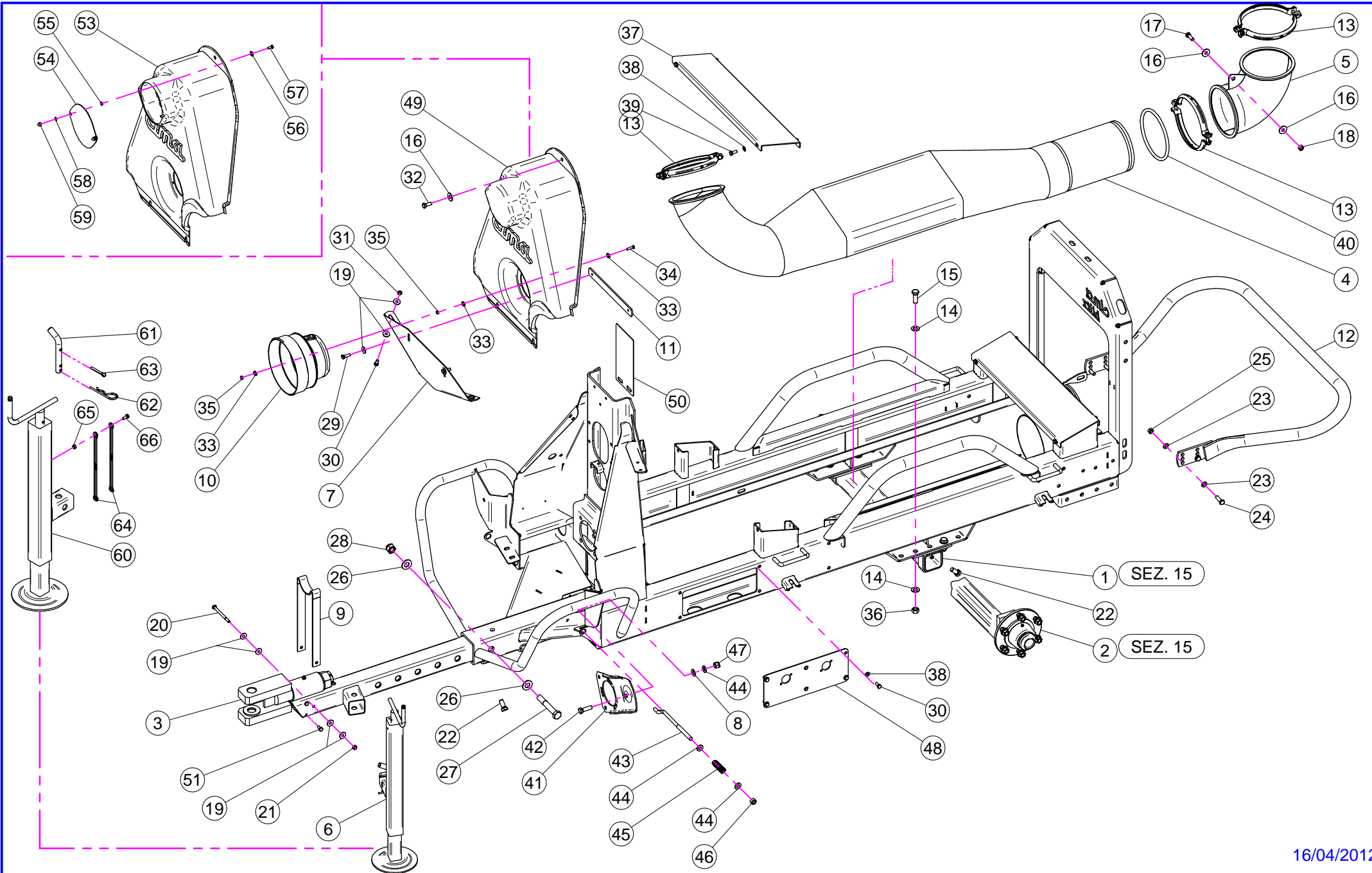

N°	Doc. Number	Titolo	Title	Q.tà	Note
1	X40.126.000	ASSALE	AXLE	1	
2	X40.020.150	ASSIEME MOZZO 6 COLONNETTE	HUB 6 COLONNETTE	2	
3	X40.136.200	TIMONE "TIPO USA"	DRAW-BAR "TIPO USA"	1	
4	X40.141.100	TUNNEL PASSAGGIO ARIA BLITZ	AIR WAY TUNNEL	1	
5	X05.615.000	CURVA D.175 90°	ELBOW D.175 90°	1	
6	X04.993.070C	PIEDE D'APPOGGIO ESTRAIBILE	EXTRACTABLE JACK STAND	1	
7	X20.531.000	LAMIERA FISSAGGIO CARTER	CARTER FIXING PLATE	1	
8	XMT.012.000	MOLLA A TAZZA D. 12	WASHER D.12	1	
9	X20.409.000	SUPPORTO PER CARDANO	SHAFT SUPPORT	1	
10	X02.440.000	CONTROCUFFIA D.210 PER CARDANO	SHAFT CONE D.210	1	
11	X20.532.000	PIATTO BLOCCAGGIO CARTER	FRONT HOUSING BLOCKING PLATE	1	
12	X40.000.000	CERCHIO DI PROTEZIONE	BUMPER	1	
13	X05.616.000	COLLARE PER TUBI D.175	PIPE CLAMP D.175	3	
14	XRP.014.000	RONDELLA PIANA D.14	WASHER D.14	8	
15	XTE.014.040T	VITE TE M14 x 40	SCREW TE M14 x 40	4	
16	XRP.010.030	RONDELLA PIANA D.10 x 30 mm	WASHER D.10 x 30 mm	3	
17	XTE.010.030T	VITE TE M10 x 30	SCREW TE M10 x 30	1	
18	XD0.10.5587G	DADO M10	NUT M10	1	
19	XRP.008.024	RONDELLA PIANA LARGA D.8X24	WASHER D.8X24	10	
20	XTE.008.100	VITE TE M8 x 100	SCREW TE M8 x 100	1	
21	XDA.008.0AG	DADO AUTOBLOCCANTE M8	SELF LOCKING NUT M8	1	
22	XTE.014.030T	VITE TE M14x30	SCREW TE M14x30	6	
23	XRP.010.000	RONDELLA PIANA D.10	WASHER D.10	8	
24	XTE.010.035T	VITE TE 10 x 35	SCREW TE 10 x 35	4	
25	XD0.10.5587G	DADO M10	NUT M10	4	
26	XRP.018.000	RONDELLA PIANA D.18	WASHER	2	
27	XTE.018.120	VITE TE M18 x 120	SCREW TE M18 x 120	1	
28	XDA.018.0AG	DADO AUTOBLOCCANTE M18x2.5	SELF LOCKING NUT M18	1	
29	XTE.008.025T	VITE TE M8 x 25	SCREW TE M8 x 25	2	
30	XTE.008.020T	VITE TE 8x20	SCREW TE 8x20	10	
31	XD0.08.5588G	DADO M8	NUT M8	2	
32	XTE.010.025T	VITE TE 10x25T	SCREW TE 10x25T	1	
33	XRD.006.000	RONDELLA DENTELLATA D.6	TAB WASHER D.6	9	
34	XTE.006.025T	VITE TE M6X25	SCREW TE M6X25	3	
35	XD0.06.5588G	DADO M6	NUT M6	6	

N°	Doc. Number	Titolo	Title	Q.tà	Note
36	XD0.014.5587G	DADO M 14	NUT M 14	4	
37	X40.301.000	LAMIERA DI APPOGGIO SERBATOIO	PLATE TANK	2	
38	XRP.008.000	RONDELLA PIANA D.8	WASHER D.8	12	
39	XTE.008.025T	VITE TE 8X25	SCREW TE M8X25	4	
40	X40.147.000	GUARNIZIONE PER TUNNEL BLITZ 45-50	GASKET FOR TUNNEL 45-50	1	
41	X02.978.000SX	SUPPORTO POMPA TIPO NUOVO	BRACKET	1	
42	XTE.012.040T	VITE TE M12X40 UNI 5739	BOLT TE M12X40	1	
43	X21.005.000	TENDICINGHIA M12 PER POMPA	BELT STRETCHER FOR PUMP	1	
44	XRP.012.000	RONDELLA PIANA D. 12	WASHER D. 12	3	
45	X02.964.000	MOLLA PER POMPA CD 32	CD 32 PUMP SPRING	1	
46	XD0.12.5587	DADO OTTONE M12	M12 BRASS NUT	1	
47	XDA.012.0AG	DADO AUTOBLOCCANTE M12	NUT M12	1	
48	X40.378.000	PIASTRA COPRI RUBINETTI CON INSERTI	PLATE	1	
49	X04.866.150	CARTER ANTERIORE BLITZ 45 1 POMPA	FAN HOUSING 1 PUMP	1	
50	X50.355.000	SUPPORTO ADESIVO PRODOTTO	PRODUCT NOTE SUPPORT	1	
51	XTE.008.016T	VITE TE M8x16	SCREW TE M8x16	2	

N°	Doc. Number	Titolo	Title	Q.tà	Note
53	X04.866.050	CARTER ANTERIORE BLITZ 45 1 POMPA	FAN HOUSING 1 PUMP	1	
54	X40.333.000	COPERCHIO DISINNESTO	FAN CLUTCH LID	1	
55	XD0.06.5589G	DADO M6 BASSO	NUT M6	2	
56	XRD.006.000	RONDELLA DENTELLATA D.6	TAB WASHER D.6	2	
57	XTE.006.016T	VITE TE M6X16	SCREW TE M6X16	2	
58	XRP.006.000	RONDELLA PIANA D. 6	WASHER D.6	2	
59	XDC.06.5721I	DADO DIN 1587 6x1-6-10	NUT DIN 1587 6x1-6-10	2	

N°	Doc. Number	Titolo	Title	Q.tà	Note
60	X04.993.070	CORPO PIEDE D'APPOGGIO	JACK STAND BODY	1	
61	X20.505.000	SPINOTTO PIEDE D' APPOGGIO	PIN JACK STAND	1	
62	X00.100.004	COPIGLIA D.4	SPLIT PIN D.4	1	
63	XCP.006.040I	COPIGLIA D.6 Lg.40	PIN D.6 Lg.40	1	
64	X21.183.000	STRISCIA FERMATAPPI	CAP STOP	2	
65	XD0.06.5588G	DADO M6	NUT M6	1	
66	XTE.006.016T	VITE TE M6X16	SCREW TE M6X16	1	

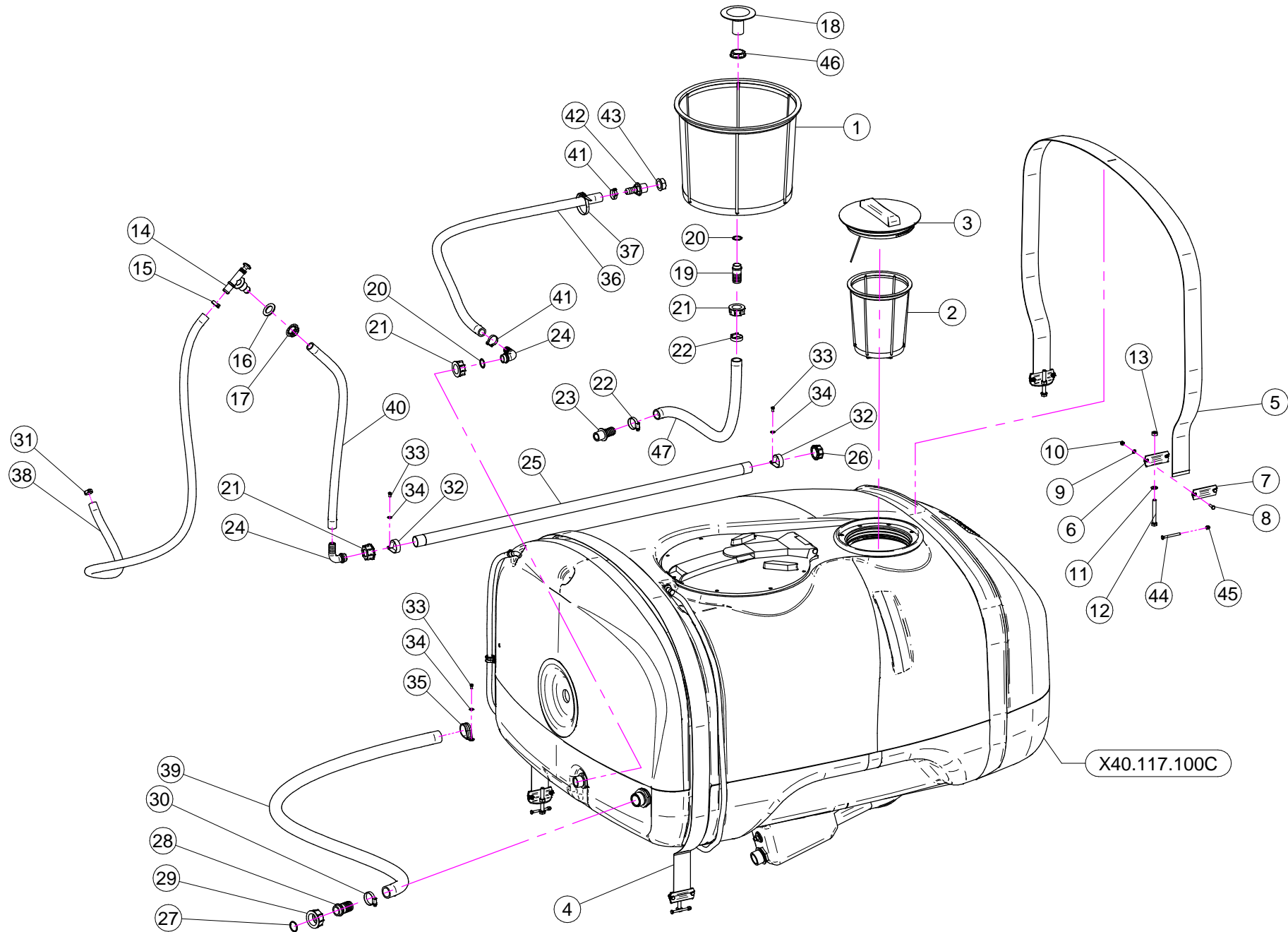

N°	Doc. Number	Titolo	Title	Q.tà	Note
1	X02.404.100	FILTRO A TAZZA 400 x 330	BASKET FILTER 400 x 330	1	
2	X02.298.000	FILTRO A TAZZA D.204	BASKET FILTER D.204	1	
3	X02.476.100	COPERCHIO FILETTATO D.255 CON FILO	THREADED LID D.255 WITH ROPE	1	
4	X02.481.277	FASCIA IN NYLON 60 mm L=2770	NYLON BAND 60 mm L=2770	1	
5	X02.481.253	FASCIA IN NYLON 60 mm L=2530	NYLON BAND 60 mm L=2530	1	
6	X20.512.000	STAFFA ANCORAGGIO FASCE	BRACKET	4	
7	X20.513.000	PIASTRINA SERRAGGIO FASCE	SHAPED PLATE	4	
8	XTE.006.020T	VITE TE M6 x 20	SCREW TE M6 x 20	8	
9	XRP.006.000	RONDELLA PIANA D. 6	WASHER D.6	8	
10	XDA.006.0AG	DADO AUTOBLOCCANTE M6	SELF LOCKING NUT M6	8	
11	XRP.010.000	RONDELLA PIANA D.10	WASHER D.10	4	
12	XTE.010.080T	VITE M10x80	M10x80 BOLT	4	
13	XDOT.10.5587	DADO OTTONE M10	M10 BRASS NUT	4	
14	X02.135.000	VALVOLA A PISTONCINO COMPLETA	COMPLETE PISTON VALVE	1	
15	XFC.023.5.025	FASCETTA COBRA 23,5 - 25	KOBRA CLAMP 23,5 - 25	1	
16	X02.032.000	GUARNIZIONE D.26x40 SP. 2	GASKET D.26x40 SP. 2	1	
17	X00.541.000	GHIERA 3/4"	NUT 3/4"	1	
18	X00.131.000	PRESA ANTIVORTICE 1"	1" VORTIX DAMPER DRIVE	1	
19	X00.055.021	RACCORDO DIRITTO PG D.25	STRAIGHT HOSE R.H D.25	1	
20	XOR.000.132	OR D.23,81 x 2,62	23,81 x 2,62 O-RING GASKET	2	
21	X00.055.24.2	GIRELLO 1" GAS	1" FLY NUT	3	
22	XF0.023.035I	FASCETTA A VITE 23/35 W4 INOX	STAINLESS STEEL CLIP	2	
23	X20.793.000	RACCORDO DIRITTO P.G. D.25 3/4" GAS M.	HOSETAIL R.H. D.25 3/4" GAS M.	1	
24	X00.055.038	RACCORDO CURVO A P.G. D.19	CURVED UNION WITH R.H. D.19	2	

N°	Doc. Number	Titolo	Title	Q.tà	Note
25	X40.035.001	TUBO FORATO 1" L=1200	PERFORATED HOSE 1" L=1200	1	
26	XTF.001.000	TAPPO 1"	PACKING	1	
27	XOR.003.112	OR D.28,24x2,62	O-RING D.28,24x2,62	1	
28	X00.058.028	RACCORDO DIRITTO PG D. 30	STRAIGHT HOSE R.H D.30	1	
29	X00.058.006	GIRELLO 1" 1/4 GAS	1" 1/4 FLY NUT	1	
30	XF0.025.040I	FASCETTA A VITE 25/40 W4 INOX	STAINLESS STEEL CLIP	1	
31	XFC.022.5.024	FASCETTA COBRA 22,5 - 24	KOBRA CLAMP 22,5 - 24	1	
32	XFN.035.000	FASCETTA IN NYLON PER TUBI D. 30	STICKER	2	
33	XTE.005.010I	VITE TE M5 x 10	SCREW TE M5 X 10	3	
34	XRP.005.015I	RONDELLA PIANA D. 5x15	WASHER D. 5x15	3	
35	XFG.040.000	FASCETTA GOMMATA PER TUBI D.30	STICKER	1	
36	X02.212.130	TUBO D. 19x28 L= 130	HOSE D. 19x28 L= 130	1	
37	X02.355.000	FASCETTA D'ASSEMBLAGGIO 292 mm	NYLON ASSEMBLY CLAMP	3	
38	X02.372.125	TUBO SPIRALATO D. 19 L= 1250	HOSE D. 19 L= 1250	1	
39	X02.238.120	TUBO SPIRALATO D. 30 L= 1200	HOSE D. 30 L= 1200	1	
40	X02.212.075	TUBO D. 19x26 L= 750	HOSE D. 19x26 L= 750	1	
41	XFC.027.5.029	FASCETTA COBRA 27,08 - W8	KOBRA CLAMP 27,08 - W8	2	
42	X00.418.000	RACCORDO DIRITTO P.G. 19 3/4" GAS	STRAIGHT UNION R.H.19 3/4 GAS	1	
43	X02.182.100	TAPPO 3/4" FEMMINA CON FORO D. 8	FEMALE 3/4" CAP	1	
44	XTE.006.060I	VITE TE M6x60 INOX	INOX M6x60 TE SCREW	4	
45	XDC.06.5721I	DADO DIN 1587 6x1-6-10	NUT DIN 1587 6x1-6-10	4	
46	X00.542.000	GHIERA 1"	NUT 1"	1	
47	X20.809.120	TUBO D.25 CON RAMINO L=1200	HOSE D.25 L=1200	1	

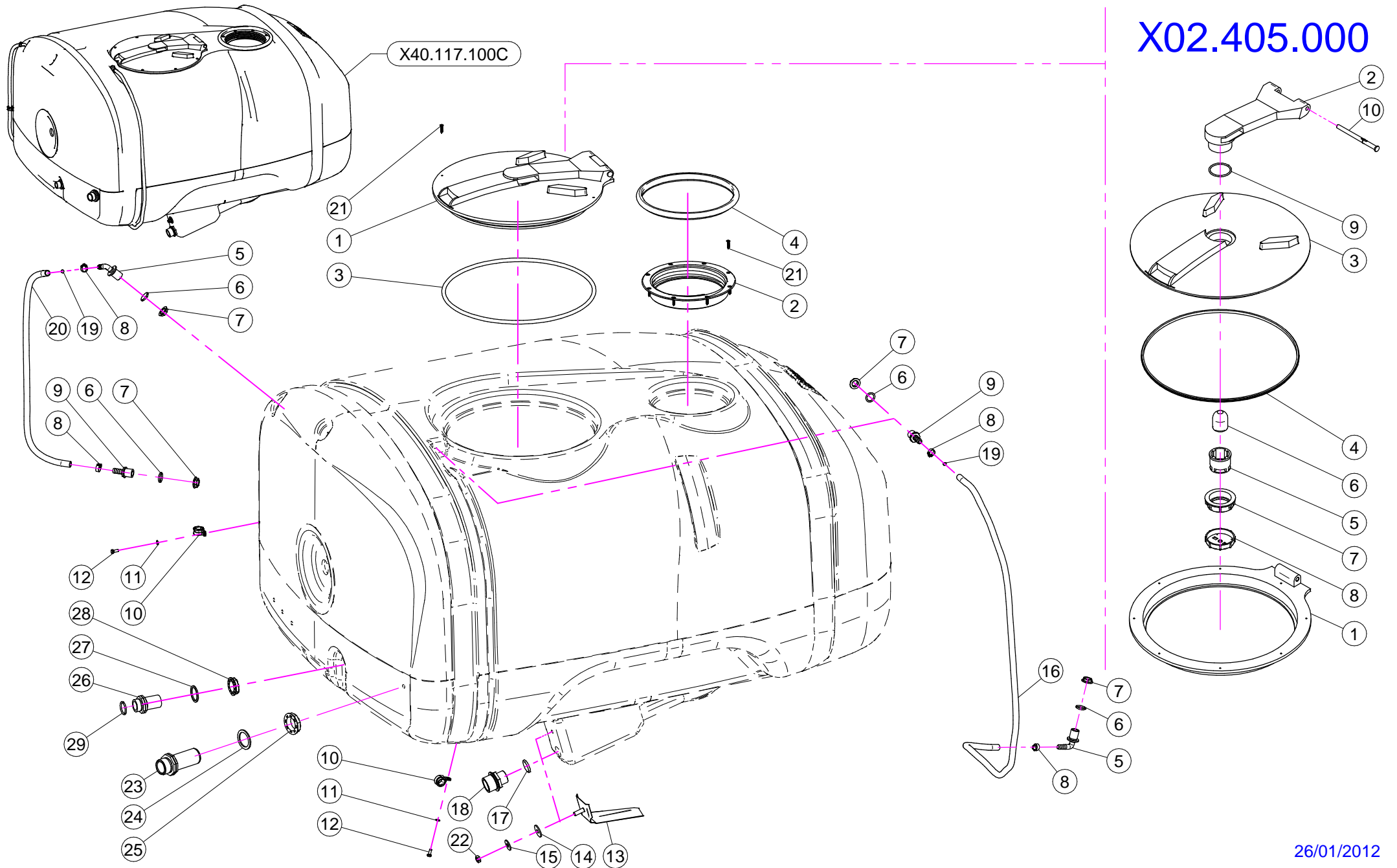

N°	Doc. Number	Titolo	Title	Q.tà	Note
1	X02.405.000	COPERCHIO RIBALTABILE	HINGED TANK LID	1	
2	X02.477.000	ANELLO FILETTATO D.255	THREADED RING D.255	1	
3	X02.405.000.L	GUARNIZIONE	GASKET	1	
4	X02.477.000.A	GUARNIZIONE PER ANELLO FILETTATO D.255	THREADED RING GASKET D.255	1	
5	X02.457.000	PORTAGOMMA D.13 A 90° M. 1/2"	HOSETAIL D.13 90° M. 1/2"	2	
6	XOR.004.081	OR D.20,22 x 3,53	20,22 x 3,53 O-RING GASKET	4	
7	X02.458.000	GHIERA 1/2"	LOCK RING 1/2"	4	
8	XFC.016,5.018	FASCETTA COBRA 16,5 - 18	KOBRA CLAMP 16,5 - 18	4	
9	X02.482.000	RACCORDO DRITTO P.G.D.13 M. 1/2"	HOSETAIL MALE THREADED 1/2"	2	
10	XFG.018.000	FASCETTA GOMMATA PER TUBI D.18	STICKER	2	
11	XRP.006.000	RONDELLA PIANA D. 6	WASHER D.6	2	
12	XTE.006.016T	VITE TE M6X16	SCREW TE M6X16	2	
13	X20.498.002	ANTIVORTICE IN ACCIAIO INOX	STAINLESS STEEL ANTI-VORTEX	1	
14	X20.436.000	GUARNIZIONE SPECIALE PER ANTIVORTICE	SPECIAL GARNISHING FOR ANTIWHIRL	1	
15	XRP.010.030	RONDELLA PIANA D.10 x 30 mm	WASHER D.10 x 30 mm	1	
16	X02.378.160	TUBETTO VITREO D.12X16 L=1600	HOSE VITREO D.12X16 L=1600	1	
17	XOR.000.507	OR D.27 x 5	27 x 5 O-RING GASKET	1	
18	X00.045.012	RIDUZIONE 1" 1/4 M - 1" M	1" 1/4 M - 1" M REDUCER NIPPLE	1	
19	X02.478.000	SFERA ROSSA D.8,5 PER LIVELLO	RED FLOATING BALL D.8,5	2	
20	X02.378.085	TUBETTO VITREO D 12X16 L= 850	HOSE VITREO D 12X16 L= 850	1	
21	XTAS.04,2.025I	VITE AUTOFILETTANTE 4,2 x 25	SELFTHREADED SCREW 4,2 x 25	16	
22	XDOT.10.5587	DADO OTTONE M10	M10 BRASS NUT	1	
23	X00.345.000	NIPPLO 1" 1/4 + 1" 1/4 GAS	NIPPLE 1" 1/4 + 1" 1/4 GAS	1	
24	X02.033.000	GUARNIZIONE	GASKET	1	
25	X00.543.000	GHIERA 1" 1/4 GAS	NUT 1" 1/4 GAS	1	
26	X00.055.134.L	NIPPLO 1" / 1" GAS FILETTO LUNGO TAGLIATO	CUTTED LONG NIPPLE 1" / 1" GAS	1	
27	X02.066.000	GUARNIZIONE D.33 x 45	GASKET D.33 x 45	1	
28	X00.542.000	GHIERA 1"	NUT 1"	1	
29	XOR.004.118	OR D.29,75 x 3,53	29,75 x 3,53 O-RING GASKET	1	

X02.405.000

N°	Doc. Number	Titolo	Title	Q.tà	Note
1	X02.405.000.B	ANELLO BASE	BASE RING	1	
2	X02.405.001	BRACCIO	ARM	1	
3	X02.405.000.A	DISCO DI CHIUSURA	GRIPPING PLATE	1	
4	X02.405.002	GUARNIZIONE SAGOMATA	SHAPED GASKET	1	
5	X20.787.000.G	CORPO VALVOLA DI SFIATO	BREATHER VALVE	1	
6	X20.787.000.F	SFERA GALLEGGIANTE	FLOATING BALL	1	
7	X20.787.000.H	GHIERA	RING NUT	1	
8	X20.787.000.I	TAPPO PER VALVOLA DI SFIATO	CAP FOR BREATHER VALVE	1	
9	XOR.000.512	OR D.51 x 3,5	51 x 3,5 O-RING GASKET	1	
10	X20.787.000.D	PERNO	PIN	1	

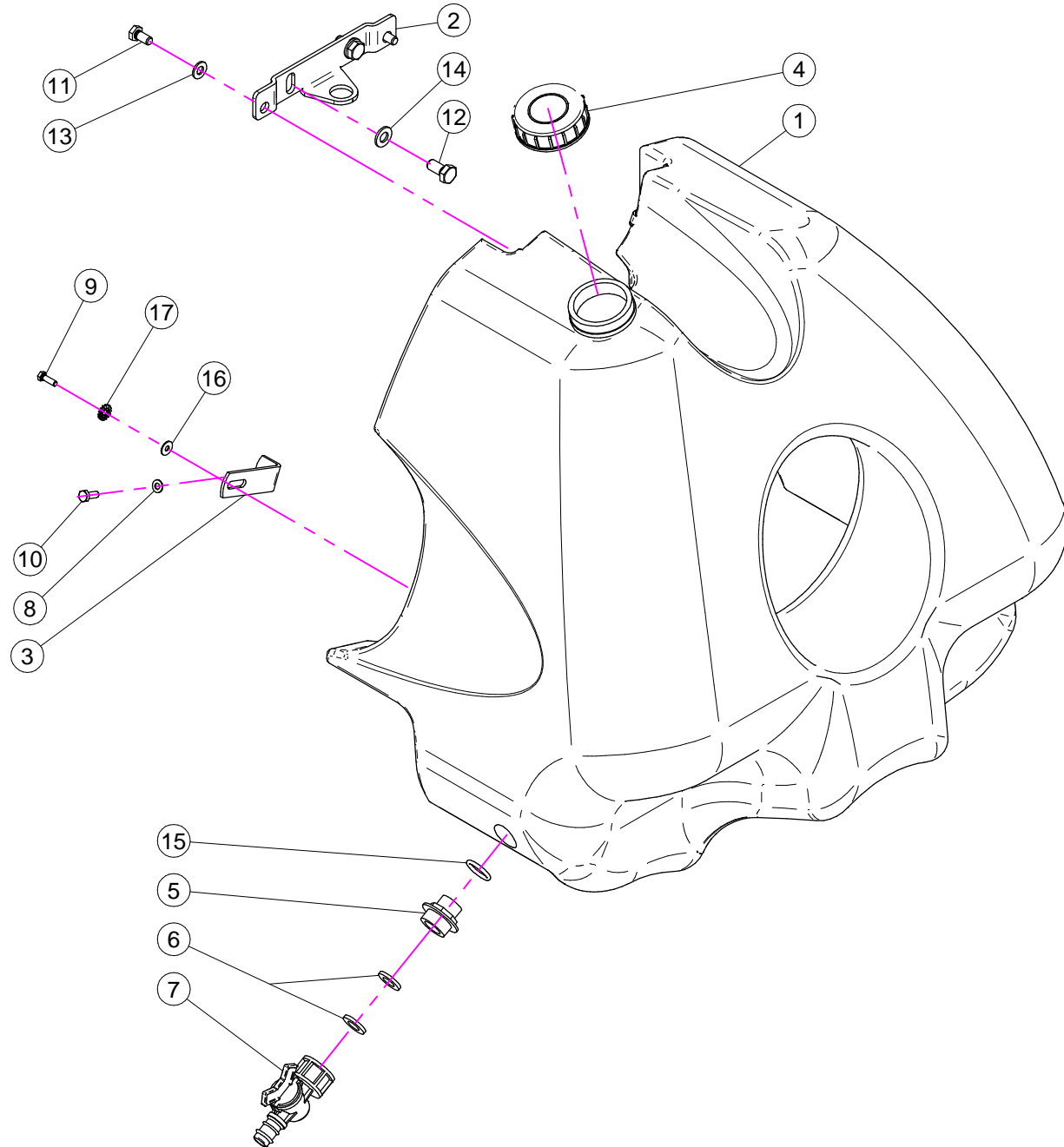
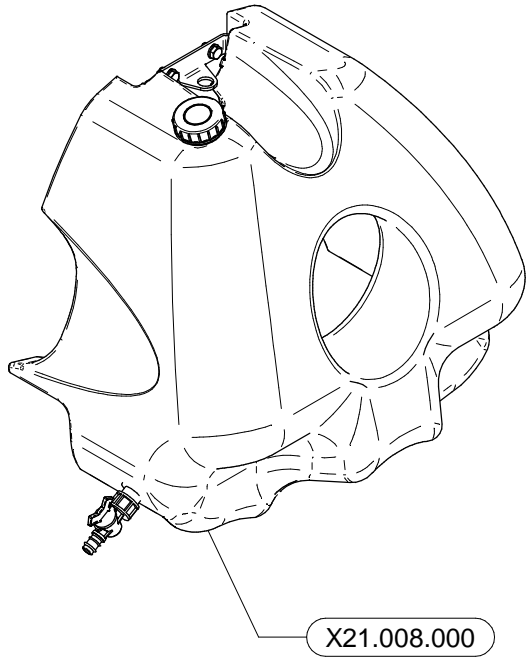

N°	Doc. Number	Titolo	Title	Q.tà	Note
1	X40.322.000	SERBATOIO LAVAMANI 30 Lt.	HAND-WASHING TANK 30 Lt.	1	
2	X40.323.000	STAFFA FISSAGGIO SERBATOIO LAVAMANI	FIXING BRACKET	1	
3	X40.324.000	PIASTRA PER SERBATOIO LAVAMANI SERIE 45	BRACKET FOR HAND-WASHING TANK 45 SERIES	2	
4	X02.460.000	COPERCHIO FILETTATO FEMMINA	FEMALE THREADED TANK LID	1	
5	X00.055.044	NIPPLO 1/2" GAS 3/4" GAS	NIPPLE 1/2" - 3/4" GAS	1	
6	X02.030.010	GUARNIZIONE TAPPO DISTRIBUTORE	GASKET	2	
7	X02.497.000	RUBINETTO FEMMINA 3/4"	3/4" FEMALE VALVE	1	
8	XRP.006.000	RONDELLA PIANA D. 6	WASHER D.6	2	
9	XTE.005.016I	VITE TE M5X16	SCREW TE M5X16	2	
10	XTE.006.016T	VITE TE M6X16	SCREW TE M6X16	2	
11	XTE.008.016T	VITE TE M8x16	SCREW TE M8x16	2	
12	XTE.010.020T	VITE TE M10 x 20	SCREW TE M10 x 20	2	
13	XRP.008.000	RONDELLA PIANA D.8	WASHER D.8	2	
14	XRP.010.000	RONDELLA PIANA D.10	WASHER D.10	2	
15	XOR.004.081	OR D.20,22 x 3,53	20,22 x 3,53 O-RING GASKET	1	
16	XRP.005.015I	RONDELLA PIANA D. 5x15	WASHER D. 5x15	2	
17	XRD.006.000	RONDELLA DENTELLATA D.6	TAB WASHER D.6	2	

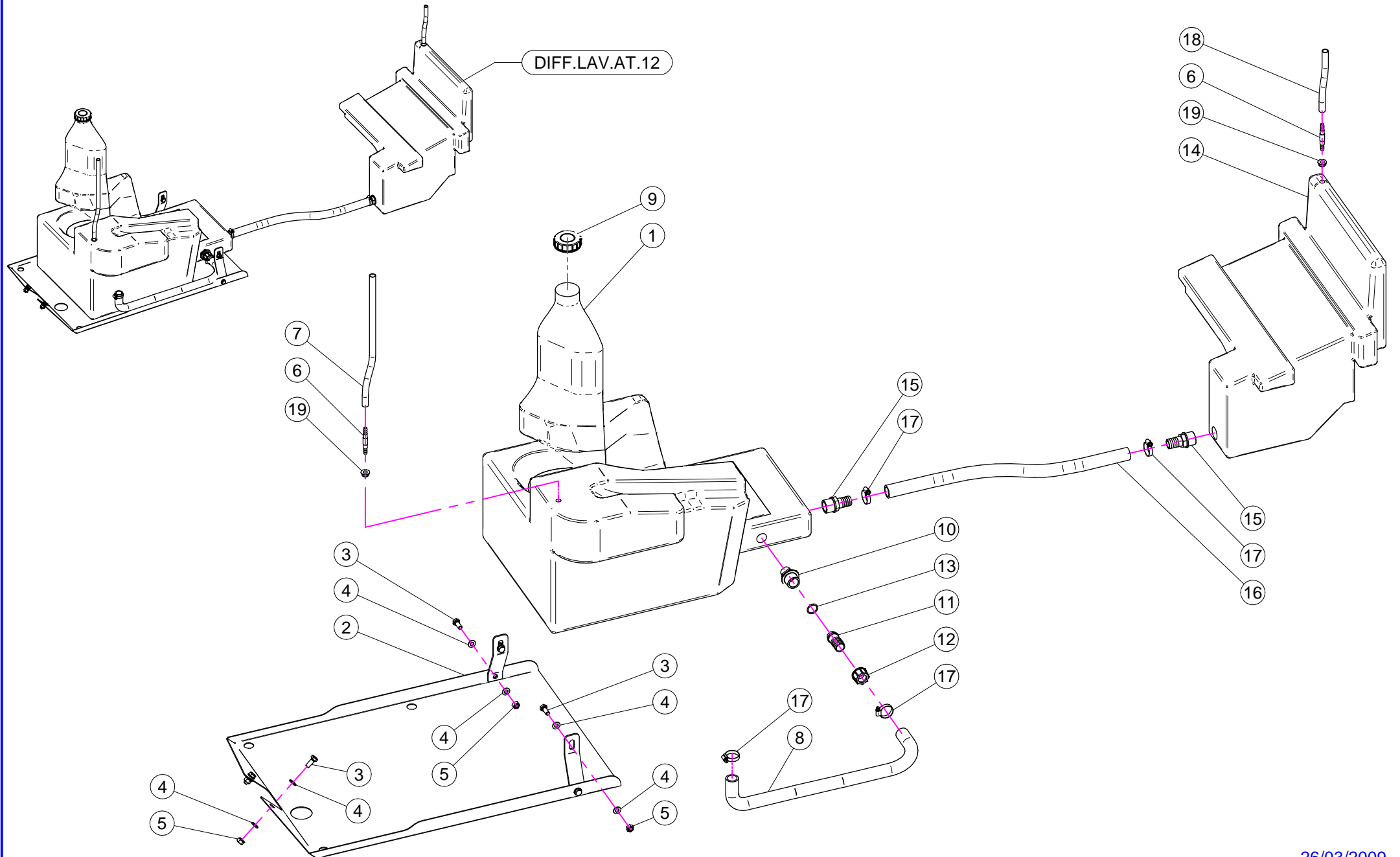

N°	Doc. Number	Titolo	Title	Q.tà	Note
1	X40.299.000	SERBATOIO LAVAIMPIANTI LT. 60	RESERVOIR TANK LT. 60	1	
2	X40.306.000	PROTEZIONE LAVAIMPIANTI	RESERVOIR KIT PROTECTION	1	
3	XTE.010.025T	VITE TE 10x25T	SCREW TE 10x25T	6	
4	XRP.010.000	RONDELLA PIANA D.10	WASHER D.10	12	
5	XD0.10.5587G	DADO M10	NUT M10	6	
6	X20.934.000	PORTAGOMMA D.8	STRAIGHT HOSE D.8	2	
7	X02.213.060	TUBETTO DI SFIATO D.10 L=600	BREATHER PIPE D.10 L=600	1	
8	X02.219.090	TUBO D.25 L= 900	PIPE D. 25 L=900	1	
9	X02.460.000	COPERCHIO FILETTATO FEMMINA	FEMALE THREADED TANK LID	1	
10	X02.293.000	RIDUZIONE 1" M - 3/4" M	1" M - 3/4" M REDUCER NIPPLE	1	
11	X00.055.021	RACCORDO DIRITTO PG D.25	STRAIGHT HOSE R.H D.25	1	
12	X00.055.24.2	GIRELLO 1" GAS	1" FLY NUT	1	
13	XOR.000.132	OR D.23,81 x 2,62	23,81 x 2,62 O-RING GASKET	1	
14	X40.298.000	SERBATOIO LAVAIMPIANTI LT. 25	RESERVOIR TANK LT. 25	1	
15	X02.403.000	RACCORDO DIRITTO PG D.25 - 1"	STRAIGHT HOSE R. H D.25 - 1"	2	
16	X02.219.100	TUBO D.25 L=1000	PIPE D.25 L=1000	1	
17	XF0.023.035I	FASCETTA A VITE 23/35 W4 INOX	STAINLESS STEEL CLIP	4	
18	X02.213.020	TUBETTO DI SFIATO D.10 L=200	BREATHER PIPE D.10 L=200	1	
19	X20.933.000	GUARNIZIONE SFIATO SERBATOIO	TANK BREATHER GASKET	2	

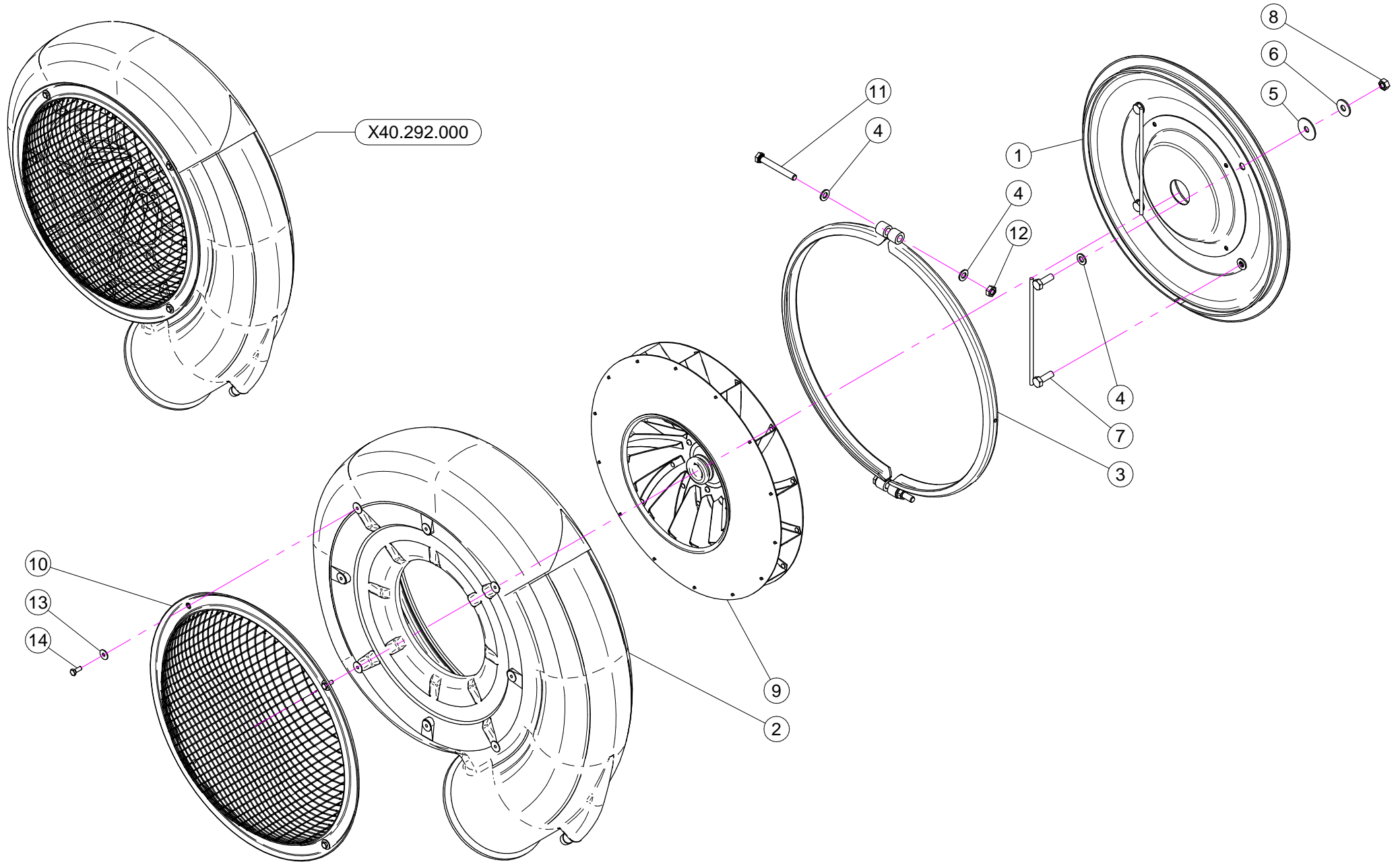

N°	Doc. Number	Titolo	Title	Q.tà	Note
1	X40.268.000	COPERCHIO VENTOLA 45	FAN 45 COVER	1	
2	X04.854.000	CARTER VENTOLA P/T45N	FAN CASING P/T45N	1	
3	X04.874.000.Z	COLLARE D.485 ZINCATO	D.485 CLAMP	1	
4	XRP.010.000	RONDELLA PIANA D.10	WASHER D.10	8	
5	XRP.010.040	RONDELLA PIANA D.10 X 40	WASHER D.10 X 40	4	
6	XRP.010.030	RONDELLA PIANA D.10 x 30 mm	WASHER D.10 x 30 mm	4	
7	X20.088.000	CAVALLOTTO POSTERIORE CARTER VENTOLA	BACK COVER BRACKET	2	
8	XD0.10.5587G	DADO M10	NUT M10	4	
9	X04.720.000	VENTOLA D.450 X P/T/LP/TP45	FAN 450	1	
10	X05.654.200	RETE PROTEZIONE VENTILATORE	FAN NET PROTECTION	1	
11	XTE.010.080T	VITE M10x80	M10x80 BOLT	2	
12	XDOT.10.5587	DADO OTTONE M10	M10 BRASS NUT	2	
13	XRP.006.018	RONDELLA PIANA D. 6x18	WASHER D.6x18	4	
14	XTE.006.016T	VITE TE M6X16	SCREW TE M6X16	4	

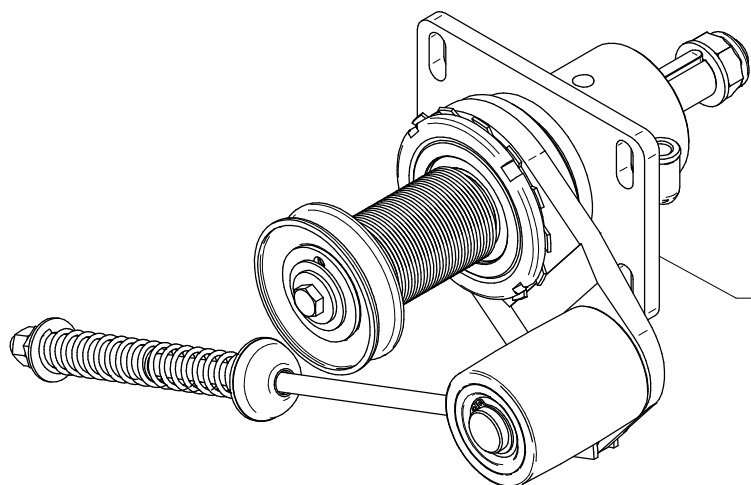

X40.286.000 Sez. 04 Plus 45 - P 45

X40.287.000 Sez. 04 Blitz 45 - Gp 45

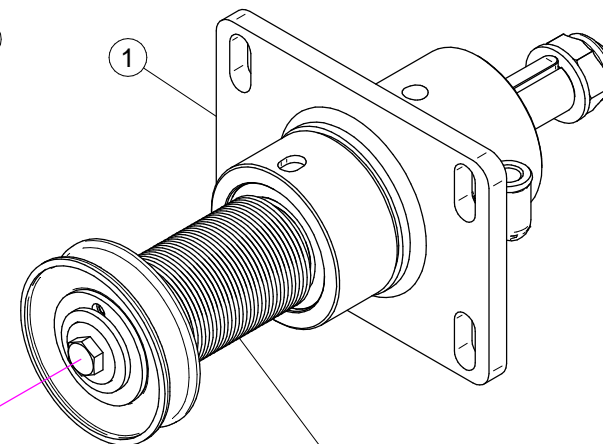

X40.284.000 Sez. 04A

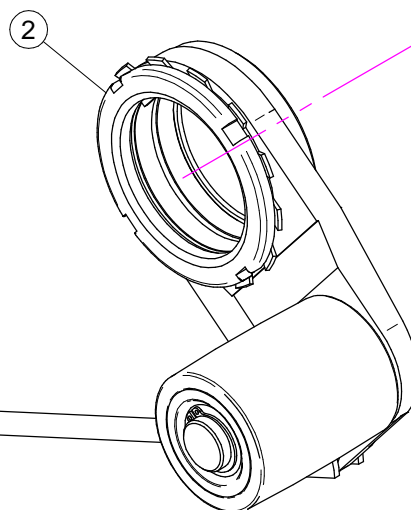

X04.850.002 Sez. 04B Plus 45 - P 45

X04.850.000 Sez. 04B Blitz 45 - Gp 45 -Maxi 600

X40.286.000

N°	Doc. Number	Titolo	Title	Q.tà	Note
1	X40.284.000	SUPPORTO OLIO 45 - PUL. D.54 SENZA DISINNESTO	FAN SUPPORT - PUL D.54 NO DISENGAGEMENT	1	
2	X04.850.002	TENDICINGHIA AUTOMATICO COMPLETO	AUTOMATIC BELT STRETCHER	1	

X40.287.000

N°	Doc. Number	Titolo	Title	Q.tà	Note
1	X40.284.000	SUPPORTO OLIO 45 - PUL. D.54 SENZA DISINNESTO	FAN SUPPORT - PUL D.54 NO DISENGAGEMENT	1	
2	X04.850.000	TENDICINGHIA AUTOMATICO COMPLETO	AUTOMATIC BELT STRETCHER	1	

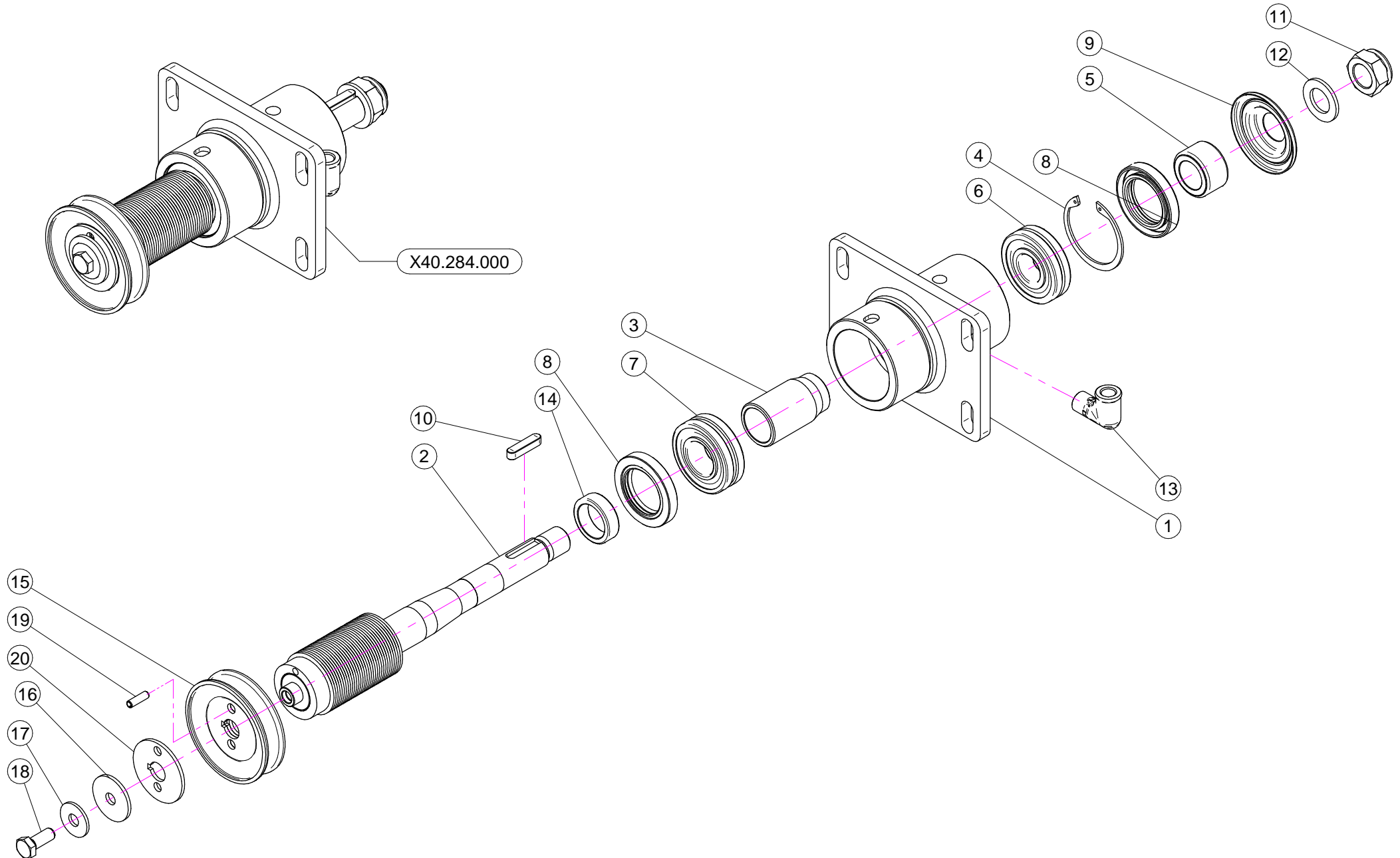

N°	Doc. Number	Titolo	Title	Q.tà	Note
1	X40.260.000	SUPPORTO VENTILATORE NUDO	FAN SUPPORT	1	
2	X40.271.054	ALBERO CON PULEGGIA D. 54 J32	SHAFT WITH PULLEY D.54 J32	1	
3	X40.262.000	DISTANZIALE SUPPORTO VENTILATORE	SPACER FAN SUPPORT	1	
4	XI0.062.000	ANELLO ELASTICO INTERNO D. 62	INTERNAL D. 62 CIRCLIP	1	
5	X40.263.000	DISTANZIALE TENUTA LATO VENTOLA	SIDE FAN SEAL SPACER	1	
6	XK0.021.305	CUSCINETTO A RULLI OBLIQUI 21.305	BEARING TO OBLIQUE SEAMS 21.305	1	
7	XK0.022.206	CUSCINETTO A RULLI OBLIQUI 22.206	BEARING TO OBLIQUE SEAMS 22.206	1	
8	XBASL.40.62.10	ANELLO DI TENUTA IN VITON 40.62.10	VITON LIP SEALS IEL 40.62.10	2	
9	X40.267.000	COPERCHIETTO LATO VENTOLA	SIDE FAN COVER	1	
10	XL.08.07.35	LINGUETTA 8x7x35	8x7x35 TANG	1	
11	XDA.022.0BF	DADO ESAGONALE M22 AUTOBLOCCANTE	SELF-LOCKING NUT M22 x 1,5	1	
12	XRP.022.000	RONDELLA PIANA D.22	WASHER D.22	1	
13	X20.789.000	GOMITO 90° TUBO DI CARICO OLIO	MALE/FEMALE 90° ELBOW	1	
14	X40.264.000	DISTANZIALE PER TENUTA LATO PULEGGIA	SPACER	1	
15	X02.723.003	PULEGGIA COMANDO POMPA D.78 X 1 3V	PULLEY FOR PUMP D.78 X 1 3V	1	
16	XRP.010.040	RONDELLA PIANA D.10 X 40	WASHER D.10 X 40	1	
17	XRP.010.030	RONDELLA PIANA D.10 x 30 mm	WASHER D.10 x 30 mm	1	
18	XTE.010.025FT	VITE TE M10x25	BOLT TE M10x25	1	
19	XSE.006.020	SPINA ELASTICA D.6x20	SPRING PIN D.6x20	1	
20	X02.723.001	RONDELLA SPECIALE mm3	SPECIAL WASHER mm3	1	

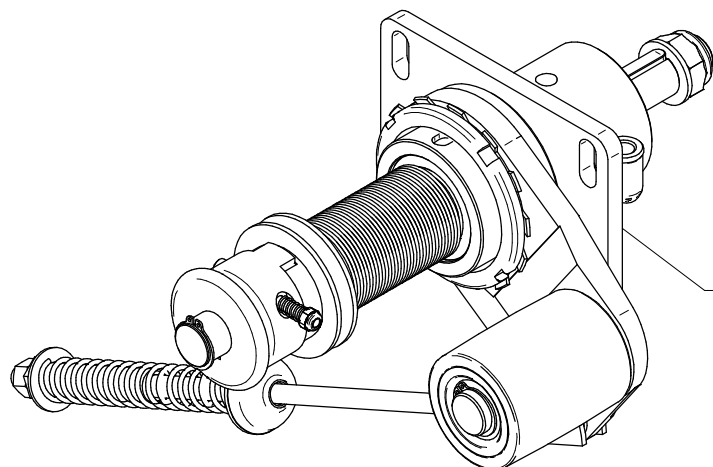

X40.276.000 Sez. 04 Plus 45 - P 45

X40.277.000 Sez. 04 Blitz 45 - Gp 45

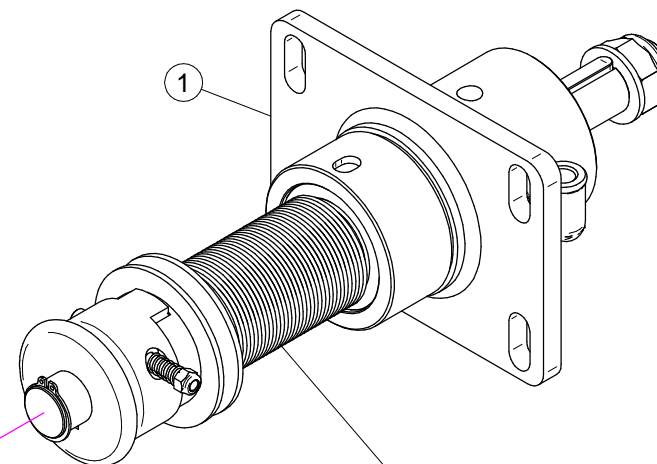

X40.274.000 Sez. 04A

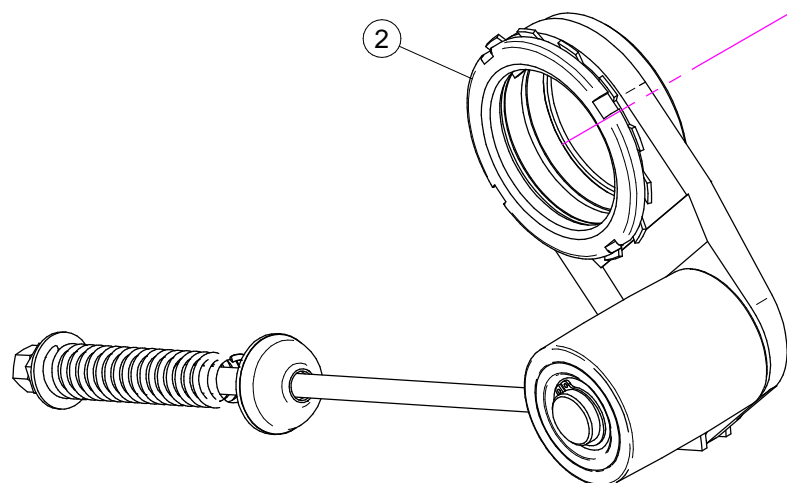

X04.850.002 Sez. 04B Plus 45 - P 45

X04.850.000 Sez. 04B Blitz 45 - Gp 45 - Maxi 600

X40.276.000

N°	Doc. Number	Titolo	Title	Q.tà	Note
1	X40.274.000	SUPPORTO OLIO 45 - PUL. D.54 DISINNESTO	FAN SUPPORT - PUL D.54 DISENGANGEMENT	1	
2	X04.850.002	TENDICINGHIA AUTOMATICO COMPLETO	AUTOMATIC BELT STRETCHER	1	

X40.277.000

N°	Doc. Number	Titolo	Title	Q.tà	Note
1	X40.274.000	SUPPORTO OLIO 45 - PUL. D.54 DISINNESTO	FAN SUPPORT - PUL D.54 DISENGANGEMENT	1	
2	X04.850.000	TENDICINGHIA AUTOMATICO COMPLETO	AUTOMATIC BELT STRETCHER	1	

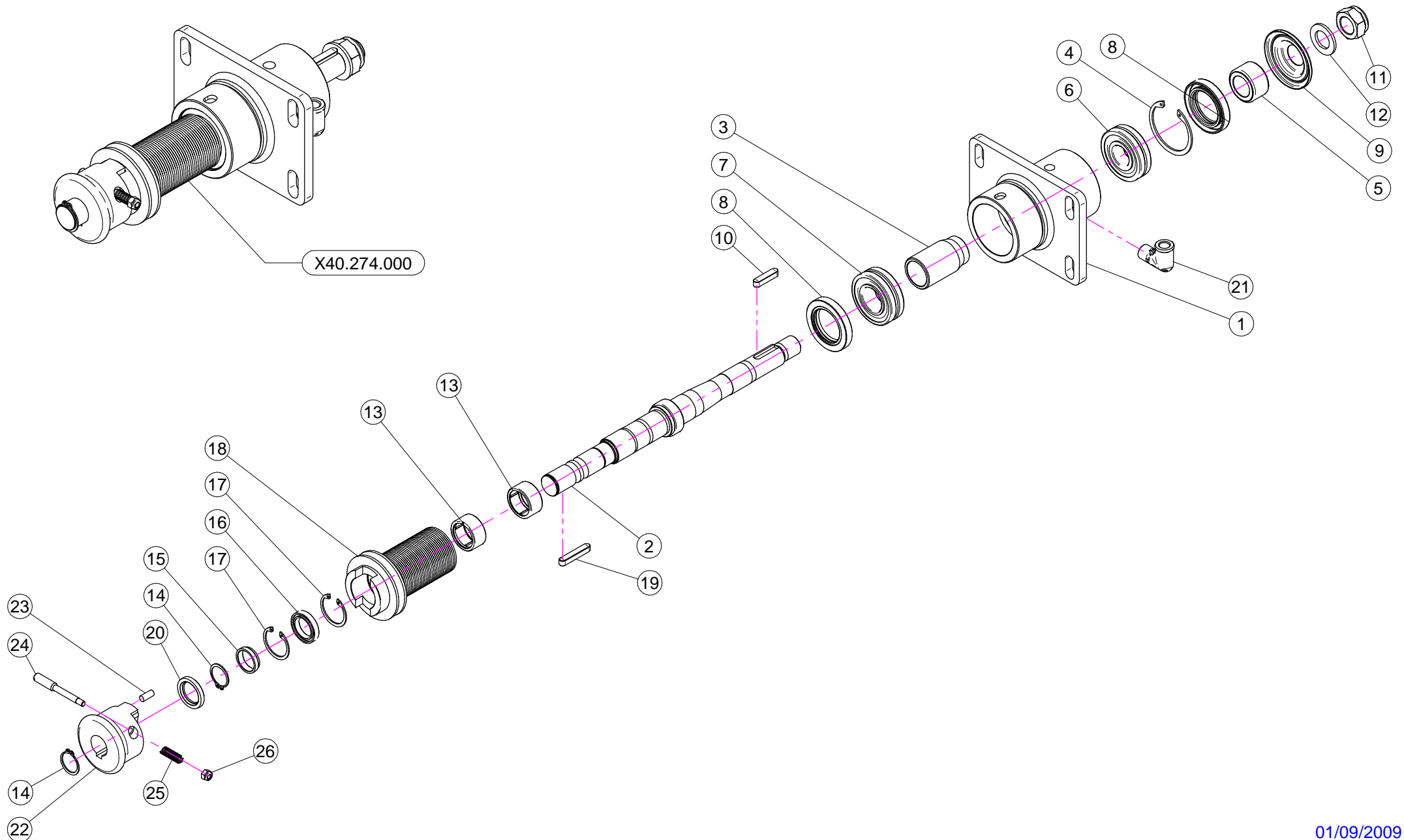

N°	Doc. Number	Titolo	Title	Q.tà	Note
1	X40.260.000	SUPPORTO VENTILATORE NUDO	FAN SUPPORT	1	
2	X40.261.000	ALBERO VENTILATORE PER DISINNESTO	FAN RELEASE SHAFT	1	
3	X40.262.000	DISTANZIALE SUPPORTO VENTILATORE	SPACER FAN SUPPORT	1	
4	XI0.062.000	ANELLO ELASTICO INTERNO D. 62	INTERNAL D. 62 CIRCLIP	1	
5	X40.263.000	DISTANZIALE TENUTA LATO VENTOLA	SIDE FAN SEAL SPACER	1	
6	XK0.021.305	CUSCINETTO A RULLI OBLIQUI 21.305	BEARING TO OBLIQUE SEAMS 21.305	1	
7	XK0.022.206	CUSCINETTO A RULLI OBLIQUI 22.206	BEARING TO OBLIQUE SEAMS 22.206	1	
8	XBASL.40.62.10	ANELLO DI TENUTA IN VITON 40.62.10	VITON LIP SEALS IEL 40.62.10	2	
9	X40.267.000	COPERCHIETTO LATO VENTOLA	SIDE FAN COVER	1	
10	XL.08.07.35	LINGUETTA 8x7x35	8x7x35 TANG	1	
11	XDA.022.0BF	DADO ESAGONALE M22 AUTOBLOCCANTE	SELF-LOCKING NUT M22 x 1,5	1	
12	XRP.022.000	RONDELLA PIANA D.22	WASHER D.22	1	
13	XK0.HK3.020	CUSCINETTO A RULLINI SENZA GABBIA	NEEDLE BEARING WITHOUT CAGE	2	
14	XE0.025.000	ANELLO ELASTICO ESTERNO D. 25	EXTERNAL D. 25 CIRCLIP	2	
15	X04.706.000	DISTANZIALE LATO DISINNESTO	SIDE DISENGAGEMENT SPACER	1	
16	XK0.061.805.EE	CUSCINETTO RADIALE A SFERE 61.805.EE	ROLLING BEARING 61.805.EE	1	
17	XI0.037.000	ANELLO ELASTICO INTERNO D. 37 TIPO ANDERTON	INTERNAL D. 37 ANDERTON TYPE CIRCLIP	2	
18	X04.702.000	PULEGGIA D. 54 J32 PER DISINNESTO	PULEY D. 54 J32 FOR DISENGAGEMENT	1	
19	XL.08.07.45	LINGUETTA 8x7x45	8x7x45 TANG	1	
20	XBA.25.37.05	ANELLO DI TENUTA 25x37x5	25x37x5 SEALING RING	1	
21	X20.789.000	GOMITO 90° TUBO DI CARICO OLIO	MALE/FEMALE 90° ELBOW	1	
22	X04.704.000	DISINNESTO PER 45 NUDO	NUDE FOR 45 DISENGAGEMENT	1	
23	X04.881.016	AMMORTIZZATORE CILINDRICO DISINNESTO	VULCOLAN RELEASE SHOCK	4	
24	X04.705.000	PULSANTE PER DISINNESTO	PUSH FOR DISENGAGEMENT	1	
25	X02.502.001	MOLLA A COMPRESSIONE	SPRING	1	
26	XDA.006.0AG	DADO AUTOBLOCCANTE M6	SELF LOCKING NUT M6	1	

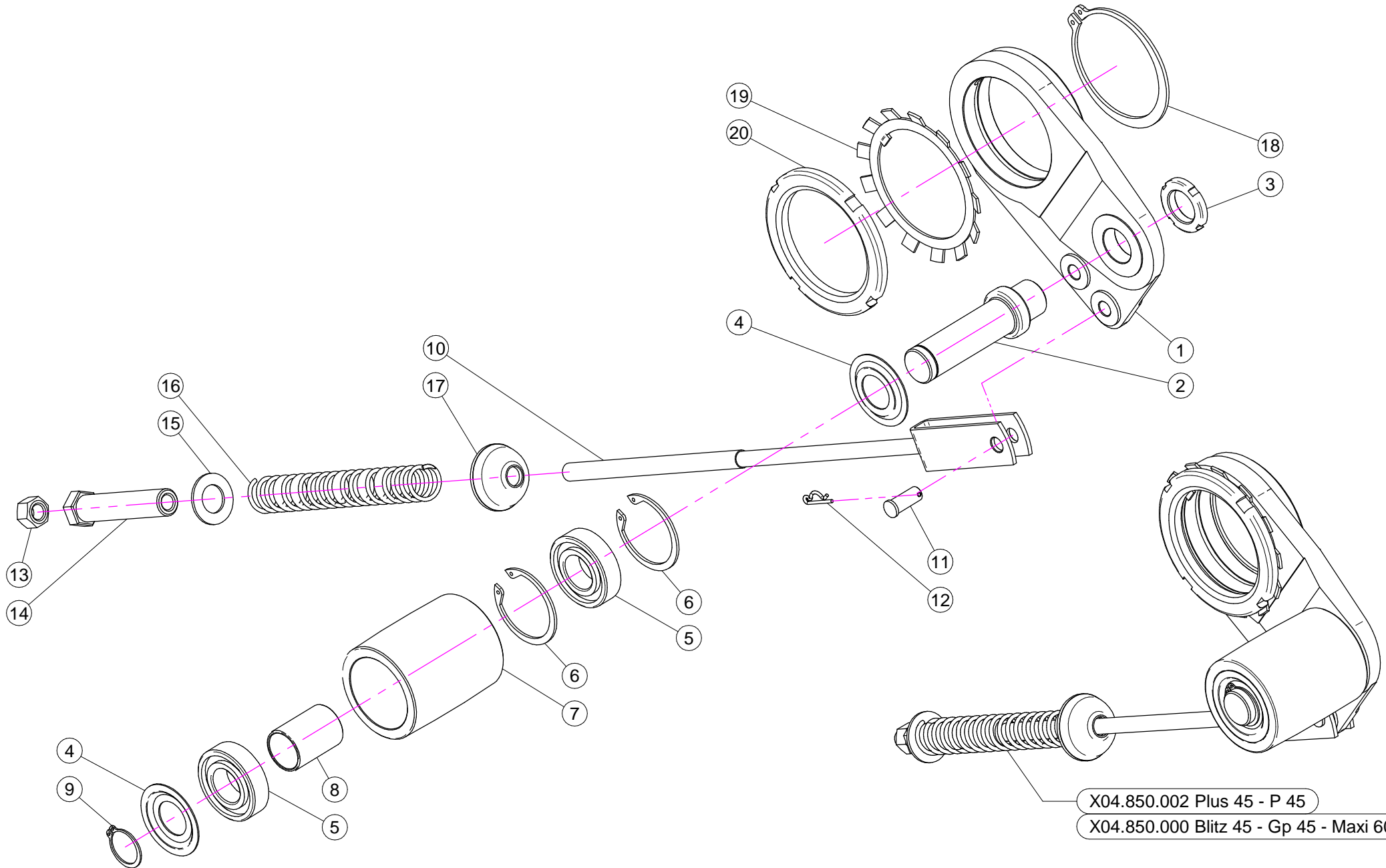

X04.850.002 Plus 45 - P 45
X04.850.000 Blitz 45 - Gp 45 - Maxi 600

X04.850.002 PLUS 45 - P 45

N°	Doc. Number	Titolo	Title	Q.tà	Note
1	X04.095.000	SUPPORTO PER TENDICINGHIA AUTOMATICO	BELT STRETCHER HOUSING	1	
2	X04.835.000	PERNO PER TENDICINGHIA AUTOMATICO	BELT STRETCHER PIN	1	
3	XKM.005.000	GHIERA KM5	NUT KM5	1	
4	X04.585.000	COPERCHIO PARAPOLVERE TENDICINGHIA	ANTI - DUST COVER	2	
5	XK6.205.2RS	CUSCINETTO 6205-2RS	ROLLER BEARING 6205-2RS	2	
6	XI0.052.000	ANELLO ELASTICO INTERNO D. 52	INTERNAL D. 52 CIRCLIP	2	
7	X04.083.000	RULLO TENDICINGHIA AUTOMATICO	ROLLER FOR BELT STRETCHER	1	
8	X04.084.000	DISTANZIALE PER TENDICINGHIA AUTOMATICO	SPACER FOR BELT STRETCHER	1	
9	XE0.025.000	ANELLO ELASTICO ESTERNO D. 25	EXTERNAL D. 25 CIRCLIP	1	
10	X05.653.000	FORCELLA TENSIONE TENDICINGHIA	BELT TRETCHER FORK	1	*
11	X04.593.000	PERNO FORCELLA TENDICINGHIA	PIN	1	
12	X00.100.002	COPIGLIA	CLIP	1	
13	XD0.12.5587G	DADO M12 PG UNI 5587	M12 NUT	1	
14	X04.583.000	VITE SPECIALE MOLLA TENDICINGHIA	SPECIAL SCREW	1	
15	XRP.019.000	RONDELLA PIANA D.19 6592	WASHER D.19	1	
16	X04.093.100	MOLLA TENDICINGHIA AUTOMATICO	SPRING	1	
17	X20.260.000	RONDELLA BOMBATA D.12 PER TENDICINGHIA	SPECIAL WASHER D.12	1	
18	XE0.080.000	ANELLO ELASTICO ESTERNO D.80	EXTERNAL D 80 CIRCLIP	1	
19	XMB.016.000	ROSETTA DI SICUREZZA MB 16	TOOTH LOCK WASHER MB 16	1	
20	X04.099.000	GHIERA DI REGISTRO M 80x2	NUT M 80x2	1	

X04.850.000 BLITZ 45 - GP 45 - MAXI 600

N°	Doc. Number	Titolo	Title	Q.tà	Note
1	X04.095.000	SUPPORTO PER TENDICINGHIA AUTOMATICO	BELT STRETCHER HOUSING	1	
2	X04.835.000	PERNO PER TENDICINGHIA AUTOMATICO	BELT STRETCHER PIN	1	
3	XKM.005.000	GHIERA KM5	NUT KM5	1	
4	X04.585.000	COPERCHIO PARAPOLVERE TENDICINGHIA	ANTI - DUST COVER	2	
5	XK6.205.2RS	CUSCINETTO 6205-2RS	ROLLER BEARING 6205-2RS	2	
6	XI0.052.000	ANELLO ELASTICO INTERNO D. 52	INTERNAL D. 52 CIRCLIP	2	
7	X04.083.000	RULLO TENDICINGHIA AUTOMATICO	ROLLER FOR BELT STRETCHER	1	
8	X04.084.000	DISTANZIALE PER TENDICINGHIA AUTOMATICO	SPACER FOR BELT STRETCHER	1	
9	XE0.025.000	ANELLO ELASTICO ESTERNO D. 25	EXTERNAL D. 25 CIRCLIP	1	
10	X05.653.100	FORCELLA TENSIONE TENDICINGHIA	BELT TRETCHER FORK	1	*
11	X04.593.000	PERNO FORCELLA TENDICINGHIA	PIN	1	
12	X00.100.002	COPIGLIA	CLIP	1	
13	XD0.12.5587G	DADO M12 PG UNI 5587	M12 NUT	1	
14	X04.583.000	VITE SPECIALE MOLLA TENDICINGHIA	SPECIAL SCREW	1	
15	XRP.019.000	RONDELLA PIANA D.19 6592	WASHER D.19	1	
16	X04.093.100	MOLLA TENDICINGHIA AUTOMATICO	SPRING	1	
17	X20.260.000	RONDELLA BOMBATA D.12 PER TENDICINGHIA	SPECIAL WASHER D.12	1	
18	XE0.080.000	ANELLO ELASTICO ESTERNO D.80	EXTERNAL D 80 CIRCLIP	1	
19	XMB.016.000	ROSETTA DI SICUREZZA MB 16	TOOTH LOCK WASHER MB 16	1	
20	X04.099.000	GHIERA DI REGISTRO M 80x2	NUT M 80x2	1	

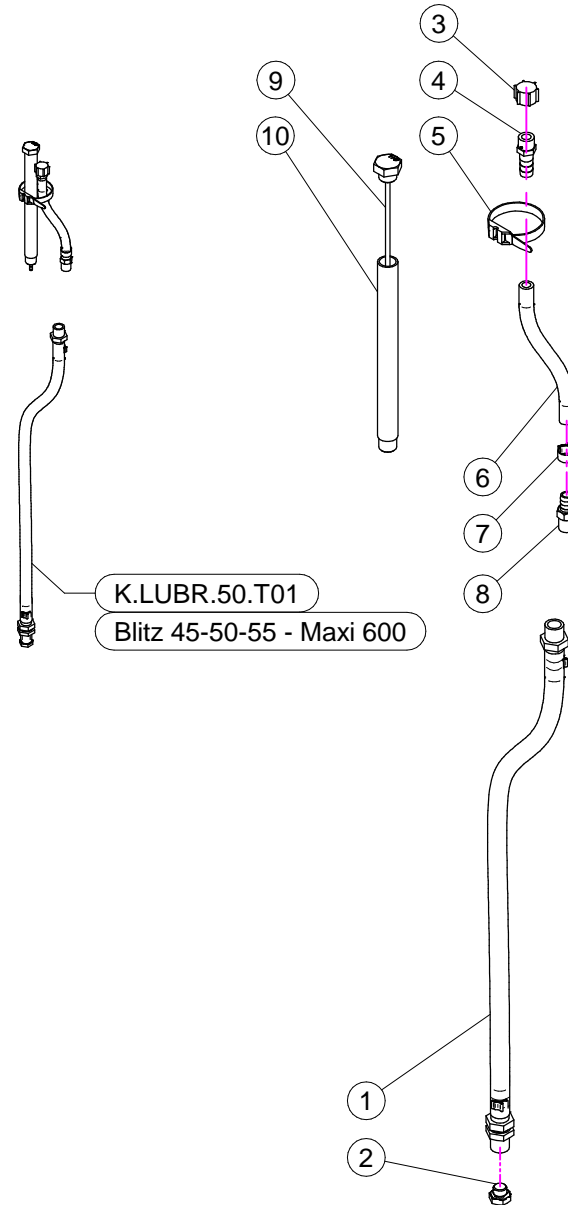
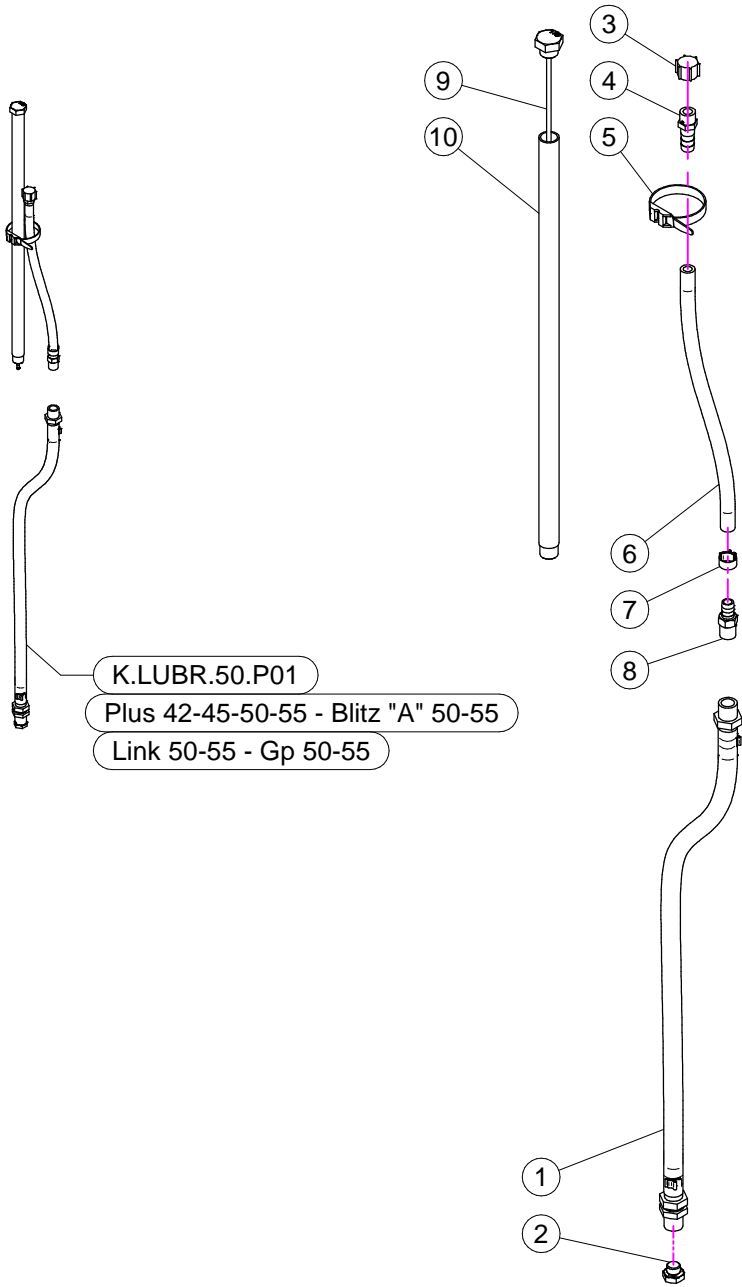

K.LUBR.50.P01 (Plus 42-45-50-55 - Blitz "A" 50-55 - Link 50-55 - Gp 50-55)

N°	Doc. Number	Titolo	Title	Q.tà	Note
1	X20.790.000	TUBO DI SCARICO OLIO 3/8" CIL. - 3/8" CON.	DRAIN PIPE 3/8"	1	
2	X40.266.000	TAPPO SCARICO OLIO M12x1,5	OIL EXHAUSTPLUG	1	
3	X02.013.000	TAPPO CIMA G 1/4" F.	PLUG G 1/4"	1	
4	X00.414.100	PORTAGOMMA D.11 1/4" M. FORATO	STRAIGHT HOSE D.11 1/4" WITH BLEED	1	
5	X02.355.000	FASCETTA D'ASSEMBLAGGIO 235 mm	NYLON ASSEMBLY CLAMP	1	
6	X02.217.025	TUBO D. 8x13 L= 250	HOSE D. 8x13 L= 250	1	
7	XFC.014,5.016	FASCETTA COBRA SLO30716	KOBRA CLAMP	1	
8	X20.792.000	PORTAGOMMA D.11 G 1/4" M. PER SFIATO	STRAIGHT HOSE D.11 G 1/4" FOR BREATHER	1	
9	X50.116.000	TAPPO CON ASTA LIVELLO OLIO L=465	FILLING PLUG WITH DIPSTICK	1	
10	X50.122.000	TUBO DI CARICO OLIO L=451	FILLING PIPE L=451	1	

K.LUBR.50.T01 (Blitz 45-50-55 - Maxi 600)

N°	Doc. Number	Titolo	Title	Q.tà	Note
1	X20.790.000	TUBO DI SCARICO OLIO 3/8" CIL. - 3/8" CON.	DRAIN PIPE 3/8"	1	
2	X40.266.000	TAPPO SCARICO OLIO M12x1,5	OIL EXHAUSTPLUG	1	
3	X02.013.000	TAPPO CIMA G 1/4" F.	PLUG G 1/4"	1	
4	X00.414.100	PORTAGOMMA D.11 1/4" M. FORATO	STRAIGHT HOSE D.11 1/4" WITH BLEED	1	
5	X02.355.000	FASCETTA D'ASSEMBLAGGIO 235 mm	NYLON ASSEMBLY CLAMP	1	
6	X02.217.015	TUBO D. 8x13 L= 150	HOSE D. 8x13 L= 150	1	
7	XFC.014,5.016	FASCETTA COBRA SLO30716	KOBRA CLAMP	1	
8	X20.792.000	PORTAGOMMA D.11 G 1/4" M. PER SFIATO	STRAIGHT HOSE D.11 G 1/4" FOR BREATHER	1	
9	X40.269.000	TAPPO CON ASTA LIVELLO L=215	FILLIG PLUG WITH DIPSTICK L=215	1	
10	X40.272.000	TUBO CARICAMENTO L=201	FILLING PIPE L=201	1	

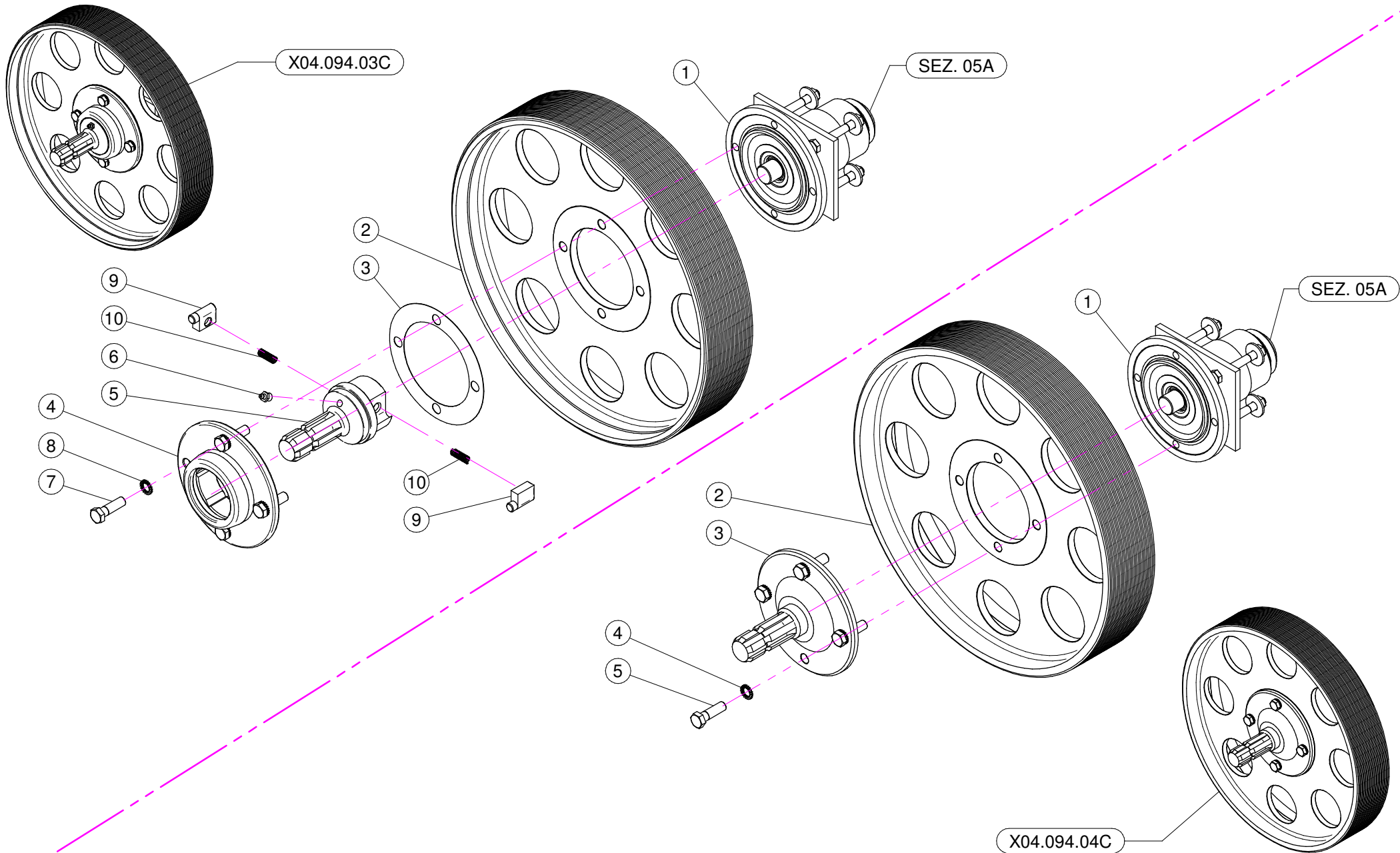

X04.094.03C

N°	Doc. Number	Titolo	Title	Q.tà	Note
1	X04.094.01C	SUPPORTO INFERIORE P40 - P/T45 - LP/TP45	CLUTCH	1	
2	X00.450.J32	PULEGGIA DI COMANDO 450J32	PULLEY	1	
3	X04.719.000	GUARNIZIONE RUOTA LIBERA	GASKET	1	
4	X04.066.000	CORPO ESTERNO RUOTA LIBERA	BODY	1	
5	X03.701.000	ROTORE RUOTA LIBERA	ROTOR	1	
6	XID.010.001	INGRASSATORE DIRITTO M10X1	GREASE NIPPLE	1	
7	XTE.012.040F	VITE M12X40	BOLT M12X40	4	
8	XRD.012.000	RONDELLA DENTELLATA D.12	TAB WASHER D.12	4	
9	X02.502.002	MARTELLETTO RUOTA LIBERA	PIN	2	
10	X02.502.001	MOLLA A COMPRESSIONE	SPRING	2	

X04.094.04C

N°	Doc. Number	Titolo	Title	Q.tà	Note
1	X04.094.01C	SUPPORTO INFERIORE P40 - P/T45 - LP/TP45	CLUTCH	1	
2	X00.450.J32	PULEGGIA DI COMANDO 450J32	PULLEY	1	
3	X04.707.100	ALBERO SCANALATO PER P.D.P.	SHAFT	1	
4	XRD.012.000	RONDELLA DENTELLATA D.12	TAB WASHER D.12	4	
5	XTE.012.040F	VITE M12X40	BOLT M12X40	4	

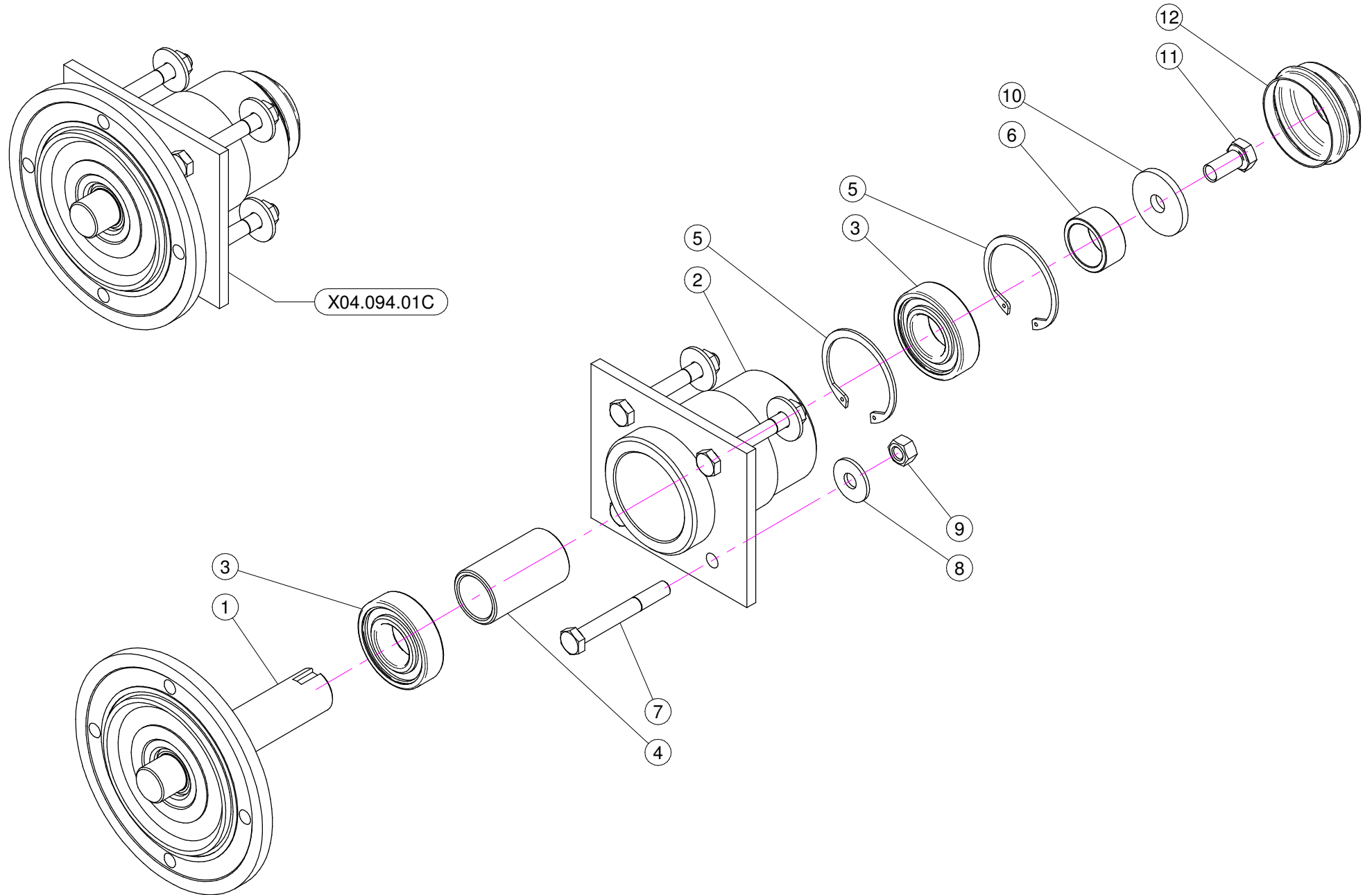

N°	Doc. Number	Titolo	Title	Q.tà	Note
1	X04.085.000	ALBERO INFERIORE	SHAFT	1	
2	X04.094.000	SUPPORTO INFERIORE	CLUTCH	1	
3	XK6.206.2RS	CUSCINETTO	BEARING	2	
4	X04.060.000	DISTANZIALE PER ALBERO INFERIORE	SPACER	1	
5	XI0.062.000	ANELLO ELASTICO INTERNO D. 62	INTERNAL D. 62 CIRCLIP	2	
6	X04.590.000	DISTANZIALE PER ALBERO INFERIORE	SPACER	1	
7	XTE.010.080	VITE TE M10 x 80	SCREW TE M10 x 80	4	
8	XRP.010.030	RONDELLA PIANA D.10 x 30 mm	WASHER D.10 x 30 mm	4	
9	XD0.10.5587G	DADO M10	NUT M10	4	
10	X20.810.000	RONDELLA SPECIALE PER SUPPORTO INFERIORE	SPECIAL WASHER FOR LOWER SUPPORT	1	
11	XTE.012.025FT	VITE TE 12X25	BOLT TE M12X1.25	1	
12	X04.062.001	COPERCHIETTO DI CHIUSURA	COVER	1	

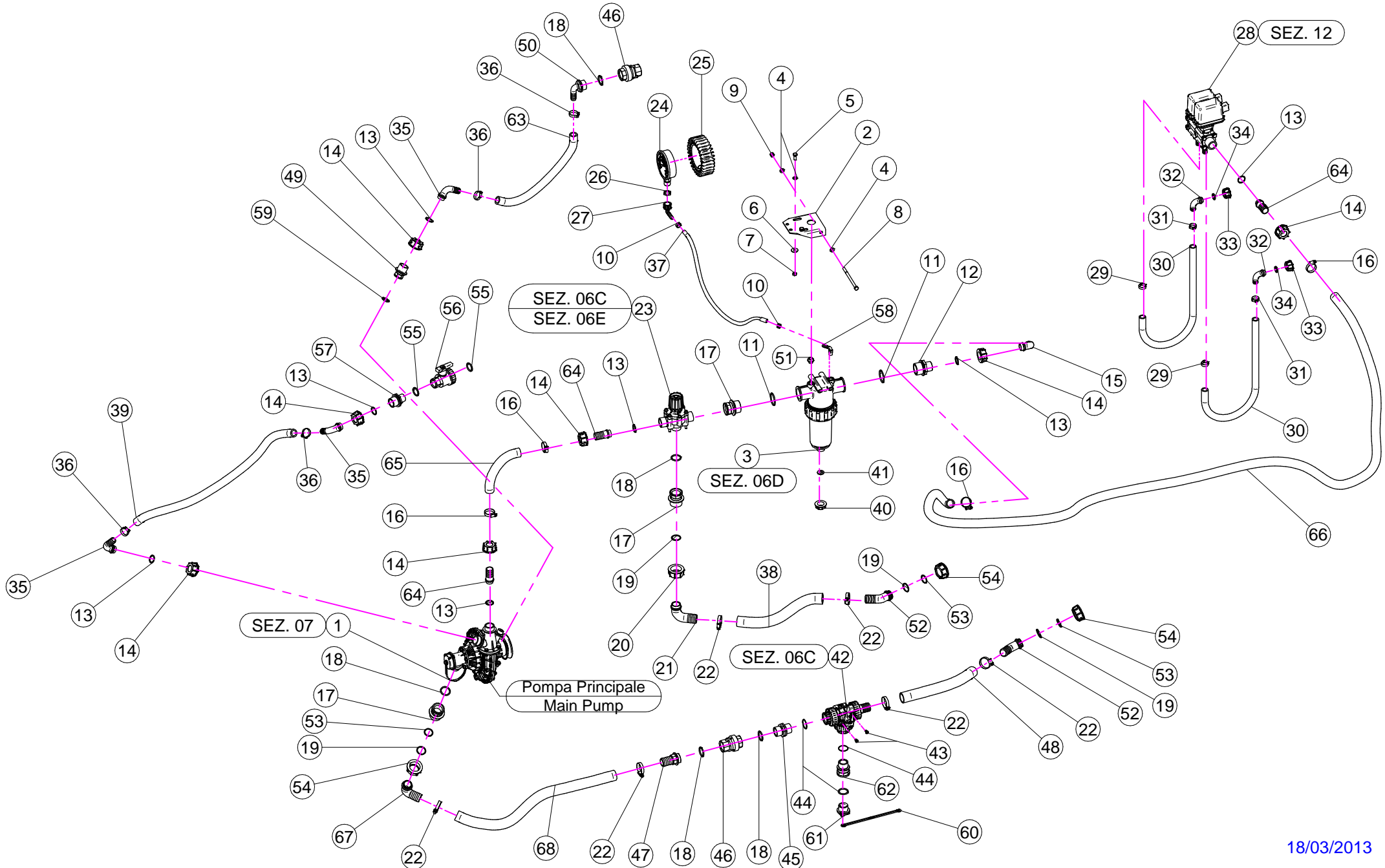

N°	Doc. Number	Titolo	Title	Q.tà	N°	Doc. Number	Titolo	Title	Q.tà
1	X02.157.071	POMPA COMPLETA	PUMP	1	35	X00.055.038	RACCORDO CURVO A P.G. D.19	CURVED UNION WITH R.H. D.19	3
2	X20.519.100	STAFFA FISSAGGIO GRUPPO REGOLAZIONE	BRACKET	1	36	XFC.027.5.029	FASCETTA COBRA 27,08 - W8	KOBRA CLAMP 27,08 - W8	4
3	X02.450.110	FILTRO IN LINEA F. 1" 1/4	LINE FILTER 1" 1/4 FEMALE	1	37	X02.217.040	TUBO D. 8x13 L= 400	HOSE D. 8x13 L= 400	1
4	XRP.008.000	RONDELLA PIANA D.8	WASHER D.8	4	38	X02.238.055	TUBO D. 30x41 L= 550	HOSE D. 30x41 L= 550	1
5	XTE.008.025T	VITE TE 8X25	SCREW TE M8X25	2	39	X02.212.100	TUBO D. 19x28 L= 1000	HOSE D. 19x28 L= 1000	1
6	XRP.008.024	RONDELLA PIANA LARGA D.8X24	WASHER D.8X24	2	40	X02.182.000	TAPPO 3/4" FEMMINA	FEMALE 3/4" CAP	1
7	XD0.08.5588G	DADO M8 6S PG	M8 6S BIG LEAD NUT 5588	2	41	X02.030.010	GUARNIZIONE TAPPO DISTRIBUTORE	GASKET	1
8	XTE.008.130	VITE TE M8 x 130	SCREW M8 x 130	1	42	X21.058.300	VALVOLA 3 VIE A SFERA CON 1 PG D.30	THREE WAYS VALVE	1
9	XDA.008.0AG	DADO AUTOBLOCCANTE M8	SELF LOCKING NUT M8	1	43	XTA.006.012P	VITI PER MAT. PLASTICI M6 x 12	SCREW M6 x 12	2
10	XFC.013.5.015	FASCETTA COBRA SLO30710	KOBRA CLAMP	2	44	XOR.002.125	OR D.31,47 x 1,78	31,47 x 1,78 O-RING GASKET	2
11	XOR.000.144	OR D.39,69x3,53	O-RING D.39,69x3,53	2	45	X00.055.034	NIPPLO 1" / 1" GAS	NIPPLE 1" / 1" GAS	1
12	X00.045.012	RIDUZIONE 1" 1/4 M - 1" M	1" 1/4 M - 1" M REDUCER NIPPLE	1	46	X21.149.000	VALVOLA DI RITEGNO 1" F.-F.	VALVE 1" F.-F.	2
13	XOR.000.132	OR D.23,81 x 2,62	23,81 x 2,62 O-RING GASKET	7	47	X00.422.100	RACCORDO DIRITTO PG 30 FIL.1" GAS TORNITO	MALE CONNECTOR RH 30 1" GAS	1
14	X00.055.24.2	GIRELLO 1" GAS	1" FLY NUT	7	48	X02.238.120	TUBO D. 30x38 L= 1200	HOSE D. 30x38 L= 1200	1
15	X00.055.037	RACCORDO CURVO P.G. D.25	D.25 HOSETAIL	1	49	X21.186.000	RIDUZIONE 1" M - 1/2" F	REDUCER NIPPLE 1" M - 1/2" F	1
16	XF0.023.035I	FASCETTA A VITE 23/35 W4 INOX	STAINLESS STEEL CLIP	4	50	X21.193.000	RACCORDO CURVO 90° 1" P.G.	HOSETAIL 90° 1" R.H.	1
17	X02.374.000	RIDUZIONE M/F 1" F / 1"1/4M	M. / F. 1" F / 1"1/4M REDUCTION	3	51	XTM.014.000	TAPPO MASCHIO 1/4"	MALE PLUG 1/4"	1
18	XOR.004.118	OR D.29,75 x 3,53	29,75 x 3,53 O-RING GASKET	6	52	X02.339.000	RACCORDO CURVO A 45° CON P.G. D.30	45° HOSETAIL	2
19	XOR.003.112	OR D.28,24x2,62	O-RING D.28,24x2,62	4	53	XOR.003.106	OR D.26.65x2.62	O-RING D.26.65x2.62	3
20	X00.058.006	GIRELLO 1" 1/4 GAS	1" 1/4 FLY NUT	1	54	X00.493.000	GIRELLO 1" 1/4 GAS	1" 1/4 FLY NUT	3
21	X00.058.004	RACCORDO CURVO P.G. D.30	D.30 HOSETAIL	1	55	XOR.000.134	OR D.25,8x3,53	O-RING D.25,8x3,53	2
22	XF0.025.040I	FASCETTA A VITE 25/40 W4 INOX	STAINLESS STEEL CLIP	6	56	X02.395.000	RUBINETTO 3/4" GAS F.F. SFERA	VALVE 3/4" GAS F.F. BALL	1
23	X02.447.000	VALVOLA A 3 VIE	3 WAY VALVE	1	57	X02.293.000	RIDUZIONE 1" M - 3/4" M	1" M - 3/4" M REDUCER NIPPLE	1
24	X02.445.000	MANOMETRO D.100 INOX 0-6 BAR	PRESSURE GAUGE Ø100 INOX 0-6 BAR	1	58	X21.084.000	RACCORDO 90° WES 8 / R1/4	HOSETAIL 90° WES 8 / R1/4	1
25	X02.470.000	CUFFIA PER MANOMETRO D.100	PRESSURE GAUGE GUARD	1	59	XOR.004.081	OR D.20,22 x 3,53	20,22 x 3,53 O-RING GASKET	1
26	X24.072.000	GHIERA IN OTTONE 1/2"	BRASS FLY NUT 1/2"	1	60	X21.183.000	STRISCIA FERMATAPPI	CAP STOP	1
27	X21.012.000	RACCORDO CURVO PG D. 12 G. 1/2"	D. 12 HOSETAIL	1	61	X21.182.000	TAPPO 1" M	PACKING 1" M	1
28	X02.390.08C	ELETTROVALVOLE	ELECTROVALVES	1	62	X02.384.000	RIDUZIONE 1" M - 1" F	1" M - 1" F REDUCER NIPPLE	1
29	XFC.021.5.023	FASCETTA COBRA 21,5 - 23	KOBRA CLAMP 21,5 - 23	2	63	X02.212.100	TUBO D. 19 L= 1000	HOSE D. 19 L= 1000	1
30	X02.211.110	TUBO D.16 L=1100	HOSE D.16 L=1100	2	64	X00.055.021	RACCORDO DIRITTO PG D.25	STRAIGHT HOSE R.H. D.25	3
31	XFC.023.5.025	FASCETTA COBRA 23,5 - 25	KOBRA CLAMP 23,5 - 25	2	65	X20.809.026	TUBO D.25x32 CON RAMINO L=260	HOSE D.25x32 L=260	1
32	X00.055.046	RACCORDO CURVO P.G. D.17	CURVED UNION WITH R.H. D.17	2	66	X20.770.287	TUBO SPIRALATO D.25 L=2870	HOSE D.25 L=2870	1
33	X00.055.045	GIRELLO 3/4" GAS	3/4" FLY NUT	2	67	X00.483.000	RACCORDO CURVO PG 30 1-1/4"	D.30 1-1/4" HOSETAIL	1
34	X02.349.000	GUARNIZIONE PIANA D.17X23X3	17X23X3 FLAT GASKET	2	68	X20.852.070	TUBO D.30 CON RAMINO L=700	HOSE D.30 L=700	1

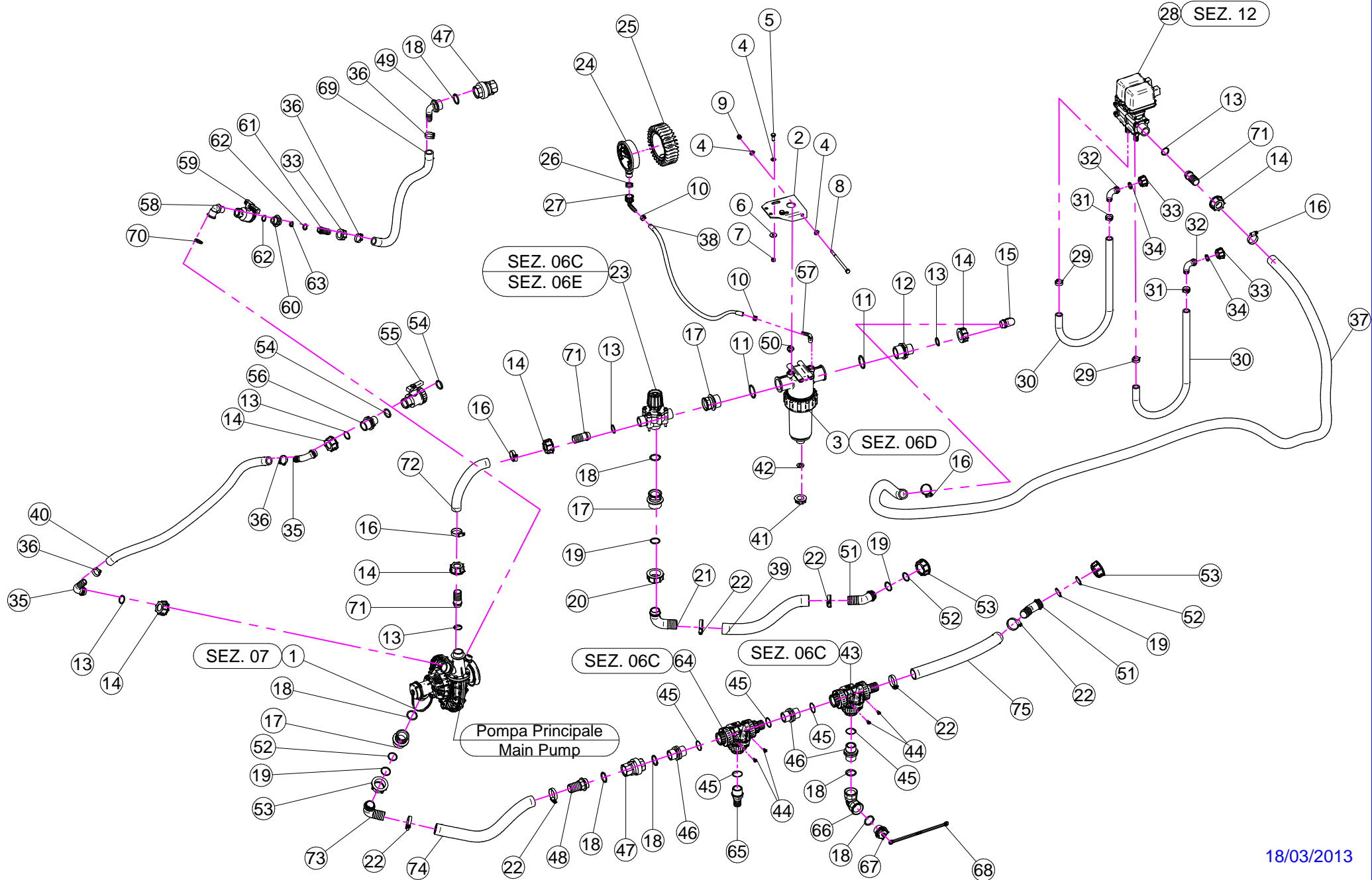

N°	Doc. Number	Titolo	Title	Q.tà	N°	Doc. Number	Titolo	Title	Q.tà
1	X02.157.071	POMPA COMPLETA	PUMP	1	39	X02.238.055	TUBO D. 30x41 L= 550	HOSE D. 30x41 L= 550	1
2	X20.519.100	STAFFA FISSAGGIO GRUPPO REGOLAZIONE	BRACKET	1	40	X02.212.100	TUBO D. 19x28 L= 1000	HOSE D. 19x28 L= 1000	1
3	X02.450.110	FILTRO IN LINEA F. 1" 1/4	LINE FILTER 1" 1/4 FEMALE	1	41	X02.182.000	TAPPO 3/4" FEMMINA	FEMALE 3/4" CAP	1
4	XRP.008.000	RONDELLA PIANA D.8	WASHER D.8	4	42	X02.030.010	GUARNIZIONE TAPPO DISTRIBUTORE	GASKET	1
5	XTE.008.025T	VITE TE 8X25	SCREW TE M8X25	2	43	X21.058.300	VALVOLA 3 VIE A SFERA CON 1 PG D.30	THREE WAYS VALVE	1
6	XRP.008.024	RONDELLA PIANA LARGA D.8X24	WASHER D.8X24	2	44	XTA.006.012P	VITI PER MAT. PLASTICI M6 x 12	SCREW M6 x 12	4
7	XD0.08.5588G	DADO M8 6S PG	M8 6S BIG LEAD NUT 5588	2	45	XOR.002.125	OR D.31,47 x 1,78	31,47 x 1,78 O-RING GASKET	5
8	XTE.008.130	VITE TE M8 x 130	SCREW M8 x 130	1	46	X00.055.034	NIPPLO 1" / 1" GAS	NIPPLE 1" / 1" GAS	3
9	XDA.008.0AG	DADO AUTOBLOCCANTE M8	SELF LOCKING NUT M8	1	47	X21.149.000	VALVOLA DI RITEGNO 1" F.-F.	VALVE 1" F.-F.	2
10	XFC.013.5.015	FASCETTA COBRA SLO30710	KOBRA CLAMP	2	48	X00.422.100	RACCORDO DIRITTO PG 30 FIL.1" GAS TORNITO	MALE CONNECTOR RH 30 1" GAS	1
11	XOR.000.144	OR D.39,69x3,53	O-RING D.39,69x3,53	2	49	X21.193.000	RACCORDO CURVO 90° 1" P.G.	HOSETAIL 90° 1" R.H.	1
12	X00.045.012	RIDUZIONE 1" 1/4 M - 1" M	1" 1/4 M - 1" M REDUCER NIPPLE	1	50	XTM.014.000	TAPPO MASCHIO 1/4"	MALE PLUG 1/4"	1
13	XOR.000.132	OR D.23,81 x 2,62	23,81 x 2,62 O-RING GASKET	6	51	X02.339.000	RACCORDO CURVO A 45° CON P.G. D.30	45° HOSETAIL	2
14	X00.055.24.2	GIRELLO 1" GAS	1" FLY NUT	6	52	XOR.003.106	OR D.26.65x2.62	O-RING D.26.65x2.62	3
15	X00.055.037	RACCORDO CURVO P.G. D.25	D.25 HOSETAIL	1	53	X00.493.000	GIRELLO 1" 1/4 GAS	1" 1/4 FLY NUT	3
16	XF0.023.035I	FASCETTA A VITE 23/35 W4 INOX	STAINLESS STEEL CLIP	4	54	XOR.000.134	OR D.25,8x3,53	O-RING D.25,8x3,53	2
17	X02.374.000	RIDUZIONE M/F 1" F / 1"1/4M	M. / F. 1" F / 1"1/4M REDUCTION	3	55	X02.395.000	RUBINETTO 3/4" GAS F.F. SFERA	VALVE 3/4" GAS F.F. BALL	1
18	XOR.004.118	OR D.29,75 x 3,53	29,75 x 3,53 O-RING GASKET	7	56	X02.293.000	RIDUZIONE 1" M - 3/4" M	1" M - 3/4" M REDUCER NIPPLE	1
19	XOR.003.112	OR D.28,24x2,62	O-RING D.28,24x2,62	4	57	X21.084.000	RACCORDO 90° WES 8 / R1/4	HOSETAIL 90° WES 8 / R1/4	1
20	X00.058.006	GIRELLO 1" 1/4 GAS	1" 1/4 FLY NUT	1	58	X21.180.000	CURVA 90° 1/2"M-1/2"F.	ELBOW 90° 1/2"M-1/2"F.	1
21	X00.058.004	RACCORDO CURVO P.G. D.30	D.30 HOSETAIL	1	59	X21.147.000	VALVOLA A SFERA 1/2" F/F	WAYS VALVE 1/2" F/F	1
22	XF0.025.040I	FASCETTA A VITE 25/40 W4 INOX	STAINLESS STEEL CLIP	6	60	X00.055.044	NIPPLO 1/2" GAS 3/4" GAS	NIPPLE 1/2" - 3/4" GAS	1
23	X02.447.000	VALVOLA A 3 VIE	3 WAY VALVE	1	61	X21.184.000	RACCORDO DIRITTO 3/4" P.G.20	STRAIGHT UNION 3/4" R.H.20	1
24	X02.445.000	MANOMETRO D.100 INOX 0-6 BAR	PRESSURE GAUGE Ø100 INOX 0-6 BAR	1	62	XOR.000.121	OR D. 15,88 x 2,62	15,88 x 2,62 O-RING GASKET	2
25	X02.470.000	CUFFIA PER MANOMETRO D.100	PRESSURE GAUGE GUARD	1	63	XOR.000.117	OR D. 13,1x18,34x2,62	13,1x18,34x2,62 O-RING GASKET	1
26	X24.072.000	GHIERA IN OTTONE 1/2"	BRASS FLY NUT 1/2"	1	64	X21.058.100	VALVOLA 3 VIE COMPLETA	THREE WAYS VALVE COMPLETE	1
27	X21.012.000	RACCORDO CURVO PG D. 12 G. 1/2"	D. 12 HOSETAIL	1	65	X02.403.000	RACCORDO DIRITTO PG D.25 - 1"	STRAIGHT HOSE R. H D.25 - 1"	1
28	X02.390.08C	ELETTROVALVOLE	ELECTROVALVES	1	66	X02.291.000	RACCORDO CURVO 1" FEMMINA	FEMALE HOSETAIL THREAD 1"	1
29	XFC.021.5.023	FASCETTA COBRA 21,5 - 23	KOBRA CLAMP 21,5 - 23	2	67	X21.182.000	TAPPO 1" M	PACKING 1" M	1
30	X02.211.110	TUBO D.16 L=1100	HOSE D.16 L=1100	2	68	X21.183.000	STRISCIA FERMATAPPI	CAP STOP	1
31	XFC.023.5.025	FASCETTA COBRA 23,5 - 25	KOBRA CLAMP 23,5 - 25	2	69	X02.212.080	TUBO D. 19 L= 800	HOSE D. 19 L= 800	1
32	X00.055.046	RACCORDO CURVO P.G. D.17	CURVED UNION WITH R.H. D.17	2	70	XOR.004.081	OR D.20,22 x 3,53	20,22 x 3,53 O-RING GASKET	1
33	X00.055.045	GIRELLO 3/4" GAS	3/4" FLY NUT	3	71	X00.055.021	RACCORDO DIRITTO PG D.25	STRAIGHT HOSE R.H D.25	3
34	X02.349.000	GUARNIZIONE PIANA D.17X23X3	17X23X3 FLAT GASKET	2	72	X20.809.026	TUBO D.25x32 CON RAMINO L=260	HOSE D.25x32 L=260	1
35	X00.055.038	RACCORDO CURVO A P.G. D.19	CURVED UNION WITH R.H. D.19	2	73	X00.483.000	RACCORDO CURVO PG 30 1-1/4"	D.30 1-1/4" HOSETAIL	1
36	XFC.026.5.028	FASCETTA COBRA 26,5 - 28	KOBRA CLAMP 26,5 - 28	4	74	X02.238.060	TUBO 30x38 L= 600	HOSE 30x38 L= 600	1
37	X20.770.287	TUBO D. 25x32 L= 2870	HOSE D. 25x32 L= 2870	1	75	X02.238.060	TUBO D. 30x38 L= 600	HOSE D. 30x38 L= 600	1
38	X02.217.040	TUBO D. 8x13 L= 400	HOSE D. 8x13 L= 400	1					

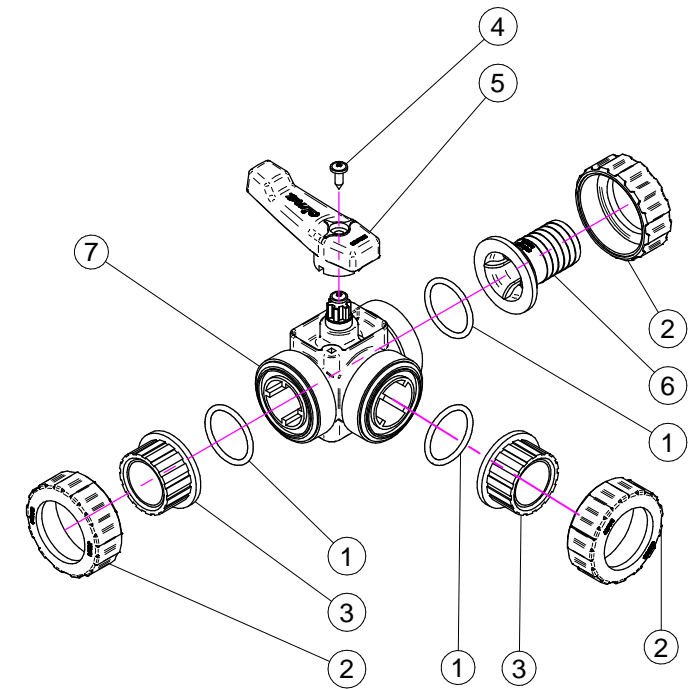
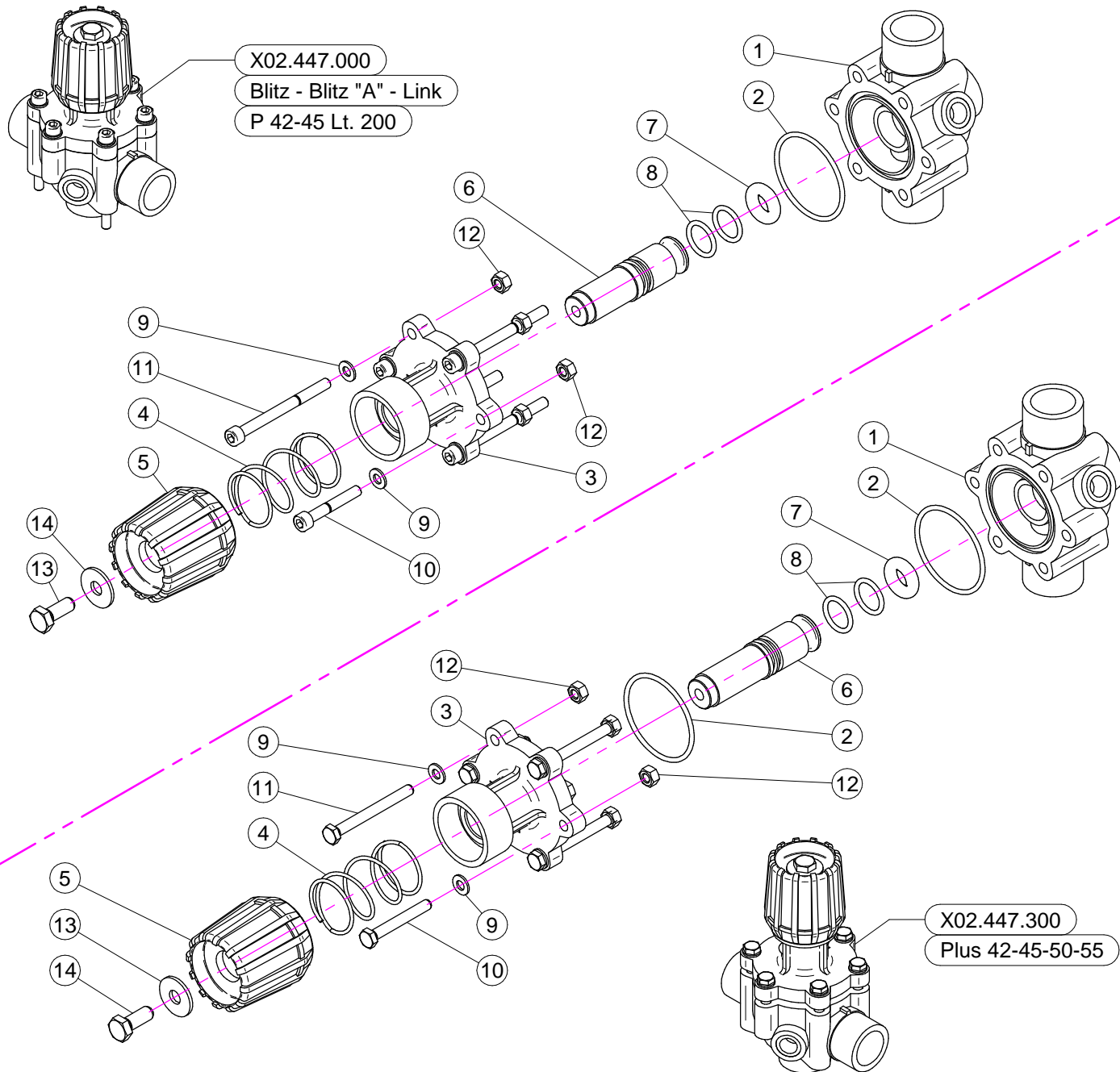

BLITZ - BLITZ "A" - LINK

N°	Doc. Number	Titolo	Title	Q.tà	Note
1	X02.447.001	CORPO VALVOLA DI REGOLAZIONE	BODY FOR REGULATION VALVE	1	
2	XOR.003.193	OR D.48,89x2,62	O-RING GASKET 48,89x2,62	1	
3	X02.447.009	FLANGIA SUPERIORE SERRANDA	UPPER FLANGE	1	
4	X02.447.011	MOLLA RECUPERO GIOCO	SPRING	1	
5	X02.447.010	MANOPOLA VALVOLA	REGULATION VALVE KNOB	1	
6	X02.447.014	PERNO PER REGOLATORE DI PRESSIONE	PIN	1	
7	X02.447.005	OR SPECIALE PER SERRANDA 2447	SPECIAL O-RING FOR GATE 2447	1	
8	XOR.003.068	OR D.17,12x2,62	O-RING GASKET 17,12x2,62	2	
9	XRP.006.000	RONDELLA PIANA D. 6	WASHER D.6	6	
10	XTCE.006.040	VITE BRUGOLA TCE M6x40	BOLT TCE M6x40	2	
11	XTCE.006.070	VITE BRUGOLA TCE M6x70	BOLT TCE M6x70	4	
12	XD0.06.5588G	DADO M6	NUT M6	6	
13	XTE.008.025I	VITE TE 8X25 INOX	INOX 8X25 SCREW	1	
14	XRP.008.024I	RONDELLA PIANA LARGA D.8X24 INOX	INOX WASHER D.8X24	1	

PLUS 42-45-50-55

N°	Doc. Number	Titolo	Title	Q.tà	Note
1	X02.447.001	CORPO VALVOLA DI REGOLAZIONE	BODY FOR REGULATION VALVE	1	
2	XOR.003.193	OR D.48,89x2,62	O-RING GASKET 48,89x2,62	2	
3	X02.447.012	FLANGIA SUPERIORE SERRANDA	UPPER FLANGE	1	
4	X02.447.011	MOLLA RECUPERO GIOCO	SPRING	1	
5	X02.447.010	MANOPOLA VALVOLA	REGULATION VALVE KNOB	1	
6	X02.447.013	PERNO IN NYLON PER VALVOLA	VALVE PIN	1	
7	X02.447.005	OR SPECIALE PER SERRANDA 2447	SPECIAL O-RING FOR GATE 2447	1	
8	XOR.003.068	OR D.17,12x2,62	O-RING GASKET 17,12x2,62	2	
9	XRP.006.000I	RONDELLA PIANA D. 6 INOX	INOX WASHER D.6	6	
10	XTE.006.045I	VITE TE M6x45 INOX	INOX M6x45 SCREW	2	
11	XTE.006.060I	VITE TE M6x60 INOX	INOX M6x60 TE SCREW	4	
12	XD0.06.5588GI	DADO M6 6S PG INOX	INOX M6 6S BIG LEAD NUT 5588	6	
13	XRP.008.024I	RONDELLA PIANA LARGA D.8X24 INOX	INOX WASHER D.8X24	1	
14	XTE.008.025I	VITE TE 8X25 INOX	INOX 8X25 SCREW	1	

N°	Doc. Number	Titolo	Title	Q.tà
1	XOR.004.137	OR D.34.52x3.53	O-RING D.34.52x3.53	3
2	X21.058.007	GHIERA VALVOLA 3 VIE	VALVE UNION NUT	3
3	X21.058.006	MANICOTTO VALVOLA 3 VIE	VALVE END CONNECTOR	2
4	XTA.05.5.016	VITE AUTOFILETTANTE M5,5 x 16	SELFTHREADED SCREW M5,5 x 16	1
5	X21.058.003	MANIGLIA VALVOLA 3 VIE	VALVE HANDLE	1
6	X21.058.009	PORTAGOMMA D.30 RUBINETTO A 3 VIE	RUBBER HOLDER D.30	1
7	X21.058.110	CORPO VALVOLA 3 VIE	BODY OF THREE WAYS VALVE	1

CODICE-CODE
X02.450.100

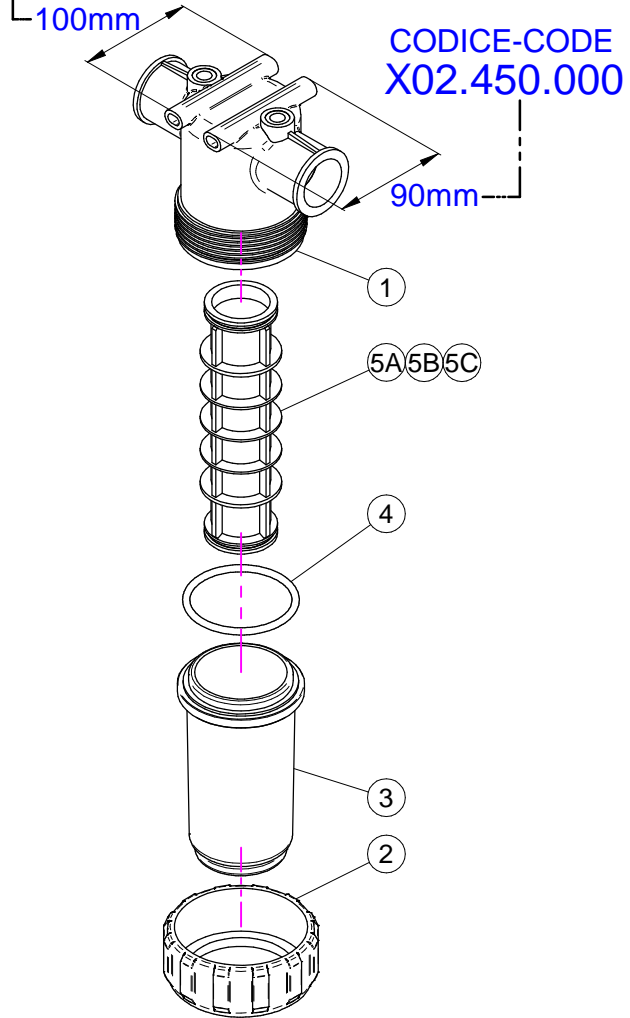

CODICE-CODE
X02.450.110

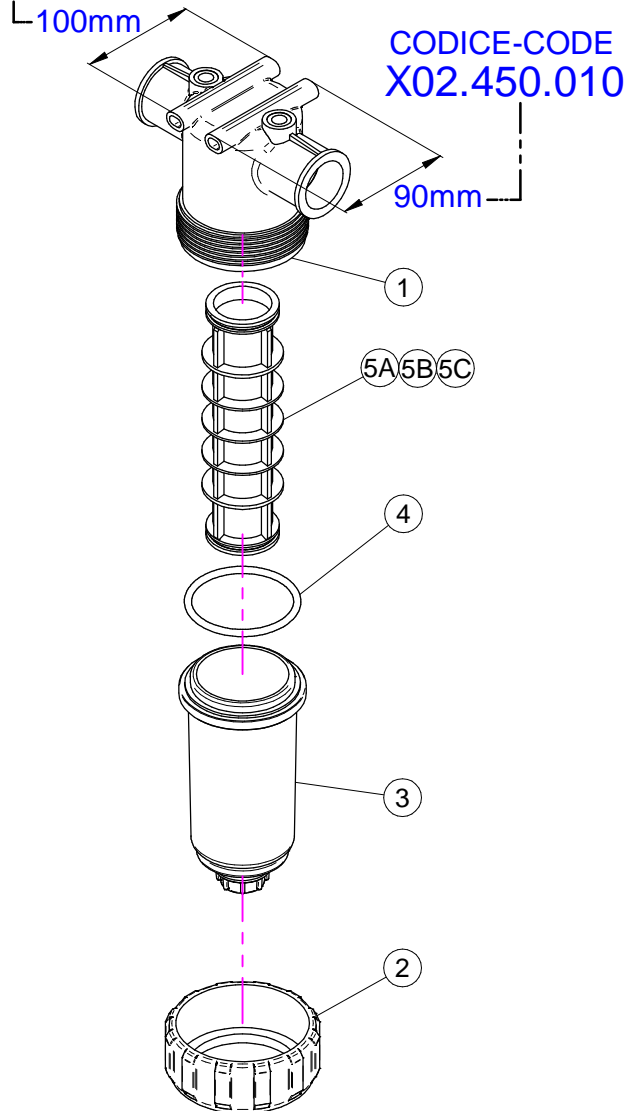

CODICE-CODE
X02.450.120

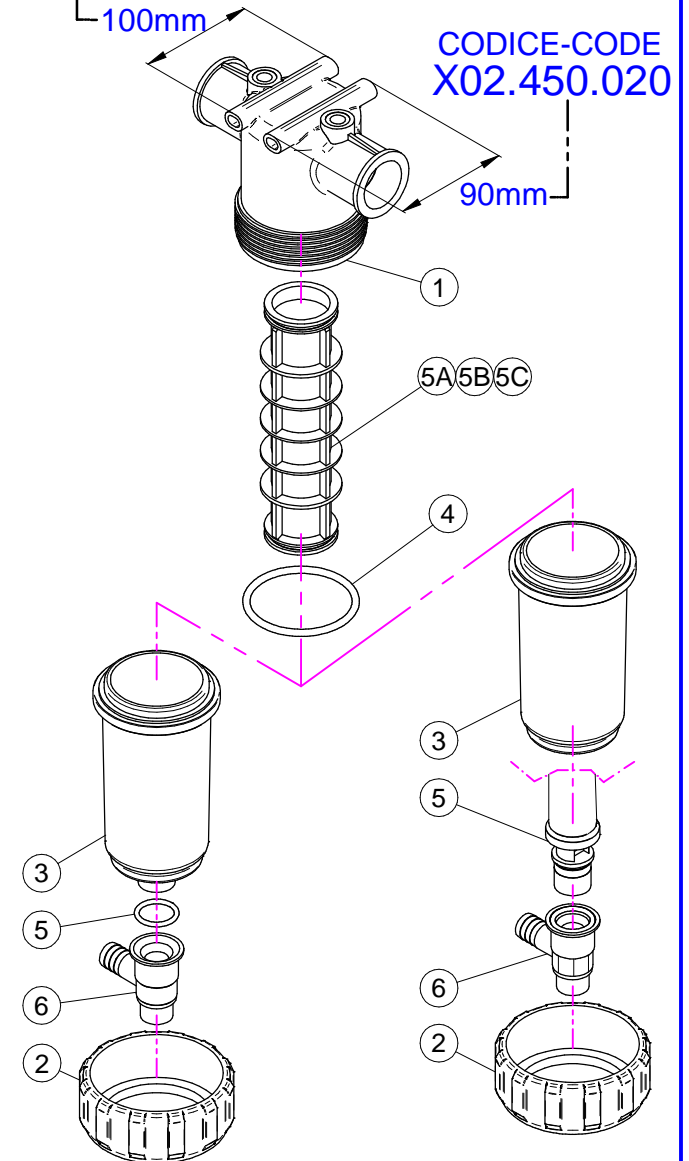

X02.450.100

N°	Doc. Number	Titolo	Title	Q.tà	Note
1	X02.450.101	CORPO FILTRO IN LINEA F. 1 1/4"	LINE FILTER BODY	1	
2	X02.450.003	GHIERA FILTRO IN LINEA	RING NUT FILTER IN LINE	1	
3	X02.450.002	COPERCHIO FILTRO	LID FILTER	1	
4	XOR.000.178	OR D.74,63x5,33	O-RING D.74,63x5,33	1	
5A	X02.450.004C	CARTUCCIA FILTRO CON OR 50 MESH (BLU)	CARTRIDGE WITH O-RING 50 MESH (BLUE)	1	
5B	X02.450.204C	CARTUCCIA FILTRO CON OR 80 MESH (GRIGIO)	CARTRIDGE WITH O-RING 80 MESH (GREY)	1	
5C	X02.450.104C	CARTUCCIA FILTRO CON OR 32 MESH (BIANCO)	CARTRIDGE WITH O-RING 32 MESH (WHITE)	1	

X02.450.000

N°	Doc. Number	Titolo	Title	Q.tà	Note
1	X02.450.001	CORPO FILTRO IN LINEA F. 1 1/4"	LINE FILTER BODY	1	
2	X02.450.003	GHIERA FILTRO IN LINEA	RING NUT FILTER IN LINE	1	
3	X02.450.002	COPERCHIO FILTRO	LID FILTER	1	
4	XOR.000.178	OR D.74,63x5,33	O-RING D.74,63x5,33	1	
5A	X02.450.004C	CARTUCCIA FILTRO CON OR 50 MESH (BLU)	CARTRIDGE WITH O-RING 50 MESH (BLUE)	1	
5B	X02.450.204C	CARTUCCIA FILTRO CON OR 80 MESH (GRIGIO)	CARTRIDGE WITH O-RING 80 MESH (GREY)	1	
5C	X02.450.104C	CARTUCCIA FILTRO CON OR 32 MESH (BIANCO)	CARTRIDGE WITH O-RING 32 MESH (WHITE)	1	

X02.450.110

N°	Doc. Number	Titolo	Title	Q.tà	Note
1	X02.450.101	CORPO FILTRO IN LINEA F. 1 1/4"	LINE FILTER BODY	1	
2	X02.450.003	GHIERA FILTRO IN LINEA	RING NUT FILTER IN LINE	1	
3	X02.450.011	COPERCHIO FILTRO CON SCARICO D.3/4"	LID FILTER WITH UNLOADING	1	
4	XOR.000.178	OR D.74,63x5,33	O-RING D.74,63x5,33	1	
5A	X02.450.004C	CARTUCCIA FILTRO CON OR 50 MESH (BLU)	CARTRIDGE WITH O-RING 50 MESH (BLUE)	1	
5B	X02.450.204C	CARTUCCIA FILTRO CON OR 80 MESH (GRIGIO)	CARTRIDGE WITH O-RING 80 MESH (GREY)	1	
5C	X02.450.104C	CARTUCCIA FILTRO CON OR 32 MESH (BIANCO)	CARTRIDGE WITH O-RING 32 MESH (WHITE)	1	

X02.450.010

N°	Doc. Number	Titolo	Title	Q.tà	Note
1	X02.450.001	CORPO FILTRO IN LINEA F. 1 1/4"	LINE FILTER BODY	1	
2	X02.450.003	GHIERA FILTRO IN LINEA	RING NUT FILTER IN LINE	1	
3	X02.450.011	COPERCHIO FILTRO CON SCARICO D.3/4"	LID FILTER WITH UNLOADING	1	
4	XOR.000.178	OR D.74,63x5,33	O-RING D.74,63x5,33	1	
5A	X02.450.004C	CARTUCCIA FILTRO CON OR 50 MESH (BLU)	CARTRIDGE WITH O-RING 50 MESH (BLUE)	1	
5B	X02.450.204C	CARTUCCIA FILTRO CON OR 80 MESH (GRIGIO)	CARTRIDGE WITH O-RING 80 MESH (GREY)	1	
5C	X02.450.104C	CARTUCCIA FILTRO CON OR 32 MESH (BIANCO)	CARTRIDGE WITH O-RING 32 MESH (WHITE)	1	

X02.450.120

N°	Doc. Number	Titolo	Title	Q.tà	Note
1	X02.450.101	CORPO FILTRO IN LINEA F. 1 1/4"	LINE FILTER BODY	1	
2	X02.450.003	GHIERA FILTRO IN LINEA	RING NUT FILTER IN LINE	1	
3	X02.450.011	COPERCHIO FILTRO CON SCARICO D.3/4"	LID FILTER WITH UNLOADING	1	
4	XOR.000.178	OR D.74,63x5,33	O-RING D.74,63x5,33	1	
5	XOR.000.134	OR D.25,8x3,53	O-RING D.25,8x3,53	1	
6	X02.450.120.D	RUBINETTO AUTOPULENTE PER FILTRO	FAUCET FOR FILTER	1	
7A	X02.450.004C	CARTUCCIA FILTRO CON OR 50 MESH (BLU)	CARTRIDGE WITH O-RING 50 MESH (BLUE)	1	
7B	X02.450.204C	CARTUCCIA FILTRO CON OR 80 MESH (GRIGIO)	CARTRIDGE WITH O-RING 80 MESH (GREY)	1	
7C	X02.450.104C	CARTUCCIA FILTRO CON OR 32 MESH (BIANCO)	CARTRIDGE WITH O-RING 32 MESH (WHITE)	1	

X02.450.020

N°	Doc. Number	Titolo	Title	Q.tà	Note
1	X02.450.001	CORPO FILTRO IN LINEA F. 1 1/4"	LINE FILTER BODY	1	
2	X02.450.003	GHIERA FILTRO IN LINEA	RING NUT FILTER IN LINE	1	
3	X02.450.020.A	COPERCHIO FILTRO IN LINEA 1" 1/4	LINE FILTER LID 1" 1/4	1	
4	XOR.000.178	OR D.74,63x5,33	O-RING D.74,63x5,33	1	
5	X02.450.020.B	CORPO CENTRALE CON TAPPO 1" 1/4	CENTRAL BODY WITH CAP 1" 1/4	1	
6	X02.450.020.D	RUBINETTO AUTOPULENTE PER FILTRO	FAUCET FOR FILTER	1	
7A	X02.450.004C	CARTUCCIA FILTRO CON OR 50 MESH (BLU)	CARTRIDGE WITH O-RING 50 MESH (BLUE)	1	
7B	X02.450.204C	CARTUCCIA FILTRO CON OR 80 MESH (GRIGIO)	CARTRIDGE WITH O-RING 80 MESH (GREY)	1	
7C	X02.450.104C	CARTUCCIA FILTRO CON OR 32 MESH (BIANCO)	CARTRIDGE WITH O-RING 32 MESH (WHITE)	1	

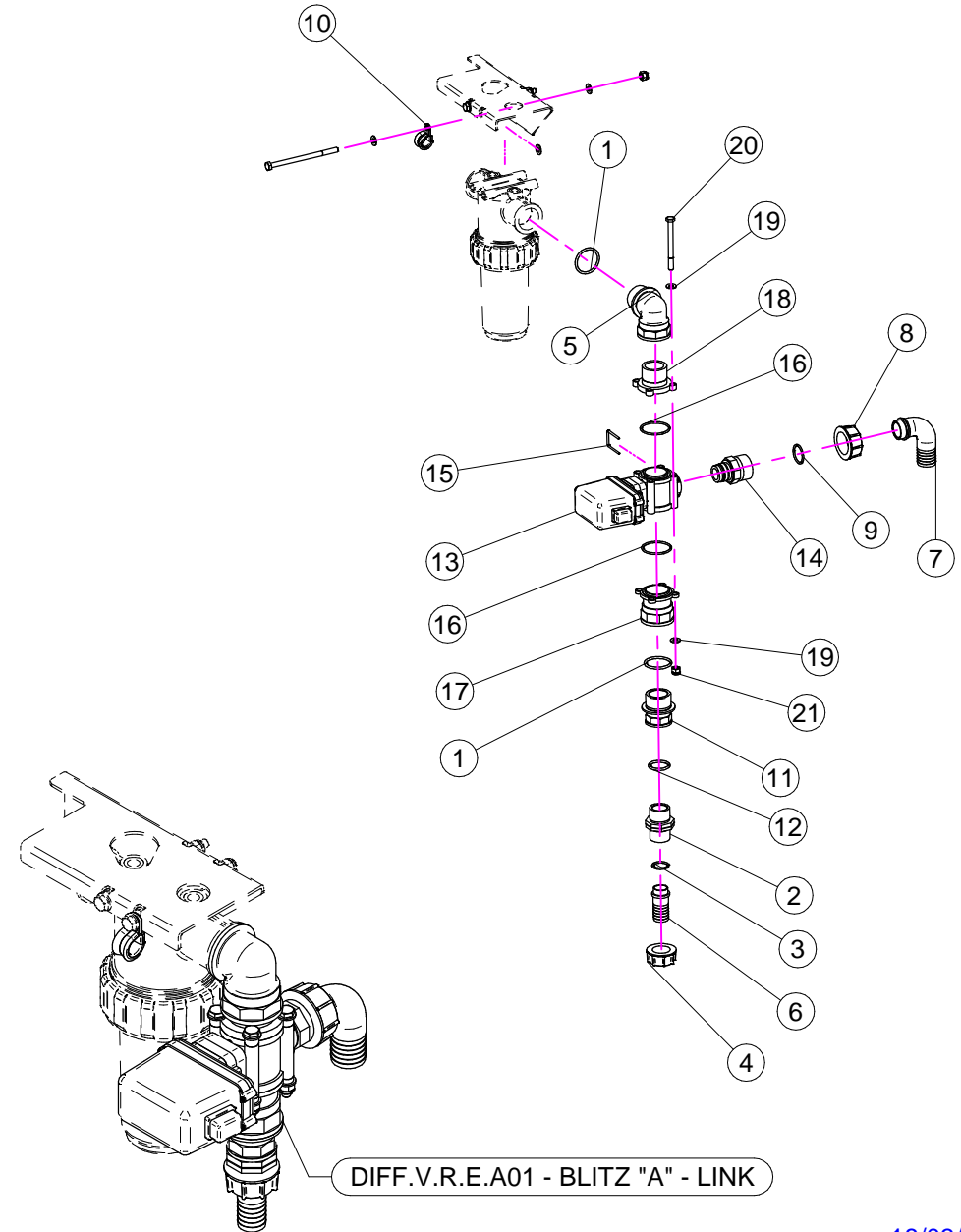
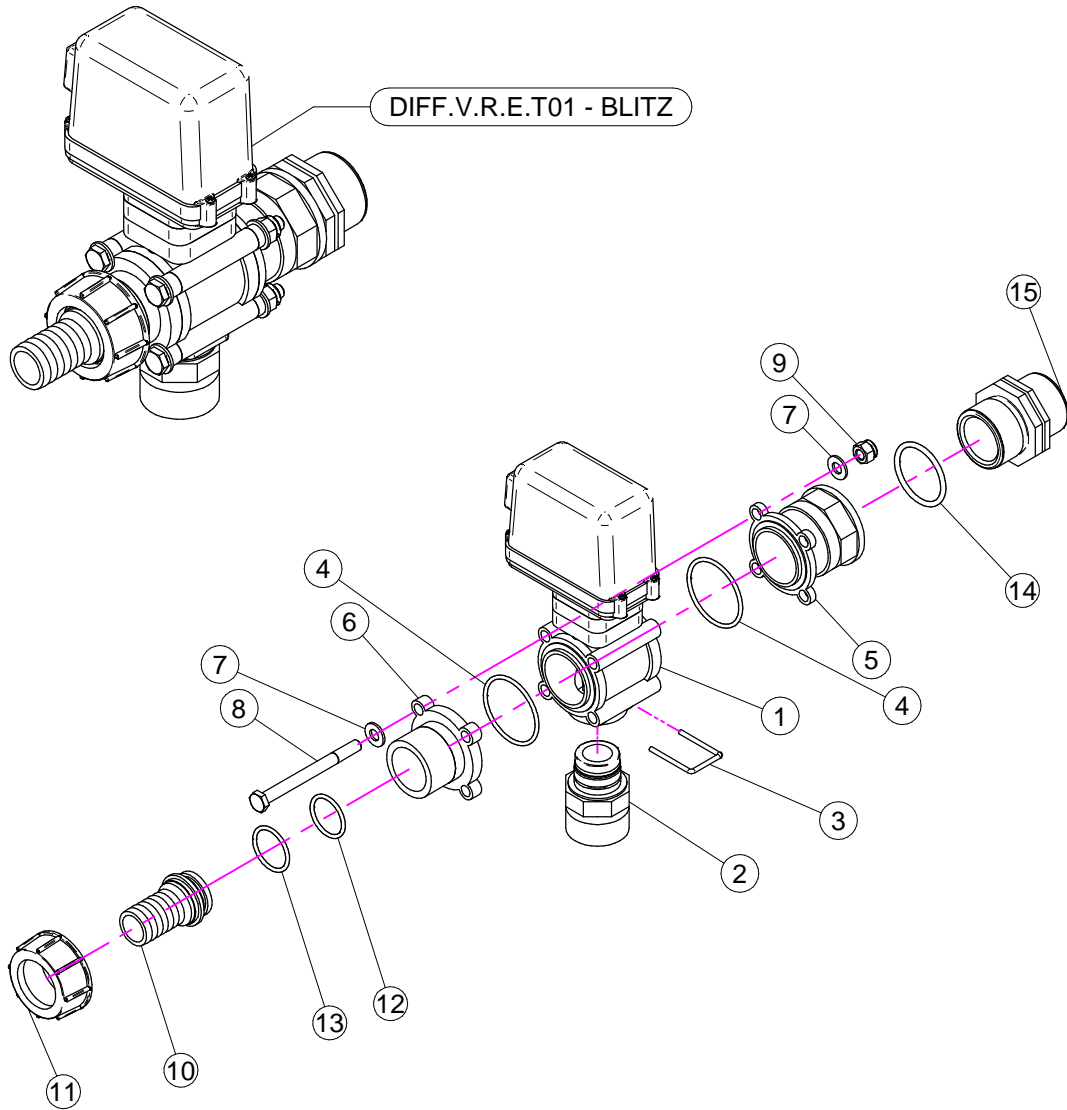

DIFF.V.R.E.T01
BLITZ

N°	Doc. Number	Titolo	Title	Q.tà	Note
1	X21.130.000	VALVOLA MOTORIZZATA PROPORZIONALE	ELECTRIC PROPORTIONAL VALVE	1	
2	X21.131.000	RIDUZIONE ATT.RAP. G 1" 1/4	REDUCTION J. F. G 1" 1/4	1	
3	X21.130.005	FORCHETTA ATTACCO RAPIDO	FORK FASTNER JOINT	1	
4	XOR.003.181	OR D. 45,69x50,93x2,62	45,69x50,93x2,62 O-RING	2	
5	X21.133.000	RACCORDO FLANGIATO 1" - 1 1/4"	CONNECTOR	1	
6	X21.132.000	FLANGIA VALVOLE	VALVE FLANGE	1	
7	XRP.008.000	RONDELLA PIANA D.8	WASHER D.8	8	
8	XTE.008.090	VITE TE M8 x 90	SCREW TE M8 x 90	4	
9	XDA.008.0AG	DADO AUTOBLOCCANTE M8	SELF LOCKING NUT M8	4	
10	X02.363.000	RACCORDO DIRITTO PG D.25 - 1 1/4	STRAIGHT HOSE R.H D.25 - 1 1/4	1	
11	X00.058.006	GIRELLO 1" 1/4 GAS	1" 1/4 FLY NUT	1	
12	XOR.003.106	OR D.26.65x2.62	O-RING D.26.65x2.62	1	
13	XOR.003.112	OR D.28,24x2,62	O-RING D.28,24x2,62	1	
14	XOR.000.144	OR D.39,69x3,53	O-RING D.39,69x3,53	1	
15	X00.345.010	NIPPLO 1" 1/4 + 1" 1/4 GAS	NIPPLE 1" 1/4 + 1" 1/4 GAS	1	

DIFF.V.R.E.A01
BLITZ "A" - LINK

N°	Doc. Number	Titolo	Title	Q.tà	Note
1	XOR.000.144	OR D.39,69x3,53	O-RING D.39,69x3,53	2	
2	X00.055.034	NIPPLO 1" / 1" GAS	NIPPLE 1" / 1" GAS	1	
3	XOR.000.132	OR D.23,81 x 2,62	23,81 x 2,62 O-RING GASKET	1	
4	X00.055.24.2	GIRELLO 1" GAS	1" FLY NUT	1	
5	X24.070.000	RACCORDO CURVO M-F 1"1/4	HOSETAIL 1"1/4	1	
6	X00.055.021	RACCORDO DIRITTO PG D.25	STRAIGHT HOSE R.H D.25	1	
7	X00.058.004	RACCORDO CURVO P.G. D.30	D.30 HOSETAIL	1	
8	X00.058.006	GIRELLO 1" 1/4 GAS	1" 1/4 FLY NUT	1	
9	XOR.003.112	OR D.28,24x2,62	O-RING D.28,24x2,62	1	
10	XFG.018.000	FASCETTA GOMMATA PER TUBI D.18	STICKER	1	
11	X02.374.000	RIDUZIONE M/F 1"F / 1"1/4M	M. / F. 1"F / 1"1/4M REDUCTION	1	
12	XOR.004.118	OR D.29,75 x 3,53	29,75 x 3,53 O-RING GASKET	1	
13	X21.130.000	VALVOLA MOTORIZZATA PROPORZIONALE	ELECTRIC PROPORTIONAL VALVE	1	
14	X21.131.000	RIDUZIONE ATT.RAP. G 1" 1/4	REDUCTION J. F. G 1" 1/4	1	
15	X21.130.005	FORCHETTA ATTACCO RAPIDO	FORK FASTNER JOINT	1	
16	XOR.003.181	OR D. 45,69x50,93x2,62	45,69x50,93x2,62 O-RING	2	
17	X21.133.000	RACCORDO FLANGIATO 1" - 1 1/4"	CONNECTOR	1	
18	X21.132.000	FLANGIA VALVOLE	VALVE FLANGE	1	
19	XRP.008.000	RONDELLA PIANA D.8	WASHER D.8	8	
20	XTE.008.090	VITE TE M8 x 90	SCREW TE M8 x 90	4	
21	XDA.008.0AG	DADO AUTOBLOCCANTE M8	SELF LOCKING NUT M8	4	

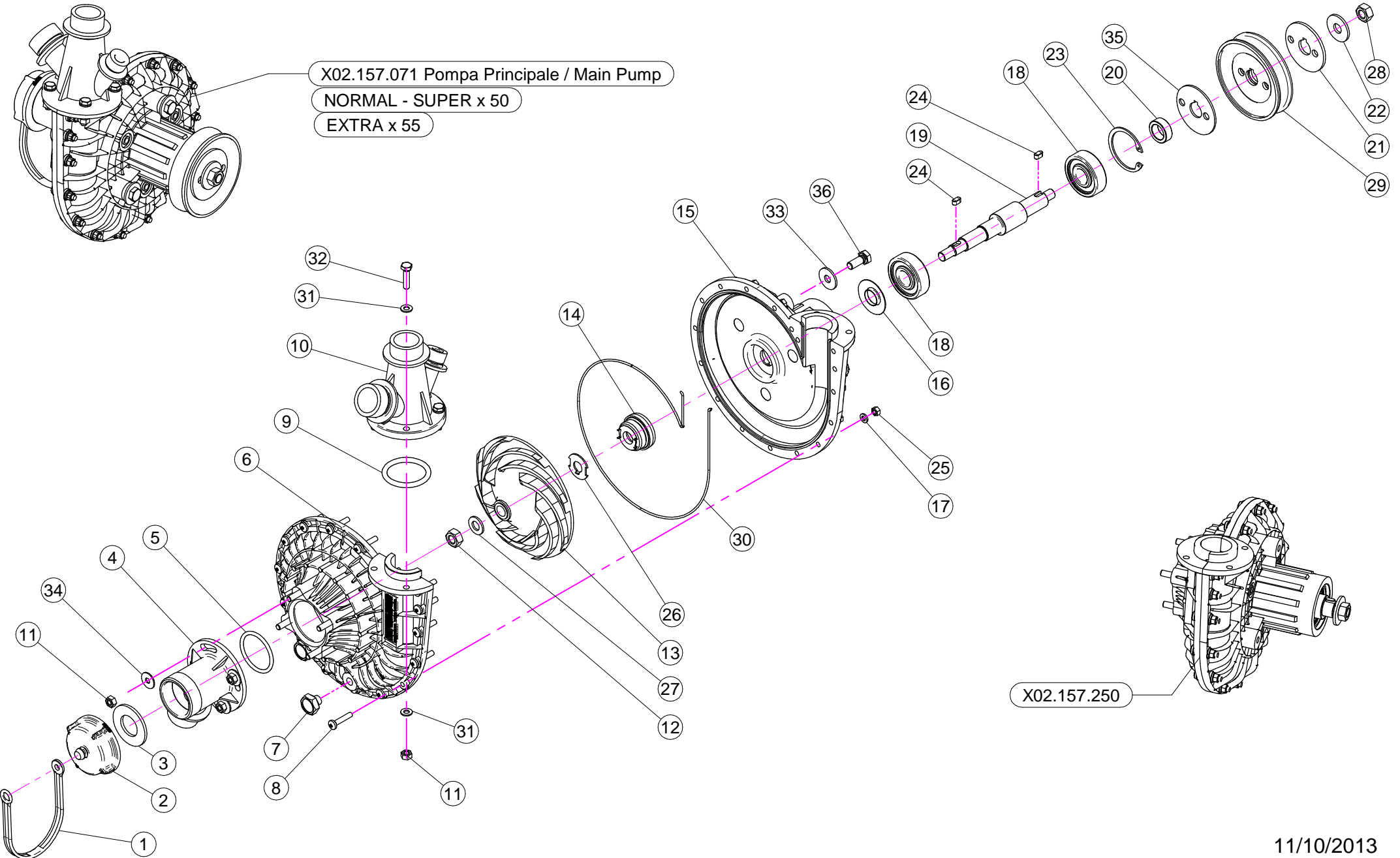

N°	Doc. Number	Titolo	Title	Qtà	Note
1	X21.183.000	STRISCIA FERMATAPPI	CAP STOP	1	
2	X02.120.000	TAPPO A FILETTO RAPIDO M47 x 5	RAPID THREAD CAP	1	
3	X02.130.000	GUARNIZIONE IN GOMMA DIAM. 24X46X3	24X46X3 RUBBER GASKET	1	
4	X02.116.000	RACCORDO DI ASPIRAZIONE	SUCTION FITTING	1	
5	XOR.000.144	OR D.39,69x3,53	O-RING D.39,69x3,53	1	
6	X02.152.010	COPERCHIO POMPA CD 32	HOUSING	1	
7	XTM.010.015	TAPPO M10X1,5	M10X1,5 CAP	2	
8	XTC.05.25.85	VITE TESTA A CROCE 48 M5X25	CROSS SLOTTED SCREW M5X25	17	
9	XOR.006.162	OR D.40,65 x 5,34	O-RING GASKET 40,65 x 5,34	1	
10	X02.113.001	RACCORDO DI MANDATA	DELIVERY FITTING	1	
11	XDOT.06.5587	DADO OTTONE M6	M6 BRASS NUT 5587	8	
12	XDOT.10.5587	DADO OTTONE M10	M10 BRASS NUT	1	
13	X02.153.000	GIRANTE POMPA CD 32	CD 32 PUMP IMPELLER	1	
14	X00.085.024CS	TENUTA MECCANICA	MECHANICAL SEAL	1	
15	X02.151.011	CORPO POMPA CD 32 LUNGO	PUMP CASING MODEL 2013	1	
16	X20.406.000	COPERCHIETTO SPECIALE POMPA CD 32	SPECIAL COVER FOR PUMP	1	
17	XRP.005.000	RONDELLA PIANA D.5	WASHER D.5	17	
18	XK6.303.2RS	CUSCINETTO A SFERE	ROLLER BEARING	2	
19	X02.155.010	ALBERO POMPA CD 32 INOX LUNGO	CD32 PUMP SHAFT	1	
20	X02.722.000	DISTANZIALE POMPA	BUSH	1	
21	X02.723.001	RONDELLA SPECIALE mm3	SPECIAL WASHER mm3	1	
22	XRP.010.030	RONDELLA PIANA D.10 x 30 mm	WASHER D.10 x 30 mm	1	
23	XI0.047.000	ANELLO ELASTICO INTERNO D.47	INTERNAL D.47 CIRCLIP	1	
24	XL.05.05.10	LINGUETTA 5X5X10	5X5X10 TANG	2	
25	XDOT.05.5587	DADO OTTONE M5 (5587)	M5 BRASS NUT (5587)	17	
26	X02.114.000	RONDELLA SPECIALE INOX	INOX SPECIAL WASHER	1	
27	XRP.010.001	RONDELLA PIANA D.10 INOX	WASHER D.10 INOX	1	
28	XD0.10.5588G	DADO M 10 6S PG	M10 6S BIG LEAD NUT 5588	1	
29	X02.723.002	PULEGGIA COMANDO POMPA D.82,5 X 1 3V	PULLEY FOR PUMP D.82,5 X 1 3V	1	
30	XOR.C02.070	CORDA OR D.2 L=700	OR CORD D.2 L=700	1	
31	XRP.006.000	RONDELLA PIANA D. 6	WASHER D.6	8	
32	XTE.006.025T	VITE TE M6X25	SCREW TE M6X25	4	
33	XRP.008.024	RONDELLA PIANA LARGA D.8X24	WASHER D.8X24	3	
34	XRP.006.018	RONDELLA PIANA D. 6x18	WASHER D.6x18	4	
35	X02.723.005	RONDELLA SPECIALE mm2	SPECIAL WASHER mm2	1	
36	XTE.008.020T	VITE TE 8x20	SCREW TE 8x20	3	

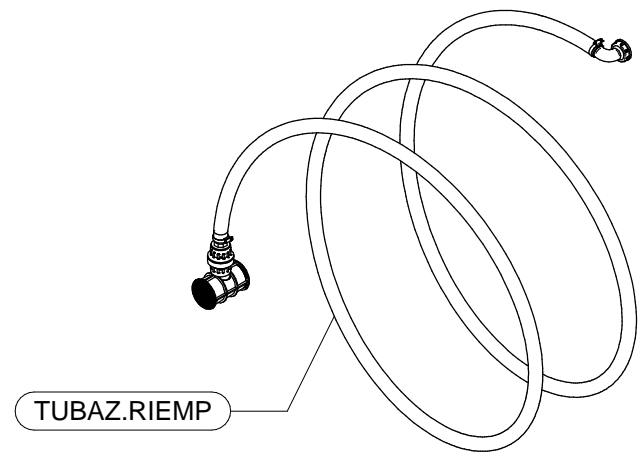
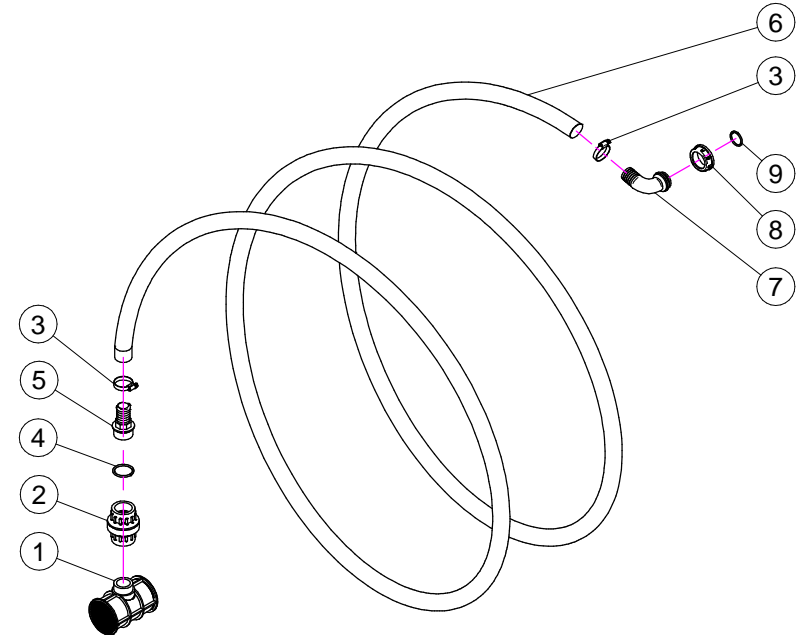
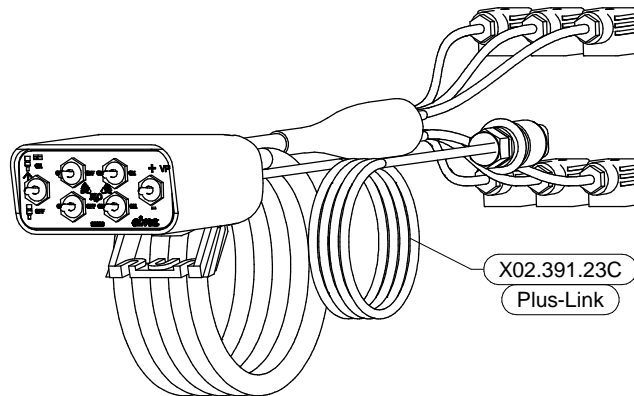
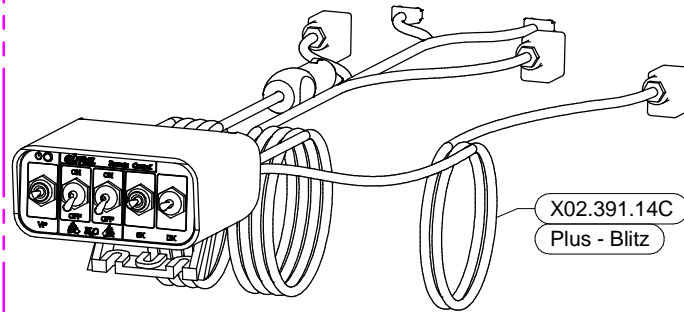
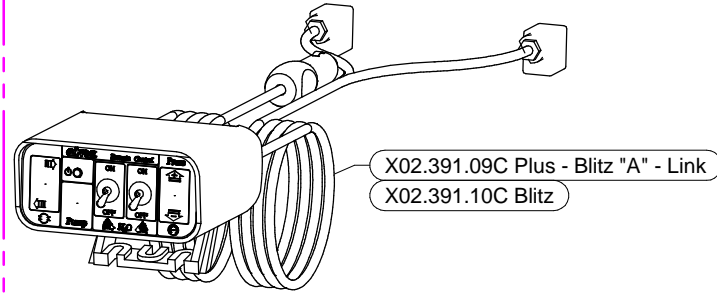
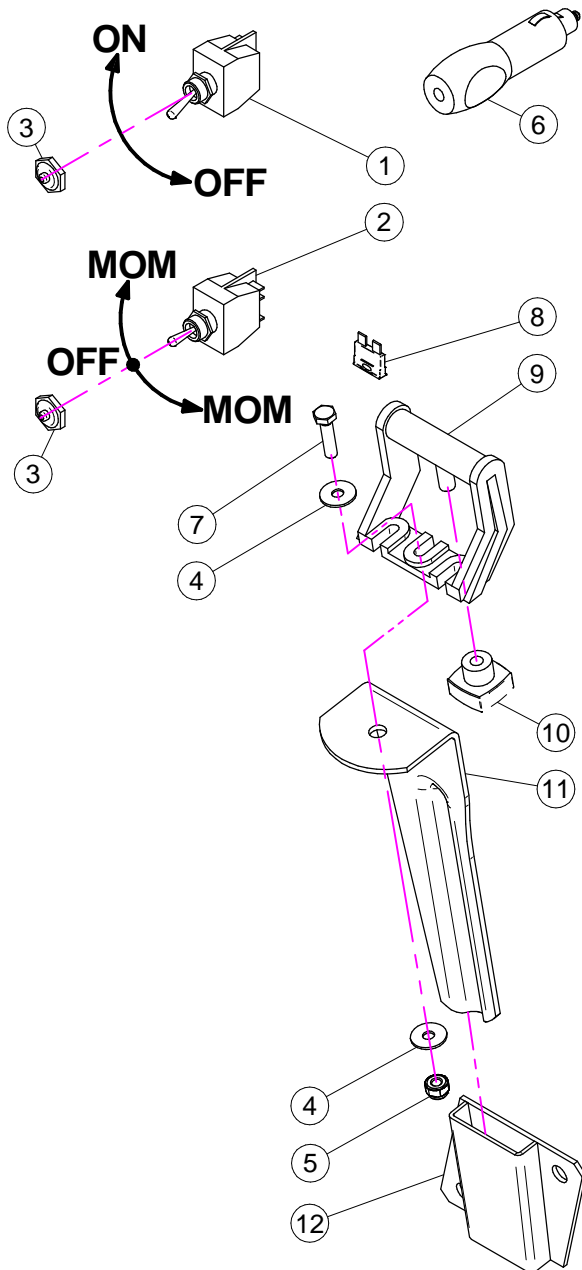

X02.391.09C / 10C / 14C / 23C

N°	Doc. Number	Titolo	Title	Q.tà	Note
1	X21.030.005	DEVIATORE 2V 2P ON-OFF 10A	SWITCH 2V 2P ON-OFF 10A	1	
2	X21.030.006	DEVIATORE MOM - 0 - MOM 10A	SWITCH MOM - 0 - MOM 10A	1	
3	X21.030.007	CAPPUCCIO INTERRUTTORE D.12	SWITCH CAP D.12	2	
4	XRP.006.018	RONDELLA PIANA D. 6x18	WASHER D.6x18	2	
5	XDA.006.0AG	DADO AUTOBLOCCANTE M6 ALTO PG	SELF-LOCKING NUT - HIGH M6	1	
6	X21.030.008	CONNETTORE DI ALIMENTAZIONE 12V	12V POWER JACK	1	
7	XTE.006.025T	VITE TE M6X25	SCREW TE M6X25	1	
8	X21.030.004	FUSIBILE - 10 Ah	10 Ah FUSE	1	
9	X21.030.002	STAFFA DI FISSAGGIO MOBILE	MOVING FIXING BRACKET	1	
10	X21.030.003	POMELLO DI BLOCCAGGIO	FIXING KNOB	1	
11	X20.111.000	STAFFA PORTA BAIONETTA	BRACKET	1	
12	X20.107.000	SUPPORTO A BAIONETTA FEMMINA	FEMALE BAYONET SUPPORT	1	

TUBAZ.RIEMP

N°	Doc. Number	Titolo	Title	Q.tà	Note
1	X00.611.000	FILTRO A T PER TUBAZIONE RIEMPIMENTO	T FILTER	1	
2	X00.300.000	VALVOLA DI FONDO F-F 1" 1/4	FOOT VALVE F-F 1" 1/4	1	
3	XF0.025.040I	FASCETTA A VITE 25/40 W4 INOX	STAINLESS STEEL CLIP	2	
4	XOR.000.144	OR D.39,69x3,53	O-RING D.39,69x3,53	1	
5	X00.423.000	RACCORDO DIRITTO PG 30 FIL.1" 1/4 GAS	MALE CONNECTOR RH 30 1" 1/4 GAS	1	
6	X02.238.450	TUBO SPIRALATO D.30 L=4500	SPIRAL HOSE D.30 L=4500	1	
7	X00.481.000	RACCORDO CURVO P.G. D.30	D.30 HOSETAIL	1	
8	X02.165.000	GIRELLO A FILETTO RAPIDO	RAPID THREAD FLY NUT	1	
9	XOR.000.508	OR D.30 x 3	30 x 3 O-RING GASKET	1	

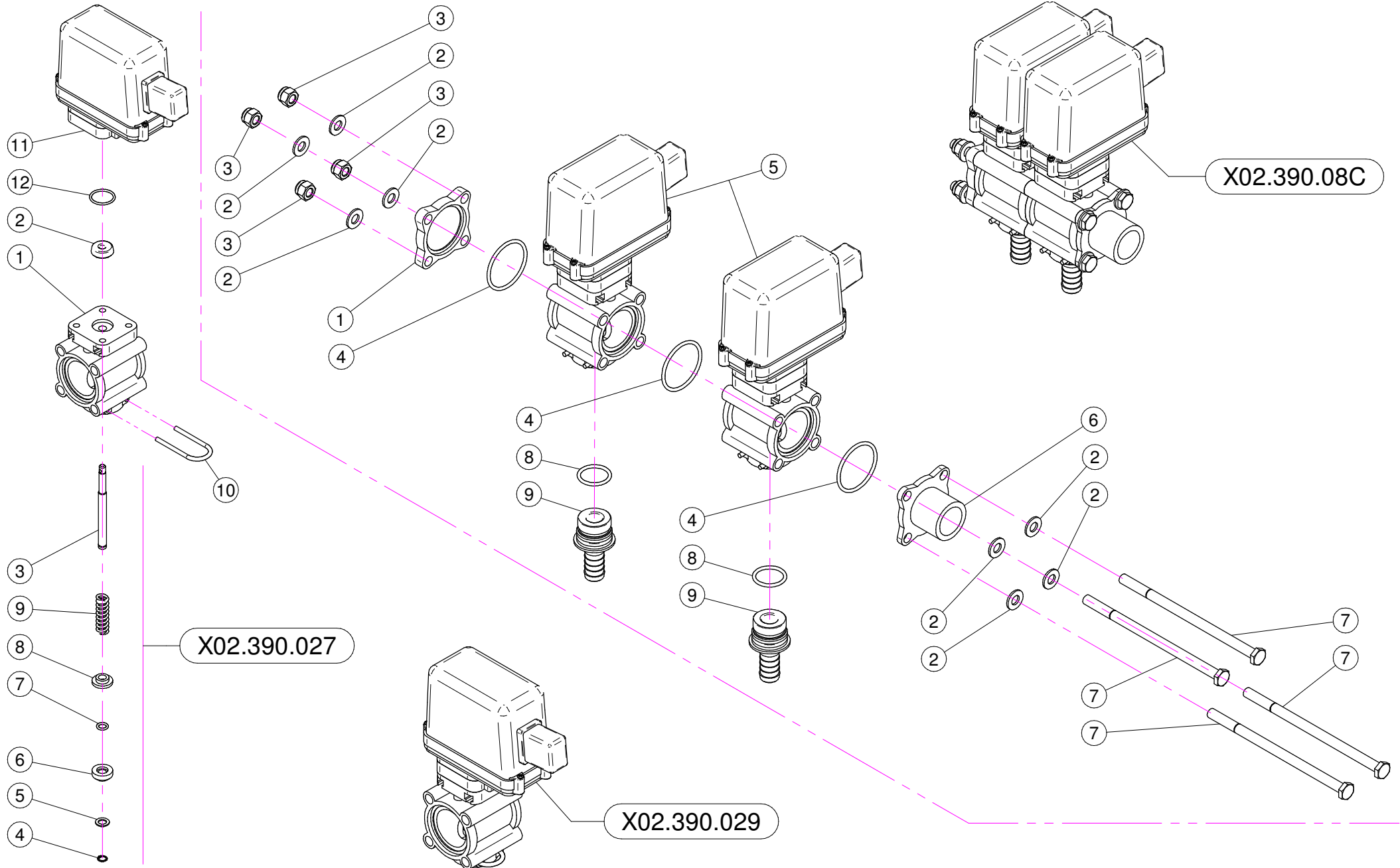

X02.390.029

N°	Doc. Number	Titolo	Title	Q.tà	Note
1	X02.390.007	CORPO VALVOLA	VALVE BODY	1	
2	X02.390.008	GUARNIZIONE D.6x17x6 VITON	GASKET	1	
3	X02.390.020	PERNO VALVOLA MANUALE INOX	PIN	1	
4	X02.390.013	ANELLO ARRESTO	STOP RING	1	
5	X02.390.014	RONDELLA PIANA 7,2 x 12 INOX	WASHER 7,2 x 12 INOX	1	
6	X02.390.015	PIATTELLO INFERIORE VALVOLA	LOWER PIATTELLO VALVE	1	
7	X02.390.016	OR 6,7 x 1,78	O RING	1	
8	X02.390.009	PIATTELLO SUPERIORE VALVOLE	SUPERIOR PIATTELLO VALVES	1	
9	X02.390.011	MOLLA DI RITEGNO	SPRING	1	
10	X21.130.005	FORCHETTA PER RUB. MAN. SEMP. PR	FORK	1	
11	X02.390.028	ELETTRIVALVOLA COMPLETA ARAG BLU	SOLENOID VALVE	1	
12	XOR.002.075	OR D.18.77 X 1.78	D.18.77 X 1.78 O-RING	1	

X02.390.08C

N°	Doc. Number	Titolo	Title	Q.tà	Note
1	X02.390.017	FLANGIA VALVOLE	VALVE FLANGE	1	
2	XRP.008.000	RONDELLA PIANA D.8	WASHER D.8	8	
3	XDA.008.0AG	DADO AUTOBLOCCANTE M8	SELF LOCKING NUT M8	4	
4	XOR.003.156	OR D.39,34x2,62	O-RING GASKET 39,34x2,62	3	
5	X02.390.029	ELETTRIVALVOLA COMPLETA ARAG BLU	SOLENOID VALVE	2	
6	X02.390.018	RACCORDO FLANGIATO 1" GAS	CONNECTOR	1	
7	XTE.008.150	VITE TE M8x150	SCREW TE M8 x 150	4	
8	XOR.000.130	OR D.22,22 x 2,62	22,22 x 2,62 O-RING GASKET	2	
9	X02.406.000	PORTAGOMMA D.16 ATT.RAP. PER ELETT.	HOSETAIL D.16	2	

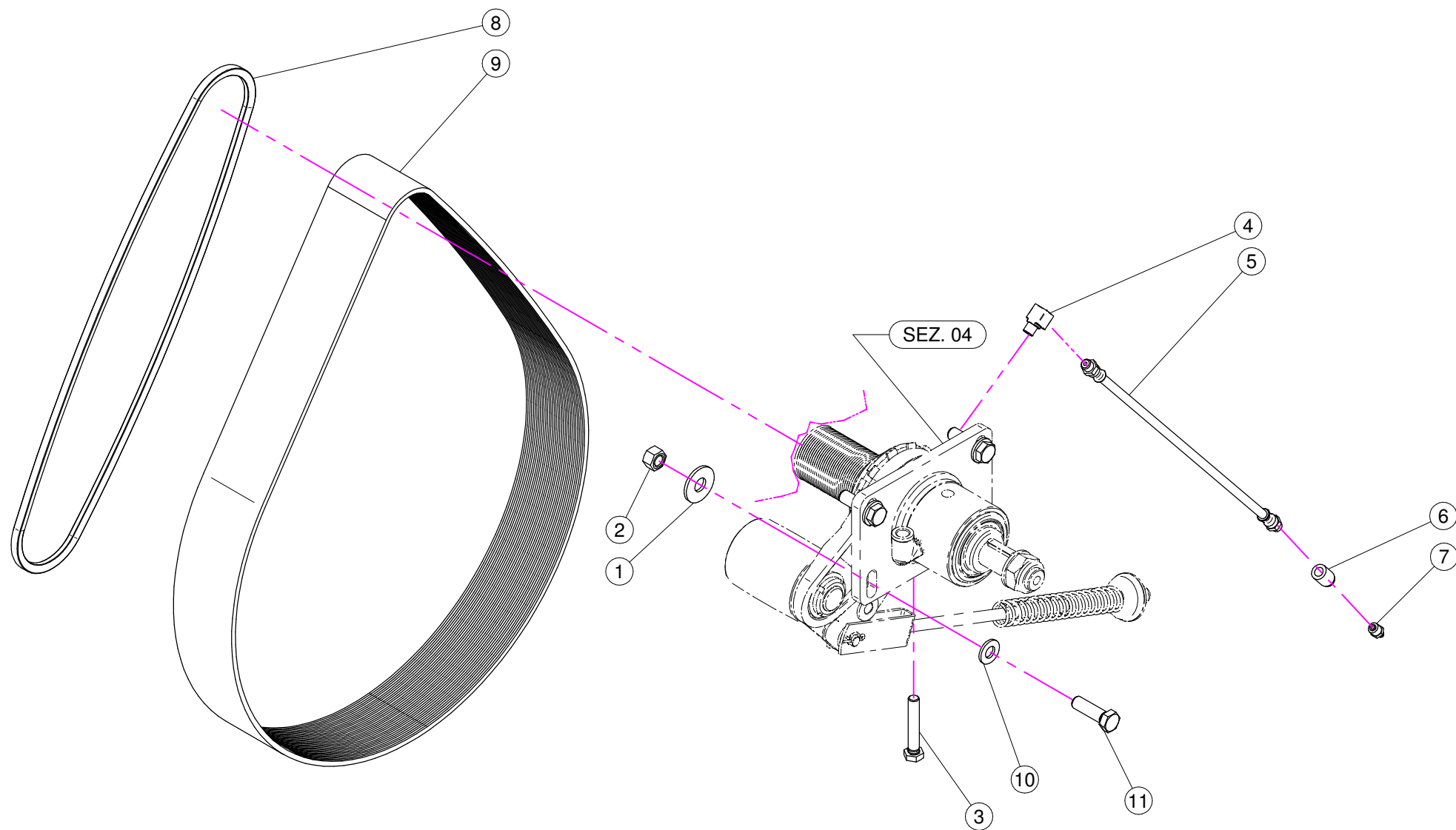

N°	Doc. Number	Titolo	Title	Q.tà	Note
1	XRP.012.036	RONDELLA PIANA D12 X 36	WASHER D12 X 36	4	
2	XD0.12.5587G	DADO M12 PG UNI 5587	M12 NUT	4	
3	XTE.010.060T	VITE TE M10 x 60	SCREW TE M10 x 60	1	
4	X02.736.000	RACCORDO INGRASSAGGIO 90 G. M10 X1	90 G. M10 X1 FITTING	1	
5	X02.738.040	PROLUNGA FLESSIBILE M10 x 1 L= 400	GREASER EXTENSION M10 x 1 L= 400	1	
6	X02.737.000	BOCCOLA PER INGRASSATORE	ACCESSORI	1	
7	XID.010.001	INGRASSATORE DIRITTO M10X1	GREASE NIPPLE	1	
8	XC0.500.03V	CINGHIA TRAPEZOIDALE	V - BELT	1	
9	XC0.650.J32	CINGHIA POLY-V	POLY-V BELT	1	
10	XRP.012.000	RONDELLA PIANA D. 12	WASHER D. 12	4	
11	XTE.012.040T	VITE TE M12X40 UNI 5739	BOLT TE M12X40	4	

DI SERIE / STANDARD

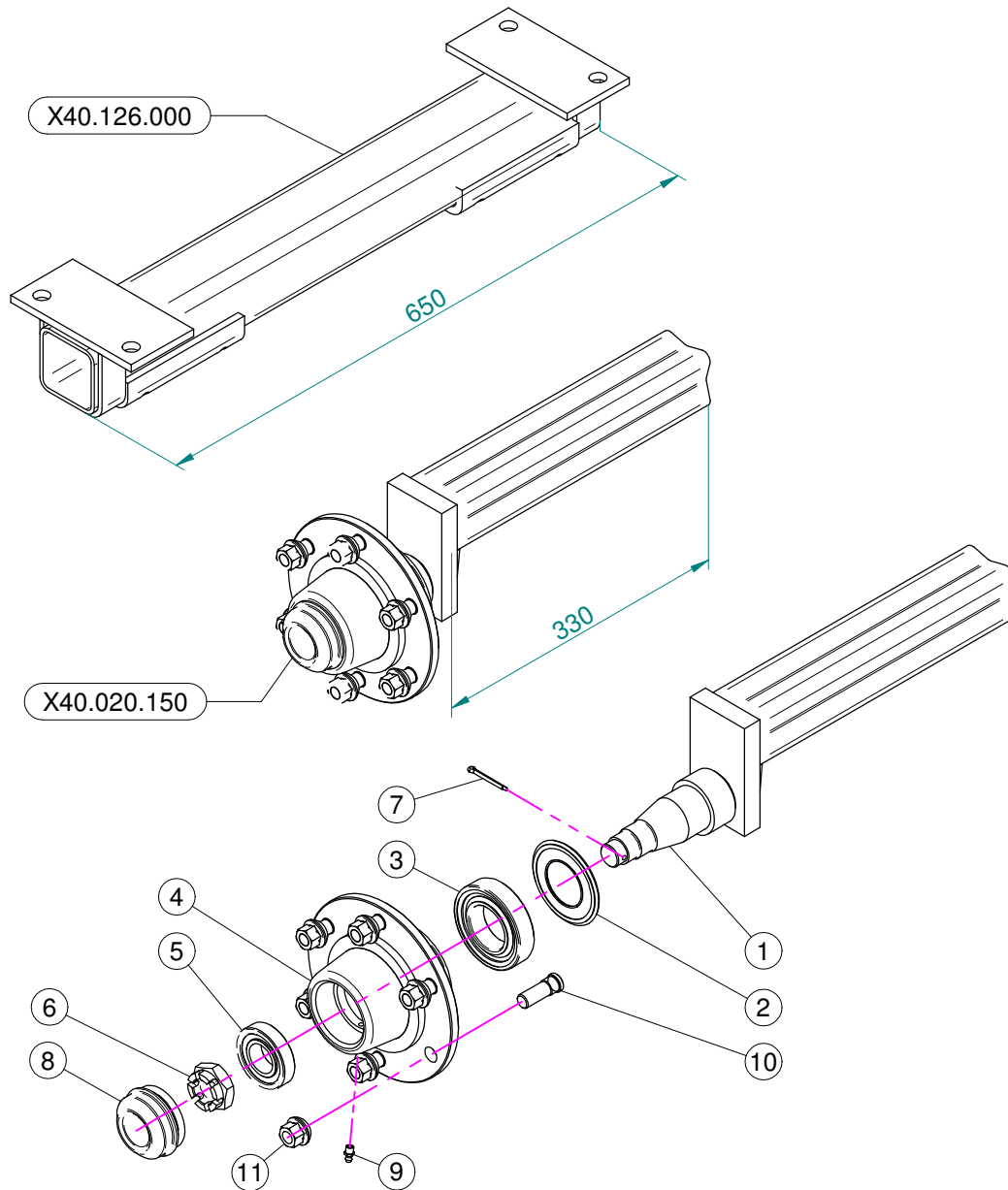

A RICHIESTA / OPTIONAL

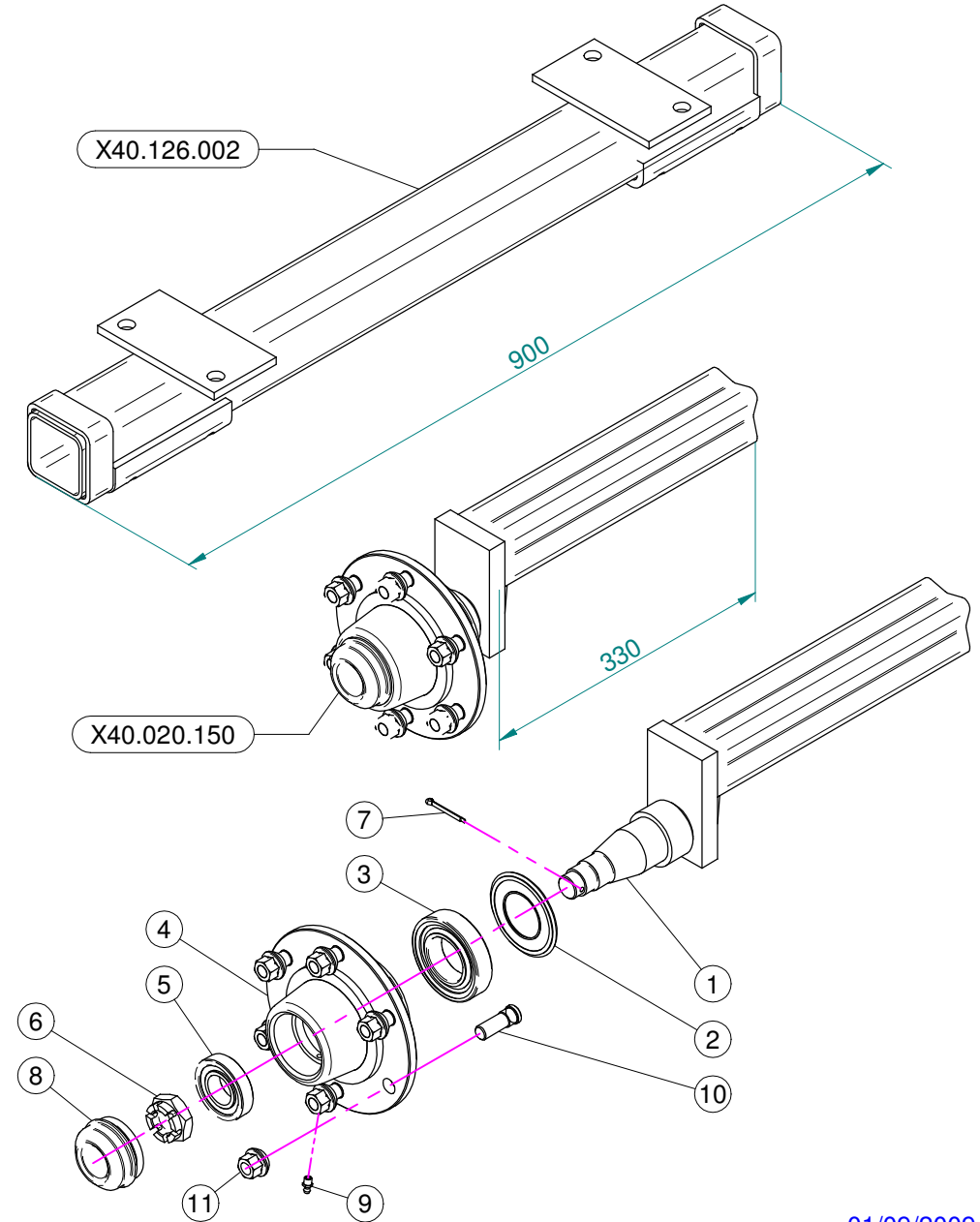

N°	Doc. Number	Titolo	Title	Q.tà	Note
1	X40.020.151	SEMIASSE A 6 COLONNETTE NON FORNITO	AXLE SHAFT NOT SUPPLYED	1	N.D.
2	X20.258.000	PARA-OLIO 45x85 IN GOMMA	OIL COVER	1	
3	XK0.030.209	CUSCINETTO A UNA CORONA DI RULLI CONICI	BEARING	1	
4	X05.903.001	MOZZI A 6 FORI GEARMORE	SIX HOLES FLANGE	1	N.D.
5	XK0.030.206	CUSCINETTO A UNA CORONA DI RULLI CONICI	BEARING	1	
6	XDI.027.5594F	DADO ESAGONALE A 6 INTAGLI	SIX CASTLE NUT M27	1	
7	X20.259.000	COPIGLIA D.4 L=45 PER MOZZI	SPLIT PIN	1	
8	X04.062.001	COPERCHIETTO DI CHIUSURA	COVER	1	
9	XID.006.001	INGRASSATORE DIRITTO M6	GREASER	1	
10	X05.911.001	COLONNETTA PER SEMIASSE M14x1.5	STUD	6	
11	X05.911.000	DADO PER COLONNETTA M14x1.5	SPECIAL NUT	6	

Gli esplosi elencati di seguito, sono relativi
a varianti od accessori a richiesta

Exploded drawings here listed, concern
variations or demanded accessories

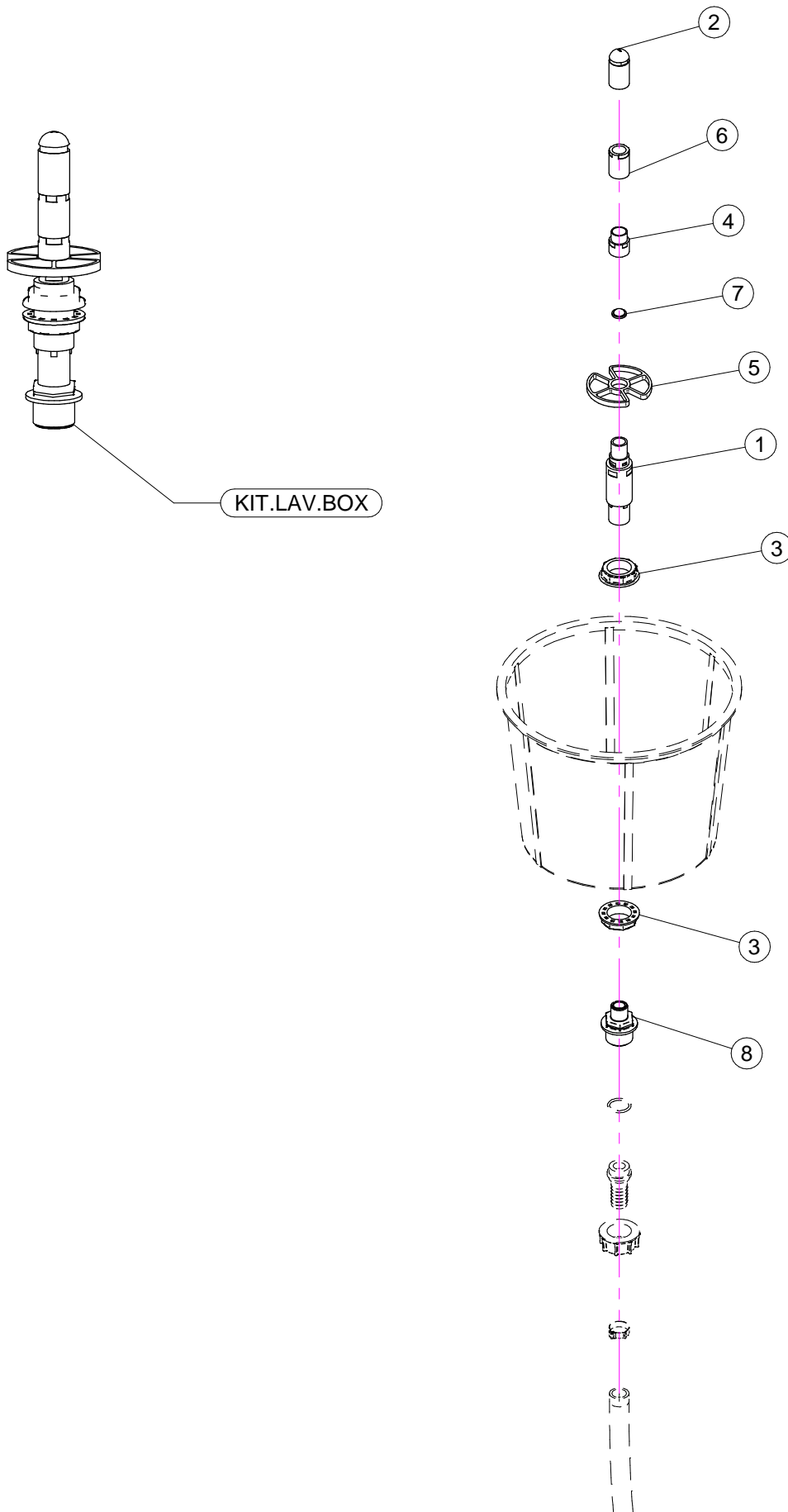

N°	Doc. Number	Titolo	Title	Q.tà	Note
1	X21.190.000	VALVOLA PER TESTINA LAVAGGIO CONTENITORI	VALVE FOR BOX WASH HEAD	1	
2	X21.191.000	TESTINA PER LAVAGGIO CONTENITORI	HEAD FOR BOX WASH	1	
3	X00.542.000	GHIERA 1"	NUT 1"	2	
4	X21.414.000	PORTAFILTRO	FILTER RING	1	
5	X21.411.000	FERMO BARATTOLO	BOX BLOCK	1	
6	X21.412.000	PORTA TESTINA PER LAVAGGIO CONTENITORI	HEAD BASE FOR BOX WASH	1	
7	X21.413.000	FILTRO PER LAVABARATTOLO	FILTER	1	
8	X21.410.000	NIPPLO 1/2M - 1M	NIPPLE 1/2M - 1M	1	

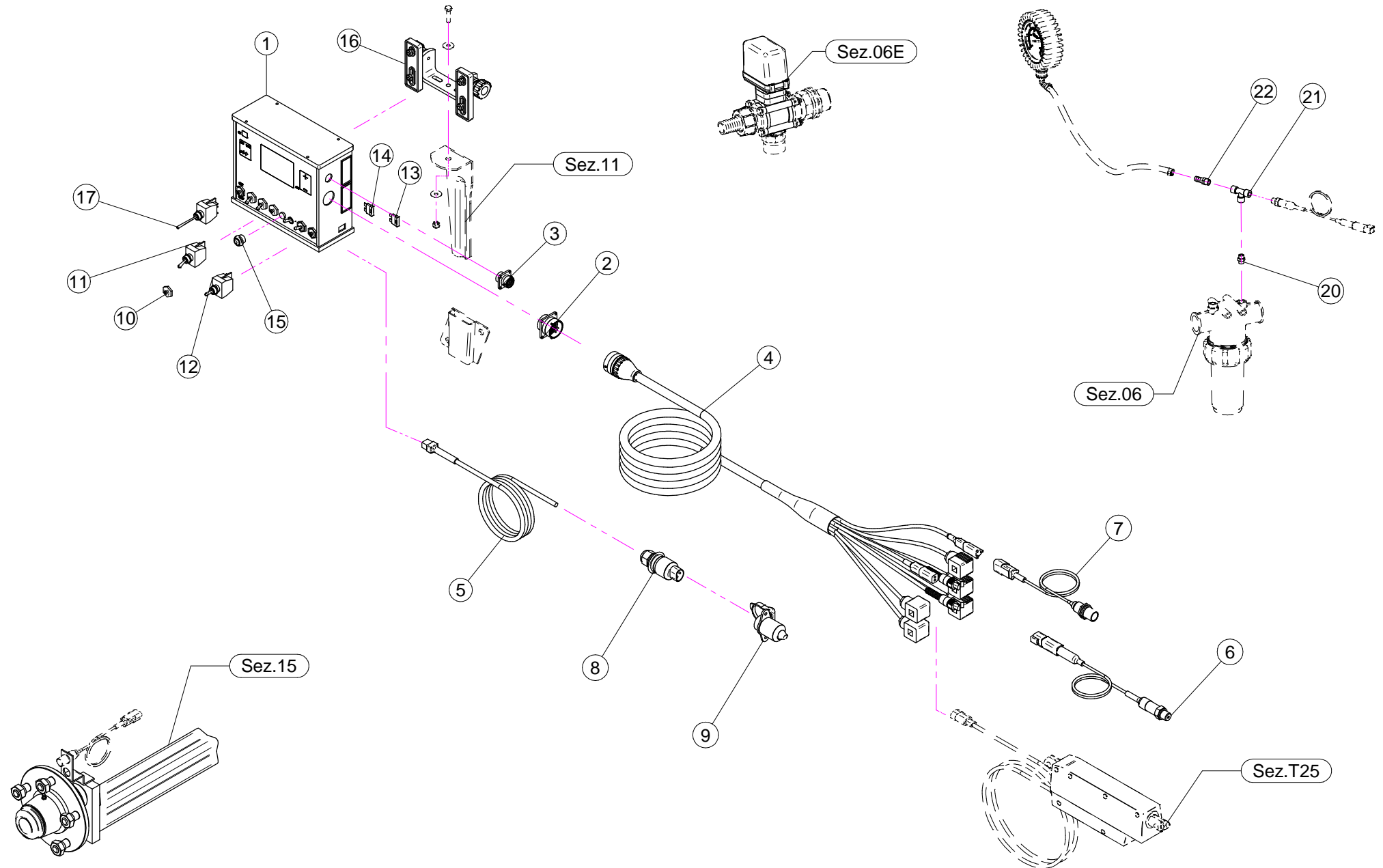

N°	Doc. Number	Titolo	Title	Q.tà	Note
1	X21.138.200	COMPUTER SERIE 844 AB	COMPUTER SERIES 844 AB	1	
2	X21.166.000	CONNETTORE BURNDY 28 PIN	BURNDY 28 PIN CONNECTOR	1	
3	X21.167.000	CONNETTORE BURNDY 8 PIN	BURNDY 8 PIN CONNECTOR	1	
4	X21.143.100	CAVO DATI COMPUTER 4VP+2AT-SP	COMPUTER DATA CABLE 4VP+2AT-SP	1	
5	X21.161.000	CAVO DI ALIMENTAZIONE COMPUTER	COMPUTER POWER WIRE	1	
6	X21.140.000	TRASDUTTORE DI PRESSIONE 0-10 BAR	PRESSURE TRANSDUCER	1	
7	X21.139.000	SENSORE DI VELOCITA' CL5X	SPEED SENSOR	1	
8	X21.162.000	SPINA DI ALIMENTAZIONE CAVO TRIPOLARE	POWER PLUG	1	
9	X21.163.000	PRESA DI ALIMENTAZIONE TRIPOLARE	POWER PLUG	1	
10	X21.030.007	CAPPUCCIO INTERRUTTORE D.12	SWITCH CAP D.12	7	
11	X21.030.005	DEVIATORE 2V 2P ON-OFF 10A	SWITCH 2V 2P ON-OFF 10A	5	
12	X21.030.006	DEVIATORE MOM - 0 - MOM 10A	SWITCH MOM - 0 - MOM 10A	1	
13	X21.030.004	FUSIBILE - 10 Ah	10 Ah FUSE	1	
14	X21.168.000	FUSIBILE - 5 Ah	5 Ah FUSE	1	
15	X21.170.000	INTERRUTTORE PULSANTE 2V 2P ON - OFF	PUSH-BUTTON SWITCH 2V 2P ON - OFF	1	
16	X21.165.000	STAFFA DI FISSAGGIO	BRACKET	1	
17	X21.030.018	DEVIATORE LUNGO 2V 2P ON-OFF 10A	LONG SWITCH 2V 2P ON-OFF 10A	1	

N°	Doc. Number	Titolo	Title	Q.tà	Note
20	X24.004.000	NIPPLO M/M 1/4"	NIPLES M/M 1/4"	1	
21	X21.172.000	RACCORDO A T 1/4" F/F/F	T FITTING 1/4" F/F/F	1	
22	X00.414.000	PORTAGOMMA D.11 1/4" M. FORATO	STRAIGHT HOSE D.11 1/4"	1	

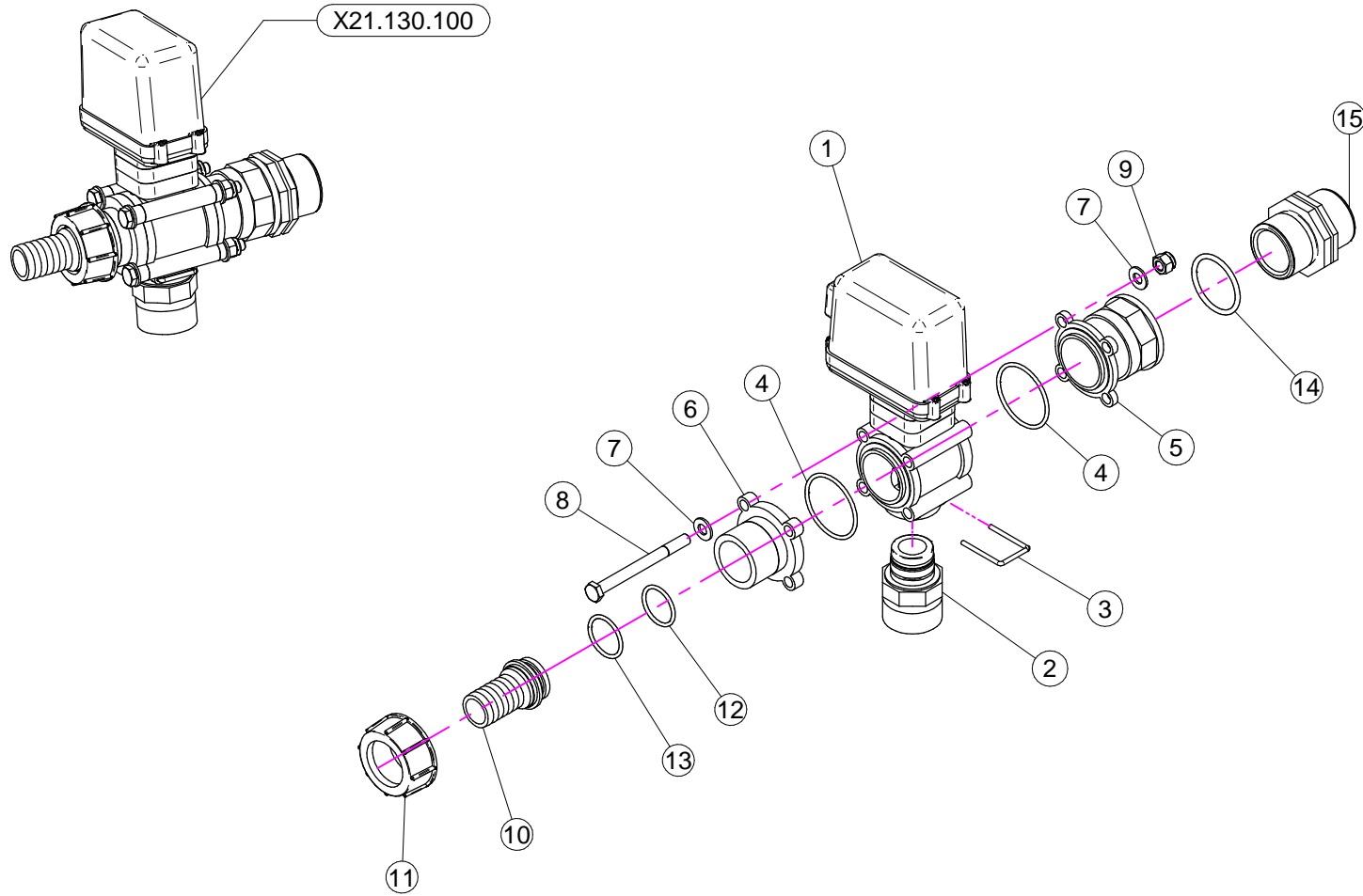

N°	Doc. Number	Titolo	Title	Q.tà	Note
1	X21.130.100	VALVOLA DI REGOLAZIONE PROPORZIONALE ELETTRICA VELOCE	QUICK ELECTRIC PROPORTIONAL VALVE	1	
2	X21.131.000	RIDUZIONE ATT.RAP. G 1" 1/4	REDUCTION J. F. G 1" 1/4	1	
3	X21.130.005	FORCHETTA ATTACCO RAPIDO	FORK FASTNER JOINT	1	
4	XOR.003.181	OR D. 45,69x50,93x2,62	45,69x50,93x2,62 O-RING	2	
5	X21.133.000	RACCORDO FLANGIATO 1" - 1 1/4"	CONNECTOR	1	
6	X21.132.000	FLANGIA VALVOLE	VALVE FLANGE	1	
7	XRP.008.000	RONDELLA PIANA D.8	WASHER D.8	8	
8	XTE.008.090	VITE TE M8 x 90	SCREW TE M8 x 90	4	
9	XDA.008.0AG	DADO AUTOBLOCCANTE M8	SELF LOCKING NUT M8	4	
10	X02.363.000	RACCORDO DIRITTO PG D.25 - 1 1/4	STRAIGHT HOSE R.H D.25 - 1 1/4	1	
11	X00.058.006	GIRELLO 1" 1/4 GAS	1" 1/4 FLY NUT	1	
12	XOR.003.106	OR D.26.65x2.62	O-RING D.26.65x2.62	1	
13	XOR.003.112	OR D.28,24x2,62	O-RING D.28,24x2,62	1	
14	XOR.000.144	OR D.39,69x3,53	O-RING D.39,69x3,53	1	
15	X00.345.010	NIPPLO 1" 1/4 + 1" 1/4 GAS	NIPPLE 1" 1/4 + 1" 1/4 GAS	1	

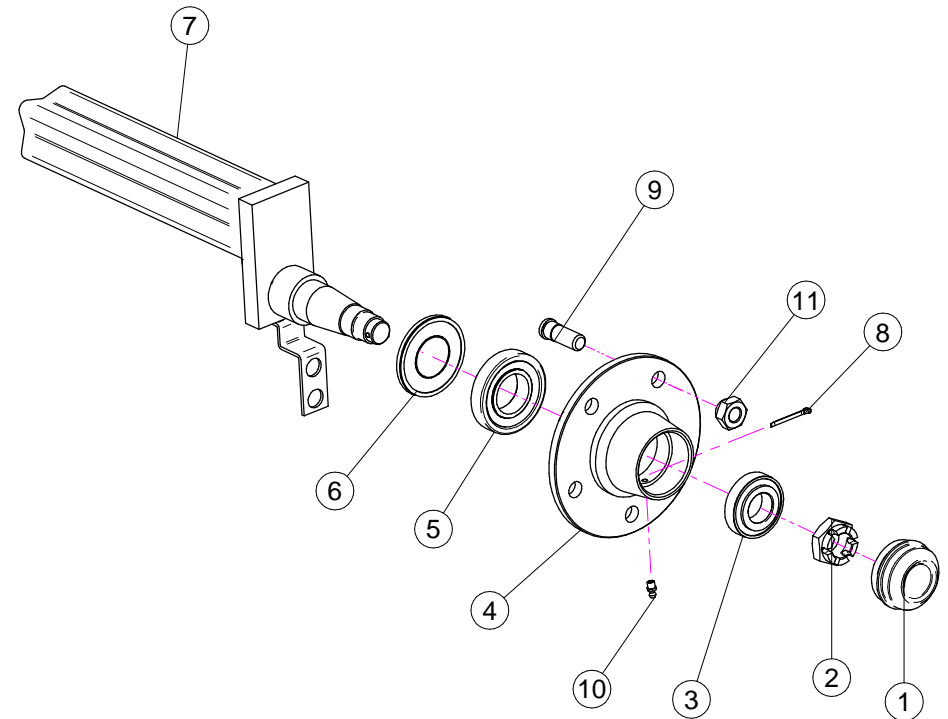
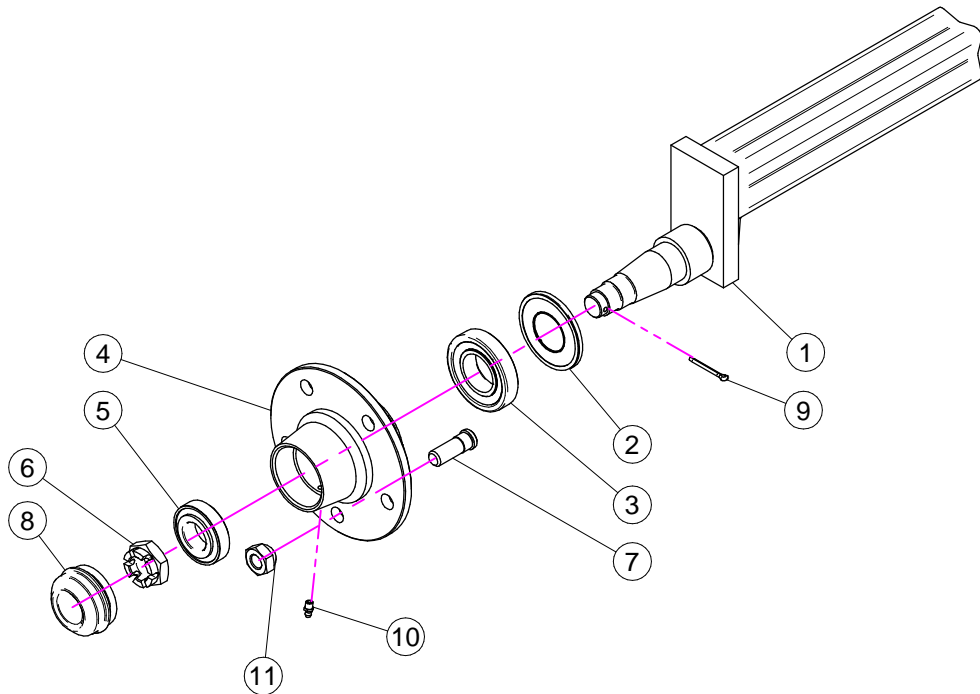
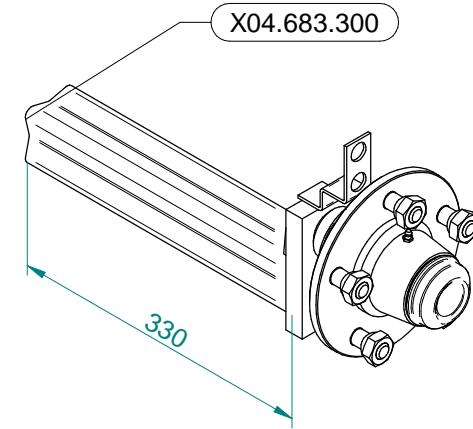
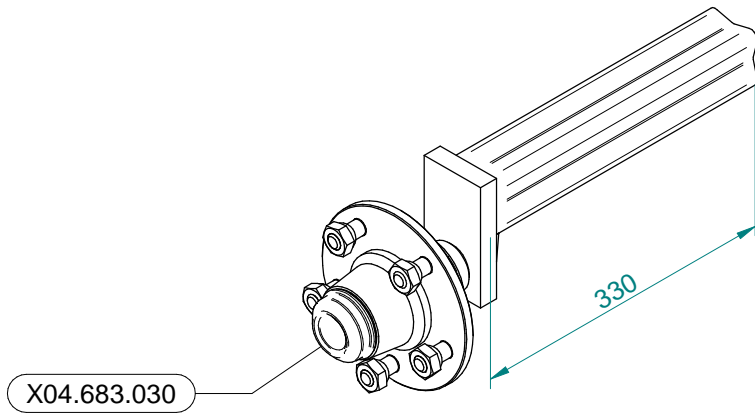

X04.683.030

N°	Doc. Number	Titolo	Title	Q.tà	Note
1	X04.683.006	SEMIASSE A 5 COLONNETTE	AXLE SHAFT	1	N.D.
2	X20.257.000	PARA - POLVERE D. 40x80 IN GOMMA	DUST SHIELDER	1	
3	XK0.030.208	CUSCINETTO A UNA CORONA DI RULLI CONICI	BEARING	1	
4	X04.683.003	FLANGIA MOZZI A 5 FORI	FIVE HOLES FLANGE	1	N.D.
5	XK0.030.206	CUSCINETTO A UNA CORONA DI RULLI CONICI 30206	BEARING	1	
6	XDI.027.5594F	DADO ESAGONALE A 6 INTAGLI	SIX CASTLE NUT M27	1	
7	X04.681.000	COLONNETTA PER SEMIASSE M16x1,5	STUD M16x1,5	5	
8	X04.062.001	COPERCHIETTO DI CHIUSURA	COVER	1	
9	X20.259.000	COPIGLIA D.4 L=45 PER MOZZI	SPLIT PIN	1	
10	XID.006.001	INGRASSATORE DIRITTO M6	GREASER	1	
11	X04.682.000	DADO PER COLONNETTA M 16x1.5	SPECIAL NUT	5	

X04.683.830

N°	Doc. Number	Titolo	Title	Q.tà
1	X04.062.001	COPERCHIETTO DI CHIUSURA	COVER	1
2	XDI.027.5594F	DADO ESAGONALE A 6 INTAGLI	SIX CASTLE NUT M27	1
3	XK0.030.206	CUSCINETTO A UNA CORONA DI RULLI CONICI 30206	BEARING	1
4	X04.683.003	FLANGIA MOZZI A 5 FORI	FIVE HOLES FLANGE	1
5	XK0.030.208	CUSCINETTO A UNA CORONA DI RULLI CONICI	BEARING	1
6	X20.257.000	PARA - POLVERE D. 40x80 IN GOMMA	DUST SHIELDER	1
7	X04.683.006	SEMIASSE A 5 COLONNETTE	AXLE SHAFT	1
8	X20.259.000	COPIGLIA D.4 L=45 PER MOZZI	SPLIT PIN	1
9	X04.681.000	COLONNETTA PER SEMIASSE M16x1,5	STUD M16x1,5	5
10	XID.006.001	INGRASSATORE DIRITTO M6	GREASER	1
11	X04.682.000	DADO PER COLONNETTA M 16x1.5	SPECIAL NUT	5

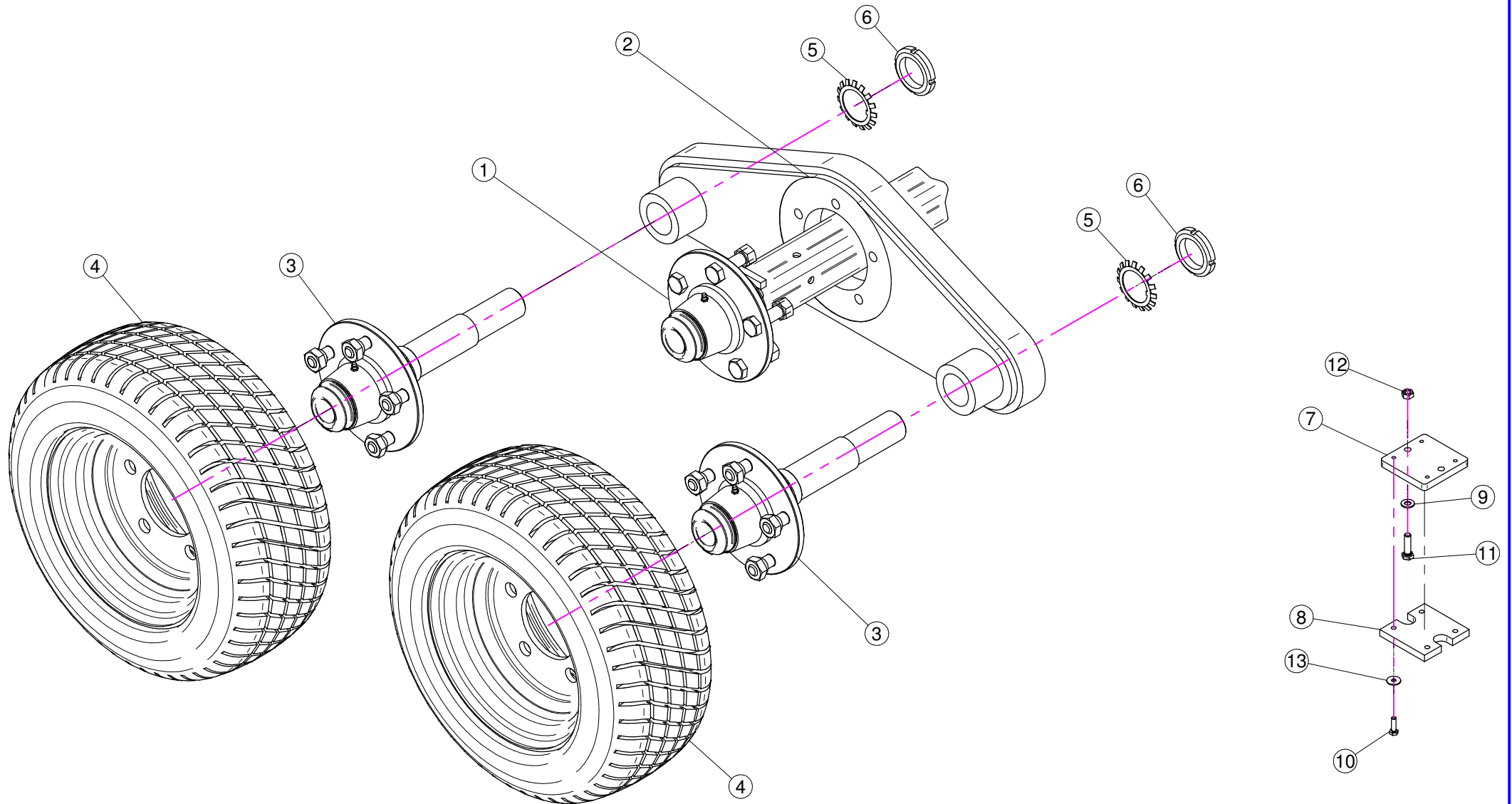

N°	Doc. Number	Titolo	Title	Q.tà	Note
1	X04.683.230	MOZZO A 5 COLONNETTE	WHEEL HUB	2	
2	X40.369.000	PIASTRA PORTA MOZZI RUOTE TANDEM	HUB SUPPORT SHEET	2	
3	X04.683.330	MOZZO A 5 COLONNETTE	WHEEL HUB	4	
4	X40.375.000	RUOTA 195/50 - 10 - 5Fori	TIRES	4	
5	XMB.009.000	ROSETTA DI SICUREZZA D.45	TOOTH LOCK WASHER	4	
6	XKM.009.000	GHIERA KM9	NUT KM9	4	
7	X40.373.001	SPESSORE FERMO RUOTE IN TANDEM	SPACER	4	
8	X40.374.001	SPESSORE IN GOMMA FERMO RUOTE IN TANDEM	SPACER	4	
9	XRP.008.000	RONDELLA PIANA D.8	WASHER D.8	16	
10	XTE.006.020T	VITE TE M6 x 20	SCREW TE M6 x 20	16	
11	XTE.008.030T	VITE TE M8x30	SCREW TE M8x30	8	
12	XD0.08.5588G	DADO M8 6S PG	M8 6S BIG LEAD NUT 5588	8	
13	XRP.006.018	RONDELLA PIANA D. 6x18	WASHER D.6x18	16	

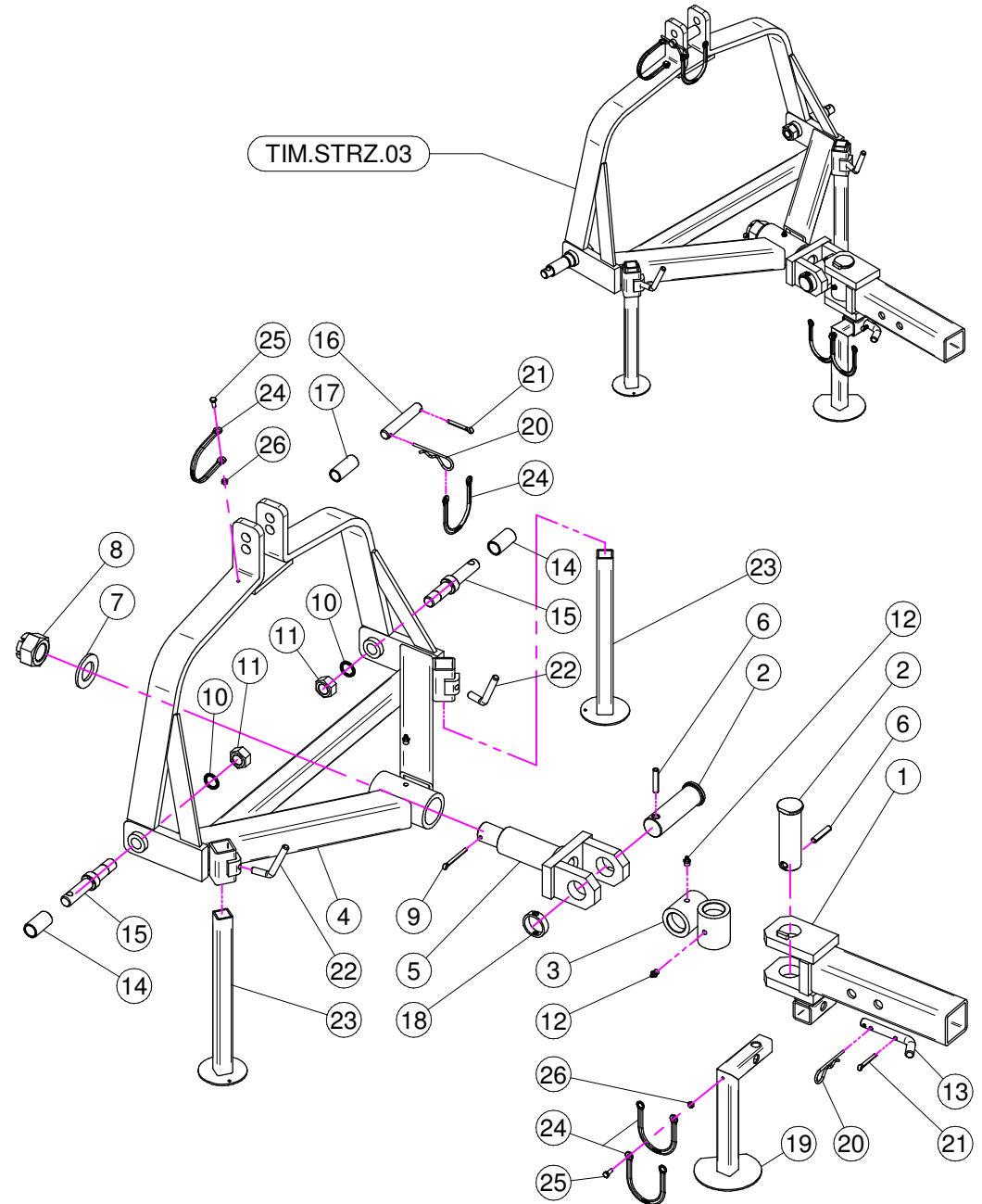
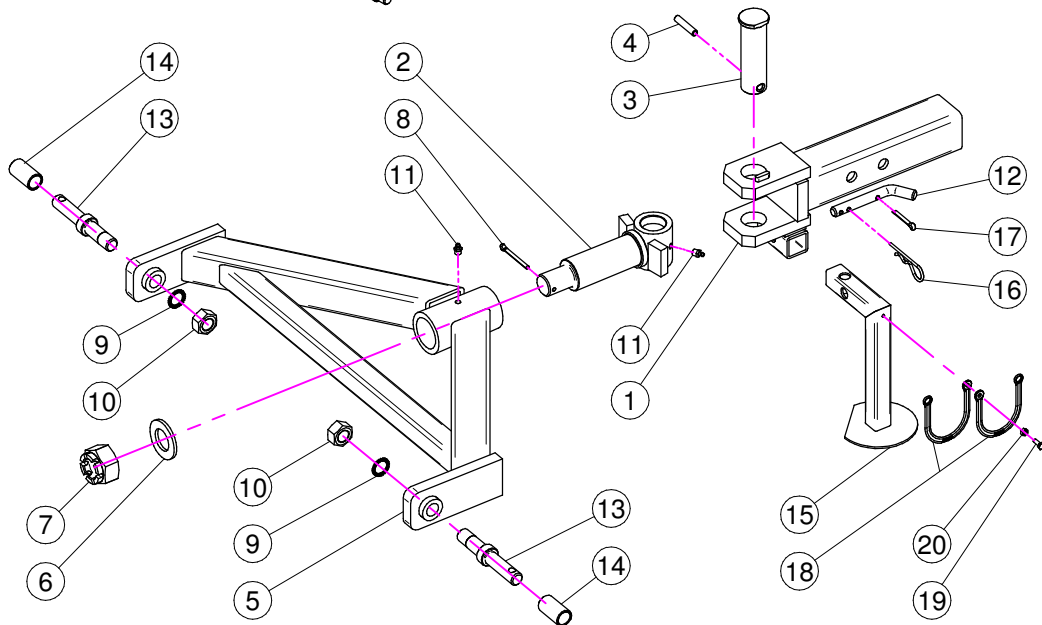
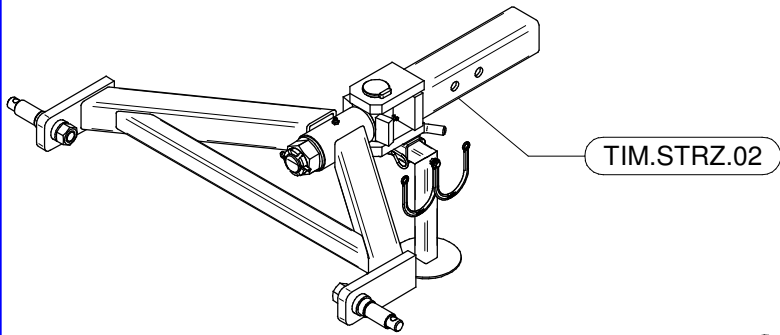
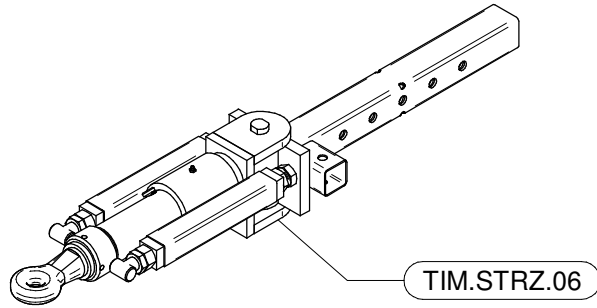

TIM.STRZ.02

N°	Doc. Number	Titolo	Title	Q.tà	Note
1	X40.153.001	TIMONE SNODATO - PARTICOLARE FISSO	DRAW-BAR - FIXING PARTICULAR	1	
2	X40.154.100	PERNO TIMONE STERZANTE A 2 PUNTI	PIN	1	
3	X40.150.000	PERNO PER TIMONE STERZANTE	PIN	1	
4	XSE.010.050	SPINA ELASTICA 10 x 50	SPRING PIN	1	
5	X40.152.000	CORPO A 2 PUNTI PER TIMONE STERZANTE	2 POINTS BODY	1	
6	XRP.036.000	RONDELLA PIANA Ø36	WASHER	1	
7	XDI.036.5593F	DADO AD INTAGLI M36	CASTLE NUT M30	1	
8	XCP.006.070	COPIGLIA	SPLIT PIN	1	
9	XRD.022.000	RONDELLA DENTELLATA D.22	TAB WASHER D.22	2	
10	XD0.22.5588F	DADO M22 x 1.5	NUT M22 x 1.5	2	
11	XID.010.001	INGRASSATORE DIRITTO M10X1	GREASE NIPPLE	2	
12	X20.505.000	SPINOTTO PIEDE D' APPOGGIO	PIN JACK STAND	1	
13	X04.064.100	SPINOTTO SOLLEVATORE	PIN POWER LIFT	2	
14	X40.202.000	BOCCOLA PER SPINOTTI SOLLEVATORE	BUSH	2	
15	X40.342.000	PIEDE D'APPOGGIO ESTRAIBILE	EXTRACTABLE JACK STAND	1	
16	X00.100.004	COPIGLIA D.4	SPLIT PIN D.4	1	
17	XCP.006.040I	COPIGLIA D.6 Lg.40	PIN D.6 Lg.40	1	
18	X21.183.000	STRISCIA FERMATAPPI	CAP STOP	2	
19	XTE.006.016T	VITE TE M6X16	SCREW TE M6X16	1	
20	XD0.06.5588G	DADO M6	NUT M6	1	

TIM.STRZ.03

N°	Doc. Number	Titolo	Title	Q.tà	Note
1	X40.153.001	TIMONE SNODATO - PARTICOLARE FISSO	DRAW-BAR - FIXING PARTICULAR	1	
2	X40.150.000	PERNO PER TIMONE STERZANTE	PIN	2	
3	X40.155.000	CROCERA PER TIMONE STERZANTE	JOINT	1	
4	X40.151.000	CORPO A 3 PUNTI PER TIMONE STERZANTE	3 POINTS BODY	1	
5	X40.154.000	PERNO PER TIMONE STERZANTE 3 PUNTI	PIN	1	
6	XSE.010.050	SPINA ELASTICA 10 x 50	SPRING PIN	2	
7	XRP.036.000	RONDELLA PIANA Ø36	WASHER	1	
8	XDI.036.5593F	DADO AD INTAGLI M36	CASTLE NUT M30	1	
9	XCP.006.070	COPIGLIA	SPLIT PIN	1	
10	XRD.022.000	RONDELLA DENTELLATA D.22	TAB WASHER D.22	2	
11	XD0.22.5588F	DADO M22 x 1.5	NUT M22 x 1.5	2	
12	XID.010.001	INGRASSATORE DIRITTO M10X1	GREASE NIPPLE	3	
13	X20.505.000	SPINOTTO PIEDE D' APPOGGIO	PIN JACK STAND	1	
14	X40.202.000	BOCCOLA PER SPINOTTI SOLLEVATORE	BUSH	2	
15	X04.064.100	SPINOTTO SOLLEVATORE	PIN POWER LIFT	2	
16	X04.076.000	SPINOTTO 3° PUNTO	PIN	1	
17	X20.778.000	BOCCOLA PER TERZO PUNTO PER PLUS	BUSH	1	
18	X40.363.000	DISTANZIALE	SPACER	1	
19	X40.342.000	PIEDE D'APPOGGIO ESTRAIBILE	EXTRACTABLE JACK STAND	1	
20	X00.100.004	COPIGLIA D.4	SPLIT PIN D.4	2	
21	XCP.006.040I	COPIGLIA D.6 Lg.40	PIN D.6 Lg.40	2	
22	X02.175.000	MANIGLIA DI BLOCCAGGIO	LOOKING HANDLE	2	
23	X40.251.200	PIEDE D'APPOGGIO	JACK	2	
24	X21.183.000	STRISCIA FERMATAPPI	CAP STOP	4	
25	XTE.006.016T	VITE TE M6X16	SCREW TE M6X16	2	
26	XD0.06.5588G	DADO M6	NUT M6	2	

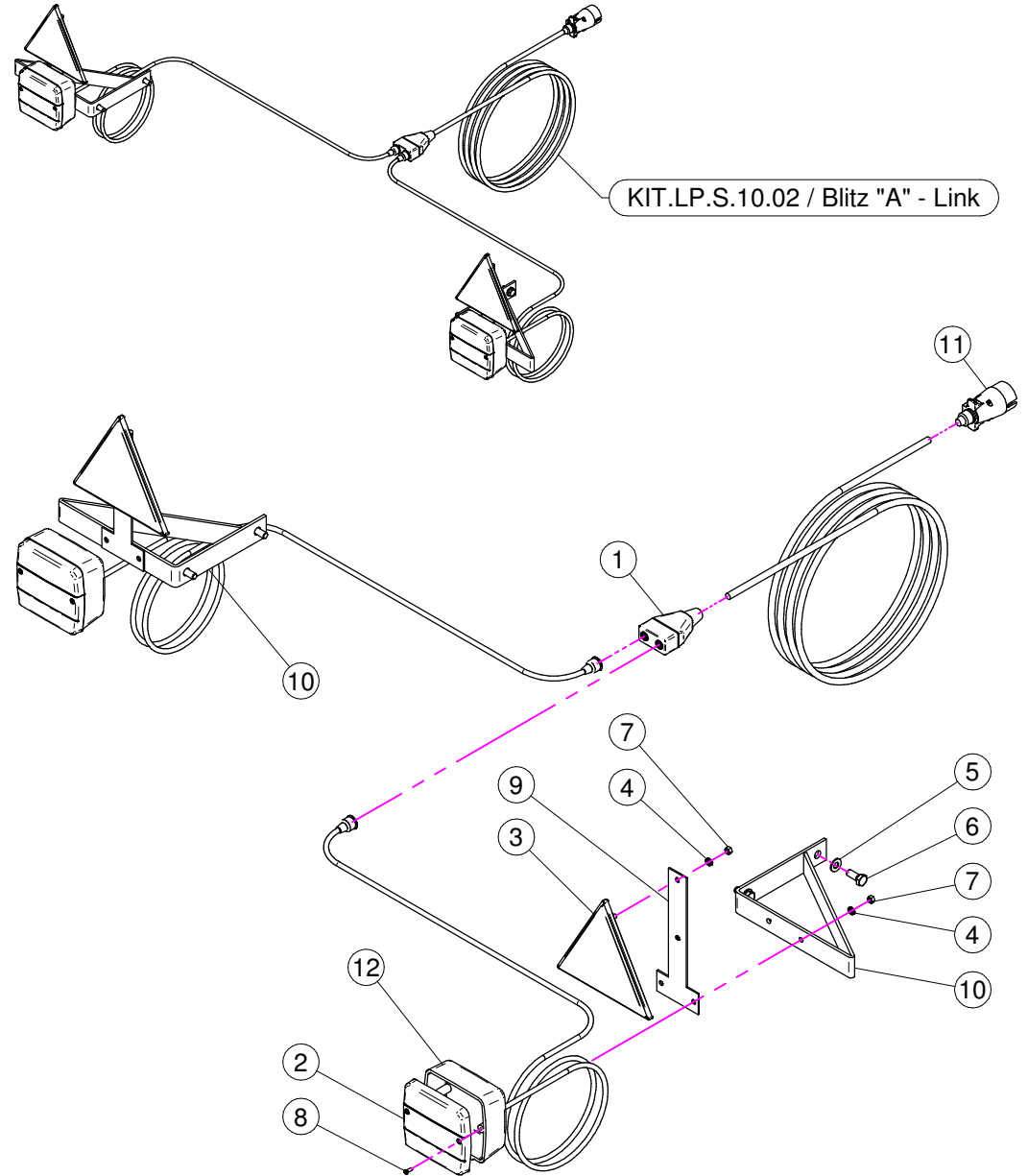
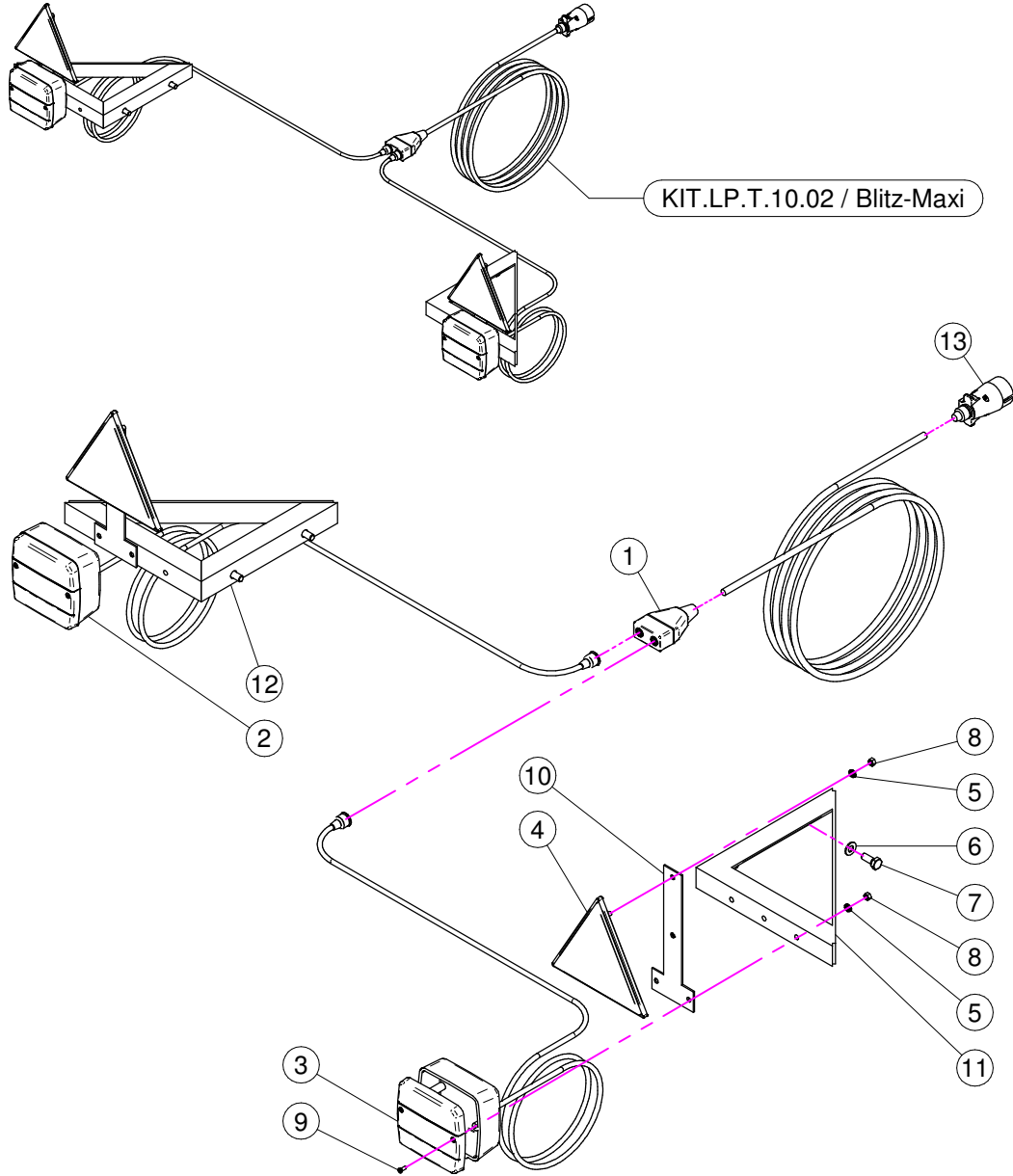

KIT.LP.T.10.02 (BLITZ-MAXI)

N°	Doc. Number	Titolo	Title	Q.tà	Note
1	X24.121.007	SCATOLA BLOCCO DIRAMAZIONI	ELECTRIC BOX	1	
2	X24.121.002	CORPO FANALE POSTERIORE 3F	BODY REAR LIGHT 3L	1	
3	X24.121.004	CATADIOTTRO FANALE POSTERIORE	REAR LIGHT REFLECTOR	2	
4	X24.121.001	CATADIOTTRO TRIANGOLARE	TRIANGULAR REFLECTOR	2	
5	XRD.005.000	RONDELLA DENTELLATA D.5	TAB WASHER D.5	8	
6	XRP.008.000	RONDELLA PIANA D.8	WASHER D.8	4	
7	XTE.008.020T	VITE TE 8x20	SCREW TE 8x20	4	
8	XD0.05.5587G	DADO M5 PG 5587	M5 PG 5587 NUT	8	
9	XTA.03,5.09,5I	VITE AUTOFILETTANTE D.3,5 x 9,5	SELF THREADING D.3,5 x 9,5	4	
10	X40.341.000	STAFFA	BRACKET	2	
11	X40.340.200	STAFFA DX	BRACKET DX	1	
12	X40.340.100	STAFFA SX	BRACKET SX	1	
13	X24.121.006	SPINA	PLUG	1	

KIT.LP.S.10.02 (BLITZ "A" - LINK)

N°	Doc. Number	Titolo	Title	Q.tà	Note
1	X24.121.007	SCATOLA BLOCCO DIRAMAZIONI	ELECTRIC BOX	1	
2	X24.121.004	CATADIOTTRO FANALE POSTERIORE	REAR LIGHT REFLECTOR	2	
3	X24.121.001	CATADIOTTRO TRIANGOLARE	TRIANGULAR REFLECTOR	2	
4	XRD.005.000	RONDELLA DENTELLATA D.5	TAB WASHER D.5	8	
5	XRP.008.000	RONDELLA PIANA D.8	WASHER D.8	4	
6	XTE.008.020T	VITE TE 8x20	SCREW TE 8x20	4	
7	XD0.05.5587G	DADO M5 PG 5587	M5 PG 5587 NUT	8	
8	XTA.03,5.09,5I	VITE AUTOFILETTANTE D.3,5 x 9,5	SELF THREADING D.3,5 x 9,5	4	
9	X40.341.000	STAFFA	BRACKET	2	
10	X40.340.000	STAFFA	BRACKET	2	
11	X24.121.006	SPINA	PLUG	1	
12	X24.121.002	CORPO FANALE POSTERIORE 3F	BODY REAR LIGHT 3L	1	

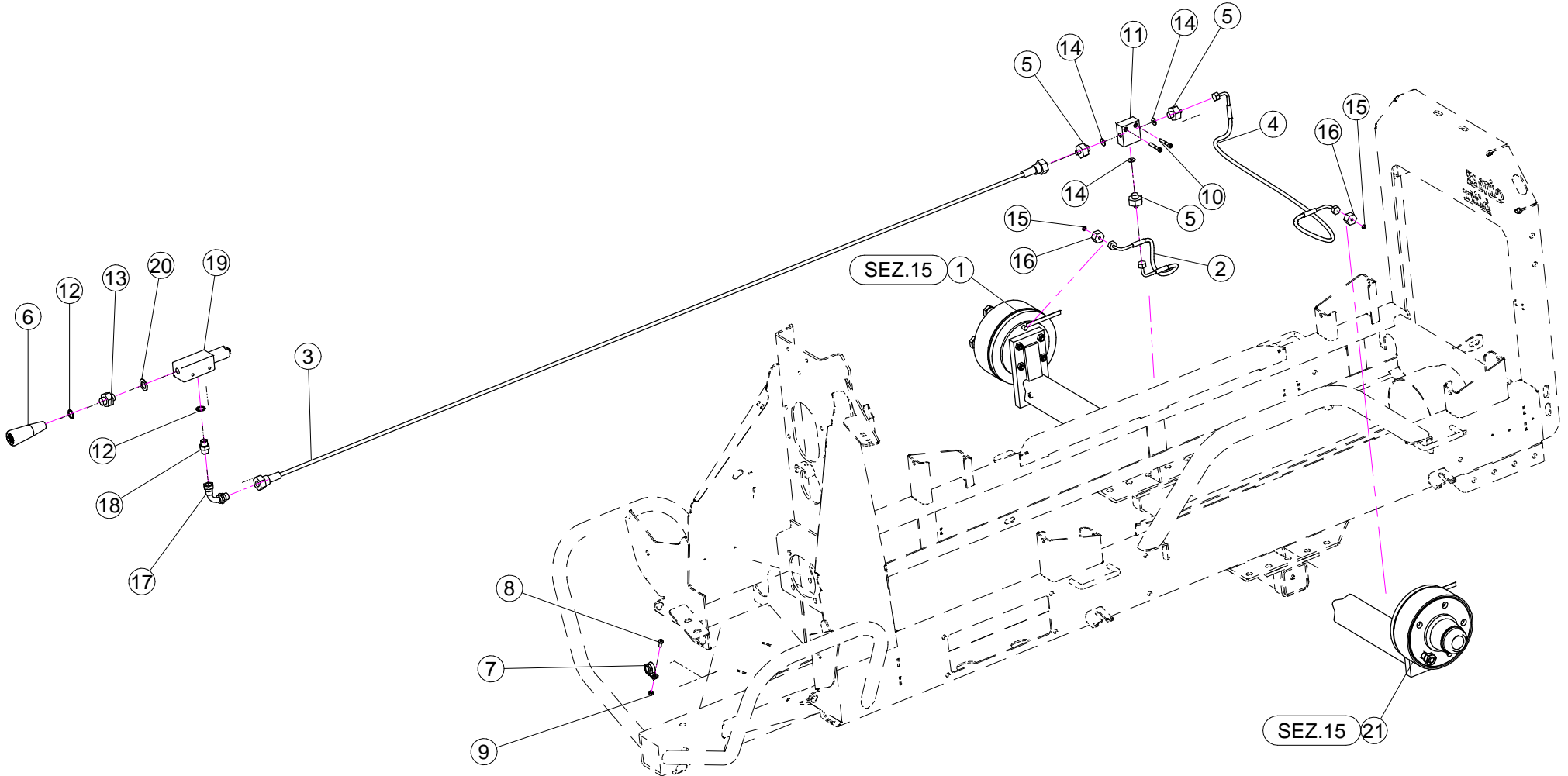

N°	Doc. Number	Titolo	Title	Q.tà
1	X04.683.500	SEMIASSE A 5 COLONNETTE CON FRENO MONTATO SU BLITZ	WHEEL HUB	1
2	X21.341.060	TUBO OLIO 1/4" L=600 CON RACCORDI	OIL HOSE 1/4" L=600 WITH FITTINGS	1
3	X21.341.350	TUBO OLIO 1/4" L=3500 CON RACCORDI	OIL HOSE 1/4" L=3500 WITH FITTINGS	1
4	X21.341.100	TUBO OLIO 1/4" L=1000 CON RACCORDI	OIL HOSE 1/4" L=1000 WITH FITTINGS	1
5	X21.342.000	NIPPLO DOPPIO 1/4" 1/4"	DOUBLE NIPLES 1/4" 1/4"	3
6	X21.343.000	INNESTO FASTER	CLUTCH	1
7	XFG.018.000	FASCETTA GOMMATA PER TUBI D.18	STICKER	1
8	XTCC.06.16	VITE TESTA A CROCE M6x16	CROSS SLOTTED SCREW M6x16	1
9	XDOT.06.5587	DADO OTTONE M6	M6 BRASS NUT 5587	1
10	XTCE.006 .040	VITE BRUGOLA TCE M6x40	BOLT TCE M6x40	2
11	X21.348.000	DISTRIBUTORE OLIO PER FRENO	BRAKE OIL DISTRIBUTOR	1
12	X21.344.000	RONDELLA RAME D.18x1,5	COPPER WASHER D.18x1,5	2
13	X21.345.000	NIPPLO RIDOTTO 3/8 - m18	NIPLES 3/8 - M18	1
14	X21.349.000	RONDELLA RAME D.1/4	COPPER WASHER D.1/4	3
15	X21.346.000	RONDELLA RAME D.10x1,5	COPPER WASHER D.10x1,5	2
16	X21.347.000	RACCORDO RAD 1803	RAD 1803 FITTING	2
17	X21.381.000	CURVA PER OLIO 3/8 M - 3/8 F	OIL BEND 3/8 M - 3/8 F	1
18	X21.107.000	NIPPLO 3/8M - 3/8M	NIPLES 3/8M - 3/8M	1
19	X21.382.000	VALVOLA MASSIMA PRESSIONE OLIO 60 bar	MAXIMUM PRESSURE OIL VALVE 60 bar	1
20	X21.362.000	RONDELLA RAME D.30x18x1,5	COPPER WASHER D.30x18x1,5	1
21	X04.683.700	SEMIASSE A 5 COLONNETTE CON FRENO	WHEEL HUB	1

SEMIASSE SINISTRO

X04.683.700

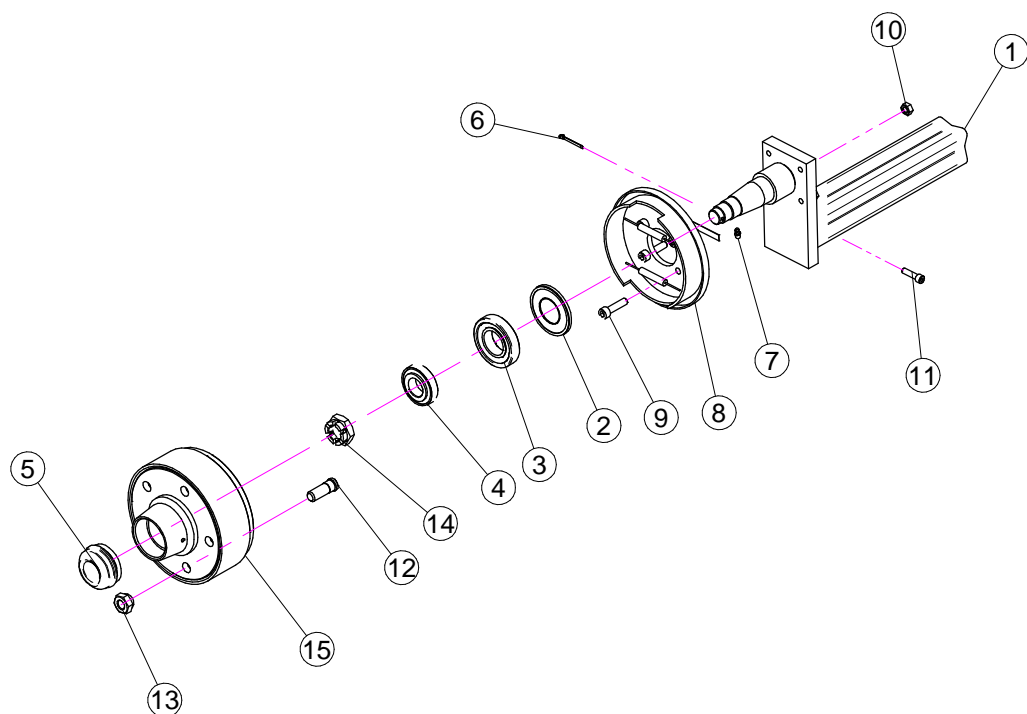
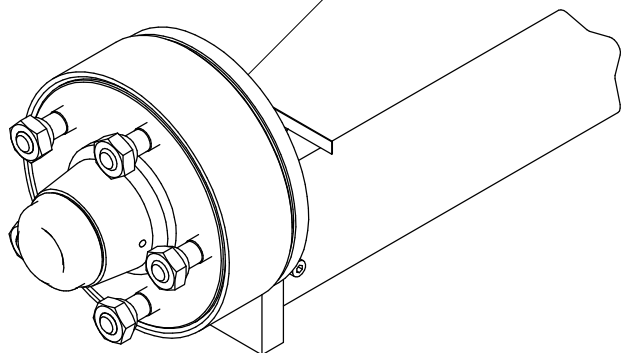

SEMIASSE DESTRO

X04.683.500

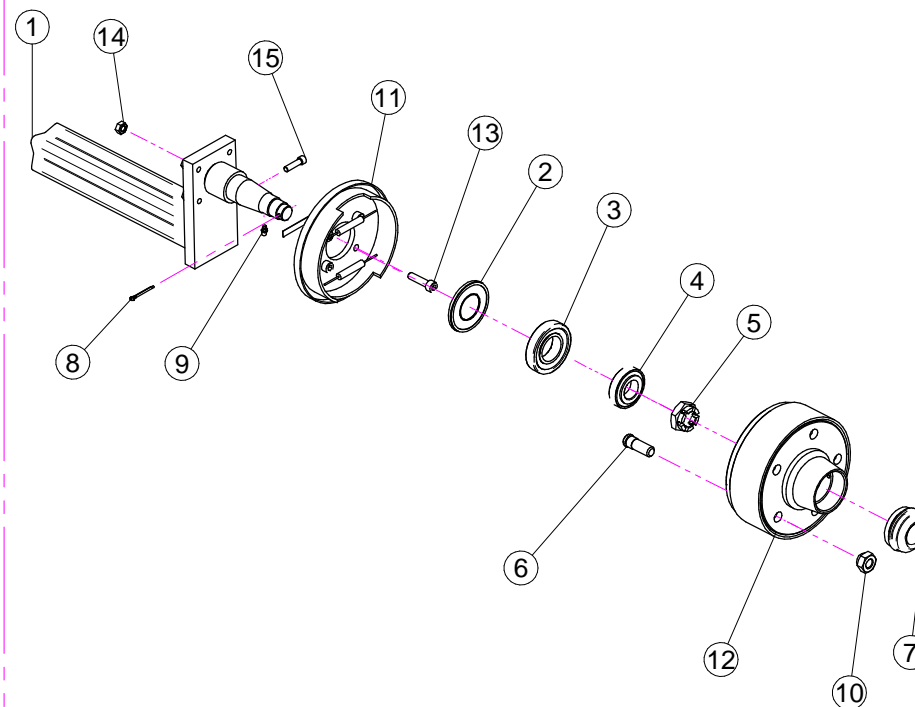
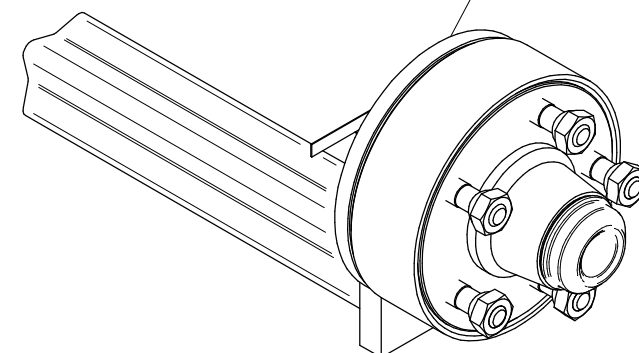

X04.683.700

X04.683.500

N°	Doc. Number	Titolo	Title	Q.tà
1	X04.683.501	SEMIASSE A 5 COLONNETTE ALLUNGATO PER FRENO	AXLE SHAFT	1
2	X20.257.000	PARA - POLVERE D. 40x80 IN GOMMA	DUST SHIELDER	1
3	XK0.030.208	CUSCINETTO A UNA CORONA DI RULLI CONICI	BEARING	1
4	XK0.030.206	CUSCINETTO A UNA CORONA DI RULLI CONICI 30206	BEARING	1
5	X04.062.001	COPERCHIETTO DI CHIUSURA	COVER	1
6	X20.259.000	COPIGLIA D.4 L=45 PER MOZZI	SPLIT PIN	1
7	XID.006.001	INGRASSATORE DIRITTO M6	GREASER	1
8	X40.388.000	FRENO SX COMPLETO	LEFT BRAKE	1
9	XTCE.010.040	VITE TESTA CIL. CON ESAGONO INCASSATO	HEXAGON SOCKET HEAD SCREW M10 x 40	1
10	XD0.10.5588G	DADO M 10 6S PG	M10 6S BIG LEAD NUT 5588	1
11	XTCE.008.030	VITE BRUGOLA TCE M8x30	BOLT TCE M8x30	1
12	X04.681.000	COLONNETTA PER SEMIASSE M16x1,5	STUD M16x1,5	1
13	X04.682.000	DADO PER COLONNETTA M 16x1.5	SPECIAL NUT	1
14	XDI.027.5594F	DADO ESAGONALE A 6 INTAGLI	SIX CASTLE NUT M27	1
15	X04.200.100	TAMBURO PER FRENO	BRAKE DRUM	1

N°	Doc. Number	Titolo	Title	Q.tà
1	X04.683.501	SEMIASSE A 5 COLONNETTE ALLUNGATO PER FRENO	AXLE SHAFT	1
2	X20.257.000	PARA - POLVERE D. 40x80 IN GOMMA	DUST SHIELDER	1
3	XK0.030.208	CUSCINETTO A UNA CORONA DI RULLI CONICI	BEARING	1
4	XK0.030.206	CUSCINETTO A UNA CORONA DI RULLI CONICI 30206	BEARING	1
5	XDI.027.5594F	DADO ESAGONALE A 6 INTAGLI	SIX CASTLE NUT M27	1
6	X04.681.000	COLONNETTA PER SEMIASSE M16x1,5	STUD M16x1,5	5
7	X04.062.001	COPERCHIETTO DI CHIUSURA	COVER	1
8	X20.259.000	COPIGLIA D.4 L=45 PER MOZZI	SPLIT PIN	1
9	XID.006.001	INGRASSATORE DIRITTO M6	GREASER	1
10	X04.682.000	DADO PER COLONNETTA M 16x1.5	SPECIAL NUT	5
11	X40.389.000	FRENO DX COMPLETO	RIGHT BRAKE	1
12	X04.200.100	TAMBURO PER FRENO	BRAKE DRUM	1
13	XTCE.010.040	VITE TESTA CIL. CON ESAGONO INCASSATO	HEXAGON SOCKET HEAD SCREW M10 x 40	4
14	XD0.10.5588G	DADO M 10 6S PG	M10 6S BIG LEAD NUT 5588	4
15	XTCE.008.030	VITE BRUGOLA TCE M8x30	BOLT TCE M8x30	1

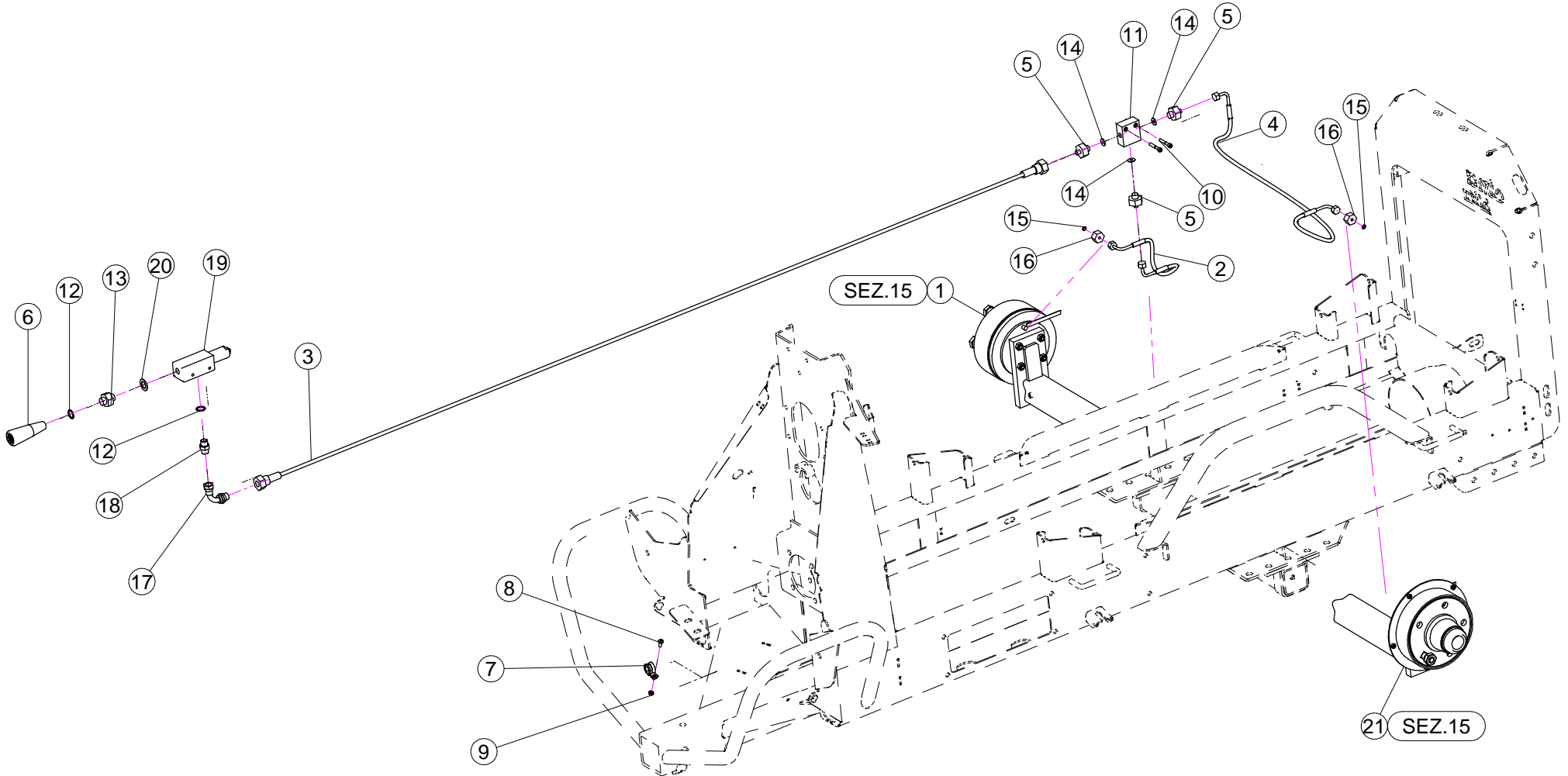

N°	Doc. Number	Titolo	Title	Q.tà
1	X04.683.500	SEMIASSE A 5 COLONNETTE CON FRENO MONTATO SU BLITZ	WHEEL HUB	1
2	X21.341.060	TUBO OLIO 1/4" L=600 CON RACCORDI	OIL HOSE 1/4" L=600 WITH FITTINGS	1
3	X21.341.350	TUBO OLIO 1/4" L=3500 CON RACCORDI	OIL HOSE 1/4" L=3500 WITH FITTINGS	1
4	X21.341.100	TUBO OLIO 1/4" L=1000 CON RACCORDI	OIL HOSE 1/4" L=1000 WITH FITTINGS	1
5	X21.342.000	NIPPLO DOPPIO 1/4" 1/4"	DOUBLE NIPLES 1/4" 1/4"	3
6	X21.343.000	INNESTO FASTER	CLUTCH	1
7	XFG.018.000	FASCETTA GOMMATA PER TUBI D.18	STICKER	1
8	XTCC.06.16	VITE TESTA A CROCE M6x16	CROSS SLOTTED SCREW M6x16	1
9	XDOT.06.5587	DADO OTTONE M6	M6 BRASS NUT 5587	1
10	XTCE.006 .040	VITE BRUGOLA TCE M6x40	BOLT TCE M6x40	2
11	X21.348.000	DISTRIBUTORE OLIO PER FRENO	BRAKE OIL DISTRIBUTOR	1
12	X21.344.000	RONDELLA RAME D.18x1,5	COPPER WASHER D.18x1,5	2
13	X21.345.000	NIPPLO RIDOTTO 3/8 - m18	NIPLES 3/8 - M18	1
14	X21.349.000	RONDELLA RAME D.1/4	COPPER WASHER D.1/4	3
15	X21.346.000	RONDELLA RAME D.10x1,5	COPPER WASHER D.10x1,5	2
16	X21.347.000	RACCORDO RAD 1803	RAD 1803 FITTING	2
17	X21.381.000	CURVA PER OLIO 3/8 M - 3/8 F	OIL BEND 3/8 M - 3/8 F	1
18	X21.107.000	NIPPLO 3/8M - 3/8M	NIPLES 3/8M - 3/8M	1
19	X21.382.000	VALVOLA MASSIMA PRESSIONE OLIO 60 bar	MAXIMUM PRESSURE OIL VALVE 60 bar	1
20	X21.362.000	RONDELLA RAME D.30x18x1,5	COPPER WASHER D.30x18x1,5	1
21	X04.683.400	SEMIASSE A 5 COLONNETTE CON FRENO	WHEEL HUB	1

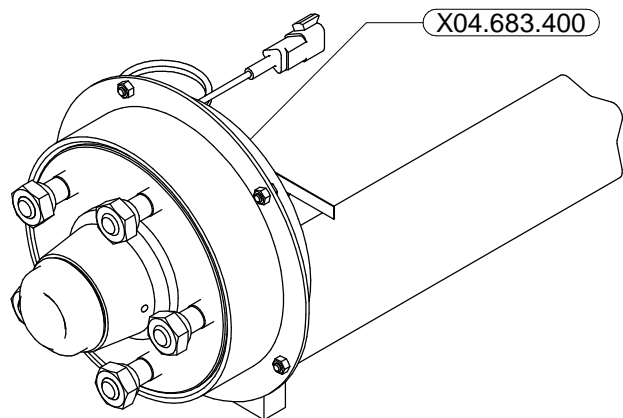

SEMIASSE SINISTRO

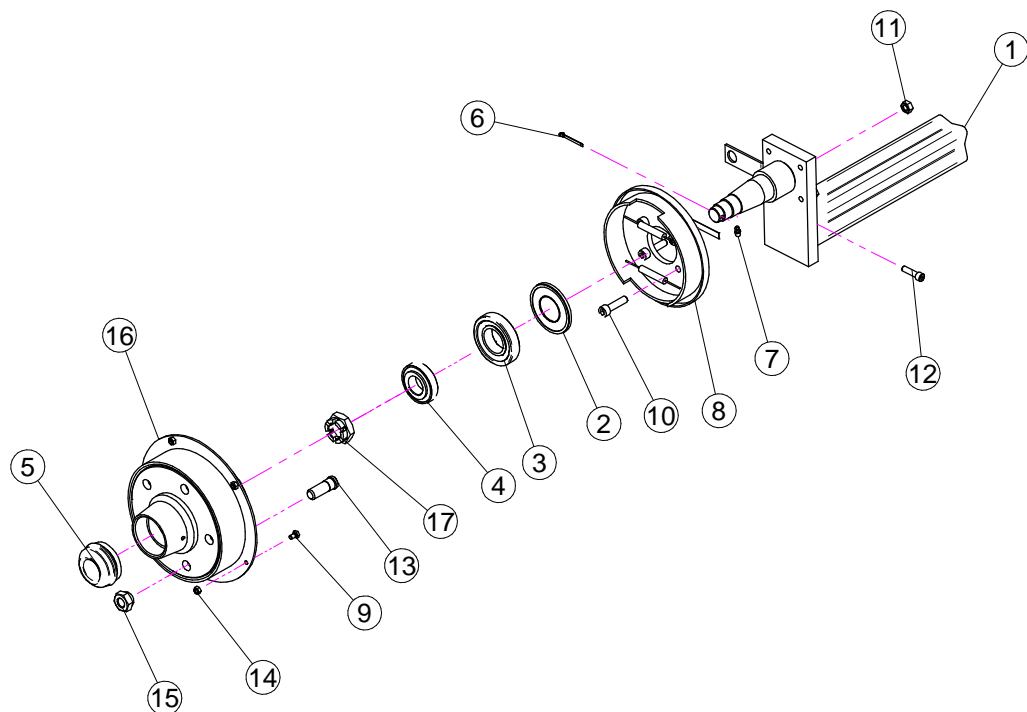

SEMIASSE DESTRO

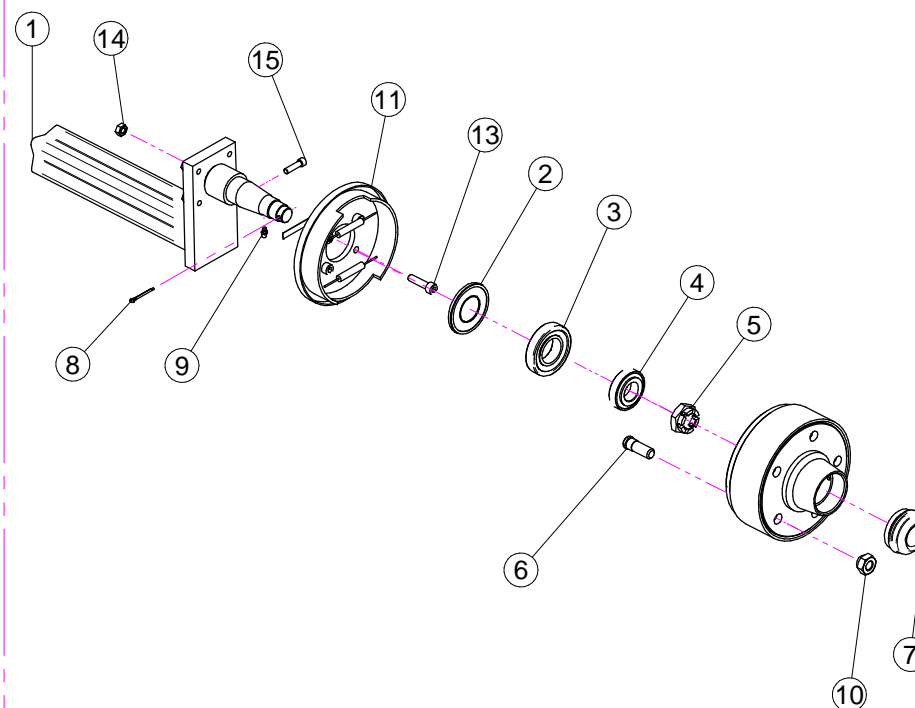
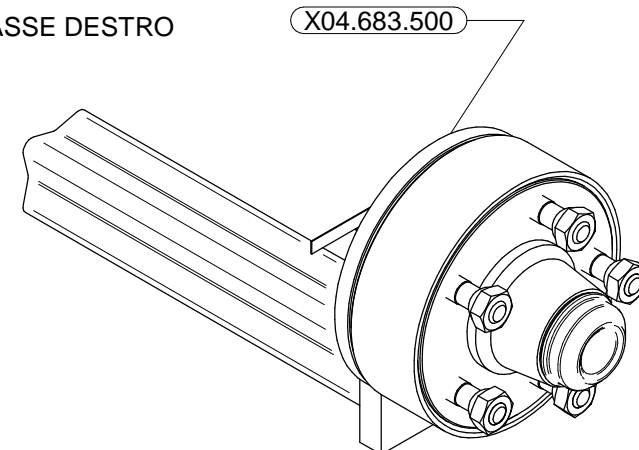

X04.683.400

X04.683.500

N°	Doc. Number	Titolo	Title	Q.tà
1	X04.683.401	SEMIASSE A 5 COLONNETTE ALLUNGATO PER FRENO ED EPA	AXLE SHAFT	1
2	X20.257.000	PARA - POLVERE D. 40x80 IN GOMMA	DUST SHIELDER	1
3	XK0.030.208	CUSCINETTO A UNA CORONA DI RULLI CONICI	BEARING	1
4	XK0.030.206	CUSCINETTO A UNA CORONA DI RULLI CONICI 30206	BEARING	1
5	X04.062.001	COPERCHIETTO DI CHIUSURA	COVER	1
6	X20.259.000	COPIGLIA D.4 L=45 PER MOZZI	SPLIT PIN	1
7	XID.006.001	INGRASSATORE DIRITTO M6	GREASER	1
8	X40.388.000	FRENO SX COMPLETO	LEFT BRAKE	1
9	XTE.006.010T	VITE TE M6x10	SCREW TE M6x10	1
10	XTCE.010.040	VITE TESTA CIL. CON ESAGONO INCASSATO	HEXAGON SOCKET HEAD SCREW M10 x 40	1
11	XD0.10.5588G	DADO M 10 6S PG	M10 6S BIG LEAD NUT 5588	1
12	XTCE.008.030	VITE BRUGOLA TCE M8x30	BOLT TCE M8x30	1
13	X04.681.000	COLONNETTA PER SEMIASSE M16x1,5	STUD M16x1,5	1
14	XD0.06.5588G	DADO M6	NUT M6	1
15	X04.682.000	DADO PER COLONNETTA M 16x1.5	SPECIAL NUT	1
16	X04.200.000	TAMBURO PER FRENO E EPA	BRAKE DRUM	1
17	XDI.027.5594F	DADO ESAGONALE A 6 INTAGLI	SIX CASTLE NUT M27	1

N°	Doc. Number	Titolo	Title	Q.tà
1	X04.683.501	SEMIASSE A 5 COLONNETTE ALLUNGATO PER FRENO	AXLE SHAFT	1
2	X20.257.000	PARA - POLVERE D. 40x80 IN GOMMA	DUST SHIELDER	1
3	XK0.030.208	CUSCINETTO A UNA CORONA DI RULLI CONICI	BEARING	1
4	XK0.030.206	CUSCINETTO A UNA CORONA DI RULLI CONICI 30206	BEARING	1
5	XDI.027.5594F	DADO ESAGONALE A 6 INTAGLI	SIX CASTLE NUT M27	1
6	X04.681.000	COLONNETTA PER SEMIASSE M16x1,5	STUD M16x1,5	5
7	X04.062.001	COPERCHIETTO DI CHIUSURA	COVER	1
8	X20.259.000	COPIGLIA D.4 L=45 PER MOZZI	SPLIT PIN	1
9	XID.006.001	INGRASSATORE DIRITTO M6	GREASER	1
10	X04.682.000	DADO PER COLONNETTA M 16x1.5	SPECIAL NUT	5
11	X40.389.000	FRENO DX COMPLETO	RIGHT BRAKE	1
12*	X04.200.100	TAMBURO PER FRENO	BRAKE DRUM	1
13	XTCE.010.040	VITE TESTA CIL. CON ESAGONO INCASSATO	HEXAGON SOCKET HEAD SCREW M10 x 40	4
14	XD0.10.5588G	DADO M 10 6S PG	M10 6S BIG LEAD NUT 5588	4
15	XTCE.008.030	VITE BRUGOLA TCE M8x30	BOLT TCE M8x30	1